

Oracle® Communications Session Border Controller

Accounting Guide



Release S-Cz8.3.0
F20270-04
March 2021

The Oracle logo, consisting of a solid red square with the word "ORACLE" in white, uppercase, sans-serif font centered within it.

ORACLE®

F20270-04

Copyright © 2018, 2021, Oracle and/or its affiliates.

This software and related documentation are provided under a license agreement containing restrictions on use and disclosure and are protected by intellectual property laws. Except as expressly permitted in your license agreement or allowed by law, you may not use, copy, reproduce, translate, broadcast, modify, license, transmit, distribute, exhibit, perform, publish, or display any part, in any form, or by any means. Reverse engineering, disassembly, or decompilation of this software, unless required by law for interoperability, is prohibited.

The information contained herein is subject to change without notice and is not warranted to be error-free. If you find any errors, please report them to us in writing.

If this is software or related documentation that is delivered to the U.S. Government or anyone licensing it on behalf of the U.S. Government, then the following notice is applicable:

U.S. GOVERNMENT END USERS: Oracle programs (including any operating system, integrated software, any programs embedded, installed or activated on delivered hardware, and modifications of such programs) and Oracle computer documentation or other Oracle data delivered to or accessed by U.S. Government end users are "commercial computer software" or "commercial computer software documentation" pursuant to the applicable Federal Acquisition Regulation and agency-specific supplemental regulations. As such, the use, reproduction, duplication, release, display, disclosure, modification, preparation of derivative works, and/or adaptation of i) Oracle programs (including any operating system, integrated software, any programs embedded, installed or activated on delivered hardware, and modifications of such programs), ii) Oracle computer documentation and/or iii) other Oracle data, is subject to the rights and limitations specified in the license contained in the applicable contract. The terms governing the U.S. Government's use of Oracle cloud services are defined by the applicable contract for such services. No other rights are granted to the U.S. Government.

This software or hardware is developed for general use in a variety of information management applications. It is not developed or intended for use in any inherently dangerous applications, including applications that may create a risk of personal injury. If you use this software or hardware in dangerous applications, then you shall be responsible to take all appropriate fail-safe, backup, redundancy, and other measures to ensure its safe use. Oracle Corporation and its affiliates disclaim any liability for any damages caused by use of this software or hardware in dangerous applications.

Oracle and Java are registered trademarks of Oracle and/or its affiliates. Other names may be trademarks of their respective owners.

Intel and Intel Inside are trademarks or registered trademarks of Intel Corporation. All SPARC trademarks are used under license and are trademarks or registered trademarks of SPARC International, Inc. AMD, Epyc, and the AMD logo are trademarks or registered trademarks of Advanced Micro Devices. UNIX is a registered trademark of The Open Group.

This software or hardware and documentation may provide access to or information about content, products, and services from third parties. Oracle Corporation and its affiliates are not responsible for and expressly disclaim all warranties of any kind with respect to third-party content, products, and services unless otherwise set forth in an applicable agreement between you and Oracle. Oracle Corporation and its affiliates will not be responsible for any loss, costs, or damages incurred due to your access to or use of third-party content, products, or services, except as set forth in an applicable agreement between you and Oracle.

Contents

About this Guide

My Oracle Support xii

Revision History

1 Using RADIUS with the OCSBC

RTP Traffic Reporting per Call	1-1
Introduction	1-2
Licensing	1-3
Overview	1-3
Standard RADIUS Attributes	1-3
Standard RADIUS Attributes Dictionary	1-4
RADIUS Accounting Termination Causes	1-5
VSA	1-6
Oracle RADIUS VSAs	1-6
R-Factor and MOS	1-7
Media Flow Attributes	1-8
Acme-Extended-Attributes Explanation	1-29
IPv6 Support	1-30
Oracle VSA Values	1-31
Authentication VSAs	1-34
Cisco Systems RADIUS Decodes	1-34
Mappings and Disconnect Cause Values	1-35
SIP H.323 and Q.850 Mappings	1-35
SIP Status to H.323 Disconnect Reason Mapping	1-36
SIP Status to H.323 RAS Error Mapping	1-36
SIP Status to H.323 Release Complete Reason Error Mapping	1-36
Q.850 Cause to H.323 Release Complete Reason Mapping	1-37
SIP-SIP Calls	1-37
SIP-H.323 Calls with Interworking	1-38
SIP Events and Errors	1-38

H.323 Events and Errors	1-39
H.225 RAS Errors	1-40
SIP Call Tear Down Due to Media Guard Timer Expiration	1-40
CDR Output	1-40
Explanation	1-41

2 Configuring Accounting

Overview	2-1
Accounting for SIP and H.323	2-1
Call Detail Records	2-1
RAS Overview	2-2
RADIUS Accounting Client	2-2
Session Accounting	2-3
Interim RADIUS Records for Recursive Attempts	2-4
RADIUS Messages	2-4
Session Termination	2-5
ACLI Instructions and Examples	2-5
Accessing the Accounting and Accounting Servers Configuration	2-5
Setting Up the Account Configuration	2-6
Setting Up Accounting Servers	2-8
SIP CDR Stop Time	2-9
ACLI Instructions and Examples	2-9
Set Acct-session-time attribute to milliseconds	2-10
Configure acct-session-time for millisecond granularity	2-10
Per Realm Accounting Control	2-10
ACLI Instructions	2-11
Configurable Intermediate Period	2-11
Media Stop Time VSA in CDRs	2-12
Media Stop Time VSAs	2-12
Media Stop Time Calculation	2-12
HA Caveat	2-13
RADIUS CDR Content Control	2-13
ACLI Instructions and Examples	2-13
Accessing the Accounting Configuration	2-13
Preventing Duplicate RADIUS Attributes	2-14
RADIUS Attribute Selection	2-14
Custom RADIUS CDR VSAs for SIP	2-15
About User-Defined VSAs for SIP Calls	2-15
HMR Adaptations	2-15
HMR String Variable	2-16

ACLI Instructions and Examples User-Defined VSAs	2-16
ACLI Instructions and Examples String Variable	2-19
Trunk-Group VSA Generation	2-20
ACLI Instructions and Examples	2-20
RADIUS Account Server Prioritization	2-20
How You Might User Server Prioritization	2-21
ACLI Instructions and Examples	2-21
Accounting Configuration Example	2-22
Local CDR Storage and FTP Push	2-23
Local CDR File Format	2-24
Local CDR File Format Consistency	2-24
Generate Local CDR Layout Files	2-24
Requirements	2-26
Local CDR File Naming Convention	2-26
Call Detail Record Sequence Number in Filename	2-27
CDR Sequence Number in Filename Configuration	2-27
Temp-remote-file creation for CDR files during transfer Configuration	2-27
Local CDR File Storage Directories	2-28
Local CDR File Size and Rotation	2-28
More About File Rotation Time	2-28
RADIUS CDR Redundancy	2-28
Caveats for H.323	2-29
FTP Push	2-29
Deprecated ACLI Configuration	2-29
Multiple Push Receivers	2-29
Push Receivers	2-30
Secure FTP Push Configuration	2-30
ACLI Instructions and Examples	2-30
Accessing the Accounting Configuration	2-31
Enabling Local CDR Storage	2-31
Configuring a Push Receiver Fallback Method	2-32
Setting the CSV File Format	2-32
Enabling FTP Push	2-33
Creating a Public Key Profile	2-34
SSH Operations	2-34
ACLI Instructions and Examples	2-35
Configure SSH Properties	2-35
Import an SSH host Key	2-36
Create the Public Key Record	2-38
Generate an SSH key pair	2-39
Copy the RSA Public Key to the SFTP Server	2-40

View a Public key on the OCSBC	2-40
Temporary File Naming for an Open CDR File	2-43
Operational Details	2-44
HA Considerations	2-44
Caveats	2-46
Temporary Local CDR File Renaming Configuration	2-46
Enhanced Stop CDR Reporting for Exceeded Ingress Session Constraints	2-47

3 RADIUS Accounting Management

Overview	3-1
Alarm Generation and Monitoring	3-1
RADIUS Alarms	3-1
Status and Statistics Monitoring	3-2
ACLI Show RADIUS Display	3-2
Monitoring CDR Push Receivers	3-5
SNMP Support	3-5
CDR File Transfer Failure Alarm	3-5

4 Storage Expansion Module

Storage Expansion Module Use With Local CDRs FTP Push	4-1
Local CDR Storage Directory	4-1
FTP Push Backup	4-1
Local CDR File Compression	4-1
ACLI Configuration and Examples	4-1
Identify Volumes	4-2
Configure File Path	4-2
Storage Expansion Module Management	4-2
Storage Expansion Module Monitoring	4-3
Low Disk Space Warning	4-3
Low Disk Space Threshold Alarm	4-3
Low Disk Space Threshold SNMP Trap	4-3
ACLI Configuration and Examples	4-3
Local CDR File Delete Warning	4-4
Local CDR File Delete Alarm	4-5
Local CDR File Delete SNMP Trap	4-5
Querying Storage Space	4-5
ACLI	4-5
Unmounting The Storage Expansion Module	4-5
ACLI Instructions and Examples	4-6

SNMP MIB	4-6
HDR	4-7

5 Diameter Rf Accounting

Diameter Accounting	5-1
Diameter Accounting Messages	5-1
Resending ACRs	5-1
Postponement Feature	5-1
Call Flow Examples	5-1
ACR AVP Descriptions	5-3
Session-Id AVP (263)	5-4
Origin-Host AVP (264)	5-4
Origin-Realm AVP (296)	5-4
Destination-Realm AVP (283)	5-4
Destination-Host AVP (293)	5-4
Accounting-Record-Type AVP (480)	5-4
Accounting-Record-Number AVP (485)	5-4
Acct-Application-Id AVP (259)	5-6
User-Name AVP (1)	5-6
Event-Timestamp AVP (55)	5-6
Event-Type AVP (823)	5-6
Role-of-Node AVP (829)	5-7
User-Session-Id AVP (830)	5-7
Calling-Party-Address AVP (831)	5-7
Called-Party-Address AVP (832)	5-7
Time-Stamps AVP (833)	5-7
Inter-Operator-Identifier AVP (838)	5-7
SDP-Session-Description AVP (842)	5-8
Session-Media-Component AVP (845)	5-8
Cause AVP (860)	5-8
Values for Cause Code AVP (861)	5-8
ACR Event Records	5-9
ACR Event Message Construction	5-9
Event-Type AVP	5-10
Expires Value	5-10
Event ACRs Generated for Unsuccessful Session Attempts	5-10
Event ACRs Generated for Receipt of SIP Messages	5-13
Event Local CSV File	5-15
Diameter Heartbeat for Rf	5-15
Configuring Diameter-based Accounting	5-16

Configure the Global Diameter-based Accounting (Rf) Features	5-16
Configure Accounting Servers	5-18
Additional Rf Features Alarms and Traps	5-20
Service-Context-ID Format	5-20
Acme Excluded Attribute Range	5-20
Configure Account	5-21
SNMP Trap Behavior	5-21
Alarms	5-23
SNMP MIBs and Traps	5-23
ApDiamResultCode Textual Convention	5-23
apDiameterSrvrErrorResultTrap	5-24
apDiameterSrvrSuccessResultTrap	5-25
apDiamACCTResultObjectsGroup Object Group	5-25
apDiamACCTResultNotificationsGroup Notification Group	5-25
SNMP Varbind Definitions	5-25
Diameter Rf Charging Buffering and Storage	5-26
About Buffering	5-26
About Storage	5-26
Monitoring Storage Space	5-26
ACLI Instructions and Examples	5-26
SNMP	5-27
DIAMETER Rf Charging Failure & Recovery Detection	5-27
Associated Traps	5-28

A RADIUS Dictionary Reference

B Comma-Delimited Entries for Local Files

C Comma-Delimited Local Files for Diameter Rf Accounting

D Oracle Rf Interface Support

Diameter AVP Notation	D-1
Table Explanation	D-1
Root ACR Message Format	D-1
Service Information AVP	D-2
Subscription ID AVP	D-2
IMS Information AVP	D-2
Event-Type AVP	D-3

Time Stamps AVP	D-4
Inter-Operator-Identifier AVP	D-4
SDP-Media-Component AVP	D-4
Early-Media-Description AVP	D-4
SDP-Timestamps AVP	D-5
Message-Body AVP	D-5
Acme-Packet-Specific-Extension-Rf AVP	D-5
AVP Definitions	D-9
System Alarming Based on Received Result-Code (268) AVP	D-12
Interim ACR Message Creation Interval per Acct-Interim-Interval AVP	D-13

About this Guide

Overview

The Oracle Communications Session Border Controller Accounting Guide describes:

- The Oracle Communications Session Border Controller's accounting-based options on Remote Authentication Dial-in User Service (RADIUS)
- How to configure RADIUS accounting support, and the features related to it
- Local CDR storage and FTP file push
- Use and maintenance of the Storage Expansion Module
- Diameter-based Rf Accounting

It includes the Acme Packet accounting Vendor-Specific Attributes (VSAs), and the Cisco Systems, Inc.™ VSAs supported by the Oracle Communications Session Border Controller. This reference guide indicates the Cisco Systems' VSAs supported by Oracle's products.

This guide also includes RADIUS-related statistics and alarm information and associated Acme Packet Command Line Interface (ACLI) configuration element examples. Appendix A of this guide contains a selection of examples of RADIUS logs for purposes of reference.

Documentation Set

The following table describes the documentation set for this release.

Document Name	Document Description
Acme Packet 3900 Hardware Installation Guide	Contains information about the components and installation of the Acme Packet 3900.
Acme Packet 4600 Hardware Installation Guide	Contains information about the components and installation of the Acme Packet 4600.
Acme Packet 6100 Hardware Installation Guide	Contains information about the components and installation of the Acme Packet 6100.
Acme Packet 6300 Hardware Installation Guide	Contains information about the components and installation of the Acme Packet 6300.
Acme Packet 6350 Hardware Installation Guide	Contains information about the components and installation of the Acme Packet 6350.
Release Notes	Contains information about the current documentation set release, including new features and management changes.
ACLI Configuration Guide	Contains information about the administration and software configuration of the Service Provider Oracle Communications Session Border Controller.

Document Name	Document Description
ACLI Reference Guide	Contains explanations of how to use the ACLI, as an alphabetical listings and descriptions of all ACLI commands and configuration parameters.
Maintenance and Troubleshooting Guide	Contains information about Oracle Communications Session Border Controller logs, performance announcements, system management, inventory management, upgrades, working with configurations, and managing backups and archives.
MIB Reference Guide	Contains information about Management Information Base (MIBs), Oracle Communication's enterprise MIBs, general trap information, including specific details about standard traps and enterprise traps, Simple Network Management Protocol (SNMP) GET query information (including standard and enterprise SNMP GET query names, object identifier names and numbers, and descriptions), examples of scalar and table objects.
Accounting Guide	Contains information about the Oracle Communications Session Border Controller's accounting support, including details about RADIUS and Diameter accounting.
HDR Resource Guide	Contains information about the Oracle Communications Session Border Controller's Historical Data Recording (HDR) feature. This guide includes HDR configuration and system-wide statistical information.
Administrative Security Essentials	Contains information about the Oracle Communications Session Border Controller's support for its Administrative Security license.
SBC Family Security Guide	Contains information about security considerations and best practices from a network and application security perspective for the Oracle Communications Session Border Controller family of products.
Installation and Platform Preparation Guide	Contains information about upgrading system images and any pre-boot system provisioning.
Call Traffic Monitoring Guide	Contains information about traffic monitoring and packet traces as collected on the system. This guide also includes WebGUI configuration used for the SIP Monitor and Trace application.
HMR Resource Guide	Contains information about configuring and using Header Manipulation Rules to manage service traffic.
TSCF SDK Guide	Contains information about the client-side SDK that facilitates the creation of secure tunnels between a client application and the TSCF of the OCSBC.
REST API Guide	Contains information about the supported REST APIs and how to use the REST API interface.

Documentation Accessibility

For information about Oracle's commitment to accessibility, visit the Oracle Accessibility Program website at <http://www.oracle.com/pls/topic/lookup?ctx=acc&id=docacc>.

My Oracle Support

My Oracle Support (<https://support.oracle.com>) is your initial point of contact for all product support and training needs. A representative at Customer Access Support (CAS) can assist you with My Oracle Support registration.

Call the CAS main number at 1-800-223-1711 (toll-free in the US), or call the Oracle Support hotline for your local country from the list at <http://www.oracle.com/us/support/contact/index.html>. When calling, make the selections in the sequence shown below on the Support telephone menu:

1. Select 2 for New Service Request.
2. Select 3 for Hardware, Networking, and Solaris Operating System Support.
3. Select one of the following options:
 - For technical issues such as creating a new Service Request (SR), select 1.
 - For non-technical issues such as registration or assistance with My Oracle Support, select 2.

You are connected to a live agent who can assist you with My Oracle Support registration and opening a support ticket.

My Oracle Support is available 24 hours a day, 7 days a week, 365 days a year.

Emergency Response

In the event of a critical service situation, emergency response is offered by the Customer Access Support (CAS) main number at 1-800-223-1711 (toll-free in the US), or call the Oracle Support hotline for your local country from the list at <http://www.oracle.com/us/support/contact/index.html>. The emergency response provides immediate coverage, automatic escalation, and other features to ensure that the critical situation is resolved as rapidly as possible.

A critical situation is defined as a problem with the installed equipment that severely affects service, traffic, or maintenance capabilities, and requires immediate corrective action. Critical situations affect service and/or system operation resulting in one or several of these situations:

- A total system failure that results in loss of all transaction processing capability
- Significant reduction in system capacity or traffic handling capability
- Loss of the system's ability to perform automatic system reconfiguration
- Inability to restart a processor or the system
- Corruption of system databases that requires service affecting corrective actions
- Loss of access for maintenance or recovery operations
- Loss of the system ability to provide any required critical or major trouble notification

Any other problem severely affecting service, capacity/traffic, billing, and maintenance capabilities may be defined as critical by prior discussion and agreement with Oracle.

Locate Product Documentation on the Oracle Help Center Site

Oracle Communications customer documentation is available on the web at the Oracle Help Center (OHC) site, <http://docs.oracle.com>. You do not have to register to access these documents. Viewing these files requires Adobe Acrobat Reader, which can be downloaded at <http://www.adobe.com>.

1. Access the Oracle Help Center site at <http://docs.oracle.com>.
2. Click **Industries**.
3. Under the Oracle Communications sub-header, click the **Oracle Communications documentation** link.
The Communications Documentation page appears. Most products covered by these documentation sets appear under the headings "Network Session Delivery and Control Infrastructure" or "Platforms."
4. Click on your Product and then Release Number.
A list of the entire documentation set for the selected product and release appears.
5. To download a file to your location, right-click the **PDF** link, select **Save target as** (or similar command based on your browser), and save to a local folder.

Access to Oracle Support

Oracle customers that have purchased support have access to electronic support through My Oracle Support. For information, visit <http://www.oracle.com/pls/topic/lookup?ctx=acc&id=info> or visit <http://www.oracle.com/pls/topic/lookup?ctx=acc&id=trs> if you are hearing impaired.

Revision History

This section provides a revision history for this document.

Date	Description
April 2019	<ul style="list-style-type: none"> Initial Release
May 2019	<ul style="list-style-type: none"> Corrects description of Cisco startup time AVP in CDRs
June 2019	<ul style="list-style-type: none"> Corrects description of acme-disconnect cause and status AVPs
October 2019	<ul style="list-style-type: none"> Updates "Acme-Packet-Specific-Extension-Rf AVP," "Oracle RADIUS VSAs," and "Media Flow Attributes" to include new features available in the S-Cz8.3.0m1 release. Updates "Media Flow Attributes" for accuracy.
July 2020	<ul style="list-style-type: none"> Updates "generate-start" in "Configure the Global Diameter-based Accounting (Rf) Features" and "Setting Up the Account Configuration."
March 2021	<ul style="list-style-type: none"> Updates AVP 39 in Acme-Packet-Specific-Extension-Rf table to correct name of RTP Calling Octets FS2 Updates AVP 83 in Acme-Packet-Specific-Extension-Rf table to correct name of RTCP Called Max Jitter FS2 Updates Acme-Packet-Specific-Extension-Rf AVP Definitions detail table to describe RTP-Calling-Max-Jitter-FS2 is for stream 2 Updates Acme-Packet-Specific-Extension-Rf AVP table to add a "-" as delimiter for all AVP names Corrects Rx AVPs 44 and 45 names, and typos Adds RTCP-Calling-Avg-Latency-FS1 and -FS2 to AVP Definitions table

1

Using RADIUS with the OCSBC

RTP Traffic Reporting per Call

The SBC reports total RTP traffic counts, both received and transmitted for calls through standard accounting interfaces on stop record generation. This traffic is reported in Packets and Octets, sent and received, for flow-sets 1 and 2. The QoS feature set must be enabled to report on RTP traffic, otherwise the values will be reported as 0

These statistics are captured for the following scenarios

- RTP pass-thru sessions
- transcoded/transrated/inband (audio) DTMF-interworked RTP sessions
- RTP sessions where one or both call legs is encrypted (SRTP)

RTP traffic reporting does not capture MSRP B2BUA and MSRP NAT traffic.

The quick way to decipher these 16 statistics are as follows:

- Calling/Called - call-leg the static reports on
- Octets/Packets - counter unit for traffic
- FS1/FS2 - flow set 1 or flow set 2
- blank/transmitted - traffic received (blank) or transmitted by the SBC

Counter Definition	RADIUS/Local CDR (VSA #) output	AVP in Acme-Packet- Specific-Rf-QoS(37)
Number of Octets (8 bits) of RTP traffic, received by the SBC, from the calling party, for flow-set 1	Acme-Calling-Octets-FS1 (28)	RTP-Calling-Octets-FS1 (38)
Number of RTP Packets, sent from the SBC, to the calling UA, for flow-set 1	Acme-Calling-Packets-FS1 (29)	RTP-Calling-Packets-FS1(40)
Number of Octets (8 bits) of RTP traffic, sent from the SBC, to the called UA, for flow-set 1	Acme-Called-Octets-FS1 (44)	RTP-Called-Octets-FS1 (62)
Number of RTP Packets, sent from the SBC, to the called UA, for flow-set 1	Acme-Called-Packets-FS1 (45)	RTP-Called-Packets-FS1 (64)
Number of Octets (8 bits) of RTP traffic, received by the SBC, from the calling party, for flow-set 2	Acme-Calling-Octets-FS2 (102)	RTP-Calling-Octets-FS2 (39)
Number of RTP Packets, sent from the SBC, to the calling UA, for flow-set 2	Acme-Calling-Packets-FS2 (103)	RTP-Calling-Packets-FS2(41)

Counter Definition	RADIUS/Local CDR (VSA #) output	AVP in Acme-Packet-Specific-Rf-QoS(37)
Number of Octets (8 bits) of RTP traffic, sent from the SBC, to the called UA, for flow-set 2	Acme-Called-Octets-FS2 (124)	RTP-Called-Octets-FS2 (63)
Number of RTP Packets, sent from the SBC, to the called UA, for flow-set 2	Acme-Called-Packets-FS2 (125)	RTP-Called-Packets-FS2 (65)
Number of Octets (8 bits) of RTP traffic, transmitted by the SBC, to the calling party, for flow-set 1	Acme-Calling-RTP-Octet-Transmitted-FS1 (240)	RTP-Calling-Octets-Transmitted-FS1 (42)
Number of RTP Packets, transmitted by the SBC, to the calling UA, for flow-set 1	Acme-Calling-RTP-Packets-Transmitted-FS1 (241)	RTP-Calling-Packets-Transmitted-FS1 (44)
Number of Octets (8 bits) of RTP traffic, transmitted by the SBC, to the called UA, for flow-set 1	Acme-Called-RTP-Octet-Transmitted-FS1 (242)	RTP-Called-Octets-Transmitted-FS1 (66)
Number of RTP Packets, transmitted by the SBC, to the called UA, for flow-set 1	Acme-Called-RTP-Packets-Transmitted-FS1 (243)	RTP-Called-Packets-Transmitted-FS1 (68)
Number of Octets (8 bits) of RTP traffic, transmitted by the SBC, to the calling party, for flow-set 2	Acme-Calling-RTP-Octets-Transmitted-FS2 (244)	RTP-Calling-Octets-Transmitted-FS2 (43)
Number of RTP Packets, transmitted by the SBC, to the calling UA, for flow-set 2	Acme-Calling-RTP-Packets-Transmitted-FS2 (245)	RTP-Calling-Packets-Transmitted-FS1 (45)
Number of Octets (8 bits) of RTP traffic, transmitted by the SBC, to the called UA, for flow-set 2	Acme-Called-RTP-Octet-Transmitted-FS2 (246)	RTP-Called-Octets-Transmitted-FS2 (67)
Number of RTP Packets, transmitted by the SBC, to the called UA, for flow-set 2	Acme-Called-RTP-Packets-Transmitted-FS2 (247)	RTP-Called-Packets-Transmitted-FS2 (69)

Introduction

RADIUS is an accounting, authentication, and authorization (AAA) system. In general, RADIUS servers are responsible for receiving user connection requests, authenticating users, and returning all configuration information necessary for the client to deliver service to the user.

You can configure your OCSBC to send call accounting information to one or more RADIUS servers. This information can help you to see usage and QoS metrics, monitor traffic, and even troubleshoot your system. For more information about QoS, refer to the Admission Control and QoS chapter of the ACLI Configuration Guide.

For information about how to configure the OCSBC for RADIUS accounting use, refer to this guide's Configuring Accounting chapter.

Licensing

In order to use RADIUS with your OCSBC, you must have the accounting license installed and activated on your system. For more information about licensing, see the Software Licensing section of the ACLI Configuration Guide's Getting Started chapter. This chapter provides details about Oracle software licensing, including instructions for how to obtain and install licenses.

Overview

For H.323, SIP, and calls being interworked between H.323 and SIP (IWF), you can obtain sets of records that contain information to help you with accounting and that provide a quantitative and qualitative measurement of the call. For H.323 and SIP calls, the OCSBC generates one set of records; for calls requiring IWF, the OCSBC generates two sets of records.

You can use the RADIUS records generated by your OCSBC to assist you with:

- Usage accounting—See the calling and called parties for a call, the protocol used, the realm the call traversed (as well as local and remote IP address and port information), and the codec used
- Traffic monitoring—You can see information about the setup, connect, and disconnect times, as well as the SIP or H.323 disconnect cause
- SLA monitoring—The OCSBC supports RADIUS attributes that provide information about jitter, latency, and loss for H.323, SIP, and calls that require interworking between H.323 and SIP
- Troubleshooting—Obtain information about calls that can help you to identify and address issues with quality and how calls are setup and torn down.

Standard RADIUS Attributes

This section describes the standard RADIUS attributes that the OCSBC supports. These attributes appear along with VSAs (Vendor-Specific Attributes) in the CDRs that the OCSBC generates.

The [Standard RADIUS Attributes Dictionary](#) is a dictionary of the standard RADIUS attributes included in Accounting Request messages sent by the OCSBC to the RADIUS server. The CDR event information determines which messages are generated and which RADIUS attributes are included in the messages. Standard RADIUS messages and attributes are used whenever possible; however, RADIUS does not have attributes to record all important session information.

Possible messages are:

- Start—Marks the start of service delivery and describes the type of service being delivered and the user to whom it is being delivered
- Interim-Update—Indicates to the accounting server that the session parameters have changed
- Stop—
 - Marks the end of service delivery

- Describes the type of service that was delivered
- Sometimes describes statistics such as elapsed time, input and output octets, or input and output packets
- On—Marks the start of accounting
- Off—Marks the end of accounting

VSAs are used to record the necessary session information missing from this list of standard RADIUS attributes.

For more information about RADIUS, see to the following Internet Engineering Task Force Request for Comments (IETF RFCs):

- RFC 2865, Remote Authentication Dial In User Service (RADIUS), Rigney, et al., June 2000 (<http://www.ietf.org/rfc/rfc2865.txt>)
- RFC 2866, RADIUS Accounting, C. Rigney, June 2000 (<http://www.ietf.org/rfc/rfc2866.txt>)

Standard RADIUS Attributes Dictionary

The table below lists and describes standard RADIUS attributes.

Attribute Name	Attribute Description	Attribute Value	Attribute Value Type	Messages
NAS-IP-Address	IP address of the SIP proxy or the H.323 stack's call signaling address.	4	IP address	<ul style="list-style-type: none"> • Start • Interim-Update • Stop • On • Off
NAS-Port	SIP proxy port or the H.323 stack's call signaling RAS port.	5	integer	<ul style="list-style-type: none"> • Start • Interim-Update • Stop • On • Off
Called-Station-Id	To field value of the SIP INVITE message (a type of message used to initiate a session) or the calledPartyNumber of the H.323 message.	30	string	<ul style="list-style-type: none"> • Start • Interim-Update • Stop
Calling-Station-Id	From field value of the SIP INVITE message or the callingPartyNumber of the H.323 message.	31	string	<ul style="list-style-type: none"> • Start • Interim-Update • Stop

Attribute Name	Attribute Description	Attribute Value	Attribute Value Type	Messages
NAS-Identifier	<p>Value, if any, set in the optional NAS-ID field for the accounting server that you configure as part of the accounting configuration. This identifier sets the value that the remote server (the accounting server) uses to identify the OCSBC so that RADIUS messages can be transmitted.</p> <p>The remote server to which the accounting configuration will send messages uses at least one of two pieces of information for identification:</p> <p>NAS IP address: always included in the accounting message</p> <p>NAS identifier: configured in the NAS-ID parameter of the accounting server; if configured, the NAS identifier is sent to the remote server</p> <p>This attribute only appears if a value is configured in the NAS-ID field.</p>	32	string	<ul style="list-style-type: none"> • Start • Interim-Update • Stop • On • Off
Acct-Status-Type	Whether this Accounting Request marks the beginning of the RADIUS message (Start), the middle (Interim-Update), or the end (Stop), and whether the accounting function is on or off (Accounting-On or Accounting-Off).	40	integer	<ul style="list-style-type: none"> • Start (1) • Interim-Update • Stop (2) • On • Off
Acct-Session-Id	Either the Call-ID field value of the SIP INVITE message, the callIdentifier of the H.323 message, or RADIUS client information.	44	string	<ul style="list-style-type: none"> • Start • Interim-Update • Stop • On • Off
Acct-Session-Time	How much time in seconds (or milliseconds if so configured) the user has received service.	46	integer	<ul style="list-style-type: none"> • Interim-Update • Stop • Off
Acct-Terminate-Cause	How or why the session ended.	49	integer	<ul style="list-style-type: none"> • Stop • Off

RADIUS Accounting Termination Causes

The table below describes the possible session termination causes for the Acct-Terminate-Cause RADIUS attribute.

RADIUS Termination Cause	Related Integer Value (per RFC 2059)	Termination Event	Message
User Request	1	A SIP BYE message.	Stop
User Error	17	Input from user is erroneous; for example, SIP signaling failed to establish the session. Used in combination with the Cisco Systems Disconnect Cause. (This termination cause is not used for H.323.)	Stop
Lost Service	3	Service cannot be sustained for reasons such as a lost connection.	Stop
idle-timeout	4	Idle timer expired.	Stop
session-timeout	5	Maximum session length timer expired.	Stop
Admin Reset	6	OCSBC hard reset occurred: A hard reset occurs when you use the front panel's orange Reset button; it reboots the OCSBC.	Off
Admin Reboot	7	OCSBC gracefully rebooted.	Off
NAS Request	10	RADIUS server is disabled; session terminated for non-error reason.	Off

VSAs

This section describes the VSAs that the OCSBC supports. These attributes appear along with standard RADIUS attributes in the CDRs that the OCSBC generates.

VSAs are defined by vendors of remote access servers in order to customize how RADIUS works on their servers. This section describes the accounting VSAs for Oracle and for Cisco Systems.

Oracle RADIUS VSAs

Oracle's vendor identification number is 9148. This number refers to the 4-octet VSA Vendor-ID field. The high-order octet is 0 and the low-order 3 octets are the SMI Network Management Private Enterprise Code of the Vendor in network byte order, defined in the Assigned Numbers RFC (<http://www.faqs.org/rfcs/rfc1700.html>; Reynolds, J. and J. Postel, Assigned Numbers, STD 2, RFC 1700, October 1994).

The table in this section is a dictionary of Oracle's accounting VSAs. You can use this information to translate the Oracle VSAs in OCSBC RADIUS messages into human-readable form. Oracle maintains VSA dictionary definition files for the most popular RADIUS distributions; ask your Oracle account representative for details.

Grouped according to attribute function, this table contains the following sections:

- **General Flow Attributes**—Overall traits of the media flow, these attributes appear in all CDRs regardless of the session's protocol; these attribute fields are only populated if there are media flows
- **Inbound Flow Attributes**—Detailed traits of the inbound media flow (including realm, remote IP address and port, and local IP address and port); these attribute fields are only populated if there are media flows

- Outbound Flow Attributes—Detailed traits of the outbound media flow (including realm, remote IP address and port, and local IP address and port); these attribute field are only populated if there are media flows
- Session Attributes—Information about the protocol type, ingress and egress realms used, and an identifier that links the H.323 and SIP legs of a call requiring IWF
- QoS Attributes—RADIUS call records are instantiated by individual signaling applications on the OCSBC. The OCSBC writes the following additional parameters to the call record for QoS (Quality of Service):
 - MSRP Total Packets
 - MSRP Total Octets
 - RTP Lost packets
 - RTP Jitter
 - RTP Maximum Jitter
 - RTCP Lost packets
 - RTCP Jitter
 - RTCP Latency
 - RTCP Maximum Latency
 - RTP Total Packets
 - RTP Total Octets

Only RADIUS Stop records contain QoS information. For non-QoS calls, the attributes appear in the record, but their values are always be zero (0). When you review the list of QoS VSAs, please note that “calling” in the attribute name means the information is sent by the calling party and called in the attribute name means the information is sent by the called party.

Examples of how this information appears in CDRs appears in Appendix A of this guide. Please note that the contents of Interim-Update messages do not depend on what events cause a Start message to be generated.

R-Factor and MOS

The OCSBC reports R-Factor and MOS data for the calling and called segments at the end of a session. This information appears in RADIUS CDRs, and in the Oracle VSA dictionary:

- Acme-Calling-R-Factor (151)
- Acme-Calling-MOS (152)
- Acme-Called-R-Factor (153)
- Acme-Called-MOS (154)

Note:

These values are reported as * 100 in order to appear as integers.

Media Flow Attributes

The OCSBC records media flow attributes in RADIUS CDRs, and there can be multiple flows per session. In order to distinguish between the two flows that appear for a basic session (forward and reverse), the OCSBC supports unique media flow attribute names.

The term flow-set represents a pair of media flows, where one is the forward flow and one is the reverse. The flow attributes described in the table below have the designation FS1 or FS2, which identifies it as either the first or the second flow-set. In addition, all non-QoS attributes have a direction indicator: F for forward, and R for reverse.

MSRP Attributes

An additional group of MSRP media flow attributes are captured in the Acme-Extended-Attributes VSA. See [Acme-Extended-Attributes Explanation](#) for information on configuring them.

Attribute Name	Attribute Description	Attribute Value	Attribute Value Type	Messages
Acme-CDR-Sequence-Number	Sequence number (that increases by 1) the OCSBC generates; recorded in each CDR.	59	integer	Start Interim-Update Stop
Acme-Intermediate-Time	Time interval at which periodic interim records are generated during a call.	63	string	Interim-Update
Acme-Local-Time-Zone	Local GMT/UTC time zone that is provisioned on the OCSBC.	57	string	Start Interim-Update Stop
Acme-Firmware-Version	Current software version running on the OCSBC.	56	string	Start Interim-Update Stop

This table lists and describes general flow attributes.

Attribute Name	Attribute Description	Attribute Value	Attribute Value Type	Messages
Acme-FlowID_FS1_F	Unique identifier for every media flow processed by the OCSBC, flow-set 1 forward direction. This VSA always prefaces other flow information.	1	string	Start Interim-Update Stop On Off

Attribute Name	Attribute Description	Attribute Value	Attribute Value Type	Messages
Acme-FlowID_FS1_R	Unique identifier for every media flow processed by the OCSBC, flow-set 1 reverse direction. This VSA always prefaces other flow information.	78	string	Start Interim-Update Stop On Off
Acme-FlowID_FS2_F	Unique identifier for every media flow processed by the OCSBC, flow-set 2 forward direction. This VSA always prefaces other flow information.	90	string	Start Interim-Update Stop On Off
Acme-FlowID_FS2_R	Unique identifier for every media flow processed by the OCSBC, flow-set 2 reverse direction. This VSA always prefaces other flow information.	112	string	Start Interim-Update Stop On Off
Acme-FlowType_FS1_F	Codec that describes the flow, flow-set 1 forward direction: PCMU, PCMA, G722, G726, G723, G728, G729, H261, H263, T38.	2	string	Start Interim-Update Stop On Off
Acme-FlowType_FS1_R	Codec that describes the flow, flow-set 1 reverse direction: PCMU, PCMA, G726, G723, G728, G729, H261, H263, T38.	79	string	Start Interim-Update Stop On Off
Acme-FlowType_FS2_F	Codec that describes the flow, flow-set 2 forward direction: PCMU, PCMA, G726, G723, G728, G729, H261, H263, T38.	91	string	Start Interim-Update Stop On Off

Attribute Name	Attribute Description	Attribute Value	Attribute Value Type	Messages
Acme-FlowType_FS2_R	Codec that describes the flow, flow-set 2 reverse direction: PCMU, PCMA, G726, G723, G728, G729, H261, H263, T38.	113	string	Start Interim-Update Stop On Off

This table describes inbound flow attributes.

Attribute Name	Attribute Description	Attribute Value	Attribute Value Type	Messages
Acme-Flow-In-Realm_FS1_F	Inbound realm identifier for flow-set 1, forward direction.	10	string	Start Interim-Update Stop
Acme-Flow-In-Realm_FS1_R	Inbound realm identifier for flow-set 1, reverse direction.	80	string	Start Interim-Update Stop
Acme-Flow-In-Realm_FS2_F	Inbound realm identifier for flow-set 2, forward direction.	92	string	Start Interim-Update Stop
Acme-Flow-In-Realm_FS2_R	Inbound realm identifier for flow-set 2, reverse direction.	114	string	Start Interim-Update Stop
Acme-Flow-In-Src-Addr_FS1_F	Inbound source address (remote) information for flow-set 1, forward direction.	11	IP address	Start Interim-Update Stop
Acme-Flow-In-Src-Addr_FS1_R	Inbound source address (remote) information for flow-set 1, reverse direction.	81	IP address	Start Interim-Update Stop
Acme-Flow-In-Src-Addr_FS2_F	Inbound source address (remote) information for flow-set 2, forward direction.	93	IP address	Start Interim-Update Stop
Acme-Flow-In-Src-Addr_FS2_R	Inbound source address (remote) information for flow-set 2, reverse direction.	115	IP address	Start Interim-Update Stop

Attribute Name	Attribute Description	Attribute Value	Attribute Value Type	Messages
Acme-Flow-In-Src-Port_FS1_F	Inbound source (remote) port information for flow-set 1, forward direction.	12	integer	Start Interim-Update Stop
Acme-Flow-In-Src-Port_FS1_R	Inbound source (remote) port information for flow-set 1, reverse direction.	82	integer	Start Interim-Update Stop
Acme-Flow-In-Src-Port_FS2_F	Inbound source (remote) port information for flow-set 2, forward direction.	94	integer	Start Interim-Update Stop
Acme-Flow-In-Src-Port_FS2_R	Inbound source (remote) port information for flow-set 2, reverse direction.	116	integer	Start Interim-Update Stop
Acme-Flow-In-Dst-Addr_FS1_F	Inbound destination (local) address information (the IPv4 address field value of the steering pool configuration) for flow-set 1, forward direction.	13	IP address	Start Interim-Update Stop
Acme-Flow-In-Dst-Addr_FS1_R	Inbound destination (local) address information (the IPv4 address field value of the steering pool configuration) for flow-set 1, reverse direction.	83	IP address	Start Interim-Update Stop
Acme-Flow-In-Dst-Addr_FS2_F	Inbound destination (local) address information (the IPv4 address field value of the steering pool configuration) for flow-set 2, forward direction.	95	IP address	Start Interim-Update Stop

Attribute Name	Attribute Description	Attribute Value	Attribute Value Type	Messages
Acme-Flow-In-Dst-Addr_FS2_R	Inbound destination (local) address information (the IPv4 address field value of the steering pool configuration) for flow-set 2, reverse direction.	117	IP address	Start Interim-Update Stop
Acme-Flow-In-Dst-Port_FS1_F	Inbound destination (local) port information (a port in the range between the start port and end port field values of the steering pool configuration) for flow-set 1, forward direction.	14	integer	Start Interim-Update Stop
Acme-Flow-In-Dst-Port_FS1_R	Inbound destination (local) port information (a port in the range between the start port and end port field values of the steering pool configuration) for flow-set 1, reverse direction.	84	integer	Start Interim-Update Stop
Acme-Flow-In-Dst-Port_FS2_F	Inbound destination (local) port information (a port in the range between the start port and end port field values of the steering pool configuration) for flow-set 2, forward direction.	96	integer	Start Interim-Update Stop

Attribute Name	Attribute Description	Attribute Value	Attribute Value Type	Messages
Acme-Flow-In-Dst-Port_FS2_R	Inbound destination (local) port information (a port in the range between the start port and end port field values of the steering pool configuration) for flow-set 2, reverse direction.	118	integer	Start Interim-Update Stop

This table lists and describes outbound flow attributes.

Attribute Name	Attribute Description	Attribute Value	Attribute Value Type	Messages
Acme-Flow-Out-Realm_FS1_F	Outbound realm identifier for flow-set 1, forward direction.	20	string	Start Interim-Update Stop
Acme-Flow-Out-Realm_FS1_R	Outbound realm identifier for flow-set 1, reverse direction.	85	string	Start Interim-Update Stop
Acme-Flow-Out-Realm_FS2_F	Outbound realm identifier for flow-set 2, forward direction.	97	string	Start Interim-Update Stop
Acme-Flow-Out-Realm_FS2_R	Outbound realm identifier for flow-set 2, reverse direction.	119	string	Start Interim-Update Stop
Acme-Flow-Out-Src-Addr_FS1_F	Outbound source (local) address information (the IPv4 address field value of the steering port configuration) for flow-set 1, forward direction.	21	IP address	Start Interim-Update Stop
Acme-Flow-Out-Src-Addr_FS1_R	Outbound source (local) address information (the IPv4 address field value of the steering port configuration) for flow-set 1, reverse direction.	86	IP address	Start Interim-Update Stop

Attribute Name	Attribute Description	Attribute Value	Attribute Value Type	Messages
Acme-Flow-Out- Src-Addr_FS2_F	Outbound source (local) address information (the IPv4 address field value of the steering port configuration) for flow-set 2, forward direction.	98	IP address	Start Interim-Update Stop
Acme-Flow-Out- Src-Addr_FS2_R	Outbound source (local) address information (the IPv4 address field value of the steering port configuration) for flow-set 2, reverse direction.	120	IP address	Start Interim-Update Stop
Acme-Flow-Out- Src-Port_FS1_F	Outbound source (local) port information for flow-set 1, forward direction (a port in the range between the start port and end port field values of the steering port configuration).	22	integer	Start Interim-Update Stop
Acme-Flow-Out- Src-Port_FS1_R	Outbound source (local) port information for flow-set 1, reverse direction (a port in the range between the start port and end port field values of the steering port configuration).	87	integer	Start Interim-Update Stop
Acme-Flow-Out- Src-Port_FS2_F	Outbound source (local) port information for flow-set 2, forward direction (a port in the range between the start port and end port field values of the steering port configuration).	99	integer	Start Interim-Update Stop

Attribute Name	Attribute Description	Attribute Value	Attribute Value Type	Messages
Acme-Flow-Out- Src-Port_FS2_R	Outbound source (local) port information for flow-set 2, reverse direction (a port in the range between the start port and end port field values of the steering port configuration).	121	integer	Start Interim-Update Stop
Acme-Flow-Out- Dst-Addr_FS1_F	Outbound destination (remote) address information for flow-set 1, forward direction.	23	IP address	Start Interim-Update Stop
Acme-Flow-Out- Dst-Addr_FS1_R	Outbound destination (remote) address information for flow-set 1, reverse direction.	88	IP address	Start Interim-Update Stop
Acme-Flow-Out- Dst-Addr_FS2_F	Outbound destination (remote) address information for flow-set 2, forward direction.	100	IP address	Start Interim-Update Stop
Acme-Flow-Out- Dst-Addr_FS2_R	Outbound destination (remote) address information for flow-set 2, reverse direction.	122	IP address	Start Interim-Update Stop
Acme-Flow-Out- Dst-Port_FS1_F	Outbound destination (remote) port information for flow-set 1, forward direction.	24	integer	Start Interim-Update Stop
Acme-Flow-Out- Dst-Port_FS1_R	Outbound destination (remote) port information for flow-set 1, reverse direction.	89	integer	Start Interim-Update Stop
Acme-Flow-Out- Dst-Port_FS2_F	Outbound destination (remote) port information for flow-set 2, forward direction.	101	integer	Start Interim-Update Stop

Attribute Name	Attribute Description	Attribute Value	Attribute Value Type	Messages
Acme-Flow-Out-Dst-Port_FS2_R	Outbound destination (remote) port information for flow-set 2, reverse direction.	123	integer	Start Interim-Update Stop

This table lists and describes session attributes.

Attribute Name	Attribute Description	Attribute Value	Attribute Value Type	Messages
Acme-Session-Generic-Id	Common ID shared by H.323 and SIP call legs of a session. This attribute is a combination of a time stamp (measured in seconds) and a monotonically increasing 16-bit integer, followed by an at-sign (@) and the MAC address of the rear interface (wancom). This attribute is only used to correlate the H.323 and SIP legs of an interworking call/session. This VSA is not configurable; all CDRs contain this attribute.	40	string	Start Interim-Update Stop
Acme-Session-Ingress-CallId	Call ID generated by the originating device.	3	string	Start Interim-Update Stop
Acme-Session-Egress-CallId	Call ID generated by the OCSBC to represent a two-way transaction.	4	string	Start Interim-Update Stop

Attribute Name	Attribute Description	Attribute Value	Attribute Value Type	Messages
Acme-Session-Ingress-Realm	Explicitly identifies the ingress realm, and contains the name of the ingress realm for the session. All CDRs contain this attribute. This VSA is not configurable; all CDRs contain this attribute.	41	string	Start Interim-Update Stop
Acme-Session-Egress-Realm	Explicitly identifies the egress realm, and contains the name of the egress realm for the session. All CDRs contain this attribute. This VSA is not configurable. All CDRs contain this attribute, but it is only populated if an egress realm is found; a call without a route does not have an egress realm.	42	string	Start Interim-Update Stop
Acme-Session-Protocol-Type	Signaling protocol used for a particular leg of a session (in the case of IWF, there may be two legs). This attribute contains the signaling protocol type; for example, SIP or H323. This VSA is not configurable; all CDRs contain this attribute.	43	string	Start Interim-Update Stop

Attribute Name	Attribute Description	Attribute Value	Attribute Value Type	Messages
Acme-Session-Charging-Vector	Appears when the OCSBC inserts, passes, or deletes the P-Charging-Vector header (SIP). This attribute is only populated for SIP CDRs, and is not populated if the OCSBC does not have P-Charging-Vector information.	54	string	Start Interim-Update Stop
Acme-Session-Charging-Function_Addresses	Appears when the OCSBC inserts, passes, or deletes the P-Charging-Function-Address. This attribute is only populated for SIP CDRs, and is not populated if the OCSBC does not have P-Charging-Function-Address information.	55	string	Start Interim-Update Stop
Acme-Session-Disposition	Status of the call attempt as it progresses from being initiated (using a SIP INVITE or H.323 Setup message) to being either answered or failing to be answered.	60	integer	Start Interim-Update Stop
Acme-Post-Dial-Delay	Amount of time between session initiation and an alerting event.	58	integer	Start Interim-Update Stop
Acme-P-Asserted-ID	P-Asserted ID as described in RFC 3325.	69	string	Start Interim-Update Stop

Attribute Name	Attribute Description	Attribute Value	Attribute Value Type	Messages
Acme-SIP-Diversion	SIP Diversion header; communicates to the called party from whom and why a call diverted.	70	string	Start Interim-Update Stop
Acme-Primary-Routing-Number	Primary routing number and phone context (or ingress SIP Request-URI).	64	string	Start Interim-Update Stop
Acme-Egress-Final-Routing-Number	Final routing number and phone context (or egress SIP Request-URI).	134	integer	Stop
Acme-Disconnect-Initiator	Initiator of a call disconnect.	61	integer	Stop
Acme-Disconnect-Cause	Q.850 cause code value.	62	integer	Stop
Acme-SIP-Status	SIP status code for RFC 3326 support.	71	integer	Stop
Acme-Originating-Trunk-Group	Originating trunk group.	65	string	Start Interim-Update Stop
Acme-Originating-Trunk-Context	Originating trunk group context.	67	string	Start Interim-Update Stop
Acme-Terminating-Trunk-Group	Terminating trunk group.	66	string	Start Interim-Update Stop
Acme-Terminating-Trunk-Context	Terminating trunk group context.	68	string	Start Interim-Update Stop
Acme-Ingress-Local-Addr	Signaling IP address and port of the ingress OCSBC signaling interface.	74	string	Start Interim-Update Stop
Acme-Ingress-Remote-Addr	Signaling IP address and port of the ingress remote signaling element.	75	string	Start Interim-Update Stop

Attribute Name	Attribute Description	Attribute Value	Attribute Value Type	Messages
Acme-Egress-Local-Addr	Signaling IP address and port of the egress OCSBC signaling interface.	76	string	Start Interim-Update Stop
Acme-Egress-Remote-Addr	Signaling IP address and port of the destination signaling element.	77	string	Start Interim-Update Stop
Acme-Session-Ingress-RPH	RPH value received in the incoming call (e.g., ets.1). Only populated for NSEP calls.	135	string	Start Interim-Update Stop
Acme-Session-Egress-RPH	RPH value sent in the outgoing call (e.g., ets.3). Only populated for NSEP calls.	136	string	Start Interim-Update Stop
Acme-Ingress-Network-Interface-Id	To differentiate overlapping IP address spaces (with the Acme-Ingress-Vlan-Tag-Value), gives the ID of the ingress network interface.	137	string	Start Interim-Update Stop
Acme-Ingress-Vlan-Tag-Value	To differentiate overlapping IP address spaces (with the Acme-Ingress-Network-Interface-Id), gives the VLAN tag.	138	integer	Start Interim-Update Stop
Acme-Egress-Network-Interface-Id	To differentiate overlapping IP address spaces (with the Acme-Egress-Vlan-Tag-Value), gives the ID of the ingress network interface.	139	string	Start Interim-Update Stop
Acme-Egress-Vlan-Tag-Value	To differentiate overlapping IP address spaces (with the Acme-Egress-Network-Interface-Id), gives the VLAN tag.	140	integer	Start Interim-Update Stop

Attribute Name	Attribute Description	Attribute Value	Attribute Value Type	Messages
Acme-Refer-Call-Transfer-Id	For SIP REFER call method transfer, communicates a call has been transferred from the referer to the referree	141	string	Stop

This table lists and describes QoS attributes.

Attribute Name	Attribute Description	Attribute Value	Attribute Value Type	Messages
Acme-Calling-RTCP-Packets-Lost_FS1	Total lost packets reported via Real-time Transport Protocol Control Protocol (RTCP), flow-set 1. Populated only if QoS is enabled.	32	integer	Stop
Acme-Calling-RTCP-Packets-Lost_FS2	Total lost packets reported via Real-time Transport Protocol Control Protocol (RTCP), flow-set 2. Populated only if QoS is enabled.	104	integer	Stop
Acme-Calling-RTCP-Avg-Jitter_FS1	Average jitter reported via RTCP measured in milliseconds, flow-set 1. Populated only if QoS is enabled.	33	integer	Stop
Acme-Calling-RTCP-Avg-Jitter_FS2	Average jitter reported via RTCP measured in milliseconds, flow-set 2. Populated only if QoS is enabled.	105	integer	Stop

Attribute Name	Attribute Description	Attribute Value	Attribute Value Type	Messages
Acme-Calling-RTCP-Avg Latency_FS1	Average latency reported by comparing the timestamps in RTCP packets for each direction of a call, flow-set 1. Populated only if QoS is enabled.	34	integer	Stop
Acme-Calling-RTCP-Avg Latency_FS2	Average latency reported by comparing the timestamps in RTCP packets for each direction of a call, flow-set 2. Populated only if QoS is enabled.	106	integer	Stop
Acme-Calling-RTCP-MaxJitter_FS1	Maximum amount of jitter value reported via RTCP measured in milliseconds, flow-set 1. Populated only if QoS is enabled.	35	integer	Stop
Acme-Calling-RTCP-MaxJitter_FS2	Maximum amount of jitter value reported via RTCP measured in milliseconds, flow-set 3. Populated only if QoS is enabled.	107	integer	Stop
Acme-Calling-RTCP-MaxLatency_FS1	Maximum latency value measured in milliseconds as observed through RTCP, flow-set 1. Populated only if QoS is enabled.	36	integer	Stop
Acme-Calling-RTCP-MaxLatency_FS2	Maximum latency value measured in milliseconds as observed through RTCP, flow-set 2. Populated only if QoS is enabled.	108	integer	Stop
Acme-Calling-Octets_FS1	Bytes of RTP traffic for this call, flow-set 1. Populated only if QoS is enabled.	28	integer	Stop

Attribute Name	Attribute Description	Attribute Value	Attribute Value Type	Messages
Acme-Calling-Octets_FS2	Bytes of RTP traffic for this call, flow-set 2. Populated only if QoS is enabled.	102	integer	Stop
Acme-Calling-Packets_FS1	Number of RTP Packets, received by the SBC, from the calling party, for flow-set 1. Populated only if QoS is enabled.	29	integer	Stop
Acme-Calling-Packets_FS2	Number of RTP Packets, received by the SBC, from the calling party, for flow-set 2. Populated only if QoS is enabled.	103	integer	Stop
Acme-Calling-RTP-Packets-Lost_FS1	Total RTP packets lost in flow-set 1. Populated only if QoS is enabled.	37	integer	Stop
Acme-Calling-RTP-Packets-Lost_FS2	Total RTP packets lost in flow-set 2. Populated only if QoS is enabled.	109	integer	Stop
Acme-Calling-RTP-Avg-Jitter_FS1	Total jitter measured on RTP packets in milliseconds, flow-set 1. Populated only if QoS is enabled.	38	integer	Stop
Acme-Calling-RTP-Avg-Jitter_FS2	Total jitter measured on RTP packets in milliseconds, flow-set 2. Populated only if QoS is enabled.	110	integer	Stop
Acme-Calling-RTP-MaxJitter_FS1	Maximum jitter measured on RTP packets in milliseconds, flow-set 1. Populated only if QoS is enabled.	39	integer	Stop

Attribute Name	Attribute Description	Attribute Value	Attribute Value Type	Messages
Acme-Calling-RTP-Avg-MaxJitter_FS2	Maximum jitter measured on RTP packets in milliseconds, flow-set 2. Populated only if QoS is enabled.	111	integer	Stop
Acme-Called-Octets_FS1	Number of Octets (8 bits) of RTP traffic, received by the SBC, from the called party, for flow-set 1. Populated only if QoS is enabled.	44	integer	Stop
Acme-Called-Octets_FS2	Number of Octets (8 bits) of RTP traffic, received by the SBC, from the called party, for flow-set 2. Populated only if QoS is enabled.	124	integer	Stop
Acme-Called-Packets_FS1	Number of RTP Packets, received by the SBC, from the called party, for flow-set 1. Populated only if QoS is enabled.	45	integer	Stop
Acme-Called-Packets_FS2	Number of RTP Packets, received by the SBC, from the called party, for flow-set 2. Populated only if QoS is enabled.	125	integer	Stop
Acme-Called-RTCP-Packets-Lost_FS1	Total lost packets reported via Real-time Transport Protocol Control Protocol (RTCP), flow-set 1. Populated only if QoS is enabled.	46	integer	Stop

Attribute Name	Attribute Description	Attribute Value	Attribute Value Type	Messages
Acme-Called-RTCP-Packets-Lost_FS2	Total lost packets reported via Real-time Transport Protocol Control Protocol (RTCP), flow-set 2. Populated only if QoS is enabled.	126	integer	Stop
Acme-Called-RTCP-Avg-Jitter_FS1	Average jitter reported via RTCP measured in milliseconds for the ingress side of the call, flow-set 1. Populated only if QoS is enabled.	47	integer	Stop
Acme-Called-RTCP-Avg-Jitter_FS2	Average jitter reported via RTCP measured in milliseconds for the ingress side of the call, flow-set 2. Populated only if QoS is enabled.	127	integer	Stop
Acme-Called-Avg-Latency_FS1	Average latency reported via RTCP measured in milliseconds for the ingress side of the call, flow-set 1. Populated only if QoS is enabled.	48	integer	Stop
Acme-Called-Avg-Latency_FS2	Average latency reported via RTCP measured in milliseconds for the ingress side of the call, flow-set 2. Populated only if QoS is enabled.	128	integer	Stop

Attribute Name	Attribute Description	Attribute Value	Attribute Value Type	Messages
Acme-Called-RTCP-MaxJitter_FS1	Maximum amount of jitter reported via RTCP measured in milliseconds for the ingress side of the call, flow-set 1. Populated only if QoS is enabled.	49	integer	Stop
Acme-Called-RTCP-MaxJitter_FS2	Maximum amount of jitter reported via RTCP measured in milliseconds for the ingress side of the call, flow-set 2. Populated only if QoS is enabled.	129	integer	Stop
Acme-Called-RTCP-MaxLatency_FS1	Maximum amount of latency reported via RTCP measured in milliseconds for the ingress side of the call, flow-set 1. Populated only if QoS is enabled.	50	integer	Stop
Acme-Called-RTCP-MaxLatency_FS2	Maximum amount of latency reported via RTCP measured in milliseconds for the ingress side of the call, flow-set 2. Populated only if QoS is enabled.	130	integer	Stop
Acme-Called-RTP-Packets-Lost_FS1	Total lost RTP packets for the ingress side of the call, flow-set 1. Populated only if QoS is enabled.	51	integer	Stop
Acme-Called-RTP-Packets-Lost_FS2	Total lost RTP packets for the ingress side of the call, flow-set 2. Populated only if QoS is enabled.	131	integer	Stop

Attribute Name	Attribute Description	Attribute Value	Attribute Value Type	Messages
Acme-Called-RTP-Avg-Jitter_FS1	Average jitter reported via RTP measured in milliseconds for the ingress side of the realm, flow-set 1. Populated only if QoS is enabled.	52	integer	Stop
Acme-Called-RTP-Avg-Jitter_FS2	Average jitter reported via RTP measured in milliseconds for the ingress side of the realm, flow-set 2. Populated only if QoS is enabled.	132	integer	Stop
Acme-Called-RTP-MaxJitter_FS1	Maximum amount of jitter reported via RTP measured in milliseconds for the ingress side of the call, flow-set1. Populated only if QoS is enabled.	53	integer	Stop
Acme-Called-RTP-MaxJitter_FS2	Maximum amount of jitter reported via RTP measured in milliseconds for the ingress side of the call, flow-set 2. Populated only if QoS is enabled.	133	integer	Stop
Acme-Calling-R-Factor	QoS R-Factor calculation for the calling side of a session. Populated only if QoS is enabled. This value is reported as * 100 in order to appear as an integer.	151	integer	Stop

Attribute Name	Attribute Description	Attribute Value	Attribute Value Type	Messages
Acme-Calling-MOS	QoS MOS calculation for the calling side of a session. Populated only if QoS is enabled. This value is reported as * 100 in order to appear as an integer.	152	integer	Stop
Acme-Called-R-Factor	QoS R-Factor calculation for the called side of a session. Populated only if QoS is enabled. This value is reported as * 100 in order to appear as an integer.	153	integer	Stop
Acme-Called-MOS New in Release	QoS MOS calculation for the called side of a session. Populated only if QoS is enabled. This value is reported as * 100 in order to appear as an integer.	154	integer	Stop
Acme-Session-Forked-Call-Id	The VSA is a string value, and appears as the header-value without the header parameters from the P-Multiring-Correlator header for a session identified as part of a forked call.	171	string	Stop
Acme-Flow-Calling-Media-Stop-Time_FS1	calling side's media stop time - stream 1	231	string	Start Interim-Update Interim-Update (error) Stop
Acme-Flow-Called-Media-Stop-Time_FS1	called side's media stop time - stream 1	232	string	Start Interim-Update Interim-Update (error) Stop

Attribute Name	Attribute Description	Attribute Value	Attribute Value Type	Messages
Acme-Flow-Calling-Media-Stop-Time_FS2	calling side's media stop time - stream 2	233	string	Start Interim-Update Interim-Update (error) Stop
Acme-Flow-Called-Media-Stop-Time_FS2	called side's media stop time - stream 2	234	string	Start Interim-Update Interim-Update (error) Stop

Acme-Extended-Attributes Explanation

As new attributes become available in the RADIUS dictionary, they are accessible on the Acme-Extended-Attributes attribute. These statistics are also available in local CSVs.

MSRP Statistics

MSRP attributes will look like the following when put on one AVP:

```
msrp-attr-type = 0
msrp-attr-len = ...
msrp-attr-data = {1, Acme-MSRP-Calling-
Packets, Acme-MSRP-Calling-octets,
Acme-MSRP-Calling-Packets-Transmitted,
Acme-MSRP-Calling-Octets-Transmitted,
Acme-MSRP-Called-Packets, Acme-MSRP-
Called-Octets,
Acme-MSRP-Called-Packets-transmitted,
Acme-MSRP-Called-Octets-Transmitted}
```

For example, if the value for a call is 0x00230100000001000000f6000000010000009a000000010000009a0000000100000f5, you should create a parser to break up the information as follows:

- Type: 0x00
- Length: 23
- Version: 01
- Calling Packets: 00000001
- Calling Octets: 000000f6
- Calling Packets Transferred: 00000001
- Calling Octets Transferred: 0000009a
- Called Octets: 0000009a
- Called Packets Transferred: 00000001

- Called Octets Transferred: 000000f5

IPv6 Support

The following table lists the media flow attributes for IPv6 flows.

Attribute Name	Attribute Description	Attribute Value	Attribute Value Type	Messages
Acme-Flow-In-Src-IPv6_Addr_FS1_F	Inbound source IPv6 address (remote) information for flow-set 1, forward direction.	155	ipv6addr	Start Interim-Update Stop
Acme-Flow-In-Dst-IPv6_Addr_FS1_F	Inbound destination (local) address information (the IPv6 address field value of the steering pool configuration) for flow-set 1, forward direction.	156	ipv6addr	Start Interim-Update Stop
Acme-Flow-Out-Src-IPv6_Addr_FS1_F	Outbound source (local) address information (the IPv6 address field value of the steering port configuration) for flow-set 1, forward direction.	157	ipv6addr	Start Interim-Update Stop
Acme-Flow-Out-Dst-IPv6_Addr_FS1_F	Outbound destination (remote) IPv6 address information for flow-set 1, forward direction.	158	ipv6addr	Start Interim-Update Stop
Acme-Flow-In-Src-IPv6_Addr_FS1_R	Inbound source IPv6 address (remote) information for flow-set 1, reverse direction.	159	ipv6addr	Start Interim-Update Stop
Acme-Flow-In-Dst-IPv6_Addr_FS1_R	Inbound destination (local) address information (the IPv6 address field value of the steering pool configuration) for flow-set 1, reverse direction.	160	ipv6addr	Start Interim-Update Stop
Acme-Flow-Out-Src-IPv6_Addr_FS1_R	Outbound source (local) address information (the IPv6 address field value of the steering port configuration) for flow-set 1, reverse direction.	161	ipv6addr	Start Interim-Update Stop
Acme-Flow-Out-Dst-IPv6_Addr_FS1_R	Outbound destination (remote) IPv6 address information for flow-set 1, reverse direction.	162	ipv6addr	Start Interim-Update Stop
Acme-Flow-In-Src-IPv6_Addr_FS2_F	Inbound source address (remote) IPv6 information for flow-set 2, forward direction.	163	ipv6addr	Start Interim-Update Stop
Acme-Flow-In-Dst-IPv6_Addr_FS2_F	Inbound destination (local) address information (the IPv6 address field value of the steering pool configuration) for flow-set 2, forward direction.	164	ipv6addr	Start Interim-Update Stop
Acme-Flow-Out-Src-IPv6_Addr_FS2_F	Outbound source (local) address information (the IPv6 address field value of the steering port configuration) for flow-set 2, forward direction.	165	ipv6addr	Start Interim-Update Stop

Attribute Name	Attribute Description	Attribute Value	Attribute Value Type	Messages
Acme-Flow-Out-Dst-IPv6_Addr_FS2_F	Outbound destination (remote) IPv6 address information for flow-set 2, forward direction.	166	ipv6addr	Start Interim-Update Stop
Acme-Flow-In-Src-IPv6_Addr_FS2_R	Inbound source address (remote) IPv6 address information for flow-set 2, reverse direction.	167	ipv6addr	Start Interim-Update Stop
Acme-Flow-In-Dst-IPv6_Addr_FS2_R	Inbound destination (local) address information (the IPv6 address field value of the steering pool configuration) for flow-set 2, reverse direction.	168	ipv6addr	Start Interim-Update Stop
Acme-Flow-Out-Src-IPv6_Addr_FS2_R	Outbound source (local) address information (the IPv6 address field value of the steering port configuration) for flow-set 2, reverse direction.	169	ipv6addr	Start Interim-Update Stop
Acme-Flow-Out-Dst-IPv6_Addr_FS2_R	Outbound destination (remote) IPv6 address information for flow-set 2, reverse direction.	170	ipv6addr	Start Interim-Update Stop
Acme-Flow-Calling-Media-Stop-Time_FS1	calling side's media stop time - stream 1	231	string	Start Interim-Update Interim-Update (error) Stop
Acme-Flow-Called-Media-Stop-Time_FS1	called side's media stop time - stream 1	232	string	Start Interim-Update Interim-Update (error) Stop
Acme-Flow-Calling-Media-Stop-Time_FS2	calling side's media stop time - stream 2	233	string	Start Interim-Update Interim-Update (error) Stop
Acme-Flow-Called-Media-Stop-Time_FS2	called side's media stop time - stream 2	234	string	Start Interim-Update Interim-Update (error) Stop

Oracle VSA Values

The table below defines the possible values for several Oracle VSAs.

Oracle VSA Name	Attribute Value	Possible Values
Acme-PostDial-Delay	58	Unit value in milliseconds

Oracle VSA Name	Attribute Value	Possible Values
Acme-Session-Disposition	60	0=unknown 1=call_attempt 2=ringing 3=answered
Acme-Disconnect-Initiator	61	0=UNKNOWN_DISCONNECT_INITIATOR 1=CALLING_PARTY_DISCONNECT 2=CALLED_PARTY_DISCONNECT 3=INTERNAL_DISCONNECT
Acme-Disconnect-Cause	62	34=No circuit/channel available 47=Resource unavailable 3=No route destination 31=Normal, unspecified 88=Incompatible destination 111=Interworking, unspecified 38=Network out of order 42=Switching equip congestion 28=Invalid number format 41=Temporary failure 17=User busy 16=Normal call clearing 20=Subscriber absent 31=Normal call clearing 18=Request error timeout response 55=Forbidden error response 0=No reason cause presented
Acme-SIP-Diversion	70	SIP Diversion header based on this RFC draft: draft-levy-sip-diversion-05.txt

Oracle VSA Name	Attribute Value	Possible Values
Acme-SIP-Status	71	<p>This is a complete list of support status codes; only a subset would be reported in a Stop record:</p> <p>RESP_STATUS_TRYING 100</p> <p>RESP_STATUS_RINGING 180</p> <p>RESP_STATUS_FORWARD 181</p> <p>RESP_STATUS_QUEUED 182</p> <p>RESP_STATUS_PROGRESS 183</p> <p>RESP_STATUS_OK 200</p> <p>RESP_STATUS_CREATED 201</p> <p>RESP_STATUS_ACCEPTED 202</p> <p>RESP_STATUS_PART 206</p> <p>RESP_STATUS_MAX_OK 299</p> <p>RESP_STATUS_MULTIPLE 300</p> <p>RESP_STATUS_MOVED 301</p> <p>RESP_STATUS_MOVED_TMP 302</p> <p>RESP_STATUS_USE_PROXY 305</p> <p>RESP_STATUS_ALTERNATE 380</p> <p>RESP_STATUS_BAD 400</p> <p>RESP_STATUS_UNAUTH 401</p> <p>RESP_STATUS_PAY_REQ 402</p> <p>RESP_STATUS_FORBIDDEN 403</p> <p>RESP_STATUS_NOT_FOUND 404</p> <p>RESP_STATUS_NOT_ALLOW 405</p> <p>RESP_STATUS_NOT_ACCEPT 406</p> <p>RESP_STATUS_AUTH_REQ 407</p> <p>RESP_STATUS_REQ_TMO 408</p> <p>RESP_STATUS_CONFLICT 409</p> <p>RESP_STATUS_GONE 410</p> <p>RESP_STATUS_LEN_REQ 411</p> <p>RESP_STATUS_TOO_BIG 413</p> <p>RESP_STATUS_URI_TOO_BIG 414</p> <p>RESP_STATUS_MEDIA 415</p> <p>RESP_STATUS_URI_SCHEME 416</p> <p>RESP_STATUS_BAD_EXT 420</p> <p>RESP_STATUS_EXT_REQ 421</p> <p>RESP_STATUS_TOO_SMALL 422</p> <p>RESP_STATUS_TOO_BRIEF 423</p> <p>RESP_STATUS_TMP_UNAVAIL 480</p> <p>RESP_STATUS_NO_EXIST 481</p> <p>RESP_STATUS_LOOP 482</p> <p>RESP_STATUS_TOOMNY_HOPS 483</p> <p>RESP_STATUS_ADDR_INCMPL 484</p> <p>RESP_STATUS_AMBIGUOUS 485</p> <p>RESP_STATUS_BUSY_HERE 486</p> <p>RESP_STATUS_CANCELLED 487</p> <p>RESP_STATUS_NOT_HERE 488</p>

Oracle VSA Name	Attribute Value	Possible Values
		RESP_STATUS_BAD_EVENT 489
		RESP_STATUS_PENDING 491
		RESP_STATUS_UNDECIPH 493
		RESP_STATUS_INT_ERR 500
		RESP_STATUS_NOT_IMPL 501
		RESP_STATUS_BAD_GTWY 502
		RESP_STATUS_SVC_UNAVAIL 503
		RESP_STATUS_GTWY_TMO 504
		RESP_STATUS_BAD_VER 505
		RESP_STATUS_MSG_TOO_BIG 513
		RESP_STATUS_PRE_FAIL 580
		RESP_STATUS_BUSY 600
		RESP_STATUS_DECLINE 603
		RESP_STATUS_DONT_EXIST 604
		RESP_STATUS_NOTACCEPT 606

Authentication VSAs

The table below defines Oracle VSAs used for RADIUS authentication.

Oracle VSA Name	Attribute Value	Attribute Values
Acme-User-Privilege	Describes at RADIUS login the privileges granted to the administrator (VSA only available with admin security license installed). Values can be: sftpForAudit (SFTP is allowed for audit logs) sftpForAll (SFTP is allowed for logging, and audit logs)	253
Acme-User-Class	Identifies the type user on the OCSBC; used for RADIUS authentication only and does not apply to accounting. Values can be user, admin, and SystemAdmin (only with admin security license installed).	254

Cisco Systems RADIUS Decodes

The following table is a dictionary of the Cisco Systems (vendor identification number is 9) accounting VSAs. These attribute names are vendor-specific and subject to change without notice.

You can use the information in this table to translate the Cisco Systems VSAs that sometimes appear in OCSBC RADIUS messages into a more human-readable form.

Attribute Name	Attribute Description	Attribute Value	Attribute Value Type	Messages
Setup Time	The SETUP message is used to request a connection (and therefore corresponds with the SIP INVITE). Start record—Time that the first SIP INVITE or H.323 SETUP message was received. Interim record—Time that the applicable SIP REINVITE message was received. Stop record—Time that the last SIP REINVITE message was received.	25	string	Start Interim Stop
Connect Time	Time that a SIP or H.323 session was accepted. This is the time a 200 OK SIP response to the SIP INVITE message was received or the time that a call ANSWERED/CONNECTED response to the H.323 SETUP message was received.	28	string	Start Interim-Update Stop
Disconnect Time	Time that a SIP BYE or H.323 Release Complete message was received or the session terminated. This is the time a SIP INVITE or H.323 SETUP transaction terminates for any reason.	29	string	Stop
Disconnect Cause	SIP Reasons for Disconnection (normal, redirection, client error, network error, global error, time-out, or user abandon) or the H.323 Release Complete Reason code (bad format address, unavailable, destination rejection, adaptive busy, etc.). For more information, refer to this guide's Mappings and Disconnect Cause Values section.	30	string	Stop

Mappings and Disconnect Cause Values

This section provides information about H.323 and SIP disconnect cause values for RADIUS CDRs generated by the OCSBC.

SIP H.323 and Q.850 Mappings

This section provides tables that show the mappings between SIP Status and: H.323 Disconnect Reason, H.323 Release Complete Reason, and RAS error. It also shows the mapping for Q.850 cause to H.323 Release Complete Reason.

SIP Status to H.323 Disconnect Reason Mapping

SIP Status	H.323 Disconnect Reason
480 Temporarily Unavailable	No Bandwidth
404 Not Found	Gatekeeper Resource
404 Not Found	Unreachable Destination
603 Decline	Destination Rejection
505 Version Not Supported	Invalid Revision
401 Unauthorized	No Permission
503 Service Unavailable	Unreachable Gatekeeper
480 Temporarily Unavailable	Gateway Resource
400 Bad Request	Bad Format Request
486 Busy Here	Adaptive Busy
486 Busy Here	In Conference
500 Internal Server Error	Undefined Reason
486 Busy Here	Facility Call Deflection
401 Unauthorized	Security Denied

SIP Status to H.323 RAS Error Mapping

SIP Status	H.323 RAS Error
404 Not Found	Gatekeeper Resource
401 Unauthorized	Invalid Permission
503 Service Unavailable	Request Denied
500 Internal Server Error	Undefined
401 Unauthorized	Caller Not Registered
305 User Proxy	Route Call to Gatekeeper
500 Internal Server Error	Invalid Endpoint ID
503 Service Unavailable	Resource Unavailable
401 Unauthorized	Security Denial
501 Not Implemented	QoS Control Not Supported
484 Address Incomplete	Incomplete Address
302 Moved Temporarily	Route Call to SCN
485 Ambiguous	Aliases Inconsistent
401 Unauthorized	Not Currently Registered

SIP Status to H.323 Release Complete Reason Error Mapping

SIP Status	H.323 RAS Error
300 Multiple Choices	Undefined Reason
401 Unauthorized	Security Denied
402 Payment Required	Undefined Reason
403 Forbidden	No Permission
404 Not Found	Unreachable Destination

SIP Status	H.323 RAS Error
405 Method Not Allowed	Undefined Reason
606 Not Acceptable	Undefined Reason
407 Proxy Authentication Required	Security Denied
408 Request Timeout	Adaptive Busy
409 Conflict	Undefined Reason
410 Gone	Unreachable Destination
411 Length Required	Undefined Reason
414 Request-URI Too Large	Bad Format Address
415 Unsupported Media Type	Undefined Reason
420 Bad Extension	Bad Format Address
480 Temporarily Unavailable	Adaptive Busy
481 Call/Transaction Does Not Exist	Undefined Reason
482 Loop Detected	Undefined Reason
483 Too Many Hops	Undefined Reason
484 Address Incomplete	Bad Format Address

Q.850 Cause to H.323 Release Complete Reason Mapping

The table below describes how the Q.850 Causes and the H.323 release complete reasons are mapped internally on the OCSBC.

Q.850 Cause	Numeric Code	H.323 Release Complete Reason
Not Route To Destination	3	Unreachable Destination
Normal Call Clearing	16	Destination Rejection
User Busy	17	In Conference
Subscriber Absent	20	Called Party Not Registered
Invalid Number Format	28	Bad Format Address
Normal Unspecified	16	Undefined Reason
No Circuit/Channel Available	34	No Bandwidth
Network Out of Order	38	Unreachable Gatekeeper
Temporary Failure	41	Adaptive Busy
Switching Equipment Congestion	42	Gateway Resource
Resource Unavailable	47	Gatekeeper Resource
Incompatible Destination	88	Invalid Revision
Interworking Unspecified	111	No Permission

SIP-SIP Calls

The OCSBC maps SIP status codes and events to disconnect cause attribute values used by Cisco Systems Proxy Server (CSPS) accounting services.

SIP Status Category/ Event	CDR Disconnect Cause	Description
Undetermined reason	0	Undetermined reason

SIP Status Category/ Event	CDR Disconnect Cause	Description
BYE	1	Normal clearing
3xx: Redirection	2	Redirection
4xx: Client Error	3	Client error
5xx: Server Error	4	Server error
6xx: Global Failure	5	Global error

SIP-H.323 Calls with Interworking

For calls that require SIP-H.323 interworking, the OCSBC generates two sets of RADIUS CDRs: one for the SIP call-leg and one for the H.323 call leg. The values recorded in RADIUS Stop records for the disconnect cause depend on the nature and source of the call disconnect or rejection.

SIP Events and Errors

For calls rejected or disconnected because of SIP events and errors, the OCSBC records Q.850 cause values mapped from the SIP event/status code in the SIP CDR. For the H.323 CDR, the SIP status categories and events are mapped to Q.850 cause codes.

The entries in this table are determined by the [SIP Status to H.323 Release Complete Reason Error Mapping](#).

SIP Status Category/ Event	SIP CDR Disconnect Cause	H.323 Disconnect Cause Value (Q.850)
BYE	16—Normal call clearing	16—Normal call clearing
3xx	23—Redirection to new destination	16—Normal call clearing
404 Not Found	21—Call rejected	3—No route to destination
410 Gone	21—Call rejected	3—No route to destination
403 Forbidden	21—Call rejected	111—Interworking unspecified
408 Request Timeout	21—Call rejected	41—Temporary failure
413 Request Entity Too Big	21—Call rejected	28—Invalid number format
414 Request URI Too Large	21—Call rejected	28—Invalid number format
420 Bad Extension	21—Call rejected	28—Invalid number format
484 Address Incomplete	21—Call rejected	28—Invalid number format
408 Request Timeout	21—Call rejected	41—Temporary failure
480 Temporarily unavailable	21—Call rejected	41—Temporary failure
486 Busy Here	21—Call rejected	17—User Busy
401 Unauthorized	21—Call rejected	32—Normal unspecified
407 Proxy Authentication Required	21—Call rejected	32—Normal unspecified
All other 4xx	21—Call rejected	16—Normal unspecified
502 Bad Gateway	38—Network out of order	28—Invalid number format
505 Bad Version	38—Network out of order	88—Incompatible destination

SIP Status Category/ Event	SIP CDR Disconnect Cause	H.323 Disconnect Cause Value (Q.850)
All other 5xx	38—Network out of order	16—Normal unspecified
600 Busy Everywhere	31—Normal unspecified	41—Temporary failure
603 Decline	31—Normal unspecified	31—Normal unspecified
604 Does Not Exist Anywhere	31—Normal unspecified	3—No route to destination
All other 6xx	31—Normal unspecified	31—Normal unspecified

H.323 Events and Errors

The Q.850 cause code value is recorded for the disconnect cause in the CDR for the H.323 call leg if the Q.850 cause is received. H.323 recommendations state that either Q.850 Cause of RelCompReason is mandatory for the RELEASE COMPLETE; the Cause information element (IE) is optional everywhere. The Cause IE and the ReleaseCompleteReason (part of the release complete message) are mutually exclusive.

If a Q.850 cause code is not received, the OCSBC records a Q.850 cause value mapped from the received ReleaseCompleteReason as defined in the table below.

The entries in this table are determined by the [SIP Status to H.323 Disconnect Reason Mapping](#).

H.323 ReleaseCompleteReason	H.323 CDR Disconnect Cause	SIP Status	SIP CDR Disconnect Cause
No Bandwidth	34—No channel/circuit available	480 Temporarily Unavailable	21—Call rejected
Gatekeeper Resource	47—Resource unavailable	404 Not Found	21—Call rejected
Unreachable Destination	3—No route to destination	404 Not Found	21—Call rejected
Destination Rejected	31—Normal unspecified	603 Decline	31—Normal unspecified
Invalid Revision	88—Incompatible destination	505 Version Not Supported	38—Network out of order
No Permission	111—Interworking unspecified	401 Unauthorized	21—Call rejected
Unreachable Gatekeeper	38—Network out of order	503 Service Unavailable	38—Network out of order
Gateway Resource	42—Switching equipment congestion	480 Temporarily unavailable	21—Call rejected
Bad Format Request	28—Invalid number format	400 Bad request	21—Call rejected
Adaptive Busy	41—Temporary failure	486 Busy Here	21—Call rejected
In Conference	17—User busy	486 Busy Here	21—Call rejected
Undefined Reason	16—Normal unspecified	500 Internal Server Error	38—Network out of order
Called Party Not Registered	20—Subscriber absent	404 Not Found	21—Call rejected

H.323 ReleaseCompleteReason	H.323 CDR Disconnect Cause	SIP Status	SIP CDR Disconnect Cause
Caller Not Registered	31—Normal call clearing		
New Connection Needed	47—Resource Unavailable	401 Unauthorized	21—Call rejected

H.225 RAS Errors

For calls that are rejected because of H.225 RAS, there is no CDR generated for the H.323 call leg as no Setup message is generated. The OCSBC maps RAS errors to SIP Status as specified in the table below. The SIP CDR disconnect cause values are the same as the CSPA disconnect cause values already mentioned and defined.

The entries in this table are determined by the [SIP Status to H.323 RAS Error Mapping](#).

H.225 RAS Error	SIP Status	SIP CDR Disconnect Cause
Called Party Not Registered	404 Not Found	21—Call Rejected
Invalid Permission	401 Unauthorized	21—Call Rejected
Request Denied	503 Service Unavailable	38—Network out of order
Undefined	500 Internal Server Error	38—Network out of order
Caller Not Registered	401 Unauthorized	21—Call Rejected
Route Call to Gatekeeper	305 Use Proxy	23—Redirection to new destination
Invalid Endpoint ID	500 Internal Server Error	38—Network out of order
Resource Unavailable	503 Service Unavailable	38—Network out of order
Security Denial	401 Unauthorized	21—Call Rejected
QoS Control Not Supported	501 Not Implemented	38—Network out of order
Incomplete Address	484 Address Incomplete	21—Call Rejected
Route Call to SCN	302 Moved Temporarily	2—Redirection
Aliases Inconsistent	485 Ambiguous	21—Call Rejected
Not Currently Registered	401 Unauthorized	21—Call Rejected

SIP Call Tear Down Due to Media Guard Timer Expiration

When a SIP call is torn down by the OCSBC due to media timers expiring, the following standard and VS attributes and their corresponding values will appear in the CDR stop message:

CDR Output

The following CDR AVPs must be observed in the same CDR.

```
Acct-Terminate-Cause = Idle-Timeout
h323-disconnect-cause = "6"
Acme-Disconnect-Initiator = 3
```

Explanation

- Acct-Terminate-Cause = Idle-Timeout: This standard RADIUS AVP indicates the call was ended due to a timer expiring.
- h323-disconnect-cause = "6": This VSA AVP indicates the call was ended due to a timeout.
- Acme-Disconnect-Initiator = 3: This VSA AVP indicates the call disconnect was initiated internally from the OCSBC, and not from an endpoint or due to an unknown reason.

2

Configuring Accounting

Overview

This chapter provides you with information about configuring RADIUS accounting on your OCSBC including these essential configurations and specialized features:

- Accounting for SIP and H.323
- Local CDR storage on the OCSBC, including CSV file format settings-
- The ability to send CDRs via FTP to a RADIUS sever
- Per-realm accounting control
- Configurable intermediate period
- RADIUS CDR redundancy
- RADIUS CDR content control

Accounting for SIP and H.323

This section explains SIP and H.323 accounting using the RADIUS Accounting System (RAS).

For accounting purposes, the OCSBC uses RADIUS to send accounting messages. These messages are transmitted to one of a predefined list of accounting servers using a predefined forwarding strategy. RAS provides a mechanism for temporarily storing session initiation and completion statistics and for delivering these statistics to accounting servers located elsewhere in the network.

Call Detail Records

The OCSBC supports CDRs through RADIUS reporting with additional VSAs to include information that is not available with the standard RADIUS session information. CDRs provide billing information on sessions traversed through a system, as well as troubleshooting information, fraud detection, fault diagnostics, and service monitoring.

CDRs can contain information about recent system usage such as the identities of sources (points of origin), the identities of destinations (endpoints), the duration of each call, the amount billed for each call, the total usage time in the billing period, the total free time remaining in the billing period, and the running total charged during the billing period. VSAs are defined by vendors of remote access servers in order to customize how RADIUS works on their servers.

RAS Overview

The RAS acts as a RADIUS client. It provides a mechanism for generating accounting information in CDRs. The CDRs are transmitted to a RADIUS server in UDP datagrams, using RADIUS Accounting Request messages.

The RAS receives RADIUS accounting messages when different events occur. The event and CDR event trigger list information determines which RADIUS messages, if any, are included, as well as which RADIUS attributes are included. The library adds RADIUS messages to the waiting queue only when the message is ready to be sent. The SIP proxy needs to populate the CDR as session information becomes available so, by the time the session ends, it contains the information necessary to generate all of the messages.

The RADIUS accounting client process manages its queue and a list of servers. The servers each have a UDP connection and manage their own pending message queues. Changes in the state of the server connection might cause interaction with the client process waiting queue.

When RADIUS messages are added to the RAS waiting queue, the RAS sends them to a server based on strategy. If the RAS is configured to transmit all the messages when the session ends, all the messages are sent to the same server. Each session continues logging messages according to the event logging scheme in effect when the session began (for example, when the CDR was created).

The RAS notifies the RADIUS server with Accounting-On/Off messages when the RAS's entry for that server is enabled/disabled. The response to the Accounting-On message is the RAS's first determination of RTT, and serves as notification that the server is reachable. Until the Accounting-On response is received, the server cannot send other messages.

RADIUS Accounting Client

The RADIUS accounting client process has a local socket at which it accepts RADIUS messages. RADIUS messages received on the local socket are added to the waiting queue for transmission to a RADIUS server. The waiting queue is a first-in, first-out (FIFO) queue.

The RADIUS accounting client process sends messages to a server queue based on the configuration (servers configured/enable/connected, as well as the strategy). Messages that return from a server (due to server failure/disabling) are first in the FIFO queue.

The RADIUS accounting client process interfaces with the RADIUS accounting servers using the RADIUS protocol with the VSAs outlined above.

The RADIUS server collects a variety of information that can be used for accounting and for reporting on network activity. The RADIUS client sends information to designated RADIUS servers when the user logs on and logs off. The RADIUS client might send additional usage information on a periodic basis while the session is in progress. The requests sent by the client to the server to record logon/logoff and usage information are generally called accounting requests.

RADIUS accounting permits a RADIUS server to track when users commence and terminate their connections. Typical accounting information includes the following:

- Full user name
- RAS identification name or IP address
- RAS port number
- Time connection started

When a client is configured to use RADIUS accounting, it generates an Accounting Start packet describing the type of service being delivered and the user it is being delivered to at the start of service delivery. It sends that packet to the RADIUS Accounting server, which sends back an acknowledgement that the packet has been received. At the end of service delivery, the client generates an Accounting Stop packet describing the type of service that was delivered and, optionally, statistics such as elapsed time, input and output octets, or input and output packets. It sends that packet to the RADIUS Accounting server, which sends back an acknowledgement that the packet has been received. The Accounting-Request (whether for Start or Stop) is submitted to the RADIUS accounting server through the network.

Transactions between the client and RADIUS accounting server are authenticated through the use of a shared secret, which is never sent over the network.

Session Accounting

The RAS client can record SIP, H.323, and IWF session activity based on configuration and a CDR. The CDR determines which messages are generated and determines the RADIUS attributes included in the messages. The RAS client must be capable of sending CDRs to any number of RADIUS accounting servers, using the defined hunt, failover, round robin, fewest pending, or fastest server strategies.

The establishment, failed establishment, change, or removal of a session can trigger RADIUS Accounting Request messages. The RAS might also send notification of its status (enabled/disabled). RADIUS Accounting Request messages include the following:

- Start—Session has started.
- Interim-Update—Session parameters have changed.
- Stop—Session has ended.
- Accounting-On—Creation of a new RADIUS client.
- Accounting-Off—RADIUS client has shut down.

Each session might generate Start, Interim-Update, and Stop messages based on the local configuration when the session is initiated. Each Start message tells the RADIUS server that a session has started. Each Interim-Update message changes the session parameters, and may report the session characteristics for the session to that point. Each Stop message informs the RADIUS server that a session has ended and reports session characteristics.

The RAS has the ability to transmit all RADIUS messages related to a session at the end of the session, regardless of which messages are generated and when they are generated. Some customers might choose this option to reduce the likelihood of the RADIUS messages being logged to different servers, or in different log files on the same server.

The RAS always generates a RADIUS Stop message when the session ends, regardless of the session termination cause. The termination cause and the session characteristics are reported.

Interim RADIUS Records for Recursive Attempts

When the OCSBC routes calls, it performs local policy look-ups that can return several next hops, ordered by preference. This can also happen as a result of an LRT lookup, an ENUM query response, or SIP redirect. To set up sessions, the OCSBC uses—in ordered preference—and recurses through the list if it encounters failures.

You can configure SIP accounting to send RADIUS Interim records when the OCSBC encounters these failures. The interim message contains: the destination IP address, the disconnect reason, a timestamp for the failure, and the number that was called. This feature is enabled by setting the generate-interim parameter to **unsuccessful-attempt**. Please refer to Appendix B to view the format of an unsuccessful-attempt interim record.

RADIUS Messages

The following table identifies the relationship between the signaling elements and the RADIUS attributes included in Accounting Request messages to the RADIUS server.

RADIUS Attribute	Data Element	Message
NAS IP-Address	IP address of the SIP proxy or the H.323 stack's call signal address.	Start, Interim-Update, Stop, On, Off
NAS Port	SIP proxy port or the H.323 stack's call signaling RAS port.	Start, Interim-Update, Stop, On, Off
NAS Identifier	Value, if any, set in the optional NAS-ID field for the accounting server that you configure as part of the accounting configuration. This identifier sets the value that the remote server (the accounting server) uses to identify the OCSBC so that RADIUS messages can be transmitted. The remote server to which the accounting configuration will send messages uses at least one of two pieces of information for identification: NAS IP address: always included in the accounting message NAS identifier: configured in the NAS-ID parameter of the accounting server; if configured, the NAS identifier is sent to the remote server This attribute only appears if a value is configured in the NAS-ID field.	Start, Interim-Update, Stop, On, Off
Acct-Session-ID	Either the Call-ID field value of the SIP INVITE message, the callIdentifier of the H.323 message, or RADIUS client information.	Start, Interim-Update, Stop, On, Off
Called Station ID	To field value of the SIP INVITE message (a type of message used to initiate a session) or the calledPartyNumber of the H.323 message.	Start, Interim-Update, Stop

RADIUS Attribute	Data Element	Message
Calling Station ID	From field value of the SIP INVITE message or the callingPartyNumber of the H.323 message.	Start, Interim-Update, Stop
Acct-Terminate-Cause	Reason for session ending (refer to Session Termination session).	Stop, Off
Acct-Session-Time	Length of session (time in seconds, or milliseconds if so configured).	Interim-Update, Stop, Off

Session Termination

Sessions are terminated for reasons that include normal termination, signaling failure, timeout, or network problems. The following table maps RADIUS accounting termination cause codes to network events.

RADIUS Termination Cause	Event	Message
User request	SIP BYE message or H.323	Stop
User error	SIP signaling failed to establish session (accompanied by disconnect cause)	Stop
NAS request	RADIUS server disabled	Off

ACLI Instructions and Examples

This section tells you how to access and set parameters for RADIUS accounting support. To use the OCSBC with external RADIUS (accounting) servers to generate CDRs and provide billing services requires, you need to configure account configuration and account server list.

Accessing the Accounting and Accounting Servers Configuration

To configure the account configuration and account servers:

1. In Superuser mode, navigate to the **account-config** parameter.

```
ORACLE# configure terminal
ORACLE(configure)# session-router
ORACLE(session-router)# account-config
ORACLE(account-config)#
```

2. To configure account server parameters (a subset of the account configuration parameters), type **account-servers** and press Enter. The system prompt changes to let you know that you can begin configuring individual parameters.

```
ORACLE(account-config)# account-servers
ORACLE(account-server)#
```

Setting Up the Account Configuration

You set the account configuration parameters to indicate where you want accounting messages sent, when accounting messages you want them sent, and the strategy you want used to select account servers.

To configure the account configuration:

1. **hostname**—Defaults to and must remain localhost.
2. **port**—Retain the default value of 1813 or enter the number of the UDP port associated with the OCSBC from which RADIUS messages are sent.
 - minimum: 1025
 - maximum: 65535
3. **strategy**—Indicate the strategy you want used to select the accounting servers to which the OCSBC will send its accounting messages. The following table lists the available strategies:
 - **hunt**—Selects accounting servers in the order in which they are listed. If the first accounting server is online, working, and has not exceeded any of the defined constraints, all traffic is sent to it. Otherwise the second accounting server is selected. If the first and second accounting servers are offline or exceed any defined constraints, the third accounting server is selected. And so on through the entire list of configured servers.
 - **failover**—Uses the first server in the list of predefined accounting servers until a failure is received from that server. Once a failure is received, it moves to the second accounting server in the list until a failure is received. And so on through the entire list of configured servers.
 - **round robin**—Selects each accounting server in order, distributing the selection of each accounting server evenly over time.
 - **fastest round trip time**—Selects the accounting server that has the fastest round trip time (RTT) observed during transactions with the servers (sending a record and receiving an ACK).
 - **fewest pending**—Selects the accounting server that has the fewest number of unacknowledged accounting messages (that are in transit to the OCSBC).
4. **state**—Retain the default value **enabled** if you want the account configuration active on the system. Enter **disabled** if you do not want the account configuration active on the system.
5. **max-msg-delay**—Retain the default value of **60** seconds or indicate the length of time in seconds that you want the OCSBC to continue trying to send each accounting message. During this delay, the OCSBC can hold a generic queue of 4096 messages.
 - Minimum: zero (0)
 - Maximum: 4294967295
6. **max-wait-failover**—Retain the default value of **100** messages or indicate the maximum number of accounting messages the OCSBC can store its message waiting queue for a specific accounting server, before it is considered a failover situation.

Once this value is exceeded, the OCSBC attempts to send its accounting messages, including its pending messages, to the next accounting server in its configured list.

- Minimum: one (1) message
 - Maximum: 4096 messages
7. **trans-at-close**—Retain the default value of **disabled** if you do not want to defer the transmission of message information to the close of a session. Enter **enabled** if you want to defer message transmission.
- **disabled**—The OCSBC transmits accounting information at the start of a session (Start), during the session (Interim), and at the close of a session (Stop). The transmitted accounting information for a single session might span a period of hours and be spread out among different storage files.
 - **enabled**—Limits the number of files on the OCSBC used to store the accounting message information for one session. It is easiest to store the accounting information from a single session in a single storage file.
8. **generate-start**—Retain the default value **ok** if you want the RADIUS Start message to be generated once the OCSBC receives an OK message in response to an INVITE.

Other options include:

- **Invite**—RADIUS Start message should be generated once the OCSBC receives a SIP session INVITE.
 - **None**—RADIUS Start message is not generated.
 - **""**—When two quotation marks are entered next to each other (empty), behavior is identical to none value.
9. **generate-interim**—Retain the default value **reinvite response** to cause the OCSBC to transmit a RADIUS Interim message. (A RADIUS Interim message indicates to the accounting server that the SIP session parameters have changed.)

You can select none, one, or more than one of the following values:

- **ok**—RADIUS Start message is generated when the OCSBC receives an OK message in response to an INVITE.
- **reinvite**—RADIUS Interim message is generated when the OCSBC receives a SIP session reINVITE message.
- **reinvite response (default)**—RADIUS Interim message is generated when the OCSBC receives a SIP session reINVITE and responds to it (for example, session connection or failure).
- **reinvite cancel**—RADIUS Interim message is generated when the OCSBC receives a SIP session reINVITE, and the Reinvite is cancelled before the OCSBC responds to it.
- **unsuccessful-attempt**—RADIUS Interim message is generated when a SIP session set-up attempt from a preference-ordered list of next-hop destinations is unsuccessful. This can happen when a local policy lookup, LRT lookup, ENUM query response, or SIP redirect returns a preference-ordered list of next-hop destinations. The interim message contains: the destination IP address, the disconnect reason, a timestamp for the failure, and the number that was called.

- 10. account-server**—Create the account server list to store accounting server information for the account configuration. Each account server can hold 100 accounting messages. See the next section for step-by-step instructions.

Account server entries are specific to the account configuration. They cannot be viewed or accessed for editing outside of the account configuration.

 **Note:**

RADIUS will not work if you do not enter one or more servers in a list.

Setting Up Accounting Servers

You must establish the list of servers to which the OCSBC can send accounting messages.

- 1. hostname**—Host associated with the account server as an IP address.
- 2. port**—Retain the default 1813 or enter the number of the UDP port associated with the account server to which RADIUS messages are sent.
 - minimum: 1025
 - maximum: 65535
- 3. state**—Retain the default enabled to enable the account servers on the system or enter disabled to disable them.
- 4. min-round-trip**—Retain the default 250 milliseconds or indicate the minimum round trip time of an accounting message.
 - minimum: 10 milliseconds
 - maximum: 5000 milliseconds

A round trip consists of the following:

- The OCSBC sends an accounting message to the account server.
- The account server processes this message and responds back to the OCSBC.

If the fastest RTT is the strategy for the account configuration, the value you enter here can be used to determine an order of preference (if all the configured account servers are responding in less than their minimum RTT).

- 5. max-inactivity**—Retain the default 60 seconds or indicate the length of time in seconds that you want the OCSBC with pending accounting messages to wait when it has not received a valid response from the target account server.
 - minimum: 1 second
 - maximum: 300 seconds

Once this timer value is exceeded, the OCSBC marks the unresponsive account server as disabled in its failover scheme. When a server connection is marked as inactive, the OCSBC attempts to restart the connection and transfers pending messages to another queue for transmission. RADIUS messages might be moved between different account servers as servers become inactive or disabled.

6. **restart-delay**—Retain the default 30 seconds or indicate the length of time in seconds you want the OCSBC to wait before resending messages to a disabled account server.
 - minimum: 1 second
 - maximum: 300 seconds
7. **bundle-vs-a**—Retain the default enabled if you want the account server to bundle the VSAs within RADIUS accounting messages. Enter disabled if you do not want the VSAs to be bundled. (Bundling means including multiple VSAs within the vendor value portion of the message.)

In a bundled accounting message, the RADIUS message type is vendor-specific, the length is determined for each individual message, and the vendor portion begins with a 4-byte identifier, and includes multiple vendor type, vendor length, and vendor value attributes.

8. **secret**—Enter the secret passed from the account server to the client in text format. Transactions between the client and the RADIUS server are authenticated by the shared secret; which is determined by the source IPv4 address of the received packet.
9. **NAS-ID**—Optional. Enter the NAS ID in text format (FQDN allowed). The account server uses this value to identify the OCSBC for the transmittal of accounting messages.

The remote server to which the account configuration sends messages uses at least one of two potential pieces of information for purposes of identification. The OCSBC accounting messages always includes in the first of these:

- Network Access Server (NAS) IP address (the IP address of the OCSBC's SIP proxy)
- NAS ID (the second piece of information) provided by this value. If you enter a value here, the NAS ID is sent to the remote server.

If you have more than one OCSBC pointing to the same account server, the NAS ID can be used to identify which OCSBC generated the record.

SIP CDR Stop Time

You can set up your global SIP configuration so the disconnect time reflected in a RADIUS CDR is the time when the OCSBC receives a BYE. Enabling this parameter also means the disconnect time is defined when the OCSBC sends a BYE to the UAS and UAC. Otherwise, the the CDR's value is based on when the 200 OK confirms the BYE.

The applicable RADIUS CDR in this case is the standard RADIUS attribute Acct-Session-Time, number 46.

ACL I Instructions and Examples

To enable definition of the disconnect time based on the BYE:

1. Access the **sip-config** configuration element.

```
ORACLE# configure terminal
ORACLE(configure)# session-router
```



```
ORACLE(session-router)# sip-config
ORACLE(sip-config)#
```

2. Select the **sip-config** object to edit.

```
ORACLE(sip-config)# select
```

```
ORACLE(sip-config)#
```

3. **set-disconnect-time-on-bye**—Set this parameter to **enabled** if you want to use the BYE message as the defining factor for the disconnect time. This parameter is disabled by **default**.
4. Type **done** to save your configuration.

Set Acct-session-time attribute to milliseconds

Some accounting features require greater precision. The attribute **acct-session-time** can be configured to be in milliseconds.

The RADIUS attribute **acct-session-time** uses seconds as its default. You can set this to a millisecond granularity in the **account-config** configuration element using the option **millisecond-duration**. This option setting is required for the RADIUS CDR display, Diameter RF accounting and locally-generated CDR comma separated value (CSV) files behaviors.



Note:

Changing to millisecond granularity violates RFC 2866.

Configure acct-session-time for millisecond granularity

Set the option for millisecond granularity for the **acct-session-time** attribute.

1. Access the **account-config** configuration element.

```
ORACLE# configure terminal
ORACLE(configure)# session-router
ORACLE(session-router)# account-config
ORACLE(account-config)#
```

2. Type **select** to begin configuring this object.
3. **options**—Set the **options** parameter by typing **+options**, a Space, the option name **millisecond-duration** and then press Enter.
4. Type **done** to save your configuration.

Per Realm Accounting Control

You can enable or disable accounting control for specific realms by setting one parameter. This feature is enabled by default.

The OCSBC's SIP and H.323 tasks check whether this parameter is set to enabled or disabled, and sends record on that basis.

ACLI Instructions

To configure per realm accounting:

1. Access the **realm-config** configuration element.

```
ORACLE# configure terminal
ORACLE(configure)# media-manager
ORACLE(media-manager)# realm-config
ORACLE(realm-config)#
```

2. Select the **realm-config** object to edit.

```
ORACLE(realm-config)# select
identifier:
1: realm01 left-left:0 0.0.0.0

selection: 1
ORACLE(realm-config)#
```

3. **accounting-enable**—Either leave this parameter set to enabled (default) to generate CDRs for this realm, or change it to disabled.
4. Type **done** to save your configuration.

Configurable Intermediate Period

You can set how often the OCSBC generates periodic interim records for H.323 and for SIP.

- H.323—The periodic timer (set to the value you specify in the accounting configuration) is dynamically created when the OCSBC receives a Connect message and an H.323 call answer method is invoked. The OCSBC deletes the timer when the H.323 session is terminated.
- SIP—The periodic timer (set to the value you specify in the accounting configuration) is dynamically created when the OCSBC receives an initial INVITE message. The OCSBC deletes the timer when the session is terminated. To set the timer for periodic interim records:

1. In Superuser mode, type **configure terminal** and press Enter.

```
ORACLE# configure terminal
```

2. Type **session-router** and press Enter.

```
ORACLE(configure)# session-router
```

3. Type **account-config** and press Enter.

```
ORACLE(session-router)# account-config
```

4. **intermediate-period**—Enter amount of time in seconds between generating periodic interim records during a SIP or H.323 call. This parameter defaults to zero, which is not a valid value.
5. Save and activate your configuration.

Media Stop Time VSA in CDRs

An accurate portrayal of a call's media stop time is important for billing accuracy. Calls are often terminated well after the media has stopped flowing for such reasons as network or equipment peculiarities.

Media Stop Time VSAs

To record the actual media stop time, the Oracle Communications Session Border Controller writes the following four VSAs in CDR Stop Records:

```
Acme-Flow-Calling-Media-Stop-Time_FS1
Acme-Flow-Called-Media-Stop-Time_FS1
Acme-Flow-Calling-Media-Stop-Time_FS2
Acme-Flow-Called-Media-Stop-Time_FS2
```

These VSAs correspond to:

- calling side's media stop time - stream 1
- called side's media stop time - stream 1
- calling side's media stop time - stream 2
- called side's media stop time - stream 2

Media Stop Time Calculation

The granularity of the time at which the Oracle Communications Session Border Controller's checks for media stream idleness, the actual media stop time, as inserted into a CDR is accurate to between 0 and +10 seconds.

In the following diagram, media idleness monitoring is checked in 10 second time frames. Labeled time measurements are as follows:

T_c —Time between most recent idleness sample end and end-of-call time

T_m —2 complete idleness windows

T_e —Time into the idleness window in which the call's media stopped. This is also the error amount of the recorded media stop time.

T_i —The actual time between the end of media and the end of call.

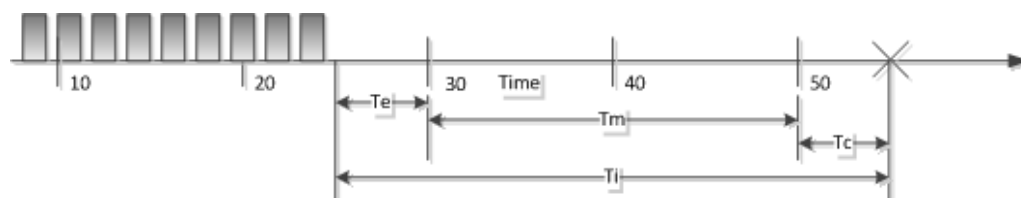

Tm and Tc are known. The Oracle Communications Session Border Controller also knows that the media ended between 20 and 30 seconds, but the actual time, 10- Te into the frame is unknown. Thus, the time recorded in the CDR is quantized up to the end of the media stop frame at 30 seconds. This time, as written to the CDR, must be interpreted with possible error of $0 \leq T_e < 10$ seconds.

HA Caveat

When a switchover occurs between media stop time and end of call, the media stop time written to the CDR is the failover time.

RADIUS CDR Content Control

The OCSBC's RADIUS support has been enhanced so that you can limit the size of RADIUS CDRs. The OCSBC's RADIUS accounting provides a detailed set of records that can contain, for example, multiple media flow descriptions for forked calls that can contain multiple sets of media and QoS attributes. While the level of detail might be required for some networks, in others the large CDRs generated to reflect that level of granularity can cause issues for the application receiving the records.

You can use the following enhancements to control the size of the RADIUS CDRs your OCSBC produces:

- Duplicate RADIUS attribute prevention—Using this feature, you can configure the OCSBC to send only one set of RADIUS attributes in CDR for a forked call. (When a forked SIP INVITE contains media information, media and QoS attributes can potentially be duplicated.)
- RADIUS attribute selection—You can set a list of the Oracle VSAs you want included in a RADIUS CDR, and the OCSBC will exclude the others from the record; standard attributes are always included. You specify attributes using their unique identifier in a comma-delimited list, and you can list them in any order. However, entering an invalid range disables this feature. The OCSBC excludes attributes from the records in which they are already defined. If an attributes only appears in a Stop record, then it will be deleted from Stop records.

The configuration provides a mechanism to make entries flexible and easy.

ACLI Instructions and Examples

You enable these enhancements using two parameters in the accounting configuration.

Accessing the Accounting Configuration

To access the accounting configuration:

1. In Superuser mode, type **configure terminal** and press Enter.

```
ORACLE# configure terminal
```

2. Type **session-router** and press Enter.

```
ORACLE(configure)# session-router
```

3. Type **account-config** and press Enter.

```
ORACLE(session-router)# account-config
```

From this point, you can reach the individual parameters for duplicate RADIUS attribute prevention and for RADIUS attribute selection.

Preventing Duplicate RADIUS Attributes

To enable duplicate RADIUS attribute prevention:

1. **prevent-duplicate-attrs**—Enable this parameter to prevent the OCSBC from duplicating attributes in the accounting records it generates. This duplication can be caused, for example, by multiple media sessions within the context of a call. Retaining the default (disabled) allows the OCSBC to include duplicate attributes in RADIUS, Diameter and Local accounting records. This can result in attribute placement and counts that are less consistent.

```
ORACLE(account-config)# prevent-duplicate-attrs enabled
```

2. Save and activate your configuration.

RADIUS Attribute Selection

You enter the list of VSAs that you want included as a comma-delimited list. There are special entry types you can use in the comma-delimited list to set ranges and make entries easier:

- X- — Where X is a VSA identifier, the OCSBC will include all attributes with an identifier equal to or greater than X.
- -X — Where X is a VSA identifier, the OCSBC will include all attributes with an identifier equal to or less than X.
- - — Use the minus sign (-) alone when you want to turn off attribute selection, including all VSAs in the CDR.

To enter a list of RADIUS attributes to include in a CDR:

1. **vsa-id-range**—Enter a comma-delimited list that represents the VSA you want to appear in the RADIUS CDR. There is no default for this parameter.

Do not use <Spaces> when typing in your comma-delimited list.

```
ORACLE(account-config)# vsa-id-range -5,7,10-
```

This entry specifies that CDRs contain VSA with identifiers equal to and less than 5, VSA 7, and VSAs with identifiers equal to and greater than 10.

Limit this list to accounting VSAs. For example, VSA 254 is an authentication VSA, so it should not be included in the range. The system generates validate-config errors if your range includes VSAs that are not accounting VSAs.

2. Save and activate your configuration.

Custom RADIUS CDR VSAs for SIP

This section describes these additions to the OCSBC's RADIUS accounting capabilities for customizing your call detail records (CDRs):

- Generating CDRs with call detail information from a SIP message—The OCSBC reserves a set of vender-specific attributes (VSAs) and then populates them according to your header manipulation (HMR) configuration
- Generating CDRs with trunk group information—You can enable your OCSBC to provide terminating trunk-group and trunk-context data even when the OCSBC is not performing trunk-group routing.

Both support using the CSV file for RADIUS records, which you can either save locally or push to a defined FTP server.

About User-Defined VSAs for SIP Calls

The OCSBC reserves VSAs 200-229 for you to define for use with SIP calls. These VSAs should never be used for other purposes, and their use should never conflict with the need to add new VSAs in the future. Because this leaves a significant number of VSAs unused, there is still ample space for any new VSAs that might be required.

Since RADIUS START records are created on session initiation, their content cannot be updated. However, the content for INTERIM and STOP records can be.

To configure user-defined VSAs for a SIP call, you use HMR. For example, when you set up HMR correctly, the OCSBC reports originating or terminating country codes in CDRs in whatever format they appear in the SIP username field. The HMR rules you configure uses the SIP header name P-Acme-VSA, adding it to the SIP header from any part of the SIP message. Then the OCSBC searches for the P-Acme-VSA header, generates a VSA for it, and then includes that VSA in the CDR for the call.

You can include multiple custom VSAs per CDR by adding the corresponding number of rules; in essence, you add in the header as many times as required.

HMR Adaptations

The following HMR element rule types support user-defined VSA for SIP calls:

- **uri-user-only**—The **uri-user-only** element rule type represents the URI username without the URI user parameters. You can perform these actions for the **uri-user-only** type: store, replaces, delete, and add. This means, for example, that you can add a username string to SIP or TEL URI without having any impact on other parameters.
- **uri-phone-number-only**—The **uri-phone-number-only** applies when all rules are met. It refers to the user part of the SIP/TEL URI without the user parameters when the user qualifies for the BNF shown here:

```
uri-phone-number-only    =  [+]* (phone-digit / dtmf-digit / pause-
                             character)
phone-digit               =  DIGIT / visual-separator
DIGIT                    =  "0" / "1" / "2" / "3" / "4" / "5" /
                             "6" / "7" / "8" / "9"
visual-separator         =  "-" / "." / "(" / ")"
```

```
dtnf-digit          =  "*" / "#" / "A" / "B" / "C" / "D"  
pause-character    =  "p" / "w"
```

Once the URI user part qualifies as a uri-phone-number-only based on this BNF, the OCSBC ignores the visual separators when comparing it against a match value. Furthermore, the OCSBC performs on or using the uri-phone-number-only after the excluding the visual separators.

But anew value being added as a uri-phone-number-only or replacing a uri-phone-number-only does not have to match the BNF noted above. That is, you can use the **uri-phone-number-only** type knowing that:

- The action only occurs if the URI username matches the BNF defined here.
- Even so, you can also replace the uri-phone-number-only with one that does not match—using the same rule.

HMR String Variable

HMR supports the use of a string variable that you can use to populate headers and elements. You set this value in the **hmr-string** parameter for a realm, SIP session agent, or SIP interface. Then, you reference it as the \$HMR_STRING variable.

When a message arrives, the OCSBC matches the string you provision to the closest session agent, realm, or SIP interface. The precedence for matching is in this order: session agent, realm, and then SIP interface. For example, the OCSBC populates messages matching a session agent using the \$HMR_STRING variable, but it leaves the value empty for session agents that do not match.

You can use the string variable, for instance, for values specific to realms and session agents such as country code values when the regular expression pattern used to match a country code fails to do so.

ACLI Instructions and Examples User-Defined VSAs

This section shows you how to configure user-defined VSAs for SIP calls. It also contains subsections with configuration examples so you can see how this feature is put to use.

This section also shows you two configuration examples for this feature.

To create a header manipulation rule that generates user-defined VSAs for SIP calls:

1. In Superuser mode, type **configure terminal** and press Enter.

```
ORACLE# configure terminal  
ORACLE(configure)#
```

2. Type **session-router** and press Enter.

```
ORACLE(configure)# session-router  
ORACLE(session-router)#
```

3. Type **sip-manipulation** and press Enter.

```
ORACLE(session-router)# sip-manipulation
ORACLE(sip-manipulation)#
```

4. Type **header-rules** and press Enter.

```
ORACLE(session-router)# header-rules
ORACLE(sip-header-rules)#
```

5. **name**—Enter a meaningful name for the header rule you are creating. For example, if you want to add VSA 200 to your CDRs for SIP calls, you might name your rule **generateVSA200**. There is no default for this parameter, and it is required.
6. **header-name**—Set this parameter to P-Acme-VSA so the OCSBC will add this accounting information to CDRs for the call.
7. **action**—Set this parameter to **add**.
8. **new-value**—Enter the regular expression value for the new value you want to add. For example, to add VSA 200 that contains the value from the SIP From header, you would enter **200:+\$storeFrom.\$0**.
9. Save and activate your configuration.

The first example shows you how to generate custom VSA for the To and From headers in SIP messages.

- VSA 200 contains the header value from the SIP From header.
- VSA 220 contains the header value from the SIP To header.

```
sip-manipulation
  namecustom                               VSA1
  description
  header-rule
    name                                   storeFrom
    header-name                             from
    action                                   store
    comparison-type                         pattern-rule
    match-value                             .*
    msg-type                                 request
    new-value
    methods                                 INVITE
  header-rule
    name                                   storeTo
    header-name                             to
    action                                   store
    comparison-type                         pattern-rule
    match-value                             .*
    msg-type                                 request
    new-value
    methods                                 INVITE
  header-rule
    name                                   generateVSA200
    header-name                             P-Acme-VSA
    action                                   add
```



```

                                comparison-type      case-sensitive
                                match-value
msg-type                          any
                                new-value           200:+$storeFrom.$0
                                methods            INVITE
                                header-rule
                                name                generateVSA220
                                header-name        P-Acme-VSA
                                action             add
                                comparison-type    case-sensitive
                                match-value
                                msg-type          any
                                new-value         220:+$storeTo.$0
                                methods            INVITE
  
```

The second example shows you how to configure HMR to generate VSA 225, which contains the customer P_From header when it is present. When that header is not present, the rule instructs the OCSBC to include the header value from the SIP From header for VSA 225.

```

sip-manipulation
  name                          customVSA1
  description
  header-rule
    name                          storePfrom
    header-name                    P_From
    action                          store
    comparison-type                pattern-rule
    match-value                    .*
    msg-type                        request
    new-value
    methods                          INVITE
  header-rule
    name                          storeFrom
    header-name                    from
    action                          store
    comparison-type                pattern-rule
    match-value                    .*
    msg-type                        request
    new-value
  methods                          INVITE
  header-rule
    name                          generateVSA225_1
    header-name                    P-Acme-VSA
    action                          add
    comparison-type                case-sensitive
    match-value
    msg-type                        request
    new-value                      225:+$storeFrom.$0
    methods                          INVITE
  header-rule
    name                          generateVSA225_2
    header-name                    P-Acme-VSA
    action                          manipulate
    comparison-type                pattern-rule
  
```

```

        match-value          $storePfrom
        msg-type             request
        new-value
        methods              INVITE
element-rule
        name                 one
        parameter-name
        type                 header-value
        action               delete-element
        match-val-type       any
        comparison-type      pattern-rule
        match-value          ^225.*
        new-value
element-rule
        name                 two
        parameter-name
        type                 header-value
        action               add
        match-val-type       any
        comparison-type      case-sensitive
        match-value
        new-value
225:+$storePfrom.$0

```

ACLI Instructions and Examples String Variable

To use the HMR string variable, you set the **hmr-string** value in the SIP session agent, realm, or SIP interface where you want the feature applied. The following sample shows you how to configure the **hmr-string** parameter for SIP session agent.

1. In Superuser mode, type **configure terminal** and press Enter.

```

ORACLE# configure terminal
ORACLE(configure)#

```

2. Type **session-router** and press Enter.

```

ORACLE(configure)# session-router
ORACLE(session-router)#

```

3. Type **session-agent** and press Enter.

```

ORACLE(session-router)# session-agent
ORACLE(session-agent)#

```

If you are adding this feature to an existing configuration, you need to select the configuration (using the ACLI **select** command) before making your changes.

4. **manipulation-string**—Enter a value that references the \$HMR_STRING variable that will be used to populate SIP headers and elements using HMR. There is no default value for this parameter.
5. Save and activate your configuration.

Trunk-Group VSA Generation

You can force the OCSBC to generate VSAs related to trunk groups even when you are not using the trunk group feature. With the **force-report-trunk-info** parameter turned on in the session router configuration:

- The OCSBC reports terminating trunk group and trunk-context information even though it has not perform trunk-group routing. The appropriate VSAs report the terminating trunk-group (VSA 65) and trunk context (VSA 67) with the information of the matching ingress session agent and realm of the originator.
- The OCSBC reports the terminating trunk-group (VSA 66) and trunk context (VSA 68) as the received trunk group and context from the call's SIP REQUEST message. If the SIP message has none, then the OCSBC uses the information from the matching egress session agent (or egress realm, when available) and next-hop realm. Note that information is reported after HMR processing—meaning that header manipulation has been performed on the message information reported.

ACL I Instructions and Examples

You enable trunk-group VSA generation on a system-wide basis in the session-router configuration.

To enable forced trunk-group VSA generation:

1. In Superuser mode, type **configure terminal** and press Enter.

```
ORACLE# configure terminal  
ORACLE(configure)#
```

2. Type **session-router** and press Enter.

```
ORACLE(configure)# session-router  
ORACLE(session-router)#
```

3. Type **session-agent** and press Enter.

```
ORACLE(session-router)# session-router  
ORACLE(session-router)#
```

4. **forced-report-trunk-info**—Change this parameter to enabled if you want to turn on the OCSBC's ability to generate VSAs for trunk group information even when you are not using trunk-group routing. The OCSBC uses VSAs 65-68 to report originating and terminating trunk group information as described in the [Trunk-Group VSA Generation](#) section above. By default, this parameter is **disabled**.
5. Save and activate your configuration.

RADIUS Account Server Prioritization

Especially useful for customers with multiple OCSBCs, the RADIUS account server prioritization feature allows you to assign a priority to each of the account servers

you configure. Setting the priority for RADIUS accounting servers allows you to load balance traffic across the servers.

Without this feature, the OCSBC sorts RADIUS accounting servers by their IP addresses and ports. For example, if you have a pre-existing accounting server with the IP address and port combination of 10.1.31.2:1813 and then configure a new server at 10.0.3.12:2145, the new server will take priority over the pre-existing one. Of course, you always have the option of allowing the system to set the priority of your accounting servers in this way.

The prioritization feature works with all of the strategy types you set in the accounting configuration. However, it is most applicable to the **hunt** or **failover** strategies. You can assign a number to each server to mark its priority, or you can leave the priority parameter set to 0 (default) so the OCSBC prioritizes them by IP address and port.

How You Might User Server Prioritization

This example illustrates how you may benefit from using the prioritization feature if you have multiple OCSBCs sending RADIUS CDRs to multiple RADIUS servers. Consider the following OCSBCs and accounting servers.

OCSBC	Account Server1 Priority	Account Server2 Priority	Account Server3 Priority
OCSBC1	10	7	4
OCSBC2	7	4	10
OCSBC3	4	10	7
OCSBC4	10	7	4
OCSBC5	7	4	10
OCSBC6	4	10	7

If the strategy for this example is set to **hunt** or **failover** and assuming no timeouts are pending, you can see that OCSBC1 sends its accounting traffic to Account Server3 over the other two. OCSBC2 sends its traffic to Account Server2 over the others, and likewise for the remainder of OCSBCs and servers. The traffic, then, is load balanced across the servers, less likely to overburden any of them.

ACLI Instructions and Examples

This section shows you how set the priority for an account server.

1. In Superuser mode, type **configure terminal** and press Enter.

```
ORACLE# configure terminal
ORACLE(configure)#
```

2. Type **session-router** and press Enter.

```
ORACLE(configure)# session-router
ORACLE(session-router)#
```

3. Type **account-config** and press Enter.

```
ORACLE(session-router)# account-config
ORACLE(account-config)#
```

4. Type **account-server** and press Enter.

```
ORACLE(session-router)# account-server
ORACLE(account-server)#
```

5. **priority**—Enter the number corresponding to the priority you want this account server to have in relation to the other account servers to which you send traffic. The default for this parameter is 0, meaning the prioritization feature is turned off—and that the OCSBC will therefore prioritize accounting servers by IP address and port. Otherwise, you can use any numbering scheme that suits your needs and ease of use.
6. Save and activate your configuration.

Accounting Configuration Example

Using the OCSBC with external RADIUS accounting servers to generate CDRs and provide billing services requires you to configure accounting configuration and any associated accounting servers you might need.

The following example shows how you can set accounting configuration and accounting server parameters to support multiple RADIUS accounting servers.

```
ORACLE(account-config)# show
account-config
      hostname                localhost
      port                    1813
      strategy                 Hunt
      state                    enabled
      max-msg-delay            60
      max-wait-failover        100
      trans-at-close           disabled
      file-output              enabled
      max-file-size            1000000
      max-files                 5
      file-path                 /opt/cdr
      file-rotate-time         60
      ftp-push                  enabled
      ftp-address               154.0.12.4
      ftp-port                  21
      ftp-user                  Admin
      ftp-password              A213HG
      ftp-remote-path           /sdRADIUS
      cdr-output-redundancy     enabled
      generate-start            OK
      generate-interim          Reininvite-Response
      intermediate-period       0
      prevent-duplicate-attrs   disabled
      vsa-id-range
```

```

        cdr-output-inclusive
account-server
        hostname                10.0.0.189
        port                    1813
        state                   enabled
        min-round-trip          250
        max-inactivity          60
        restart-delay           30
        bundle-vsa              enabled
        secret                  acme
        NAS-ID
        priority                 0
        account-server
        hostname                192.168.200.70
        port                    5050
        state                   enabled
        min-round-trip          250
        max-inactivity          60
        restart-delay           30
        bundle-vsa              enabled
        secret                  packet
        NAS-ID
        priority

```

Local CDR Storage and FTP Push

The local CDR storage feature allows you to save RADIUS CDR data to a local CSV text file on the OCSBC. Local CDR file creation and storage can be used in addition to or independently of sending CDRs to RADIUS servers for every call. Once the OCSBC creates and saves local CDR files, you can:

- Send the files to an FTP server by configuring a push receiver
- Develop and implement your own script for retrieving them as necessary from the OCSBC

You configure the OCSBC to:

- Set directory path where you want to save local CDR files
- Set a maximum file size for the CSV file
- Set a maximum number of local CDR files
- Set an interval in which to close the existing local CDR file and begin writing a new file.

Once local CDR file creation is enabled, you can configure push receivers to push any non-active and closed CDR files to an FTP server using FTP or SFTP protocols. You configure the OCSBC with the push receiver's:

- server IP address and port information
- login credentials
- path to save the local CDR Files
- The interval at which the OCSBC should send files to a push receiver

For flexibility and security, the OCSBC can log into a push receiver with either FTP or SFTP. If you are creating a secure connection with SFTP, your OCSBC can authenticate to the server with either a public shared key or SSH-encrypted username and password.

Bear in mind that the OCSBC deletes a local CDR file after the local CDR file has been successfully transferred to a push receiver.

Local CDR File Format

The CDRs are written as comma-delimited ASCII records to files on the OCSBC. The types of records are controlled by the same accounting configuration parameters used for RADIUS. The fields of the comma-delimited entries correspond to RADIUS START, INTERIM, and STOP records. Using the accounting configuration, you can configure the OCSBC to record STOP records only.

Because the record types do not have consistent field positioning, any server parsing them would need to read the first field to determine the type and learn how to parse the remaining fields.

Local CDR File Format Consistency

Unpopulated or unused fields in the RADIUS CDR are omitted from the locally-stored CSV file. This means that there is no fixed position for a RADIUS attribute across all CSV files. Instead, the missing values are skipped in the CSV file so that the order and appearance for attribute values can differ from record to record.

You can optionally guarantee the placement of attributes in locally-stored CSV files with the **cdr-output-inclusive** parameter. With this enhancement enabled, RADIUS records sent to a RADIUS client contain even empty attributes with an integer, date and time, or IP address format; the default value is zero. In other words, when there is no value to report:

- An IP address attribute will report as 0.0.0.0
- A date and time attribute will report as 00:00:00.000 UTC Jan 01 1970
- An integer attribute value will report as 0

To maintain RFC 2865 and 2866 compliance, the Oracle Communications Session Border Controller will not send empty attributes that are string values to a RADIUS client. And when you enable this feature, the Oracle Communications Session Border Controller adds all attributes to the locally-stored CSV file.

Refer to Appendix B of this document for an example of where VSAs appear in a locally-generated CSV file for a successful Interim record.

Generate Local CDR Layout Files

Numerous factors determine the layout of local CDR files. In order to obtain an accurate local CDR layout, the SBC can write a special CDR layout file that only includes the data layout for your local CDRs based on your configuration. You can then use this file to interpret local CDR files with the proper data field order, source and identification label.

You can configure the system to produce CDR layout files with the **dump_csv_format** command at the superuser prompt.

```
ORACLE# dump_csv_format
```

This function uses the same process, input and output mechanisms the system uses to produce local CDRs. While this command is activated, the system produces layout files instead of actual CDRs. Once the layout files have been obtained, turn the generation feature off with the **no_dump_csv_format** command at the superuser prompt.

Format files are written to the same directory as local CDR files, and they use the same naming convention as local CDR files. Refer to local CDR generation instructions to identify the files you intend to retrieve, based on your configuration for rotation, naming, file size, and so forth.

Note that the push-receiver configuration may not be an efficient means of retrieving your local CDR format files because they are configured for time and size windows appropriate for CDR collection. Use SFTP manually to control what and when you retrieve.

Perform this procedure in a maintenance window. You must have complete control over prototype calls. Limit them to a single successful, and depending on your configuration, single unsuccessful call. The following is the general procedure used to capture local CDR layout files.

1. Turn on `dump_csv_format` from the system's enable prompt. The system stops generating local CDR files, generating local CDR format files instead.
2. Place a successful call.
3. Complete the call.
4. If you are configured for INTERIM generation upon an unsuccessful call, place an unsuccessful call.
5. Depending on your configuration, identify the file that has the format. For example, if using rotation you may decide to wait for the data to rotate from the temp file to be sure the file is closed.
6. Use SFTP to retrieve the layout file from the local CDR directory.
7. Turn off the feature using `no_dump_csv_format`. The system begins to generate local CDR files again.
8. Use the files to identify your CDR format and establish your collection and collation process.

Local CDR Layout File Reference and Example

Local CDR Layout File Reference and Example

The first line of every record contains the following comma-delimited information:

```
"1", "Accounting Status", , "40", ["## START ##" | "## INTERIM ##" |  
"##STOP##" ]
```

Each line after the initial line of each record contains the following comma-delimited information:

```
<CDR Attribute position>,<CDR Attribute Name>,<VSA Vendor>,<VSA Number>
```

The CDR Attribute name only presents the shorthand of the attribute. Cross-reference the VSA number with the RADIUS dictionary to obtain the full VSA name.

The following is an example of the first 10 rows of a CDR Layout file, start record.

```
1,"Accounting Status",,40,## START ##
2,"NAS IP Address",,4
3,"NAS Port",,5
4,"Accounting Session ID",,44
5,"Ingress Session ID",ACME,3
6,"Egress Session ID",ACME,4
7,"Session Protocol Type",ACME,43
8,"Session-Forked-Call-Id",ACME,171
9,"Generic ID",ACME,40
10,"Calling Station ID",,31
```

Requirements

If you want to guarantee the CSV placement for RADIUS attribute values, you must use the entire RADIUS dictionary. You cannot use the RADIUS CDR abbreviation feature. Using an abbreviated form of the RADIUS dictionary results in adverse effects for the CSV file.

In your configuration, then, you must set the **vsa-id-range** parameter to use the entire range of attributes. Leaving this parameter blank disables abbreviation and all attributes are included. Alternatively, you can specify all of the parameters (by attribute number) that are used in the OS release loaded on your system.

See the [RADIUS CDR Content Control](#) section for more information.

Local CDR File Naming Convention

Filenames are derived from the date and time that the CDR file is opened for writing. The format is cdrYYYYMMDDHHMM[a-j], where:

- YYYY=the year
- MM=the month
- DD=the day
- HH=the hour
- MM=the minute
- [a-j]=a suffix that provides additional discrimination in case of changing system time, setting the rotation time for this feature to one minute, or in case of another occurrence that might compromise the date and time

Your file name will resemble the following sample: cdr200511151200.

Call Detail Record Sequence Number in Filename

To assist in the identification of lost Call Detail Record (CDR) files, the customer can enable the **file-seq-number** attribute to assign a sequence number to append to the file. A separate configuration element, **temp-remote-file**, allows for the prepending of the characters "tmp-" to CDR files during transfer.

Sometimes there are failures in the transmission of CDR files due to underlying network or infrastructure issues. Customers can identify missing files through the combination of a timestamp (YYYYMMDDMM) and 9-digit unique sequence numbers (SNs) appended to the file. This behavior is enabled through the **file-seq-number** attribute. The SN will start from one at boot time. This attribute replaces the use of alpha characters (a-z) appended to the CDR file name when more than one file is created in the same minute.

Separately, one can set the **temp-remote-file** attribute so the characters "tmp-" are prepended to the CDR file during transfer. Once delivered, the file will be renamed on the remote host to remove "tmp-".

For example, with both attributes enabled, a file named **tmp-cdr<timestamp>-<9-digit-sequence-number>** would be created and upon complete transfer to the destination renamed **cdr<timestamp>-<9-digit-sequence-number>**.

CDR Sequence Number in Filename Configuration

To assist in the identification of lost Call Detail Record (CDR) files, the customer can enable the **file-seq-number** attribute to allow a sequence number to append to the file.

1. Access the **account-config** configuration element.

```
ORACLE# configure terminal
ORACLE(configure)# session-router
ORACLE(session-router)# account-config
ORACLE(account-config)#
```

2. Type **select** to begin configuring this object.
3. **file-seq-number**—set this to enabled for the system to assign a 9 digit file sequence number to append to a CDR file. The default is disabled.
 - **enabled | disabled**
4. Type **done** to save your configuration.

Temp-remote-file creation for CDR files during transfer Configuration

The configuration element **temp-remote-file** allows for the prepending of the characters "tmp-" to Call Detail Record (CDR) files during transfer. When the transfer ends successfully, the system removes the characters "tmp-".

1. Access the **push-receiver** configuration element.

```
ORACLE# configure terminal
ORACLE(configure)# session-router
ORACLE(session-router)# account-config
```

```
ORACLE(account-config)# push-receiver
ORACLE(push-receiver)#
```

2. Select the **push-receiver** object to edit.

```
ORACLE(push-receiver)# select
server:
1: server = 192.168.100.101, port = 21

selection: 1
ORACLE(push-receiver)#
```

3. **temp-remote-file**—set the state of this element to enabled for the system to prepend the characters "tmp-" to a CDR file during transfer. The default is disabled
 - **enabled | disabled**
4. Type **done** to save your configuration.

Local CDR File Storage Directories

The OCSBC only allows local storage of ASCII CDRs to the /opt and /opt/logs directories. If you try to save to another directory (such as /code or /boot), you will receive an error message.

If you are using the ACLI and enter an inappropriate directory, the ACLI will issue an error message.

Local CDR File Size and Rotation

You can configure maximum file size, maximum number of local CSV files to store, and the interval at which the files rotate.

The OCSBC saves up to the file size limit (**max file size**) and maintains only number of files that you configure (**max files**). When the maximum file size is reached, the OCSBC closes that file and begins writing VSA attributes and values to a new local CDR file. When it is time for the OCSBC to write the **max files** + 1 file, the oldest file is deleted so that the newest one can be stored.

More About File Rotation Time

You can use the CDR local storage feature on its own, without enabling the ftp push feature. The OCSBC uses a period of time that you set to periodically rotate the files. The **file rotate time** parameter rotates the local CSV files regardless of whether you use the FTP push feature.

RADIUS CDR Redundancy

When you are using the RADIUS CDR storage and FTP push feature, the OCSBC can create a redundant copy of the comma-delimited CDR files that it stores on the standby system in the HA node.

This enhancement to the CDR storage feature ensures against data loss if, for example, an active OCSBC fails immediately before an FTP push. The standby has

a duplicate set of records that it sends. This feature is enabled with the **CDR output redundancy** parameter found in the **account config** configuration element.

Caveats for H.323

H.323 calls proceed without interruption over an HA node in the event of a failover from one OCSBC to another, and RADIUS records are generated and duplicated across the active and standby systems in an HA node. However if a switchover occurs during an H.323 call (that has been initiated, but not completed), the newly active (formerly standby) system will not generate RADIUS Stop records when the call completes.

FTP Push

The FTP push feature is used to copy local CDR files to a remote FTP server on a periodic basis. This feature is configured by defining push receivers which contain standard login and FTP server credentials of the remote machine. At the configured time interval (**file rotate time**), the OCSBC closes the current file, and pushes the files that are complete and have not yet been pushed; including the just-closed-file.

Deprecated ACLI Configuration

The following parameters in the account-config configuration element are deprecated:

- ftp-address
- ftp-port
- ftp-user
- ftp-password
- ftp-remote-path

These parameters will only be used if no **account-config, push-receiver** configuration elements have been defined. All new push receivers must be defined in the **account-config, push-receiver** configuration element.

Multiple Push Receivers

OCSBC now supports up to five CDR push receivers for use with the local file storage and FTP push feature. For each receiver you configure, you can set the file transfer protocol you want to use—either FTP or SFTP. The system uses the push receivers according to the priorities you set by giving a 0 through 4 priority number to the server when you configure it; 0 is the highest priority, and 4 is the lowest. By default, push receivers always have their priority at the lowest setting (4).

Based on the priority level you set, the OCSBC uses a strategy (which you also set) to select a CDR push receiver. If the highest priority push receiver selected using the strategy becomes unavailable (i.e., times out), the OCSBC uses the strategy (hunt, round robin, etc.) to select another.

This feature is dynamically configurable. When you change the configuration, the OCSBC updates the list of push receivers if it has changed.

Push Receivers

A push receiver configuration includes all the credentials that the OCSBC needs to log into an FTP server and upload any recent local CDR files. Push receiver configurations must include:

- the server's IP address and port
- remote path of where to upload the local CDR files
- protocol used to connect to the server
- account login credentials

Secure FTP Push Configuration

You can configure the Oracle Communications Session Border Controller (OCSBC) to securely log on to a push receiver using one of the following methods that creates a secure connection.

Password authentication—Set the **protocol** parameter on the push receiver to SFTP, configure a username and password, and leave the **public-key** parameter blank. Note that you must also import the host key from the SFTP server to the OCSBC for this type of authentication.

Public key authentication—Set the **protocol** parameter on the push receiver to SFTP, set the **public-key** parameter to a configured public key record name including an account **username**, and configure your SFTP server with the public key pair from the OCSBC.

It is often difficult to determine whether the SFTP server uses its RSA key or its DSA key for its server application. For this reason, Oracle recommends that you import both the RSA key and the DSA key to the OCSBC to ensure a successful FTP Push.

It is also common for the SFTP server to run the Linux operating system. For Linux, the command `ssh-keygen -e` creates the public key that you need to import to the OCSBC. The `ssh-keygen -e` command sequence requires you to specify the file export type, as follows.

```
[linux-vpn-1 ~]# ssh-keygen -e
Enter file in which the key is (/root/.ssh/id_rsa): /etc/ssh/
ssh_host_rsa_key.pub
```

If you cannot access the SFTP server directly, but you can access it from another Linux host, use the `ssh-keyscan` command to get the key. An example command line follows.

```
root@server:~$ssh-keyscan -t dsa sftp.server.com
```

ACLI Instructions and Examples

This section shows you how to configure Local CDR storage and FTP push on your OCSBC.

Accessing the Accounting Configuration

To configure parameter for these features, you must access the accounting configuration.

To access the accounting configuration:

1. In Superuser mode, type **configure terminal** and press Enter.

```
ORACLE# configure terminal
```

2. Type **session-router** and press Enter.

```
ORACLE(configure)# session-router
```

3. Type **account-config** and press Enter.

```
ORACLE(session-router)# account-config  
ORACLE(account-config)#
```

From here, you can enable local CDR storage and FTP push.

Enabling Local CDR Storage

To enable local CDR storage:

1. **file-output**—Enable this parameter for the OCSBC to create comma-delimited CDRs (generated from RADIUS records). By default, this parameter is disabled.
2. **file-path**—You must configure this path for the CDR push feature to work. Set the path to use on the OCSBC for file storage:
 - /opt
 - /opt/logs

To use FTP push, you must configure a usable path.

 **Note:**

When a Hard Disk Drive is available, you may opt to store CDRs in the data-disk.

3. **max-file-size**—Set the maximum CDR file size in bytes. The default and minimum value is 1000000. Oracle recommends you limit local CDR storage on your system to 30M. For example, if you retain the **max-file-size** default, set **max-files** to 30. However, if you are using a Storage Expansion Module the maximum value is 108.
4. **max-files**—Set the maximum number of files to be stored on the OCSBC at one time. The parameter's value range is from 0 to unlimited. The user should consider the max-file-size setting, the 30M recommendation, and their preferences to specify this value. The default is 5.
5. **file-rotate-time**—Set how often in minutes you want to rotate the stored files; the OCSBC will overwrite the oldest file first. The minimum rotation time is 2 minutes;

the default is 60 minutes. This parameter defaults to 0, and leaving it set to the default means that the OCSBC will not rotate the files.

6. **cdr-output-redundancy**—Set this parameter to enabled for the OCSBC to store a redundant copy of the local CSV file to the standby HA node. Set this parameter to standby-push to enable the function and enable local storage and implement push capabilities on an HA deployment's standby to protect against CDR data loss.

Configuring a Push Receiver Fallback Method

You set the push receiver strategy and define the maximum timeout in seconds in the main accounting configuration.



Note:

You may ignore the following two parameters if only one push receiver is configured.

1. **ftp-strategy**—Set the strategy you want the OCSBC to use when selecting from multiple push receivers. The default is **hunt**.
 - Hunt—The OCSBC selects the push receiver from the available list according to the priority level. The system uses this strategy as its default.
 - Failover—The OCSBC selects the push receiver based on priority level and will continue to use that same push receiver until it fails over.
 - RoundRobin—The OCSBC selects push receivers systematically one after another, balancing the load among all responsive push receivers.
 - FastestRTT—The OCSBC selects the push receiver based on best average throughput. For this situation, throughput is the number of bytes transferred divided by the response time. The system uses a running average of the five most recent throughput values to accommodate for network load fluctuations.
2. **ftp-max-wait-failover**—Enter the amount of time in seconds to wait before the OCSBC declares a push receiver to have failed over. This default value for this parameter is **60**.

Setting the CSV File Format

This section shows you how to guarantee the CSV placement for RADIUS attribute values by using the entire RADIUS dictionary.

To enable fixed value placement in CSV files for RADIUS CDRs:

1. In Superuser mode, type **configure terminal** and press Enter.

```
ORACLE# configure terminal  
ORACLE(config)#
```

2. Type **session-router** and press Enter.

```
ORACLE(config)# session-router
```

3. Type **account-config** and press Enter.

```
ORACLE(session-router)# account-config  
ORACLE(account-config)#
```

If you are adding support for this feature to a pre-existing accounting configuration, then you must use the ACLI **select** command so that you can edit it.

4. **vsa-id-range**—Either leave this parameter blank (default), or enter the complete range of VSAs loaded on your system. The following example shows what you might enter to use all of the VSAs for a system that is not running QoS.

```
ORACLE(account-config)# vsa-id-range  
1-4,10-14,20-24,28,29,32-71,74-136
```

5. **cdr-output-inclusive**—When disabled (default), the system excludes fields that have no data from the CSV file. Set to enabled to make the system include all fields in every CSV file. This ensures that there are always the same number of fields in all equivalent records. Start records would always have the same number of fields. The same would be true of interim and stop records.

Enabling FTP Push

To enable FTP push:

1. In Superuser mode, type **configure terminal** and press Enter.

```
ORACLE# configure terminal  
ORACLE(configure)#
```

2. Type **session-router** and press Enter.

```
ORACLE(configure)# session-router
```

3. Type **account-config** and press Enter.

```
ORACLE(session-router)# account-config
```

If you are adding support for this feature to a pre-existing accounting configuration, then you must use the ACLI **select** command so that you can edit it.

4. **ftp-push**—Set the state of FTP push feature to **enabled**. It is disabled by default.
5. Type **push-receiver** and press Enter.

```
ORACLE(account-config)# push-receiver
```

6. **server**—Enter the IP address of this push receiver FTP server.
7. **port**—Enter the port number of this push receiver FTP server.
8. **remote-path**—Enter the remote pathname to which you want CDR files to be sent on the push receiver. There is no default for this parameter.

9. **filename-prefix**—Enter the filename prefix (as a string) to prepend to the to the CDR files the OCSBC sends to the push receiver. The OCSBC does not rename local files. There is no default for this parameter.
10. **protocol**—Enter **SFTP** if you want to change the transport protocol for this push receiver from its default, **FTP**.
11. **username**—Enter the username the OCSBC uses when connecting to this push receiver. There is no default for this parameter. This parameter is always required.
12. **password**—Enter the password corresponding to the username the OCSBC uses when connecting to this push receiver. There is no default for this parameter. You can leave this field blank if you are using public key authentication. Profile configuration is required for both password and public key authentication.
13. **public-key**—Enter the public key profile to use for authentication to this push receiver and decryption of this servers packets. Note the procedure below, which tells you how to create a public key profile. You can leave this field blank if you are using password authentication. Profile configuration is required for both password and public key authentication.
14. Save and activate your configuration.

Creating a Public Key Profile

The Secure Shell (SSH) and related Secure Shell File Transfer (SFTP) protocols provide for the secure transfer of audit files and for the secure transfer of management traffic across the wancom0 interface. When using password or public key authentication with push receiver configurations, use the procedures described below to create your profiles.

Create your profile by configuring:

- SSH Properties
- Import an SSH Host Key
- Create the public key profile

The following two tasks are required for public key authentication mode only.

- Generate an SSH Key Pair
- Copy the OCSBC public key to the SFTP server

After the above, you can use this profile within the context of your FTP push configuration.

SSH Operations

SSH Version 2.0, the only version supported on the Oracle OCSBC, is defined by a series of five RFCs.

- RFC 4250, The Secure Shell (SSH) Protocol Assigned Numbers
- RFC 4251, The Secure Shell (SSH) Protocol Architecture
- RFC 4252, The Secure Shell (SSH) Authentication Protocol
- RFC 4253, The Secure Shell (SSH) Transport Layer Protocol
- RFC 4254, The Secure Shell (SSH) Connection Protocol

RFCs 4252 and 4253 are most relevant to OCSBC operations.

The transport layer protocol (RFC 4253) provides algorithm negotiation and key exchange. The key exchange includes server authentication and results in a cryptographically secured connection that provides integrity, confidentiality and optional compression. Forward security is provided through a Diffie-Hellman key agreement. This key agreement results in a shared session key. The rest of the session is encrypted using a symmetric cipher, currently 128-bit AES, Blowfish, 3DES, CAST128, Arcfour, 192-bit AES, or 256-bit AES. The client selects the encryption algorithm to use from those offered by the server. Additionally, session integrity is provided through a cryptographic message authentication code (hmac-md5, hmac-sha1, umac-64 or hmac-ripemd160).

The authentication protocol (RFC 4252) uses this secure connection provided and supported by the transport layer. It provides several mechanisms for user authentication. Two modes are supported by the OCSBC: traditional password authentication and public-key authentication.

ACLI Instructions and Examples

This section provides ACLI procedures for SFTP push configurations, including SSH property configuration, certificate import, and public key profile configuration on your OCSBC.

Configure SSH Properties

The single instance **ssh-config** configuration element specifies SSH re-keying thresholds.

1. Access the **admin-security** configuration element.

```
ORACLE# configure terminal
ORACLE(configure)# security
ORACLE(security)# admin-security
```

2. Access the **ssh-config** subelement.

```
ORACLE(admin-security)# ssh-config
ORACLE(ssh-config)#
```

3. **rekey-interval**—specifies the maximum allowed interval, in minutes, between SSH key negotiations.

Allowable values are integers within the range 60 through 600, with a default of 60 (minutes). Shorter lifetimes provide more secure connections.

Works in conjunction with **rekey-byte-count**, which sets a packet-based threshold, to trigger an SSH renegotiation. If either trigger is activated, an SSH renegotiation is begun.

Retain the default value, or specify a new value.

```
ragnarok(ssh-config)# rekey-interval 20
ragnarok(ssh-config)
```

4. **rekey-byte-count**—specifies the maximum allowed send and receive packet count, in powers of 2, between SSH key negotiations

Allowable values are integers within the range 20 (1,048,576 packets) through 31 (2,147,483,648 packets), with a default of 31 (231). Smaller packet counts provide more secure connections.

Works in conjunction with **rekey-interval**, which sets a time-based threshold, to trigger an SSH renegotiation. If either trigger is activated, an SSH renegotiation is begun.

Retain the default value, or specify a new value.

```
ragnarok(ssh-config)# rekey-packet-count 24
ragnarok(ssh-config)
```

A sample SSH configuration appears below:

```
ragnarok(ssh-config)# rekey-interval 20
ragnarok(ssh-config)# done
ragnarok(ssh-config)# exit
ragnarok(admin-security)#
```

Specifies a key renegotiation every 20 minutes, or at the reception/transmission of 2,147,483,648 packets, whichever comes first.

Import an SSH host Key

Importing a host key requires access to the SFTP server or servers which receive audit log transfers. Access is generally most easily accomplished with a terminal emulation program such as PuTTY, SecureCRT, or TeraTerm.

1. Use a terminal emulation program to access the SSH file system on a configured SFTP server.
2. Copy the server's base64 encoded public file making sure to include the Begin and End markers as specified by RFC 4716, *The Secure Shell (SSH) Public Key File Format*.

For OpenSSH implementations host files are generally found at `/etc/ssh/ssh_host_dsa_key.pub`, or `/etc/ssh/ssh_host_rsa.pub`. Other SSH implementations can differ.

3. From admin mode use the **ssh-pub-key** command to import the host key to the OCSBC.

For importing a host key, this command takes the format:

```
ssh-pub-key import known-host <name>
```

where name is an alias or handle assigned to the imported host key, generally the server name or a description of the server function.

```
ORACLE# ssh-pub-key import known-host fedallah
```

IMPORTANT:

Please paste ssh public key in the format defined in rfc4716.
Terminate the key with ";" to exit.....

4. Paste the public key with the bracketing Begin and End markers at the cursor point.
5. Enter a semi-colon (;) to signal the end of the imported host key.
6. Follow directions to save and activate the configuration.

The entire import sequence is shown below.

```
ORACLE# ssh-pub-key import known-host fedallah

IMPORTANT:
  Please paste ssh public key in the format defined in rfc4716.
  Terminate the key with ";" to exit.....

---- BEGIN SSH2 PUBLIC KEY ----
Comment: "2048-bit RSA, converted from OpenSSH by klee@acme54"
AAAAB3NzaC1yc2EAAAABIwAAAQEA7OBf08jJe7MSMgerjDTgZpbPblrX4n17LQJgPC7c
LL
cDGEtKSivt5MjcSav3v6AEN2pYZih0xd2Zzismpoo019kkJ56s/
IjGstEzqXMKHKUr9mBV
qvqIEOTqbowEi5sz2AP31GUjQTCKZRF1XOQx8A44vHZCum93/
jfNRsnWQ1mhHmaZMmT2LS
hOr4J/
Nlp+vpsvpdrolV6Ftz5eiVfgocxrDrjNcVtsAMyLBpDdL6e9XebQzGSS92TPuKP/
yqzLJ2G5NVFhxdw5i+FvdHz1vBdvB505y2QPj/izlu3TA/
307tyntBOb7beDyIrg64Azc8
G7E3AGiH49LnBtlQf/aw==
---- END SSH2 PUBLIC KEY ----
;
SSH public key imported successfully...
WARNING: Configuration changed, run "save-config" command to save it
and run "activate-config" to activate the changes
ORACLE# save-config
checking configuration
-----
-
...
...
...
-----
-
Save-Config received, processing.
waiting for request to finish
Request to 'SAVE-CONFIG' has Finished,
Save complete
Currently active and saved configurations do not match!
To sync & activate, run 'activate-config' or 'reboot activate'.
ORACLE# activate-config
Activate-Config received, processing.
waiting for request to finish
SD is not QOS-capable
Request to 'ACTIVATE-CONFIG' has Finished,
```

```
Activate Complete
ORACLE#
```

It is important to note that it is often difficult to determine whether the server is using RSA or DSA keys for your application. Unless you can definitively determine this, bear in mind that you need to try importing both.

Create the Public Key Record

The initial step in generating an SSH key pair is to configure a public key record which will serve as a container for the generated key pair.

1. Navigate to the **public-key** configuration element.

```
ORACLE# configure terminal
ORACLE(configure)# security
ORACLE(security)# public-key
ORACLE(public-key)#
```

2. Use the **name** command to provide the object name, and the **show** command to verify object creation.

```
ORACLE(public-key)# name KeyTest
ORACLE(public-key)# show
public-key
      name                KeyTest
      type                 rsa
      size                 1024
      last-modified-by
      last-modified-date
```

This command creates a public key record named `tashtego`.

3. Use the **done** command to complete object creation.

```
ORACLE(public-key)# done
public-key
      name                KeyTest
      type                 rsa
      size                 1024
      last-modified-by    admin@console
      last-modified-date  2014-05-14 14:40:55

ORACLE(public-key)#
```

4. Make a note of the **last-modified-date** time value.
5. Move back to admin mode, and save and activate the configuration.

```
ORACLE(public-key)# exit
ORACLE(security)# exit
ORACLE(configure)# exit
ORACLE#
```

```
ORACLE# save-config
...
...
...
ORACLE# activate-config
...
...
...
ORACLE#
```

Generate an SSH key pair

1. Now use the **ssh-pub-key generate** command, in conjunction with the name of the public key record created in Step 3, to generate an SSH key pair.

For importing an SSH key pair, this command takes the format:

```
ssh-pub-key generate <name>
```

where name is an alias or handle assigned to the generated key pair, generally the client name or a description of the client function.

```
ORACLE# ssh-pub-key generate tashtego
Please wait...
public-key 'tashtego' (RFC 4716/SECSH format):
---- BEGIN SSH2 PUBLIC KEY ----
Comment: "1024-bit rsa"
AAAAB3NzaC1yc2EAAAABIwAAAIEArZEP1/WiYsdGd/
Pi8V6pnSwV4cVG4U+jVOwiSwNJCC9Nk82/
FKYleLZevy9D3lrZ8ytvu+sCYy0fNk4nwvz20c2N+r86kDru88JkUqpelJDx1AR718Ic
pr7ZaAx2L+e7cpyRSXCgbQR7rXu2H3bp9Jc0VhR2fmkclmrGAIr7Gnc=
---- END SSH2 PUBLIC KEY ----

SSH public-key pair generated successfully...
WARNING: Configuration changed, run "save-config" command to save
it and run "activate-config" to activate the changes
ORACLE#
```

2. Copy the base64-encoded public key. Copy only the actual public key — do not copy the bracketing Begin and End markers nor any comments. Shortly you will paste the public key to one or more SFTP servers.
3. Save and activate the configuration.

```
ORACLE# save-config
...
...
...
ORACLE# activate-config
...
...
...
ORACLE#
```

- Return to the public-key configuration object, and select the target public key record instance.

```
ORACLE# configure terminal
ORACLE(configure)# security
ORACLE(security)# public-key
ORACLE(public-key)# sel
<name>:
1: acme01
2: acme02
3: tashtego

selection: 3
ORACLE(public-key)# show
public-key
      name           tashtego
      type           rsa
      size           1024
      last-modified-by admin@console
      last-modified-date 2009-03-06 11:24:32
ORACLE(public-key)#
```

- Verify that the record has been updated to reflect key generation by examining the value of the last-modified-date field.

Copy the RSA Public Key to the SFTP Server

Copy the RSA public key from the from the Oracle Communications Session Border Controller (OCSBC) to the `authorized_keys` file in the `.ssh` directory on the SFTP server.

- Confirm that the `.ssh` directory exists on the SFTP server.
- Confirm the following permissions: `Chmod 700` for `.ssh` and `Chmod 600` for `authorized_keys`.

When adding the RSA key to the `authorized_keys` file, ensure that no spaces occur inside the key. Insert one space between the `ssh-rsa` prefix and the key. Insert one space between the key and the suffix. For example, `ssh-rsa <key> root@1.1.1.1`.

- Access the SSH file system on a configured SFTP server with a terminal emulation program.
- Copy the RSA key to the SFTP server, using a text editor such as `vi` or `emacs`, and paste the RSA key to the end of the `authorized_keys` file.

View a Public key on the OCSBC

You can use the `show security ssh-pub-key` command to display information about SSH keys imported to the OCSBC with the `ssh-pub-key` command; you cannot display information about keys generated by the `ssh-pub-key` command.

```
ORACLE# show security ssh-pub-key brief
login-name:
  acme74
finger-print:
```

```
51:2f:f1:dd:79:9e:64:85:6f:22:3d:fe:99:1f:c8:21
finger-print-raw:
0a:ba:d8:ef:bb:b4:41:d0:dd:42:b0:6f:6b:50:97:31

login-name:
fedallah
finger-print:
c4:a0:eb:79:5b:19:01:f1:9c:50:b3:6a:6a:7c:63:d5
finger-print-raw:
ac:27:58:14:a9:7e:83:fd:61:c0:5c:c8:ef:78:e0:9c
ORACLE#
```

This command displays summary information for all SSH imported keys.

- `login-name`: contains the name assigned to the RSA or DSA public key when it was first imported.
- `finger-print`: contains the output of an MD5 hash computed across the base64-encoded public key.
- `finger-print-raw`: contains the output of an MD5 hash computed across the binary form of the public key

```
ORACLE# show security ssh-pub-key brief fedallah
login-name:
fedallah
finger-print:
c4:a0:eb:79:5b:19:01:f1:9c:50:b3:6a:6a:7c:63:d5
finger-print-raw:
ac:27:58:14:a9:7e:83:fd:61:c0:5c:c8:ef:78:e0:9c
ORACLE#
```

This command displays summary information for a specific SSH public key (in this case `fedallah`).

```
ORACLE# show security ssh-pub-key detail fedallah
host-name:
fedallah
comment:
"2048-bit RSA, converted from OpenSSH by klee@acme54"
finger-print:
c4:a0:eb:79:5b:19:01:f1:9c:50:b3:6a:6a:7c:63:d5
finger-print-raw:
ac:27:58:14:a9:7e:83:fd:61:c0:5c:c8:ef:78:e0:9c
pub-key:

AAAAB3NzaC1yc2EAAAABIwAAAQEA7OBf08jJe7MSMgerjDTgZpbPblrX4n17LQJgPC7c1LcD
GETKSivt5MjcSav3v6AEN2pYZihOxd2Zzismpoo019kkJ56s/
IjGstEzqXMKHKUr9mBVqvqIEOTqbowEi5sz2AP31GUjQTCKZRF1XOQx8A44vHZCum93/
jfNRsnWQ1mhHmaZMmT2LShOr4J/
Nlp+vpsvpdro1V6Ftz5eiVfgocxrDrjNcVtsAMyLBpDdL6e9XebQzGSS92TPuKP/
yqzLJ2G5NVFhxdw5i+FvdHz1vBdvB505y2QPj/iz1u3TA/
307tyntB0b7beDyIrg64Azc8G7E3AGiH49LnBt1Qf/aw==

modulus: (256)
```



```
ECE05FD3C8C97BB3123207AB8C34E06696CF6E5AD7E27D7B2D02603C2EDC94B703184B4A
4A256DE4C8DC49ABF7BFA004376A5866284EC5DD99CE2B26A68A34D7D924279EACFC88C6
B2D133A9730A1CA52BF66055AAFA8810E4EA6E8C048B9B33D803F7D4652341308A651175
5CE431F00E38BC7642BA6F77FE37CD46C9D64359A11E66993264F62D284EAF827F365A7E
BE9B2FA5DAE8955E85B73E5E8957E0A1CC6B0EB8CD715B6C00CC8B0690DD2FA7BD5DE6D0
CC6492F764CFB8A3FFCAACCB2761B9355161C5DC398BE16F747CF5BC176F079D39CB640F
8FF8B3D6EDD303FDCEEDCA7B4139BEDB783C88AE0EB803373C1BB137006887E3D2E706D
9507FF6B
exponent: (1)
23
ORACLE#
```

This command displays detailed information for specific SSH public key (in this case fedallah, an RSA key).

- host-name: contains the name assigned to the RSA key when it was first imported
- finger-print: contains the output of an MD5 hash computed across the base64-encoded RSA public key
- finger-print-raw: contains the output of an MD5 hash computed across the binary form of the RSA public key
- public key: contains the base64-encoded RSA key
- modulus: contains the hexadecimal modulus (256) of the RSA key
- exponent: (also known as public exponent or encryption exponent) contains an integer value that is used during the RSA key generation algorithm. Commonly used values are 17 and 65537. A prime exponent greater than 2 is generally used for more efficient key generation.

```
ORACLE# show security ssh-pub-key detail acme74
host-name:
  acme74
comment:
  DSA Public Key
finger-print:
  51:2f:f1:dd:79:9e:64:85:6f:22:3d:fe:99:1f:c8:21
finger-print-raw:
  0a:ba:d8:ef:bb:b4:41:d0:dd:42:b0:6f:6b:50:97:31
pub-key:
```

```
AAAAB3NzaC1kc3MAAACBAPY8ZOHY2yFSJA6XYC9HRwNHxaehvx5wOJ0rzZdzoSOXxbETW6To
Hv8D1UJ/
z+zHo9Fiko5XybZnDIaBDHtblQ+Yp7StxyltHnXF1YLfKD1G4T6JYrdHYI14Om1eg9e4NnCR
leaqoZPF3UGfZia6bXrGTQf3gJq2e7Yisk/
gF+1VAAAAFQDb8D5cvwHWTZDPfX0D2s9Rd7NBvQAAAIEA1N92+Bb7D4KLYk3IwRbXblwXdkP
ggA4pfdtW9vGfJ0/RHd+NjB4eolD+0dix6tXwYGN7PKS5R/
FXPNwxHPapcj9uLlJn2AWQ2dsknf+i/
FAAvioUPkmdMc0zuWoSOEsSNhVDTX3WdvVcGcBq9cetzrtOKW0ocJmJ80qadxTRHtUAAACBA
N7CY+KKv1gHpRzFwdQm7HK9bb1LAo2KwaoXnadFgeptNBQeSXG1vO+JsvphVMBJc9HSn24VY
tYtsMu74qXviYjziVucWKjKEb11juqnF0GD1B3VVmxHLMxnAz643WK42Z7dLM5sY29ouevz
4Xz2PuMch5VGPP+CDqzCM4loWgV
```

```
p: (128)
F63C64E1D8DB2152240E97602F47470347C5A7A1BF1E70389D2BCD9773A12397C5B1135B
```

```
A4E81EFF03D5427FCFECC7A3D162928E57C9B6670C86810C7B5B950F98A7B4ADC7296D1E  
75C5D582DF283D46E13E8962B747608D783A6D5E83D7B836709195E6AAA193C5DD419F66  
26BA6D7AC64D07F7809AB67BB622B24FE017ED55
```

```
q: (20)  
DBF03E5CBF01D64D90CF7D7D03DACF5177B341BD
```

```
g: (128)  
94DF76F816FB0F828B624DC8C116D76E5C177643E0800E297DDB56F6F19F274FD11DDF8D  
8C1E1EA350FED1D8B1EAD5F060637B3CA4B947F1573CDC311CF6A9723F6E2F5267D80590  
D9DB249DFFA2FC5000BE2A143E499D31CD33B96A12384B12361543B57DD676F55C19C06A  
F5C7ADCEBB4E2963A8709989F34A9A7714D11ED5
```

```
pub_key: (128)  
DEC263E28ABF5807A51CC5C1D426EC72BD6DBD4B028D8AC1AA179DA74581EA6D34141E49  
71B5BCEF89B2FA6154C04973D1D29F6E1562D62DB0CBBBE2A5EF8988F3895B9C58A8E328  
46F5D63BAA9C5D060E50775559B11CB9B19C0CFAE3758AE3667B74B339B18DBDA2E7B3BF  
85F3D8FB8C721E5518F3FE083AB308CE25A16815  
ORACLE#
```

This command displays detailed information for specific SSH public key (in this case acme74, a DSA key).

- host name: contains the name assigned to the DSA public key when it was first imported
- comment: contains any comments associated with the DSA key
- finger-print: contains the output of an MD5 hash computed across the base64-encoded DSA public key
- finger-print-raw: contains the output of an MD5 hash computed across the binary form of the DSA public key
- public key: contains the base64 encoded DSA key
- p: contains the first of two prime numbers used for key generation
- q: contains the second of two prime numbers used for key generation
- g: contains an integer that together with p and q are the inputs to the DSA key generation algorithm

```
ORACLE# show security ssh-pub-key detail  
...  
...  
...  
ORACLE#
```

This command displays detailed information for all SSH imported keys.

Temporary File Naming for an Open CDR File

As of Release S-C(X)6.0.0M7, the OCSBC uses a temporary naming convention that makes it easier for you to retrieve CDR files you want.

Before this release was introduced, the OCSBC used the same naming format for all CDR files: **cdrYYYYMMDDHHMM[a-j]**. If this is the naming convention you still want to use, you can do so simply by adding the **disable-temp-file** option to your accounting configuration. This mode offers no means of differentiating a file to which the OCSBC is writing information from any other closed file(s).

If you decide to use the new default behavior, then you will now see a the **temp-**prefix added to the file format. So the file format for the temp file is: **temp-cdrYYYYMMDDHHMM[a-j]**. The prefix helps you differentiate the file that is currently open from the other CDR files you encounter; this is the file to which the OCSBC is currently writing information and is open. As soon as the file is closed during rotation, the **temp-** disappears and the file bears only name in the **cdrYYYYMMDDHHMM[a-j]**. In other words, files in the **cdrYYYYMMDDHHMM[a-j]** are closed files.

Without this differentiation, it is possible for you to retrieve different versions of the same file and to even do so more than once. In addition, without the **temp-** differentiation, the OCSBC SFTP server is liable to return error messages when move or delete operations occur. These occurrences can trigger false alarms and are not consistent with other vendors' products.

Operational Details

This section offers details of OCSBC operations that effect temporary CDR file naming.

- **Reboot**—A system reboot can happen unexpectedly, or might be caused by your intentionally rebooting the system using the ACLI **reboot** command. When a reboot occurs, OCSBC closes the CDR file that was most recently opened (before the reboot) and names it according to the **cdrYYYYMMDDHHMM[a-j]** convention. It also opens a new file, which bears the **temp-** differentiation.
- **Activating a configuration**—If temporary CDR naming is enabled before and after you use the **activate-config** command, then the last opened file will be closed and have the **cdrYYYYMMDDHHMM[a-j]** name format. The OCSBC also opens a new file with the **temp-** prefix to which it will write data.
In the case where temporary CDR naming is enabled before you activate a configuration and disabled after it, the last open file is named according to the **cdrYYYYMMDDHHMM[a-j]** name format. The new file to which the OCSBC will write data is also in the **cdrYYYYMMDDHHMM[a-j]** name format. In other words, the OCSBC does not use the **temp-** prefix designation at all.
In the case where temporary CDR naming is disabled before you activate a configuration and enabled after it, the OCSBC closes the most recently opened file—which must have been in the **cdrYYYYMMDDHHMM[a-j]** name format. The OCSBC also opens a new file with the **temp-** prefix to which it will write data.
- **Changing the accounting configuration's administrative state**—When you disable the accounting configuration, the OCSBC renames the most recently opened file with the **temp-** prefix to the **cdrYYYYMMDDHHMM[a-j]** name format.

HA Considerations

The considerations in this section describes the Oracle Communications Session Border Controller's behavior when CDR output redundancy is enabled or disabled. You set CDR output redundancy in the accounting configurations **cdr-output-redundancy** parameter.

- **Enabled**—When you enable CDR output redundancy, both the Active and Standby systems rotate files. During CDR file rotation, if either the Active or the Standby rotates a file with the **temp-** prefix, the prefix disappears and the file name appears in the **cdrYYYYMMDDHHMM[a-j]** name format. The Active and the Standby systems always have the same files, including the CDR file with the **temp-** prefix. So the file exists on both systems.
- **Disabled**—When you have disables CDR output redundancy and switchover happens for any reason, it is key that there are no residual files with the **temp-** prefix. For this reason, the OCSBC handles the situation as follows:

Becoming Active—When it transitions from Standby to Active, a OCSBC checks for any files with the **temp-** prefix, closes the file if it is open, and renames it according to the **cdrYYYYMMDDHHMM[a-j]** name format. These actions means that the file is not only renamed, but that it is also rotated. Rotation triggers the creation of a new CDR file with the **temp-** prefix to use for new CDR data.

Becoming Standby—When it transitions from Active to Standby, a OCSBC closes the open **temp-** prefix file and renames it according to the **cdrYYYYMMDDHHMM[a-j]** name format. Rotation creates a new **temp-** prefix file on the Standby, which remains empty until it transitions back to the Active state.
- **Standby push**—provides the user with a mechanism to manage CDRs in a High Availability (HA) environment that prevents CDR loss during HA events. When the user configures this setting, the standby can SFTP files to the CDR server. When the decision is made to become standby the system looks for any un-pushed CDRs that are still present and pushes those to the CDR server.

This process addresses two potential data loss issues:

- When an active node fails over, there may be temporary CDRs that have not yet been pushed to the CDR server. If the standby cannot send the record to the CDR server itself, the data is lost, resulting in the call not being charged.
- Temporary CDRs files often contain incomplete data and can be present on both the active and standby OCSBCs. After a failover, and when the original active becomes the active again, it would send this temporary file to the CDR server and overwrite the file that had been sent from the previously active system.

The user sets this value using the syntax below.

```
ORACLE(account-config)# cdr-output-redundancy standby-push
```

Setting this value can also enhance the clarity of CDR file names. This would also require that the applicable **account-config** have its **file-seq-number** parameter enabled. The system then includes information within the filename to distinguish whether the file came from the active or standby node. This prevents the standby from overwriting CDRs already on the server. This naming convention adds two prefixes to the CDR filename.

```
XXXX-YYYY-CDR201610171015-000000050
```

- XXXX - The filename-prefix defined in your **push-reciever** setting
- YYYY - The host name of the OCSBC

The **standby-push** value requires that the applicable account-config operate over a management (wancom) interface. Configuration verification fails if the user sets this value to an **account-config** operating over a media interface.

- The

All parameters are RTC supported.

 **Note:**

Before you upgrade from a release prior to S-CZ7.2.0 to S-CZ7.2.0 or later, you must set the **cdr-output-redundancy** parameter to **enabled** for the Standby to upgrade and sync properly. You can then change the parameter to **disabled** afterwards, if needed.

Caveats

As described above, when the system reboots for any reason or when you issue an **activate-config**, the OCSBC checks for CDR files with the **temp-** prefix and renames to the usual **cdrYYYYMMDDHHMM[a-j]** format.

However, if you change the accounting configuration's file-path value and subsequently the system either reboots or you activate your configuration, the OCSBC will be unable to check for files with the **temp-** prefix in the old file path. And so it will also be unable to rename them. The OCSBC checks the new path only.

Temporary Local CDR File Renaming Configuration

To turn off temporary CDR file naming:

1. Access the **account-config** configuration element.

```
ORACLE# configure terminal
ORACLE(configure)# session-router
ORACLE(session-router)# account-config
ORACLE(account-config)#
```

2. Type **select** to begin configuring this object.

3. **options**—Follow your entry with this value:

- **+disable-temp-file**

```
ORACLE(account-config)# options +disable-temp-file
```

This value turns off the temporary CDR file naming the OCSBC, so it does not use the **temp-** prefix for open file. Instead, all files follow the **cdrYYYYMMDDHHMM[a-j]** name format.

To enable temporary CDR file naming, you must use a minus sign (-) before the **disable-temp-file** value.

```
ORACLE(account-config)# options -disable-temp-file
```

4. Type **done** to save your configuration.

Enhanced Stop CDR Reporting for Exceeded Ingress Session Constraints

This release addresses an inconsistency in the generation of RADIUS Stop records when calls are rejected for exceeding configured session ingress or egress constraints. On the egress path, prior releases rejected such calls with a 503 (Service Unavailable) response and the generation of a RADIUS STOP record. On the ingress path, however, while calls were rejected with a 503 response, RADIUS Stop records were not generated.

A new SIP Configuration option (**enhanced-cdr**) enables consistent generation of RADIUS Stop records on both ingress and egress paths. With **enhanced-cdr** enabled, RADIUS Stop records are generated in response to any ingress path rejection of a dialog creating SIP INVITE request. The contents of RADIUS Stop records are also written to Call Detail Records stored on the Oracle Oracle Communications Session Border Controller.

Use the following command syntax to enable more consistent generation of RADIUS Stop records.

This capability is disabled by default.

```
ORACLE(sip-config)# options +enhanced-cdr
ORACLE(sip-config)#
```

3

RADIUS Accounting Management

Overview

This chapter provides information about management and monitoring of RADIUS accounting functions on your OCSBC.

- OCSBC alarm generation and monitoring
- Status and statistics monitoring

Alarm Generation and Monitoring

The products generate alarms when certain hardware and software events occur. For more information about OCSBC alarms for RADIUS, refer to the Maintenance and Troubleshooting Guide.

The RADIUS ACCOUNTING CONNECTION DOWN alarm, detailed in the table below, is directly associated with the OCSBC's RADIUS functionality. When enabled connections to RADIUS servers have timed-out without a response from the RADIUS server, the alarm is activated. The RADIUS ACCOUNTING CONNECTION DOWN alarm triggers a Simple Network Management Protocol (SNMP) trap that is sent via the syslog Management Information Base (MIB) (ap-syslog.mib). For a list of all SNMP-related alarms and their associated traps, refer to the table of SNMP trap correlation to OCSBC's alarms in Oracle's MIB Reference Guide.

This alarm has no impact on a the health score of a OCSBC that is part of an HA Node.

RADIUS Alarms

The table below describes the OCSBC's alarms for RADIUS.

Alarm	Alarm ID	Alarm Severity	Cause	Log Message	Actions
RADIUS ACCOUNTING CONNECTION DOWN	327681	CRITICAL if all enabled and configured RADIUS accounting server connections have timed-out without a response from the RADIUS server. MAJOR if some, but not all configured RADIUS accounting server connections have timed-out without a response from the RADIUS server.	The enabled connections to RADIUS servers have timed-out without a response from the RADIUS server.	CRITICAL: All enabled accounting connections have been lost. Check accounting status for more details. MAJOR: One or more enabled accounting connections have been lost. Check accounting status for more details.	apSyslogMessageGenerated trap generated critical, major dry contact syslog

Status and Statistics Monitoring

The CLI **show radius** command, used with the three arguments described below, displays the status of any established RADIUS accounting connections and authentications. A working RADIUS connection displays READY, and a disabled connection displays DISABLED.

When an accounting server is disabled, the triggering and clearing of RADIUS ACCOUNTING CONNECTION DOWN alarms is not affected.

For more information about OCSBC about monitoring your OCSBC, refer to the Maintenance and Troubleshooting Guide.

CLI Show RADIUS Display

The **show radius** command can take one of the three available arguments:

- authentication—Shows authentication statistics for primary and secondary RADIUS servers, including: server IP address and port; round trip time; information about failed and successful requests/authentications; number of rejections; number of challenges; number of time-outs, number of retransmissions
- accounting—Shows the information described in this table:
 - Client Display—General accounting setup (as established in the accounting configuration element), including information about the state of the RADIUS client, accounting strategy used (Hunt, Failover, RoundRobin, FastestRTT, or FewestPending), IP address and port on which the server is listening, maximum message delay in seconds, and number of configured accounting servers.
 - Waiting Queue—Amount of accounting (RADIUS) messages waiting to be sent. Waiting queue capacity is 4,096 messages.

- <IP Address:Port>—Information about each configured accounting server (established in the accounting servers configuration). The heading above each accounting server section is the IPv4 address and port combination of the accounting server described. This section also includes information about the accounting server's state (e.g., Connect_Attempt, INIT).
- all—Shows all of the information for both the authentication and accounting displays

The following is an example of the ACLI **show radius authentication** command output.

```
ORACLE# show radius authentication
Active Primary Authentication Servers:
  server ipAddr: 172.30.0.7
Active Secondary Authentication Servers:
  server ipAddr: 172.30.0.8
Authentication Statistics:
  Server:"172.30.0.7:1812"
    RoundTripTime           :0
    MalformedAccessResponse:0
    AccessRequests          :2
    BadAuthenticators       :0
    AccessRetransmissions   :5
    AccessAccepts           :0
    Timeouts                :6
    AccessRejects           :0
    UnknownPDUTypes        :0
AccessChallenges           :0
  Server:"172.30.0.8:1812"
    RoundTripTime           :0
    MalformedAccessResponse:0
    AccessRequests          :2
    BadAuthenticators       :0
    AccessRetransmissions   :9
    AccessAccepts           :0
    Timeouts                :10
    AccessRejects           :0
    UnknownPDUTypes        :0
    AccessChallenges        :0
```

The following is an example of the ACLI **show radius accounting** command output.

```
ORACLE# show radius accounting

*****Client Display Start*****
Client State = READY, strategy=Hunt
listening on 127.0.0.1:1813
max message delay = 60 s, # of servers = 2
===== Waiting Queue =====
Waiting size = 89
=====
----- 10.0.0.189:1813 -----
Remote = 10.0.0.189:1813, Local = 0.0.0.0:1026, sock=45 (BOUND)
conn state=READY, RTT=250 ms
Min Rtt=250 ms, Max inactivity=60 s, expires at Nov 21 13:50:19.582,
```

```
Restart delay=30 s
----- 192.168.200.70:5050 -----
Remote = 192.168.200.70:5050, Local = 0.0.0.0:1027, sock=46 (BOUND)
conn state=DISABLED, RTT=0 ms
Min Rtt=250 ms, Max inactivity=60 s, expires at Nov 21 13:50:19.569,
Restart delay=30 s
*****Client Display End*****
```

The following is an example of the ACLI **show radius all** command output.

```
ORACLE# show radius all
*****Client Display Start*****
Client State = READY, strategy=Hunt
listening on 127.0.0.1:1813
max message delay = 60 s, # of servers = 2
===== Waiting Queue =====
Waiting size = 89
=====
----- 10.0.0.189:1813 -----
Remote = 10.0.0.189:1813, Local = 0.0.0.0:1026, sock=45 (BOUND)
conn state=READY, RTT=250 ms
Min Rtt=250 ms, Max inactivity=60 s, expires at Nov 21 13:50:19.582,
Restart delay=30 s
----- 192.168.200.70:5050 -----
Remote = 192.168.200.70:5050, Local = 0.0.0.0:1027, sock=46 (BOUND)
conn state=DISABLED, RTT=0 ms
Min Rtt=250 ms, Max inactivity=60 s, expires at Nov 21 13:50:19.569,
Restart delay=30 s
*****Client Display End*****
Active Primary Authentication Servers:
  server ipAddr: 172.30.0.7
Active Secondary Authentication Servers:
  server ipAddr: 172.30.0.8
Authentication Statistics:
  Server:"172.30.0.7:1812"
    RoundTripTime           :0
    MalformedAccessResponse:0
    AccessRequests          :2
    BadAuthenticators       :0
    AccessRetransmissions   :5
    AccessAccepts           :0
    Timeouts                 :6
    AccessRejects           :0
    UnknownPDUTypes        :0
AccessChallenges           :0
  Server:"172.30.0.8:1812"
    RoundTripTime           :0
    MalformedAccessResponse:0
    AccessRequests          :2
    BadAuthenticators       :0
    AccessRetransmissions   :9
    AccessAccepts           :0
    Timeouts                 :10
    AccessRejects           :0
```

```
UnknownPDUTypes      :0
AccessChallenges     :0
```

Monitoring CDR Push Receivers

You can use the CLI **show radius cdr** command to view information about CDR push receivers. The existing display for this command has been extended to include information that looks like the following:

```
***** CDR Push Receiver Display Start*****
strategy = FastestRTT, maxwaitfailover = 10, number of receivers = 1
----- 172.30.0.70:21 -----
cdrpush-receiver = 172.30.0.70:21, state = READY, priority = 4
remote path = /home/acme, remote prefix = vik, protocol = ftp
username = acme, password = *****, publickey =
FTP rtt = 0, FTP successes = 0, FTP failures = 0
FTP timeouts = 0, FTP Delays = 0, FTP Put failures = 0
FTP conn failures = 0, FTP terminates = 0, FTP triggered terminates = 0
```

SNMP Support

The OCSBC sends traps when a single push receiver or all push receivers become unavailable.

- When one CDR push receiver becomes unavailable, the CDR_PUSH_RECEIVER_FAIL_TRAP trap is sent and a minor alarm is generated.
- When all of the configured CDR push receivers become unavailable, the CDR_ALL_PUSH_RECEIVERS_FAIL_TRAP is sent and a major alarm is generated.

When one or more of the push receivers comes back, the CDR_ALL_PUSH_RECEIVERS_FAIL_CLEAR_TRAP is sent and the alarm is cleared.

CDR File Transfer Failure Alarm

The OCSBC sends out traps and triggers corresponding alarms when it encounters failure when attempting to transfer locally stored CDR files via FTP or SFTP. One set of traps is used for instances when one CDR push receiver fails; another is used when all enabled CDR receivers fail. They are part of the apSysMgmtCDRPushReceiverNotificationsGroup.

All of the traps contain information about the type of push receiver, the address of the push receiver, and the failure reason code.

All of the traps contain information about the type of push receiver, the address of the push receiver, and the failure reason code.

The trap and corresponding clearing trap for single push receiver failure are:

- apSysMgmtCDRPushReceiverFailureTrap
- apSysMgmtCDRPushReceiverFailureClearTrap

The trap and corresponding clearing trap for global push receiver failure are:

- apSysMgmtCDRAIPushReceiversFailureTrap
- apSysMgmtCDRAIPushReceiverFailuresClearTrap

4

Storage Expansion Module

Storage Expansion Module Use With Local CDRs FTP Push

The AcmePacket suite of engineered systems can be configured with an optional Storage Expansion Module that extends the system's internal storage beyond the fixed amount of flash RAM. When configuring local CDR creation, you can configure the OCSBC to use the Storage Expansion Module for local CDR files instead of the limited internal flash RAM.

Disk space on the Storage Expansion Module appears as a local volume on the OCSBC. Wherever you specify a volume name for a configuration parameter value, you can enter a volume located on the Storage Expansion Module, (unless the parameter is otherwise specified).

Local CDR Storage Directory

To save local CDR files to the Storage Expansion Module, configure the **file path** parameter in the account config with a volume and directory located on the Storage Expansion Module.

FTP Push Backup

When FTP push is enabled, if all FTP push servers are unreachable, then local CDR files are written to local file system until the FTP push servers return to service. Once an FTP Push server becomes reachable, the OCSBC transfers all local CDR files to the remote server automatically. After all local CDR files have been successfully transferred to the FTP server from the OCSBC, they are deleted from the local volume.

Local CDR File Compression

You can configure the OCSBC to compress local CDRs in zip format to save disk space. The local CDRs will be compressed and appear with a .zip file extension. This feature is enabled with the **cdr compression** parameter.

ACLI Configuration and Examples

The following ACLI configuration procedure describes:

- identifying volumes on the Storage Expansion Module
- configuring Storage Expansion Module volumes as the destination for local CDR files

These procedures are only a portion of local CDR file generation and FTP Push configuration. Please refer to the Local CDR Storage and FTP Push section for a full explanation and all prerequisites before referencing the following procedure.

Identify Volumes

To identify the volumes on the Storage Expansion Module to use with local CDR storage:

- Note the volume name on the Storage Expansion Module you wish to use for local CDR output using the **show space hard-disk** command.

```
SYSTEM# show space hard-disk
/opt: 19695716352/19695749120 bytes (99%) remaining
/opt/logs: 19693335040/19693367808 bytes (99%) remaining
SYSTEM#
```

 **Note:**

The check-space-remaining hard-disk command is identical to the show space hard-disk command.

Configure File Path

To configure an Oracle Communications Session Border Controller to write local CDRs to the Storage Expansion Module:

1. In Superuser mode, type **configure terminal** and press Enter.

```
ORACLE# configure terminal
```

2. Type **session-router** and press Enter.

```
ORACLE(configure)# session-router
```

3. Type **account-config** and press Enter.

```
ORACLE(session-router)# account-config
ORACLE(account-config)#
```

4. **file-path**—Set this parameter to the volume you identified to use for local CDR file storage in the previous section. Ensure the path begins with a forward slash, /.
5. Save and activate your configuration.

Storage Expansion Module Management

The OCSBC provides you with a set of tools to manage the Storage Expansion Module.

See the Maintenance and Troubleshooting Guide's File System Maintenance chapter for more information.

Storage Expansion Module Monitoring

Low Disk Space Warning

The OCSBC can initiate an alarm and an SNMP trap when a volume reaches a configured threshold of remaining free disk space, configured as a percentage of volume. You can configure multiple alarms, each with increasing severity that indicate less free disk space.

Low Disk Space Threshold Alarm

The low disk space threshold alarm is configured in **alarm threshold** configuration element. It is non-health affecting. The threshold alarm appears as follows:

```
SYSTEM# display-alarms
1 alarms to show
ID      Task      Severity      First Occurred      Last Occurred
131142  547896076    4             2009-08-25 13:36:26         2009-08-25
13:36:26
Count   Description
1       Volume /misc space used 81% is over major threshold of 80%.
```

Low Disk Space Threshold SNMP Trap

For any threshold reached, an SNMP trap will be sent to all configured trap-receivers. The apSysMgmtStorageSpaceAvailThresholdTrap trap contains the following information:

- VolumeName—name of the volume where a threshold was exceeded
- CurrentValue—current percentage of disk space value that is exceeding one of the thresholds.
- MinorThreshold—configured minor threshold for this volume, if none then this is 0.
- MajorThreshold—configured major threshold for this volume, if none then this is 0.
- CriticalThreshold—configured critical threshold for this volume, if none then this is 0.

ACLI Configuration and Examples

To configure alarm thresholds for monitoring free disk space:

1. In Superuser mode, type **configure terminal** and press Enter.

```
ORACLE# configure terminal
```

2. Type **system** and press Enter.

```
ORACLE(configure)# system
ORACLE(system)#
```

3. Type **system-config** and press Enter.

```
ORACLE(system)# system-config
ORACLE(system-config)#
```

4. Type **select** and press Enter.

```
ORACLE(system-config)# select
ORACLE(system-config)#
```

5. Type **alarm-threshold** and press Enter.

```
ORACLE(system-config)# alarm-threshold
ORACLE(alarm-threshold)#
```

The system prompt changes to let you know that you can begin configuring individual parameters.

6. **type**—Set this parameter to **space** to create an alarm based on reduced free disk space.
7. **volume**—Set this parameter to the volume name you wish to monitor. Generally this string should be the same as the **file-path** parameter located in the account-config.
8. **severity**—Enter the severity level of this alarm. Valid severity values are MINOR, MAJOR, and CRITICAL.
9. **value**—Enter the percent of resource (type) in use that triggers the configured alarm (severity).
10. Save your work.
11. Repeat this procedure to configure multiple alarm thresholds.

The following example reflects what a major and critical alarm would look like:

```
alarm-threshold
    type           space
    volume         /opt
    severity       major
    value          80
alarm-threshold
    type           space
    volume         /misc
    severity       critical
    value          90
```

Local CDR File Delete Warning

You can configure the OCSBC to initiate an alarm and send an SNMP trap when the oldest local CDR file was deleted under fault conditions. This feature is enabled with the **file delete alarm** parameter.

The OCSBC deletes a local CDR file in the following three cases:

1. After the local CDR file has been successfully transferred to a push receiver

2. The number of local CDR files exceed the limit configured in the **account-config, max-files** parameter
3. No free disk space remains on the partition where the local CDR files are written: **account-config, file-path**

If a local CDR file is deleted after it was successfully uploaded to a push receiver, no fault is triggered because this is standard, expected operation. But if a local CDR file is deleted for case 2 or 3 above, it is considered a fault condition initiating an alarm and SNMP trap.

Local CDR File Delete Alarm

The CDR file delete alarm is configured in **account config** configuration element by enabling the **file-delete-alarm** parameter. This is a minor severity alarm and is non-health affecting. This alarm has no clearing condition and must be manually cleared.

Local CDR File Delete SNMP Trap

Under the same circumstances that cause a CDR file delete alarm, an SNMP trap will be sent to all configured trap-receivers. The `apSysMgmtCdrFileDeleteTrap` trap contains the following information:

- File Name—name of the file that was deleted

Querying Storage Space

You can monitor currently used and remaining storage space on the Storage Expansion Module by ACLI, SNMP MIB, and HDR collection group.

ACLI

To view the total disk space used percentage remaining with the ACLI, use the **show space hard-drive** command. For example:

```
SYSTEM# show space hard-disk
/sys: 19695716352/19695749120 bytes (99%) remaining
/local: 19693335040/19693367808 bytes (99%) remaining
/logs: 19693335040/19693367808 bytes (99%) remaining
/misc: 19693335040/19693367808 bytes (99%) remaining
SYSTEM#
```

Note:

The `check-space-remaining hard-disk` command is identical to the `show space hard-disk` command.

Unmounting The Storage Expansion Module

This section explains the ACLI **unmount hard-disk** command, which—as its name indicates—unmounts the storage expansion module. This command should only be run when you plan to shut down the system. You issue this command to ensure

the integrity of the disk when you power off the Oracle Communications Session Border Controller using the power switch. If you do not run the command and use the power switch to power down the system, the Oracle Communications Session Border Controller runs a checkdisk on the module the next time the system boots. The checkdisk lasts one to two minutes.

Note that once you run the **unmount hard-disk** command, any application configuration set to use a module partition will no longer work. The only way to regain access is to reboot or power cycle the system.

ACLI Instructions and Examples

To ensure the storage expansion module's integrity when powering down the system (using the power switch), use the **unmount hard-disk** command:

```
ORACLE# unmount hard-disk
```

SNMP MIB

The following MIB Objects are available to query the amount of remaining drive space.

Name	OID	MIB	Description
apSysStorageSpaceTable	1.3.6.1.4.1.9148.3.2.1.1.23	APSYSMGMT-MIB	The total percentage space available on the drive/partitions.

```

apSysStorageSpaceTable          OBJECT-TYPE
    SYNTAX                       SEQUENCE OF ApSysStorageSpaceEntry
    MAX-ACCESS                     not-accessible
    STATUS                         current
    DESCRIPTION
        "A table to hold the total space and available space
        per volume arranged into rows, and indexed by the
        volume name.
        These are all read only."
    ::= { apSysMgmtMIBGeneralObjects 23 }
apSysStorageSpaceEntry          OBJECT-TYPE
    SYNTAX                       ApSysStorageSpaceEntry
    MAX-ACCESS                     not-accessible
    STATUS                         current
    DESCRIPTION
        "A table entry designed to hold storage space data, on a
        single volume"
    INDEX { apSysVolumeName }
    ::= { apSysStorageSpaceTable 1 }
ApSysStorageSpaceEntry ::= SEQUENCE {
    apSysVolumeName                DisplayString,
    apSysVolumeTotalSpace          Unsigned32,
    apSysVolumeAvailSpace          Unsigned32,
}
apSysVolumeName                 OBJECT-TYPE
    SYNTAX                       DisplayString (SIZE (0..255))
    MAX-ACCESS                     read-only
    STATUS                         obsolete

```

```

        DESCRIPTION
            "The name of the volume"
        ::= {apSysStorageSpaceEntry 1}
apSysVolumeTotalSpace      OBJECT-TYPE
        SYNTAX                Unsigned32
        MAX-ACCESS            read-only
        STATUS                 obsolete
        DESCRIPTION
            "The total size of the volume, in bytes"
        ::= {apSysStorageSpaceEntry 2}
apSysVolumeAvailSpace      OBJECT-TYPE
        SYNTAX                Unsigned32
        MAX-ACCESS            read-only
        STATUS                 obsolete
        DESCRIPTION
            "The total space available on the volume, in bytes"
        ::= {apSysStorageSpaceEntry 3}

```

HDR

Historical Data Record statistics are available that track the amount of storage space available on each Storage Expansion Module partition. At each collect interval, space consumption statistics are gathered for every partition. The Storage Space collect group, configured as **space**, contains these statistics. The contents of this Storage Space group are:

- TimeStamp
- Partition
- Space used
- Space available

5

Diameter Rf Accounting

Diameter Accounting

The OCSBC supports the Diameter charging interface, Rf. This interface provides similar functionality to the RADIUS interface, but utilizes Diameter as the underlying application layer protocol. As a result, the OCSBC can integrate more thoroughly with IMS standards as well as provide a more dynamic, secure, and robust accounting interface.

Diameter Accounting Messages

The Rf interface can send messages based on the signaling application's actions. These messages are Accounting Charging Request (ACR) Start messages, ACR Stop messages, Event messages and Interim messages.

Resending ACRs

- If an ACA is not received to acknowledge the reception of an ACR, the OCSBC attempts to resend an ACR and buffers all subsequent ACRs for the same session until the acknowledgement is received. Once the acknowledgement is received from the CCF, all buffered ACRs for that same session may be sent to the CCF in the appropriate order. If the OCSBC does not receive the ACA after the user-specified number of retries, then the OCSBC sends all of the buffered ACR records for a session to the secondary CCF. (The number of ACR retries as well as the wait time in between retries is configurable by using the max-acr-retries account configuration parameters and acr-retry-interval, respectively.)

Postponement Feature

- Any number of ACRs can be sent during a session, including Start, Stop, Interim and ACR messages. The ACR postponement feature (non-configurable) ensures that the next ACR is not sent until the previous ACR is acknowledged with an ACA.

Call Flow Examples

- The following call flow example shows success in receiving an ACA for a session after resending the ACR message three times.

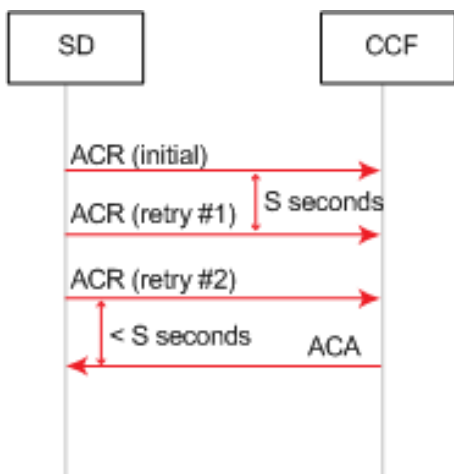

Successful ACA Acknowledgement After Three Retries

The following call flow example shows the failure to receive an ACA for a session after sending the ACR message three times.



Unsuccessful ACA Acknowledgement After Three Retries

The following call flow example shows how the delay of the ACA acknowledgement for a session results in a postponement until the ACA is finally received. During the postponement, the ACRs are buffered until the corresponding ACA is received. If an ACR for one session is postponed, it does not delay the other session's ACRs.

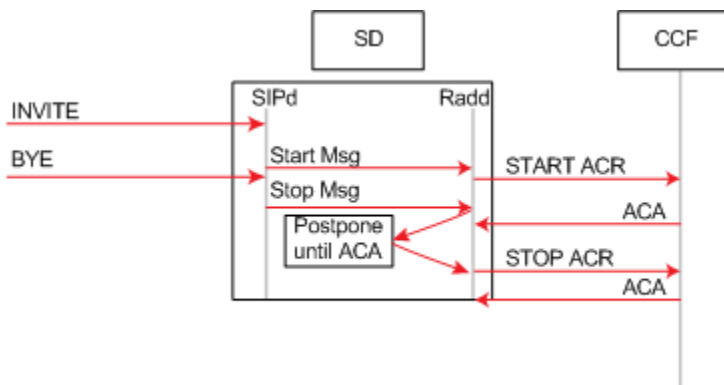

Call Flow Showing Delivery Postponement

- Additional ACR Interim messages are sent when service changes; this roughly maps to a RADIUS Interim-Update message. See [Accounting-Record-Type AVP \(480\)](#).
- ACR Stop messages are sent at the end of service delivery.

The OCSBC sends a set of AVPs in each ACR start and stop message that make up the charging data. The following table lists which AVPs are included in ACR Start and ACR Stop messages. Individual AVP descriptions are located in the following section.

AVP	ACR Start	ACR Stop
Session-Id AVP (263)	X	X
Origin-Host AVP (264)	X	X
Origin-Realm AVP (296)	X	X
Destination-Realm AVP (283)	X	X
Destination-Host AVP (293)	X	X
Accounting-Record-Type AVP (480)	X	X
Accounting-Record-Number AVP (485)	X	X
Acct-Application-Id AVP (259)	X	X
User-Name AVP (1)	X	X
Event-Timestamp AVP (55)	X	X
Event-Type AVP (823)	X	X
SIP-Method AVP (824)		
Content-Type AVP (826)		
Content-Length AVP (827)		
Role-of-Node AVP (829)	X	X
User-Session-Id AVP (830)	X	X
Calling-Party-Address AVP (831)	X	N/A
Called-Party-Address AVP (832)	X	N/A
Time-Stamps AVP (833)	X	X
SIP-Request-Timestamp AVP (834)		
SIP-Response-Timestamp AVP (835)		
Inter-Operator-Identifier AVP (838)	X	X
Originating-IOI AVP (839)		
Terminated-IOI AVP (840)		
SDP-Session-Description AVP (842)	X	N/A
Session-Media-Component AVP (845)	X	N/A
SDP-Media-Name AVP (844)		
SDP-Media-Description AVP (845)		
Cause AVP (860)	N/A	X
Cause-Code AVP (861)		
Node-Functionality AVP (862)		

ACR AVP Descriptions

This section provides individual AVP descriptions.

Session-Id AVP (263)

Uniquely identifies this session. It is a string value and is delimited by semi-colons. This AVP is created according to the Session-Id AVP (AVP Code 263) specified in IETF RFC 3588. An example of a Session-Id from the OCSBC is as follows, `acmesystem;0;1`.

Origin-Host AVP (264)

Contains the account-server configuration element's **hostname** parameter followed by the "@" character, followed by the account-server configuration element's **origin-realm** parameter. For example: `acmesystem@wancom.com`.

Origin-Realm AVP (296)

Contains the **account server** configuration element's **origin-realm** and **domain-name-suffix** parameters where the server request is sent.

Destination-Realm AVP (283)

Contains the value of the Origin-Realm AVP in the CEA received from the accounting server for this connection.

Destination-Host AVP (293)

Contains the value of the Origin-Host AVP in the CEA received from the accounting server for this connection.

Accounting-Record-Type AVP (480)

Contains the value indicating the type of accounting message being sent.

- event record = 1
- start record = 2
- interim record = 3
- stop record = 4

Accounting-Record-Number AVP (485)

A value that uniquely identifies this message in the session (i.e., a sequence number for this connection). The sequence number is assigned sequentially starting with 0 as described below. This is compliant with RFC 3588. The combination of the Accounting-Record-Number AVP and the Session-Id AVP (both of which are unique for the given session) are used to match accounting records with confirmations. This is done by assigning the noted values to the records listed below:

- Event Record — the system assigns this record a value of 0 to this record.
- Start Record — the system assigns this record a value of 0 to this record.
- Interim Record — the system assigns this record a value of 1 to the first record of this type for the session, and increments the value by 1 for each

subsequent Interim_record until the value for the Stop_record is more for the last Interim_record for the session.

- Stop Record — (see description for Interim_record in the previous bullet) — If there is no Interim_record for the session, the system assigns a value to this record of 1.

The following example call flow shows a Register Event that shows that the Event record in the Accounting-Record-Number AVP is always populated with 0.

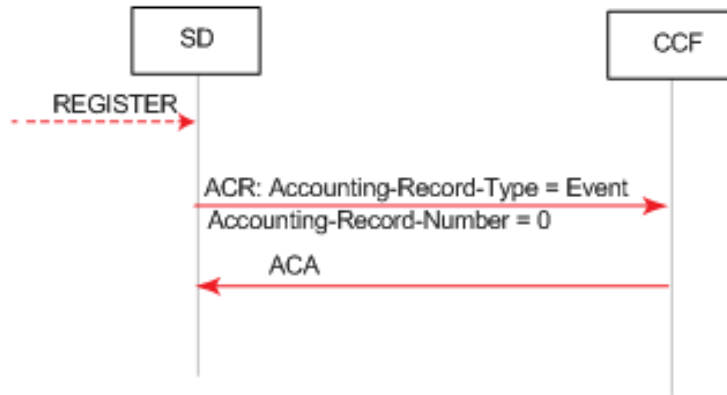

Register Event Call Flow Example

The following example call flow shows session accounting messages with no Interim records. Note that the Start Accounting-Record-Number equals 0 and the Stop Accounting-Record-Number equals 1.

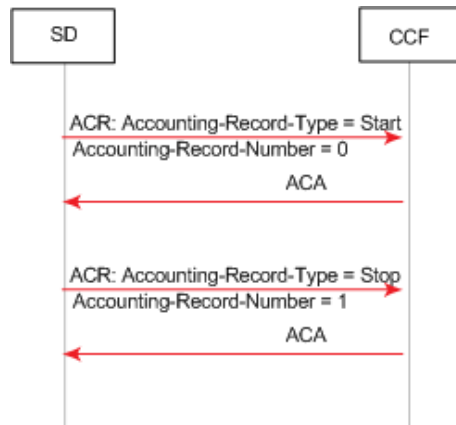

Call Flow Example Showing Session Accounting Messages with No Interim Records

The following example call flow shows session accounting messages with Interim records. Note that the Start record Accounting-Record-Number equals 0 and that the Interim Accounting-Record-Numbers start with a value of 1 and increase by 1 with the second Interim record. The Stop Accounting-Record-Number equals 3.

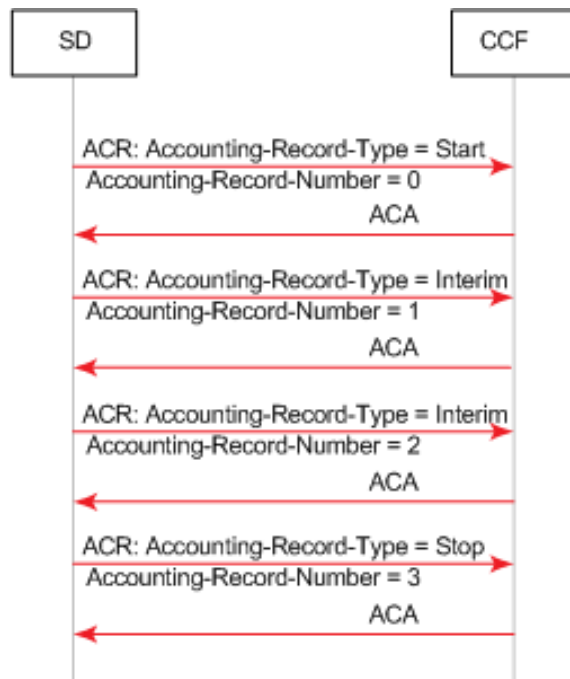

Call Flow Example Showing Session Accounting Messages with Interim Records

Acct-Application-Id AVP (259)

Set to value "3". This value indicates Diameter-based accounting messages.

User-Name AVP (1)

Contains the account-server configuration element's hostname parameter followed by the "@" character, followed by the account-server configuration element's origin-realms parameter. For example: acmesystem@wancom.com.

Event-Timestamp AVP (55)

Contains the number of seconds since January 1, 1900 when this accounting event took place.

Event-Type AVP (823)

A grouped AVP containing information about the signaling event. It contains the following AVPs:

- SIP-Method AVP (824)—Contains the exact string payload from the SIP request line; i.e., the Method that triggered the accounting event.
- Content-Type AVP (826)—Contains the exact string payload from the "Content-Type" SIP header of the message that triggered the accounting event.
- Content-Length AVP (827)—Contains the exact string payload from the Content-Length SIP header of the message that triggered the accounting event.

Role-of-Node AVP (829)

Set to the value 2 which indicates that the OCSBC is operating in a PROXY role.

User-Session-Id AVP (830)

Contains VSA 44 as used in the RADIUS interface.

Calling-Party-Address AVP (831)

The Calling-Party-Address AVP (AVP code 831) is of type UTF8String and holds the address (SIP URI or TEL URI) which identifies the party (Public User Identity or Public Service Identity) initiating a SIP transaction. It is obtained from the P-Asserted-Identity header of any non-REGISTER SIP Request, either initiating a dialog or a standalone transaction. This AVP may appear several times when the P-Asserted-Identity header contains both a SIP URI and a TEL URI. In case no P-Asserted-Identity is known, this AVP list shall include one item with the value "unknown".

Called-Party-Address AVP (832)

The Called-Party-Address AVP (AVP code 832) is of type UTF8String. In IMS charging (except for SIP Register and SIP Subscription transactions), it holds the address (SIP URI, TEL URI or URN) of the party (Public User ID or Public Service ID) to whom the SIP transaction is posted. The Called Party Address shall be populated with the SIP URI or TEL URI contained in the Request-URI of the outgoing request.

For a registration procedure, this field holds the party (Public User ID) to be registered. In this case, the Called Party Address field is obtained from the To SIP header of the SIP Request. For a subscription procedure this field holds the address of the resource for which the originator wants to receive notifications of change of states. In this case, the Called Party Address field is obtained from the outgoing Request-URI of the SIP Request.

Time-Stamps AVP (833)

A grouped AVP that contains timestamps for the related SIP signaling. It contains the following AVPs.

- SIP-Request-Timestamp AVP (834)—A UTC formatted timestamp that corresponds to when the SIP INVITE that started the session was received.
- SIP-Response-Timestamp AVP (835)—A UTC formatted timestamp that corresponds to when the SIP 200 OK response to the INVITE that started the session was received.

Inter-Operator-Identifier AVP (838)

A grouped AVP that indicates the ingress and egress networks from the OCSBC's perspective. It contains the following AVPs.

- Originating-IOI AVP (839)—The realm where the OCSBC received the SIP signaling messages.
- Terminated-IOI AVP (840)—The realm where the SIP signaling message exit the OCSBC.

SDP-Session-Description AVP (842)

This AVP may occur multiple times in an ACR message. It is populated with SDP attribute-lines from the SIP messages to which this ACR Stop message refers. Thus, all "i=", "c=", "b=", "k=", "a=", etc..., lines comprise multiple instances of this AVP.

If the OCSBC is configured to generate Start events on the INVITE, the calling SDP will be used; if the OCSBC is configured to generate Start events on the OK, the called SDP will be used. ONLY IN ACR Start.

Session-Media-Component AVP (845)

A grouped AVP that contains information about the media session. It contains the following AVPs. ONLY IN ACR Start.

- SDP-Media-Name AVP (844)—populated with the "m=" line from the SDP being used.
- SDP-Media-Description AVP (845)—this AVP may occur multiple times in this grouped AVP. It is populated with SDP attribute-lines from the media component as specified by the media described in the SDP-Media-Name AVP. Thus, all "i=", "c=", "b=", "k=", "a=", etc..., lines related to the above specified "m=" line comprise multiple instances of this AVP.

Cause AVP (860)

A grouped AVP that contains the reason for the termination event and the role/function of the node where the call was terminated. It contains the following AVPs.

- Cause-Code AVP (861)—See Values for Cause Code AVP (861) below.
- Node-Functionality AVP (862)—Set to value 0.

Values for Cause Code AVP (861)

As described in 3GPP TS32.229, the Cause-Code AVP 861 includes the cause code value sent by the IMS node. It is used in stop and/or event messages.

If the session terminated as a result of a specific known SIP error code, the SIP error code is used as the cause code value. Otherwise, cause code values less than or equal to 0 are used for successful causes while values greater than or equal to 1 are used for failure causes.

- Cause code value set to 0 — indicates "Normal end of session" and is used in Accounting-request[stop] message to indicate that an ongoing SIP session has been normally released either by the user or by the network (SIP BYE message initiated by the user or initiated by the network has been received by the IMS node after the reception of the SIP ACK message).
- Cause code value set to "2xx Final Response" (except 200) — used when the SIP transaction is terminated due to an IMS node receiving/initiating a 2xx Final response.
- Cause code value set to "2xx Final Redirection"— used when the SIP transaction is terminated due to an IMS node receiving/initiating a 3xx response.

- Cause code value set to "1"— indicates "Unspecified error" and is used when the SIP transaction is terminated due to an unknown error.
- Cause code value set to "4xx Request failure"— used when the SIP transaction is terminated due to an IMS node receiving/initiating a 4xx error response.
- Cause code value set to "5xx Server failure"— used when the SIP transaction is terminated due to an IMS node receiving/initiating a 5xx error response.
- Cause code value set to "6xx Global failure"— used when the SIP transaction is terminated due to an IMS node receiving/initiating a 6xx error response.
- Cause code value set to "Unsuccessful session setup"— used in the Accounting-request[stop] when the SIP session has not been successfully established (i.e. Timer H expires and SIP ACK is not received or SIP BYE is received after reception of the 200OK final response and SIP ACK is not received).
- Cause code value set to "Internal error"— used when the SIP transaction is terminated due to an IMS node internal error (e.g. error in processing a request/response).

ACR Event Records

The OCSBC supports ACR [Event] records, according to 3GPP TS 32.260. This is in addition to start, stop and interim records. These records reflect a preset type of SIP event. The ACRs are then sent to the CCF.

The OCSBC can create Event ACR messages on REGISTER and/or local-re-REGISTER requests. A local re-register is when registration caching is enabled and the REGISTER from an currently registered endpoint occurs before half of the registration expiration time. In such cases the OCSBC sends a 200 OK to the re-registering endpoint and does not forward the re-REGISTER to the registrar.

Event record creation is enabled with the **generate-event** parameter in the account config. This parameter can be set to register, local-register or both values. The configured value indicates the type of message that initiates an event ACR message sent to a CCF. Register only prompts the OCSBC to create Event ACRs at a REGISTER, local-register prompts the OCSBC to create Event ACRs on a re-REGISTER that was replied to by the OCSBC.

Event messages are created when the OCSBC receives a SIP Final Response 2xx or SIP Final Response (4xx or 5xx), that indicates an unsuccessful REGISTER.

Event ACR messages are also generated to indicate there has been an unsuccessful session attempt. Upon receiving a 4xx, 5xx or 6xx response to a SIP Invite, an Event message is created.

ACR Event Message Construction

An Event ACR is generated according to the tables that describe the AVPs present in the OCSBC's ACR message. Refer to the checked items in the Event column to see all included AVPs. Note that the Accounting-Record-Type AVP (480) is set to Event_Record (1).

Event-Type AVP

The Event-Type AVP (AVP code 823) is a Grouped AVP and contains information about the type of chargeable telecommunication service/event for which the accounting-request and/or credit control request message(s) is generated.

It is used in an AAR Event record. In this context, refer to the following:

AVP	Number	Acme #	Definition
[SIP-Method]	824	173	Contains the name of the SIP Method (this will be REGISTER) causing a accounting request to be sent to the CCF.
[Event]	825	245	Holds the content of the "Event:" header. This is not present in a REGISTER or re-REGISTER message
[Expires]	888	246	Holds the content of the "Expires" header. Upon a re-REGISTER this value is the time remaining until the endpoint's registration expires.

Expires Value

A refresher on the expires value: If the Contacts: header does not contain an expires parameter, the OCSBC adds one with the value in the Expires: header in the 200 OK returned to the UA who sent the INVITE. If there is no Expires: header, the OCSBC adds expires parameter with a value of 3600 and an Expires header with a value of 3600 to the 200 OK.

As the OCSBC forwards the final 200 OK to the initiating endpoint, the Expires (888) AVP contains the largest expires value of all expires parameters in Contact: headers.

When registration caching is enabled and the OCSBC receives a reREGISTER from an endpoint before the halftime of the local registration has expired, the OCSBC inserts the maximum of all associates contacts' remaining time until expiry in the Expires AVP.

Event ACRs Generated for Unsuccessful Session Attempts

When any of the following responses are received in response to a SIP Invite, an Event ACR message is created to indicate there has been an unsuccessful session attempt:

- 4xx Request Failure Code — this code is used when the SIP transaction is terminated due to an IMS node receiving a 4xx error response.
- 5xx Server Failure Code — this code is used when the SIP transaction is terminated due to an IMS node receiving a 5xx error response.
- 6xx Global Failure Code — this code is used when the SIP transaction is terminated due to an IMS node receiving a 6xx error response.

This example call flow shows how a 5xx server failure results in the sending of an Event ACR.

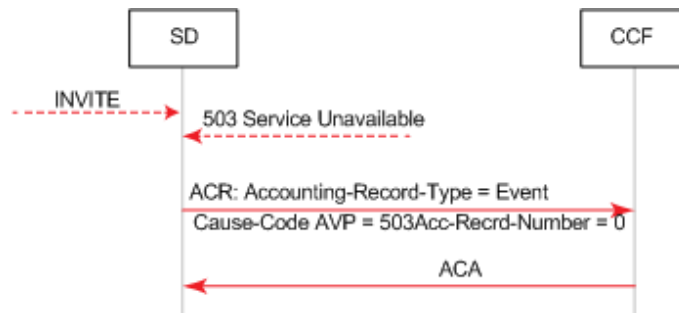

Call Flow Example Showing Event ACR Generation Due to 5xx Server Failure

The following call flow example shows two session agents. The first session agent replies with 503, which results in an Event ACR with cause code 503. The second session agent replies with 200OK that causes the sending of a Start ACR. The generate-start parameter is OK.

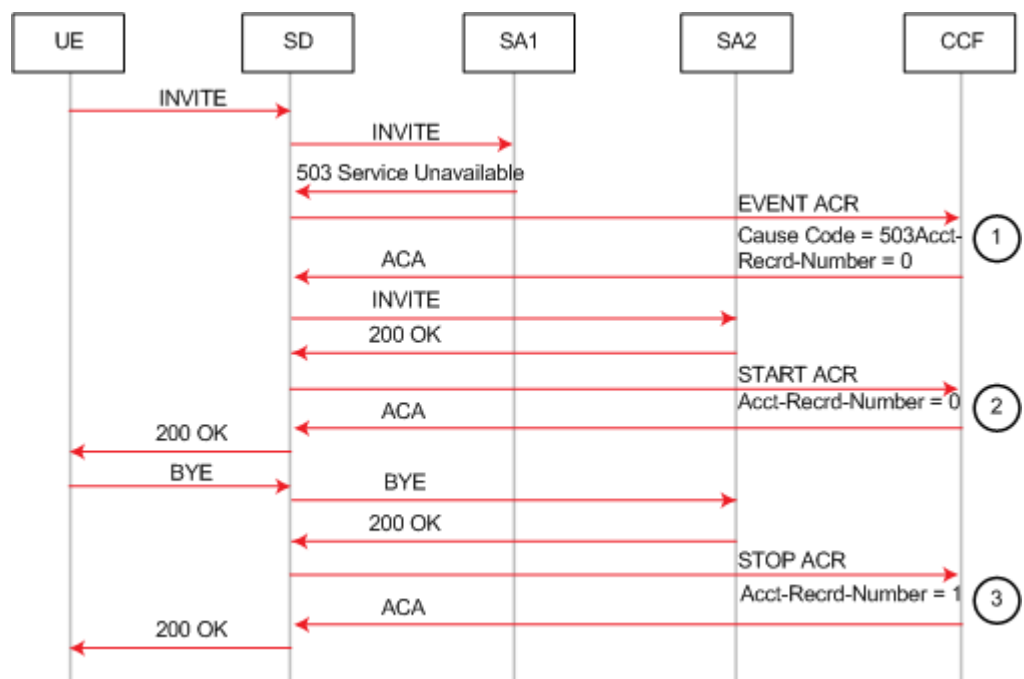

Call Flow Example Showing Sending of an Event and Start ACR

This example call flow illustrates the same call flow when generate-start are equal to Invite. In this case, Start, Interim and Stop ACRs are sent. The generate-start parameter is OK.

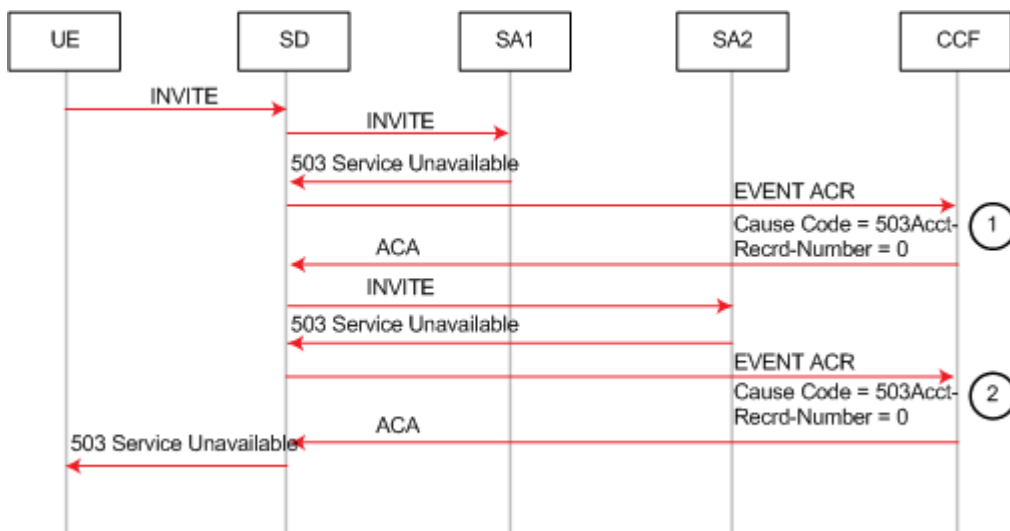

Call Flow Example Showing Generation of Event ACRs Due to 5xx Server Failures

This example call flow shows how a session is created and a Start ACR is sent but then a 5xx server failure occurs that results in sending an Interim ACR. The generate-start parameter is Invite.

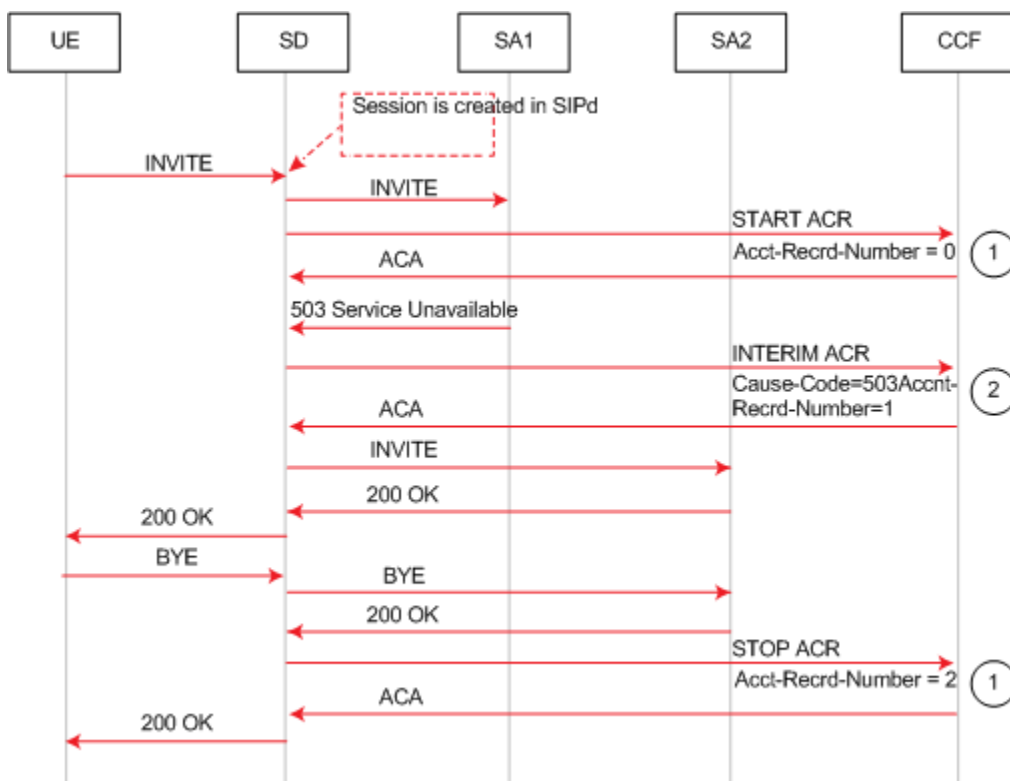

Call Flow Example Showing Sending of Start and Interim ACRs

This example call flow shows how the SD rejects a call before a session is created. When the enhanced-cdr option is not set, an Event ACR is then sent.

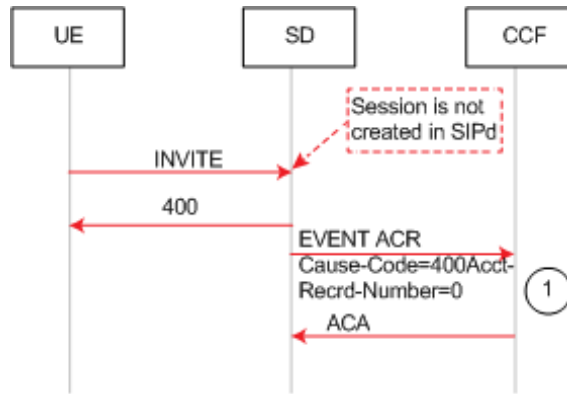

Call Flow Example Showing Unsuccessful Session Creation and Sending of a Event ACR

Event ACRs Generated for Receipt of SIP Messages

An Event ACR is issued when the following SIP messages are received:

- 200 OK message for a SIP Register from the IMS core.
- SIP Final/Redirection Response 3xx
- SIP Final Response (4xx, 5xx or 6xx) — this indicates an unsuccessful session-unrelated procedure.
- SIP Final Response (4xx, 5xx or 6xx) — this indicates an unsuccessful SIP session set-up.

This example call flow shows an Event ACR that is created due to the reception of a 3xx SIP message. In this example the call fails after being redirected.

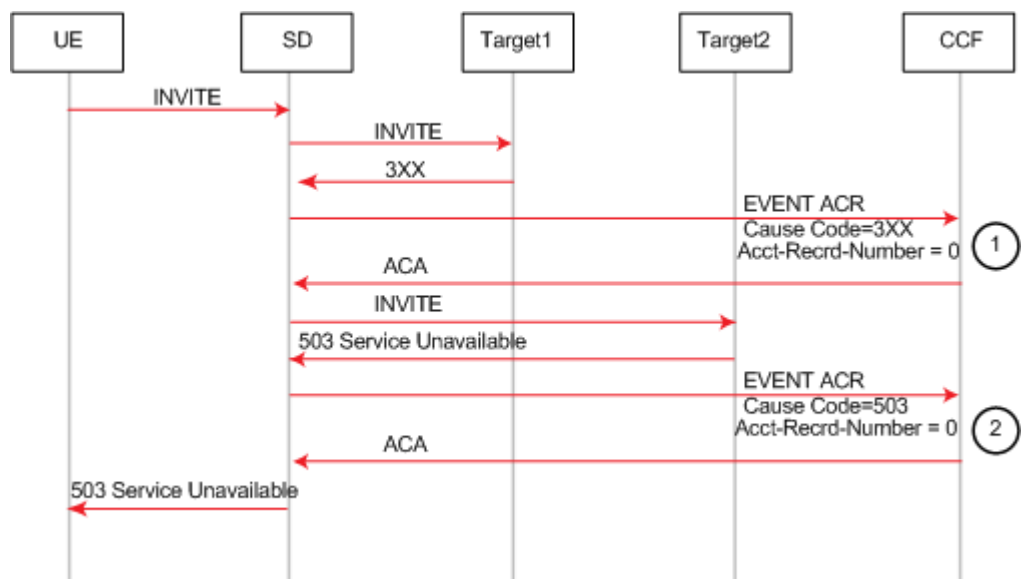

Event ACR Created Upon Reception of a 3xx Message Followed by Call Failure After Redirect

This example call flow shows an Event ACR that is created due to the reception of a 3xx SIP message. Then it shows a Start ACR upon reception of a 200OK. In this example the call succeeds after being redirected. The generate-start is OK.

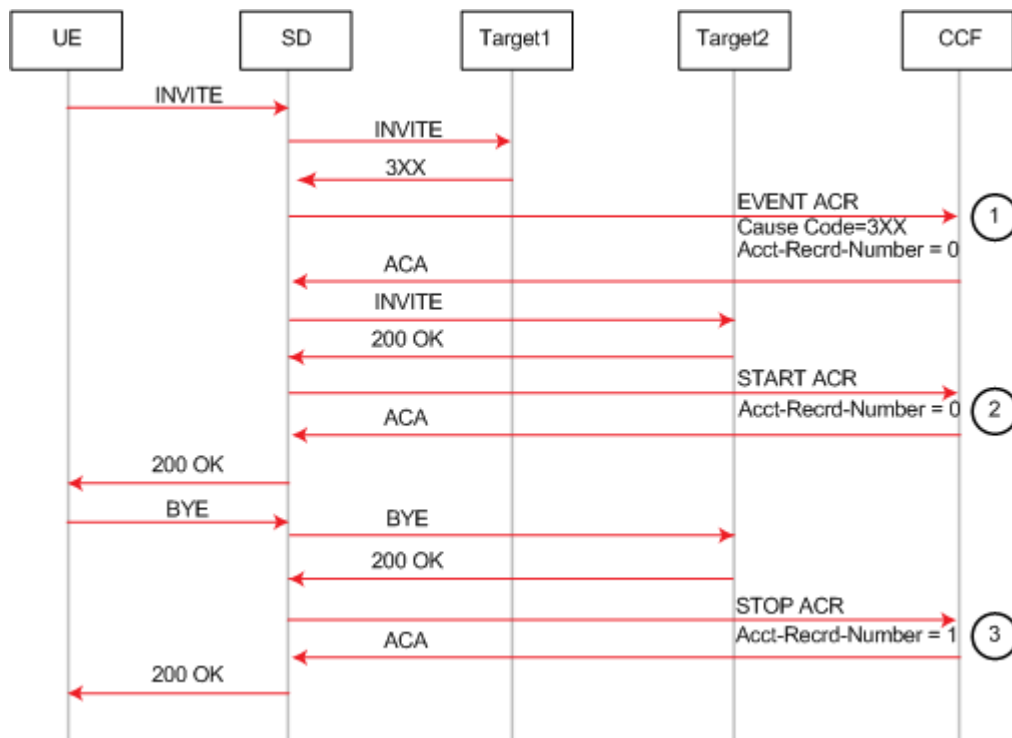

Event ACR Created Upon Reception of a 3xx Message Followed by Call Success After Redirect

This example call flow shows a Start ACR being sent when an Invite is received and an Interim ACR that is created due to the reception of a 3xx SIP message. In this example the call succeeds after being redirected. The generate-start is Invite.

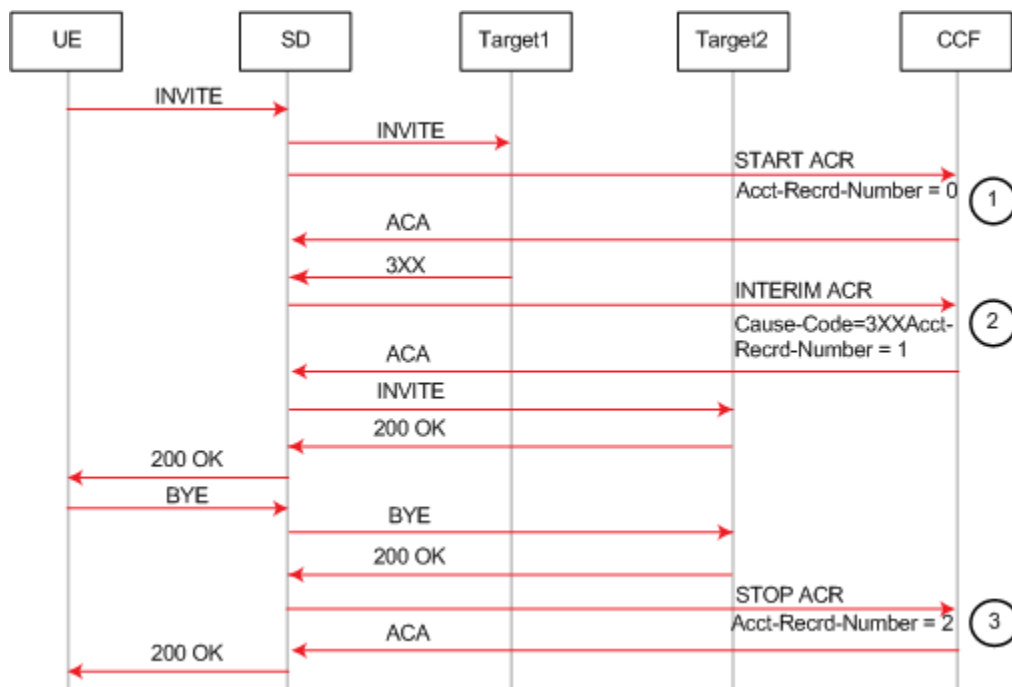

Event Local CSV File

This feature also creates an Event CSV file when the **generate-event** parameter is enabled. The following table describes the inclusive CSV element order:

CSV Placement	Attribute Name	AVP Number
1	Record Type	480
2	NAS IP Address	
3	NAS Port	16
4	Calling Station ID	
5	Called Station ID	
6	Diameter Session ID	263
7	SIP Method	824
8	Event Time	55
9	User Name	1
10	Node Function	862
11	Application ID	259
12	Role Node	829
13	Event	825
14	Expires	888
15	Associated URI	856
16	Cause Code	861
17	CDR Sequence Number	
18	Origin Realm	296
19	Origin Host	264
20	Destination Realm	283
21	Destination Host	

Diameter Heartbeat for Rf

Device-Watchdog-Request (DWR) and Device-Watchdog-Answer (DWA) messages are used to detect transport failures at the application layer between the OCSBC communicating with a policy server via Diameter. The request/answer message pair forms a heartbeat mechanism that can alert the requesting side if the answering side is not reachable.

The OCSBC always responds to a DWR by replying with a DWA message. In addition, the OCSBC can be configured to initiate DWR messages toward a policy server or other Diameter-based network device.

You configure the **watchdog ka timer** to indicate the period between the DWRs the OCSBC sends to a Diameter Agent, an Rf based server in this case.

If the OCSBC fails to receive a DWA response from the Server within 1/4 of the configured **watchdog ka timer** parameter, then the connection towards that Server is considered failed and torn down. The OCSBC attempts to recreate the TCP connection, followed by the recreating the Diameter connection by issuing a CEA toward the policy server.

When other Rf traffic to/from the accounting server is present, DWRs are suspended. The other traffic indicates that the server is up. The OCSBC upon detection of DWR failure can send accounting data towards another configured accounting server by failover/strategy mechanisms.

Configuring Diameter-based Accounting

Diameter-based Rf accounting relies on many of the same configuration elements used for RADIUS based accounting. The following two sections explain how to configure both the **account-config** and **account-servers** configuration elements. In addition, you must ensure that accounting is enabled for each realm where you want it to occur. The **accounting-enable** parameter in the realm-config is enabled by default.

Configure the Global Diameter-based Accounting (Rf) Features

To configure the global Diameter-based accounting (Rf) features in the account-config:

1. In Superuser mode, type **configure terminal** and press Enter.

```
ORACLE# configure terminal
```

2. Type **session-router** and press Enter.

```
ORACLE(configure)# session-router
```

3. Type **account-config** and press Enter.

```
ORACLE(session-router)# account-config  
ORACLE(account-config)#
```

4. **hostname**—Enter a hostname for this system.
5. **port**—Enter 3868 for the RFC-recommended Diameter port number. You may enter a different port number.
 - minimum: 1025
 - maximum: 65535
6. **strategy**—Set the strategy used to select the accounting server which the OCSBC sends accounting messages. The following are the available strategies:
 - **hunt**—Selects accounting servers in the order in which they are listed. If the first accounting server is online, working, and has not exceeded any of the defined constraints, all traffic is sent to it. Otherwise the second accounting server is selected. If the first and second accounting servers are offline or exceed any defined constraints, the third accounting server is selected. And so on through the entire list of configured servers
 - **failover**—Uses the first server in the list of predefined accounting servers until a failure is received from that server. Once a failure is received, it moves to the second accounting server in the list until a failure is received. And so on through the entire list of configured servers.
 - **round robin**—Selects each accounting server in order, distributing the selection of each accounting server evenly over time.

- fastest round trip time—Selects the accounting server that has the fastest round trip time (RTT) observed during transactions with the servers (sending a record and receiving an ACK).
 - fewest pending—Selects the accounting server that has the fewest number of unacknowledged accounting messages (that are in transit to the OCSBC).
7. **protocol**—Set this parameter to **diameter** to use the Rf accounting interface with a Diameter-based accounting server.
 8. **state**— Enter **enabled** to use accounting on this system.
 9. **max-msg-delay**—Retain the default value of **60** seconds or indicate the length of time in seconds that you want the OCSBC to continue trying to send each accounting message. During this delay, the OCSBC can hold a generic queue of 4096 messages.
 - Minimum: zero (0)
 - Maximum: 4294967295
 10. **acr-retry-interval** — Retain the default value of **10** seconds or enter the time in seconds for the OCSBC to wait before resending an ACR for a session.
 - Minimum: 5
 - Maximum: 20
 11. **max-acr-retries** — Retain the default value of zero (**0**) or enter the maximum number of times that the OCSBC can resend an ACR for a session.
 - Minimum: zero (0)
 - Maximum: 4
 12. **max-wait-failover**—Retain the default value of **100** messages or indicate the maximum number of accounting messages the OCSBC can store its message waiting queue for a specific accounting server, before it is considered a failover situation.

Once this value is exceeded, the OCSBC attempts to send its accounting messages, including its pending messages, to the next accounting server in its configured list.

 - Minimum: one (1) message
 - Maximum: 4096 messages
 13. **trans-at-close**—Retain the default value of **disabled** if you do not want to defer the transmission of message information to the close of a session. Enter **enabled** if you want to defer message transmission.
 - **disabled**—The OCSBC transmits accounting information at the start of a session (Start), during the session (Interim), and at the close of a session (Stop). The transmitted accounting information for a single session might span a period of hours and be spread out among different storage files.
 - **enabled**—Limits the number of files on the OCSBC used to store the accounting message information for one session. It is easiest to store the accounting information from a single session in a single storage file.
 14. **generate-start**—Retain the default value **ok** if you want the ACR Start message to be generated once the OCSBC receives an OK message in response to an INVITE.

Other options include:

- none—Accounting Start message should not be generated.
 - invite—Accounting Start message should be generated once the OCSBC receives a SIP INVITE.
 - ""—When two quotation marks are entered next to each other (empty), behavior is identical to none value.
- 15. generate-interim**—Retain the default value **reinvite-response** to cause the OCSBC to send an Interim charging message to the accounting server.
- You can select none, one, or more than one of the following values:
- ok—Start message is generated when the OCSBC receives an OK message in response to an INVITE.
 - reinvite—Interim message is generated when the OCSBC receives a SIP session reINVITE message.
 - reinvite-response (default)—Interim message is generated when the OCSBC receives a SIP session reINVITE and responds to it (for example, session connection or failure).
 - reinvite-cancel—Interim message is generated when the OCSBC receives a SIP session reINVITE, and the Reinvite is cancelled before the OCSBC responds to it.
 - unsuccessful-attempt—Interim message is generated when a SIP session set-up attempt from a preference-ordered list of next-hop destinations is unsuccessful. This can happen when a local policy lookup, LRT lookup, ENUM query response, or SIP redirect returns a preference-ordered list of next-hop destinations. The interim message contains: the destination IP address, the disconnect reason, a timestamp for the failure, and the number that was called.
- 16. generate-event**—Enter one or more valid events that prompt creation of an Event record. Enclosed multiple values in parenthesis and separate by spaces.
- value settings include triggering the OCSBC to generate an accounting message when it:
- none—(default)
 - Register—Receives a SIP REGISTER.
 - Local-Register—Prompts the OCSBC to create Event ACRs on a re-REGISTER to which it replied.
 - message—Receives an SMS message.
- 17. intermediate-period**—Enter amount of time in seconds between generating periodic interim ACR messages during a SIP call. This parameter defaults to zero, which disables continuous Interim charging messages.
- 18. vsa-id-range**—Ensure that this parameter is left blank when communicating with a Diameter-based Rf accounting server.
- 19.** Save your work.

Configure Accounting Servers

You must create one or more servers to which the OCSBC can send accounting messages.

1. Continuing from the previous account-config configuration, enter the account server sub-element by typing **account-servers** Enter.

```
AZALEA(account-config)# account-servers  
AZALEA(account-server)#
```

2. **hostname**—Set this to the IP address of the Diameter-based Rf accounting server.
3. **port**—Enter 3868 for the RFC-recommended Diameter port number. You may enter a different port number if desired.
 - minimum: 1025
 - maximum: 65535
4. **state**—Retain the default enabled to enable this account server or enter disabled to disable it.
5. **min-round-trip**—Retain the default 250 milliseconds or indicate the minimum round trip time of an accounting message.
 - minimum: 10 milliseconds
 - maximum: 5000 milliseconds

A round trip consists of the following:

The OCSBC sends an accounting message to the account server.

The account server processes this message and responds back to the OCSBC.

If the fastest RTT is the strategy for the account configuration, the value you enter here can be used to determine an order of preference (if all the configured account servers are responding in less than their minimum RTT).

6. **max-inactivity**—Retain the default 60 seconds or indicate the length of time in seconds that you want the OCSBC with pending accounting messages to wait when it has not received a valid response from the target account server.
 - minimum: 1 second
 - maximum: 300 seconds

Once this timer value is exceeded, the OCSBC marks the unresponsive account server as disabled in its failover scheme. When a server connection is marked as inactive, the OCSBC attempts to restart the connection and transfers pending messages to another queue for transmission. Accounting messages might be moved between different account servers as servers become inactive or disabled.

7. **restart-delay**—Retain the default 30 seconds or indicate the length of time in seconds you want the OCSBC to wait before resending messages to a disabled account server.
 - minimum: 1 second
 - maximum: 300 seconds
8. **priority**—Enter the number corresponding to the priority of this account server, for use with server prioritization. The default for this parameter is 0, meaning the prioritization feature is turned off—and that the OCSBC will therefore prioritize accounting servers by IP address and port.

9. **origin-realm**—Enter the realm in which the OCSBC communicates with the Diameter Rf accounting server.
10. **domain-name-suffix**—Enter the suffix to be appended to any Diameter FQDN or Diameter Identity used when the OCSBC communicates with the Diameter Rf accounting server. Your value can be any string, to which the OCSBC will prepend with a dot.
11. **watchdog-ka-timer**—Set this parameter to the value in seconds that the OCSBC waits between sending DWRs. 0 disables this feature. Valid non-zero values are 6 - 65535
12. Save your work.

Additional Rf Features Alarms and Traps

Service-Context-ID Format

The Service-Context-ID AVP (461) located in the root ACR message is formatted as follows:

```
[ [ [ "extensions" . ] MNC.MCC . ] "Release" . ] 32260@3gpp.org
```

where

- **extensions**—This is operator specific information to any extensions in a service specific document. The value is configured by setting the **diam-srv-ctx-ext** parameter.
- **MNC.MCC**—This identifies the operator implementing the service specific document, which is used to determine the specific requirements for the operator configurable parameters. Both MNC and MCC must be specified separated by a dot(.). The value is configured by setting the **diam-srv-ctx-mnc-mcc** parameter as two integers separated by a dot. For example: 012.310
- **Release**—This indicates the 3GPP Release the service specific document is based upon e.g. 6 for Release 6. The value is configured by setting the **diam-srv-ctx-rel** parameter with valid values are >=1.

Note:

"32260@3gpp.org" is fixed.

Acme Excluded Attribute Range

You can select certain ACME specific AVPs to include in the Rf accounting records with the **diam-acme-attr-id-range** parameter. If this parameter is configured with one or more values, then all other valid Acme-specific AVPs, by number, are excluded. If by configuration, the OCSBC will exclude one (or more) individual ACME attributes, there will be no effect. If by configuration an Acme-specific attribute number that refers to a group is excluded, the OCSBC removes the complete grouped AVP from the ACR message.

Consider:

- Acme-specific attribute 1—The grouped AVP
- Acme-specific attributes 2-35—The individual AVPs that make up the group

If you configure **diam-acme-attr-id-range 1,3-** the OCSBC includes all attributes in the Acme group; This configuration aims to exclude only attribute 3 but is has no effect.

If you configure **diam-acme-attr-id-range 2-**, the OCSBC excludes the full Acme-specific group because Acme-Packet-Specific-Extension-Rf AVP (1) was not included.

The **diam-acme-attr-id-range** parameter's syntax is as follows:

Syntax	Meaning
X-Y	include range of attribute IDs from X to Y (X and Y are included)
-Y	include any attribute ID <= Y
X-	include any attribute ID >= X
-	include any attribute ID
X	include attribute ID = X

Configure Account

1. In Superuser mode, type **configure terminal** and press Enter.

```
ORACLE# configure terminal
```

2. Type **session-router** and press Enter.

```
ORACLE(configure)# session-router
```

3. Type **account-config** and press Enter.

```
ORACLE(session-router)# account-config
ORACLE(account-config)#
```

4. **diam-srv-ctx-ext**—Enter the extension portion of the Service-Context-ID AVP value. This value can be any string.
5. **diam-srv-ctx-mnc-mcc**—Enter the MNC.MCC portion of the Service-Context-ID AVP value. This value must follow the NUM1.NUM2 format.
6. **diam-srv-ctx-rel**—Enter the release portion of the Service-Context-ID AVP value. This value can be any number >= 1..
7. **diam-acme-attr-id-range**—Enter the range of Acme-specific AVPs to include in ACR messages. Leaving this parameter blank or configured with a - includes all AVPs.
8. Type **done** to save your work.

SNMP Trap Behavior

The OCSBC sends an SNMP trap (apDiameterSvrErrorResult) upon a CCF returning an error-containing ACA. See the list of four errors (3002, 3004, 4002, 5012) which generate traps in the [Alarms](#) section. The frequency at which subsequent traps are

sent is based upon configuring the **diam result code trap grade period** option configured in the account config.

When the OCSBC has sent a trap after receiving a bad ACA, it goes into an error state. The OCSBC waits one grace period before checking if it is still in an error state. If the state has not switched from errored back to pending, the OCSBC sends another error trap, after that first grace period ends (counting from the initial error) and then after the next error message is received.

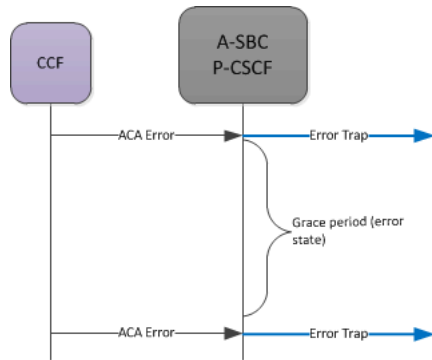

If the CCF returns a successful message, the grace start in a pending state. When this second timer expires (pending no more errors or additional successes), on the next successful ACA, a success trap is sent.

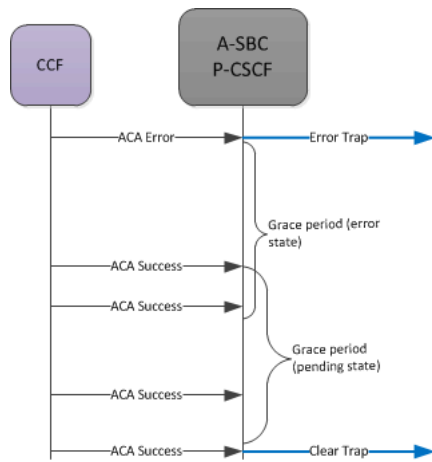

If, while in the pending grace period an ACA error is received, the OCSBC immediately sends an error trap, and begins the error state again. It also starts counting the initial grace period time again.

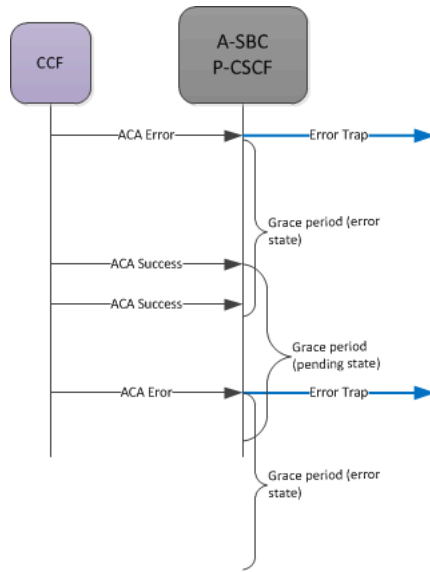

Alarms

A MINOR non health affecting Diameter Accounting Server Error alarm will be generated when one of the following Result Codes is received:

- 3002 (DIAMETER_UNABLE_TO_DELIVER)
- 3004 (DIAMETER_TOO_BUSY)
- 4002 (DIAMETER_OUT_OF_SPACE)
- 5012 (DIAMETER_UNABLE_TO_COMPLY)

The alarm is cleared when a success (2XXX) code is received.

The rules for setting state of the failed server alarm are the same as the grace period rules described in the [SNMP Trap Behavior](#) section.

For example:

```

327703 835778540      5      2012-03-13 13:03:34      2012-03-13
13:03:34
Count  Description
1      Diameter Accounting Server Returned Error Result Code|
172.30.0.135:3869-5012|172.30.69.211:3868-3002
    
```

SNMP MIBs and Traps

ApDiamResultCode Textual Convention

```

ApDiamResultCode ::= TEXTUAL-CONVENTION
    STATUS          current
    DESCRIPTION
        "The Result-Code AVP (268) value
        RFC 3588, 7.1. Result-Code AVP"
    
```

```

SYNTAX INTEGER {
    diameterMultiRoundAuth(1001),
    diameterSuccess(2001),
    diameterLimitedSuccess(2002),
    diameterCommandUnsupported(3001),
    diameterUnableToDeliver(3002),
    diameterRealmNotServed(3003),
    diameterTooBusy(3004),
    diameterLoopDetected(3005),
    diameterRedirectIndicatoion(3006),
    diameterApplicationUnsupported(3007),
    diameterInvalidHdrBits(3008),
    diameterInvalidAvpBits(3009),
    diameterUnknownPeer(3010),
    diameterAuthenticationRejected(4001),
    diameterOutOfSpace(4002),
    electionLost(4003),
    diameterAvpUnsupported(5001),
    diameterUnknownSessionId(5002),
    diameterAuthoriszationRejected(5003),
    diameterInvalidAvpValue(5004),
    diameterMissingAvp(5005),
    diameterResourcesExceeded(5006),
    diameterContradictingAvps(5007),
    diameterAvpNotAllowed(5008),
    diameterAvpTooManyTimes(5009),
    diameterNoCommonApplication(5010),
    diameterUnsupportedVersion(5011),
    diameterUnableToComply(5012),
    diameterInvalidBitInHeader(5013),
    diameterInvalidAvpLength(5014),
    diameterInvalidMessageLength(5015),
    diameterInvalidAvpBitCombo(5016),
    diameterNoCommonSecurity(5017)
}

```

apDiameterSvrErrorResultTrap

```

apDiameterSvrErrorResultTrap      NOTIFICATION-TYPE
    OBJECTS                        { apDiamAcctSvrHostName,
                                    apDiamAcctSvrIPPort,
                                    apDiamAcctSvrOriginRealm,
                                    apDiamAcctSvrOriginHost,
                                    apDiamAcctSvrTransportType,
                                    apDiameterResultCode
                                    }
    STATUS                          current
    DESCRIPTION
        " The trap can be generated when the Diameter Server
          returns 3xxx (Protocol Errors), 4xxx (Transient
          Failures), or
          5xxx (Permanent Failure) Result-Code AVP (268)"
    ::= { apDiamNotifications 5 }

```

apDiameterSrvrSuccessResultTrap

```

apDiameterSrvrSuccessResultTrap      NOTIFICATION-TYPE
    OBJECTS      { apDiamAcctSrvrHostName,
                   apDiamAcctSrvrIPPort,
                   apDiamAcctSrvrOriginRealm,
                   apDiamAcctSrvrOriginHost,
                   apDiamAcctSrvrTransportType,
                   apDiameterResultCode
                   }
    STATUS      current
    DESCRIPTION
        " The trap can be generated when the Diameter Server
          returns a 2xxx (Success) Result-Code AVP (268)
          after an error result"
    ::= { apDiamNotifications 6 }

```

apDiamACCTResultObjectsGroup Object Group

```

apDiamACCTResultObjectsGroup OBJECT-GROUP
    OBJECTS {
        apDiameterResultCode
    }
    STATUS      current
    DESCRIPTION
        "A collection of mib objects accessible only to traps."
    ::= { apDiamNotificationGroups 3 }

```

apDiamACCTResultNotificationsGroup Notification Group

```

apDiamACCTResultNotificationsGroup NOTIFICATION-GROUP
    NOTIFICATIONS {
        apDiameterSrvrErrorResultTrap,
        apDiameterSrvrSuccessResultTrap
    }
    STATUS      current
    DESCRIPTION
        "A collection of traps defined for ACCT Result Code."
    ::= { apDiamNotificationGroups 4 }

```

SNMP Varbind Definitions

- apDiamAcctSrvrHostName—contains the account-server hostname.
- apDiamAcctSrvrIPPort—This object contains the account-server IP address and port number in the following format:
XXX.XXX.XXX.XXX:PORT
- apDiamAcctSrvrOriginRealm—contains the origin realm, which is a concatenation of the account-server realm and suffix in the following format:
[account-server realm][account-server suffix]

- `apDiamAcctSrvrOriginHostName`—contains the origin host name, which is a concatenation of the accounting-config host name, account-server realm and account-server suffix in the following format:
[accounting-config host name].[account-server realm][account-server suffix]
- `apDiamAcctSrvrTransportType`—contains the transport type.
- `apDiameterResultCode`—contains the Result-Code AVP (268) value as defined in RFC 3588, 7.1. Result-Code AVP

Diameter Rf Charging Buffering and Storage

About Buffering

Diameter Rf Charging, Buffering, and Storage enables the OCSBC to buffer all accounting requests (ACR) in memory for a configurable number of ACRs. The buffer holds a minimum of 15 minutes of ACRs under busy-hour load conditions. For example, based on intended traffic, the buffer would hold 54 calls-per-second which equals approximately 150,000 records. The OCSBC sends an SNMP trap when accounting records begin to drop from the buffer due to an overflow condition. Subsequently, a clearing SNMP trap is sent once the fault condition is removed.

About Storage

The OCSBC maintains storage to temporarily store accounting records to a charging collection function (CCF) link, in case of a failure or congestion exists on the OCSBC. In this scenario, the OCSBC can store a minimum of 3 days-worth of accounting records. All ACRs can remain in storage for a configurable amount of time, and for a minimum of 3 days under normal traffic-load conditions.

There are two configurable options for storing ACRs:

- Store all ACRs generated by the OCSBC
- No ACRs in storage

Monitoring Storage Space

Disk storage space monitoring can be done on the total drive, or by disk partition. You can monitor storage space using the one of the following methods:

- Command line interface (CLI)
- SNMP management information base (MIB)
- Historical data records (HDR)

ACLI Instructions and Examples

To configure Diameter Rf buffering and storage size:

1. In Superuser mode, type `configure terminal` and press Enter.

```
ORACLE# configure terminal
```

2. Type **session-router** and press Enter.

```
ORACLE(configure)# session-router
ORACLE(session-router)#
```

3. Type **account-config** and press Enter.

```
ORACLE(session-router)# account-config
ORACLE(account-config)#
```

- If you are adding support for this feature to a pre-existing configuration, then you must select (using the ACLI **select** command) the configuration that you want to edit.
4. **diam-attr-id-range**—Comma delimited range of accounting attributes to include in DIAMETER Rf accounting records (blank field means feature turned off and all attributes included).
 5. **msg-queue-size**—Enter the message queue size. **This parameter applies to both RADIUS and Diameter accounting interfaces.** The valid range is 5000 - 150000. The default value is 5000.
 6. Save your work.

SNMP

SNMP traps will be sent to the configured management system(s) when accounting records begin to drop due to an overflow condition and when this fault condition is removed:

- apAcctMsgQueueFullTrap will be sent when accounting records begin to drop due to an overflow condition and all accounting servers are down
- apAcctMsgQueueFullClearTrap will be sent when the apAcctMsgQueueFullTrap fault condition is cleared

The following varbinds are defined for the above traps

- apAcctMsgQueueCurrent

The current measured percentage value of space available

- apAcctMsgQueueMinorThreshold

The current configured minor threshold value

- apAcctMsgQueueMajorThreshold

The current configured major threshold value

- apAcctMsgQueueCriticalThreshold

The current configured critical threshold value.

DIAMETER Rf Charging Failure & Recovery Detection

The OCSBC can detect and report when the DIAMETER Rf interface has failed and when it has recovered.

- Transport failure detection—The OCSBC sends SNMP traps to the configured management systems when a Diameter Rf Charging transport failure has been detected. If multiple transport failures have been detected, an SNMP trap is sent for each failure.
- Transport recovery detection—When a Diameter Rf Charging CCF has recovered and is back in service, an SNMP trap notification is sent by the OCSBC to the configured management systems notifying of that event.

Associated Traps

SNMP traps will be sent to the configured management system(s) when a transport failure or recovery is detected:

- `apDiameterAcctSvrDownTrap` will be sent if OCSBC can't connect to a configured Diameter Accounting Server after reboot
- `apDiameterAcctSvrDownTrap` will be sent if OCSBC loses connection to a configured Diameter Accounting Server during normal operations
- `apDiameterAcctSvrUpTrap` will be sent if OCSBC regains connection to a configured Diameter Accounting Server after a previous connection loss

The following varbinds are defined for the above traps:

- `apDiamAcctSvrHostName`—This object will contain account-server hostname.
- `apDiamAcctSvrIPPort`—This object will contain account-server IP address (which is the same as the hostname since we don't support FQDN for the account-server hostname) and port number in the following format: `XXX.XXX.XXX.XXX:PORT`.
- `apDiamAcctSvrOriginRealm`—This object will contain the origin realm, which is a concatenation of the account-server realm and suffix in the following format:

[account-server realm][account-server suffix]

- `apDiamAcctSvrOriginHostName`—This object will contain the origin host name, which is a concatenation of the accounting-config host name, account-server realm and account-server suffix in the following format:

[accounting-config host name].[account-server realm][account-server suffix]

- `apDiamAcctSvrTransportType`—This object will contain the transport type. At this time only the TCP transport type is supported

A

RADIUS Dictionary Reference

For RADIUS dictionary content, refer to the radius file in this version's documentation library.

B

Comma-Delimited Entries for Local Files

Local File Format

This section contains an example table that shows where, in locally-generated CSV files, specific VSAs may appear. The table is for an Interim CDR to a successful call. The user can produce the formats of local CDRs based on their configuration using the **dump_csv_format** command, documented in the Configuring Accounting chapter.

For more information about this feature and how to enable it, refer to the Local CDR Storage and FTP Push section in this guide's Configuring Accounting chapter. Note that the Acme-CDR-Sequence-Number, VSA ID 59, appears in local CDR files when both file-output is enabled and an account server is configured.

Interim Record CSV Placement

CSV Placement	Attribute Name	VSA ID Number
1	Acct-Status-Type	N/A
2	NAS-IP-Address	N/A
3	NAS-Port	N/A
4	Acct-Session-Id	N/A
5	Acme-Session-Ingress-CallId	3
6	Acme-Session-Egress-CallId	4
7	Acme-Session-Protocol-Type	43
8	Acme-Session-Forked-Call-Id	171
9	Acme-Session-Generic-Id	40
10	Calling-Station-Id	N/A
11	Called-Station-Id	N/A
12	h323-setup-time	N/A
13	h323-connect-time	N/A
14	Acme-Egress-Network-Interface-Id	139
15	Acme-Egress-Vlan-Tag-Value	140
16	Acme-Ingress-Network-Interface-Id	137
17	Acme-Ingress-Vlan-Tag-Value	138
18	Acme-Session-Egress-Realm	42
19	Acme-Session-Ingress-Realm	41
20	Acme-FlowId_FS1_F	1
21	Acme-FlowType_FS1_f	2
22	Acme-Flow-In-Realm_FS1_f	10
23	Acme-Flow-In-Src-Addr_FS1_F	11
24	Acme-Flow-In-Src-Port_FS1_F	12

CSV Placement	Attribute Name	VSA ID Number
25	Acme-Flow-In-Dst-Addr_FS1_F	13
26	Acme-Flow-In-Dst-Port_FS1_F	14
27	Acme-Flow-Out-Realm_FS1_F	20
28	Acme-Flow-Out-Src-Addr_FS1_F	21
29	Acme-Flow-Out-Src-Port_FS1_F	22
30	Acme-Flow-Out-Dst-Addr_FS1_F	23
31	Acme-Flow-Out-Dst-Port_FS1_F	24
32	Acme-Calling-RTCP-Packets-Lost_FS1	32
33	Acme-Calling-RTCP-Avg-Jitter_FS1	33
34	Acme-Calling-RTCP-Avg-Latency_FS1	34
35	Acme-Calling-RTCP-MaxJitter_FS1	35
36	Acme-Calling-RTCP-MaxLatency_FS1	36
37	Acme-Calling-RTP-Packets-Lost_FS1	37
38	Acme-Calling-RTP-Avg-Jitter_FS1	38
39	Acme-Calling-RTP-MaxJitter_FS1	39
40	Acme-Calling-Octets_FS1	28
41	Acme-Calling-Packets_FS1	29
42	Acme-Calling-R-Factor	151
43	Acme-Calling-MOS	152
44	Acme-FlowID_FS1_R	78
45	Acme-FlowType_FS1_R	79
46	Acme-Flow-In-Realm_FS1_R	80
47	Acme-Flow-In-Src-Addr_FS1_R	81
48	Acme-Flow-In-Src-Port_FS1_R	82
49	Acme-Flow-In-Dst-Addr_FS1_R	83
50	Acme-Flow-In-Dst-Port_FS1_R	84
51	Acme-Flow-Out-Realm_FS1_R	85
52	Acme-Flow-Out-Src-Addr_FS1_R	86

CSV Placement	Attribute Name	VSA ID Number
53	Acme-Flow-Out-Src-Port_FS1_R	87
54	Acme-Flow-Out-Dst-Addr_FS1_R	88
55	Acme-Flow-Out-Dst-Port_FS1_R	89
56	Acme-Called-RTCP-Packets-Lost_FS1	46
57	Acme-Called-RTCP-Avg-Jitter_FS1	47
58	Acme-Called-RTCP-Avg-Latency_FS1	48
59	Acme-Called-RTCP-MaxJitter_FS1	49
60	Acme-Called-RTCP-MaxLatency_FS1	50
61	Acme-Called-RTP-Packets-Lost_FS1	51
62	Acme-Called-RTP-Avg-Jitter_FS1	52
63	Acme-Called-RTP-MaxJitter_FS1	53
64	Acme-Called-Octets_FS1	44
65	Acme-Called-Packets_FS1	45
66	Acme-Called-R-Factor	153
67	Acme-Called-MOS	154
68	Acme-FlowID_FS2_F	90
69	Acme-FlowType_FS2_F	91
70	Acme-Flow-In-Realm_FS2_F	92
71	Acme-Flow-In-Src-Addr_FS2_F	93
72	Acme-Flow-In-Src-Port_FS2_F	94
73	Acme-Flow-In-Dst-Addr_FS2_F	95
74	Acme-Flow-In-Dst-Port_FS2_F	96
75	Acme-Flow-Out-Realm_FS2_F	97
76	Acme-Flow-Out-Src-Addr_FS2_F	98
77	Acme-Flow-Out-Src-Port_FS2_F	99
78	Acme-Flow-Out-Dst-Addr_FS2_F	100
79	Acme-Flow-Out-Dst-Port_FS2_F	101
80	Acme-Calling-RTCP-Packets-Lost_FS2	104

CSV Placement	Attribute Name	VSA ID Number
81	Acme-Calling-RTCP-Avg-Jitter_FS2	105
82	Acme-Calling-RTCP-Avg-Latency_FS2	107
83	Acme-Calling-RTCP-MaxJitter_FS2	107
84	Acme-Calling-RTCP-MaxLatency_FS2	108
85	Acme-Calling-RTP-Packets-Lost_FS2	109
86	Acme-Calling-RTP-Avg-Jitter_FS2	110
87	Acme-Calling-RTP-MaxJitter_FS2	111
88	Acme-Calling-Octets_FS2	102
89	Acme-Calling-Packets_FS2	103
90	Acme-FlowID_FS2_R	112
91	Acme-FlowType_FS2_R	113
92	Acme-Flow-In-Realm_FS2_R	114
93	Acme-Flow-In-Src-Addr_FS2_R	115
94	Acme-Flow-In-Src-Port_FS2_R	116
95	Acme-Flow-In-Dst-Addr_FS2_R	117
96	Acme-Flow-In-Dst-Port_FS2_R	118
97	Acme-Flow-Out-Realm_FS2_R	119
98	Acme-Flow-Out-Src-Addr_FS2_R	120
99	Acme-Flow-Out-Src-Port_FS2_R	121
100	Acme-Flow-Out-Dst-Addr_FS2_R	122
101	Acme-Flow-Out-Dst-Port_FS2_R	123
102	Acme-Called-RTCP-Packets-Lost_FS2	126
103	Acme-Called--RTCP-Avg-Jitter_FS2	127
104	Acme-Called--RTCP-Avg-Latency_FS2	128
105	Acme-Called--RTCP-MaxJitter_FS2	129
106	Acme-Called-RTCP-MaxLatency_FS2	130
107	Acme-Called-RTP-Packets-Lost_FS2	131

CSV Placement	Attribute Name	VSA ID Number
108	Acme-Called-RTP-Avg-Jitter_FS2	132
109	Acme-Called-RTP-MaxJitter_FS2	133
110	Acme-Called-Octets_FS2	124
111	Acme-Called-Packets_FS2	125
112	Acme-Session-Charging-Vector	54
113	Acme-Session-Charging-Function_Address	55
114	Acme-Firmware-Version	56
115	Acme-Local-Time-Zone	57
116	Acme-Post-Dial-Delay	58
117	Acme-Primary-Routing-Number	64
118	Acme-Originating-Trunk-Group	65
119	Acme-Terminating-Trunk-Group	66
120	Acme-Originating-Trunk-Context	67
121	Acme-Terminating-Trunk-Context	68
122	Acme-P-Asserted-ID	69
123	Acme-Ingress-Local-Addr	74
124	Acme-Ingress-Remote-Addr	75
125	Acme-Egress-Local-Addr	76
126	Acme-Egress-Remote-Addr	77
127	Acme-SIP-Diversion	70
128	Acme-Intermediate_Time	63
129	Acct-Session-Time	N/A
130	Acme-Egress-Final-Routing-Number	134
131	Acme-Session-Ingress-RPH	135
132	Acme-Session-Egress-RPH	136
133	Acme-Custom-VSA-200	200
134	Acme-Custom-VSA-201	201
135	Acme-Custom-VSA-202	202
136	Acme-Custom-VSA-203	203
137	Acme-Custom-VSA-204	204
138	Acme-Custom-VSA-205	205
139	Acme-Custom-VSA-206	206
140	Acme-Custom-VSA-207	207
141	Acme-Custom-VSA-208	208
142	Acme-Custom-VSA-209	209
143	Acme-Custom-VSA-210	210
144	Acme-Custom-VSA-211	211
145	Acme-Custom-VSA-212	212

CSV Placement	Attribute Name	VSA ID Number
146	Acme-Custom-VSA-213	213
147	Acme-Custom-VSA-214	214
148	Acme-Custom-VSA-215	215
149	Acme-Custom-VSA-216	216
150	Acme-Custom-VSA-217	217
151	Acme-Custom-VSA-218	218
152	Acme-Custom-VSA-219	219
153	Acme-Custom-VSA-220	220
154	Acme-Custom-VSA-221	221
155	Acme-Custom-VSA-222	222
156	Acme-Custom-VSA-223	223
157	Acme-Custom-VSA-224	224
158	Acme-Custom-VSA-225	225
159	Acme-Custom-VSA-226	226
160	Acme-Custom-VSA-227	227
161	Acme-Custom-VSA-228	228
162	Acme-Custom-VSA-229	229
163	Acme-Custom-VSA-230	230
164	Acme-Flow-Calling-Media- Stop-Time_FS1	231
165	Acme-Flow-Called-Media- Stop-Time_FS1	232
166	Acme-Flow-Calling-Media- Stop-Time_FS2	233
167	Acme-Flow-Called-Media- Stop-Time_FS2	234
168	Acme-FlowMediaType_FS1_F	142
169	Acme-FlowMediaType_FS1_R	143
170	Acme-FlowMediaType_FS2_F	144
171	Acme-FlowMediaType_FS2_R	145
172	ACME-Access-Network- Information	248
173	Acme-CDR-Sequence- Number	59

C

Comma-Delimited Local Files for Diameter Rf Accounting

Local File Format

This section contains an example table that shows where, in locally-generated CSV files, specific VSAs may appear. The example table is for an Interim CDR to a successful call. The user can produce the formats of local CDRs based on their configuration using the **dump_csv_format** command, documented in the Configuring Accounting chapter.

For more information about this feature and how to enable it, refer to the Local CDR Storage and FTP Push section in this guide's Configuring Accounting chapter. Note that the Acme-CDR-Sequence-Number, Vendor ID 59, appears in local CDR files when both file-output is enabled and an account server is configured.

Interim Record on Successful Call CSV Order

The following ordered list of attributes appears when the account-config has the following parameters set:

```
cdr-output-inclusive enabled
```

CSV Placement	Attribute Name	RADIUS ID	Vendor ID
1	Acct-Status-Type	N/A	N/A
2	NAS-IP-Address	N/A	N/A
3	NAS-Port	N/A	N/A
4	Acct-Session-Id	N/A	N/A
5	Acme-Session-Ingress-CallId	3	N/A
6	Acme-Session--Egress-CallId	4	N/A
7	Acme-Session-Protocol-Type	43	N/A
8	Acme-Session-Forked-Call-Id	N/A	N/A
9	Acme-Session--Generic-Id	N/A	N/A
10	Calling-Station-Id	N/A	N/A
11	Called-Station-Id	N/A	N/A
12	h323-setup-time	26	N/A
13	h323-connect-time	26	N/A
14	Acme-Egress-Network-Interface-Id	26	139
15	Acme-Egress-Vlan-Tag-Value	26	140

CSV Placement	Attribute Name	RADIUS ID	Vendor ID
16	Acme-Ingress- Network-Interface-Id	26	137
17	Acme-Ingress-Vlan- Tag-Value	26	138
18	Acme-Session- Egress-Realm	26	42
19	Acme-Session- Ingress-Realm	26	41
20	Acme-FlowId_FS1_F	26	1
21	Acme- FlowType_FS1_F	26	2
22	Acme-Flow-In- Realm_FS1_F	26	10
23	Acme-Flow-In-Src- Addr_FS1_F	26	11
24	Acme-Flow-In-Src- Port_FS1_F	26	12
25	Acme-Flow-In-Dst- Addr_FS1_F	26	13
26	Acme-Flow-In-Dst- Port_FS1_F	26	14
27	Acme-Flow-Out- Realm_FS1_F	26	20
28	Acme-Flow-Out-Src- Addr_FS1_F	26	21
29	Acme-Flow-Out-Src- Port_FS1_F	26	22
30	Acme-Flow-Out-Dst- Addr_FS1_F	26	23
31	Acme-Flow-Out-Dst- Port_FS1_F	26	24
32	Acme-Calling-RTCP- Packets-Lost_FS1	26	32
33	Acme-Calling-RTCP- Avg-Jitter_FS1	26	33
34	Acme-Calling-RTCP- Avg-Latency_FS1	26	34
35	Acme-Calling-RTCP- MaxJitter_FS1	26	35
36	Acme-Calling-RTCP- MaxLatency_FS1	26	36
37	Acme-Calling-RTP- Packets-Lost_FS1	26	37
38	Acme-Calling-RTP- Avg-Jitter_FS1	26	38
39	Acme-Calling-RTP- MaxJitter_FS1	26	39
40	Acme-Calling- Octets_FS1	26	28
41	Acme-Calling- Packets_FS1	26	29

CSV Placement	Attribute Name	RADIUS ID	Vendor ID
42	Acme-Calling-R-Factor	26	151
43	Acme-Calling-MOS	26	152
44	Acme-FlowID_FS1_R	26	78
45	Acme-FlowType_FS1_R	26	79
46	Acme-Flow-In-Realm_FS1_R	26	80
47	Acme-Flow-In-Src-Addr_FS1_R	26	81
48	Acme-Flow-In-Src-Port_FS1_R	26	82
49	Acme-Flow-In-Dst-Addr_FS1_R	26	83
50	Acme-Flow-In-Dst-Port_FS1_R	26	84
51	Acme-Flow-Out-Realm_FS1_R	26	85
52	Acme-Flow-Out-Src-Addr_FS1_R	26	86
53	Acme-Flow-Out-Src-Port_FS1_R	26	87
54	Acme-Flow-Out-Dst-Addr_FS1_R	26	88
55	Acme-Flow-Out-Dst-Port_FS1_R	26	89
56	Acme-Called-RTCP-Packets-Lost_FS1	26	46
57	Acme-Called-RTCP-Avg-Jitter_FS1	26	47
58	Acme-Called-RTCP-Avg-Latency_FS1	26	48
59	Acme-Called-RTCP-MaxJitter_FS1	26	49
60	Acme-Called-RTCP-MaxLatency_FS1	26	50
61	Acme-Called-RTP-Packets-Lost_FS1	26	51
62	Acme-Called-RTP-Avg-Jitter_FS1	26	52
63	Acme-Called-RTP-MaxJitter_FS1	26	53
64	Acme-Called-Octets_FS1	26	44
65	Acme-Called-Packets_FS1	26	45
66	Acme-Called-R-Factor	26	153
67	Acme-Called-MOS	26	154
68	Acme-FlowID_FS2_F	26	90

CSV Placement	Attribute Name	RADIUS ID	Vendor ID
69	Acme-FlowType_FS2_F	26	91
70	Acme-Flow-In-Realm_FS2_F	26	92
71	Acme-Flow-In-Src-Addr_FS2_F	26	93
72	Acme-Flow-In-Src-Port_FS2_F	26	94
73	Acme-Flow-In-Dst-Addr_FS2_F	26	95
74	Acme-Flow-In-Dst-Port_FS2_F	26	96
75	Acme-Flow-Out-Realm_FS2_F	26	97
76	Acme-Flow-Out-Src-Addr_FS2_F	26	98
77	Acme-Flow-Out-Src-Port_FS2_F	26	99
78	Acme-Flow-Out-Dst-Addr_FS2_F	26	100
79	Acme-Flow-Out-Dst-Port_FS2_F	26	101
80	Acme-Calling-RTCP-Packets-Lost_FS2	26	104
81	Acme-Calling-RTCP-Avg-Jitter_FS2	26	105
82	Acme-Calling-RTCP-Avg-Latency_FS2	26	106
83	Acme-Calling-RTCP-MaxJitter_FS2	26	107
84	Acme-Calling-RTCP-MaxLatency_FS2	26	108
85	Acme-Calling-RTP-Packets-Lost_FS2	26	109
86	Acme-Calling-RTP-Avg-Jitter_FS2	26	110
87	Acme-Calling-RTP-MaxJitter_FS2	26	111
88	Acme-Calling-Octets_FS2	26	102
89	Acme-Calling-Packets_FS2	26	103
90	Acme-FlowID_FS2_R	26	112
91	Acme-FlowType_FS2_R	26	113
92	Acme-Flow-In-Realm_FS2_R	26	114
93	Acme-Flow-In-Src-Addr_FS2_R	26	115
94	Acme-Flow-In-Src-Port_FS2_R	26	116

CSV Placement	Attribute Name	RADIUS ID	Vendor ID
95	Acme-Flow-In-Dst-Addr_FS2_R	26	117
96	Acme-Flow-In-Dst-Port_FS2_R	26	118
97	Acme-Flow-Out-Realm_FS2_R	26	119
98	Acme-Flow-Out-Src-Addr_FS2_R	26	120
99	Acme-Flow-Out-Src-Port_FS2_R	26	121
100	Acme-Flow-Out-Dst-Addr_FS2_R	26	122
101	Acme-Flow-Out-Dst-Port_FS2_R	26	123
102	Acme-Called-RTCP-Packets-Lost_FS2	26	126
103	Acme-Called--RTCP-Avg-Jitter_FS2	26	127
104	Acme-Called--RTCP-Avg-Latency_FS2	26	128
105	Acme-Called--RTCP-MaxJitter_FS2	26	129
106	Acme-Called-RTCP-MaxLatency_FS2	26	130
107	Acme-Called-RTP-Packets-Lost_FS2	26	131
108	Acme-Called-RTP-Avg-Jitter_FS2	26	132
109	Acme-Called-RTP-MaxJitter_FS2	26	133
110	Acme-Called-Octets_FS2	26	124
111	Acme-Called-Packets_FS2	26	125
112	Acme-Session-Charging-Vector	26	N/A
113	Acme-Session-Charging-Function_Address	26	N/A
114	Acme-Firmware-Version	26	56
115	Acme-Local-Time-Zone	26	57
116	Acme-Post-Dial-Delay	26	58
117	Acme-Primary-Routing-Number	26	64
118	Acme-Originating-Trunk-Group	26	N/A
119	Acme-Terminating-Trunk-Group	26	N/A

CSV Placement	Attribute Name	RADIUS ID	Vendor ID
120	Acme-Originating-Trunk-Context	26	N/A
121	Acme-Terminating-Trunk-Context	26	N/A
122	Acme-P-Asserted-ID	26	N/A
123	Acme-Ingress-Local-Addr	26	74
124	Acme-Ingress-Remote-Addr	26	75
125	Acme-Egress-Local-Addr	26	76
126	Acme-Egress-Remote-Addr	26	77
127	Acme-SIP-Diversion	46	63
128	Acme-Intermediate_Time	26	N/A
129	Acct-Session-Time	26	N/A
130	Acme-Egress-Final-Routing-Number	26	N/A
131	Acme-Session-Ingress-RPH	26	N/A
132	Acme-Session-Egress-RPH	26	N/A
133	Acme-Custom-VSA-200	N/A	200
134	Acme-Custom-VSA-201	N/A	201
135	Acme-Custom-VSA-202	N/A	202
136	Acme-Custom-VSA-203	N/A	203
137	Acme-Custom-VSA-204	N/A	204
138	Acme-Custom-VSA-205	N/A	205
139	Acme-Custom-VSA-206	N/A	206
140	Acme-Custom-VSA-207	N/A	207
141	Acme-Custom-VSA-208	N/A	208
142	Acme-Custom-VSA-209	N/A	209
143	Acme-Custom-VSA-210	N/A	219
144	Acme-Custom-VSA-211	N/A	211
145	Acme-Custom-VSA-212	N/A	212

CSV Placement	Attribute Name	RADIUS ID	Vendor ID
146	Acme-Custom-VSA-213	N/A	213
147	Acme-Custom-VSA-214	N/A	214
148	Acme-Custom-VSA-215	N/A	215
149	Acme-Custom-VSA-216	N/A	216
150	Acme-Custom-VSA-217	N/A	217
151	Acme-Custom-VSA-218	N/A	218
152	Acme-Custom-VSA-219	N/A	219
153	Acme-Custom-VSA-220	N/A	220
154	Acme-Custom-VSA-221	N/A	221
155	Acme-Custom-VSA-222	N/A	222
156	Acme-Custom-VSA-223	N/A	223
157	Acme-Custom-VSA-224	N/A	224
158	Acme-Custom-VSA-225	N/A	225
159	Acme-Custom-VSA-226	N/A	226
160	Acme-Custom-VSA-227	N/A	227
161	Acme-Custom-VSA-228	N/A	228
162	Acme-Custom-VSA-229	N/A	229
163	Acme-Custom-VSA-230	N/A	230
164	Acme-Flow-Calling-Media-Stop-Time_FS1	N/A	231
165	Acme-Flow-Called-Media-Stop-Time_FS1	N/A	232
166	Acme-Flow-Calling-Media-Stop-Time_FS2	N/A	233
167	Acme-Flow-Called-Media-Stop-Time_FS2 (234)	N/A	234
168	Acme-CDR-Sequence-Number	N/A	N/A

D

Oracle Rf Interface Support

The OCSBC supports numerous AVPs in its Diameter-based Rf implementation. Currently AVPs belong to:

- The Diameter base AVPs found in RFC3588 and RFC4006.
- For 3GPP AVPs, if not specified by this document, their definition follows corresponding 3GPP specifications.
- Oracle proprietary Rf AVPs. Please see Acme-Packet-Specific-Extension-Rf AVP.

Diameter AVP Notation

3GPP 32.299 states the following symbols are used in the message format definitions:

<AVP> indicates a mandatory AVP with a fixed position in the message.

{AVP} indicates a mandatory AVP in the message.

[AVP] indicates an optional AVP in the message.

*AVP indicates that multiple occurrences of an AVP is possible.

Table Explanation

Each row in the following AVP tables contain:

- AVP Name
- AVP Number
- Reference where the AVP was defined
- Valid appearance in start, interim, stop, or event records
- For grouped AVPs, link to the group's respective section.

Root ACR Message Format

The following table contains the top level AVPs that may be present in an OCSBC-generated message.

AVP	Number	Reference	Start	Interim	Stop	Event	Grouped
{ Session-Id }	263	Base	Y	Y	Y	Y	N/A
{ Origin-Host }	264	Base	Y	Y	Y	Y	N/A
{ Origin-Realm }	296	Base	Y	Y	Y	Y	N/A
{ Destination-Realm }	283	Base	Y	Y	Y	Y	N/A
{ Accounting-Record-Type }	480	Base	Y	Y	Y	Y	N/A

AVP	Number	Reference	Start	Interim	Stop	Event	Grouped
{ Accounting-Record-Number }	485	Base	Y	Y	Y	Y	N/A
[Acct-Application-Id]	259	Base	Y	Y	Y	Y	N/A
[User-Name]	1	Base	Y	Y	Y	Y	N/A
[Origin-state-ID]	278	Base	Y	Y	Y	Y	N/A
[Event-Timestamp]	55	Base	Y	Y	Y	Y	N/A
[Service-Context-ID]	461	3GPP	Y	Y	Y	Y	N/A
[Service-Information]	873	3GPP	Y	Y	Y	Y	Service-Information AVP
[Acme-Packet-Specific-Extension-Rf]	1	ACME	Y	Y	Y		Acme-Packet-Specific-Extension-Rf AVP

Service Information AVP

The Service-Information AVP (AVP code 873) is of type Grouped.

AVP	Number	Reference	Start	Interim	Stop	Event	Grouped
[Subscription-ID]	443	3GPP	Y	Y	Y		Subscription ID AVP
[IMS Information]	876	3GPP	Y	Y	Y	Y	IMS Information AVP

Subscription ID AVP

The Subscription ID AVP (AVP code 108) contains the identification of the user that is going to access the service in order to be identified by the OCS.

AVP	Number	Reference	Start	Interim	Stop	Event
[Subscription-ID-Data]	444	3GPP	Y	Y	Y	N/A
[Subscription-ID-Type]	450	3GPP	Y	Y	Y	N/A

IMS Information AVP

The IMS-Information AVP (AVP code 876) is of type Grouped. Its purpose is to allow the transmission of additional IMS service specific information elements.

AVP	Number	Reference	Start	Interim	Stop	Event	Group
[Event-Type]	823	3GPP	Y	Y	Y	Y	Event-Type AVP
[Role-of-Node]	829	3GPP	Y	Y	Y	Y	N/A

AVP	Number	Reference	Start	Interim	Stop	Event	Group
{Node-Functionality}	862	3GPP	Y	Y	Y	Y	N/A
[User-Session-Id]	830	3GPP	Y	Y	Y	N/A	N/A
* [Calling-Party-Address]	831	3GPP	Y	Y	Y	Y	N/A
[Called-Party-Address]	832	3GPP	Y	Y	Y	Y	N/A
* [Called-Asserted-Identity]	1250	3GPP	Y	N/A	N/A	N/A	N/A
* [Associated-URI]	856	3GPP	N/A	N/A	N/A	Y	N/A
[Time-Stamps]	833	3GPP	Y	Y	Y	Y	Time Stamps AVP
[Inter-Operator-Identifier]	838	3GPP	Y	Y	Y	N/A	Inter-Operator-Identifier AVP
*[SDP-Session-Description]	842	3GPP	Y	Y	N/A	N/A	N/A
*[SDP-Media-Component]	843	3GPP	Y	Y	N/A	N/A	SDP-Media-Component AVP
[IMS-Charging-Identifier]	841	3GPP	Y	Y	Y	N/A	N/A
*[Early-Media-Description]	1272	3GPP	Y	N/A	N/A	Y	Early-Media-Description AVP
*[Message-Body]	889	3GPP	Y	Y	Y	Y	Message-Body AVP
[Served-Party-IP-Address]	848	3GPP	Y*	Y*	Y*	N/A	N/A
[Access-Network-Information]	1263	N/A	Y	Y	Y	Y	N/A
[Cause-Code]	861	N/A	N/A	N/A	Y	Y	N/A

Y*—This AVP appears if **sip-interface**, **sip-ims-feature** is set to **enabled**.

Event-Type AVP

The Event-Type AVP (AVP code 823) is of type Grouped and contains information about the type of chargeable telecommunication service/event for which the accounting-request and/or credit control request message(s) is generated.

AVP	Number	Acme #	Reference	Start	Interim	Stop	Event
[SIP-Method]	824	173	3GPP	Y	Y	Y	Y
[Event]	825	245	3GPP	N/A	N/A	N/A	Y
[Expires]	888	246	3GPP	N/A	N/A	N/A	Y

Time Stamps AVP

The Time-Stamps AVP (AVP code 833) is of type Grouped and holds the time of the initial SIP request and the time of the response to the initial SIP Request.

AVP	Number	Reference	Start	Interim	Stop	Event
[SIP-Request-Timestamp]	834	3GPP	Y	Y	Y	Y
[SIP-Response-Timestamp]	835	3GPP	Y*	Y	Y	Y
[SIP-Request-Timestamp-Fraction]	2301	3GPP	Y	Y	Y	Y
[SIP-Response-Timestamp-Fraction]	2302	3GPP	Y*	Y	Y	Y

Y*—These AVPs appear in start records if **account-config, generate-start** is set to **OK**. If generate-start=invite, then they are not generated in the Start record.

Inter-Operator-Identifier AVP

The Inter-Operator-Identifier AVP (AVP code 838) is of type Grouped and holds the identification of the network neighbors (originating and terminating) as exchanged via SIP signalling.

AVP	Number	Reference	Start	Interim	Stop	Event
[Originating-IOI]	839	3GPP	Y	Y	Y	N/A
[Termination-IOI]	840	3GPP	Y*	Y	Y	N/A

Y*—These AVPs appear in start records if **account-config, generate-start** is set to **OK**.

SDP-Media-Component AVP

The SDP- Media-Component AVP (AVP code 843) is of type Grouped and contains information about media used for a IMS session.

AVP	Number	Reference	Start	Interim	Stop	Event
[SDP-Media-Name]	844	3GPP	Y	Y	N/A	N/A
* [SDP-Media-Description]	845	3GPP	Y	Y	N/A	N/A
[SDP-Type]	2036	3GPP	Y	Y	N/A	N/A

Early-Media-Description AVP

The Early-Media-Description AVP (AVP code 1272) is of type grouped and describes the SDP session, media parameters and timestamps related to media components set to active according to SDP signalling exchanged during a SIP session establishment before the final successful or unsuccessful SIP answer to the initial SIP INVITE message is received. Once a media component has been set to active, subsequent status changes shall also be registered.

AVP	Number	Reference	Start	Interim	Stop	Event	Group
[SDP-TimeStamps]	1273	3GPP	Y	N/A	N/A	Y	SDP-Timestamps AVP
*[SDP-Session-Description]	842	3GPP	Y	Y	N/A	N/A	N/A
*[SDP-Media-Component]	843	3GPP	Y	Y	N/A	N/A	SDP-Media-Component AVP

SDP-Timestamps AVP

The SDP-TimeStamps AVP (AVP code 1273) is of type Grouped and holds the time of the SDP offer and the SDP answer.

AVP	Number	Reference	Start	Interim	Stop	Event
[SDP-Offer-Timestamp]	1274	N/A	Y	N/A	N/A	Y
[SDP-Answer-Timestamp]	1275	N/A	Y	N/A	N/A	Y

Message-Body AVP

The Message-Body AVP (AVP Code 889) is of type Grouped AVP and holds information about the message bodies including user-to-user data.

AVP	Number	Reference	Start	Interim	Stop	Event
{ Content-Type }	826	3GPP	Y	Y	Y	Y
{ Content-Length }	827	3GPP	Y	Y	Y	Y
[Content-Disposition]	828	3GPP	Y	Y	Y	Y
[Originator]	864	3GPP	Y	Y	Y	Y

Acme-Packet-Specific-Extension-Rf AVP

The Oracle Acme-Packet-Specific-Extension-Rf AVP uses vendor ID 9148. The following section includes the ACME AVP descriptions.

AVP	ACME Diameter Attribute	Start	Interim	Stop	Event	AVP Type
Ingress-Realm	2	Y	Y	Y	N	UTF8String
Egress-Realm	3	Y	Y	Y	N	UTF8String
Ingress-TGRP	4	Y	Y	Y	N	UTF8String
Egress-TGRP	5	Y	Y	Y	N	UTF8String
Ingress-Trunk-Context	6	Y	Y	Y	N	UTF8String

AVP	ACME Diameter Attribute	Start	Interim	Stop	Event	AVP Type
Egress-Trunk-Context	7	N	Y	Y	N	UTF8String
Ingress-Local-Signaling-Address	8	Y	Y	Y	N	UTF8String
Ingress-Remote-Signaling-Address	9	Y	Y	Y	N	UTF8String
Egress-Local-Signaling-Address	10	Y	Y	Y	N	UTF8String
Egress-Remote-Signaling-Address	11	Y	Y	Y	N	UTF8String
Ingress-Local-Media-Address	12	Y	Y	Y	N	UTF8String
Ingress-Remote-Media-Address	13	Y	Y	Y	N	UTF8String
Egress-Local-Media-Address	14	Y	Y	Y	N	UTF8String
Egress-Remote-Media-Address	15	Y	Y	Y	N	UTF8String
NAS-Port	16	Y	Y	Y	N	Unsigned32
Acme-Session-Ingress-CallID	17	Y	Y	Y	N	UTF8String
Acme-Session-Egress-CallID	18	Y	Y	Y	N	UTF8String
Acme-Session-Protocol-Type	19	Y	Y	Y	N	UTF8String
Acme-FlowID-FS1-F	20	Y	Y	Y	N	UTF8String
Acme-FlowType-FS1-F	21	Y	Y	Y	N	UTF8String
Ingress-Local-Media-Port	22	Y	Y	Y	N	Unsigned32
Ingress-Remote-Media-Port	23	Y	Y	Y	N	Unsigned32
Egress-Local-Media-Port	24	Y	Y	Y	N	Unsigned32
Egress-Remote-Media-Port	25	Y	Y	Y	N	Unsigned32
Acme-Session-Charging-Function-Address	26	Y	Y	Y	N	UTF8String
Acme-Local-Timezone	27	Y	Y	Y	N	UTF8String
Acme-Post-Dial-Delay	28	Y	Y	Y	N	Unsigned32
Acme-SIP-Diversion	29	Y	Y	Y	N	UTF8String

AVP	ACME Diameter Attribute	Start	Interim	Stop	Event	AVP Type
Acme-Session-Disposition	30	N	N	Y	N	Unsigned32
Disconnect-Initiator	31	N	N	Y	N	Unsigned32
Terminate-Cause	32	N	N	Y	N	Unsigned32
Acme-Session-Disconnect-Cause	33	N	N	Y	N	Unsigned32
Acme-SIP-Status	34	N	N	Y	N	Integer32
Acme-FlowType-FS1-R	35	N	Y	Y	N	UTF8String
Acme-Packet-Specific-Rf-QoS	37	N	N	Y	N	Grouped
RTP-Calling-Octets-FS1	38	N	N	Y	N	Unsigned32
RTP-Calling-Octets-FS2	39	N	N	Y	N	Unsigned32
RTP-Calling-Packets-FS1	40	N	N	Y	N	Unsigned32
RTP-Calling-Packets-FS2	41	N	N	Y	N	Unsigned32
RTP-Calling-Octets-Transmitted-FS1	42	N	N	Y	N	Unsigned32
RTP-Calling-Octets-Transmitted-FS2	43	N	N	Y	N	Unsigned32
RTP-Calling-Packets-Transmitted-FS1	44	N	N	Y	N	Unsigned32
RTP-Calling-Packets-Transmitted-FS2	45	N	N	Y	N	Unsigned32
RTP-Calling-Packets-Lost-FS1	46	N	N	Y	N	Unsigned32
RTP-Calling-Packets-Lost-FS2	47	N	N	Y	N	Unsigned32
RTP-Calling-Avg-Jitter-FS1	48	N	N	Y	N	Unsigned32
RTP-Calling-Avg-Jitter-FS2	49	N	N	Y	N	Unsigned32
RTP-Calling-Max-Jitter-FS1	50	N	N	Y	N	Unsigned32
RTP-Calling-Max-Jitter-FS2	51	N	N	Y	N	Unsigned32
RTCP-Calling-Packets-Lost-FS1	52	N	N	Y	N	Unsigned32
RTCP-Calling-Packets-Lost-FS2	53	N	N	Y	N	Unsigned32

AVP	ACME Diameter Attribute	Start	Interim	Stop	Event	AVP Type
RTCP-Calling-Avg-Jitter-FS1	54	N	N	Y	N	Unsigned32
RTCP-Calling-Avg-Jitter-FS2	55	N	N	Y	N	Unsigned32
RTCP-Calling-Avg-Latency-FS1	56	N	N	Y	N	Unsigned32
RTCP-Calling-Avg-Latency-FS2	57	N	N	Y	N	Unsigned32
RTCP-Calling-Max-Jitter-FS1	58	N	N	Y	N	Unsigned32
RTCP-Calling-Max-Jitter-FS2	59	N	N	Y	N	Unsigned32
RTCP-Calling-Max-Latency-FS1	60	N	N	Y	N	Unsigned32
RTCP-Calling-Max-Latency-FS2	61	N	N	Y	N	Unsigned32
RTP-Called-Octets-FS1	62	N	N	Y	N	Unsigned32
RTP-Called-Octets-FS2	63	N	N	Y	N	Unsigned32
RTP-Called-Packets-FS1	64	N	N	Y	N	Unsigned32
RTP-Called-Packets-FS2	65	N	N	Y	N	Unsigned32
RTP-Called-Octets-Transmitted-FS1	66	N	N	Y	N	Unsigned32
RTP-Called-Octets-Transmitted-FS2	67	N	N	Y	N	Unsigned32
RTP-Called-Packets-Transmitted-FS1	68	N	N	Y	N	Unsigned32
RTP-Called-Packets-Transmitted-FS2	69	N	N	Y	N	Unsigned32
RTP-Called-Packets-Lost-FS1	70	N	N	Y	N	Unsigned32
RTP-Called-Packets-Lost-FS2	71	N	N	Y	N	Unsigned32
RTP-Called-Avg-Jitter-FS1	72	N	N	Y	N	Unsigned32
RTP-Called-Avg-Jitter-FS2	73	N	N	Y	N	Unsigned32
RTP-Called-Max-Jitter-FS1	74	N	N	Y	N	Unsigned32
RTP-Called-Max-Jitter-FS2	75	N	N	Y	N	Unsigned32
RTCP-Called-Packets-Lost-FS1	76	N	N	Y	N	Unsigned32

AVP	ACME Diameter Attribute	Start	Interim	Stop	Event	AVP Type
RTCP-Called-Packets-Lost-FS2	77	N	N	Y	N	Unsigned32
RTCP-Called-Avg-Jitter-FS1	78	N	N	Y	N	Unsigned32
RTCP-Called-Avg-Jitter-FS2	79	N	N	Y	N	Unsigned32
RTCP-Called-Avg-Latency-FS1	80	N	N	Y	N	Unsigned32
RTCP-Called-Avg-Latency-FS2	81	N	N	Y	N	Unsigned32
RTCP-Called-Max-Jitter-FS1	82	N	N	Y	N	Unsigned32
RTCP-Called-Max-Jitter-FS2	83	N	N	Y	N	Unsigned32
RTCP-Called-Max-Latency-FS1	84	N	N	Y	N	Unsigned32
RTCP-Called-Max-Latency-FS2	85	N	N	Y	N	Unsigned32
Acme-Packets-Specific-MSRP-STATS	86	N	N	Y	N	Grouped
MSRP-Calling-Packets-Received	87	N	N	Y	N	Unsigned32
MSRP-Calling-Octets-Received	88	N	N	Y	N	Unsigned32
MSRP-Calling-Packets-Transmitted	89	N	N	Y	N	Unsigned32
MSRP-Calling-Octets-Transmitted	90	N	N	Y	N	Unsigned32
MSRP-Called-Packets-Received	91	N	N	Y	N	Unsigned32
MSRP-Called-Octets-Received	92	N	N	Y	N	Unsigned32
MSRP-Called-Packets-Transmitted	93	N	N	Y	N	Unsigned32
MSRP-Called-Octets-Transmitted	94	N	N	Y	N	Unsigned32

AVP Definitions

The following table lists and briefly describes the Acme-Packet-Specific-Extension-Rf AVPs.

AVP	Definition
Ingress-Realm	realm of origination
Egress-Realm	realm of termination
Ingress-TGRP	TGRP received
Egress-TGRP	TGRP sent
Ingress-Trunk-Context	trunk context received
Egress-Trunk-Context	trunk context sent
Ingress-Local-Signaling-Address	Signaling address of P-CSCF that received the request from the remote element
Ingress-Remote-Signaling-Address	Signaling address of the remote element that sent the request to the P-CSCF
Egress-Local-Signaling-Address	Signaling address of P-CSCF that sent the request to the remote element
Egress-Remote-Signaling-Address	signaling address of the remote element that received the request from the P-CSCF
Ingress-Local-Media-Address	media address of P-CSCF on the originating side
Ingress-Remote-Media-Address	media address of the remote element on the originating side
Egress-Local-Media-Address	media address of P-CSCF on the terminating side
Egress-Remote-Media-Address	media address of the remote element on the terminating side
NAS-Port	SIP proxy port or the H.323 stack's call signaling RAS port.
Acme-Session-Ingress-CallID	Call ID generated by the originating device.
Acme-Session-Egress-CallID	Call ID generated by the OCSBC to represent a two-way transaction.
Acme-Session-Protocol-Type	Signaling protocol used for a particular leg of a session (in the case of IWF, there may be two legs). This attribute contains the signaling protocol type; for example, SIP or H323.
Acme-FlowID-FS1-F	Unique identifier for every media flow processed by the OCSBC, flow-set 1 forward direction.
Acme-FlowType-FS1-F	Codec that describes the flow, flow-set 1 forward direction: PCMU, PCMA, G726, G723, G728, G729, H261, H263, T38.
Ingress-Local-Media-Port	Ingress port portion of address of P-CSCF on the originating side
Ingress-Remote-Media-Port	Ingress port portion of media address of the remote element on the originating side
Egress-Local-Media-Port	Egress port portion of address of P-CSCF on the terminating side
Egress-Remote-Media-Port	Egress port portion of media address of the remote element on the terminating side
Acme-Session-Charging-Function-Address	The latest cached copy or the configured ccf-address.
Acme-Local-Timezone	Local GMT/UTC time zone that is provisioned on the OCSBC.

AVP	Definition
Acme-Post-Dial-Delay	Amount of time between session initiation and an alerting event.
Acme-SIP-Diversion	SIP Diversion header; communicates to the called party from whom and why a call diverted.
Acme-Session-Disposition	Status of the call attempt as it progresses from being initiated (using a SIP INVITE or H.323 Setup message) to being either answered or failing to be answered.
Disconnect-Initiator	Initiator of a call disconnect.
Terminate-Cause	Reason for session ending (refer to Session Termination session).
Acme-Session-Disconnect-Cause	Q.850 cause code value.
Acme-SIP-Status	SIP status code for RFC 3326 support.
Acme-FlowType-FS1-R	Codec that describes the flow, flow-set 1 reverse direction: PCMU, PCMA, G726, G723, G728, G729, H261, H263, T38.
RTP-Calling-Octets-FS1	RTP total calling octets for stream 1
RTP-Calling-Octets-FS2	RTP total calling octets for stream 2
RTP-Calling-Packets-FS1	RTP total calling packets for stream 1
RTP-Calling-Packets-FS2	RTP total calling packets for stream 2
RTP-Calling-Octets-Transmitted-FS1	RTP calling octets transmitted for stream 1
RTP-Calling-Octets-Transmitted-FS2	RTP calling octets transmitted for stream 2
RTP-Calling-Packet-Transmitted-FS1	RTP calling packets transmitted for stream 1
RTP-Calling-Packet-Transmitted-FS2	RTP calling packets transmitted for stream 2
RTP-Calling-Packets-Lost-FS1	RTP calling packets lost for stream 1
RTP-Calling-Packets-Lost-FS2	RTP calling packets lost for stream 2
RTP-Calling-Avg-Jitter-FS1	RTP calling average jitter rate for stream 1
RTP-Calling-Avg-Jitter-FS2	RTP calling average jitter rate for stream 2
RTP-Calling-Max-Jitter-FS1	RTP calling maximum jitter rate for stream 1
RTP-Calling-Max-Jitter-FS2	RTP calling maximum jitter rate for stream 2
RTCP-Calling-Packets-Lost-FS1	RTCP calling packet lost rate for stream 1
RTCP-Calling-Packets-Lost-FS2	RTCP calling packet lost rate for stream 2
RTCP-Calling-Avg-Jitter-FS1	RTCP calling average jitter rate for stream 1
RTCP-Calling-Avg-Jitter-FS2	RTCP calling average jitter rate for stream 2
RTCP-Calling-Avg-Latency-FS1	RTCP calling average latency for stream 1
RTCP-Calling-Avg-Latency-FS2	RTCP calling average latency for stream 2
RTCP-Calling-Max-Jitter-FS1	RTCP calling maximum jitter rate for stream 1
RTCP-Calling-Max-Jitter-FS2	RTCP calling maximum jitter rate for stream 2
RTCP-Calling-Max-Latency-FS1	RTCP calling maximum latency rate for stream 1
RTCP-Calling-Max-Latency-FS2	RTCP calling maximum latency rate for stream 2
RTP-Called-Octets-FS1	RTP called total octets for stream 1
RTP-Called-Octets-FS2	RTP called total octets for stream 2
RTP-Called-Packets-FS1	RTP called total packets for stream 1
RTP-Called-Packets-FS2	RTP called total packets for stream 2
RTP-Called-Octets-Transmitted-FS1	RTP called octets transmitted for stream 1

AVP	Definition
RTP-Called-Octets-Transmitted-FS2	RTP called octets transmitted for stream 2
RTP-Called-Packets-Transmitted-FS1	RTP called packets transmitted for stream 1
RTP-Called-Packets-Transmitted-FS2	RTP called packets transmitted for stream 2
RTP-Called-Packets-Lost-FS1	RTP called packets lost for stream 1
RTP-Called-Packets-Lost-FS2	RTP called packets lost for stream 2
RTP-Called-Avg-Jitter-FS1	RTP called average jitter for stream 1
RTP-Called-Avg-Jitter-FS2	RTP called average jitter for stream 2
RTP-Called-Max-Jitter-FS1	RTP called maximum jitter for stream 1
RTP-Called-Max-Jitter-FS2	RTP called maximum jitter for stream 2
RTCP-Called-Packets-Lost-FS1	RTCP called packets lost for stream 1
RTCP-Called-Packets-Lost-FS2	RTCP called packets lost for stream 2
RTCP-Called-Avg-Jitter-FS1	RTCP called average jitter for stream 1
RTCP-Called-Avg-Jitter-FS2	RTCP called average jitter for stream 2
RTCP-Called-Avg-Latency-FS1	RTCP called average latency for stream 1
RTCP-Called-Avg-Latency-FS2	RTCP called average latency for stream 2
RTCP-Called-Max-Jitter-FS1	RTCP called maximum jitter for stream 1
RTCP-Called-Max-Jitter-FS2	RTCP called maximum jitter for stream 2
RTCP-Called-Max-Latency-FS1	RTCP called maximum latency for stream 1
RTCP-Called-Max-Latency-FS2	RTCP called maximum latency for stream 2
Acme-MSRP-Calling-Packets-Received	Total MSRP calling packets
Acme-MSRP-Calling-Octets-Received	Total MSRP calling octets
Acme-MSRP-Calling-Packets-Transmitted	Total MSRP calling transmitted packets
Acme-MSRP-Calling-Octets-Transmitted	Total MSRP calling transmitted octets
Acme-MSRP-Called-Packets-Received	Total MSRP called packets
Acme-MSRP-Called-Octets-Received	Total MSRP called octets
Acme-MSRP-Called-Packets-Transmitted	Total MSRP called transmitted packets
Acme-MSRP-Called-Octets-Transmitted	Total MSRP called transmitted octets

System Alarming Based on Received Result-Code (268) AVP

All non-success (non 2xxx) result codes received are logged and the OCSBC raises an internal minor alarm, sending the apDiameterSvrErrorResultTrap SNMP trap to any configured trap receiver for the following values in the ACA message's Result-Code (268) AVP:

- 3002
- 3004
- 4002
- 5012

For more information, see the *MIB Reference Guide*. The OCSBC uses DWR mechanism for failover purposes - not based on result codes.

The OCSBC expects this AVP in an ACA message to follow:

AVP	Number	AVP Type	Reference	Start	Interim	Stop	Event
[Result-Code]	268	Unsigned32	Base	Y	Y	Y	Y

Interim ACR Message Creation Interval per Acct-Interim-Interval AVP

The ACA message's Acct-Interim-Interval AVP (85) indicates the interval at which the OCSBC sends INTERIM ACR messages. The value provided in the CCF's ACA overrides any configured Acct-Interim-Interval in the network element.

The OCSBC expects this AVP in an ACA message to follow:

AVP	Number	AVP Type	Reference	Start	Interim	Stop	Event
[Acct-Interim-Interval AVP]	85	Unsigned32	Base	Y	Y	Y	Y