

Interactive Session Recorder

Administrator Guide



Release 6.4
F29532-05
December 2022

The Oracle logo, consisting of a solid red square with the word "ORACLE" in white, uppercase, sans-serif font centered within it.

ORACLE®

Copyright © 2014, 2022, Oracle and/or its affiliates.

This software and related documentation are provided under a license agreement containing restrictions on use and disclosure and are protected by intellectual property laws. Except as expressly permitted in your license agreement or allowed by law, you may not use, copy, reproduce, translate, broadcast, modify, license, transmit, distribute, exhibit, perform, publish, or display any part, in any form, or by any means. Reverse engineering, disassembly, or decompilation of this software, unless required by law for interoperability, is prohibited.

The information contained herein is subject to change without notice and is not warranted to be error-free. If you find any errors, please report them to us in writing.

If this is software, software documentation, data (as defined in the Federal Acquisition Regulation), or related documentation that is delivered to the U.S. Government or anyone licensing it on behalf of the U.S. Government, then the following notice is applicable:

U.S. GOVERNMENT END USERS: Oracle programs (including any operating system, integrated software, any programs embedded, installed, or activated on delivered hardware, and modifications of such programs) and Oracle computer documentation or other Oracle data delivered to or accessed by U.S. Government end users are "commercial computer software," "commercial computer software documentation," or "limited rights data" pursuant to the applicable Federal Acquisition Regulation and agency-specific supplemental regulations. As such, the use, reproduction, duplication, release, display, disclosure, modification, preparation of derivative works, and/or adaptation of i) Oracle programs (including any operating system, integrated software, any programs embedded, installed, or activated on delivered hardware, and modifications of such programs), ii) Oracle computer documentation and/or iii) other Oracle data, is subject to the rights and limitations specified in the license contained in the applicable contract. The terms governing the U.S. Government's use of Oracle cloud services are defined by the applicable contract for such services. No other rights are granted to the U.S. Government.

This software or hardware is developed for general use in a variety of information management applications. It is not developed or intended for use in any inherently dangerous applications, including applications that may create a risk of personal injury. If you use this software or hardware in dangerous applications, then you shall be responsible to take all appropriate fail-safe, backup, redundancy, and other measures to ensure its safe use. Oracle Corporation and its affiliates disclaim any liability for any damages caused by use of this software or hardware in dangerous applications.

Oracle®, Java, and MySQL are registered trademarks of Oracle and/or its affiliates. Other names may be trademarks of their respective owners.

Intel and Intel Inside are trademarks or registered trademarks of Intel Corporation. All SPARC trademarks are used under license and are trademarks or registered trademarks of SPARC International, Inc. AMD, Epyc, and the AMD logo are trademarks or registered trademarks of Advanced Micro Devices. UNIX is a registered trademark of The Open Group.

This software or hardware and documentation may provide access to or information about content, products, and services from third parties. Oracle Corporation and its affiliates are not responsible for and expressly disclaim all warranties of any kind with respect to third-party content, products, and services unless otherwise set forth in an applicable agreement between you and Oracle. Oracle Corporation and its affiliates will not be responsible for any loss, costs, or damages incurred due to your access to or use of third-party content, products, or services, except as set forth in an applicable agreement between you and Oracle.

Contents

About This Guide

My Oracle Support x

Revision History

1 Overview

About the ISR	1-1
Session Recording Client Support	1-2
Selective Call Recording SIPREC	1-2
SIPREC for Active Recording	1-3
Preserve SIPREC with SIP REFER Header	1-4
Configuring SIPREC	1-4
ISR FACE	1-4
About the ISR Dashboard	1-5
Requirements	
Recommendations	1-5
Security Features	1-6

2 Getting Started

Logging In/Out of the ISR Dashboard	2-1
User Access Levels	2-4
Help Link	2-5
Dashboard Settings	2-6
Recordings List Settings	2-8
RSS View Settings	2-9
Change Password	2-9
Dashboard Tools	2-9
Paging Tool	2-10
Search Tools	2-10
Basic Search for Recordings	2-10

Advanced Search for Recordings	2-11
Basic Search for Routes	2-16
Column Sorting Tool	2-17
Download Tool	2-17
Downloading a Single Recording File	2-17
Downloading a Recording List to a CSV File	2-18
Import Link	2-20
Administrator Menu	2-21

3 Managing Accounts

Managing Accounts	3-1
Adding an Account	3-2
Configuring/Editing Details for an Account	3-3
Edit Account Configurations	3-3
Archival Configurations	3-5
Dashboard Configurations	3-8
Permissions	3-10
Route Defaults	3-10
Routes	3-14
Users	3-14
Video	3-14
LDAP Configurations	3-15
Deleting an Account	3-15
Importing an Account CSV File	3-16

4 Managing Users

Manage Users	4-1
User Access Levels	4-2
Adding a User	4-2
Editing a User Profile	4-5
Showing User Activity	4-6
Deleting a User	4-7
Importing a User Profile CSV File	4-7

5 Managing Realms

Managing Realms	5-1
How Realm-based Recording Works	5-1
Adding a Realm	5-3
Associating an Account to a Realm	5-3

Editing a Realm	5-4
Deleting a Realm	5-4

6 Managing Routes

Manage Routes	6-1
Adding a Route	6-2
Examples of Route Patterns	6-3
Configuring and Editing Details of a Route	6-5
Edit General Route Information	6-5
Route Advanced Configurations	6-6
Recording	6-7
Video	6-8
Recording Notes and Scoring Permissions	6-8
Record and Save Mode	6-8
Archiving	6-8
Capacity	6-9
Route Members	6-9
Adding a Route to a Route Group	6-9
Deleting a Route	6-10
Importing a Route CSV File	6-11

7 Managing Authorization Services

Manage Authorization Services	7-1
Adding an Authorization Service	7-2
Editing an Authorization Service	7-3
Deleting an Authorization Service	7-4

8 Custom Data

Viewing and Editing the Custom Data Master List	8-1
Viewing and Editing Custom Data Field Session Values	8-2
Custom Data Fields Advanced Search	8-2

9 External Event Destinations

External Event Notifications	9-1
Configuring External Event Destinations	9-1
External Event Configuration Example	9-2

10 Managing Locales

Manage Locales	10-1
Adding a New Locale	10-1

11 Managing Recording Format Profiles

Editing a Recording Format Profile	11-1
Recording Format Mappings Configuration	11-2
Applying Recording Format Profiles to Accounts	11-2
Applying Recording Format Profiles to Routes	11-3
Route Recording File Permissions	11-4

12 Managing Security Settings

13 Managing Template Definitions

Template Definitions	13-1
Formatting	13-1
Field Parameters	13-1
Adding a New Template	13-3
Recordings with No Media	13-4

14 Viewing Live Sessions

Manage Live Sessions	14-1
----------------------	------

15 Managing Sites

Manage Sites	15-1
Adding a Site	15-2
Managing an RSS	15-3
Sites Recorders Page	15-3
Adding an RSS	15-4
Editing a Recorder	15-4
Deleting an RSS	15-8
Managing an RSS Location	15-9
Adding a Location	15-9
Editing a Location	15-12
Deleting a Location	15-13

Managing Archivers	15-13
Adding an Archiver	15-14
Editing an Archiver	15-16
Deleting an Archiver	15-17

16 Managing Recordings

Manage Recordings	16-1
Playing a Recording	16-2
Viewing and Editing Details of a Recording	16-3
Viewing Recording Details	16-4
Viewing Recording Details Recorder and RSS Information	16-4
Notes and Scoring	16-5
Recording Details File Location	16-6
Recording Details Custom Data	16-6
Segment Details Configuration	16-6
Segment Recording Details Custom Data	16-7
Segment Session Metadata	16-7
Segment Session Participant Metadata	16-8
Displaying DTMF Data in Segment Details: Routes	16-9
Displaying DTMF Data in Segment Details: Accounts	16-9
Displaying DTMF Data in Segment Details	16-10
Deleting a Recording	16-11

17 Managing Reports

Manage Reports	17-1
Usage Reports	17-1
Generating a Usage Report	17-2
Generating a report by month	17-2
Generating a report by range	17-2
Selecting a route	17-3
Usage Report Bar Graph Descriptions	17-3
Billing Reports	17-5
Generating a Billing Report	17-6
Generating a Report by Month	17-6
Generating a Report by Range	17-6
Selecting a Route	17-7
Billing Report Bar Graph Descriptions	17-7

A Software Diagrams and Call Setup Sequence

ISR Recorder Process Architecture Diagram	A-1
Description of Components	A-1
Record Store Server (RSS)	A-1
Control Index Server (CIS)	A-2
Sequence Diagrams	A-3
Non-SIPREC Call	A-3
ISR Call Setup Sequence Diagram	A-3
SIPREC Call	A-3

B ISR Linux Users and File Permissions

ISR Third-Party Platform File Permissions	B-3
---	-----

C ISR Dashboard Database Failover

Configuring ISR Dashboard Database High Availability	C-1
--	-----

D Logging Into ObserveIT Visual Session Recording

E ISR Accessibility Features

Using General Keyboard Shortcuts	E-1
Using the Keyboard with Tables	E-2
Using the Keyboard to Work with Page Controls	E-3
Buttons	E-4
Calendar	E-4
Navigation Lists	E-6
Toggle Switch	E-7
Train Stops	E-7

About This Guide

The Interactive Session Recorder (ISR) Administrator Guide provides information including:

- Overview of the ISR and getting started
- Managing and configuring the various components of the ISR Dashboard, including accounts, routes, users, sites, RSS servers, system configurations, accessing recordings, and building reports
- Software diagrams and call setup sequence
- ISR Linux Users and File Permissions
- ISR Dashboard Database Failover
- Accessing ObserveIT Visual Session Recording

Related Documentation

The following table describes the documentation set for this release.

Document Name	Document Description
ISR Release Notes	Contains information about new ISR features, fixes, and known issues.
ISR Installation Guide	Provides an overview of the ISR, hardware/software requirements and recommendations, storage considerations, pre-installation information, installation procedures, post-install verification procedures, making the first call, and additional advanced topics about the ISR.
ISR User Guide	Contains information about using the ISR Dashboard for all levels of users. Provides information about viewing, playing, deleting recordings, running reports, and managing user profiles.
ISR Administrator Guide	Contains information about using the ISR Dashboard for the Administrator level user (Super User, Account Administrator, Tenant Administrator). Provides information about creating and managing accounts, routes, and users. Also provides information about configuring the ISR, running reports, viewing active calls, and securing the ISR deployment.
ISR API Reference Guide	Contains information about ISR FACE, VoiceXML Commands, legacy application programming interfaces (APIs), Recording File Types/Formats Supported, Return Codes, sendIPCRCommand.jsp Subdialog, Advanced Options, and Troubleshooting.

Document Name	Document Description
ISR Monitoring Guide	Contains information about installing and configuring the ISR Monitor, the Monitor database schema, and the Monitor MIB.
ISR Security Guide	Contains information about security considerations and best practices from a network and application security perspective for the ISR product.

My Oracle Support

My Oracle Support (<https://support.oracle.com>) is your initial point of contact for all product support and training needs. A representative at Customer Access Support (CAS) can assist you with My Oracle Support registration.

Call the CAS main number at 1-800-223-1711 (toll-free in the US), or call the Oracle Support hotline for your local country from the list at <http://www.oracle.com/us/support/contact/index.html>. When calling, make the selections in the sequence shown below on the Support telephone menu:

1. Select 2 for New Service Request.
2. Select 3 for Hardware, Networking, and Solaris Operating System Support.
3. Select one of the following options:
 - For technical issues such as creating a new Service Request (SR), select 1.
 - For non-technical issues such as registration or assistance with My Oracle Support, select 2.

You are connected to a live agent who can assist you with My Oracle Support registration and opening a support ticket.

My Oracle Support is available 24 hours a day, 7 days a week, 365 days a year.

Emergency Response

In the event of a critical service situation, emergency response is offered by the Customer Access Support (CAS) main number at 1-800-223-1711 (toll-free in the US), or call the Oracle Support hotline for your local country from the list at <http://www.oracle.com/us/support/contact/index.html>. The emergency response provides immediate coverage, automatic escalation, and other features to ensure that the critical situation is resolved as rapidly as possible.

A critical situation is defined as a problem with the installed equipment that severely affects service, traffic, or maintenance capabilities, and requires immediate corrective action. Critical situations affect service and/or system operation resulting in one or several of these situations:

- A total system failure that results in loss of all transaction processing capability
- Significant reduction in system capacity or traffic handling capability
- Loss of the system's ability to perform automatic system reconfiguration
- Inability to restart a processor or the system
- Corruption of system databases that requires service affecting corrective actions

- Loss of access for maintenance or recovery operations
- Loss of the system ability to provide any required critical or major trouble notification

Any other problem severely affecting service, capacity/traffic, billing, and maintenance capabilities may be defined as critical by prior discussion and agreement with Oracle.

Locate Product Documentation on the Oracle Help Center Site

Oracle Communications customer documentation is available on the web at the Oracle Help Center (OHC) site, <http://docs.oracle.com>. You do not have to register to access these documents. Viewing these files requires Adobe Acrobat Reader, which can be downloaded at <http://www.adobe.com>.

1. Access the Oracle Help Center site at <http://docs.oracle.com>.
2. Click **Industries**.
3. Under the Oracle Communications sub-header, click the **Oracle Communications documentation** link.
The Communications Documentation page appears. Most products covered by these documentation sets appear under the headings "Network Session Delivery and Control Infrastructure" or "Platforms."
4. Click on your Product and then Release Number.
A list of the entire documentation set for the selected product and release appears.
5. To download a file to your location, right-click the **PDF** link, select **Save target as** (or similar command based on your browser), and save to a local folder.

Revision History

This section provides a revision history for this document.

Date	Description
March 2020	<ul style="list-style-type: none"> Initial release of ISR 6.4 software.
July 2020	<ul style="list-style-type: none"> Updates "Template Definitions" to include information about already existing templates. Updates "Adding a New Template" to include a note about already existing templates. Updates "Basic Search for Recordings" to include Label value in which to search. Updates "Downloading a Recording List to a CSV File" for clarity regarding custom data fields. Updates the screenshot in "Displaying DTMF Data in Segment Details".
November 2020	<ul style="list-style-type: none"> Updates "Logging In/Out of the ISR Dashboard" and "Importing a User Profile CSV File" with a note regarding username case-sensitivity. Updates the "Managing an RSS Location", "Adding a Location" topic with the Access type, SFTP Port option. Updates the following topics for clarity: <ul style="list-style-type: none"> Advanced Search for Recordings Showing User Activity Managing Security Settings Archival Configurations Troubleshooting Archival

Date	Description
February 2021	<ul style="list-style-type: none">• Includes note in the following sections regarding CSV file values:<ul style="list-style-type: none">– Importing an Account CSV File– Importing a User Profile CSV File– Importing a Route CSV File• Updates "Manage Live Sessions" to include a new screenshot and a note about the Refresh button.• Updates "Archival Configurations" to include SFTP Port Access Type.• Updates "Basic Search for Recordings" and "Advanced Search for Recordings" for clarity.• From the "Managing Sites, Editing a Recorder, Recording Configurations" section, removes the AMR-WB Concurrent Sessions option.• Updates the description in "Downloading a Recording List to a CSV File".
December 2022	<ul style="list-style-type: none">• Updates "User Access Levels" and "Administrator Menu" for accuracy.

1

Overview

This chapter provides an overview of the ISR. It also provides information about using the ISR Dashboard to access and configure the ISR, and includes requirements and recommendations.

About the ISR

Driven by a profusion of government and industry regulations, enterprises are required to record and store an increasing quantity of communications sessions in order to maintain compliance. Conventional call recording solutions, designed for capturing contact center agent exchanges for training or quality assurance purposes, are not well suited to compliance recording applications. They are difficult to integrate with business applications, offer limited scalability, and can be costly to deploy.

The Oracle Communications Interactive Session Recorder (ISR) is specifically designed to eliminate enterprise compliance recording cost and complexity. The solution features an open, standards-based architecture that dramatically simplifies the capture and storage of real-time IP communications sessions throughout the enterprise. Ideal for a wide range of compliance applications, ISR leverages a modular design for superior scalability and economics, offers an extensive API set for ultimate extensibility and flexibility, and includes integrated support for screen recording using an industry leading user monitoring solution.

The ISR leverages SIPREC and a modular architecture for ease of deployment and scale. SIPREC uses a client/server architecture, where the SIPREC client (the Oracle Enterprise Session Border Controller in the image below) initiates SIPREC sessions with the SIPREC server (the Oracle ISR).

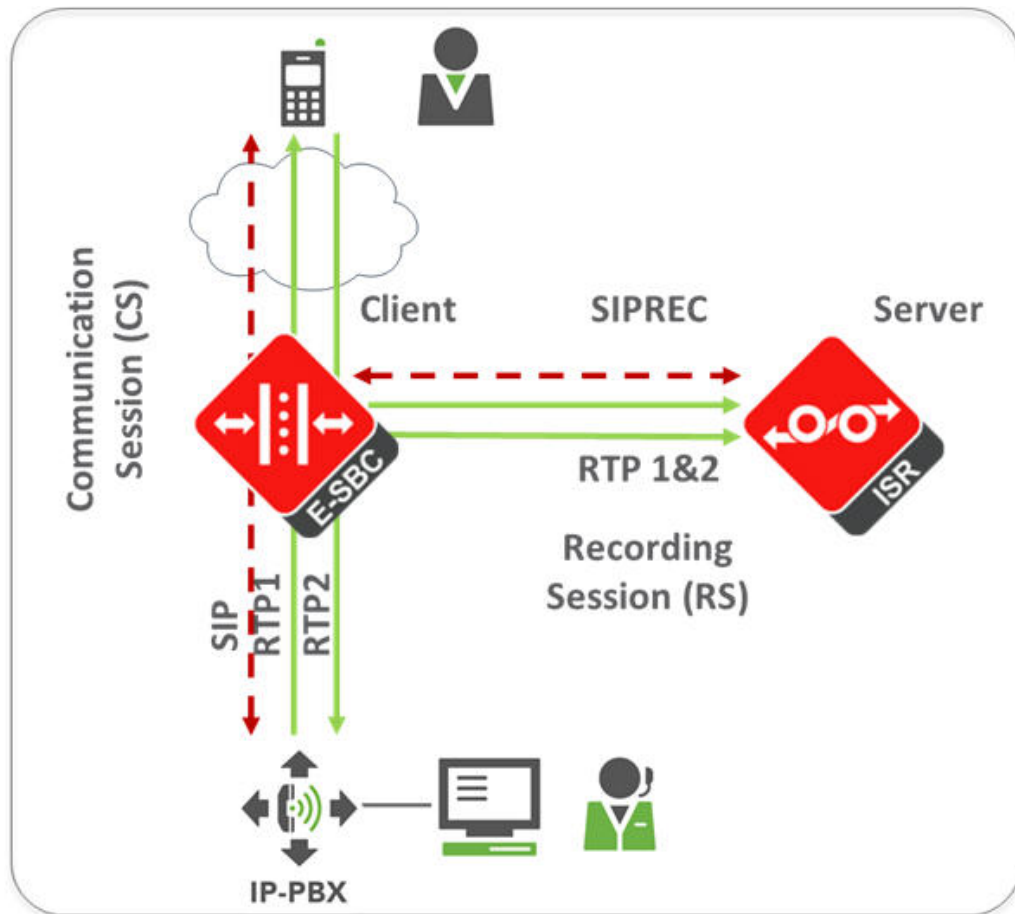

For an introduction to SIPREC and its configuration on the Oracle Session Border Controller, see the "Selective Call Recording/SIPREC" appendix in this guide or .

Session Recording Client Support

The ISR has been tested with the following SIPREC Session Recording Platforms:

- Oracle communications Session Border Controller
- Oracle Enterprise Session Border Controller
- Broadworks Application Server R21

Selective Call Recording SIPREC

The SIPREC protocol is used to interact between a Session Recording Client (SRC) (the role performed by the ISR) and a Session Recording Server (SRS) (a third-party call recorder or Oracle Communications Interactive Session Recorder's Record and Store Server (RSS)). Selective Call Recording controls the recording of media transmitted in the context of a communications session (CS) between multiple user agents.

SIPREC provides a selective-based call recording solution that increases media and signaling performance on a recording server, more robust switchovers, and the ability to selectively record. SIPREC also isolates the RSS from the communication session.

The SRC starts a recording session for every call within a configured realm. All call filtering, if needed, must be accomplished by the recording server. The recording server performs the filtering and the selection of which sessions it should record.

SIPREC supports sending transcoded and SRTP calls.

SIPREC for Active Recording

SIPREC supports active recording, where the ISR (ISR) acting as the Session Recording Client (SRC), purposefully streams media to the Oracle Communications Interactive Session Recorder's RSS (or 3rd party call recorder) acting as the SRS. The SRC and SRS act as SIP User Agents (UA). The SRC provides additional information to the SRS to describe the communication sessions, participants and media streams for the recording session to facilitate archival and retrieval of the recorded information.

The ISR acting as the SRC, is the source for the recorded media. The ISR consumes configuration information describing the ecosystem within which it operates. The interface, realm and session agent configuration objects specify the SIPREC configuration. A SIP UA can elect to allow or disallow any network element from recording its media.

During the establishment of a SIP Session, the ISR determines if SIPREC is configured for recording the call. If so, it then duplicates the media prior to initiating the session with the SRS. (Media replication is set up prior to the recording session). The SRS may choose to record, not record, or cancel the recording session, and then communicates by way of SIP signaling to the ISR. If the call is not to be recorded, the SRS signals termination of the recording session.

The ISR maintains SIPREC metadata information associated with recording sessions. The recording session metadata describes the current state of the recording session and its communication session(s). It is updated when a change of state in the communication session(s) is observed by the ISR. The SRS is responsible for maintaining call history, etc. The ISR creates and logs call detail records (CDRs) in the current manner, the 3rd party SRS vendor may collate this information if desired.

The following illustration shows two endpoints, User Agent A (UA-A) and User Agent B (UA-B). Their session is being recorded by an SRC (the ISR) and an SRS.

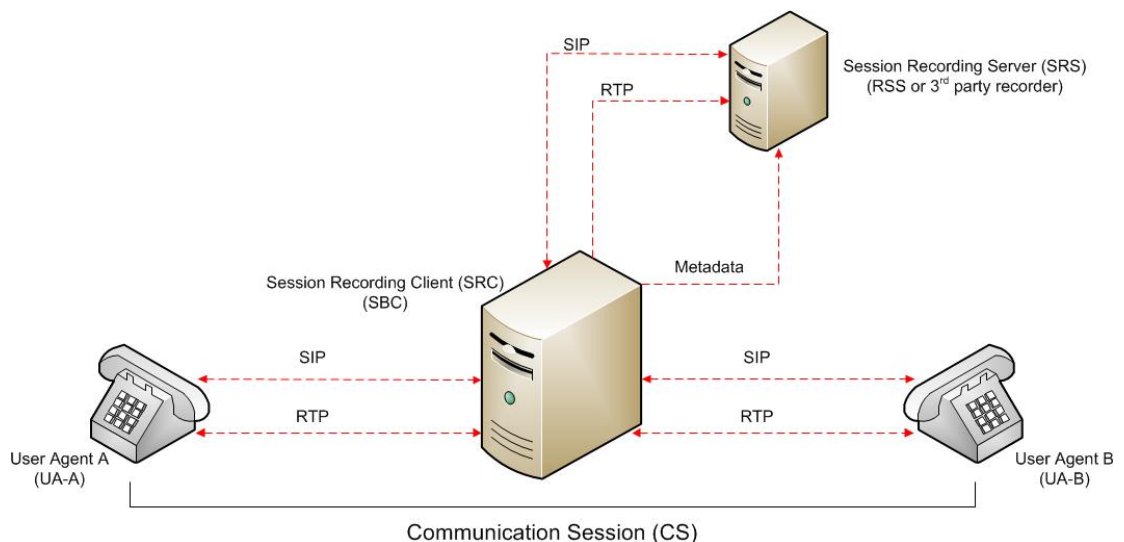

Preserve SIPREC with SIP REFER Header

When the ISR (ISR) generates a new INVITE as part of terminating a SIP REFER, the ISR evaluates the SIPREC configuration of the realms and session agents involved in the new call leg and responds accordingly. The REFER and Transfer mechanism automatically preserves the UCID, XUCID, GUID, GUCID, and UUI in the metadata, and can forward this information to the Session Recording Server. The ISR can Start, Stop, Pause, and Resume SIPREC sessions in response to any re-INVITE, UPDATE, new INVITE, REFER, or specified SIP Response Message.

The ISR can establish a new session or update the existing session with the SIPREC server in the following ways.

- When the A-B call leg SA-realm-sipinterface is configured for SIPREC, and the B-C call leg SA-realm-sipinterface is not configured for SIPREC, the ISR sends metadata to the Session Recording Server to stop the recording on the sessionID associated with the original call.
- When both the A-B call leg and the B-C call leg have the same SIPREC configuration on their SA-realm-sipinterface, the ISR sends metadata to the Session Recording Server to stop Party A participation and start Party C participation within the same sessionID.
- When the A-B and B-C call legs have a different SIPREC configurations on their SA-realm-sipinterface, the ISR sends metadata to the A-B call leg Session Recording Server to stop the current recording session and sends metadata to the B-C call leg Session Recording Server to start a new recording session with a new sessionID.

Configuring SIPREC

For more information on configuring SIPREC on an SBC, see the *Oracle Communications Session Border Controller Call Monitoring Guide*.

ISR FACE

The ISR supports FACE. FACE is a feature for the aggregation and control of events. It is a centralized component used to control both ISR and integrated third-party services. It can also retrieve audio, video, and detailed metadata for recordings stored in the ISR. The initial third-party integration is with the ObserveIT Visual Session Recording solution. This provides the key activities necessary for desktop screen capture and for associating the captured screens to related audio recordings.

The controls currently available include full recording control (start, stop, split, pause, and resume, where split stops recording the current segment and starts recording a new segment, and where pause and resume can aid in the omission of sensitive information from the recording), retrieval of recorded files and metadata, as well as starting and stopping screen capture on an ObserveIT agent host. FACE also supports a policy system allowing incoming events to trigger actions, with the current set of actions dedicated to screen capture control.

The ISR FACE contains the following components:

- FACE Policy System—Handles automatic actions for specific ISR events.

- External Event Notification Listener—Receives events from ISR components and passes them to Policy System.
- FACE REST API—API for communication and control of ISR components.

For more information on ISR FACE, see the *API Reference Guide*.

About the ISR Dashboard

The ISR Dashboard allows you to access, configure, manage, and monitor the ISR in your network, including:

- **Recordings**
- **Reports**
- **Settings**
- **Admin**
 - Accounts
 - Users
 - Realms
 - Routes
 - Authorization Services
 - Custom Data Fields
 - External Event Destinations
 - Recording Format Profiles
 - Security Settings
 - Template Definitions
 - Third Party Services
 - Live Sessions
 - Sites

Requirements

Recommendations

To use the ISR Administrator Dashboard, the following must be met.

Browser Requirements

The ISR Dashboard has been tested on the following browsers:

- Google Chrome™ 60.0.3112.113
- Firefox 52.3.0
- Microsoft Edge 11.0.9600.18762CO

ISR recording playback errors have been reported for the following web browsers:

- Firefox—For the (historically) most popular transmission codec, g711, Firefox is not supporting playback of the 8-bit/8 kHz audio format set in the **"Default" Recording**

Format Profile. The playback controls may appear only briefly before becoming unavailable. To address this issue, changes any routes configured to use the **"Default" Recording Format Profile** to the **"Firefox Supported" Recording Format Profile**, where the g711 transmission codec is converted to the PCM 16-bit/16 kHz recording format.

Security Features

The following security features have been implemented in the ISR:

- Optional configuration to force cookies through an encrypted (SSL/TLS) session. For a procedure to enable serving pages with SSL, see Appendix C, Enable Serving Pages with SSL.
- Cache-control set to 'no-cache' to avoid possible storage of sensitive data in local browser
- Enforced stronger password controls
- Ability to configure password expiration, user lockout duration, and maximum failed login attempts.
- Removed "hidden" URLs

2

Getting Started

This chapter provides information about logging into the ISR Dashboard, editing the Dashboard settings, and using the Dashboard tools while navigating the Dashboard. Dashboard tools include search tools, a download tool, and an import tool for managing information in the ISR database. It is recommended that you review this section before using the ISR Dashboard.

Logging In/Out of the ISR Dashboard

Prior to logging into the ISR Dashboard for the first time, you must enter a valid email and password. However, if your email and password are not available, you may use the following default email and password, then change the email address and password after logging in.

Email: isradmin@acmepacket.com

Password: admin123



Note:

When you login to the ISR Dashboard, depending on your assigned access level, you have access to only your associated ISR Dashboard information. Performance restrictions depend on your login level status. For more information about user login levels, see *User Access Levels and Managing Users*.



Note:

At the time a user is created, the ISR saves their email address and no one else can create a user with the same email address, regardless of whether it is uppercase or lowercase.

To login to the ISR Dashboard:

- Password must be at least 8 characters long.
- Password must contain at least one number (0-9) and one letter (A-Z and/or a-z).
- Password must contain at least one letter and one special character (for example, @, #, \$).



Note:

Your password must meet the following requirements:

1. Open your Internet Web browser (see compatible browser requirements in the Requirements/Recommendations section.).
2. Enter the following URL in the URL field:

`http://<host name or IP>/`

 **Note:**

The host name or IP address you enter here is the name or address assigned to the dashboard VM during installation. The Login page displays.

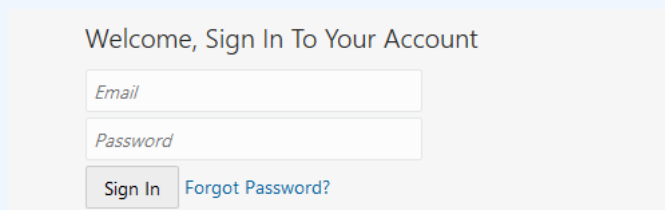

Welcome, Sign In To Your Account

Email

Password

Sign In [Forgot Password?](#)

3. **Email**—Enter your email (username).
4. **Password**—Enter the password provided by your Administrator at the time of the ISR installation. If this is the first time you are logging in, enter the following and press **Enter**.

Email: `isradmin@acmepacket.com`
Password: `admin123`

On first-time login with default user and password, the system prompts you to reset the email address and password. For security purposes, you should change your password every 45 days.



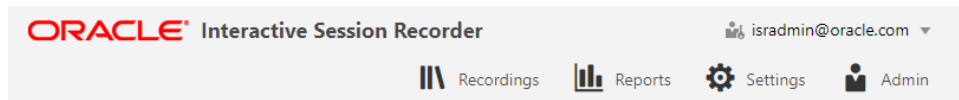

 **Note:**

The number of failed attempts before a user is locked out of the ISR can be configured under the **Admin, Manage Security Settings** link. For more information, see *Chapter 6, Managing Users*. A message displays with the length of time the User has to wait before attempting to log in again. Contact your Administrator if you forgot your password.

After changing your password, the ISR Dashboard Home page (default) displays.



What do you want to do

-  Find Recordings
-  Build Report
-  Edit My Settings
-  Edit System Configurations

The home page provides all of the options available to a user based on their user type. This page allows you to perform the following:

Link	Description
Find Recordings (Recordings in the main menu)	Allows you to view, play, delete and search recordings currently in the ISR database. Also allows you to download the recording metadata to a comma-separated value (CSV) file. For added convenience, after completing a recording search, you can save the search by assigning it a name. You can also create categories and add recordings to the category as applicable. For more information about Recordings, see "Manage Recordings".
<div style="border: 1px solid #0070C0; padding: 10px; background-color: #E6F2FF;"> <p> Note:</p> <p>Displayed recordings are dependent on the level of logged in user. For more information about user levels, see User Access Levels.</p> </div>	
Build Report (Reports in the main menu)	Allows you to generate Usage and Billing reports for routes configured on the ISR. These reports display the information in a Bar Graph as well as in a Data Graph. Note: For more information about Reports, see Manage Reports.
Edit My Settings (Settings in the main menu)	Allows you to view and edit the ISR Dashboard settings such as: <ul style="list-style-type: none"> • Preferred Time Zone Locale • List refresh rate (seconds) • Displayed number of recording entries per page • Specify the fields (columns) to display in a Recording search • Change your user login password For more information about Dashboard settings, see Editing My Settings.

Link	Description
Edit System Configurations (Admin in the main menu)	<p>Allows you to perform the following Administrator tasks, including:</p> <ul style="list-style-type: none"> • Accounts • Realms • Routes • Users • Authorization Services • Custom Data Fields • External Event Destinations • Locales • Recording Format Profiles • Security Settings • Template Definitions • Thirdparty Services • Live Sessions • Sites (includes Recorders, Locations, Archival) <p>Note: Display of this feature is dependent on the level of logged in user. For more information about user levels, see User Access Levels.</p> <p>For more information about Administrator features, see Managing Realms/Accounts, Managing Routes, Managing Users, Managing Sites, Managing Authorization Services, and Viewing Live Sessions.</p>

 **Note:**
The Admin link displays for Super Users, Account Administrators, and Tenant Administrators only.

To logout of the ISR Dashboard:

Click the username in the upper-right corner of the page and select **Logout** from the drop-down list.. The ISR Dashboard immediately logs you out.

User Access Levels

All users can access the ISR Dashboard. However, the functions available to the logged in user are dependent on the level of access assigned. The following table identifies the functions available at each user level.

 **Note:**
The Edit System Configuration (Admin) menu in the ISR Dashboard displays **ONLY** for users logged in as Super User.

User Type	Find Recordings (Recordings)	Build Reports (Reports)	Edit My Settings (Settings)	Edit System Configurations (Admin)
Super User	Yes	Yes	Yes	Yes (Can manage all)

User Type	Find Recordings (Recordings)	Build Reports (Reports)	Edit My Settings (Settings)	Edit System Configurations (Admin)
Account Administrator	View only.	Yes	Yes	Yes (Can manage all EXCEPT Super User and sites)
Tenant Administrator	View and delete own recordings only. (Permissions to edit must be assigned.)	Yes (Reports include info from own accounts only)	Yes	Yes (Can manage own Accounts, Routes, Tenant Admin, Tenant User only)
Tenant User	View and delete own recordings only. (Permissions to edit must be assigned.)	Yes (Reports include info from own accounts only)	Yes	No
API User	N/A	N/A	N/A	N/A

API users are currently specific to the ISR FACE REST API only and cannot log into the ISR Dashboard.

For more information about user login levels, see *Chapter 6, Managing Users*.

Help Link

Online support is available for the ISR Dashboard by clicking on the Help link (the question mark symbol '?') in the upper right corner of any page in the Dashboard.

The Help window has two tabs, Support, which provides the Oracle Support Portal's website, as well as all of the information to include in a service request. The About tab provides the ISR software version and build numbers you are running.

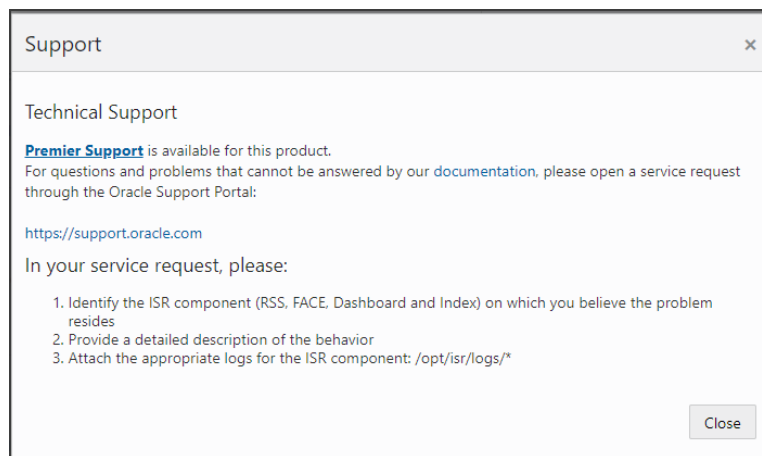

 **Note:**

Help Text is customizable for each account. For more information on Dashboard branding, see Account Branding in Chapter 3.

Dashboard Settings

The **Dashboard Settings** page (**Settings** in the Main Menu) in the ISR allow you to customize specific elements of the Dashboard for your environment. These settings apply to the current logged in user only. You can configure:

- Dashboard Settings
- Recordings List Settings
- RSS View Settings
- Change Password

To configure the Dashboard settings:

1. After logging into the ISR Dashboard, click **Edit My Settings** (**Settings** in the Main Menu). The following Dashboard Settings page displays.

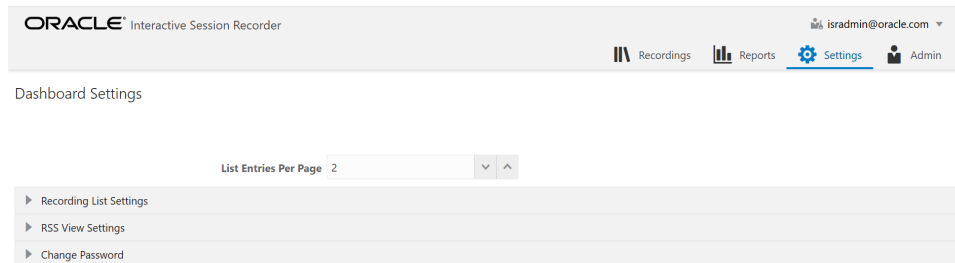

2. **Preferred Language**—Select the language you prefer.
3. **Preferred Time Zone Locale**—Select the time zone locale associated with your location or location of the user. The following table provides the valid values for this field.

Abu Dhabi	Copenhagen	London	Sapporo
Adelaide	Darwin	Madrid	Sarajevo
Alaska	Dhaka	Magadan	Saskatchewan
Almaty	Dublin	Marshall Is.	Seoul
American Samoa	Eastern Time (US & Canada)	Mazatlan	Singapore
Amsterdam	Edinburgh	Melbourne	Skopje
Arizona	Ekaterinburg	Mexico City	Sofia
Astana	Fiji	Mid-Atlantic	Solomon Is.
Athens	Georgetown	Midway Island	Srednekolymsk
Atlantic Time (Canada)	Greenland	Minsk	Sri Jayawardenepura
Auckland	Guadalajara	Monrovia	St. Petersburg

Azores	Guan Hanoi	Monterrey	Stockholm
Baghdad	Harare	Montevideo	Sydney
Baku	Hawaii	Moscow	Taipei
Bangkok	Helsinki	Mountain Time (US & Canada)	Tallinn
Beijing	Hobart	Mumbai	Tashkent
Belgrade	Hong Kong	Muscat	Tbilisi
Berlin	Indiana (East)	Nairobi	Tehran
Bern	International Date Line West	New Caledonia	Tijuana
Bogota	Irkutsk	New Delhi	Tokelau Is.
Brasilia	Islamabad	Newfoundland	Tokyo
Bratislava	Istanbul	Novosibirsk	UTC
Brisbane	Jakarta	Nuku'alofa	Ulaanbaatar
Brussels	Jerusalem	Osaka	Urumqi
Bucharest	Kabul	Pacific Time (US & Canada)	Vienna
Budapest	Kaliningrad	Paris	Vilnius
Buenos Aires	Kamchatka	Perth	Vladivosotok
Cairo	Karachi	Port Moresby	Volgograd
Canberra	Kathmandu	Prague	Warsaw
Cape Verde Is.	Kolkata	Pretoria	Wellington
Caracas	Krasnoyarsk	Quito	West Central Africa
Casablanca	Kuala Lumpur	Rangoon	Yakutsk
Central America	Kuwait	Riga	Yerevan
Central Time (US & Canada)	Kyiv	Rihadh	Zagreb
Chatham Is.	La Paz	Rome	Zurich
Chennai	Lima	Samara	N/A
Chihuahua	Lisbon	Samoa	N/A
Chongqing	Ljubljana	Santiago	N/A

4. **Preferred Time Format**—Select the time format for the Dashboard to follow. Valid values are:
 - 12 (default)
 - 24
5. **List Refresh Rate Seconds**—Select the number of seconds that the dashboard waits before refreshing the recordings list. Valid values are:
 - None (default)
 - 30 seconds
 - 1 minute
 - 2 minutes
 - 5 minutes
6. **List Display Entries Per Page**—Enter the number of entries per page to display on the Recordings page. For example, entering a value of 7 in this field displays 7 recording entries per page in the Recordings List. Valid values are 1 to 100. Default is 20.
7. Click **Update**.

Recordings List Settings

Using the Recordings List Settings, you can customize the columns that display on the Recordings List page.

To configure the Recordings List settings:

1. After logging into the ISR Dashboard, click **Edit My Settings** in the main menu (or **Edit System Configurations** on the Home page).
2. Click **Recording List Settings**.

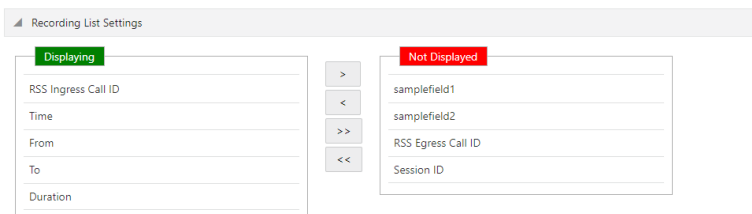

3. Add headings to the display list by clicking a heading from the **Not Displayed** column and dragging it to the **Displaying** column. The red box you placed in the Displaying column turns green.

Remove headings from the display list by clicking a heading from the **Displaying** column and dragging it to the **Not Displayed** column. The green box you placed in the Not Displayed column turns red.

You can place a maximum of 5 headings in the Displaying column.

The following table describes the headings you can select to display in the Recordings list.

Heading	Description
Time (default)	Displays the date and time the recording started. This column is based on the user's GMT offset and is in the format MM/DD/YY HH:MM:SS (AM or PM).
From (default)	The number that the caller dialed from (i.e., Caller ID).
To (default)	Displays the number that the caller dialed.
Duration (default)	Displays the length of the recording (in seconds)
Session ID	Displays the Session ID derived from the X-ISR-UCID.
RSS Egress Call ID	Displays the unique egress call ID derived from the call-id used in the egress call leg for the recording (only used in pass-thru mode).
RSS Ingress Call ID (default)	Displays the unique ingress call ID derived from the call-id received in the initial SIP INVITE.
Custom Data Fields	Displays a Custom Data field name as a Recordings list heading, and a valid Custom Data field value displays in that column for each recording.

4. Click **Update** to save the recordings list settings.

The headings listed in the Displaying column (green boxes) display as column headings on the Recordings List page.

RSS View Settings

Using the RSS View Settings, you can set the maximum entries to include from the RSS error logs.

To configure the RSS view settings:

1. After navigating to the Dashboard Settings page, click **RSS View Settings**.
2. **Max Error Log Entries**—Enter the number of entries to show on each RSS error log page. Valid values are 1-255. Default is 20.
3. Click **Save** to save the RSS view settings.

Change Password

Use the Change Password tab to change your current ISR login password to a new password.

To change your password:

1. After navigating to the Dashboard Settings page, click **Change Password**.
2. **Current Password**—Enter the current password you use to log into the Dashboard.
3. **Password**—Enter your new password for logging into the Dashboard. Your password must meet the following requirements:
 - Password must be at least 8 characters long.
 - Password must contain at least one number (0-9) and one letter (A-Z and/or a-z).
 - Password must contain at least one letter and one special character (for example, @, ##, \$).
4. **Confirm Password**—Reenter your new password to confirm the new Dashboard password.
5. Click **Update** to save your new password.

 **Note:**

Default security settings require a new password not be the same as one used in the previous four attempts. If you attempt to enter a new password that was previously used, an error message appears.

Dashboard Tools

The ISR Dashboard provides various tools that allow you to perform specific functions on each page.

- Paging Tool
- Search Tools
- Column Sorting Tool
- Download Tool

- Import Link

Paging Tool

The ISR Dashboard provides a paging tool to help you navigate through pages if the data that displays is greater than the number set for the **Settings, List Display Entries per Page** parameter.

Note:

This paging tool displays **ONLY** if the elements in the list require more than one page for display. For more information about setting the display entries per page, see [Editing My Settings](#).

You can click on "**Next**" to move to the next page, or Previous to move to the previous page. If more than one page exists, the number for each page displays with the navigation tools. You can click on any page number to display the data on that page.

Search Tools

The ISR Dashboard provides a search tool you can use to search for specific information in the ISR database. The search feature is applicable to:

- Recordings
- Routes

Basic Search for Recordings

You can perform a basic search for a specific recording. A basic search uses an exact match on a single common search field and does not support wildcard matching.

To perform a basic search for a recording:

1. Click **Recordings** in the main menu. A list of recordings stored in the ISR database display.

Recordings

Quick Search From Search Advanced Search Refresh

Delete Details

RSS Ingress Call ID	Start Time	From	To	Duration
00E1C987-8787-E911-9030-2F98017E1DCD@10.191.45.119	2019-06-07 05:51:08 AM	SIPPER	R5522	10 seconds
1-1751@10.178.248.32	2019-06-07 05:50:38 AM	7777	5555	10 seconds
1-1749@10.178.248.32	2019-06-07 05:50:22 AM	7777	5555	10 seconds
00F82452-8787-E911-902F-2F98017E1DCD@10.191.45.119	2019-06-07 05:49:38 AM	SIPPER	R5522	11 seconds

0-4 of 4 items

Download as CSV file
Include Details

2. In the drop-down box (at the top-right of the Recordings page), select the information about the recording(s) that you want to search. Valid values are:
 - From - ID of the caller for this call.
 - To - ID of the recipient for the call.

- Session ID - Session ID derived from the X-ISR-UCID
 - Label - In the case where **Label** is mentioned in the route, it is displayed in place of the **From** and **To** values. This depends on the Route Type.
3. In the text box, enter the information required dependent on the selection you made in Step 2.

For example, if you selected From in the drop-down box, enter the ID of the caller associated with a recording for which you want to search. All the recordings associated with that caller ID display in a list.

 **Note:**

You can select a recording and click on **Details** to reference the "Session ID", "From", and "To" information for the recording if required.

4. Click **Search** to find all recordings based on the search criteria. All matching recordings display in the recordings list.
5. Once matching Recordings are displayed, you can play individual recordings by clicking **Details**.
6. Click the Previous button to go back to the original search page.
7. Click the **Refresh** button to load all Recordings.

Advanced Search for Recordings

You can perform more advanced searches for recordings. Advanced searches allow more search options, including multiple search fields and partial matching.

To perform an advanced search for a recording:

1. On the Recordings page, click **Advanced Search**.

The following dialog box displays.

Advanced Search

Select Mode: And

Partial Match: No

Session ID: [Text Input]

From: [Text Input]

To: [Text Input]

Label: [Text Input]

Search Date: By Relative By Range

Today

▶ More Recording Search Options

▶ By Segment Search Options

▶ By Session Search Options

Search

2. **Select Mode**—Select whether to perform the search using **AND** or **OR**.
 - **AND**—Returns results where recordings match ALL fields you specify. For example, if you specify From as "123", File Name as "Recording1", and "Search Date as "Today", then the results of the search show all recordings with a start date matching the current date, AND a value of "123" in the From field, AND file name of "Recording1".
 - **OR**—Returns results where recordings match ANY of the fields you specify. For example, if you specify From as "123", File Name as "Recording1", and Search Date as "Last 7 Days", then the results of the search show any recordings with a value of "123" in the From field, OR a file name of "Recording1", a start date within the last seven days (OR a a result that includes all of these).
3. **Partial Match**—When enabled, the ISR finds recordings that partially match the values entered in the search fields.
4. **Session ID**—The unique Session ID derived from the X-ISR-UCID on which to perform the search.
5. **From**—The From SIP URI to perform the search on.
6. **To**—The To SIP URI to perform the search on.
7. **Label**—The route label to perform a search on.
8. **Search Date**—Select whether you want to search for recordings **By Relative** or **By Range**:
 - By Relative**—Allows you to perform a search for recordings that happened "Today" (default), within the **Last 7 Days**, or within the **Last 30 Days**.
 - By Range**—Allows you to perform a recording search, based on the date range you specify.

 **Note:**

Search Date is always included in the advanced search terms. Therefore, when using Search Mode "OR" with a large date range, many recordings may be returned.

- If you select a **Search Date By Range**, enter the **From Date** and **To Date** in the format MM/DD/YYYY, or click on the calendar icon next to the text box to select the dates for which you want to search for recordings. In the **From Date** and **To Date** boxes, select the time in the format HH:MM for which you want to search for recordings. The time displayed shows the time zone set by the logged in user. By default, the **From Date** is always behind the **To Date** time by 4 hours.

In the "**From Date** and **To Date** boxes, select the time in the format HH:MM for which you want to search for recordings.

 **Note:**

For convenience, clicking in the text box displays a pop-up calendar for which you can select the month, day, and year.

- Click **Search** to find all recordings based on the search criteria. All matching recordings display in the recordings list.
- Once matching Recordings are displayed, you can play individual recordings by clicking **Details**.
- Click the **Previous** button to go back to the original search page.
- Click the **Refresh** button to load all Recordings.

More Recording Search Options

You can perform recording searches based on additional search criteria as follows.

To perform a more advanced search for recordings:

- In the Advanced Search dialog box, click **More Recording Search Options** to expand the dialog box.

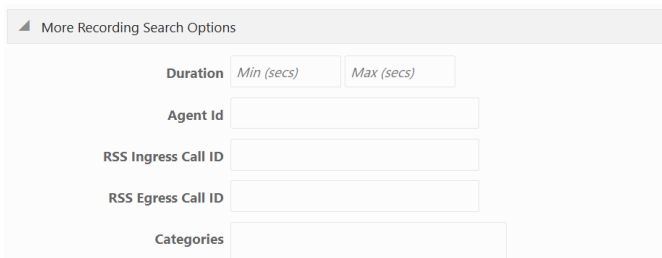

More Recording Search Options

Duration

Agent Id

RSS Ingress Call ID

RSS Egress Call ID

Categories

- Duration Min**—The minimum duration, in seconds, of a recording. Valid values are numeric characters. For example, 15.
- Duration Max**—The maximum duration, in seconds, of a recording. Valid values are numeric characters. For example 24.

Using the examples in Steps 3 and 4, the results would include all recordings that had a recording duration between and including 15 and 24 seconds.

4. **Agent ID**—The ID of the agent that answered the call. This is the value set in the Dashboard or API.
5. **RSS Ingress Call ID**—The ingress call ID derived from the call-id received in the initial SIP INVITE.
6. **RSS Egress Call ID**—The egress call ID derived from the call-id used in the egress call leg for the recording, if using pass-thru mode.
7. **Categories**—The name of the category for which you want to search for recordings. The category you enter in this field must already exist in the database. For more information about creating and searching categories, see Recording Details.
8. Click **Search** to find all recordings based on the search criteria. All matching recordings display in the recordings list.

Recording Search by Segment

You can search for recordings by segment.

To search for recordings based on segment:

1. In the Advanced Search dialog box, click **By Segment Search Options** to expand the dialog box.
2. **Media Type**—Select the recorded file type, either Audio or Video.
3. **File Name**—Enter the segment file name, for example, 1-9599@10.1.2.3.4.seg0.wav.

Recording Search by Custom Data

You can search for recordings by custom data values.

To search for recordings based on custom data values:

1. In the Advanced Search dialog box, click **By Custom Data Search Options** to expand the dialog box.



▲ By Custom Data Search Options

samplefield1

samplefield2

2. The currently configured Custom Data Field names are listed. Enter the value(s) for which you want to search next to the corresponding Custom Data Field name(s).
3. Click **Search** to find all recordings based on the specified custom data. All matching recordings display in the recordings list.

Note:

Custom Data search parameters are applied in addition to any other search options defined, including date ranges.

Recording Search by Session

You can search for recordings by session criteria if required.

To search for recordings based on session criteria:

1. In the Advanced Search dialog box, click **By Session Search Options** to expand the dialog box.

By Session Search Options

SIPREC Session ID

Participant AOR

apkt:ucid

extTrackingID

serviceProviderID

userID

groupID

callID

callingPartyNumber

calledPartyNumber

newExtTrackingID

apkt:realm

apkt:P-Asserted-Identity

apkt:Diversion

apkt:request-uri

callData:fromhdr

callData:tohdr

callData:callid

callData:gcid

2. **SIPREC Session ID**—The SIP recording session ID number for which you want to search.

 **Note:**

You can select a recording and click on the Details icon to reference the SIPREC Session ID information for the recording if required.

3. **Participant AOR**—The participant's address of record (AOR) associated with the call that was recorded.
4. **apkt:ucid**—The Universal Call ID (UCID) of the incoming caller.
5. **extTrackingID**—The external tracking ID that was used when an incoming call was transferred to another recipient.
6. **ServiceProviderID**—The Service Provider ID that was used on the incoming call.
7. **userID**—The user ID on the incoming call.
8. **groupID**—The group ID on the incoming call.
9. **callID**—The call ID of the incoming call.

10. **callingPartyNumber**—The source number of the incoming call.
11. **calledPartyNumber**—The destination number of the incoming call.
12. **newExtTrackingID**—The new external tracking ID that was used when an incoming call was transferred a second time to another recipient.

 **Note:**

The extTrackingID, ServiceProviderID, userID, groupID, callID, callingPartyNumber, calledPartyNumber, and newExtTrackingID parameters are specific to a SIPREC integration with Broadsoft's Broadworks platform and may not be shown in all installations.

13. **apkt:in-realm**—The name of the ISR realm that received the SIPREC session (in-realm).
14. **apkt:P-Asserted-Identity**—The remote party's ID in the SIPREC session. The ISR uses the P-Asserted-Identity header field to convey the proven identity of the originator of a request within a trusted network.
15. **apkt:Diversion**—The call forwarding phone number from the SIPREC session, to which the incoming call was diverted. Diversion is a call forwarding feature that lets an incoming call to a called party be redirected to a third party.
16. **apkt:request-uri**—The Uniform Resource Identifier (URI) in the header of the request message of the SIPREC session. The URI in the request message contains sufficient information to initiate and maintain the SIPREC communication session.
17. Click **Search** to perform the search based on the recording session parameters you specified. All matching recordings display in the recordings list.

 **Note:**

Session search parameters are applied in addition to any other search options defined, including date ranges.

Basic Search for Routes

You can perform a basic search for Routes configured in the ISR database based on the route pattern.

To perform a basic search for a route:

1. Click **Admin** in the main menu (or **Edit System Configurations** on the Home page).
2. Click **Routes**. A list of routes display in the routes list.

Routes

Account	Type	Pattern	Virtual Pattern	Recording is	Percent To Record
System	To	%	%DNIS%	Enabled	100

3. In the drop-down box (on the upper-left of the page), select the account for which you want to search for a route(s).

Note:

The values in the drop-down box include any accounts you've added to the ISR database.

4. In the text box (on the upper-right of the page), enter the route pattern for which to search. This field does not support partial matches.
5. Click **Search** to perform the search based on the criteria you specified. All matching routes display in the routes list.

Column Sorting Tool

In the ISR Dashboard, you can sort the list of recordings in ascending or descending order by clicking the column heading.

To sort the recording data in the recording list:

- Click any of the column headings to sort that column in ascending or descending order. The Up Arrow icon indicates the column is currently in ascending order. The Down Arrow icon indicates the column is in descending order.

Download Tool

You can download a single specific recording file for playing immediately, or save the recording (.wav file) to a storage location on your PC to listen to later. You can also download the metadata for all recordings in the recording list to a CSV file on your PC.

Downloading a Single Recording File

You can download a single recording file to play immediately, or save the recording to your PC to play later.

To download a single recording file:

1. Click **Recordings**. The recordings list displays.
2. Select a recording by clicking on the row and clicking the **Details** button to bring up the Recording Details page. Click the segment(s) (for example, the Segment 1 tab) and click **Download**.

The ISR stores the file in a temporary folder on your computer.

3. Click **Open with** and select the application for which to play the .wav recording file or click **Save File** to save the .wav recording file to a location on your PC for listening to later.

 **Note:**

If you click the Download icon more than once for the same recording, additional copies of the same file are saved, appending a numerical digit to the file name. For example:

rss_g711-24-1841@172.30.58.237 (1).wav,

rss_g711-24-1841@172.30.58.237 (2).wav,

rss_g711-24-1841@172.30.58.237 (3).wav, etc.

 **Note:**

The names of these options may vary between browsers.

4. Click **OK**. Your browser immediately opens and plays the .wav file, or downloads it to your PC for listening later.

Downloading a Recording List to a CSV File

You can download Recordings to .CSV file (<filename>.csv) per page (List Entries Per Page) basis and then open the file for viewing using an application that recognizes the CSV format (for example, Notepad® or Microsoft® Excel). The resulting file contains the details of each recording (not the actual recorded files).

 **Note:**

Default List Entries per Page is 10 and only 10 Recordings are downloaded to the .CSV file.

To download a recording list's metadata to a CSV file:

1. On the Recordings page, click **Download as CSV file** to download the current list of recordings to a CSV file.
2. **Include Details**—Place a checkmark in the check box to include all details about the recording in the CSV file.

 **Note:**

If you click Download as CSV file without checking the Include Details box, the ISR Dashboard only downloads the information in the columns that currently display in the recordings list. If you place a checkmark in the Include Details box, the ISR Dashboard includes all column attribute information, including those columns, not listed in the current recording list. Custom data fields will appear as one column with key and value pair in the form of array (for example, [{"recordcount"=>"23"}, {"Custom"=>"custom1"}]).

The ISR automatically provides a filename of recordingResults.csv and stores the file in a temporary folder on your computer.

3. Click **Open with** and select the application for which to open the resulting CSV file.
or
Click **Save File** to save the CSV file to your PC.

 **Note:**

If you choose Save File, and you click Download as CSV file more than once, each time the ISR generates a CSV file, it appends a numerical digit to the file name. For example:

recordingResults (1).csv

recordingResults (2).csv

recordingResults (3).csv

 **Note:**

The names of these options may vary between browsers.

4. Click **OK**. The CSV file is opened with the application you specified, or is saved to your PC for viewing later.

Example CSV file with recordings and no detail specified

	A	B	C	D	E
1	RSS Ingress Call ID	Time	From	To	Duration
2	24-1841@172.30.58.237	11/17/2016 12:27	sipp_g711	rss_g711	10
3	23-1841@172.30.58.237	11/17/2016 12:27	sipp_g711	rss_g711	10
4	22-1841@172.30.58.237	11/17/2016 12:27	sipp_g711	rss_g711	10
5	21-1841@172.30.58.237	11/17/2016 12:26	sipp_g711	rss_g711	10
6	20-1841@172.30.58.237	11/17/2016 12:26	sipp_g711	rss_g711	10
7	19-1841@172.30.58.237	11/17/2016 12:26	sipp_g711	rss_g711	10
8	18-1841@172.30.58.237	11/17/2016 12:26	sipp_g711	rss_g711	10
9	17-1841@172.30.58.237	11/17/2016 12:26	sipp_g711	rss_g711	10
10	16-1841@172.30.58.237	11/17/2016 12:26	sipp_g711	rss_g711	10
11	15-1841@172.30.58.237	11/17/2016 12:25	sipp_g711	rss_g711	10
12	14-1841@172.30.58.237	11/17/2016 12:25	sipp_g711	rss_g711	10
13	13-1841@172.30.58.237	11/17/2016 12:25	sipp_g711	rss_g711	10
14	12-1841@172.30.58.237	11/17/2016 12:25	sipp_g711	rss_g711	10
15	11-1841@172.30.58.237	11/17/2016 12:25	sipp_g711	rss_g711	10

Example CSV file with recordings and detail specified

A	B	C	D	E	F	G	H	I	J	K	L	M	N	O
Transit To	Time	Session ID	Rating	RSS Ingress Call ID	RSS Egress Notes	Hours	From	File Name	Duration	OTM#	Events	Custom Data	Session Extension Data	
1	rsr_g711	11/17/2008 12:27	x-isr-ucid-34-1841@172.30.58.237	0	20-1841@172.30.58.237		0	rsr_g711	10.207		[[{"event_type": "1000", "origin_source": "0", "dmt_dig": [{"examplefield1": "val1"}, {"examplefield2": "val2"}], [{"webuser": "SR_A8800380054912027_moodingher"}]]			
2	rsr_g711	11/17/2008 12:27	x-isr-ucid-23-1841@172.30.58.237	0	20-1841@172.30.58.237		0	rsr_g711	10.207					
3	rsr_g711	11/17/2008 12:27	x-isr-ucid-21-1841@172.30.58.237	0	20-1841@172.30.58.237		0	rsr_g711	10.207					
4	rsr_g711	11/17/2008 12:26	x-isr-ucid-21-1841@172.30.58.237	0	20-1841@172.30.58.237		0	rsr_g711	10.207					
5	rsr_g711	11/17/2008 12:26	x-isr-ucid-20-1841@172.30.58.237	0	20-1841@172.30.58.237		0	rsr_g711	10.207					
6	rsr_g711	11/17/2008 12:26	x-isr-ucid-19-1841@172.30.58.237	0	20-1841@172.30.58.237		0	rsr_g711	10.207					
7	rsr_g711	11/17/2008 12:26	x-isr-ucid-18-1841@172.30.58.237	0	20-1841@172.30.58.237		0	rsr_g711	10.207					
8	rsr_g711	11/17/2008 12:26	x-isr-ucid-17-1841@172.30.58.237	0	20-1841@172.30.58.237		0	rsr_g711	10.207					
9	rsr_g711	11/17/2008 12:26	x-isr-ucid-16-1841@172.30.58.237	0	20-1841@172.30.58.237		0	rsr_g711	10.207					
10	rsr_g711	11/17/2008 12:25	x-isr-ucid-15-1841@172.30.58.237	0	20-1841@172.30.58.237		0	rsr_g711	10.207					
11	rsr_g711	11/17/2008 12:25	x-isr-ucid-14-1841@172.30.58.237	0	20-1841@172.30.58.237		0	rsr_g711	10.207					
12	rsr_g711	11/17/2008 12:25	x-isr-ucid-13-1841@172.30.58.237	0	20-1841@172.30.58.237		0	rsr_g711	10.207					
13	rsr_g711	11/17/2008 12:25	x-isr-ucid-12-1841@172.30.58.237	0	20-1841@172.30.58.237		0	rsr_g711	10.207					
14	rsr_g711	11/17/2008 12:25	x-isr-ucid-11-1841@172.30.58.237	0	20-1841@172.30.58.237		0	rsr_g711	10.207					
15	rsr_g711	11/17/2008 12:25	x-isr-ucid-10-1841@172.30.58.237	0	20-1841@172.30.58.237		0	rsr_g711	10.207					

The following table identifies some of the columns that can display in the CSV file.

Column Heading	Description
To	Specifies the To SIP URI. This is the URI for where the call is going.
Time	Specifies the starting GMT time and date of the recording in the format YYYY-MM-DD HH:MM:SS, respectively. Note: In the date format, M = month, D = day, and Y = year. In the time format, H = hours, M = minutes, S = seconds.
Session ID	Specifies the Session ID assigned to the incoming call. Format may be specified as x-isr-ucid-<session id>@<local host>.
Rating	Specifies the score assigned to a recording by a reviewer and can be assigned as needed by your organization. Scoring is based on 1 to 5 stars.
RSS Ingress Call ID	Specifies the call ID assigned by the RSS to the incoming call.
RSS Egress Call ID	Specifies the call ID assigned by the RSS to the outgoing leg of the call (pass-thru mode only).
Notes	Specific notes, if any, entered by users through the dashboard.
Hours	Specifies the length of time, in hours, a user spent reviewing, transcribing, and commenting on the recording.
From	Specifies the From SIP URI. This is the URI from where the call session was coming.
File Name	Specifies the name of the recording file.
Duration	Specifies the length of the recording (in seconds).
Custom Fields	Specifies a unique set of meta-data associated with the recording (i.e., Transaction ID, Account Number, Unique Call ID). For more information on Custom Fields, see "FACE Custom Data" in the <i>Oracle Communications Interactive Session Recorder API Guide</i> .
Completed	Specifies whether or not this recording resulted in a complete transaction, added by the dashboard user.
Agent ID	Specifies the ID of the Agent answering the call.

Import Link

The ISR allows administrators to specify account and/or route parameters in a comma separated value (CSV) file, save the file, and then import the information into the ISR database using the ISR Dashboard's Import link (located in the top right corner of both the Accounts and Routes pages) . An administrator can use any application that can save to a CSV file (i.e., Microsoft® Excel, Notepad®, etc.) when inputting the account and/or route information into the file.

**Note:**

The import link is for Super User and Account Administrators only.

Administrator Menu

The ISR Dashboard's Admin page displays a menu that allows Administrators to manage ISR configurations, settings, and security, and also provides pie charts with the run status for each configured Site.

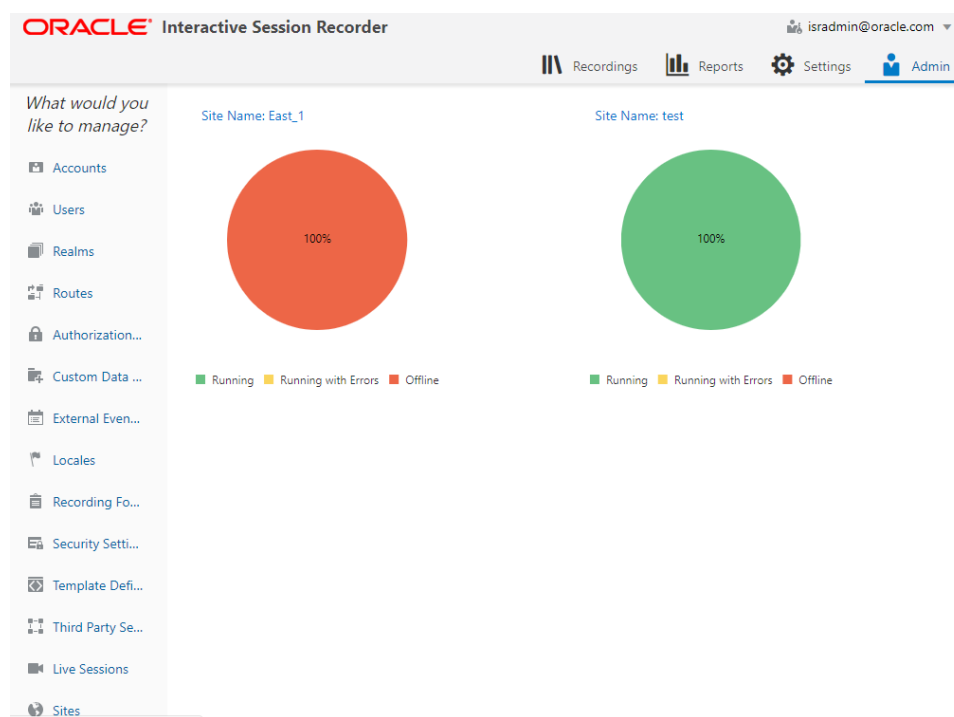

This menu displays for a Super User, Account Administrator, and a Tenant Administrator only. However, the Admin menu is limited for the Account Administrator and the Tenant Administrator.

The following table describes the permissions available for each of the ISR's administrator levels.

Admin Function	Account Administrator	Tenant Administrator
Accounts	Manage Accounts	Manage own Accounts only
Users	Manage Users (Account Admin, Tenant Admin, and Tenant User only)	Manage Users (Tenant Admin and Tenant User only)
Realms	N/A	N/A
Routes	Manage Routes	Manage own Routes only
Authorization Services	Manage Authorization Services	N/A
Custom Data Fields	Manage Custom Data Fields and Names	N/A

Admin Function	Account Administrator	Tenant Administrator
External Event Destinations	Manage External Events and Notifications	N/A
Locales	Manage Locales	N/A
Recording Format Profiles	Manage Recording Format Profiles	N/A
Security Settings	Manage Security Settings	N/A
Template Definitions	Manage Template Definitions	N/A
Third Party Services	Manage Thirdparty Services	N/A
Live Sessions	Manage Live Sessions	N/A
Sites	Manage Sites	N/A

3

Managing Accounts

This chapter introduces the functions available to the Administrator in the ISR Dashboard. It also includes information about adding, editing, and deleting accounts from the ISR database.

Managing Accounts

Use the **Accounts** link on Admin page of the ISR Dashboard to manage accounts in the ISR network.

The Accounts page in the ISR Dashboard allows you to add new Account(s) and configure account parameters. This function also allows you to view, edit, and delete existing Accounts on the ISR.

For each account, you can configure account branding and configure route defaults. You can configure multiple accounts (supports multi-tenancy) if required, and assign specific users or edit user parameters for each account.



Note:

A default System Account exists under the Accounts page and should not be renamed or deleted. This account includes all users and routes configured on the ISR. Users assigned as Super Users and Account Administrators can edit the System Account. For more information about users, see Chapter 6, Managing Users.

You can also use other applications (i.e., Microsoft® Excel, Notepad®) to specify the parameters for an account, and then import the contents of the file into the ISR Dashboard.

Select **Accounts** from the Admin page to manage Accounts.

Accounts Page

Accounts

Account Name	Description	Recorder State	Account Port Limit	Video Recording Enabled	Play Back Recording Permission	Delete Recording Permiss
Acc1	Acc1	1	4	true	1	1
Acc2	Acc2	1	5	true	1	1
System	System	1	-1	true	1	1

The following table describes the information displayed on the Accounts page.

Column	Description
Account Name	Name of the account.
Description	Description of the account.
Number of Routes	Number of routes configured for the account.
Recorder State	Identifies whether or not recording is enabled or disabled on the account.
Sessions Capacity	Total number of available sessions currently allowed for this account.

The following table describes the buttons on the Accounts page.

Button	Description
Create	Create an Account.
Edit	Edit an Account. This button is only enabled when an Account row is selected.
Delete	Delete an Account. This button is only enabled when an Account row is selected.

Adding an Account

You can add an account(s) using the ISR Dashboard. After adding an account, the settings are applied as the default settings for all routes under that account.

Note:

You can create an account using any application that can save to a comma separated value (CSV) file (i.e., Microsoft® Excel, Notepad®, etc.). Using the ISR Dashboard, you can then import the account information from the file (<filename>.csv) to the ISR database. For more information about importing account information into the ISR database, see Importing an Account CSV File.

Only a Super User and Account Administrator can add new accounts.

To add an account:

1. After logging into the ISR Dashboard, click **Admin** in the main menu (or **Edit System Configurations** on the Home page).
2. Click **Accounts**. The Accounts page displays.
3. Click **Create**. The following dialog box displays.

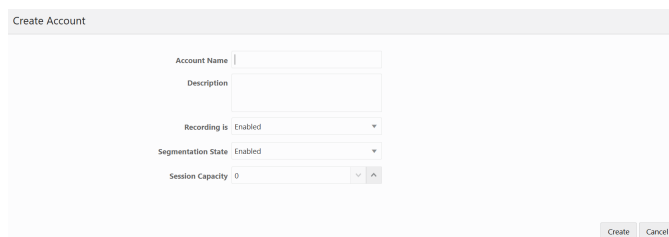

4. **Account Name**—Enter an account name for this account.
5. **Description**—Enter a description for this account.
6. **Recording is**—Select whether or not to enable recordings on this account. Valid values are:
 - Enabled (default)
 - Disabled
7. **Segmentation State**—Select whether or not to enable recording segmentation via FACE API requests or reINVITE.
8. **Sessions Capacity**—Enter the maximum number of call recording sessions simultaneously available for routes to use on this account. When the maximum session capacity is reached across all routes on the account, a recording may indicate to the caller that all lines are busy and to call back at another time. Valid values are:
 - 1 to 999999999 (must indicate total number of licensed sessions)
 - -1 indicates no limit (default)
 - After you create an account, you can also set the number of additional ports available for routes to use (Additional Burst Ports) after the maximum number of ports have been used up. For more information about setting Additional Burst Ports, see Account Route Defaults.
 - The Session Limit for New Account data and the Additional Burst Session data are shown separately in Recording Usage Reports and are subject to your licensing agreement.
9. Click **Create** to create the new account. The Edit Account page displays.

Configuring/Editing Details for an Account

Super Users and Account Administrators can configure or edit the details for any of the accounts on the Accounts page. Tenant Administrators can configure or edit the details for their own accounts only.

After selecting an account on the Accounts page, you can click **Edit** and make changes to the following:

- Account Configurations
- Archival Configurations
- Dashboard Configurations
- LDAP Configurations
- Permissions
- Route Defaults
- Routes
- Users
- Video Configurations

Edit Account Configurations

You can edit the general information for an account when required.

To edit the Account Configurations:

1. On the Admin page, click **Accounts**. The Accounts page displays.
2. Select an account from the list and click **Details**. The following page displays.

Accounts

3. **Account Name**—Edit the account name.
4. **Description**—Edit the description for this account.
5. **Recording is**—Select whether or not to enable recordings on this account. Valid values are:
 - Enabled (default)
 - Disabled
6. **Segmentation State**—Select whether or not to enable recording segmentation via FACE API requests or reINVITES.
7. **Session Capacity**—Edit the maximum number of call recording sessions simultaneously available for routes to use on this account. When the maximum session capacity is reached across all routes on the account, a recording may indicate to the caller that all lines are busy and to call back at another time. Valid values are:
 - 1 to 999999999 (must indicate total number of licensed sessions)
 - -1 indicates no limit (default)
 - The maximum session limits for an Account are subject to your licensing agreement.
 - After you create an account, you can set the Additional Burst Sessions available for routes to use after the maximum number of sessions have been used up. For more information about setting Additional Burst Ports, see Route Capacity Defaults.
 - The maximum session limit and the available burst session data is included in the Usage and Billing Reports. For more information about generating reports, see Managing Reports.
8. Click **Update** to save the changes to the account.

Archival Configurations

You may define an archival strategy for each account, using the Account's **Archival Configuration** page.

To add an Account-specific Archival destination:

1. On the Admin page, click **Accounts**.
2. Select an account from the Accounts page and click **Edit**.
3. Click **Archival Configurations** and click **Enable Archival by Account** to expand the archival information.



Note:

Archival by account is enabled only when there is a default archiver created.

4. In the **Name** field, enter the name of the Account for which archival is being configured. By default, this field is filled with the name of the Account in which you are working.
5. In the **Remote Access URL** field, enter the URL in which the recordings are archived. Note that locations created automatically by the addition of a valid RSS configure the URL and serve recordings from it. If you add custom locations, you must configure them to be served by a web server and then set this URL if you want them to be playable via the Dashboard or APIs.
6. In the **Access Type** field, select one of the following:
 - Local - Local disk
 - Mount - NFS Mount shared directory
 - SFTP - SFTP server
 - SFTP Port - Specify the port number. Valid values are 0 - 65535. The port must be enabled in the specified host.

Note:

"Local" access in Archival by Account is deprecated and Oracle recommends the "Mount" access type in this scenario.

7. Click **Local/Mount Configurations** and in the **Local Recordings Directory** field, specify the directory of the Account's Archival destination Location. When **Access Type** is set to **SFTP**, the Archiver attempts to move the Account's recordings to the SFTP user "home" path on the SFTP server.
8. Click **Advanced Configurations**. The **Checksum** field enables the MD5 Hash for Recordings feature.

9. Click Create.
10. Click Update.

For more information on configuring Archival by Account, see "Managing Sites".

 **Note:**

Archival for recordings on the enabled Accounts begins immediately after configuration. To avoid errors, confirm that the Local directory path, NFS share, or SFTP server is valid and accessible with your configuration. Note that for NFS shares, they must be mounted to each host that needs to access them, typically each RSS.

Configuring MD5 Checksum Validation

The ISR may use MD5 Hashing to validate files are moved in their entirety.

1. On the Admin page, click **Accounts**.
2. Select an account from the Accounts page and click **Edit**.
3. Click **Archival Configurations** to expand the Archival configuration.
4. Select the Archival Location entry on which you are enabling checksum validation.
5. Click **Advanced Configurations**.
6. Set the **Checksum** field to MD5.
7. Click **Update**.

If a checksum violation occurs, the Recording Details page displays displays an error.

8. Once MD5 Hashing is enabled, you may retrieve the checksum on new recordings. Using an authorized valid token, make a FACE details request. For example:

```
$ curl -k -X GET "https://<face_ip>:8443/Face/audioRecording/
details?token=<token>&filename=<file_name>
```

The following is a truncated sample response:

```
<?xml version="1.0" encoding="UTF-16"?>

<result><code>0</code><message>ACK</message><recording>
...
<checksum>5941ee64142e6eb45dfaef23203cf54</checksum>
<checksumMismatch>>false</checksumMismatch>
<customDataSets/>
<siprecDataSets/>
<dtmfDigits/>
</recording>
</result>
```

Verifying Archival Success

To verify successful Archival for a specific recording.

1. On the Recordings page, select the Recording you are archiving and click **Details**.
2. Click **File Location**.

The Archival Status and Archival Remarks fields provide information about the Archival of a specific recording.

File Location	
Directory	/2019-06-20/09/23
Archival Status	Successfully Archived
Archival Remarks	Recording was archived by archiver ID 2 process ID localhost.localdomain16b992d92b2 at Thu Jun 27 09:43:49 EDT 2019

Site Archival Configuration with Account Archival Enabled

Recordings that do not belong to an Account with Account Archival configured may still need to be moved to another Location, converted for playback, or deleted after a certain amount of time. This is configured through the Sites Archival page.

To edit Archival:

1. Select the "Source" Location in the "Update" form. This may be the RSS's "Primary" Location, or another Location specific to your environment.
2. Select the "Destination" Location, in the "Update" form. This could be the RSS's "Secondary" Location, or another Location specific to your environment.
3. Click **Update**.
4. Confirm, using the Recording Detail page's File Location section, with a recording made on an Account not specifically configured for Archival.

File Location	
Directory	/2019-06-20/09/23
Archival Status	Successfully Archived
Archival Remarks	Recording was archived by archiver ID 2 process ID localhost.localdomain16b992d92b2 at Thu Jun 27 09:43:49 EDT 2019

Troubleshooting Archival

1. Access the Recording Details page.
2. Click the **File Location** section.

File Location	
Directory	/2019-06-20/09/23
Archival Status	Successfully Archived
Archival Remarks	Recording was archived by archiver ID 2 process ID localhost.localdomain16b992d92b2 at Thu Jun 27 09:43:49 EDT 2019

The **Archival Status** and **Archival Remark** comments provide information about the recording's Archival.

Note:

Only converted and wav formatted recording files will be archived to the destination location if the location type is SFTP.

- The Administrator may use the **Reset** button to resolve a problem in the architecture and attempt Archival again for the recording.

 **Note:**

Invalid permissions of the destination directory for the Archival process user or Archival SFTP client user are a common source of Archival failures. For example, invalid SFTP credentials yield an **Archival Remark** reason of "Archive is Aborting due to unable to establish SFTP Session for the Location".

Dashboard Configurations

You can customize the ISR Dashboard for each account using the Account page's Dashboard Configurations section.

- On the Admin page, click **Accounts**.
- Select an account from the Accounts page and click the **Edit** button.
- Click **Dashboard Configurations** to expand the branding information.

8. **Admin Help**—Enter any help information that you want to display when an Administrator clicks the Help icon from any page in the ISR Dashboard. Valid values are text or HTML code. For example:

For help or support, contact ABC, Inc. via support@abc.com.

The default value for this field is:

```
<table cellpadding="0" cellspacing="0" border="0"> <tr> <td valign="top">
<p ><h4>Technical Support</h4></p> </td></tr> <tr><td><a href="https://
support.oracle.com/" TARGET="_blank"><b>Premier Support</b></a> is
available for this product.</td></tr> <tr><td>For questions and problems
that cannot be answered by our <a href="http://docs.oracle.com/cd/
E50378_01/index.htm" TARGET="_blank">documentation</a>, please open a
service request through the Oracle Support Portal: <br/><br/> <a
href="https://support.oracle.com" TARGET="_blank">https://
support.oracle.com</a> <h4>In your service request, please:</h4> <ol>
<li>Identify the component on which you believe the problem resides</li>
<li>Provide a detailed description of the behavior</li> <li>Attach the
appropriate logs: <ul> <li><b>Core Recorder (On RSS Host): ISR.log</b> -- /
cxc_common/ISR/ISRLogs/ISR.log</li> <li><b>Routing API (On RSS Host):
IsrApi.log </b> -- /cxc_common/ISR/ApiLog/IsrApi.log</li>
<li><b>Recording Dashboard (On Dashboard VM Host): production.log</b>
-- /var/www/dashboard/current/log/production.log</li> </ul> </li> </ol>
</td> </tr> </table>
```

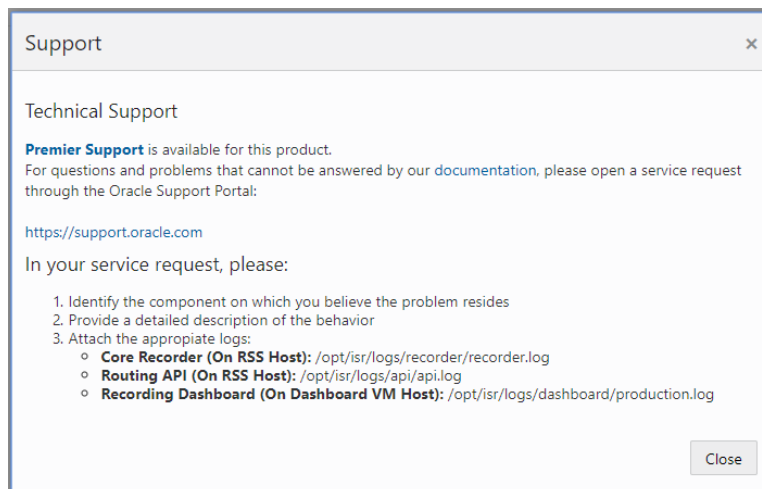

 **Note:**

In the **Admin Help** and **User Help** fields, you can resize the text box as required by left-clicking and holding your mouse button on the bottom-right corner of the box, and dragging it to the size you require.

9. **User Help**—Enter any help information that you want to display when a User clicks the Help icon from any page in the ISR Dashboard. Valid values are text or HTML code. For example:

For help or support, contact ABC, Inc. via support@abc.com.

The default message in the ISR is:

For help, please contact your account administrator.

10. **Max Recording Entries in List View**—The maximum number of recording entries that the Dashboard searches for in the Recordings List View. The default value is **10000**.
11. **Max Recording Entries in CSV Download**—The maximum number of recording entries that the Dashboard searches for when preparing a CSV file for download. The default value is **10000**.
12. Click **Update** to save the changes. The color and logo you specify display on the screens in the ISR Dashboard.

Permissions

The Accounts' Permissions page allows you to configure Account-level playback, deletion, and download recording file permissions through the ISR Dashboard.

Route Defaults

The Accounts Route Defaults page is applied as the default settings for all routes under the selected account. The Route Defaults page allows you to configure the following:

- Recording Defaults
- Recording Notes and Scoring Permissions
- Record and Save Mode Defaults

Accounts

Route Defaults

The **Route Defaults** allow you to specify whether or not recording is enabled by default for the routes that are created on the account. You can also specify the Route mode to use for the recording, the percent of recordings allowed, and the recording format.

To configure recording defaults:

1. On the Admin page, click **Accounts**.
2. Select an account from the Accounts page and click the **Edit** button.
3. Click **Route Defaults** to expand the route default information.
4. Click **Recording Defaults** to expand the recording default information.
5. **Route Mode**—Select the type of recording you want this account to perform by default. Valid values are:
 - Standard (SIPREC)—ISR records as the Session Recording Server (SRS) in a SIPREC architecture.
 - Record and Save—The ISR records calls and only saves them if the Record and Save on DTMF key (see Record and Save Mode Defaults) is pressed by one of the parties on the call. If no key is pressed, the recording is automatically discarded. When you select this option, the **Percent to Record**, **Route Can Record**, and **Default Recording State** parameters become grayed-out.
6. **Recording is**—Select whether or not calls on this route are recorded. Valid values are:
 - Yes (default) - Recording is enabled for all calls on this route.
 - No - Recording is disabled for all calls on this route.
7. **Percent to Record**—Specify a value for the percentage of calls to record on this route. Default is 25. Valid values are:
 - 0 to 100

 **Note:**

When a session is not recorded based on this value, the ISR replies to unrecorded INVITEs with a 412 response code, logs the rejected session, and adds the rejected session to the call statistics table.

When this value is set to **0**, the ISR remains connected and available for ad-hoc API recording for all sessions. When you set this value to 0 and update your ISR, the ISR Dashboard provides the following message:

```
Percent To Record has been set to 0%. Each session is accepted and remains active for ad-hoc recording. To reject sessions due to percentage-based recording, the value must be greater than 0%.
```

8. **Always Record As Raw RTP**—Select **Yes** when multiple transmission codecs are present in a session. If set to **No** with multiple transmission codecs present in a session, the ISR does not record the call properly.

9. **Codec profile Name**—Specify the associated codec profile you want to assign to this account.
10. **Record DTMF**—Select whether routes for this account record DTMF digit presses by default. The default value is **Use System Account's Setting**.

Recording Notes and Scoring Permissions

Recordings in the ISR Administrator Dashboard have specific metadata information that is stored with the actual recording. Some of this information includes Agent ID, rating, notes, and whether or not the recording was completed. For more information about recordings, see *Managing Recordings*.

You specify whether or not routes created for the account allow users, by default, to edit recording information by setting the **Recording Notes and Scoring Permissions** parameters.

To set recording editing permissions:

1. **Allow Editing of Agent ID?**—Select whether or not you want users for this route to edit the Agent ID for a recording. Valid values are:
 - Yes - Allow editing of Agent ID for a recording.
 - No (default) - Prevent editing of Agent ID for a recording.
2. **Allow Editing of Rating?**—Select whether or not you want users for this route to edit the Rating assigned to a recording. Valid values are:
 - Yes - Allow editing of rating for a recording.
 - No (default) - Prevent editing of rating for a recording.
3. **Allow Editing of Completed Transaction?**—Select whether or not you want users for this route to be able to indicate that a recording represents a complete transaction. Valid values are:
 - Yes - Allow editing of completed transaction information for a recording.
 - No (default) - Prevent editing of completed transaction information for a recording.
4. **Allow Editing of Notes?**—Select whether or not you want users for this route to edit the Notes specified for a recording. Valid values are:
 - Yes - Allows editing of notes specified for a recording.
 - No (default) - Prevent editing of notes specified for a recording.

Record and Save Mode Defaults

When the **Route Mode** is set to **Record and Save** (see *Recording Defaults*), you can set the DTMF key that indicates the recording is to be saved. If any other key is pressed, or no key press is received, the recording is discarded.



Note:

The Route Mode parameter **MUST** be set to Record and Save to enable this Record and Save on DTMF parameter.

To set the record and save mode defaults:

- **Record and Save on DTMF**—Select the type of keypress that allows the caller to save their recording from their phone's keypad. This parameter allows you to assign a specific DTMF key (keypress), that when pressed by the caller, stores the recording at their location. The value **dtmf-disabled** disables this feature. Valid values are:
 - dtmf-pound # (default)
 - dtmf-star *
 - dtmf-0
 - dtmf-1
 - dtmf-2
 - dtmf-3
 - dtmf-4
 - dtmf-5
 - dtmf-6
 - dtmf-7
 - dtmf-8
 - dtmf-9
 - dtmf-disabled

Sessions Capacity Defaults

The ISR allows you to set the maximum number of sessions available by default for routes created under the current account. When the maximum session capacity is reached across all routes on the account, a recording may indicate to the caller that all lines are busy and to call back at another time.

You can also set the number of additional call recording sessions available by default for routes to use after the maximum number of sessions has been depleted. The additional burst sessions are used ONLY when the maximum session capacity is reached.

1. **Session Capacity**—Enter the maximum number of sessions to assign by default to new routes for the account. Default is 24. Valid values are:
 - -1 to 999999999 (must indicate total number of licensed sessions)
 - -1 indicates no limit (default)
 - The maximum session limits for an Account are subject to your licensing agreement.
 - The maximum session limit data is included in the Usage and Billing Reports. For more information about generating reports, see Managing Reports.
2. **Additional Burst Session Capacity**—Enter the number of additional call recording sessions to assign by default to routes for the account. These are only used after the maximum number of sessions has been depleted. Default is 6. Valid values are:
 - -1 to 999999999 (must indicate total number of licensed sessions)
 - -1 indicates no limit (default)
 - The additional burst session limits for an Account are subject to your licensing agreement.

- The additional burst session data is included in the Usage and Billing Reports. For more information about generating reports, see Managing Reports.
3. Click **Update** to save the default route parameters. The Edit Account page displays.

Routes

The Routes section of the Edit Account page allows you to view all routes associated with this account.

Accounts

Type	Pattern	Virtual Pattern	Recording is	Percent To Record
To	%	%DNIS%	Enabled	100

Page 1 of 1 (1 of 1 items)

Users

The Users section of the Edit Account page allows you to view all users associated with this account.

Accounts

Name	Email	Type of User	ISR Access
Admin	isradmin@oracle.com	Super User	Enabled

Page 1 of 1 (1 of 1 items)

Video

The Account's Video Configurations page allows you to enable or disable video recording for an Account.

1. On the Admin page, click **Accounts**.
2. Select an account from the Accounts page and click **Details** for that account.

3. Click Video Configurations.

4. In the **Video recording is** field, enable or disable video recording. By default, video recording is disabled.
5. In the **Video Access Permissions** field, specify whether users are allowed to access video recordings. By default, users are enabled.
6. Click **Update**.

LDAP Configurations

The LDAP Configurations section of the Edit Accounts page allows you to configure the ISR system for Dashboard logins using LDAP. The LDAP Configurations page allows you to configure the following:

- Enable LDAP on the ISR Dashboard
- The host URL or IP
- The port number of the LDAP server
- The TLS certificate file to use for secure LDAP requests.

Deleting an Account

You can delete accounts in the ISR Dashboard as required.

**Note:**

The System account is the default account in the Dashboard and cannot be deleted.

To delete an account:

1. On the Admin page, click **Accounts**.
2. Select an account from the Accounts page and click **Delete**.

The following message and prompt displays.

“Deleting this account will delete all recordings, routes, and user types associated with it!

Are you sure you want to delete this account?”

3. Click **Continue** to continue and delete the account and all associated recordings, routes, and user types or click **Cancel** to cancel the delete function.

 **Note:**

Once you delete an account, it cannot be recovered. All routes, users, and recordings associated with the account are lost.

Importing an Account CSV File

You can define accounts in a CSV file and import the data from the file into the ISR database.

 **Note:**

Ensure the values provided in the CSV file match the values in the table provided or the ISR displays an error message.

To import account information from a CSV file:

1. Using any application that can save to a CSV file, create a file that contains the parameters required for creating an account.
 - Boolean (yes/no) values must be entered using 0 (yes or enabled) and/or 1 (false or disabled).
 - The ISR does not ignore any leading and/or trailing spaces, so ensure your CSV file does not have any.

The following table provides the parameters you must enter in the CSV file. Parameters must be entered in the same order presented below.

Parameter Heading	Valid Values
account_name	text
account_description	text
account_misc	text
percent_to_record	0 to 100
recording_enabled	0 1
recorder_state	0 1

Parameter Heading	Valid Values
default_recording_type	1 None: Account or System default (default) 2 WAVE Linear/8bit/8KHz stereo 3 WAVE Linear/16bit/8KHz stereo 4 WAVE Linear/8bit/8KHz mono 5 WAVE Linear/16bit/8KHz mono 6 WAVE uLaw 8bit/8KHz stereo 7 WAVE aLaw 8bit/8KHz stereo 8 WAVE uLaw 8bit/8KHz mono 9 WAVE aLaw 8bit/8KHz mono 10 Raw uLaw 8bit/8KHz mono 11 Raw aLaw 8bit/8KHz mono 12 Raw PCM 8bit/8KHz mono 13 WAVE ADPCM 4bit/8KHz mono 14 WAVE ADPCM 8bit/8KHz stereo
agent_id_editable_flag	0 1
rating_editable_flag	0 1
completed_editable_flag	0 1
notes_editable_flag	0 1
application	pass_through conference record_and_save call_parking vam_sip_test
maximum number of ports	digits (-1 for no limit)
number_of_burst_ports	digits (-1 for no limit)
acct_port_limit	digits

Example File with Parameters and Values

Account Name	Account Description	Account Type	Account Port Limit	Recording Enabled	Recorder State	Play Back Recording Permission	Delete Recording Permission
Acc1	Acc1	1	4	true	1	1	1
Acc2	Acc2	1	5	true	1	1	1
System	System	1	-1	true	1	1	1

2. Save the file as a <filename>.csv file (for example, AccountB.csv).
3. Login to the ISR Dashboard.
4. Click **Admin**.
5. Click **Accounts**. The Accounts page displays.

Accounts

Account Name	Description	Recorder State	Account Port Limit	Video Recording Enabled	Play Back Recording Permission	Delete Recording Permission
Acc1	Acc1	1	4	true	1	1
Acc2	Acc2	1	5	true	1	1
System	System	1	-1	true	1	1

(1-3 of 3 items) | < 1 >

6. Click **Import**.
7. Click **Choose File** and navigate to the CSV file you are importing, select the file and click **Open** to populate the field.
8. Click **Import** to upload the account CSV file to the ISR database.

 **Note:**

The new accounts are added to your Accounts page and display the values that correspond to the values you specified in the CSV file.

The dashboard also provides guidelines for creating your file and a working sample. Click on **Guidelines** to display the parameter names you can use in a CSV file when creating an account.

Click on **Sample File**, and then click on **accounts.csv** to download an example of an accounts CSV file you can use as a guideline.

4

Managing Users

This chapter provides information about the various user access levels you can assign to Users of the ISR Dashboard. It also provides information about adding, editing, and deleting User profiles, and displaying a User Audit log of tasks performed by each User.

Manage Users

Use the **Users** link on the Admin page of the ISR Dashboard to manage User profiles in the ISR network.

An Administrator can add, delete, edit, and view users on the ISR. Applicable user functions are dependent on the user access level assigned to the Administrator. Super Users, Account Administrators, and Tenant Administrators have permissions to manage Users.

Select **Users** from the Admin page to manage Users.

Users Page

Users

User Name	User Email	ISR Access	Account	User Type
Admin	isradmin@oracle.com	0	1	1
apiuser	apiuser@oracle.com	0	1	6

The following table describes the information displayed on the Users Page.

Column	Description
User Name	Name currently assigned to each User.
User Email	Email address of the User. The User enters this email address on the login page. Email address is usually a domain name in the format: <username>@<host server>.<domain name system (.com, .org, .net, .edu, etc.)>
ISR Access	Indicates the current status of the User. Status can be: enabled - Status is active. User can perform functions associated with its user type. disabled - Status is inactive. User cannot perform functions associated with its user type.  Status detected that an error occurred for this User profile.
Account	Primary Account name for which the user is associated.
User Type	User level assigned to this user (Super User, Account Administrator, Tenant Administrator, Tenant User, API User).

User Access Levels

The display of information in the ISR Dashboard is dependent on your user level access. Each user has specific permissions and privileges based on their level of access.

The following table indicates the Dashboard features available for each User type.

Functionality	Super User	Account Administrator	Tenant Administrator	Tenant User	API Users
View/Play Recordings	Yes	Yes	Own Recordings only	Own Recordings only	No
Generate Reports	Yes	Yes	Reports for own Accts only	Reports for own Accts only	No
Edit Dashboard Settings	Yes	Yes	Yes	Yes	No
Manage Realms	Yes	No	No	No	No
Manage Accounts	Yes	Yes	Own Accts only	No	No
Manage Routes	Yes	Yes	Routes for own Accts only	No	No
Manage Authorization Services	Yes	Yes	No	No	No
Manage Users	Yes	Yes	Users for own Accts only	No	No
Manage Sites	Yes	View only	No	No	No
View Live Sessions	Yes	Yes	No	No	-

Note: An API User is specific to the FACE REST API and cannot log into the ISR Dashboard.

Adding a User

Adding a User to the ISR is dependent on your access level permissions. Super Users and Account Administrators can add Users to any account. Tenant Administrators can add Users for their own accounts only. Tenant Users cannot access the Administrator features of the ISR Dashboard.

Use the following procedure to add a user to an account(s).

Note:

You can create a User profile using any application that can save to a comma separated value (CSV) file (i.e., Microsoft® Excel, Notepad®, etc.). Using the ISR Dashboard, you can then import the User profile information from the file (<filename>.csv) to the ISR database.

For more information about importing a User profile into the ISR database, see "Importing a User Profile CSV File".

To add a user:

1. After logging into the ISR Dashboard, click **Admin**.
2. Click **Users**. The Users page displays.
3. Click **Create**. The following page displays.

The screenshot shows the 'Create User' form with the following fields and values:

- Primary Account: System
- Name: (empty)
- Email: (empty)
- Description: (empty)
- Password: (empty)
- Confirm Password: (empty)
- Disable Password Expiry: No
- Preferred Language: en
- Preferred Time Zone: Eastern Time (US & Canada)
- Preferred Time Format: 12 Hours
- Type of User: Account Admin
- ISR Access: Enabled

Buttons: Create, Cancel

4. **Primary Account**—Select the primary account to assign to this User. Valid values are dependent on the accounts currently configured in the ISR, and the permission level of the User. Default is System.
5. **Name**—Enter a name for the user.
6. **Email**—Enter the user's email address. This is the value the User enters in the Email field on the login page.
For example, smith@acmepacket.com.
7. **Description**—Provide a brief description of the user.
8. **Password**—Enter a password for the user to specify when logging into the ISR Dashboard. When a user logs into the Dashboard for the first time with their assigned password, the Dashboard prompts the user to change the password for security purposes.
 - Both letters and numbers
 - At least one case-sensitive letter or special character
 - At least 8 characters long

 **Note:**

This password expires based on the value you configure in the Dashboard Security Settings' **Users Password Expires in** parameter. For more information on configuring this value, see "Managing User Dashboard Security Settings" in this guide.

9. **Confirm Password**—Re-enter the password from Step 7 to verify you entered the password correctly.
10. **Disable Password Expiry**—Specify whether or not this user's password expires.
11. **Preferred Language**—Select the language the user uses. The following are the supported options:
 - en—English (default)
 - es—Spanish
12. **Preferred Time Zone Locale**—Select the time zone locale or the location closest to the user.
13. **Preferred Time Format**—Specify the time format to use.
 - 12 Hours (default)
 - 24 Hours
14. **Type**—Select the user type from the drop-down list to assign to this user. Valid values are
 - Super User
 - Account Admin
 - Tenant Admin
 - Tenant User
 - API User

Available selections in the User Type field are dependent on the permission level of the current user. The following table identifies the values available for each level of access.

User Type	Available User Type Values
Super User	Super User Account Admin Tenant Admin Tenant User
Account Administrator	Account Admin Tenant Admin Tenant User
Tenant Administrator	Tenant Admin Tenant User
Tenant User	N/A
API User	N/A

15. **ISR Access**—Specify whether the user is allowed access to the ISR.
16. Click **Create** to add the new User. The Edit User page displays.

Editing a User Profile

You can edit a User's profile as required. Access to a User profile is dependent on your access privileges.

To edit a User profile:

1. Click **Admin**.
2. Click **Users**. The Users page displays.
3. Choose a User and click **Edit**. The Edit User page displays.

Edit User

← Back

← Previous 1 2 3 4 → Next

User Email Permissions Account Configuration Route Configuration

Primary Account System

Name Admin

Email isradmin@oracle.com

Description

Password

Confirm Password

Disable Password Expiry No

Preferred Language en

Preferred Time Zone Eastern Time (US & Canada)

Preferred Time Format 12 Hours

Type of User Super User

ISR Access Enabled

Update Cancel

4. Edit the parameters for the User as applicable using the procedures defined in "Adding a User".

Note:

For an existing user, if you toggle the **Disable Password Expiry** parameter from **No** to **Yes**, the password expiration time is calculated based on the time the password was last changed.

5. When you are finished editing the User profile, click **Update**. The changes are saved to the ISR database for this User. The following message displays:

Successfully saved.

Showing User Activity

The ISR keeps track of a user's activities while logged into the ISR Dashboard. It logs the following information into a User Audit Trail log:

- Date and time (based on time zone) that the User performed an action.
- Specific action that the User performed.
- Object upon which the action was performed.
- IP address of the User.

You can view the contents of the User Audit Log by clicking the View User Audit Trail icon for a User on the Users page.

To display the User Audit Trail:

1. Click **Admin**.
2. Click **Users**. The Users page displays.
3. Choose a User from the Users page and click **Audit Logs**. The User Audit Trail for that User displays.

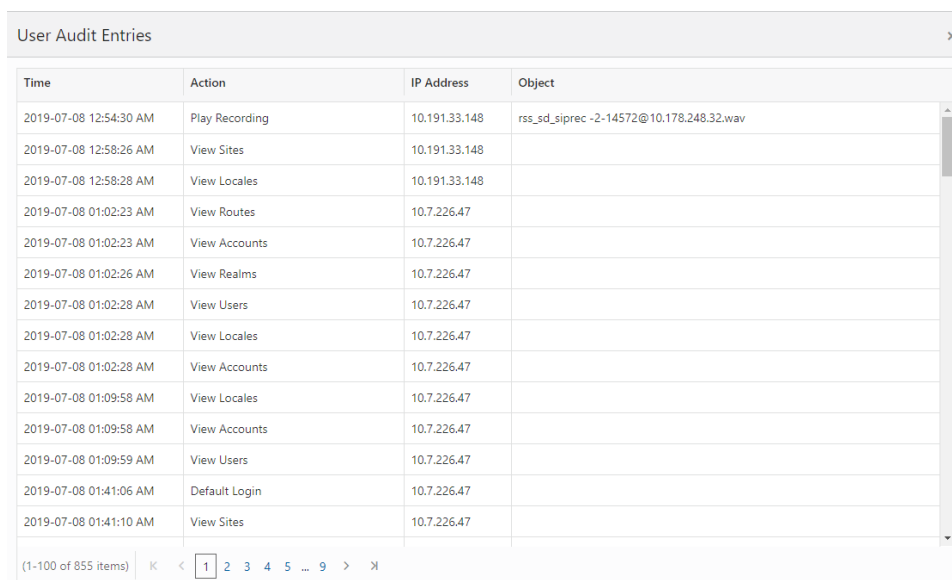

The screenshot shows a window titled "User Audit Entries" with a close button (x) in the top right corner. The window contains a table with four columns: Time, Action, IP Address, and Object. The table lists 15 entries of user activity. At the bottom of the window, there is a pagination control showing "(1-100 of 855 items)" and a set of navigation buttons including a search icon, a left arrow, a page number "1" in a box, and other page numbers "2 3 4 5 ... 9" followed by a right arrow and a refresh icon.

Time	Action	IP Address	Object
2019-07-08 12:54:30 AM	Play Recording	10.191.33.148	rss_sd_siprec -2-14572@10.178.248.32.wav
2019-07-08 12:58:26 AM	View Sites	10.191.33.148	
2019-07-08 12:58:28 AM	View Locales	10.191.33.148	
2019-07-08 01:02:23 AM	View Routes	10.7.226.47	
2019-07-08 01:02:23 AM	View Accounts	10.7.226.47	
2019-07-08 01:02:26 AM	View Realms	10.7.226.47	
2019-07-08 01:02:28 AM	View Users	10.7.226.47	
2019-07-08 01:02:28 AM	View Locales	10.7.226.47	
2019-07-08 01:02:28 AM	View Accounts	10.7.226.47	
2019-07-08 01:09:58 AM	View Locales	10.7.226.47	
2019-07-08 01:09:58 AM	View Accounts	10.7.226.47	
2019-07-08 01:09:59 AM	View Users	10.7.226.47	
2019-07-08 01:41:06 AM	Default Login	10.7.226.47	
2019-07-08 01:41:10 AM	View Sites	10.7.226.47	

The following table describes the information displayed in this User Audit Trail log.

Column Heading	Description
Time	Date and time (based on the time zone of the currently logged in user) when the user performed an action.
Action	Specific action that the user performed.
IP Address	IP address of the User
Object	The file on which the action was performed.

If more entries exist than can appear in the User Audit Trail log, you can use the scroll bar on the right side of the window to scroll through the list of entries.

4. To close the User Audit Trail, click the **X** in the upper-right corner of the window. The Users page displays.

Deleting a User

You can delete users from the ISR database as required.

To delete a User:

1. Click **Admin**.
2. Click **Users**. The Users page displays.
3. Select a User from the Users page and click **Delete**. The following prompt displays:
Are you sure you want to delete this user?
4. Click **Continue** to delete the User from the ISR database. Or click the **X** in the upper-right corner of the box to cancel the delete function.

Importing a User Profile CSV File

You can create user profiles and assign an account to these users using a CSV file. You can then import the data from the file into the ISR database.

Note:

Ensure the values provided in the CSV file match the values in the table provided or the ISR displays an error message.

To import a user profile from a CSV file:

1. Using any application that can save to a CSV file, create a file that contains the parameters required for creating a user profile.
 - Boolean (yes/no) values must be entered using 0 (yes or enabled) and/or 1 (false or disabled).
 - The ISR does not ignore any leading and/or trailing spaces, so ensure your CSV does not have any.

The following table provides the parameters you must enter in the CSV file. Parameters must be entered in the same order presented below.

Note:

At the time a user is created, the ISR saves their email address and no one else can create a user with the same email address, regardless of whether it is uppercase or lowercase.

Parameter Heading	Valid Values
user_name	text

Parameter Heading	Valid Values
user_email	Usually a domain name in the format <username>@<host server>.<domain name system (.com, .org, .net, .edu, etc)>. For example: sample_email@abc.com
description	text
password	text
disable_password_expiry	yes no
user_type	Super User Account Admin Tenant Admin Tenant User API User
account_name	text
login_disabled	0 1
time_zone_locale	Name of the Time Zone Locale (for more information, see "Adding a User")
audit_view_permission	0 1
call_control_permission	0 1
edit_recording_data_permission	0 1
notes_and_scoring_permission	0 1
access_to_all_routes_in_account	0 1

Example File with Parameters and Values

	A	B	C	D	E	F	G	H	I	J	K	L	M	N
1	user_name	user_ema	descriptio	password	disable_password_exp	user_type	account_nan	login_disabl	time_zone_lo	caudit_vie	call_control	edit_recordi	notes_and_sc	access_to_all
2	User 1	user1@sr	sample	Abcd123	yes	tenant usi	system		0	0	0	0	0	0

2. Save the file as a <filename>.csv file (for example, RouteB.csv).
3. Login to the ISR Dashboard.
4. Click **Admin**.
5. Click **Users**. The Users page displays.
6. Click **Import**. The following dialog box displays.

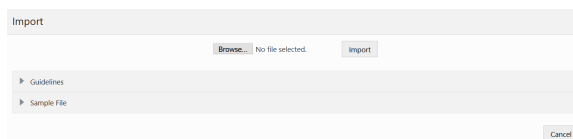

7. Click **Choose File** and navigate to the CSV file you want to import, select the file, and click **Open** to populate the field.
8. Click **Import** to upload the User Profile CSV file to the ISR database.

The new user is added to your Users page and displays the values that correspond to the values you specified in the CSV file.

The dashboard also provides guidelines for creating your file and a working sample. Click **Guidelines** to display the parameter names you can use in a CSV file when creating a route.

Click on **Sample File**, then click **users.csv** to download an example of a route CSV file you can use as a guideline.

5

Managing Realms

This chapter provides information about adding, editing, and deleting realms from the ISR database.

Managing Realms

A realm is a logical way of identifying a domain, a network, a collection of networks, or a set of addresses. Realms are used when an SBC communicates with multiple network elements over a shared intermediate connection. Realms allow for flows to pass through a connection point between two networks.

From an external perspective, a realm is a collection of systems that generates realtime interactive communication sessions comprised of signaling messages and media flows, or a group of multiple networks containing these systems.

From an internal perspective, a realm is associated with SBC configurations to define interfaces and resources in a logical way. Realms are used to support policies that control the collection of systems or networks that generate media sessions.

In the ISR Dashboard, an Administrator can now add, edit, and delete realms using the Manage Realms option on the Admin Menu. After adding a realm, you can then associate an account to that realm. An account can have multiple associated realms and a realm can have multiple associated accounts.



Note:

The configured realm must already exist in the SBC before adding it to the ISR.

How Realm-based Recording Works

The ISR performs recording affiliation and route-matching based on the configured route pattern and the associated realm. The ISR only inspects incoming SIPREC INVITEs for the inclusion of a realm label within the SIPREC extension data. If a realm label exists, it is used to search any configured routes associated with an account(s) in the matching realm. The RSS looks for a To/From match (similar to the way lookups are performed) in the realm's configured accounts and routes.

The following flow diagram illustrates how the ISR performs realm-based recording.

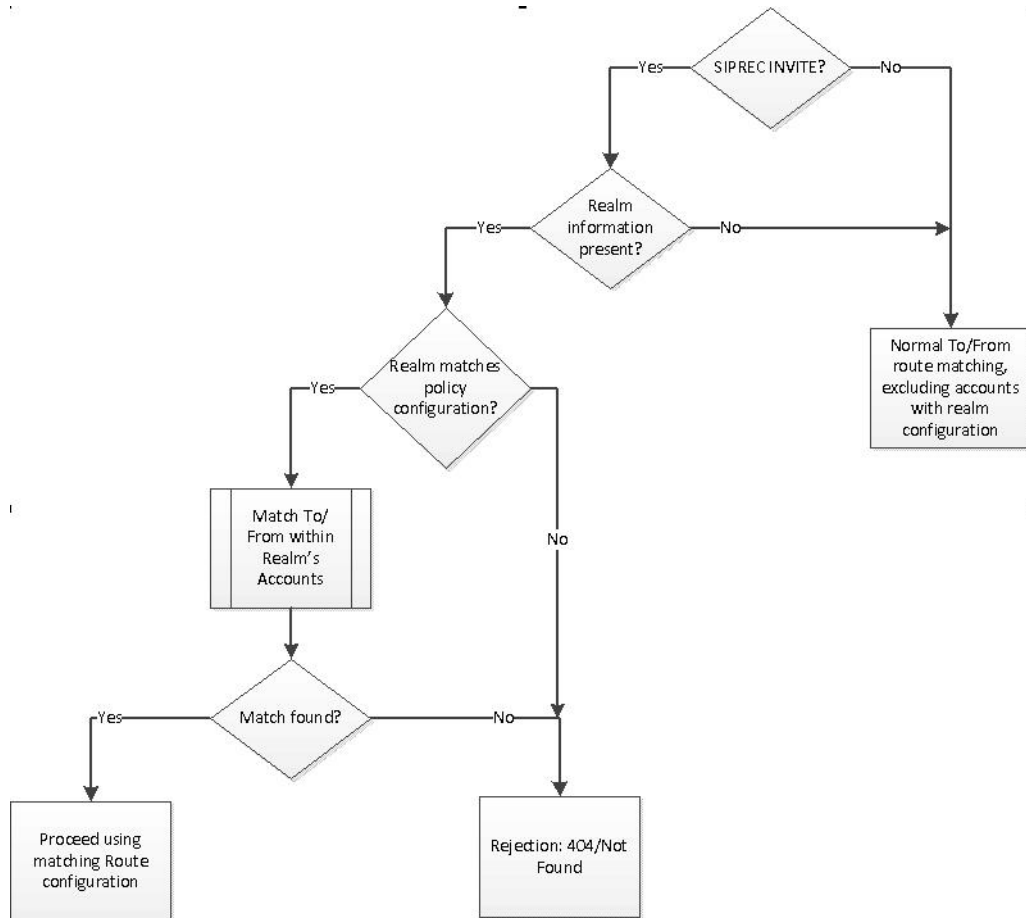

When **adding** a realm, the ISR checks for a wildcard "%" character in the Realm Label. If the wildcard exists, an error message displays. If a wildcard does not exist, the realm is added.

Deleting a realm removes all associations to accounts in the ISR database. The ISR compares the routes of the deleted realm with the routes not in a realm. If there are routes of the same type and pattern in both locations, an error displays and the delete function fails.

In Realm **edit** view, the associated account(s) in the realm display. In the Accounts edit view, the realm(s) associated with the account display only after adding an associated realm(s) to the ISR.

The following rules apply when associating an account(s) to a realm:

- You can associate multiple accounts to a single realm. Routes created on these accounts must have unique route patterns across the related accounts.
- Wildcard routes:
 - are treated like normal 'pattern' routes. They are unique across realms and accounts.
 - can have any priority.
 - if set with a higher priority than a 'distinct' route, the Dashboard displays a warning that the user is about to set a wildcard route higher than the list of lower priority routes, and prompts the user to confirm whether or not to continue.

- You cannot configure wildcard realms.
- Associating a realm with an account(s) is optional. Routes created across accounts with no realms must be unique. This allows the ISR to support legacy (non-SIPREC) installations, as well as maintain compatibility with other SIPREC compliant Session Recording Clients (SRCs).

Use the **Realms** option on the Admin page to manage Realms.

Realms Page

Realms

Label	Description
Realm1	Realm1

The following table describes the information displayed on the Realms page.

Column	Description
Label	Label name assigned to the Realm.
Description	Description of the Realm.

Adding a Realm

You can add a realm to the ISR database using the **Create** button on the Realm page. You can then associate an account to that realm.

To add a realm:

1. After logging into the ISR Dashboard, click **Admin**.
2. Click **Realms**. The Realms page displays.
3. Click **Create**. The following dialog box displays.

4. **Label**—Enter the name of the realm to add to the ISR database.
5. **Description**—(optional) Enter a description for the realm you are adding.
6. Click **Create**. The Edit Realm page displays.

Associating an Account to a Realm

You can associate an account to any realm that exists in the ISR database.

To associate an account to a realm:

1. On the Realms page, select a realm and click **Edit**. The Edit Realm page displays.

2. Click **Account Configuration** to expand the realms page.
3. **Select an Account to add**—Select an account from the drop-down box and click **Add**. A prompt displays asking if you are sure you want to add this account.
4. To add the account to the realm, click **Continue** or to cancel the add function, click the **X** in the upper-right corner of the prompt box.

If you add an account, the account information displays in the "Realm Accounts" page. All routes associated with the account also display in the Realm Routes page.

For more information about editing routes, see "Configuring/Editing Details of a Route".

Editing a Realm

You can edit the realm label and description if required.

To edit a realm:

1. On the Realm list page, select a realm and click **Details**. The Edit Realm page displays.

2. **Label**—Edit the name of the realm.
3. **Description**—Edit the description of the realm.
4. Click **Update**. The following message displays when an updated is successful.
Applied update successfully.

Deleting a Realm

You can delete a realm if required.

To delete a realm:

1. On the Realm list page, select a realm and click **Delete**.

A prompt appears asking if you are sure you want to delete this Realm.

2. Click **Continue** to delete the selected realm or click the **X** in the upper right corner of the box to cancel the delete function.

If you clicked **Continue**, the Realm deletes from the ISR database and from the Realm list page.

6

Managing Routes

This chapter describes how to manage Routes in your ISR network. You can add, edit, and delete routes for accounts as required. You can also assign a route to a Route Group.

Manage Routes

Use the **Routes** link on the Admin page of the ISR Dashboard to manage routes in the ISR network.

A route on the ISR defines the parameters to evaluate and invoke recording, as well as the recording rules to apply for all calls received by the ISR. You can set a specific account to have one route or multiple routes, depending on the subscriber's business requirements.

- If you make changes to a route associated with an account, the changes apply to that route only and do not affect other routes associated with the same account.
- Super Users and Account Administrators can add routes to all existing accounts. Tenant Administrators can add routes to their own accounts only.

Select **Routes** from the Admin page to manage Routes.

Routes Page

Routes

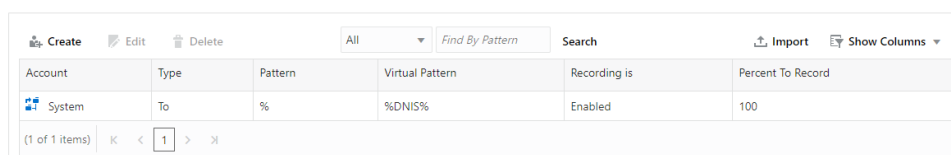

The screenshot shows the 'Routes' page interface. At the top, there are action buttons: 'Create', 'Edit', and 'Delete'. Below these are filters: 'All' (dropdown), 'Find By Pattern' (input), and 'Search'. There are also 'Import' and 'Show Columns' options. The main table has columns: Account, Type, Pattern, Virtual Pattern, Recording is, and Percent To Record. One row is visible with the following data: Account: System, Type: To, Pattern: %, Virtual Pattern: %DNIS%, Recording is: Enabled, Percent To Record: 100. At the bottom of the table, it says '(1 of 1 items)' and has pagination controls.

The following table describes the information displayed on the Routes page.

Column	Description
Account	Name of the Account associated with the route.
Type	Specifies the type of route: From - The incoming call's From SIP URI is compared with the value in the Route Pattern field and must match. To (default) - The incoming call's To SIP URI is compared with the value in the Route Pattern field and must match. From/To - The incoming call's From and To SIP URIs are compared with the value in the Route Pattern field and both must match.
Pattern	Specifies the value to match an incoming call's From, To or From/To value, for applying the appropriate rules of the route and account.
Virtual Pattern	Specifies the destination where the calls matching the route pattern are forwarded once recording rules have been evaluated.

Column	Description
Recording is	Identifies whether or not recording is enabled or disabled on the route. enabled - Recording is enabled. disabled - Recording is disabled.
Percent to Record	Percentage of calls that are allowed to be recorded on this route.

Adding a Route

To add a route:

When adding a new route to an account, by default, the parameters on the Route page are defined from the focused account's Account page details. For example, if you are adding a route to Account A (which already exists with details configured), by default, the new route takes on the configured details from Account A.

Note:

You can create a route using any application that can save to a comma separated value (CSV) file (i.e., Microsoft® Excel, Notepad®, etc.). Using the ISR Dashboard, you can then import the route information from the file (<filename>.csv) to the ISR database.

For more information about importing route information into the ISR database, see [Importing a Route CSV File](#).

A Superuser and Account Administrator can add new routes to all accounts. A Tenant Administrator can add new routes to their own accounts only.

Use the following procedure to add a route and associate an account with that route.

1. After logging into the ISR Dashboard, click **Admin** in the main menu (or **Edit System Configurations** on the Home page).
2. Click **Routes**. The Routes page displays.
3. Click **Create**. The Create Route page displays.

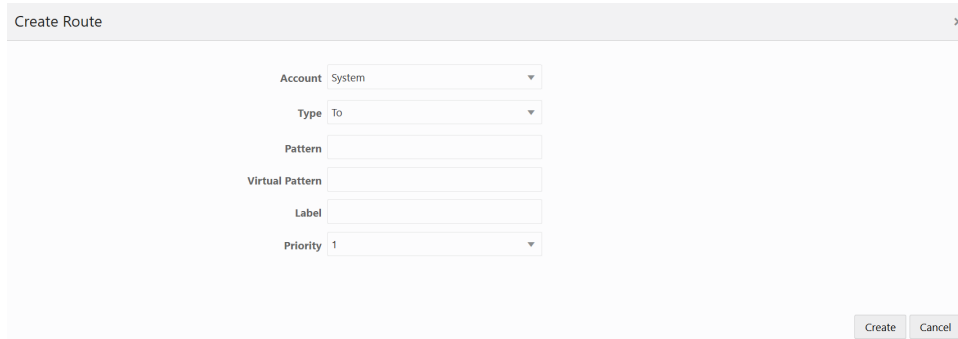

Create Route

Account System

Type To

Pattern

Virtual Pattern

Label

Priority 1

Create Cancel

4. **Account**—Select the account name to associate with this new route. Valid values are dependent on the accounts currently configured in the ISR database, and the User's permission level. The default is **System**.

 **Note:**

Once a route is added and assigned to an account, it cannot be reassigned to other accounts. If you attempt to reassign a route to another account, the following message displays:
Another route with this pattern already exists.

5. **Type**—Select the type of route to use for this account. This field is used to compare with the value in the Route Pattern field. Valid values are:
 - **From** - The incoming call's From SIP URI is compared with the value in the Route Pattern field and must match.
 - **To** (default) - The incoming call's To SIP URI is compared with the value in the Route Pattern field and must match.
 - **From/To** - The incoming call's From and To SIP URIs are compared with the value in the Route Pattern field and both must match.
 6. **Pattern**—Specify the route pattern to use for this account. This field is based on the Route Type selected in step 5 (the SIP URI that triggers this rule set). Use the route pattern value to match an incoming call's From, To or From/To value, and apply the appropriate rules of the route and account. For examples of route patterns, see Examples of Route Patterns.
 7. **Virtual Pattern**—Clicking this field automatically updates the field with the value from the **Route Pattern** field. To change this value, specify the virtual route pattern to use for the current route. This value specifies the destination where the calls matching the route pattern are forwarded once recording rules have been evaluated. The Virtual Pattern is used in conjunction with the Session Agent defined in Managing Sites. A full SIP URI can be provided to override this value. For examples of virtual route patterns, see Examples of Route Patterns.
-
8. **Label**—Enter a name to assign to this route. For display, such as in the recordings view, the route label replaces the value corresponding to the Route Type. For example, in a 'To' route, the 'To' value is replaced with the route label. This may be useful to replace the number given by the service provider with a number more familiar to the users.
 9. **Priority**—Select a priority to assign to this route. Routes with a higher priority number are matched before routes with a lower priority number. Valid values are **1** through **9**. Default is **5**.
 10. Click **Create**. The new route displays on the Routes page.

 **Note:**

The **Virtual Pattern** parameter is only used for application types of Default Pass-Through and Record and Save.

Examples of Route Patterns

SIP INVITES arrive with the following information:

To: user@hostname:port

From: user@hostname:port

You can create routes based on either the From value, the To value, or both, by specifying only the user portion of the URI. The following are examples for setting up route patterns.

Example 1. You want to set up recording rules for calls that come in on a specific 800 number for your billing department, which are answered by a queue at extension 4334.

Since you are evaluating the address the call is sent TO. You need to know what To value your 800 number maps to in your telephony environment. Often, the To is the last 4 digits of the 800 number. To 1234 is the number used in the following example that the 800 number maps to.

- a. Select the Account for which this route applies.
- b. Select Route Type of To.
- c. Set Route Pattern as 1234.
- d. Set Virtual Route Pattern to 4334.

For calls that arrive on To 1234, the ISR applies the rules defined in this route, and then forwards the caller to the value in the virtual route pattern field, extension 4334.

Example 2. You have a high priority customer that you want to make sure gets exceptional service. You know their primary phone number is (333) 555-1234 and you want to be sure to record any call from that number and send that call to your high priority queue at 5445.

Since you want to set the rules based on where the incoming call is coming FROM.

- a. Select the Account for which this route applies.
- b. Select Route Type of From.
- c. Set Route Pattern as 3335551234.
- d. Set Virtual Route Pattern to 5445 (high priority queue).

Example 3. Your largest customer is disputing the number of support tickets they've called in to date, so you'd like to start recording them for future reference. You know their main number is (866) 444-1234 and your customer service To value is 9988. You want to be sure to record any call from that number and send that call to your high priority queue at 5445.

Since you're only interested in calls from a particular number made to your support line, this is a From/To route.

- a. Select the Account for which this route applies.
- b. Select Route Type of From/To
- c. Set Route Pattern as 8664441234/9988.
- d. Set Virtual Route Pattern to 5445 (high priority queue). To override the outbound Session Agent, use sip:5445@10.85.122.15:5060 which sends these calls out their own Session Agent.

Example 4. You want to set up general recording rules for all calls that come in with To numbers to your billing department, and forward them to a destination in your network.

- a. Select the Account for which this route applies.

- b. Select Route Type of To.
- c. Set Route Pattern as %.

The % (wild card) indicates matching of any value for the specified Route Type on the incoming call. In this example, since Route Type is To, any incoming call with a To value will match.



Note:

Wild card routes are typically set to a low priority in order to allow other routes with the same route type to be matched.

Configuring and Editing Details of a Route

Super Users and Account Administrators can configure or edit the details for any of the routes on the Routes page. Tenant Administrators can configure or edit the details for their own Routes only.

After selecting a Route on the Routes page, you can perform the following:

- Edit general Route information
- Configure or edit advanced parameters for a Route
- Upgrade to a Route Group

Edit General Route Information

You can edit the general information for a route when required.

To edit the general route information:

1. On the Admin page, click **Routes**. The Routes page displays.
2. Select a route from the list and click **Details**. The Edit Route page displays.

3. **Type**—Edit the type of route to use for this account. This field is used to compare with the value in the **Route Pattern** field. Valid values are:
 - **From** - The incoming call's From SIP URI is compared with the value in the Route Pattern field and must match.

- **To** (default) - The incoming call's To SIP URI is compared with the value in the Route Pattern field and must match.
 - **From/To** - The incoming call's From and To SIP URIs are compared with the value in the Route Pattern field and both must match.
4. **Pattern**—Edit the route pattern to use for this account. This field is based on the Route Type selected in step 3 (the SIP URI that triggers this rule set). Use the route pattern value to match an incoming call's From, To or From/To value, and apply the appropriate rules of the route and account. For examples of route patterns, see Examples of Route Patterns.
 5. **Virtual Pattern**—Clicking in this field automatically updates the field with the value from the **Route Pattern** field. To change this value, specify the virtual route pattern to use for the current route. This value specifies the destination where the calls matching the route pattern are forwarded once recording rules have been evaluated. The Virtual Route Pattern is used in conjunction with the Session Agent defined in Manage Sites. A full SIP URI can be provided to override this value. For examples of virtual route patterns, see Examples of Route Patterns.

 **Note:**

The Virtual Pattern parameter is used only for application types of Default Pass-Through and Record and Save.

6. **Label**—Edit the name of this route. For display, such as in the recordings view, the route label replaces the value corresponding to the Route Type. For example, in a 'To' route, the 'To' value is replaced with the route label. This may be useful to replace the number given by the service provider with a number more familiar to the users.
7. **Priority**—Edit the priority for this route. Routes with a higher priority number are matched before routes with a lower priority number. Valid values are **1** through **9**. Default is **5**.
8. Click **Update** to save the changes.

Route Advanced Configurations

The Route Advanced Configurations on the Routes page allows you to configure:

- Recording parameters
- Video Recording parameters
- Recording Editing Permissions
- Record and Save Mode parameters
- Archiving parameters
- Capacity parameters

Recording

The Recording section of the Edit Route page allows you to configure recording properties for a particular route.

To configure the route recording properties:

1. From the Routes page, select a route and click **Edit**. The Edit Routes page displays.
2. Click **Advanced Configuration**.
3. Click **Recording**.
4. **Route mode**—Select the type of recording you want this route to perform. Valid values are:
 - Standard (SIPREC)—ISR records as the Session Recording Server (SRS) in a SIPREC architecture.
 - Record and Save—The ISR records calls and only saves them if the Record and Save on DTMF key (see Record and Save Mode Defaults) is pressed by one of the parties on the call. If no key is pressed, the recording is automatically discarded. When you select this option, the **Percent to Record**, **Route Can Record**, and **Default Recording State** parameters become grayed-out.
5. **Recording is**—Select whether or not calls on this route are recorded. This parameter is enabled by default.
6. **Segmentation State**—Specify the type of segmentation recording you want to use for this route.
 - Enabled—Segmentation is always on
 - Disabled—Segmentation is always off
 - Ad-Hoc Only—Segmentation may only occur in the "ad-hoc" recording mode
 - Default to Account—Segmentation follows the Route's Account configuration.
7. **Percent To Record**—Specify a value for the percentage of calls to record on this route. Valid values are 0 - 100. The default value is 25.

8. **Always Record As Raw RTP**—Select `Yes` when multiple transmission codecs are present in a session. If set to `No` with multiple transmission codecs present in a session, the ISR does not record the call properly.
9. **Recording Format Profile**—Select the recording format profile you want to assign to this account. The default value is **Use System Account's Profile**.
10. **Record DTMF**—Select whether routes for this account record DTMF digit presses by default. The default value is **Use System Account's Setting**.
11. Click **Update**.

For information on the remaining "Recording Advanced Configuration" fields, see "Recording Defaults".

Video

You can enable or disable video recording for a Route.

1. On the Admin page, click **Routes**.
2. Select a route from the Routes page and click **Edit**.
3. Click **Video** to expand the video information.
4. In the **Video recording is** field, enable or disable video recording. By default, video recording is disabled.
5. In the **Video Access Permissions** field, specify whether users are allowed to access video recordings. By default, users are enabled.
6. Click **Update**.

Recording Notes and Scoring Permissions

The Recording Notes and Scoring Permissions section of the Edit route, Advanced Configuration page allows you to set permissions for recording notes and scoring. You can configure the following:

- Editing of the Agent ID
- Editing of a Rating
- Editing of a Completed Transaction
- Editing of Notes

Record and Save Mode

For information about configuring the **Record and Save Mode** fields, see Record and Save Mode Defaults.

Archiving

The ISR allows you to specify the minimum number of days to store the recordings associated with a route and account. From the **Routes, Advanced Configuration, Archiving** page, set this value using the **Keep Recordings for** parameter. The Recording and Storage Server (RSS) in the ISR manages the storage of the recordings.

Capacity

For information about configuring the **Capacity** fields, see Sessions Capacity Defaults.

Route Members

A Route Group is a group of routes for a specific account, with the same parameters that are associated with the route in focus (Master Route). You can add or delete multiple routes to/from a Route Group as required. Adding routes to a Route Group ensures that all of the routes in the group have the same rules as the Master Route. All routes in the group must be of the same type (To, From, From/To).

To set up a Route Group, you must have a Master Route previously created with the desired parameters (recording percentage, file formats, announcements, custom data fields, etc.). To create a Master Route, see "Adding a Route".



Note:

All Changes made to a Master Route apply to all of the routes in the Route Group.

Adding a Route to a Route Group

To add a route to a Route Group:

1. Ensure you have a route configured that you want to use as the Master Route.
2. On the Admin page, click **Routes**. The Routes page displays.
3. Select the route that you want to use as the Master Route, and click **Details**. The following page displays.

4. Click **Create**. The **Create Route Member** dialog box displays.
5. **Pattern**—Specify a route pattern to use for this route. This field is based on the Route Type currently set for the Master Route. Use the route pattern value to match an incoming call's From, To or From/To and apply the appropriate rules of the route and account. For examples of route patterns, see Examples of Route Patterns.
6. **Virtual Pattern**—Specify the value of the destination where the calls matching the route pattern are forwarded once recording rules have been evaluated. This value can be a To

number. If you defined a Session Agent at Manage Sites, a full SIP URI can override this number. For example of route patterns, see Examples of Route Patterns.

 **Note:**

The Virtual Pattern parameter is used only for application types of Default Pass-Through and Record and Save.

7. Click **Create** to add the Route to the Route Group. The Edit Route page displays with a **Route Members** tab available.
8. Add additional Member Routes to the Route Group if required by clicking **New Member Route** and repeat Steps 5, 6, and 7.

Deleting a Route

You can delete routes in the ISR Dashboard as required.

To delete a route:

1. On the Admin page, click **Routes**.
2. Select a Route from the Routes page and click **Delete**. The following message and prompt displays.

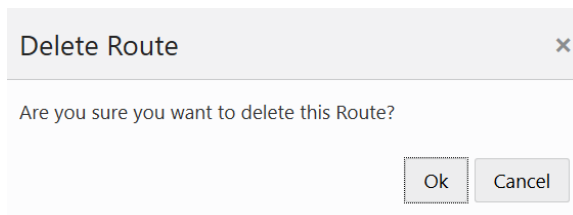
 **Note:**

When you delete a route, the recordings associated with the route continue to exist in the system and are not removed by Archiver retention policies. If these recordings need to be deleted, it must be done manually.

3. Click **OK** to continue and delete the route and all associated web service appliances and data or click **Cancel** to cancel the delete function.

 **Note:**

Once you delete a route, it cannot be recovered. All associated web service appliances and data, as well as any associated route group members are deleted.

Importing a Route CSV File

You can create routes for an account(s) in a CSV file and import the data from the file into the ISR database.



Note:

Ensure the values provided in the CSV file match the values in the table provided or the ISR displays an error message.

To import route information from a CSV file:

- Using any application that can save to a CSV file, create a file that contains the parameters required for creating a route.
 - Boolean (yes/no) values must be entered using 0 (yes or enabled) and/or 1 (false or disabled).
 - The ISR does not ignore any leading and/or trailing spaces, so ensure your CSV does not have any.

The following table provides the parameters you must enter in the CSV file. Parameters must be entered in the same order presented below.

Parameter Heading	Valid Values
route_type	0 From 1 To 2 From/To
route_pattern	text
virtual_route_pattern	text
label	text
priority	0.1 to 0.9
account_name	alpha-numeric characters
percent_to_record	0 to 100
recording_enabled	0 1
default_recording_type	1 None: Account or System default (default) 2 WAVE Linear/8bit/8KHz stereo 3 WAVE Linear/16bit/8KHz stereo 4 WAVE Linear/8bit/8KHz mono 5 WAVE Linear/16bit/8KHz mono 6 WAVE uLaw 8bit/8KHz stereo 7 WAVE aLaw 8bit/8KHz stereo 8 WAVE uLaw 8bit/8KHz mono 9 WAVE aLaw 8bit/8KHz mono 10 Raw uLaw 8bit/8KHz mono 11 Raw aLaw 8bit/8KHz mono 12 Raw PCM 8bit/8KHz mono 13 WAVE ADPCM 4bit/8KHz mono 14 WAVE ADPCM 8bit/8KHz stereo

Parameter Heading	Valid Values
agent_id_editable_flag	0 1
rating_editable_flag	0 1
completed_editable_flag	0 1
notes_editable_flag	0 1
application	pass_through conference record_and_save call_parking vam_sip_test
maximum number of ports	digits (-1 for no limit)
number_of_burst_ports	digits (-1 for no limit)
minimum_storage_days	0 to 365

Example File with Parameters and Values

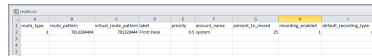

- Save the file as a <filename>.csv file (for example, RouteB.csv).
- Login to the ISR Dashboard.
- Click **Admin** in the main menu (or **Edit System Configurations** on the Home page).
- Click **Routes**. The Route page displays.
- Click **Import**. The following dialog box displays.

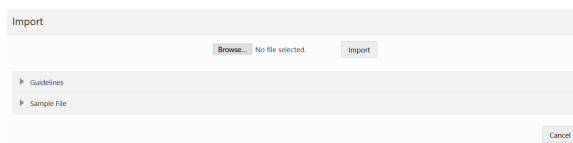

- CSV File to Upload**—Click **Choose File** and navigate to the CSV file you are importing, select the file and click **Open** to populate the field.
- Click **Upload** to upload the route CSV file to the ISR database.

Note:

The new route is added to your Routes page and displays the values that correspond to the values you specified in the CSV file.

The dashboard also provides guidelines for creating your file and a working sample. Click on **Guidelines** to display the parameter names you can use in a CSV file when creating a route.

Click on **Sample File**, and then click on **routes.csv** to download an example of a route CSV file you can use as a guideline.

7

Managing Authorization Services

This chapter provides information about using Authorization Services (3rd party servers) in your ISR network for users to log into when accessing the ISR Dashboard. It also includes information about adding, editing, and deleting Authorization Services.

Manage Authorization Services

Use the **Authorization Services** link on the Admin page of the ISR Dashboard to manage 3rd party servers in the ISR network.

The ISR supports 3rd party authorization services, sometimes referred to as single sign-on. Once a third-party authorization service is properly configured on the ISR, users registered with the third-party platform log into the ISR Dashboard with authorization from the added service. The user's account is then associated with unique fields and values returned from the authorization service. These fields and values can also be found in the metadata of certain sessions stored in the ISR. When the user requests the recordings listing in the Dashboard, only the recordings with matching metadata are shown and playable.

Once the registered third-party user has logged in successfully through the ISR Dashboard, the user's account is registered with the local ISR platform as well. This enables administrative features for that user, such as changing ISR Dashboard settings, specific permissions (ie., allowing recording edits and deletes) or level of access.

As a default security measure, third-party authorization users have only Tenant User privileges when they first log in. For example, in a deployment enabled for Broadworks third-party authorization, a successful Broadworks log in returns a user ID and group ID unique to that user. Initially the user can only see and hear recordings specific to their user and group ID. However, an administrator can update a user's privileges and level of access. If given Account Administrator status, the third-party authorization user can see and hear their own recordings, as well as recordings for everyone within their group. For more information on user level access, see Managing Users.

Select **Authorization Services** from the Admin page to manage Authorization Services.



Note:

Only Super Users and Account Administrators have access to managing Authorization Services for other users.

Authorization Services Page

Authorization Services

Name	Service URL	Status	SRC Type
http://ews.xdp.broadsoft.com/webservice/services/ProvisioningService?wsdl		Enabled	default

The following table describes the information displayed on the Authorization Services page.

Column	Description
Name	Name of the Authorization Service.
Service URL	Specifies the Uniform Resource Locator (URL) associated with the Authorization Service.
Status	Identifies the current status of the Authorization Service on the ISR. Values can be: enabled - Authorization Service is enabled. disabled - Authorization Service is disabled.
SRC Type	Session Recording Client (SRC) type associated with the 3rd Party server. For example, Broadworks. Default is default.

Adding an Authorization Service

You can add an Authorization Service associated with a 3rd party server (such as the Broadworks server) that controls the secure login and authorization of users using the ISR and logging into the ISR Dashboard. Add an Authorization Service using the **New Authorization Service** link on the Authorization Services page.



Note:

Access to an Authorization Service is dependent on your access privileges (Super Users and Account Administrators only).

To add an Authorization Service:

1. After logging into the ISR Dashboard, click **Admin** in the main menu (or **Edit System Configurations** on the Home page).
2. Click **Authorization Services**. The Authorization Services page displays.
3. Click **Create**. The Create Authorization Service page displays.

[< Back](#) **Create Authorization Service**

Name

Service URL
(e.g. http://xsp2.xdp.broadsoft.com:80/webservice/services/ProvisioningService?wsdl)

Status

SRC Type

- Name**—Enter the name of the Authorization Service (3rd party server).
- Service URL**—Enter the Uniform Resource Locator (URL) of the Authorization Service (3rd party server). For example, http://ews.xdp.broadsoft.com/webservice/services/ProvisioningService?wsdl.
- Status**—Select whether or not to enable the Authorization Service (3rd party server) in the ISR network. Valid values are:
 - Yes (default) - Enable the Authorization Service (3rd party server) to be used in the ISR network.
 - No - Prevents the Authorization Service (3rd party server) from being used in the ISR network.
- SRC Type**—Select the type of Session Recording Client (SRC) you are using in your ISR network.
- Click **Create**. The new Authorization Service displays on the Authorization Services page.

Editing an Authorization Service

You can edit the details of an Authorization Service (3rd party server) as required.



Note:

Access to an Authorization Service is dependent on your access privileges (Super Users and Account Administrators only).

To edit an Authorization Service:

- Click **Admin** in the main menu (or **Edit System Configurations** on the Home page).
- Click **Authorization Services**. The Authorization Services page displays.
- Choose an Authorization Service and click **Details**. The Edit Authorization Service page displays.
- Edit the parameters for the Authorization Service as applicable using the procedures defined in "Adding an Authorization Service", starting at Step 4.
- When you are finished editing the Authorization Service, click **Update**. The changes are saved to the ISR database and display on the Authorization Service page.

Deleting an Authorization Service

You can delete an Authorization Service(s) (3rd party server) from the ISR database as required.



Note:

Access to an Authorization Service is dependent on your access privileges (Super Users and Account Administrators only).

To delete an Authorization Service:

1. Click **Admin** in the main menu (or **Edit System Configurations** on the Home page).
2. Click **Authorization Services**. The Authorization Services page displays.
3. Choose an Authorization Service and click **Delete**. The following prompt displays:
Are you sure you want to delete this Authorization Service?
4. Click **Continue** to delete the Authorization Service from the ISR database or click the **X** in the upper-right corner of the box to cancel the delete function.

8

Custom Data

This chapter provides information about viewing and editing the custom data master list, custom data field session values, and using custom data fields advanced search options.

Viewing and Editing the Custom Data Master List

You configure the "master list" of Custom Data Field names via the ISR Dashboard.

Within the **Admin** tab, click **Custom Data Fields**. The Custom Data Field management page [Custom Data Field](#)



Name
samplefield1
samplefield2

(1-2 of 2 items) | < 1 >

appears.

To add a new field name click **Create**.

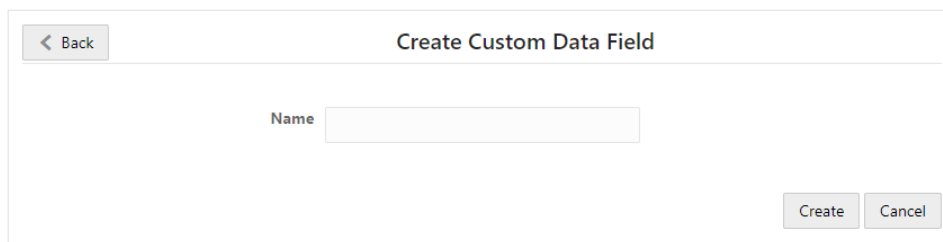

< Back Create Custom Data Field

Name

Create Cancel

To edit and view the details of a Custom Data Field, select the Custom Data Field and click **Details**.

You can delete a Custom Data Field entry by clicking the delete icon.

Note:

If values exist in any recordings for that Custom Field name, that Custom Field name cannot be deleted or edited, the only exception being that letters can be switched between upper and lower case.

Viewing and Editing Custom Data Field Session Values

Once the Master List has been generated and recordings are available in the Dashboard, you may manually add, edit, and delete Custom Data Field values via the Dashboard. In the **Recordings** list, click on a recording and click **Details**. Click on the Recording or any Segments tab, and click the **Custom Data Fields** section for options to add a custom data field, edit an existing value, or delete a value.

Account	System	Duration	2 seconds	Delete
Session ID	x-isr-ucid-1-28879@10.178.248.32	Time	2019-06-20 05:21:39 AM	Update
From	7777			
To	6666			

Name	Value
samplefield1	To
samplefield2	From

Page 1 of 1 (1-2 of 2 items) | < 1 >

Custom Data Fields Advanced Search

To find recordings via the Advanced Search option, click the **Recordings** tab's **advanced search** button. Click **By Custom Data Search Options**. Enter a Custom Data Field name and click **Search**. The ISR returns any recordings associated with the Custom Data Field name and value, along with any other "AND" or "OR" advanced search parameters.

Advanced Search ✕

Select Mode

Partial Match

Session ID

From

To

Label

Search Date By Relative
 By Range

▶ More Recording Search Options

▶ By Segment Search Options

▲ By Custom Data Search Options

samplefield1

samplefield2

▶ By Session Search Options

9

External Event Destinations

This chapter provides information about viewing and editing the external event destinations.

The External Event Notification feature provides a way to notify RESTful services of events occurring in the ISR. It can be used in two ways: to notify third-party applications of new recordings, new sessions, and updates to existing sessions and recordings, or to notify new ISR components, acting as integrations to third-party platforms, of critical ISR events.

The external event notification system propagating session and recording events to the FACE server, which in turn interoperates with the ObserveIT Visual Session Recording solution is an example of ISR events communicating with a third-party application. These notifications provide data that allows the service to coordinate ISR recordings with ObserveIT screen capture recordings, providing simultaneous audio and video playback on applications such as the ISR Dashboard.

External Event Notifications

The External Event Notification feature provides a way to notify RESTful services of events occurring in the ISR. It can be used in two ways: to notify third-party applications of new recordings, new sessions, and updates to existing sessions and recordings, or to notify new ISR components, acting as integrations to third-party platforms, of critical ISR events.

When communicating with third-party applications, the external event notification system propagates session and recording events to a separate server that interoperates with the ObserveIT Visual Session Recording solution (the ISR FACE feature). The data provided in these notifications allows the service to coordinate ISR recordings with ObserveIT screen capture recordings in order to provide simultaneous audio and video playback on applications such as the ISR Dashboard.

Note:

The ISR encodes the URL parameter values in UTF-8 format before sending them to the external server. However, the base URL is left unencoded and the destination server must decode the URL into UTF-8 format.

External event notifications may be configured with a series of default settings for interoperation with ISR FACE and the ObserveIT Visual Session Recording solution. For more information on the interaction between ISR FACE and ObserveIT Visual Recording solution, see the "Face Policy System" section of this guide. If you require more extensive external event notification configuration, contact your Oracle representative.

Configuring External Event Destinations

You configure the External Event Destinations via the ISR Dashboard.
To add or edit an External Event Destination:

1. After logging into the ISR Dashboard, click Admin in the main menu (or **Edit System Configurations** on the Home page).
2. Click the **External Event Destinations** link.
3. **Event Type**—Select the event type to trigger a notification.
 - RECORDING_STARTED_EVENT—Recording has started
 - RECORDING_PAUSED_EVENT—Recording paused
 - RECORDING_RESUMED_EVENT—Recording has resumed
 - RECORDING_ENDED_EVENT—Recording has ended
 - SEGMENT_STARTED_EVENT—Recording segment has started
 - SEGMENT_ENDED_EVENT—Recording segment has ended
4. **Base Service URL**—Enter the URL of the server receiving the HTTP request.
5. **URL Parameters**—Specify any parameters to be added to the request.

 **Note:**

For more information on event parameters and events, either click the **URL Parameters Help** link or see "External Events Notifications" in the *API Guide*.

External Event Configuration Example

Setting the **Event Type** to `RECORDING_STARTED_EVENT` and **Event Policy By** set to the "System" Account to send requests to the Base Service URL

```
https://myisreventreceiver.oracle.com:8443/handleIsrNotification" with  
the URL Parameters  
"event=AudioRecodingStarted&calledAors=%CALLED_AORS%&ucid=%INGRESS_CALL  
ID%
```

would submit an HTTP request in a similar way to entering the following example URL in your web browser:

```
https://myisreventreceiver.oracle.com:8443/handleIsrNotification?  
calledAors=sip:+12356789000@10.1.2.3&ucid=x-isr-ucid-1-24360@10.10.1.2
```

10

Managing Locales

This chapter provides information about offering the ISR Dashboard in languages other than English.

Manage Locales

For users looking to extend their branding and offer the ISR Dashboard in languages other than English, you can upload transcriptions of static dashboard text. Transcriptions are not provided by Oracle, but detailed instructions on how to upload translations, and a sample file are, making it easy to extend the ISR Dashboard.

Adding a New Locale

You can create, import, and set a new locale by completing the following procedure on the Dashboard:

1. Navigate to the Admin page and click **Locales**.
2. Click **Import**.
3. Read the provided guidelines.
4. Click **Sample File** and click the provided **en.txt** English sample for a template for your locale.
5. Copy the content starting at the root element "en" and ending at "multi_page_html" and paste it into a local text file or editor.
6. Save the file as "<root_element>.txt", where <root_element> is the ISO language code. A comprehensive list of ISO-639-1 language codes can be found in https://www.w3schools.com/tags/ref_language_codes.asp.
7. Update the strings with the translations appropriate for the chosen language/locale.
8. Click **Choose File**, select the file, and click **Import**.

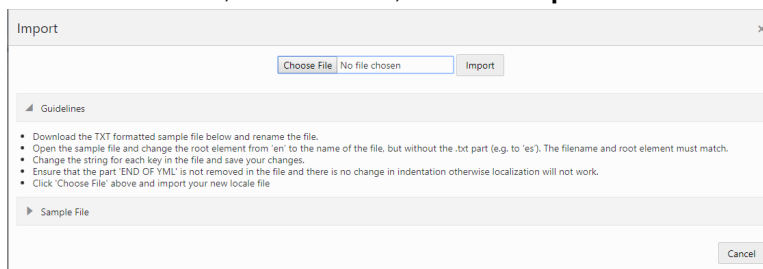

9. Set the "Preferred Language" for the User or Account (in "Branding and Language") to the new locale root element value.
10. Log in and confirm your changes.

11

Managing Recording Format Profiles

With the addition of wideband codec support, the ISR now supports 16 KHz sampling and recording in addition to 8 KHz. To support mixed sampling rates for transmission codecs and recording formats, you can now create and manage your recording format preferences. Managing your recording format profiles also helps you choose the appropriate recording format when multiple transmission codecs are present in a session.

The **Recording Format Profiles** link under the Admin tab allows you to make decisions about file sizes and recording quality so you can apply them to accounts and routes.

There are five Recording Format Profiles:

- Best Quality
- Default
- Small
- Smallest
- Firefox Compatible

By clicking on a codec profile, you can edit its name, provide it a description, select a recording preference for instances where multiple transmission codecs are used in a session, and configure a recording format mapping.

You can configure a recording preference for each recording format profile. This means in cases where multiple transmission codecs are present within one raw RTP file and the codec mappings for each are not the same recording format, the ISR converts the raw RTP into a recorded file based on the profile's size versus recording preferences setting. This is an integer value from 0-100 and in the ISR's GUI, this is configured using a sliding bar which you can drag to your desired position between Small File Size and Best Quality. The ISR selects the recording format with the weighted size to quality ratio closest to your size versus recording preference.

When handling particular transmission codecs which do not match the bit-size or sampling rate of the recording format, the ISR performs up-sampling or down-sampling to conform the audio to the chosen destination format.

Within a recording format profile, you can also configure recording format mappings. This allows you to select a recording format for each of the four supported transmission codecs, g.711 mulaw, g.711 alaw, g.722, and g.729.

Editing a Recording Format Profile

To edit a recording format profile:

1. After logging into the ISR Dashboard, click **Edit System Configurations** or click **Admin** in the top menu bar.
2. Click **Recording Format Profiles**.

A list of all five recording format profiles displays.

3. Select a recording format profile and click **Edit**.
The Edit Recording Format Profile page appears.

4. **Name**—Enter a name for this recording format profile.
5. **Description**—Enter a brief description of this recording format profile.
6. **Preferences**—Drag the slide-bar to the appropriate space between Small File Size and Best Quality based on the recording preference for this recording format profile.

Recording Format Mappings Configuration

To configure Recording Format Mappings:

1. Click **Recording Format Mappings** in the Edit Recording Format Profile page.
2. Beside each Transmission Codec, select a Recording Format from the drop-down list.
3. Click **Update**.

Applying Recording Format Profiles to Accounts

To apply Recording Format Profiles to Accounts

1. After logging into the ISR Dashboard, click **Edit System Configurations** or click **Admin** in the top menu bar.
2. Click **Accounts**.
A list of all accounts configured on the ISR displays.
3. Select the account on which you are applying a recording format profile and click **Edit**. Click **Route Defaults**.

Accounts

4. **Always Record as Raw RTP**—Select **Yes** when multiple transmission codecs are present in a session. If set to **No** with multiple transmission codecs present in a session, the ISR will not record the call properly.
5. **Recording Format Profile**—Select the recording format profile you want to assign to this account. The default value is **Use System Account's Profile**.
6. Click **Update**.

Applying Recording Format Profiles to Routes

To apply Recording Format Profiles to Routes

1. After logging into the ISR Dashboard, click **Edit System Configurations** or click **Admin** in the top menu bar.
2. Click **Routes**.
A list of all routes configured on the ISR displays.
3. Select the route on which you are applying a recording format profile and click **Edit**.
4. Click **Advanced Configurations**.

5. **Always Record as Raw RTP**—Select **Yes** when multiple transmission codecs are present in a session. If set to **No** with multiple transmission codecs present in a session, the ISR will not record the call properly.
6. **Recording Format Profile**—Select the codec profile you want to assign to this account.

7. Click **Update**.

Route Recording File Permissions

The Route Recording File Permissions on the Routes page allow you to configure route-level playback, deletion, and download recording file permissions through the ISR Dashboard.

The screenshot shows the 'Edit Route' configuration page. At the top, there is a navigation bar with a '< Back' button on the left and a 'Next >' button on the right. Below this is a progress indicator with four steps: 1. Route Configuration, 2. Advanced Configuration, 3. Permissions (highlighted in blue), and 4. Route Members. Below the progress indicator, there are three permission settings, each with a green 'Yes' radio button selected: 'Play Recording Permission', 'Download Recording Permission', and 'Delete Recording Permission'. At the bottom right of the form, there are 'Update' and 'Cancel' buttons.

12

Managing Security Settings

The Admin Manage Security Settings link allows you to configure dashboard security settings. Using this link you are able to configure password expirations, user lockout durations, maximum failed login attempts before lockout, and whether or not a user can view a forgotten password page.

To Configure Dashboard Security Settings:

1. After logging into the ISR Dashboard, click **Edit System Configurations** or click **Admin** in the top menu bar.
2. Click **Security Settings**.

Security Settings

User Settings	
Users Password Expires in	90
User Lockout Duration	1,800
User Max Failed Logins Before Lockout	5
Show Forgotten Password Page?	No
Allow HTTP Cache of Recording files	No
Internal API Authorization Type	Token
Internal API Authorization Session Expires in	3,600

SMTP Configurations	
From Email Address	isradmin@oracle.com
Host	
Port	25
Username	
Password	

3. **Users Password Expires in**—Specify the number of days after which users' passwords expire. The default value is **90**.
4. **User Lockout Duration**—Specify the number of minutes a user must wait before attempting to log in again after reaching the User Max Failed Logins Before Lockout value. The default value is **30**.
5. **User Max Failed Logins Before Lockout**—Specify the number of failed login attempts allowed before the ISR locks a user out.
6. **Show Forgotten Password Page?**—Specify whether or not a user can view a Forgotten Password Page. The default value is **no**.

 **Note:**

You can reset the password by enabling this setting. The forgot password reset link is valid only for the duration of the configured User Lockout set time. The default is 30 minutes. After the link becomes invalid, you must request a new link again.

7. **Allow HTTP Cache of Recording files?**—Specify whether the ISR includes the following HTTP header, `Cache-Control: max-age=0, no-cache, no-store`, in response to recording playback requests. When set to **Yes**, the ISR does not include the header. When set to **No**, the ISR does include the header.
8. **Internal API Authorization Type**—Select **token** to enforce authorized communication between the RSS components. Select **none** to disable authorization for RSS component communications. The default is **token**.
9. **Internal API Authorization Session Expires in**—Set the number of seconds before the authorization token expires and a new one is created. The default value is **3600** seconds.
10. Click **Update**.

13

Managing Template Definitions

ISR offers the FACE API for customers wishing to connect to ISR to extract recordings for use in other 3rd party or homegrown applications. Some legacy recording vendors require recording metadata be delivered in a pre-defined format. Using Export Templates, customers can create a defined format for data extraction and then call the FACE API, referencing the Template, to extract recording information in the defined format. Export Templates are version controlled and can be updated or replaced as needed. ISR provides the Verint® Import Manager Template, by default.

Template Definitions

Templates can be defined to format the metadata returned by FACE requests for segment details. They can be created, edited, and deleted in the Template Definitions sections of the Admin tab. Users can specify a name for the Template, and a version number is automatically assigned, starting at 1 and incrementing for each update to the Template body with the same name. In the case that a template body is changed to already existing content, an error is displayed stating that the same template body exists for the given version.



Note:

Templates continue to support legacy recordings that contain a single segment.

Formatting

The text contained in the Template body is returned as is, unless it is surrounded by percent symbols (%). When FACE is using a template and comes across a % character, if the next character is also a %, a single % is inserted in the response. Otherwise, it searches for a second % and tries to find a matching Field Parameter for the text between the %s (exclusive). If found, the segment's appropriate value for the Field Parameter Name is inserted in the response. If no default Field Parameter match is found, the Custom Data for the recording is checked, whereupon the value of a matching Custom Data field is appended to the response. In the event that no value can be determined for the given Field Parameter (in both the default list and among the Custom Data), an empty string is inserted in the formatted text returned to the client. If no closing % is found after an opening %, an error code/response is returned, indicating that the template is improperly formatted. Text between and after field parameters (delineated by %) is appended to the response as is.

Field Parameters

The following list contains the currently supported Field parameters with a brief description of each. In addition, any defined Custom Data fields can be included as Field Parameters using the Custom Data field name in the template body (surrounded by percent % signs).

- recordingId—recording ID

- filename—audio recording filename
- directory—audio recording file relative directory
- isrUcid—ISR UCID
- ingressCallId—ingress call ID
- egressCallId—egress call ID
- from—from/ANI
- to—to/DNIS
- accountId—account ID
- routeId—route ID
- rssId—RSS ID
- agentId—agent ID
- duration—duration (milliseconds)
- durationSeconds—duration (seconds)
- startDate—start date (yyyy-MM-dd)
- startTime—start time (HH:mm:ss)
- startDateUtc—start date in UTC (yyyy-MM-dd)
- startTimeUtc—start time in UTC (HH:mm:ss)
- startYear—start date year
- startYearUtc—start date year in UTC
- startMonth—start date month
- startMonthUtc—start date month in UTC
- startDay—start date day
- startDayUtc—start date day in UTC
- startHour—start time hour
- startHourUtc—start time hour in UTC
- startMinute—start time minute
- startMinuteUtc—start time minute in UTC
- startSecond—start time second
- startSecondUtc—start time second in UTC
- startMillisecond—start time millisecond
- startMillisecondUtc—start time millisecond in UTC
- startTimeZone—start time time zone (e.g. EDT)
- startTimeZoneOffse— start time time zone offset (e.g. +0400)
- pauseLength—pause length (milliseconds)
- baseUrl base—URL (from which recording file is served)
- sourceDirectory—archiver source directory
- destinationDirectory—archiver destination directory

- segmentId—segment ID
- checksum—checksum (MD5)
- endDate—end date (yyyy-MM-dd)
- endTime—end time (HH:mm:ss)
- endYear—end year date
- endMonth—end month date
- endDay—end date day
- endHour—end time hour
- endMinute—end time minute
- endSecond—end time second
- endMillisecond—end time millisecond
- endTimeZone—end time zone (for example, EDT)
- endTimeZoneOffset—end time zone offset (for example, +0400)
- endDateUtc—end date in UTC (yyyy-MM-dd)
- endTimeUtc—end time in UTC (HH:mm:ss)
- endYearUtc—end date year in UTC
- endMonthUtc—end date month in UTC
- endDayUtc—end date day in UTC
- endHourUtc—end time hour in UTC
- endMinuteUtc—end time minute in UTC
- endSecondUtc—end time second in UTC
- endMillisecondUtc—end time millisecond in UTC

Adding a New Template

You can create a special formatting template by performing the following procedure on the Dashboard:

1. In the Admin tab, click **Template Definitions**.
2. Click on the provided "verint" template for an example and return to "Template Definitions" when ready.
3. Click **Create**.

Template Definitions

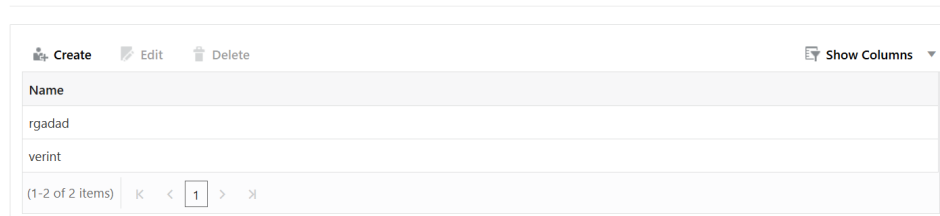

4. Assign a **Name**.

 **Note:**

While editing an existing template, the **Name** field is disabled. In the case that the same body exists for the template, the following error is displayed:

```
Template with same body and name already exists in the
system, for following
versions.
```

5. In the **Body** field, enter any required special formatting characters and the %-surrounded ISR fields represented in "Field Parameters".
6. Click **Create**.

 **Note:**

You may download segment metadata in the new special format using the example provided in "Common FACE Commands" in the *Oracle Communications Interactive Session Recorder API Guide*.

Recordings with No Media

ISR offers the ability to optionally write an empty (0 byte) file when a recording INVITE is received and indexed, but results in no RTP being received. These "missing" recordings can occur when a session terminates so quickly that the Recorder process does not have time to fully initialize, or when media is never offered for an established session.

To better reconcile these situations for certain customer use cases, the ISR ensures a recorded file is created and associated with the existing metadata regardless of whether RTP was ever received.

To enable this functionality, set the **Create Empty Recordings** parameter to **yes** for each Location instance. By default, this parameter is disabled.



Locations

← Back
Edit Location

← Previous
1
2
3
4
5
Next >

Location Configuration
Local/Mount Configurations
SFTP Configurations
Advanced Configurations
Conversion Configurations

Global? (Accessible to all Sites)	No
Checksum	None
Able to Delete Recordings	No
Store in Date Directory	Yes
Store in Account Directory	No
Purge Index of Missing Recordings	No
Create Empty Recordings	No

When this parameter is enabled, when a missing file for a recording record is encountered, the Archival process writes an empty file in the recording destination Location and logs a message similar to the following example:

```
9/7/17 14:20:00[INFO ]      Thread[ArchiverThread-71,5,main] (Missing File)
creating empty recording for /opt/isr/Recordings/
rss_g711_ulaw-1-2171@10.10.248.128.wav
```

This message can also be found in the **Recording Details, Segment Details, File Location** section of the Dashboard.

File Location	
Directory	/2019-06-20/09/23
Archival Status	Successfully Archived
Archival Remarks	Recording was archived by archiver ID 2 process ID localhost.localdomain16b992d92b2 at Thu Jun 27 09:43:49 EDT 2019

Existing customers who do not wish to change the current ISR behavior should leave the **Create Empty Recordings** parameter set to **No**.

14

Viewing Live Sessions

This chapter describes how to view active call sessions on the ISR, and whether or not the RSS is recording those sessions.

Manage Live Sessions

Use the **Live Sessions** link on the Admin page of the ISR Dashboard to view live call sessions currently occurring.



Note:

Only Super Users and Account Administrators can view live call sessions currently being received by an RSS.

Lives Sessions Page

From	To	Start Time	Status	Recorder
AP	rss	2021-01-08T10:08:45.646+00:00	Recording	rec59
AP	rss	2021-01-08T10:08:44.175+00:00	Recording	rec59
AP	rss	2021-01-08T10:08:42.990+00:00	Recording	rec59



Note:

Refresh button fetches latest live recordings at a given point in time.

The following table describes the information displayed on the Live Sessions page.

Column Heading	Description
From	Specifies the From SIP URI. This is the URI from where the call session is coming.
To	Specifies the To SIP URI. This is the URI to where the call session is destined.
Start Time	Specifies the date and time in the user's preferred time zone locale when the active session began.

Column Heading	Description
Status	Identifies whether the session is: Recording - Call session is in progress and the RSS is recording the session. Idle - Call session is in progress but the RSS is not currently recording the session.
Recorder	Specifies the name of the RSS receiving the live call session.

The Live Sessions page allows you to view all active call sessions currently coming into the RSS, and whether or not the call session is being recorded by the RSS.

If a session is recording, a **Recording** status displays in the Status column. If the RSS is not currently recording the session, the status displays as **Idle**.

Up to 15 active call sessions display on a single page. The total number of active call sessions display at the bottom of each page.

If more than 15 calls display on a single page, click the **Next** and **Previous** links to navigate between pages of the Live Sessions list.

15

Managing Sites

This chapter describes how to configure, manage, and monitor the components of an ISR Site. Site components can include the RSS (recording server), RSS locations, Archivers, Session Agents, and Web Appliances. Each of these components can be accessed from the Sites page under the Administrator menu.

Manage Sites

Using the **Sites** link on the Admin page of the ISR Dashboard, you can manage ISR sites in your network. A site is a physical location, a group of recording servers, or a single ISR.

From the Admin page, click Sites to view the sites configured on the ISR.

Sites

Name	Recorders	Locations	Archivers
docs	Recorders (0) Running: 0 Running with Errors: 0 Offline: 0 Current Sessions in Use: 0 Total Sessions Capacity: 0	Locations (0)	Archivers (0) Enabled (0) Disabled (0)



Note:

Only Super Users have access to managing sites. Account Administrators can view the site configurations but do not have access to managing the information.

Managing sites includes adding, editing, and deleting sites that contain configurations for the following components:

Site Item	Description
Name	Name of the managed site.
Recorders	Allows you to view RSS (recording server) information, delete an RSS, modify an RSS, or add a new RSS associated with a site. The configuration parameters include the RSS name, IP Address, XML-RPC port number, and utilization of available ports for each RSS.
Locations	Allows you to edit or delete information about the current Location of the RSS, or add a new Location for the RSS associated with a site. The configuration parameters include Location name, the source directory path on the RSS (where recordings are stored), the HTTP URL path to the recordings, and the amount of free space on the RSS in Kilobytes and Percentage.

Site Item	Description
Archivers	Allows you to edit or delete information about an Archiver(s), or add a new Archiver to a site. An Archiver can move recording files from a single location to one location only. However, you can configure multiple archivers to each move files to corresponding destination locations. The configuration parameters include the Archiver's IP address, the source from which to get the recordings, the destination for which to send the recordings, Archiver threads, number of move attempts, the mode of the archiver (primary or failover), and the state of the archiver (active or paused).

To manage the components of a site, select a site from the Sites page and click **Manage Site**.

Recorders

Name	VoIP IP	Status	Uptime	Current Sessions in Use	Session Capacity
East_rec	100.1.1.10	!	N/A	0	2
East_rec2	200.1.1.10	!	N/A	0	2

(1-2 of 2 items) < 1 >

Adding a Site

Superusers can add a Site to the ISR using the **New Site** link on the Sites page. Once the Site is created and saved to the ISR database, configure the following applicable components for the Site:

- RSS (required)
- RSS Location (required)
- Archiver (optional)
- Session Agent (optional)
- Web Appliance (optional)

To add a site:

1. After logging into the ISR Dashboard, click **Admin** in the main menu (or **Edit System Configurations** on the Home page).
2. Click **Sites**. The Sites page displays.

Sites

Name	Recorders	Locations	Archivers
docs	Recorders (0) Running: 0 Running with Errors: 0 Offline: 0 Current Sessions in Use: 0 Total Sessions Capacity: 0	Locations (0)	Archivers (0) Enabled (0) Disabled (0)

3. Click the **Create** link in the upper right corner of the page. The Create Site page displays.
4. **Name**—Enter a name for the Site.
5. Click **Create**. The Site name displays on the Sites page.

Once you add the Site, you must configure the RSS and the RSS Location. You can also configure a Session Agent and Web Appliance if required. The following paragraphs describe how to configure each of these elements.

Managing an RSS

After adding a Site to the ISR database, you must add an RSS to the Site configuration. The RSS configuration is the recording server information required for the Site's ISR. You can add, edit, and delete RSSs from the ISR database.





Note:

Oracle recommends you contact your Technical Support representative before adding or changing an RSS configuration.

Sites Recorders Page

The Recorders Listing page contains the following information:

RSS Information	Description
Name	RSS name
VoIP IP	RSS Voice network IP address
Status	<ul style="list-style-type: none"> •  - Running •  - Offline •  - Running with errors
Uptime	Number of Days RSS has been available
Current Sessions In Use	Number of active sessions
Sessions Capacity	Total number of simultaneous sessions allowed

Adding an RSS

After adding a Site to the ISR, you must add an RSS to the Site's configuration.

To add an RSS to a Site:

1. From the Sites page, select a Site and click **Manage Site**.

The Recorders page displays by default.

2. Click **Create**. The Create Recorder page displays.
3. **Name**—Enter a name that describes the RSS you are adding.
4. **VoIP IP**—The RSS Voice network IP address.

Note:

A new location is created for the RSS using this IP Address under the Location component, with a default path value of `opt/isr/Recordings`. You can edit the location if you've installed the RSS on a different filesystem path. For more information, see [Managing an RSS Location](#).

5. **Admin IP**—The IP address to connect to the RSS host over the "Admin" network.
6. **Data IP**—The IP address to connect to the RSS components (for example, the Converter, API, and Recorder processes) over the "Data" network.
7. **Sessions Capacity**—Total number of licensed ports on the RSSs on this Site.
8. Click **Create**. The new RSS displays on the RSS page.

Editing a Recorder

Once you have added a Recorder, you can edit the RSS parameters if required.

To configure a Recorder:

1. On the Sites page, select a Site with a Recorder configured and click **Manage Site**. The Recorders page displays.
2. Select a Recorder and click **Edit**. The Edit Recorder page displays, showing the recorder status.

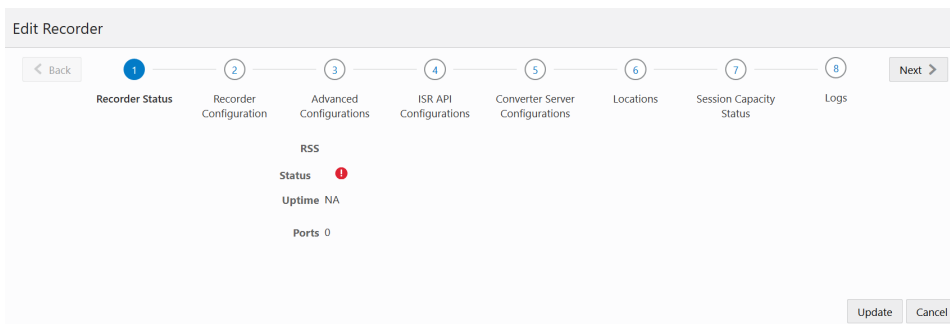

3. The following Recorder configuration sections are available:

Name	Description
Recorder Status	Provides information regarding the status of this Recorder including the RSS IP, run status, uptime, and sessions capacity.
Recorder Configuration	RSS Recorder process connection details
Advanced Configurations	Manages the Recorder's advanced configurations including recorder webservice, RTP, SIPREC, SIP, and logging.
ISR API Configurations	API connection settings
Converter Server Configurations	Converter process settings
Locations	Recorder process Location settings
Session Capacity Status	Displays the ISR's session capacity status.

4. When you are finished editing the RSS configuration, click **Update**. The changes are saved to the ISR database. The RSS page displays.

Recorder Status

When the Edit Recorder page displays, the default page is the Recorder Status. The Recorder Status displays the following information:

- RSS IP address
- Run Status
- Uptime
- Sessions Capacity

Recorder Configuration

The following fields may be changed in a Recorder's Recorder Configuration settings:

- **Name**—Enter a name that describes the RSS you are adding.
- **VoIP IP** —The RSS Voice network IP address.
- **Admin IP** —The IP address to connect to the RSS host over the "Admin" network.
- **Data IP**—The IP address to connect to the RSS components (for example, the Converter, API, and Recorder processes) over the "Data" network.
- **Session Capacity**— Total number of licensed ports on the RSSs on this Site.
- **Config Update Interval**—How often, in seconds, the Recorder attempts to update its configuration.

- **Suppress SIPREC Metadata Updates**—Enables and disables the reINVITE Suppression feature. When set to **Yes**, the ISR ignores SIPREC metadata updates with no new metadata values.
- **Suppress SIPREC Metadata Updates Ignore Tag**—Select whether to add SIPREC metadata tags whose changed values can be ignored when suppressing reINVITES.
- **Maintenance Mode**— Select **Yes** to force the RSS into "Maintenance Mode", an off-line state where recording records are not created in the Index but written locally to a file. You must restart the Recorder process for the setting to take effect. Any CDRs created when the ISR is in Maintenance Mode must later be manually imported to be properly indexed.

Recorder Advanced Configuration

By expanding the accordions on the Recorder's Advanced Configurations page, the following information may be configured:

- Recorder Webservice Configurations
- Recording configurations
- SIP configurations
- Logging configurations

Recorder Webservice Configurations

The following settings are available to configure by clicking on the Advanced Configuration page's **Recorder Webservice Configurations** accordion:

- **Webservice SSL Enabled?**—Enables the Recorder webservice for HTTPS communications. This is enabled by default.
- **Webservice SSL Certificate File**—The path of the file offered in the certificate exchange. The default value is `"/opt/isr/security/keys/rss_cert.pem"`.

Recording Configurations

The following setting is available to configure by clicking on the Advanced Configuration page's **Recording Configurations** accordion:

- **Segmentation State**—Specify whether recording segmentation is enabled for this recorder.

SIP Configurations

The following settings are available to configure by clicking on the Advanced Configuration page's **SIP Configurations** accordion:

- **SIP Authentication Password**—Enter the SIP authentication password.
- **SIP Authentication Realm**—Enter the SIP authentication realm
- **SIP Authentication User**—Enter the SIP authentication user.
- **SIP Comfort Noise**—Specify the type of SIP comfort noise to use. The following are valid values:
 - Negotiate
 - Force (default)

- Disabled
- **SIP Debug Log**—Enable or disable the SIP debug log.
- **SIP ISR UCID Header Field**—The administrator may set the SIP header name whose value is to be parsed as the ISR's UCID. The default value is "X-ISR-UCID".
- **SIP Percent To Record Rejection**—Enable or disable the SIP percent to record rejection functionality.
- **SIP Percent To Record Rejection Response Code**—Specify the SIP percent to record rejection response code.
- **SIP Percent To Record Rejection Response Message**—Specify the SIP percent to record rejection response message.
- **SIP Port**—Specify the SIP port number.
- **SIP Rejection Substitution Code**—Specify the SIP rejection substitution code.
- **SIP Route/Account Capacity Rejection Response Code**—Specify the SIP Route/Account capacity rejection response code.
- **SIP Route/Account Capacity Rejection Response Message**—Specify the SIP Route/Account capacity rejection response message.
- **SIP System Capacity Rejection Response Code**—Specify the SIP system capacity rejection response code.
- **SIP System Capacity Rejection Response Message**—Specify the SIP system capacity rejection response message.
- **SIP SSL Certificate File**—Enter the SIP SSL certificate file.
- **SIP Transport Method**—Specify the SIP transport method. The following are valid values:
 - UDP (default)
 - TCP
 - TLS

Logging Configurations

The following settings are available to configure by clicking on the Advanced Configuration page's **Logging Configurations** accordion:

- **Local CDR**—Enable or disable logging on the local CDR.

RSS API configurations

The following settings are available to configure the internal RSS API:

- **API URL Scheme**—The protocol used for the API URL. The default value is "https".
- **API URL Port**—The port number on which the API listens. The default value is "8443".
- **API URL Base Path**—The base path serving the API application. The default value is "/IsrApi/rest/".
- **API Cache Update Interval**—The number of seconds before the API cache is updated. The default value is "300".

RSS Converter Server Configurations

The following settings are available for configuring the Converter Process:

- **Codec map update interval**— The number of seconds between Codec Map updates of transmission and playable codecs. The default value is "300".
- **Config update interval**— The number of seconds before the Converter updates its broader configurations. The default value is "300".

 **Note:**

The remaining fields in the Converter Server Configurations section are not available for configuration.

RSS Locations

The following settings configure where the Recorder process writes its files:

- **Location**— The primary location for writing recorded files. The default value is "<RSS name (IP)> Primary".
- **Failover location**— The failover location for writing recorded files. The default value is "<RSS name (IP)> Secondary".

RSS Logs

The RSS's Logs section provides the most recent logs written by the Recorder process.

Deleting an RSS

You can delete an RSS from a Site if required.

To delete an RSS:

1. On the Sites page, select a Site with an RSS and click Manage Site. The Recorders page displays.
2. Select a Recorder and click Delete. The following prompt displays:
Are you sure you want to delete this RSS?
3. Click **Continue** to delete the RSS from the ISR database or click the **X** in the upper-right corner of the box to cancel the delete function.

 **Note:**

Once you delete an RSS, it cannot be recovered.

Managing an RSS Location

After adding an RSS to the ISR, the Location is automatically assigned (see Adding an RSS). The **Location** indicates the specific location in the ISR system where the recordings are stored. You can add a new Location or change an existing Location if required. You can also delete the location if necessary.



Note:

When you add your first RSS, the ISR automatically adds an **RSS Primary Location** to the **Locations** page.

Adding a Location

You can add a new Location for an RSS if required.



Note:

A single configured Archiver can move recordings to only one destination location. If you need recordings to go to other destination locations, you must configure an Archiver for each of those locations. For more information about configuring an Archiver, see Managing Archivers.

To add a new RSS Location:

1. From the Sites page, select a Site and click **Manage Site**. The Recorders page displays.
2. Click the **Location** link. The following table describes the information displayed on the Location page.

Column	Description
Name	Name of the RSS Location.
Local Recordings Directory	Specifies the directory path associated with the Location.
Remote Access URL	Specifies the Web URL path for accessing the recordings via a browser.
Disk Usage	If applicable, provides information about disk usage for this location.

3. Click **Create**. The Create Location page displays.

Locations

4. **Name**—Enter a name that describes the Location you are adding. For example, RSS1 (1.1.1.1) Primary.
5. **Remote Access URL**—Enter the URL that identifies the Web location for accessing the recordings via a browser. For example, `http://location1.foo.com/Recordings`.

Note:

Locations created automatically by the addition of a valid RSS configure the URL and serve recordings from it. If you add custom locations, you must configure them to be served by a web server and then set this URL if you want them to be playable via the Dashboard or APIs.

6. **Access Type**—Select one of the following:
 - Local - Local disk
 - Mount - NFS Mount shared directory
 - SFTP - SFTP server
 - SFTP Port - Specify the port number. Valid values are 0 - 65535. The port needs to be enabled in the specified host.

The following sections describe the additional configuration parameters available in the Location page's section. When you are finished configuring all of the parameters for your environment, click **Create** to complete creating the Location.

Local/Mount Configurations - Local Recordings Directory

The Local/Mount Configurations according allows you to specify the directory of the Account's Archival destination Location.

- **Local Recordings Directory**—Specifies the directory path to where the Archiver stores the recordings on the RSS associated with the Location. For example, `/opt/isr/Recordings`.

Note:

When **Access Type** is set to **SFTP**, the Archiver attempts to move the Account's recordings to the SFTP user "home" path on the SFTP server.

SFTP Configurations

The SFTP configuration section allows you to configure the Location's SFTP properties.

- SFTP Host—Specify the Location's SFTP host.
- SFTP User—Specify the Location's SFTP user.
- SFTP Password—Specify the Location's SFTP password.

Advanced Configurations

The Advanced Configurations section allows you to configure several advanced configuration properties for the Location.

- Global? (Accessible to all Sites)—Select whether or not this Location may be used in Archival configurations on all Sites. Valid Values are:
 - Yes - This Location may be used in all Sites.
 - No (default) - This Location configuration may apply to this Site only.
- Checksum—Enables the MD5 Hash for Recordings feature. For more information, see "Configuring MD5 Checksum Validation".
- Able to Delete Recordings—Select whether or not this Archiver has permission to delete recordings and metadata stored longer than specified in Route and Account configurations. Valid values are:
 - Yes (default) - Archiver deletes files older than specified in Route and Account configurations.
 - No - Archiver does not delete files, regardless of the date specified in the Route and Account configurations.
- Store in Date Directory—Select whether or not the Archiver stores the recording files in a folder identified by the current date. Valid values are:
 - Yes (default) - Archiver stores recordings in a folder by date.
 - No - Archiver does not store recordings in a folder by date.
- Store in Account Directory—Select whether or not the Archiver stores the recording files in a folder identified by the associated account. Valid values are:
 - Yes - Archiver stores recordings in a folder by account.
 - No (default) - Archiver does not store recordings in a folder by account.
- Purge Index of Missing Recordings—Select whether or not the Archiver removes recording entries containing no recorded media files, from the main recording table, and sends them to a different "problem" table that can be reviewed at a later time. By enabling this feature, you prevent a user from viewing recording files with no recorded media files when they perform a search. However, an Administrator can view the "problem" table if required, for troubleshooting purposes. When this field is disabled, the Archiver keeps the recording file with no recorded media in the main recording table. Valid values are:
 - Yes - Archiver moves recordings containing no recorded media from the main recording table to a "problem" table. Users cannot view these recordings, but Administrators may view the "problem" table.
 - No (default) - Archiver keeps recordings with no recorded media files in the main recording table. Users may view these recordings.

- Create Empty Recordings—When enabled, the Archiver creates a recorded file even when no media was available for writing (for example, a session terminates immediately after INVITE is negotiated). Valid values are:
 - Yes - Archiver creates an empty recorded file when media is not available for writing.
 - No (default) - No empty recorded files are created.

Conversion Configurations

Configure how and when the Archiver converts RPDD recording files to .wav files prior to moving them to their destination location via the Conversion Configurations section.

- **Converter IP Address**—Enter the IP address (in dotted decimal format) of the media converter (RMC). For example, 172.53.45.6.

 **Note:**

For more information on managing the media converter, see "ISR RMD".

- **Converter REST Webservice SSL Enabled?**—Enables or disables secure communications with the Converter process webserver. The default is "Yes".
- **Mode**—Select whether all RPDD recordings (currently G.729 recordings or recordings from routes set to **Always record as raw RTP**) are converted, a percentage of recordings are converted, or no recordings are converted when the Archiver moves them to the destination location.
 - Disabled (default) - The RMC does not convert RPDD recordings from .rpdd format to .wav format.
 - Convert All - The RMC converts all RPDD recordings from .rpdd format to .wav format
 - Convert by Percentage - The RMC converts only a percentage of all RPDD recordings from .rpdd format to .wav format, based on the value entered for the **Percent of Recordings to Convert** parameter.
- **Percent of Recordings to Convert** - Select a number to indicate the percentage of recordings to be converted by the RMC. The **Mode** field must be set to **Convert by Percentage** in order to set the percentage value. Valid values are 0 to 100. Default is 100 percent.

Editing a Location

You can edit an existing Location if required.

To edit a Location:

1. On the Sites page, select a Site with a Location and click Manage Site. The Recorders page displays.
2. Click the **Locations** link. The Locations page displays.
3. Select a Location and click **Edit**. The Edit Location page displays.
4. Edit the parameters for the RSS Location as applicable using the procedures defined in "Adding a Location".

5. When you are finished editing the RSS Location, click **Update**. The changes are saved to the ISR database and display on the Locations page.

Deleting a Location

You can delete a Location if required.

To delete a Location:

1. On the Sites page, select a Site with a Location and click **Manage Site**. The Recorders page displays.
2. Click the **Locations** link. The Locations page displays.
3. Select a Location and click **Delete**. A prompt asking, "Are you sure you want to delete this Location?" displays.
4. Click **Continue** to delete the Location from the ISR database or click the **X** in the upper-right corner of the box to cancel the delete function.

 **Note:**

Once you delete a Location, it cannot be recovered.

Managing Archivers

You configure an Archiver(s) to store recordings. The Archiver(s) moves recording files from one Location to another Location, often from a local disk to a Network Attached Storage (NAS) or a Storage Area Network (SAN). It is important to consider your archival requirements before assigning servers to sites, as Archivers are ISR-specific.

When you first install the ISR, you specify a Primary location for where recordings are written in real time. This can be a partition on the ISR server (RSS) or on another drive or server on the network. (The primary source location in the illustration below is `/opt/isr/Recordings` on the RSS).

You can also specify a secondary (failover) source location for the recordings. In the event that the primary location is inaccessible (i.e., it is full, or it can't be reached on the network, etc.), the ISR begins writing the recordings to the secondary location in real time. (The secondary source location in the illustration below is `/opt/isr/ArchivedRecordings`).

 **Note:**

Oracle recommends that you specify a secondary location for your recordings in the event the primary is inaccessible for any reason. For more information about setting up your secondary (failover) location, see the Interactive Session Recorder Installation Guide.

For ISR installations that do not require large capacity storage spaces for recordings, the primary and secondary locations may provide sufficient space to store the recordings. However, for installations that may have a very large quantity of recordings, additional storage devices such as a Network-Attached Storage (NAS) or a Storage Area Network

(SAN), may be required to off-load the recordings from the ISR, to a more permanent location on the NAS or SAN.

On the ISR, you can configure a Primary and Secondary (Failover) Archiver to move recordings from the primary and secondary locations, to more permanent storage devices as required. The Primary Archiver moves recordings from the primary location (source location) to the NAS or (destination location). The Secondary or Failover Archiver moves recordings from the secondary location (source location) to the NAS or (destination location). Since the recordings in the secondary location are flagged as being stored in this location, the Failover Archiver looks for these flagged recordings and moves them to the more permanent storage location.

The following illustration shows the use of the Primary and Failover Archiver in a network.

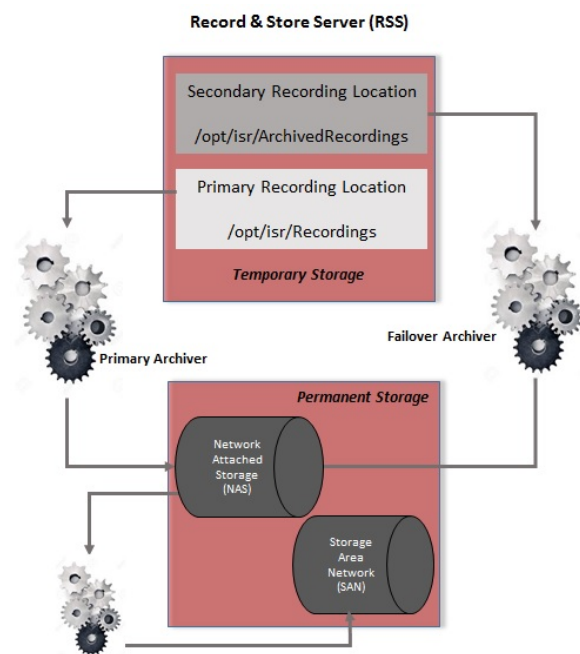

A single configured Archiver can move recordings to only one destination location. If you need recordings to go to other destination locations, you must configure an Archiver for each of those locations.

The **Archivers** box on the Sites page displays the current status of any Archivers for the site.

Using the Dashboard, you can add a new Archiver to the site, edit the configuration of an existing Archiver, or delete an Archiver if required.

Adding an Archiver

You can add an Archiver to a Site if required.

 **Note:**

You may also configure Archiving on a per Account basis. For more information, see "Archival" in the "Managing Accounts" chapter.

To add an Archiver:

1. From the Sites page, select a Site and click **Manage Site**.
2. Click **Archivers**. The Archivers page displays.

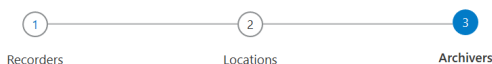



Archivers

IP Address	Source	Destination	Status	Mode
172.30.12.103	undefined	rss197 (10.10.248.197) Secondary	Enabled	Primary

(1 of 1 items) | K < 1 > »

The following table describes information displayed on the Archivers page.

Column	Description
IP Address	IP Address of the Archiver. Note: Archiver resides on the RSS.
Source	Specifies the location where the source recordings reside. This is the location from where the Archiver gets the recordings. For a Primary Archiver, the value for this field should be the Primary Source Location. For a Failover Archiver, the value should be the Secondary Source Location.
Destination	Specifies the location of the storage devices (NAS, SAN, etc.) to which the Archiver moves the recordings for storage. When the Archiver moves the recording files to the destination location, it can create subdirectories in this path to sort by account, date, and time.
Status	Identifies whether the Archiver is enabled (active) for moving recording files, or temporarily disabled (paused). Status can be:  Enabled  Disabled
Mode	Specifies the whether this Archiver is the Primary or the Failover Archiver. The Primary Archiver moves all recordings from the Primary Source Location to the destination location. The Failover Archiver moves all recordings from the Secondary Source Location to the destination location.

3. Click **Create**. The new Archivers dialog box displays.
4. **IP Address**—Enter the IP address of the Archiver you are adding to this site. Valid values are IPv4 addresses entered in the format 0.0.0.0. (for example, 134.35.43.56).

5. **Source**—Select the location where the source recordings reside. This is the location from where the Archiver gets the recordings. For a Primary Archiver, the value for this field should be the Primary Source Location. For a Failover Archiver, the value should be the Secondary Source Location.

 **Note:**

The Primary Source Location and Secondary Source Location were configured during the ISR installation. For more information, see the Interactive Session Recorder Installation Guide.

6. **Destination**—Select the location of the storage devices (NAS, SAN, etc.) to which the Archiver moves the recordings for storage.
7. **Number of Threads**—Select the number of simultaneous recordings that an Archiver can move at one time. Valid values are **1** through **90**. Default is **3**.
8. **Move Attempts**—Select the number of attempts that the Archiver makes when moving recordings from the source location to the destination location. If the Archiver fails to move the recording files the first time, it repeats the attempts to move the files the number of times you set for this field. Valid values for this field are **1** through **10**. Default is **1**.
9. **Mode**—Select whether this Archiver is the Primary or the Failover Archiver. The Primary Archiver moves all recordings from the Primary Source Location to the destination location. The Failover Archiver moves all recordings from the Secondary Source Location to the destination location. Valid values are:
 - **Primary** (default) - This Archiver moves files from Primary Source Location.
 - **Failover** - This Archiver moves files from Secondary Source Location.
10. **Status**—Select whether the Archiver is enabled (active) for moving recording files, or temporarily disabled (paused). Valid values are:
 - **Enabled** (default) - Archiver is active and monitors when recording files are ready to be archived.
 - **Disabled** - Archiver is temporarily disabled and does not move recording files.
11. Click **Create**. The new Archiver displays on the Archivers page.

Editing an Archiver

You can edit an Archiver configuration if required.

To edit an Archiver:

1. From the Sites page, select a Site with an Archiver and click **Manage Site**.
2. Click **Archivers**. The Archivers page displays.
3. Select an Archiver and click **Edit**. The Archivers page displays.
4. Edit the parameters for the Archiver as applicable using the procedures defined in "Adding an Archiver".
5. When you are finished editing the Archiver, click **Update**. The changes are saved to the ISR database and display on the Archivers page.

Deleting an Archiver

You can delete an Archiver if required.

To delete an Archiver:

1. On the Sites page, select a Site with an Archiver and click **Manage Site**.
2. Click **Archivers**. The Archivers page displays.
3. Select an Archiver and click **Delete**. You are prompted to confirm the delete.
4. Click **Continue** to delete the Archiver from the ISR database or click the **X** in the upper-right corner of the box to cancel the delete function.

 **Note:**

Once you delete an Archiver, it cannot be recovered.

16

Managing Recordings

This chapter provides information about managing account recordings on the ISR. You can play, view, edit, download, and delete recordings as required.

Manage Recordings

All user levels can be configured to view, edit, delete, download, and/or play recordings stored on the ISR (or other configured storage facility). However, a Tenant Administrator and Tenant User, if granted the appropriate permissions, can edit, play, download, and delete their own recordings only.



Note:

Recordings that display are dependent on the level of user currently logged into the ISR Dashboard.

In addition to viewing, editing, playing, downloading, and deleting recordings, a user with Notes and Scoring permission can also specify notes for a recording, and specify a rate or score for a recording. A recording can be rated or scored from 1 star to 5 stars, with 5 stars being the best. For more information about assigning a score to a recording see Recording Details.

Access the Recordings from the Home page by clicking **Recordings**.

Each recording displays on the Recordings page with information about that recording.

Recordings Page

RSS Ingress Call ID	Start Time	From	To	Duration
00E1C387-8787-E911-903D-2F98017E1DCD@10.191.45.119	2019-06-07 05:51:08 AM	SIPPER	RS522	10 seconds
1-1751@10.178.248.32	2019-06-07 05:50:38 AM	7777	5555	10 seconds
1-1749@10.178.248.32	2019-06-07 05:50:22 AM	7777	5555	10 seconds
00F82452-8787-E911-903F-2F98017E1DCD@10.191.45.119	2019-06-07 05:49:38 AM	SIPPER	RS522	11 seconds

The following table describes each possible column on the Recordings page.

Column Heading	Description
Start Time	Specifies the start date and time of the recording. This column is based on the User's preferred time zone locale.
From	Specifies the calling party.
To	Specifies the called party.
RSS Ingress Call ID	Specifies the call-id from the SIP headers of the initial INVITE.

Column Heading	Description
RSS Egress Call ID	Specifies the call-id from the SIP header of a secondary call leg. Only applicable for pass-through or Record & Save routes.
Duration	Specifies the length of time, in seconds, of the recording.
Session ID	Specifies the unique X-ISR-UCID for this recording.

Playing a Recording

After a recording occurs on the ISR, it is saved as an audio, and optionally video, file so a user can review the details of the recording and playback the audio and video. Play a recording by first choosing it in search results or the default listing to bring up the Recording Details page, then clicking the Segment tab and the play button for that recorded Segment file.



Note:

The recording's metadata is saved in the ISR database.

The Recordings page displays all up-to-date recordings that meet the search parameters and access level restrictions of the user. Depending on the size of your storage device (Network Attached Storage (NAS), Storage Area Network (SAN)), older recordings may not be stored locally. However, this is transparent to the user viewing the recordings. Regardless of where the recordings are stored, all recordings display on the Recordings page.

Before playing recordings, make sure you have a media application that plays audio files with a .wav format. For more information about the software requirements and recommendations for playing recordings, see Requirements/Recommendations.

To play a recording:

1. After logging into the ISR Dashboard, click **Recordings** on the Home Page. The Recordings page displays.
2. Select a recording and click **Details**. The Recording Details page displays.
3. Click the **Segment 1** tab. If you have the appropriate permissions, you may play the recording using the play button at the top of the screen.

Recording	Segment 1			
Account	System	Duration	10 seconds	Delete Update
Session ID	x-isr-ucid-5-28883@10.178.248.32	Time	2019-06-20 05:23:04 AM	
From	7777			
To	6666			
▶ Details				
▶ Notes And Scoring				
▶ File Location				
▶ Custom Data Fields				

 **Note:**

To find a specific recording, perform a search using the **Advanced Search** link in the upper-right corner of the page. For more information, see "Search Tools". The Recordings page refreshes depending on the value set in **Settings, Refresh Rate (seconds)**. Default is every 30 seconds. For more information about setting the Refresh rate, see "Dashboard Settings". When the recording is retrieved, the file(s) automatically opens using the applicable media application installed on your computer. For media applications you can use, see "Requirements/Recommendations".

Viewing and Editing Details of a Recording

The ISR Dashboard allows you to view and edit specific details and metadata of a recording if required. From a Recording's Details page, you can:

- Play a recording.
- Assign custom data fields to a recording.
- Specify whether or not the recording is completed.
- Assign a length of time, in hours/minutes that the reviewer spent reviewing/transcribing the recording.
- Specify notes pertaining to the recording.
- Assign a rating to the recording.
- Create a category for which to place the recording.
- Transcribe the conversation that took place on the recording.

To play a recording from the details page:

1. After logging into the ISR Dashboard, click **Recordings**.
The Recordings page displays.
2. Select a recording and click **Details**. The following Recording Details page displays.

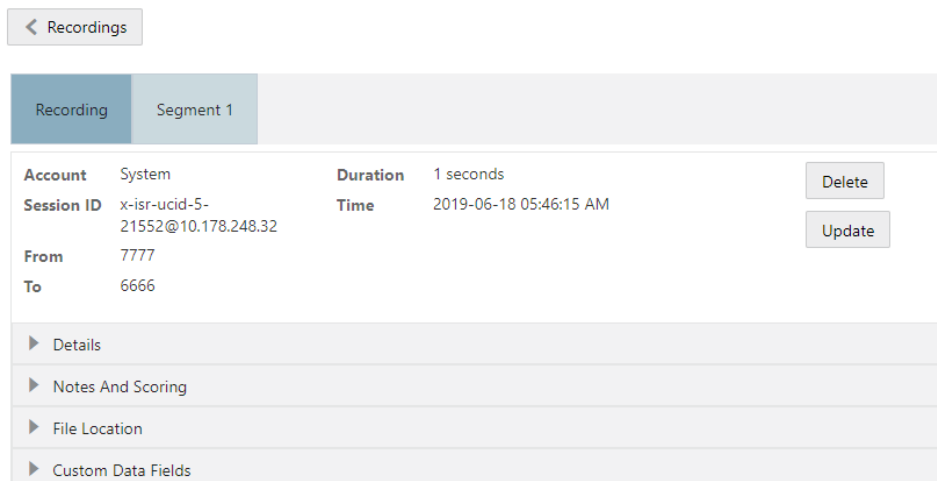

Recording		Segment 1	
Account	System	Duration	1 seconds
Session ID	x-isr-ucid-5-21552@10.178.248.32	Time	2019-06-18 05:46:15 AM
From	7777		
To	6666		
<input type="button" value="Delete"/>			
<input type="button" value="Update"/>			
▶ Details			
▶ Notes And Scoring			
▶ File Location			
▶ Custom Data Fields			

The following table describes information displayed on the Recording Details page.

Column Heading	Description
Account	Specifies the Account name associated with the recording.
Session ID	The unique session identifier for the session that contains the recording segment(s).
From	Specifies the calling party.
To	Specifies the called party.
Duration	Specifies the length of time, in seconds, of the recording.
Time	Specifies the date and time when the active session began. This is displayed in the user's preferred time zone locale.

To play the recording, click the appropriate segment tab. For example, Segment 1 and the play button at the top of the segment details.

When the recording is retrieved, the file(s) automatically opens using the applicable media application installed on your computer. For media applications you can use, see "Requirements/Recommendations".

You can display additional recording details, session metadata, and session participant metadata if required. Refer to the following paragraphs for more information.

Viewing Recording Details

To display details:

- On the Recordings page, choose a recording and click **Details**. The Recording Details page displays.

The screenshot shows a user interface for viewing recording details. At the top, there is a breadcrumb navigation with a back arrow and the text 'Recordings'. Below this, there are two tabs: 'Recording' (which is active) and 'Segment 1'. The main content area displays the following information:

Account	System	Duration	1 seconds	<input type="button" value="Delete"/>
Session ID	x-isr-ucid-5-21552@10.178.248.32	Time	2019-06-18 05:46:15 AM	
From	7777			
To	6666			

Below the recording details, there are four expandable sections, each with a right-pointing arrow:

- ▶ Details
- ▶ Notes And Scoring
- ▶ File Location
- ▶ Custom Data Fields

Viewing Recording Details Recorder and RSS Information

To view Recording Details recorder and RSS information:

1. On the Recordings page, choose a recording and click **Details**. The Recording Details page displays.
2. Click **Details**.
 - Recorder: Indicates the RSS that received the call session for the recording.

- **RSS Ingress Call ID:** Indicates the call-id received in the header of the initial SIP INVITE.

Notes and Scoring

You can include transaction notes and ratings for a recording by selecting **Notes and Scoring** from the Recordings page.

The following information displays.

1. **Complete**—Select whether or not the call session represents a completed transaction for this recording. For example, if a caller calls into a Technical Support Center for problems with his PC, the call is recorded. If the problem was not resolved on the initial call session, the reviewer can select No for the Complete Transaction field, indicating that the problem was not resolved on this call. Valid values are:
 - No (default) - The transaction occurring during this recording is not yet complete.
 - Yes - The transaction occurring during this recording is complete.

 **Note:**

The Complete Transaction field must be enabled for editing. For more information about enabling this field for editing, see Recording, Editing Permissions.

2. **Hours**—Enter the length of time, in hours that the reviewer spent reviewing/transcribing the recording. Valid values are in decimal format using numeric characters. For example, 6.5, where 6 indicates the hours and .5 indicates 1/2 hour.
3. **Rating**—Click on a star to rate the recording. This is a score that you can assign to this recording based on a level from 1 star to 5 stars, with 1 being the worst rating, and 5 being the best rating. When all stars are blank, no rating is assigned to the recording.

 **Note:**

The Rating field must be enabled for editing. For more information about enabling this field for editing, see Recording, Editing Permissions.

4. **Notes**—Enter notes pertaining to the current recording. Adding more than will fit in this box displays scroll bars in the window that allow you to scroll through multiple screens of the note.

 **Note:**

The **Notes** field must be enabled for editing. For more information about enabling this field for editing, see "Recording Editing Permissions". Enabling the **Notes** field automatically enables the **Transcription** field.

5. **Transcription**—Enter the conversation that took place during the current recording. Adding more characters than will fit in this box displays scroll bars in the window that allow you to scroll through multiple screens of the transcription.
6. **Category**—Enter a category name to associate with the recording, and press <Tab>.

A category bubble displays in the Category field. This feature provides easy recording searches based on category rather than individual recordings.

To create additional categories to associate with the current recording, repeat Step 4.

- Click **Update** to save the details for the recording.

Note:

The above agent-focused fields are available through Dashboard and FACE at the overall session level, but not for individual Segments in the session. These fields are replaced with a much more flexible workflow using Custom Data in Segments and soon deprecated for overall session-level details as well.

Recording Details File Location

The File Location section on the Recording Details page provides information about storing a recording indefinitely.

File Location	
Directory	/2019-06-20/09/23
Archival Status	Successfully Archived
Archival Remarks	Recording was archived by archiver ID 2 process ID localhost.localdomain16b992d92b2 at Thu Jun 27 09:43:49 EDT 2019

Recording Details Custom Data

Specifies custom data values to associate with this recording. This information is specific to this recording

Create custom data fields via the Admin page's **Custom Data Fields** link. For more information on configuring Custom Data, see "Custom Data".

Custom Data Fields	
 Add  Edit  Delete	
Name	Value
samplefield1	To
samplefield2	From
Page 1 of 1 (1-2 of 2 items)  < 1 > 	

Note:

To add or change detailed information about a recording, the user must have permission privileges for the Account's route associated with the recording. To provide permission to add Custom Data Fields, see "Custom Data".

Segment Details Configuration

To display and specify Segment details:

1. On the Recordings page, choose a recording and click **Details**. The Recording Details page displays.
2. Click the **Segment #** tab and the Segment details display.

The screenshot shows the 'Recording Details' page for 'Segment 1'. At the top, there are two tabs: 'Recording' and 'Segment 1', with 'Segment 1' being the active tab. Below the tabs is a media player interface with a play button, a volume icon, and a progress bar showing '0:00/0:01'. Below the media player, there is a table of metadata:

File Name	rss_sd_siprec -2-26017@10.178.248.32.wav	Start Time	2019-06-28 04:57:22 AM	Download
Duration	1 seconds	End Time	2019-06-28 04:57:23 AM	
Secured Media	No Secured Media			

Below the metadata table, there is a list of expandable sections:

- ▶ Details
- ▶ File Location
- ▶ Custom Data Fields
- ▶ Session Metadata
- ▶ Session Participant Metadata
- ▶ DTMF Events

Segment Recording Details Custom Data

Specifies custom data values to associate with this recording segment.

Create custom data fields via the Admin page's **Custom Data Fields** link. For more information on configuring Custom Data, see "Custom Data".



Note:

To add or change detailed information about a recording segment, the user must have permission privileges for the Account's route associated with the recording. To provide permission to add Custom Data Fields, see "Custom Data".

Segment Session Metadata

To view Segment Session Metadata:

1. On the Recordings page, choose a recording and click **Details**. The Recording Details page displays.
2. Click **Segment #** for the segment details you want to view.
3. Click **Session Metadata**. The following information displays.

The screenshot shows the 'Session Metadata' section. It contains two fields:

SIPREC Session ID	slbybsXtQ7pivcNTRvEN4A==
Start Time	2012-01-02 08:44:39 AM

The **SIPREC Session ID** field displays the SIP Recording Session ID assigned to the call recording session at the time the call was received by the RSS.

The **Start Time** field displays the date and time the call recording session began. The date and time are based on the time zone configured for the User.

The **Session Extension Metadata** displays additional extension metadata associated with the session. The metadata types that may be present here include:

- apkt:ucid
- calledPartyNumber
- callID
- callingPartyNumber
- extTrackingID
- groupID
- newExtTrackingID
- serviceProviderID
- userID

Segment Session Participant Metadata

You can view specific participant metadata for a segment, including extension metadata, about a recording by clicking Session Participant Metadata on the Recording Details page.

To view Session Participant Metadata:

1. On the Recordings page, choose a recording and click **Details**. The Recording Details page displays.
2. Click **Segment #** for the segment details you want to view.
3. Click **Session Participant Metadata**. The following information displays.

SIPREC Participant ID	Name	Participant AOR	Start Time	End Time
fhpR4z4qSy5x4H7aEzbsPg==	*sipp_sd_siprec_display*	sipsipp_sd_siprec@10.178.248.32:5070	2012-01-02 08:44:39 AM	
PdDRRcWbSzi0nE7mP5W9Vg==	*rss_sd_siprec_display*	siprss_sd_siprec @10.178.248.38:5060	2012-01-02 08:44:39 AM	

Page 1 of 1 (1-2 of 2 items) < 1 >

The following table describes each field on the Session Participant Metadata page.

Column Heading	Description
SIPREC Participant ID	Specifies the ID of the SIPREC participant on the recording.
Name	Specifies the SIP URI name of the SIPREC participant.
Participant AOR	Specifies the address of record (AOR) associated with the participant.
Start Time	Specifies the date and time when the active session recording began.
End Time	Specifies the date and time when the active session recording ended.

4. Choose a SIPREC Participant ID and click **Details** to display extension metadata information about the participant.

Information in this box can include metadata for:

- apkt:-realm
- apkt:P-Asserted-Identity
- apkt:Diversion
- apkt:request-uri

For more information about these parameters, see "Recording Search by Session".

Displaying DTMF Data in Segment Details: Routes

You can configure the ISR to display DTMF data within a call's recording details for digits transmitted via RFC 2833 and SIP INFO. The **Record DTMF** parameter allows you to specify whether or not to display DTMF details on either a per-route or per-account basis.

To enable the ISR to display DTMF details for a particular route:

1. After logging into the ISR Dashboard, click **Admin**.
2. Click **Routes**.
A list of all routes configured on the ISR displays.
3. Click the route on which you want to enable the recording of DTMF data and click **Edit**.
The Edit Route page displays.
4. Click **Advanced Configuration**.

The screenshot shows the 'Edit Route' page with the 'Advanced Configuration' tab selected. The 'Recording' section is expanded, showing the following settings:

- Route Mode: Standard (SIPREC)
- Recording is: Enabled
- Segmentation State: Disabled
- Percent To Record: 100
- Always Record As Raw RTP: No
- Recording Format Profile: Small
- Record DTMF: No

5. **Record DTMF**—Select whether or not to display DTMF data. Valid values are:
 - Use Account's Setting—This route defaults to its account's behavior.
 - No—No DTMF data appear in the recording details.
 - Yes—data details appear in the recording details.
6. Click **Update**.

Displaying DTMF Data in Segment Details: Accounts

To enable the ISR to display DTMF data for a particular account:

1. After logging into the ISR Dashboard, click **Admin**.
2. Click **Accounts**.
A list of all accounts configured on the ISR displays.
3. Click the account on which you are want to enable the recording of DTMF data and click **Edit**.

4. Click **Route Defaults**.

Accounts

Edit Account

← Back

← Previous 1 Account Configurations 2 Archival Configurations 3 Dashboard Configurations 4 LDAP Configurations 5 Permissions 6 **Route Defaults** 7 Users 8 Video Configurations → Next

Recording Defaults

Route Mode: Standard (SIPREC) Always Record As Raw RTP: No

Recording is: Enabled Codec profile name: Default

Percent To Record: 100 Record DTMF: No

Recording Notes and Scoring Permissions

Record and Save Mode Defaults

Record and Save Mode Defaults

Update Cancel

5. **Record DTMF**—Select whether or not to display DTMF details. Valid values are:
- No—No DTMF data appear in the recording details.
 - Yes—DTMF data appear in the recording details.
 - Use System Account's Setting—This account defaults to the System account's behavior. This is the default value.
6. Click **Update**.

Displaying DTMF Data in Segment Details

To view DTMF data in recording details:

1. After logging into the ISR Dashboard, click **Find Recordings** or click **Recordings** in the top menu bar.
2. Select the recording you want to view and click **Details**.
The Recording's detail page displays.
3. Click **DTMF Events**. The DTMF data appears.

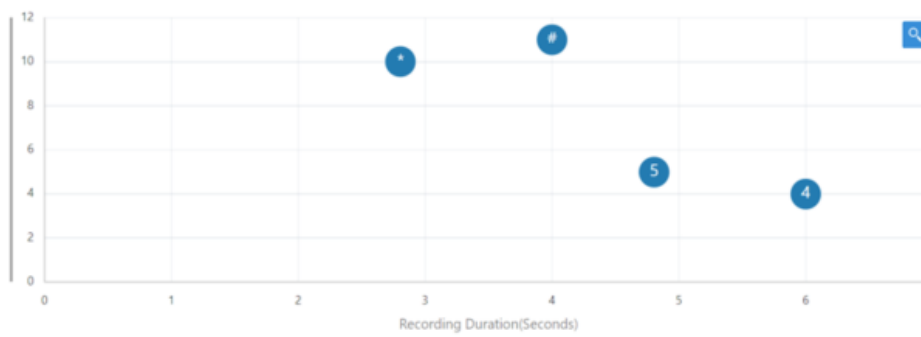

You can zoom in on a particular area of the DTMF Events graph by highlighting the section you want to view. To get back to the original graphical view, click **Reset zoom**.

Deleting a Recording

You can delete a recording from the ISR Dashboard as required.

To delete a Recording:

1. After logging into the ISR Dashboard, click **Recordings** . The Recordings page displays.
2. Choose a Recording from the Recordings page and click **Delete**. The following prompt displays:
Are you sure you want to delete this recording?
3. Click **OK** to delete the Recording from the ISR database or click **Cancel** to cancel the delete function.

 **Note:**

Once a recording is deleted, it cannot be recovered. The file is deleted from disk and the metadata is removed from the database.

17

Managing Reports

The ISR allows you to generate call usage and billing statistical reports using date and route filters. This chapter describes the types of reports you can generate and filters you can use to generate the reports.

Manage Reports

The ISR provides the following types of reports you can generate:

- **Usage Reports**- Generates a report that includes call recorder usage information by date range and/or by route.
- **Billing Reports** - Generates a report that includes billing information by date range and/or by route.

You can run these reports for the current month or the previous month, or specify a date range.

You can access the Reports from the Home page by clicking **Build A Report** (or by clicking **Reports** on the top menu bar).

Reports

The screenshot shows a web interface for generating reports. It features two radio buttons under 'Search Date': 'By Month' (selected) and 'By Range'. Below this is a dropdown menu showing '06/2019'. Underneath is a 'Select Route' field with a 'To - %' label.

Generate Billing Report Generate Usage Report

The Reports page allows you to build Usage and/or Billing Reports based on the filters you set in the **Search Date** and **Select Route** fields.

Usage Reports

Usage Reports show information about calls that use routes configured on your ISR. Usage Reports include:

- Route used for calls
- Number of sessions provisioned on the route
- Number of provisioned burst sessions on the route

- Total number of calls initiated using the route
- Number of calls made during peak time on the route
- Number of calls that used burst sessions on the route
- Number of calls rejected on the route

You can filter the call data by month or by date range, and select a single or multiple routes to display in the report.

Generating a Usage Report

To generate a Usage Report:

1. After logging into the ISR Dashboard, click **Build a Report** on the Home Page (or **Reports** on the main menu bar). The Reports page displays.

Reports

The screenshot shows the 'Reports' page interface. At the top, there is a 'Search Date' section with two radio buttons: 'By Month' (selected) and 'By Range'. Below this is a dropdown menu currently showing '06/2019'. Underneath is a 'Select Route' section with a 'To - %' label. At the bottom of the form area, there are two buttons: 'Generate Billing Report' and 'Generate Usage Report'.

2. **Search Date**—Select whether you want to generate a report by the month or by date range.

Generating a report by month

To generate a report by month:

1. Select **By Month**.
2. In the drop-down box, select the month for which you want to generate the report. Valid values are dependent on the dates for calls stored in the ISR database.

Generating a report by range

To generate a report by range:

1. Select **By Range**. The **From Date** and **To Date** fields display.
2. **From Date**—Click the cursor in the text box or click the Calendar icon to display the calendar.
3. Click the date from where you want to begin to include the report data. Use the arrow keys in the calendar to change months.
4. **To Date**—Click the cursor in the text box or click the Calendar icon to display the calendar.
5. Click the date from where you want to end the inclusion of the report data. Use the arrow keys in the calendar to change months.

Selecting a route

To select a route:

1. **Select Route**—Select a route or routes to include in the report. Valid values are dependent on the routes currently configured in the ISR database.

Note:

To select multiple routes, click on a route in the selection box, press and hold the <Ctrl> key, and select additional routes.

2. Click **Generate Usage Report** to generate the Usage Report. The following report displays.

Usage Report



The Usage Report displays the information in bar graph format at the top of the page, and in data format at the bottom of the page.

Usage Report Bar Graph Descriptions

The following table identifies the information in the bar graph section of the report.

Usage Report Bar Graph Descriptions

Graph Information	Description
Routes (Policies)	Indicates the route(s) selected for this report.
Sessions	Indicates the number of sessions handled by the route.

Graph Information	Description
Recorded	Indicates total number of recorded sessions on the route during the reported period.
Sessions Rejected	Indicates total number of rejected sessions on the route during the reporting period.
Burst Sessions	Indicates total number of burst sessions on the route during the reporting period. Burst sessions are sessions handled by the Burst Ports.
Peak Sessions	Indicates maximum number of simultaneous sessions on the route during the reporting period.
Total Sessions	Indicates total number of sessions on the route during the reporting period.

The following table describes each column in the data format section of the report.

Usage Report Data Format Descriptions

Column	Description
Type	The type of route policy (for example, To, From, or To/From).
Pattern	The route pattern that the RSS looks for when searching for a route policy.
Capacity	Total concurrent sessions allocated to the route.
Burst Capacity	Number of concurrent sessions available for call recording when the provisioned capacity has been depleted.
Total Sessions	The total number of sessions for this reporting period.
Peak Sessions	The maximum number of concurrent sessions that occurred during this reporting period.
Burst Sessions	The total number of sessions that occurred after the provisioned capacity had been depleted.
Rejected	Total number of rejected sessions on this route during this reporting period.
System Rejected	The total number of rejected sessions by the ISR during this reporting period.



 **Note:**

This data is only available in a day by day breakdown.

Account Rejected	The total number of rejected sessions by this account during this reporting period.
------------------	---

 **Note:**

This data is only available in a day by day breakdown.

Column	Description
Route Rejected	The total number of rejected sessions by this route during this reporting period.
	<div style="border: 1px solid #ccc; background-color: #e6f2ff; padding: 10px; margin-top: 10px;"> <p> Note:</p> <p>This data is only available in a day by day breakdown.</p> </div>
Recorded	Total number of recorded sessions on this route during this reporting period.
Percent Recording Rejected	Total number of sessions rejected during this reporting period because of the route's percent to record setting.
	<div style="border: 1px solid #ccc; background-color: #e6f2ff; padding: 10px; margin-top: 10px;"> <p> Note:</p> <p>This data is only available in a day by day breakdown.</p> </div>

After you have generated a usage report, you can click on the details icon for a specific route within the report to view a day by day breakdown of the statistics.

Detailed Stats for Route %							
Date	Total Sessions	Peak Sessions	Burst Sessions	Sessions Rejected	System Rejected	Account Rejected	Route Rejected
2019-06-19	7	1	0	0	0	0	0

Billing Reports

Billing Reports show information about calls that use the routes configured on your ISR. Billing Reports include:

- Route used for calls
- Number of sessions provisioned on the route
- Number of provisioned burst sessions on the route
- Total number of calls initiated using the route
- Number of calls made during peak time on the route
- Number of calls that used burst sessions on the route
- Number of calls rejected on the route

You can filter the call data by month or by date range, and select a single or multiple routes to display in the report. You can use this information for billing purposes as required.

Generating a Billing Report

To generate a Billing Report:

1. After logging into the ISR Dashboard, click **Build a Report** on the Home Page (or **Reports** on the main menu bar). The Reports page displays.

Reports

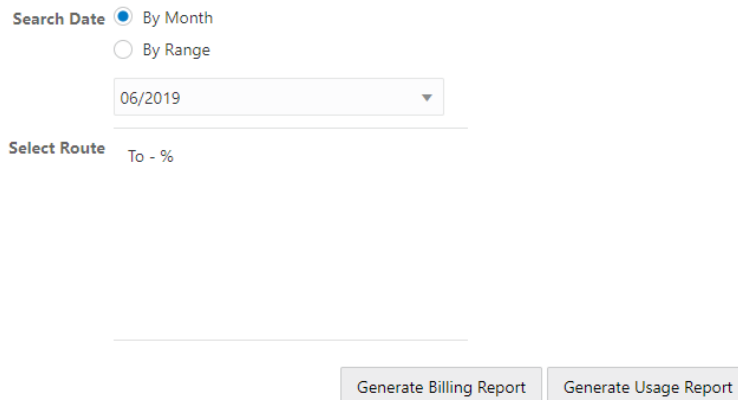

The screenshot shows the 'Reports' interface. At the top, there are two radio buttons for 'Search Date': 'By Month' (selected) and 'By Range'. Below these is a dropdown menu showing '06/2019'. Underneath is a 'Select Route' field with a 'To - %' label. At the bottom right, there are two buttons: 'Generate Billing Report' and 'Generate Usage Report'.

2. **Search Date**—Select whether you want to generate a report by the month or by date range.

Generating a Report by Month

To generate a report by month:

1. Select **By Month**.
2. In the drop-down box, select the month for which you want to generate the report. Valid values are dependent on the dates for calls stored in the ISR database.

Generating a Report by Range

To generate a report by range:

1. Select **By Range**. The **From Date** and **To Date** fields display.
2. **From Date**—Click the cursor in the text box or click the Calendar icon to display the calendar.
3. Click the date from where you want to begin to include the report data. Use the arrow keys in the calendar to change months.
4. **To Date**—Click the cursor in the text box or click the Calendar icon to display the calendar.
5. Click the date from where you want to end the inclusion of the report data. Use the arrow keys in the calendar to change months.

Selecting a Route

To select a route:

1. **Select Route**—Select a route or routes to include in the report. Valid values are dependent on the routes currently configured in the ISR database.

 **Note:**

To select multiple routes, click on a route in the selection box, press and hold the <Ctrl> key, and select additional routes.

2. Click **Generate Billing Report** to generate the Billing Report. The following report displays.

Billing Report

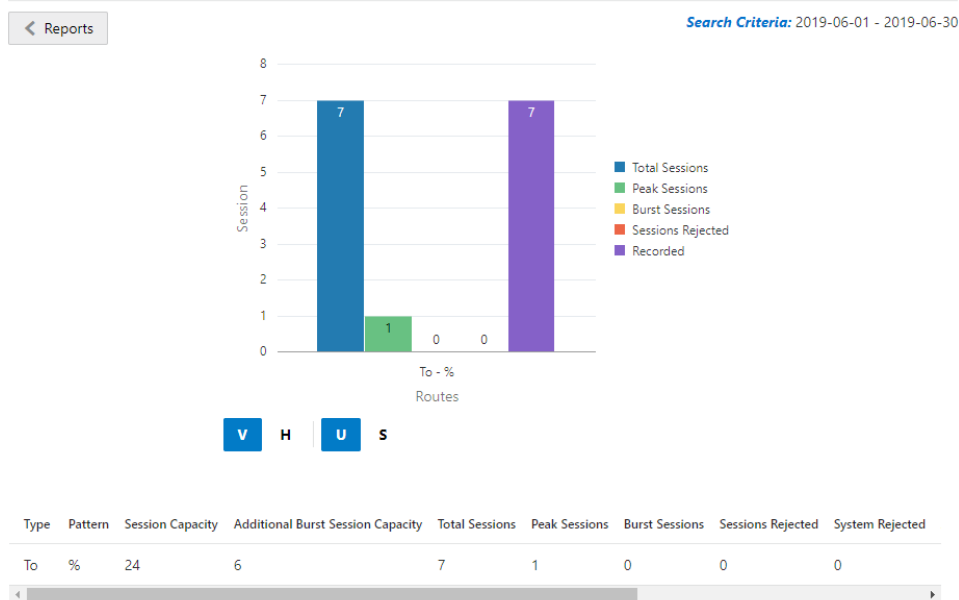

The Billing Report displays the information in bar graph format at the top of the page, and in data format at the bottom of the page.

Billing Report Bar Graph Descriptions

The following table identifies the information in the bar graph section of the report.

Billing Report Bar Graph Descriptions

Graph Information	Description
Routes (Policies)	Indicates the route(s) selected for this report.
Sessions	Indicates the number of sessions handled by the route.
Recorded	Indicates total number of recorded sessions on the route during the reported period.

Graph Information	Description
Sessions Rejected	indicates total number of rejected sessions on the route during the reporting period.
Burst Sessions	Indicates total number of burst sessions on the route during the reporting period. Burst sessions are sessions handled by the Burst Ports.
Peak Sessions	Indicates maximum number of simultaneous sessions on the route during the reporting period.
Total Calls	Indicates total number of sessions on the route during the reporting period.

The following table describes each column in the data format section of the report.

Billing Report Data Format Descriptions

Column	Description
Type	The type of route policy (i.e., To, From, or To/From).
Pattern	The route pattern that the RSS looks for when searching for a route policy.
Capacity	Total concurrent sessions allocated to the route.
Burst Capacity	Number of concurrent sessions available for call recording when the provisioned capacity has been depleted.
Total Sessions	The total number of sessions for this reporting period.
Peak Sessions	The maximum number of concurrent sessions that occurred during this reporting period.
Burst Sessions	The total number of sessions that occurred after the provisioned capacity had been depleted.
Rejected	Total number of rejected sessions on this route during this reporting period.
System Rejected	The total number of rejected sessions by the ISR during this reporting period.
Account Rejected	The total number of rejected sessions by this account during this reporting period.
Route Rejected	The total number of rejected sessions by this route during this reporting period.
Recorded	Total number of recorded sessions on this route during this reporting period.
Percent Recording Rejected	Total number of sessions rejected during this reporting period because of the route's percent to record setting.

 **Note:**

This data is only available in a day by day breakdown.

A

Software Diagrams and Call Setup Sequence

This appendix contains a high-level, software architecture diagram of the ISR platform along with a set of ladder diagrams describing interaction of the software components. This is for informational purposes only.

ISR Recorder Process Architecture Diagram

The following is a diagram of the ISR recorder process architecture.

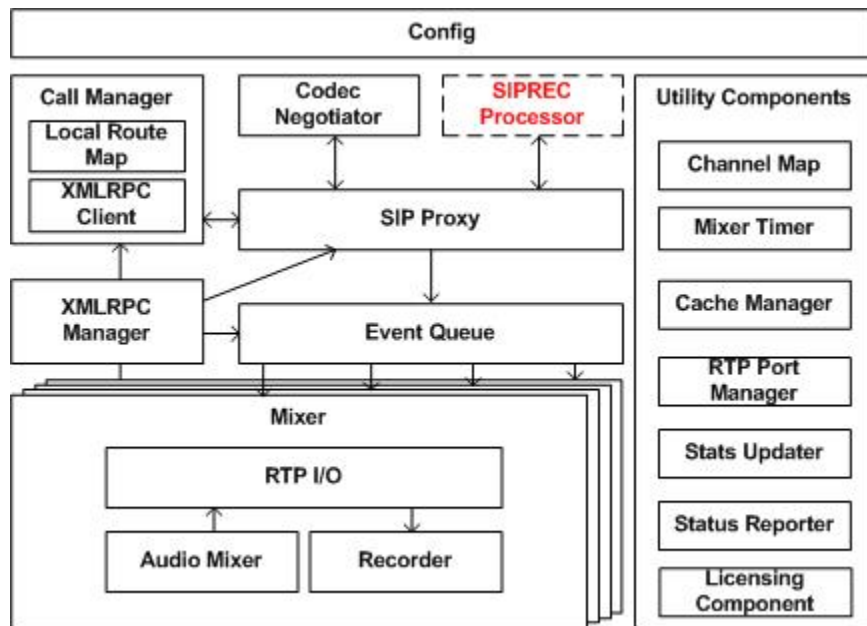

Description of Components

The components of the ISR consist of the following:

- RSS - Record Store Server
- CIS - Control Index Server

Each of these components are described in the following paragraphs.

Record Store Server (RSS)

The RSS consists of the following components:

- Call Manager - Using call state, channel and route information Call Manager handles account and platform-related call decisions.

- SIP Agent - Processor for SIP-related events.
- Channel Map - State storage and reference for active call information and available channels.
- Local Route Cache - Binary tree store of route-based information for call and recording decisions. Initializes reflecting the dashboard-driven route_config database table with periodic (configurable) updates mirroring changes in the table.
- Call Stats Updater - Processes call metrics and refreshes call and recording tables with call statistics.
- RTP Port Manager - Returns available RTP ports and maintains port status for SIP Agent.
- Event Queue - Prioritizes and stores call and other events
- Cache Manager - Local audio store which makes available audio content such as busy messages and beeps during recording.
- Mixer Channel - RTP support for sending, receiving, buffering, transcoding and mixing audio which contains the following:
 - RTP I/O - RTP input and output stream handling.
 - Audio Mixer - Audio stream processing for injecting platform or route-specific audio.
 - Recorder Thread - Manages audio and file stream processing.
- RSS API - offers ISR remote call and recording services along with resources for route and channel references in ISR database.
- RSS API Servlet - Service handles ISR XML-RPC API requests.
- REST API - REST resource for ISR API commands.
- Archiver
- SIPREC - Used to interact between a Session Recording Client (SRC) and a Session Recording Server (SRS).
 - Codec Negotiator - Responsible for generating supported Codec list for SDP offers and answers to offers.
 - SIPREC Processor - This component is responsible for processing SIPREC requests. When the SIP Proxy receives a SIPREC call, judging by multipart bodies, it passes call context and SIPREC Metadata to SIPREC process. The SIPREC Processor then parses the Metadata of the Recording Session (RS) into a structured data object. The SIPREC Processor, in turn, passes the call context back to SIP Proxy with flag set for detailed instructions on SIP signaling. Note: Final SIP action for SIPREC from SIP Proxy, afterward, is also affected by Call Manager.

Control Index Server (CIS)

The CIS consists of the following components:

- ISR Index
- ISR User Dashboard
- ISR Monitor
- ISR FACE

Sequence Diagrams

This section provides details about the ISR call setup for a single successful call. This is for informational purposes only.

Non-SIPREC Call

The following sequence diagram applies to the ISR configuration in non-SIPREC, pass-through, interactive voice response (IVR) skip mode. The call applies to a percentage-based recording route.

The simple call flow below reflects a single successful call which applies to a route configured for pass-through mode and recording of 100% of calls. The diagram highlights some of the features in the ISR, such as IVR-skip mode. Previously, the ISR architecture required a VoiceXML platform to make routing, recording and availability decisions. This information now resides locally in the Local Route Cache or is referenced in the database through API commands.

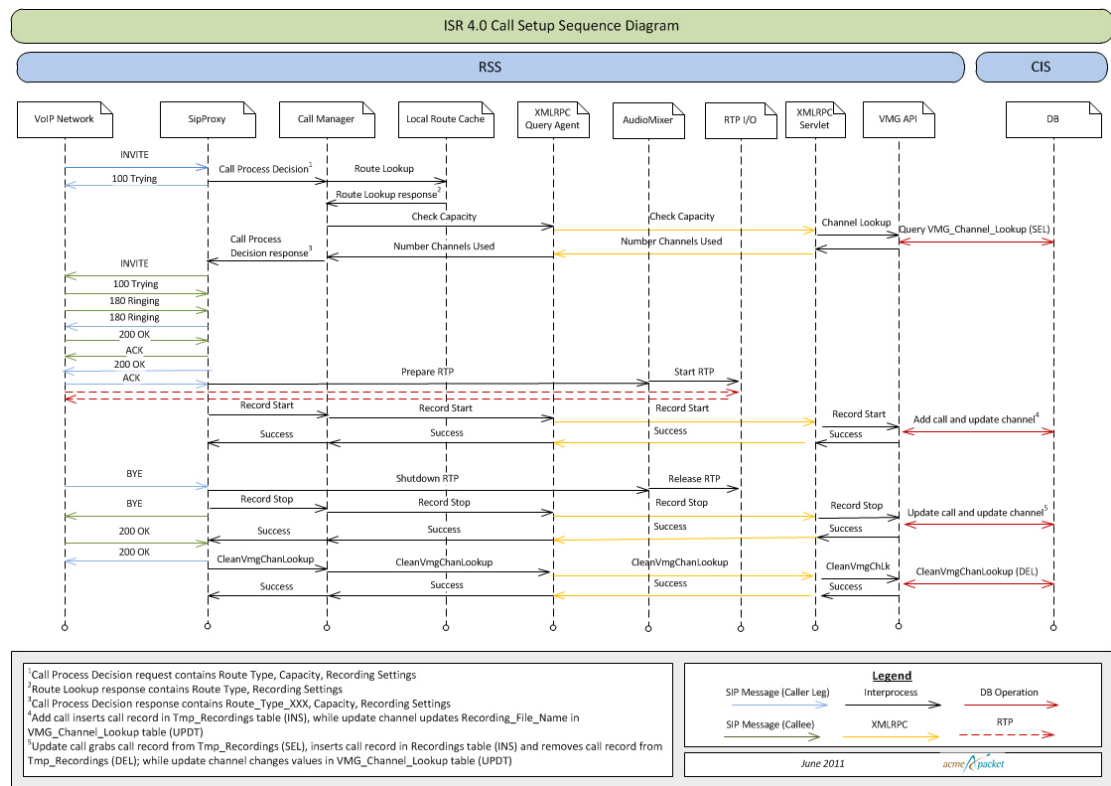

ISR Call Setup Sequence Diagram

SIPREC Call

The following sequence diagram applies to the ISR configuration in SIPREC environment.

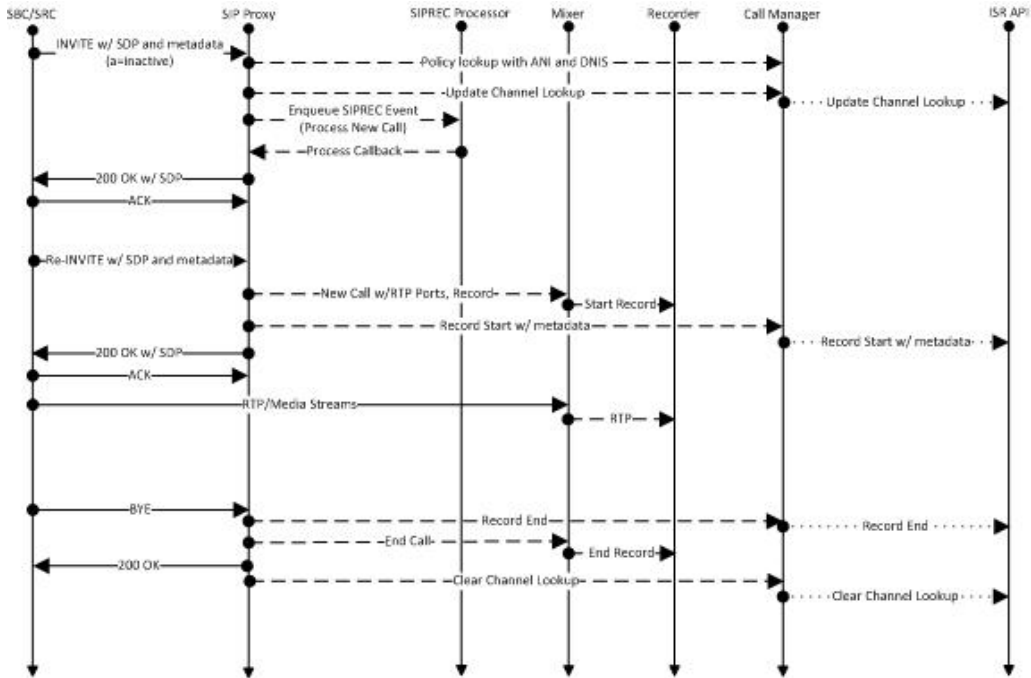

B

ISR Linux Users and File Permissions

This section lists the ISR Linux Users and File Permissions.

Component	Type	File Name	Permissions	Owner
Recorder	log	/opt/isr/logs/ recorder/ ISRService.log	-rw-rw-rw-	isr
Recorder	log	/opt/isr/logs/ recorder/ recorder.log	-rw-r--r--	isr
Recorder	recordings	/opt/isr/ Recordings/*.*	-rw-rw-rw-	isr
Recorder	binary	/opt/isr/rss/isrl.elf	-rwxr-xr-x	isr
Converter	log	/opt/isr/logs/ converter/ converter.log	-rw-r--r--	isr
Converter	log	/opt/isr/logs/ converter/ converterService.lo g	-rw-r--r--	isr
Converter	binary	/opt/isr/rss/ converterl.elf	-rwxr-xr-x	isr
API	log	/opt/isr/logs/api/ api.log	-rw-r--r--	tomcat
API	config	/var/lib/tomcat/ webapps/IsrApi/ WEB-INF/web.xml	-rwxr--r--	tomcat
API	code	/var/lib/tomcat/ webapps/ IsrApi/**/*.*	-rw-r--r--	tomcat
EEN	log	/opt/isr/logs/ ApiLog/ IsrApiEvent.log	-rw-r--r--	tomcat
Archiver	log	/opt/isr/logs/ Archiver/ ISRArchivalService .log	-rw-r--r--	tomcat
Archiver	recordings	/opt/isr/ ArchivedRecording s/*.*	-rwxrw-r--	tomcat
Archiver	code	/var/lib/tomcat/ webapps/ ISRArchivalService /**/*.*	-rw-r--r--	tomcat

Component	Type	File Name	Permissions	Owner
Archiver	config	/var/lib/tomcat/ webapps/ ISRArchivalService //WEB-INF/ web.xml	-rw-r--r--	tomcat
RSS Web Server	log	/etc/tomcat/ server.xml	-rw-rw-r--	tomcat
RSS Web Server	log	/var/log/tomcat/ catalina.<yyyy-mm- dd>.log	-rw-r--r--	tomcat
RSS Web Server	log	/var/log/tomcat/ localhost_access_l og.<yyyy-mm- dd>.txt	-rw-r--r--	tomcat
RSS Web Server	log	/etc/tomcat/ server.xml	-rw-rw-r--	tomcat
Dashboard	log	/var/log/puma/ puma.log	-rw-r--r--	puma
Dashboard	config	/opt/isr/puma/ puma_config.rb	-rw-r--r--	puma
Dashboard	binary	/usr/bin/puma*	-rw-r--r--	puma
Dashboard	siyrce	/usr/lib64/ruby/ gems/2.3.0/gems/ puma-3.4.0/**/*	-rw-r--r--	puma
Dashboard	log	/opt/isr/logs/ dashboard/ production.log	-rw-r--r--	puma
Dashboard	config	/var/www/ dashboard/current/ config/*.*	-r--r--r--	puma
Dashboard	source	/var/www/ dashboard/ current/app/**/*	-r--r--r--	puma
Face	log	/opt/isr/logs/Face/ Face.log	-rw-r--r--	tomcat
Face	config	/var/lib/tomcat/ webapps/Face/ WEB-INF/web.xml	-rw-r--r--	tomcat
Face	code	/var/lib/tomcat/ webapps/ Face/**/*.*	-rw-r--r--	tomcat
Index	config	/etc/my.cnf	-rw-r--r--	mysql
Index	log	/var/lib/mysql/ index.err	-rw-r-----	mysql
Index	log	/var/log/mysqld.log	-rw-r-----	mysql
Index	data	/var/lib/mysql/**/*	-rw-r--r--	mysql
Provision API	log	opt/isr/logs/provapi/ init.error.log	-rwxr-xr-x	tomcat
Provision API	log	opt/isr/logs/provapi/ init.log	-rwxr-xr-x	tomcat
Provision API	log	opt/isr/logs/provapi/ provapi.log	-rwxr-xr-x	tomcat

Component	Type	File Name	Permissions	Owner
Provision API	config	opt/isr/ application.properties	-rwxr-xr-x	isr
Provision API	config	opt/isr/ log4j2.properties	-rwxr-xr-x	isr
Provision API	llog	opt/isr/logs/provapi/ logs/ localhost_access_log	-rwxr-xr-x	tomcat

ISR Third-Party Platform File Permissions

The following set of users are added to the "isr" group due to platform dependencies of the ISR applications.

- tomcat
- mysql
- puma

C

ISR Dashboard Database Failover

To support a high availability (HA) Index environment, the ISR Dashboard supports both primary and secondary production databases.

The Dashboard always attempts to connect to the primary Index first and the secondary database is only used when the Dashboard fails to connect to the primary database. If the Dashboard cannot connect to the secondary Index database, the ISR displays an error.

Configuring ISR Dashboard Database High Availability

The Dashboard's `/opt/isr/configIsr.sh` script has two options which allow you to configure Dashboard database HA. After starting the script, select the **d** option to add or modify the secondary Index host database configuration. Select the **r** option to delete the secondary Index host database configuration. For either option, follow the on-screen options when prompted.

D

Logging Into ObserveIT Visual Session Recording

When the ISR Dashboard encounters a valid FACE configuration accompanied by a recording playback request with associated screen capture "slides", Dashboard playback functionality launches. This begins with a single request for ObserveIT Visual Session Recording credentials to authorize the ISR Dashboard session for screen capture playback.

The following login screen appears prompting you for these credentials:



A screenshot of a web browser window titled "ObserveIT Credentials". The window contains a message: "This is the first time you are attempting to playback from this ObserveIT server, please enter your ObserveIT server credentials below." Below the message are two input fields: "Username" and "Password". A "Submit" button is located at the bottom right of the form.

Once you successfully enter the **Username** and **Password**, both audio and screen capture video begin playing and a sliding bar appears with the controls for pause/resume and volume, as well as a display marking the current playback time within the recorded session. An interactive **User Activities List** panel also appears which contains a list of notable user events. By clicking on any of these items in the list, the recording jumps playback to the specified event.

The following example displays playback of audio and screen capture:

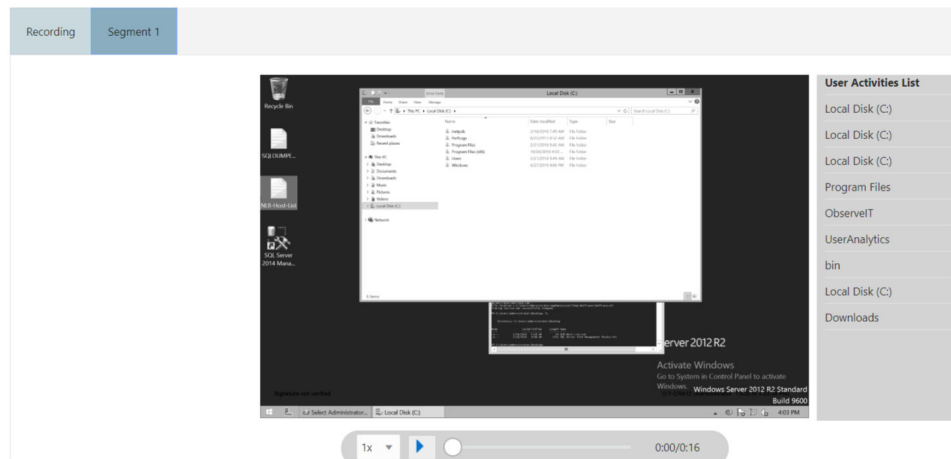

A screenshot of the ObserveIT playback interface. The interface is divided into three main sections. On the left, there are tabs for "Recording" and "Segment 1". The central area displays a video player showing a Windows Server 2012 R2 desktop environment with a file explorer window open. On the right, there is a "User Activities List" panel with a scrollable list of events including "Local Disk (C)", "Program Files", "ObserveIT", "UserAnalytics", "bin", and "Downloads". At the bottom, there is a playback control bar with a volume icon, a play/pause button, a progress slider, and a time display showing "0:00/0:16".

Click the **OK** button to return to the previous page once you are finished with playback.

E

ISR Accessibility Features

This topic provides an overview of the approach towards accessibility in the Public Sector Compliance and Regulation services.

The Public Sector Compliance and Regulation services are developed with the latest industry standards for accessibility in mind, which is in keeping with the overall development approach within Oracle.

Oracle recognizes the need for our applications, and our customers' and partners' products built with our tools, to be usable by the disabled community. The Oracle Accessibility Program Office, reporting to the office of the Chief Corporate Architect, is responsible for defining the corporate standards for accessibility, and developing materials to train all employees so that they can successfully create products that meet those standards.

For information about Oracle's commitment to accessibility, visit the Oracle Accessibility Program website at <http://www.oracle.com/us/corporate/accessibility/index.html>.

Oracle uses the Voluntary Product Accessibility Template (VPAT) to represent the degree of conformance to various accessibility standards and guidelines, including Section 508 (as released in 2001), WCAG 1.0, and WCAG 2.0. Depending on when a product was developed and released, different standards may be listed. Oracle is an active member on the ITI group that is working to enhance the VPAT to address future standards.

For more information about Oracle's published VPAT documents, see the Product Status (VPATs) page at <http://www.oracle.com/us/corporate/accessibility/vpats/index.html>.

Using General Keyboard Shortcuts

The following table lists and describes the supported general keyboard shortcuts.

Keyboard Shortcut	Description
<TAB>	This is the primary key used by all keyboard users to move from each control that can accept focus. <ul style="list-style-type: none">• Use <TAB> to select any actionable or field just like you can use the mouse to select any field on the page.• For folder tabs, the <TAB> key will take you to a tab, and then you have to use other keys to select and navigate within that tab.• For drop-down lists, the <TAB> key will take you to the list field, and then you have to use other keys to move through values and select values.
<SHIFT>+<TAB>	This keyboard combination works the same as <TAB>, except it works in the opposite direction. For example, it enables you to switch focus to the previous control or field, rather than the next control or field.

Keyboard Shortcut	Description
<SPACEBAR>	Use for: <ul style="list-style-type: none"> • Selecting a tab • Activating a button • Selecting a check box • Selecting a radio button that is not selected
<ENTER>	Use to: <ul style="list-style-type: none"> • Press a button. • Click a link. • Select an item from a drop-down list.
<DOWN ARROW>	Use for: <ul style="list-style-type: none"> • Moving through values in a drop-down list • Selecting different values in a set of radio buttons • Moving between different folder tabs
<UP ARROW>	Works the same as the <DOWN ARROW>, except it enables you to move in the opposite direction (previous instead of next).
<LEFT ARROW>	Works similar to the <UP ARROW>.
<RIGHT ARROW>	Works similar to the <UP ARROW>.
<HOME>	When in the context of tabs, sets focus to the first tab.
<CTRL>+<HOME>	Takes you to the very top of a page.

Using the Keyboard with Tables

This section describes how to navigate within tables appearing on a page in the ISR Dashboard.

RSS Ingress Call ID	Start Time	From	To	Duration
1-1824@10.178.248.28	2020-03-02 04:05:11 AM	sipp_amrwb	rss_amrwb	10 seconds
10-20618@10.176.226.122	2020-03-01 11:21:29 PM	sipp_sd_siprec	rss_sd_siprec	10 seconds
9-20618@10.176.226.122	2020-03-01 11:21:29 PM	sipp_sd_siprec	rss_sd_siprec	10 seconds
8-20618@10.176.226.122	2020-03-01 11:21:29 PM	sipp_sd_siprec	rss_sd_siprec	10 seconds
7-20618@10.176.226.122	2020-03-01 11:21:29 PM	sipp_sd_siprec	rss_sd_siprec	10 seconds
6-20618@10.176.226.122	2020-03-01 11:21:29 PM	sipp_sd_siprec	rss_sd_siprec	10 seconds
5-20618@10.176.226.122	2020-03-01 11:21:29 PM	sipp_sd_siprec	rss_sd_siprec	10 seconds
4-20618@10.176.226.122	2020-03-01 11:21:29 PM	sipp_sd_siprec	rss_sd_siprec	10 seconds
3-20618@10.176.226.122	2020-03-01 11:21:29 PM	sipp_sd_siprec	rss_sd_siprec	10 seconds
2-20618@10.176.226.122	2020-03-01 11:21:29 PM	sipp_sd_siprec	rss_sd_siprec	10 seconds
1-20618@10.176.226.122	2020-03-01 11:21:28 PM	sipp_sd_siprec	rss_sd_siprec	10 seconds
1-20597@10.176.226.122	2020-03-01 11:12:29 PM	sipp_sd_siprec	rss_sd_siprec	10 seconds
1-20594@10.176.226.122	2020-03-01 11:12:13 PM	sipp_sd_siprec	rss_sd_siprec	0 seconds
10-20533@10.176.226.122	2020-03-01 10:46:20 PM	sipp_sd_siprec	rss_sd_siprec	10 seconds
9-20533@10.176.226.122	2020-03-01 10:46:20 PM	sipp_sd_siprec	rss_sd_siprec	10 seconds
8-20533@10.176.226.122	2020-03-01 10:46:20 PM	sipp_sd_siprec	rss_sd_siprec	10 seconds

The following table lists and describes the keys used to move around the cells of a table.

Key	Description
<TAB>	The first Tab into the table moves focus to the first column header. The second Tab moves focus to the next focus-able element.
<SHIFT>+<TAB>	The first Shift+Tab into the table moves focus to the first column header. The second Shift+Tab moves focus to the previous focus-able element.
<DOWN ARROW>	Move focus to the next row.
<SHIFT>+<DOWN ARROW>	Select and move focus to the next row.
<UP ARROW>	Move focus to the previous row. If at the first row, then move to the column header.
<SHIFT>+<UP ARROW>	Select and move focus to the previous row.
<HOME>	Move focus to first row.
<END>	Move focus to last row.
<SPACEBAR>	Selects the entire row in the table.

The following table lists and describes the keys used to move around the column headers of a table.

Key	Description
<TAB>	Navigate to next focus-able element on page (outside table).
<SHIFT>+<TAB>	Navigate to previous focus-able element on page (outside table).
<DOWN ARROW>	Move focus to the first row.
<LEFT ARROW>	Move focus to previous column header.
<RIGHT ARROW>	Move focus to next column header.
<HOME>	Move focus to first column header.
<END>	Move focus to last column header.
<SPACEBAR>	Select column.

Using the Keyboard to Work with Page Controls

This topic provides examples of how to use the keyboard to work with various controls in the interface and select actionable items. Controls are UI constructs such as buttons, accordions, and page tabs.

Buttons

The following table lists and describes the keys you can use to control buttons in the global header or within pages.



Key	Description
<ENTER>, <SPACEBAR>, <DOWN ARROW>	Open the menu.
<ESC>	Close the menu.

Calendar

The following table lists and describes the keys you can use when working with the calendar control and date picker to select date field values.

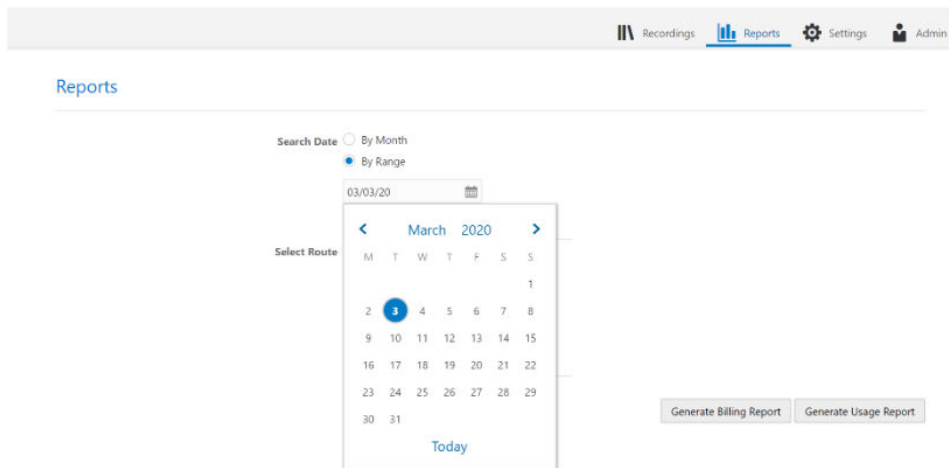

Key	Description
<ENTER>	Select the currently focused day.
<UP ARROW>	Move up in the grid.
<DOWN ARROW>	Move down in the grid.
<RIGHT ARROW>	Move right in the grid.
<LEFT ARROW>	Move left in the grid.
<ESC>	Close the grid.
<HOME>	Move focus to first day of the month.
<END>	Move focus to last day of the month.
<PAGE UP>	Switch to previous month.

Key	Description
<PAGE DOWN>	Switch to next month.
<ALT> + <PAGE UP>	Switch to previous year.
<ALT> + <PAGE DOWN>	Switch to next year.
<CTRL> + <ALT> + <T>	Places focus on Today button if it exists.

Navigation Lists

The following table lists the keys to use to work with navigation lists to access items used to take you to different locations or display additional content.

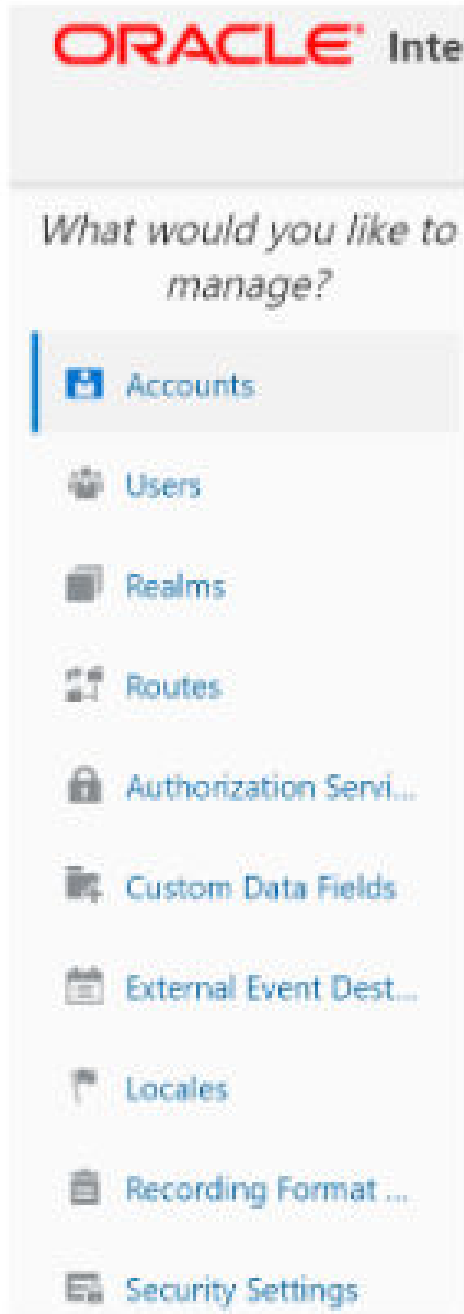

Key	Description
<ENTER> or <SPACEBAR>	Selects list item.
<UP ARROW>	Moves focus to the previous visible list item.
<DOWN ARROW>	Moves focus to the next visible list item.

Key	Description
<RIGHT ARROW>	For horizontal navigation list, focus is moved to next visible item.
<LEFT ARROW>	For horizontal navigation list, focus is moved to previous visible item.
<HOME>	Moves focus to the first visible list item.
<END>	Moves focus to the last visible list item.
<SHIFT> + <TAB>	Move focus to hierarchical menu button. Only applicable for sliding navigation list and when hierarchical menu button is enabled.

Toggle Switch

The following table lists the keys to use to work with toggle switches to enable and disable some of the options.

Routes

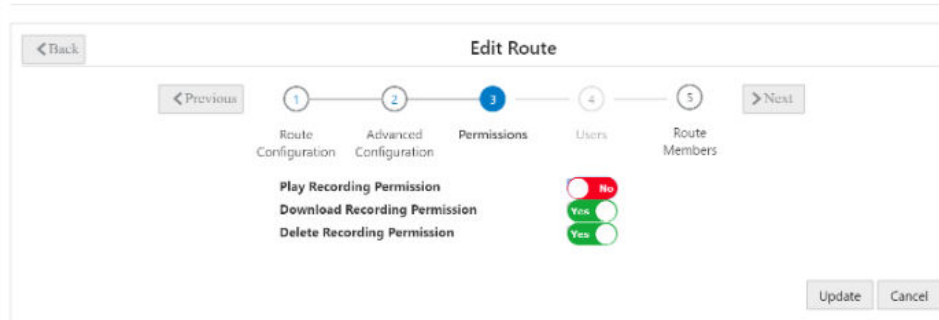

Key	Description
<TAB>	Navigate to the next available toggle.
<SHIFT> + <TAB>	Navigate to the previous available toggle.
<SPACEBAR>	Toggle a particular switch.

Train Stops

The following table lists the keys to use to work with train stop toggles.

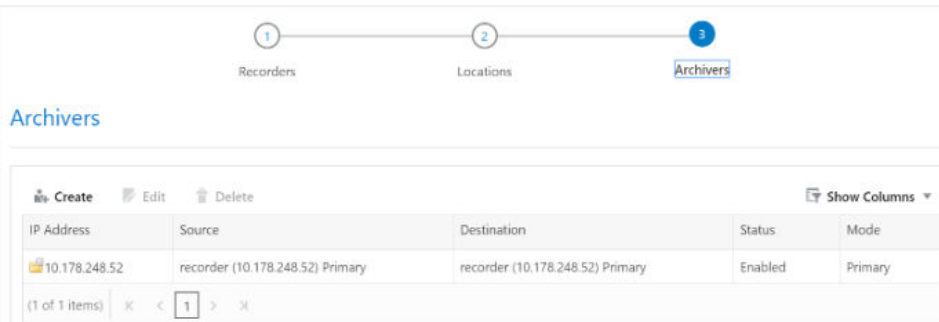

Key	Description
<TAB>	Navigate to the next available train stop.

Key	Description
<SHIFT> + <TAB>	Navigate to the previous available train stop.
<SPACEBAR>	Select the particular train stop.