

Oracle® Communications

EAGLE Previously Released Features

Reference



Release 47.1

F88482-01

October 2023

The Oracle logo, consisting of the word "ORACLE" in white, uppercase, sans-serif font, centered within a solid red square.

ORACLE®

Oracle Communications EAGLE Previously Released Features Reference, Release 47.1

F88482-01

Copyright © 1993, 2023, Oracle and/or its affiliates.

This software and related documentation are provided under a license agreement containing restrictions on use and disclosure and are protected by intellectual property laws. Except as expressly permitted in your license agreement or allowed by law, you may not use, copy, reproduce, translate, broadcast, modify, license, transmit, distribute, exhibit, perform, publish, or display any part, in any form, or by any means. Reverse engineering, disassembly, or decompilation of this software, unless required by law for interoperability, is prohibited.

The information contained herein is subject to change without notice and is not warranted to be error-free. If you find any errors, please report them to us in writing.

If this is software, software documentation, data (as defined in the Federal Acquisition Regulation), or related documentation that is delivered to the U.S. Government or anyone licensing it on behalf of the U.S. Government, then the following notice is applicable:

U.S. GOVERNMENT END USERS: Oracle programs (including any operating system, integrated software, any programs embedded, installed, or activated on delivered hardware, and modifications of such programs) and Oracle computer documentation or other Oracle data delivered to or accessed by U.S. Government end users are "commercial computer software," "commercial computer software documentation," or "limited rights data" pursuant to the applicable Federal Acquisition Regulation and agency-specific supplemental regulations. As such, the use, reproduction, duplication, release, display, disclosure, modification, preparation of derivative works, and/or adaptation of i) Oracle programs (including any operating system, integrated software, any programs embedded, installed, or activated on delivered hardware, and modifications of such programs), ii) Oracle computer documentation and/or iii) other Oracle data, is subject to the rights and limitations specified in the license contained in the applicable contract. The terms governing the U.S. Government's use of Oracle cloud services are defined by the applicable contract for such services. No other rights are granted to the U.S. Government.

This software or hardware is developed for general use in a variety of information management applications. It is not developed or intended for use in any inherently dangerous applications, including applications that may create a risk of personal injury. If you use this software or hardware in dangerous applications, then you shall be responsible to take all appropriate fail-safe, backup, redundancy, and other measures to ensure its safe use. Oracle Corporation and its affiliates disclaim any liability for any damages caused by use of this software or hardware in dangerous applications.

Oracle®, Java, and MySQL are registered trademarks of Oracle and/or its affiliates. Other names may be trademarks of their respective owners.

Intel and Intel Inside are trademarks or registered trademarks of Intel Corporation. All SPARC trademarks are used under license and are trademarks or registered trademarks of SPARC International, Inc. AMD, Epyc, and the AMD logo are trademarks or registered trademarks of Advanced Micro Devices. UNIX is a registered trademark of The Open Group.

This software or hardware and documentation may provide access to or information about content, products, and services from third parties. Oracle Corporation and its affiliates are not responsible for and expressly disclaim all warranties of any kind with respect to third-party content, products, and services unless otherwise set forth in an applicable agreement between you and Oracle. Oracle Corporation and its affiliates will not be responsible for any loss, costs, or damages incurred due to your access to or use of third-party content, products, or services, except as set forth in an applicable agreement between you and Oracle.

Contents

1 Introduction

1.1	Overview	1-1
1.2	Scope and Audience	1-1
1.3	Features Added in This Revision	1-1
1.4	Documentation Admonishments	1-1
1.5	Manual Organization	1-2
1.6	Related Publications	1-2
1.7	Locate Product Documentation on the Oracle Help Center Site	1-2

2 Features Num - E

2.1	1M System TPS (Release 45.0)	2-1
2.1.1	Feature Control Requirements	2-1
2.2	3 Links per E5-ATM Card (Release 43.0)	2-2
2.2.1	Feature Control Requirements	2-2
2.3	5 Minute Linkset Data (Release 25.0)	2-2
2.4	5-8 Bit Sequencing Assurance (Release 24.0)	2-3
2.5	6-Way Loadsharing on Routesets (Release 41.0)	2-5
2.5.1	Feature Control Requirements	2-5
2.5.2	Limitations	2-5
2.6	8-Bit SLS Support (Release 21.0)	2-5
2.7	15 Minute Measurements (Release 31.3)	2-6
2.8	18 GB to 36 GB Hard Drive Upgrade (Release 29.1) (IP7 Release 7.1)	2-6
2.9	24-Bit ITU-N Point Code Support Feature (Release 31.0)	2-7
2.10	48 Million Numbers (Release 27.0)	2-7
2.11	56 Million G-Flex Entries (Release 29.1) (IP7 Release 7.1)	2-12
2.12	64 PC support in M3UA DAUD message (Release 42.0)	2-12
2.13	80 SE-HSLs on E5 Cards (Release 41.1)	2-13
2.13.1	Feature Control Requirements	2-13
2.13.2	Hardware Requirements	2-13
2.14	96M Database on E5-SM4G card (Release 38.0, EPAP 10.0)	2-13
2.14.1	Feature Control Requirements	2-13
2.14.2	Hardware Requirements	2-13

2.14.3	Limitations	2-13
2.15	120 Million EPAP DN/IMSI Entries (Release 39.1)	2-14
2.15.1	Hardware Requirements	2-14
2.15.2	Limitations	2-14
2.16	120 Million LNP Numbers (Release 32.0)	2-15
2.17	120 SE-HSL Support (Release 46.0)	2-15
2.18	120M DN and 120M IMSIs via Split Database (Release 45.0)	2-16
2.18.1	Feature Control Requirements	2-16
2.18.2	Hardware Requirements	2-16
2.19	120M DNs plus 120M IMSIs via Split Database (EPAP 15.0)	2-17
2.20	192 Million LNP Numbers (Release 34.0, ELAP 5.0)	2-17
2.21	228 Million LNP Numbers (ELAP 6.0)	2-18
2.22	228 Million LNP Numbers (Release 35.0)	2-19
2.23	384 Million LNP Records (Release 39.0, ELAP 8.0)	2-20
2.23.1	Feature Control Requirements	2-20
2.23.2	Hardware Requirements	2-21
2.23.3	Limitations	2-22
2.24	500 SS7 Links (Release 21.0)	2-22
2.25	504 Million LNP Entries (Release 10.1)	2-23
2.25.1	Hardware Requirements	2-24
2.26	1100 TPS/DSM for ITU NP (Release 36.0)	2-24
2.27	2500 Routing Keys (IP7 Release 7.1)	2-25
2.28	4000 Routesets (Release 23.0)	2-26
2.29	5000 Routes (Release 26.1)	2-26
2.30	6000 Routesets (Release 29.0)	2-26
2.31	8,000 Routesets (Releases 31.8, 34.0)	2-27
2.32	10,000 Routesets (Release 43.0)	2-28
2.32.1	Feature Control Requirements	2-28
2.32.2	Hardware Requirements	2-28
2.33	40,000 GTT Capacity (Release 28.0) (IP7 Release 6.0)	2-28
2.34	50,000 GTT Capacity (Release 35.1)	2-28
2.35	65,535 Entries per Translation Type (Release 22.0)	2-29
2.36	150,000 GTT TPS and 75,000 EPAP TPS (Release 37.0)	2-29
2.37	Ability to Change System Required User Passwords (ELAP 9.0)	2-30
2.38	Ability to Change System Required User Passwords (EPAP 14.0)	2-31
2.39	Ability to Configure a Single EPAP Server (Release 16.2)	2-32
2.40	Additional DRA values for INP formatting (Release 43.0)	2-32
2.41	Additional Integrated Sentinel Support (Release 28.2)	2-33
2.42	Add GTT on SLIC IPSG [6500] (Release 46.5)	2-33
2.42.1	Hardware	2-34
2.43	Additional PDBI Provisioning Statistics on EPAP (EPAP 15.0)	2-34

2.44	Additional Subscriber Data (Release 40.0, EPAP 12.0)	2-35
2.44.1	Feature Control Requirements	2-36
2.45	Administrable SLTMs (Release 20.0)	2-36
2.46	Advanced GT Modification (Release 38.0)	2-36
2.46.1	Feature Control Requirements	2-36
2.46.2	Hardware Requirements	2-37
2.46.3	Limitations	2-37
2.47	AIN LNP Message Support (Release 46.0)	2-37
2.48	AINF Applique (Release 21.0)	2-37
2.49	AINPQ Service Portability (Release 41.1)	2-38
2.50	Alarm Enhancements (Release 26.0)	2-38
2.51	Allow a Mated Application to Work as Primary-Secondary and Secondary-Primary (Release 22.0)	2-38
2.52	Allow MOBR Exception Routes to Adjacent Point Codes (Release 44.0)	2-41
2.52.1	Feature Control Requirements	2-41
2.52.2	Limitations	2-41
2.53	Allowed Affected Destination Field Screen (Release 22.0)	2-42
2.54	Allowed CDPA Screen on SCCP Management Format ID (Release 22.0)	2-44
2.55	Alternate Command Keywords (Release 20.0)	2-44
2.56	ANSI G-Flex Support at 1700 TPS per DSM (Release 30.3)	2-45
2.57	ANSI support for RANDOM SLS on Incoming Linkset (Release 40.0)	2-45
2.57.1	Feature Control Requirements	2-45
2.58	ANSI-41 AnalyzedInformation Query - no EPAP/ELAP (Release 42.0)	2-46
2.58.1	Feature Control Requirements	2-46
2.58.2	Hardware Requirements	2-46
2.59	ANSI-41 INP Query (AINPQ) (Release 36.0)	2-46
2.60	ANSI-41 Mobile Number Portability (A-Port™) (Release 36.0)	2-49
2.61	ANSI-ITU-China SCCP Conversion (Release 31.3)	2-51
2.62	ANSI/ITU MTP Gateway (Release 20.0)	2-52
2.63	ANSI/ITU SCCP and TCAP Conversion (Optional) (Release 22.2)	2-55
2.64	ANSI/ITU SCCP and TCAP Conversion (Release 24.0)	2-55
2.65	ANSI/ITU SCCP Conversion – Optional Conversion of CgPA when Crossing ITU-x Domains (Release 45.0)	2-56
2.66	ANSI/ITU Translation (Release 35.0)	2-56
2.67	A-Port Circular Route Prevention (Release 41.1)	2-57
2.67.1	Feature Control Requirements	2-57
2.67.2	Hardware Requirements	2-57
2.67.3	Limitations	2-57
2.68	ASM Obsolescence (Release 31.6)	2-57
2.69	ATINP Service Portability (Release 41.1)	2-58
2.70	ATI Number Portability Query (ATINP) (Release 39.2)	2-58
2.70.1	Feature Control Requirements	2-59

2.70.2	Hardware Requirements	2-59
2.70.3	Limitations	2-59
2.71	Auto Point Code Recovery (Releases 35.6, 37.5)	2-59
2.71.1	Feature Control Requirements	2-60
2.71.2	Hardware Requirements	2-60
2.71.3	Limitations	2-60
2.72	Automatic PDB and RTDB Backup (EPAP 7.0)	2-61
2.73	Automatic PDB Export Enhancement (EPAP 9.0)	2-63
2.74	Backup Provisioning Network Interface (Release 29.0)	2-64
2.75	Calling Name Conversion Facility (CNCf) (Release 23.1)	2-64
2.76	Calling Name Conversion Facility (CNCf) with Redirect Capability (Release 24.0)	2-77
2.77	CDU for DSM (Release 26.05)	2-80
2.78	CgPA GWS Routing Indicator Enhancement (Release 31.3)	2-81
2.79	Change Default ATM CLP Bit for Data Cells from 1 to 0 (Release 31.3)	2-81
2.80	Changeover and Changeback Procedure for Processor Outage and LIN (Release 21.0)	2-82
2.81	Cluster Routing and Management Diversity (Release 21.0)	2-82
2.82	Command Class Management (Release 29.0)	2-86
2.83	Command Output Changes (Release 22.0)	2-87
2.84	Command to perform migration of IPLIM to IPSG (Release 42.0)	2-88
2.84.1	Hardware Requirements	2-88
2.85	Configurable SCTP Heartbeat Timer (Release 46.0)	2-88
2.86	Configurable Timer for link NO-DATA Condition (Release 37.7, 39.0)	2-88
2.87	Configuring the Frequency of RST Messages on Low Priority Routes (Release 22.0)	2-89
2.88	Configuring the Unauthorized Use Warning Message (Release 22.0)	2-90
2.89	Congestion Abatement Reporting (Release 21.0)	2-93
2.90	Consistent Command Response Conversion (Releases 22.0, 24.0)	2-94
2.91	Core Software Version Updates (EPAP 16.0)	2-95
2.92	Cost Factor on Routing (Release 20.0)	2-95
2.93	CRP for SRIs without HomeRN (Release 42.0)	2-95
2.93.1	Feature Control Requirements	2-96
2.94	CSPC Increase in Groups (Release 34.0)	2-96
2.95	Customer Definable Alarms (Release 20.0)	2-96
2.96	CutAndPaste parameter in Connect response to INP IDP Query (Release 42.0)	2-97
2.96.1	Feature Control Requirements	2-97
2.97	Database Integrity Enhancements (Release 20.0)	2-97
2.98	Database Management Command Functions (Release 20.0)	2-97
2.99	Database Transport Access (DTA) (Release 20.0)	2-99
2.100	DEIR on SLIC Network Redundancy Enhancement (Release 46.4)	2-99
2.100.1	Hardware	2-100
2.101	Delay Vs. Throughput (IP7 Release 5.0)	2-100

2.102	Digit Action to Delete Country Code when Present and Prefix with Database Entity (Release 44.0)	2-105
2.103	DigitAction Expansion (Releases 31.11, 34.0)	2-105
2.104	Disallow Simultaneous Logins Sessions with the Same User ID (Release 21.0)	2-106
2.105	Discard TFC Traffic (Release 34.0)	2-107
2.106	Disk Coherency Tests (Release 20.0)	2-107
2.107	Disk Copy Fixed to Fixed (Release 20.0)	2-107
2.108	Display Inhibited Alarms (Release 29.0)	2-107
2.109	Dual ExAP Configuration (Release 45.0)	2-108
2.109.1	Feature Control Requirements	2-108
2.109.2	Hardware	2-108
2.110	E1 Administration and Alarms (Release 26.3)	2-109
2.111	E1 ATM High Speed Link (Release 28.1) (IP7 Release 6.0)	2-111
2.112	E1/T1 MIM on EPM (E5-E1T1 Card) (Release 35.0)	2-112
2.113	E1/T1 MIM on EPM (Release 35.1)	2-114
2.114	E1/T1 Multi-Channel Interface Module (Release 28.0) (IP7 Release 6.0)	2-115
2.115	E5-APP-B Card (ELAP 10.0)	2-116
2.116	E5-APP-B Card (EPAP 15.0)	2-116
2.117	E5-ATM Card (Release 38.0)	2-116
2.117.1	Feature Control Requirements	2-117
2.117.2	Hardware Requirements	2-117
2.117.3	Limitations	2-117
2.118	E5-ATM-B (Release 44.0)	2-117
2.118.1	Feature Control Requirements	2-117
2.119	E5-E1T1-B (Release 45.0)	2-118
2.119.1	Hardware Requirements	2-118
2.120	E5-E1T1-B Increased Throughput (Release 46.0)	2-119
2.121	E5-ENET SLAN to ECAP (Release 41.1)	2-119
2.122	E5-ENET-B (Release 44.0)	2-119
2.122.1	Feature Control Requirements	2-120
2.123	E5-ENET-B IPSG High Throughput (Release 44.0)	2-120
2.123.1	Feature Control Requirements	2-121
2.124	E5-MCPM-B (Release 44.0)	2-121
2.124.1	Feature Control Requirements	2-121
2.124.2	Hardware Requirements	2-122
2.125	E5-OAM Cards (E5-MASP and E5-MDAL) (Release 40.1)	2-122
2.125.1	Feature Control Requirements	2-122
2.125.2	Hardware Requirements	2-122
2.126	E5-OAM Integrated GLS (Release 44.0)	2-122
2.126.1	Feature Control Requirements	2-123
2.126.2	Hardware Requirements	2-123

2.127	E5-OAM Integrated Measurements (Release 42.0)	2-123
2.127.1	Feature Control Requirements	2-123
2.127.2	Hardware Requirements	2-124
2.128	E5-OAM SNMP Support (Release 45.0)	2-124
2.128.1	Feature Control Requirements	2-124
2.128.2	Hardware Requirements	2-124
2.129	E5-SLAN Throughput Throttle for ECAP Connection (Release 41.1)	2-124
2.130	E5-SM4G Card (Release 37.0)	2-125
2.131	E5-SM8G-B (Release 44.0)	2-126
2.131.1	Feature Control Requirements	2-126
2.131.2	Hardware Requirements	2-127
2.132	EAGLE Alarm Modifications for Synchronization with Harris (Release 31.5)	2-127
2.133	EAGLE Collector Application Processor (ECAP) on the T1200 Platform (ECAP 41.1)	2-128
2.133.1	Hardware Requirements	2-129
2.134	EAGLE Database Increase to 480M DN + 600M Flexible IMSI/IMEI Allocation (Release 46.7)	2-130
2.135	Eagle Eyes OAM Friendly Commands (Release 46.0)	2-131
2.136	EAGLE Frame Power Budget Alarm (Release 35.0)	2-131
2.137	EAGLE Initiated OAP User Interface (Release 24.0)	2-132
2.138	EAGLE Measurement Reports (Release 20.0)	2-133
2.139	EAGLE MNP Data Base support for 240M DN (Release 46.3)	2-133
2.139.1	Hardware	2-134
2.140	EAGLE OA&M IP Security Enhancements (EAGLE Releases 30.0, 30.2, IP7 Secure Gateway Release 8.0)	2-134
2.141	EAGLE OA&M Password Security Enhancements (Release 42.0)	2-140
2.141.1	Feature Control Requirements	2-140
2.142	EAGLE - Obsolete OAM Measurements (Release 46.3)	2-140
2.143	EAGLE Support for Integrated Sentinel (Release 28.0)	2-141
2.144	EAGLE Query Server on COTS Hardware (Release 1.0)	2-141
2.144.1	Hardware	2-142
2.145	EAGLE Query Server Support EPAP (Release 1.0)	2-142
2.146	EDCM Support (IP7 Release 4.0)	2-142
2.147	EIR Expansion 50K to 100K (Release 45.0)	2-143
2.148	EIR Expansion of IMEI Block from 50k to 100k (EPAP 15.0)	2-143
2.149	EIR S13/S13' Interface Support (Release 45.1)	2-143
2.149.1	Feature Control Requirements	2-143
2.149.2	Hardware Requirements	2-143
2.150	ELAP Backup Enhancements (ELAP 10.0)	2-144
2.151	ELAP Logging Enhancements (ELAP 10.0)	2-145
2.152	ELAP Network Address Translation (NAT) (EAGLE Release 30.0/IP7 Secure Gateway Release 8.0)	2-147

2.153	ELAP Support for more than Nine E5-SM4G Cards for the LNP Feature (ELAP 9.0)	2-152
2.153.1	Feature Control Requirements	2-152
2.154	ENUM Mobile Number Portability and Tier One Address Resolution (Release 46.2)	2-153
2.154.1	Hardware	2-153
2.155	Embedded OAP (Release 24.0)	2-153
2.156	End Office Support (IP7 Release 5.0)	2-165
2.157	Enhance GSM MAP Screening to add TC_Continue and End (Release 35.1)	2-166
2.158	Enhance RTRV-LOG (Release 31.3)	2-167
2.159	Enhanced Bulk Download (Release 25.0)	2-167
2.160	Enhanced Database Status Reports (Release 20.0)	2-171
2.161	Enhanced GPL Management (Release 25.0)	2-171
2.162	Enhanced GSM MAP Screening (Release 31.4, 39.2)	2-171
2.162.1	Feature Control Requirements	2-172
2.162.2	Hardware Requirements	2-172
2.162.3	Limitations	2-172
2.163	Enhanced GTT (Release 26.0)	2-172
2.164	Enhanced Link Diagnostics (Release 22.0)	2-173
2.165	Enhanced Load Distribution (Release 21.0)	2-173
2.166	Enhanced Routing Key Support (IP7 Release 2.0)	2-173
2.167	Enhanced Software Loading (Release 20.0)	2-176
2.168	Enhanced STC Card Performance (Release 35.0)	2-176
2.169	Enhancement to Backup TFR/TCR Procedures (Release 21.0)	2-177
2.170	Enhancement to GSM ATI Query (Release 45.0)	2-177
2.170.1	Feature Control Requirements	2-177
2.171	Enhancement to GTT Failure Messages (Release 25.0)	2-177
2.172	Enhancement to the Prepaid IDP Query Relay Feature (Release 39.0)	2-179
2.172.1	NPP Modifications	2-179
2.172.2	Feature Control Requirements	2-179
2.172.3	Hardware Requirements	2-180
2.172.4	Limitations	2-180
2.173	Enhancements to GWS Reject Messages (Release 25.0)	2-180
2.174	Enlarged LNP SPID and NPANXX Support (Release 24.0)	2-182
2.175	ENT-CARD Enhancement (Release 46.0)	2-182
2.176	Entering a Global Title Translation to a Non-Mated Application without Adding the Application as Mated Application (Release 22.0)	2-182
2.177	ENUM Enhancement to update ENUMPROF table	2-183
2.178	ENUM on SLIC Network Redundancy Enhancement (Release 46.5)	2-184
2.178.1	Hardware	2-184
2.179	EOAP/OAP Support of HSOP Protocol (Release 28.0)	2-184
2.180	EPAP 2.0 Alarm Migration from ELAP (EAGLE 28.0)	2-186
2.181	EPAP Automated Database Recovery (EPAP 7.0)	2-186

2.182	EPAP Command Response Enhancement (Release 31.6)	2-187
2.183	EPAP DN Block Capacity Increase (Release 46.0)	2-187
2.184	EPAP Expansion to 480M Database Entries (Release 16.1)	2-187
2.184.1	Hardware	2-188
2.185	EPAP Feed to External Query Server (EPAP 16.0)	2-188
2.186	EPAP on T1200 Application Server (EPAP 13.0)	2-188
2.187	EPAP PDB-RTDB Level Threshold (Release 31.6)	2-189
2.188	EPAP Performance on E5-APP-B (EPAP 15.0)	2-189
2.189	EPAP Provisioning Blacklist (EPAP 7.0)	2-189
2.190	EPAP Provisioning Performance Enhancements (Release 29.0)	2-190
2.191	EPAP RTDB Level Auto Refresh (Release 31.6)	2-191
2.192	EPAP Security Enhancements (Release 29.0)	2-192
2.193	EPAP Support for HTTPS on GUI (EPAP 9.0)	2-193
2.194	EPAP Support for SSH on PDBI (EPAP 9.0)	2-193
2.195	EPAP Support of EAGLE's ITU Duplicate Point Code (Release 29.0)	2-195
2.196	EPAP Update Validation (EPAP 7.0)	2-196
2.197	EPAP with TPD 1.1 (Release 31.6)	2-196
2.198	EPAP/ELAP 2.0 Security and UI Enhancements (Release 28.0)	2-197
2.199	EPM-B Based Cards(Release 44.0)	2-197
2.199.1	Hardware Requirements	2-197
2.200	Equipment Identity Register (EIR) (Release 31.0)	2-198
2.201	Error Message Reporting Enhancement (Release 21.0)	2-198
2.202	Ethernet B Interface for IPGWx and IPLIMx (Release 28.1, IP7 Release 6.0)	2-199
2.203	Expanded Terminal Output Groups (Release 31.3)	2-200
2.204	Extended Bus Interface (Release 20.0)	2-200
2.205	Extended EPAP DN Block Capacity (EPAP 16.0)	2-200
2.206	Extension Shelf Backplane (Release 23.0)	2-200

3 Features F - K

3.1	Fall-back to GTT after LNP MR Service (Release 43.0)	3-1
3.1.1	Feature Control Requirements	3-1
3.1.2	Hardware Requirements	3-1
3.2	False Link Congestion Management (Release 21.0)	3-1
3.3	EAGLE 5 ISS Fast Copy (Release 40.1)	3-2
3.3.1	Feature Control Requirements	3-2
3.3.2	Hardware Requirements	3-2
3.3.3	Limitations	3-3
3.4	Feature Control Mechanism (IP7 Release 3.0)	3-3
3.5	File Complete Alarm after Completion of PDB Export (EPAP 16.0)	3-3
3.6	File Transfer Utility (Release 20.0)	3-3

3.7	Flash Memory Management (Release 23.0)	3-3
3.8	Flexible GTT Load-Sharing (Release 35.0)	3-4
3.9	Flexible Intermediate GTT Load-Sharing (Release 34.2)	3-5
3.10	Flexible Link set Optional Based Routing (Release 41.0)	3-11
3.10.1	Feature Control Requirements	3-12
3.10.2	Hardware Requirements	3-12
3.11	Flexible Point Code Formatting (Release 26.0)	3-12
3.12	FLOBR Enhancements (Release 42.0)	3-13
3.12.1	Feature Control Requirements	3-13
3.12.2	Hardware Requirements	3-13
3.13	Force Change of an Assigned Password at First Login (Release 21.0)	3-14
3.14	FTP Retrieve and Replace (Release 29.0) (IP7 Release 7.0)	3-14
3.15	FTRA 2.1 Compatibility with EAGLE 31.3 (Release 31.3)	3-16
3.16	FTRA 2.2 Compatibility with EAGLE 31.6 (Release 31.6)	3-17
3.17	FTRA Dependencies on EAGLE (Release 46.0)	3-17
3.18	Gateway Screening Stop Action - De-encapsulate (Release 46.0)	3-17
3.19	Gateway Screening Stop Action - Duplicate and Route (Release 46.0)	3-17
3.20	Gateway Threshold Exceeded Notification (Release 22.0)	3-17
3.21	General Purpose Service Module-II (GPSM-II) for MCAP Slot (Release 28.0)	3-19
3.22	G-Flex C7 Relay (Release 26.2)	3-20
3.23	G-Flex MAP Layer Routing (Release 38.0)	3-21
3.23.1	Feature Control Requirements	3-22
3.23.2	Hardware Requirements	3-22
3.23.3	Limitations	3-22
3.24	G-Flex MAP Layer Routing (Release 43.1)	3-22
3.25	G-Flex MAP Layer Routing support for ATI using MSISDN (Release 42.0)	3-23
3.25.1	Feature Control Requirements	3-23
3.26	G-Flex MLR Support for Additional OpCodes (Release 43.0)	3-23
3.26.1	Feature Control Requirements	3-24
3.26.2	Hardware Requirements	3-24
3.27	Global Option for Connect on INP Query Response (Release 35.0)	3-24
3.28	Global Title Modification (Release 28.1) (IP7 Release 6.0)	3-24
3.29	Global Title Translation (GTT) (Release 20.0)	3-25
3.30	G-Port MNP (Release 26.2)	3-25
3.31	G-Port MNP Circular Route Prevention (Release 28.1)	3-25
3.32	G-Port SRI Query for Prepaid (Release 35.2)	3-26
3.33	G-Port SRI Query for Prepaid Service Portability (Release 41.1)	3-27
3.34	GR-376 Interface (Release 26.0)	3-27
3.35	Group Ticket Voucher (Release 23.0)	3-27
3.36	Group Ticket Voucher for SCCP Cards (Release 27.0)	3-30
3.37	GSM MAP Screening (Release 26.1)	3-32

3.38	GSM MAP Screening Duplicate/Forward (Release 29.0)	3-33
3.39	GSM MAP SRI Redirect to Serving HLR (Releases 31.11, 34.0)	3-34
3.40	GTT Actions (Release 42.0)	3-34
3.40.1	Feature Control Requirements	3-36
3.40.2	Hardware Requirements	3-36
3.40.3	Limitations	3-36
3.41	GTT Actions to Trigger Services (Release 46.0)	3-37
3.42	GTT by TT Measurements and GR-376 Enhancements (Release 26.0)	3-37
3.43	GTT Error Reporting Enhancements (Release 21.0)	3-39
3.44	GTT Loadsharing between ITU Network Types (Release 40.1)	3-40
3.45	GTT Loadsharing to 32 Destinations (Release 36.0)	3-40
3.46	GTT Loadsharing with Alternate Routing Indicator (Release 40.1)	3-41
3.46.1	Feature Control Requirements	3-41
3.46.2	Limitations	3-41
3.47	GTT Table Increase (Release 29.0)	3-41
3.48	GTT UIM 21 Digit Length Enhancement (Release 29.0)	3-42
3.49	GTTSET Table Increase (Release 46.0)	3-42
3.50	GWS Error Reporting Enhancement (Release 21.0)	3-43
3.51	GWS Stop Action for MTP Routed Messages (Release 41.1)	3-43
3.51.1	Feature Control Requirements	3-44
3.52	Hardware Maintenance Phase for E5-ATM Card (Release 46.6)	3-44
3.53	Hardware Maintenance Phase for E5-E1T1 Card (Release 46.6)	3-45
3.54	Hardware Maintenance Phase for E5-ENET Card (Release 46.6)	3-45
3.55	Hardware Maintenance Phase for E5-IPSM Cards (Release 46.5)	3-45
3.56	Hardware Maintenance Phase for E5-SM4G Cards (Release 46.6)	3-45
3.57	Hardware Maintenance Phase for E5-TSM Card (Release 46.6)	3-46
3.58	Hardware Maintenance Phase for EAGLE ATM Cards (Release 46.0)	3-46
3.59	Hardware Maintenance Phase for EAGLE DCM cards (Release 46.0)	3-46
3.60	Hardware Maintenance Phase for EAGLE DSM cards (Release 46.0)	3-46
3.61	Hardware Maintenance Phase for EAGLE E1/T1 MIM cards (Release 46.0)	3-46
3.62	Hardware Maintenance Phase for EAGLE EDCM cards (Release 46.0)	3-47
3.63	Hardware Maintenance Phase for EAGLE EDCM cards used for SIGTRAN (Release 45.0)	3-47
3.64	Hardware Maintenance Phase for EAGLE EDCM-A cards (Release 46.0)	3-47
3.65	Hardware Maintenance Phase for EAGLE HIPR Cards (Release 46.1)	3-47
3.66	Hardware Maintenance Phase for EAGLE HMUX cards (Release 46.0)	3-48
3.67	Hardware Maintenance Phase for EAGLE IPSM cards (Release 45.0)	3-48
3.68	Hardware Maintenance Phase for EAGLE MCPM cards (Release 46.0)	3-48
3.69	Hardware Maintenance Phase for EAGLE MPL cards (Release 46.0)	3-48
3.70	Hardware Maintenance Phase for HC-MIM Card (Release 46.6)	3-49
3.71	Hardware Maintenance Phase for OAM cards (TDM, GPSM-II, MDAL) (Release 45.0)	3-49

3.72	Hardware Maintenance Phase for EAGLE TSM cards used for Gateway Screening (Release 45.0)	3-49
3.73	Hex Digit Support for GTT (Release 35.3)	3-49
3.74	High Capacity Multi-Channel Interface Module (HC MIM) (Releases 33.0 34.0)	3-52
3.75	High Speed IMT Packet Router (HIPR) (Releases 33.0 34.0)	3-54
3.76	High-speed IMT Packet Router (HIPR2) (Release 42.0)	3-55
3.76.1	Feature Control Requirements	3-55
3.76.2	Hardware Requirements	3-55
3.77	High Speed Master Timing (Release 26.0)	3-56
3.78	High-Speed Multiplexer (HMUX) (Release 27.2)	3-61
3.79	Holdover BITS Clock Support (Release 21.0)	3-63
3.80	HomeSMSC Match with Digits Option for Portability Check for Mobile Originated SMS (Release 39.0)	3-63
3.80.1	Feature Control Requirements	3-63
3.80.2	Hardware Requirements	3-63
3.80.3	Limitations	3-63
3.81	Hybrid INP/IDP Relay Service (Release 43.0)	3-63
3.81.1	Feature Control Requirements	3-64
3.82	IAR NP Service Portability (Release 41.1)	3-64
3.83	Idle Terminal Port Logout (Release 21.0)	3-64
3.84	IDP A-Party Blacklist (Release 41.1)	3-65
3.84.1	Feature Control Requirements	3-66
3.84.2	Limitations	3-66
3.85	IDP A-Party Blacklist (EPAP 13.0)	3-66
3.86	IDP A-Party Routing (Release 41.1)	3-68
3.86.1	Feature Control Requirements	3-68
3.87	IDP Relay Support for CAP v3 IDP-SMS (Release 40.0)	3-69
3.88	IDP Screening for PrePaid (Release 34.3)	3-69
3.89	IDP Service Key Routing (Release 41.1)	3-70
3.89.1	Feature Control Requirements	3-70
3.90	IDPR Intl Normalization (Release 37.10)	3-70
3.90.1	Feature Control Requirements	3-71
3.90.2	Hardware Requirements	3-71
3.90.3	Limitations	3-71
3.91	IDPR TON Mapping for CdPN BCD Format (Release 44.0)	3-71
3.92	IETF M3UA for "A" Link Connectivity (Release 28.1)	3-71
3.93	IETF M3UA Support including IETF SUA (IP7 Release 5.0)	3-72
3.94	IETF Protocol Update (Release 28.1) (IP7 Release 6.0)	3-72
3.95	IETF SCTP for "A" Link Connectivity (Release 28.1)	3-73
3.96	IETF SCTP Support (IP7 Release 5.0)	3-74
3.97	IETF SUA for "A" Link Connectivity (Release 28.1)	3-75
3.98	IETF SUA Support (Release 34.0)	3-76

3.99	Implementation of SNMP Agent (IP7 Release 2.0)	3-76
3.100	Improved Routing Management (Release 20.0)	3-78
3.101	IMSI Change with Single PDBI Command (EPAP 16.0)	3-79
3.102	IMSI Range Logic Support (Release 46.0)	3-79
3.103	IMT Fault Isolation (Release 22.0)	3-79
3.104	IMT Subsystem Alarms (Release 20.0)	3-80
3.105	INAP-based Number Portability (INP) (Release 26.05)	3-80
3.106	Include optional CUG parameter in SRI_ACK (Release 42.0)	3-80
3.106.1	Feature Control Requirements	3-81
3.107	Incoming and Outgoing Linkset Name Added to the SLAN report for ECAP (ECAP 40.1)	3-81
3.108	Increase E1T1 Link counts [3HSL 96LSL] on SLIC (Release 46.6)	3-82
3.108.1	Hardware	3-82
3.109	Increase Gateway Screening Screen Sets to 255 (Release 22.0)	3-83
3.110	Increase GTT Entries per TT to 200,000 (Release 29.0)	3-84
3.111	Increase in Time Zones (EAGLE Release 30.0/IP7 Secure Gateway Release 8.0)	3-84
3.112	Increase IPSG SIGTRAN connections (Release 46.5)	3-86
3.113	Increase IPSG TPS [10k] on SLIC (Release 46.4)	3-86
3.114	Increase IPSG TPS [10k] on SLIC (Release 46.4)	3-86
3.115	Increase IP-RTE Table to 2048 Entries (Release 45.0)	3-86
3.116	Increase LNP DB Capacity (504M) (Release 46.3)	3-87
3.117	Increase System-Wide IP Signaling Connections (Release 31.6)	3-87
3.118	Increase System-Wide IPGWx TPS (Release 31.6)	3-87
3.119	Increase the number of entries in Vendor Prefix table (Release 46.4)	3-88
3.120	Increase the Number of Mated Application Entries (Release 22.0)	3-88
3.121	Increase the number of supported Service Module cards per node(Release 46.5)	3-89
3.122	Increased GTT Transactions (Release 21.0)	3-89
3.123	Increased Linkset Capacity (Release 28.0)	3-89
3.124	Increasing the Size of the Service Provider ID Table (Release 23.2)	3-90
3.125	Info Analyzed Relay (Release 41.1)	3-90
3.125.1	Feature Control Requirements	3-91
3.126	INP Circular Route Prevention (Release 41.1)	3-91
3.126.1	Feature Control Requirements	3-91
3.127	INP, G-port, and ATI NP Enhancements for Support of ROP (Release 41.1)	3-92
3.128	INP, G-Port, and ATINP Enhancements for Support of ROP (EPAP 13.0)	3-92
3.129	INP Number Normalization (Release 26.3)	3-93
3.130	INP Service Portability (Release 41.1)	3-93
3.131	Integrated Monitoring for E5-E1T1 (Release 35.1)	3-93
3.132	Integrated SE-HSL Data Feed at 1 Erlang (Release 37.7, 39.0)	3-94
3.133	Interim Global Title Modification (IP7 Release 2.2)	3-94
3.134	Intermediate GTT Loadsharing (Release 28.1)	3-94

3.135	Intra Network Number Portability (Release 46.1)	3-95
3.136	Intrusion Alert (Release 21.0)	3-95
3.137	IP Signaling Gateway (IPSG) (Release 38.0)	3-96
3.137.1	Feature Control Requirements	3-97
3.137.2	Hardware Requirements	3-97
3.137.3	Limitations	3-97
3.138	IP Signaling Serviceability (Release 35.0)	3-97
3.139	IP User Interface: Telnet Support (Release 29.0) (IP7 Release 7.0)	3-98
3.140	IP7 Internationalization (IP7 Release 4.0)	3-99
3.141	IP7 Transport Feature (Release 26.1)	3-100
3.142	IPGWx Congestion Enhancement (Release 35.1)	3-100
3.143	IPGWx Data Feed (Release 35.0)	3-101
3.144	IPGWx Data Feed (Release 35.1)	3-103
3.145	IPGWx TPS Control (Release 31.6)	3-103
3.146	IPLIM Protocol Support Enhancement (Release 28.1) (IP7 Release 6.0)	3-104
3.147	IPLIMx Data Feed (Release 35.0)	3-104
3.148	IPLIMx to 8 Points (Release 29.1) (IP7 Release 7.1)	3-106
3.149	IPLIMx/IPGWx on EPM (E5-ENET Card) (Release 35.0)	3-107
3.150	IPLIMx/IPGWx on EPM (Release 35.1)	3-110
3.151	IPMX/MCAP/TDM Replacement (EAGLE Release 30.0/IP7 Secure Gateway Release 8.0)	3-110
3.152	IP-SCP with LNP Capability (IP7Releases 1.0, 2.0)	3-111
3.153	IPS Application on E5-ENET-B (Release 44.0)	3-111
3.153.1	Feature Control Requirements	3-111
3.154	IPS GPL on E5 Assembly (Release 37.5)	3-112
3.154.1	Feature Control Requirements	3-112
3.154.2	Hardware Requirements	3-112
3.154.3	Limitations	3-112
3.155	IPv6 support on EPAP (Release 16.1)	3-112
3.155.1	Hardware	3-113
3.156	IS41 GSM Migration (Release 36.0)	3-113
3.157	IS41 GSM Migration Support for Relaying SRI_SM to Default SMSC (Release 41.1)	3-116
3.157.1	Feature Control Requirements	3-117
3.157.2	Hardware Requirements	3-117
3.158	IS-41 to GSM Migration (EAGLE Release 30.0/IP7 Secure Gateway Release 8.0)	3-117
3.159	ISCC Interface Loopback Test (Release 22.0)	3-117
3.160	ISUP Message Type Screening (EAGLE Release 30.0/IP7 Secure Gateway Release 8.0)	3-119
3.161	ISUP Normalization Administration (IP7 Release 5.0)	3-119
3.162	ISUP Normalization in the IP7 SG (IP7 Release 4.0)	3-120
3.163	ISUP NP with EPAP (Releases 31.11, 34.0)	3-121

3.164	ISUP-Over-IP Gateway for Connectivity to IP-SEPs (IP7 Release 1.0)	3-121
3.165	ITU DTA (a.k.a. ITU Triggerless Message Screening) (Release 31.6)	3-123
3.166	ITU Duplicate Point Code Routing (Release 26.05)	3-124
3.167	ITU Gateway Measurements Enhancements (PR19536) (Release 26.05)	3-125
3.168	ITU International and National Spare Point Code (Release 34.0)	3-127
3.169	ITU MTP Restart (Release 26.0)	3-129
3.170	ITU SLS Enhancements (Release 26.0)	3-130
3.171	ITU TCAP LRN Query (Release 40.0)	3-131
3.171.1	Feature Control Requirements	3-131
3.171.2	Hardware Requirements	3-131
3.172	ITUN-ANSI SMS Conversion (Release 37.0)	3-131
3.173	ITU-TFR Procedure (Release 26.1)	3-132
3.174	ITU/ANSI Conversion SLS Enhancement (Release 45.0)	3-133
3.175	J7 Feature (Release 45.1)	3-133
3.175.1	Feature Control Requirements	3-134
3.176	J7/TTC for J1-LSL Low Speed Link Support (Release 46.0)	3-134
3.177	KSR Terminal Feature (Release 20.0)	3-134

4 Features L - O

4.1	Large BICC MSU Support for IP Signaling (Release 37.0)	4-1
4.2	Large MSU Support for IP Signaling (Release 42.0)	4-2
4.2.1	Feature Control Requirements	4-2
4.2.2	Hardware Requirements	4-3
4.3	Large System (Release 27.2)	4-3
4.4	Large System—Phase 2 (Release 28.0)	4-3
4.5	Large System (Phase 3)—1500 Links (Release 29.0)	4-4
4.6	Last 10 Command Retrieval (EAGLE Release 30.0/IP7 Secure Gateway Release 8.0)	4-5
4.7	Link Failure Status Information (Release 22.0)	4-6
4.8	Link Fault Sectionalization (Release 21.0)	4-10
4.9	Link Maintenance Enhancements/LFS Increase for MPL-T and MIM (Release 31.3)	4-14
4.10	Link Status Reporting (Release 21.0)	4-14
4.11	Linkset ID to Measurements Report (EAGLE Release 30.0/IP7 Secure Gateway Release 8.0)	4-17
4.12	Linkset Name Increase—ANSI/ITU (EAGLE Release 30.0/IP7 Secure Gateway Release 8.0)	4-17
4.13	Linkset Restricted Support (Release 31.9)	4-18
4.14	Linkset Restricted Support (Release 34.0)	4-20
4.15	LNP 96 Million TNS—EAGLE 5 (EAGLE Release 30.0, IP7 Secure Gateway Release 8.0)	4-21
4.16	LNP AIN Query Enhancement (PR28376) (Release 26.0)	4-31

4.17	LNP Measurements Enhancements (Release 25.0)	4-31
4.18	LNP Message Relay Enhancement (PR28810) (Release 26.0)	4-34
4.19	LNP Response to STPLAN (PR28660) (Release 26.0)	4-35
4.20	LNP Short Message Service (Release 28.2)	4-36
4.21	LNP—10 Digit Telephone Number Subscription Commands (Release 22.0)	4-37
4.22	LNP—Allow Subsystem Command (Release 22.0)	4-38
4.23	LNP—Automatic Call Gapping (Release 22.0)	4-38
4.24	LNP—Automatic Call Gapping Commands (Release 22.0)	4-38
4.25	LNP—Call Completion to Ported Number (CCPN) (Release 22.0)	4-39
4.26	LNP—Change Database Command (Release 22.0)	4-39
4.27	LNP—Changes to Existing Commands (Release 22.0)	4-40
4.28	LNP—clr-disk-stats Command (Release 22.0)	4-41
4.29	LNP—Degraded Mode (Release 22.0)	4-41
4.30	LNP—Destination Point Code Exception Report (Release 23.1)	4-42
4.31	LNP—disp-disk-stats Command (Release 22.0)	4-42
4.32	LNP—EAGLE LNP Configuration (Release 22.0)	4-43
4.33	LNP—Element Manager System (EMS) (Release 22.0)	4-44
4.34	LNP—Enhanced Global Title Translation Routing Services (Release 22.0)	4-45
4.35	LNP—Inhibit Subsystem Command (Release 22.0)	4-46
4.36	LNP—Impact of LNP on Other Features (Release 22.0)	4-46
4.37	LNP—Location Routing Number Commands (Release 22.0)	4-46
4.38	LNP—Mapping LNP Translation Type Commands (Release 22.0)	4-47
4.39	LNP—Measurements (Release 22.0)	4-47
4.40	LNP—Message Relay (Release 22.0)	4-50
4.41	LNP—MSU Trap and Trace Command (Release 22.0)	4-51
4.42	LNP—MTP and SCCP Management to Support LNP (Release 22.0)	4-51
4.43	LNP—New LNP Input and Output Groups (Release 22.0)	4-51
4.44	LNP—New Unsolicited Alarm Messages (UAMs) (Release 22.0)	4-52
4.45	LNP—New Unsolicited Information Messages (UIMs) (Release 22.0)	4-53
4.46	LNP—NPANXX Commands (Release 22.0)	4-54
4.47	LNP—Query Routed as Final Global Title Translation (Release 22.0)	4-54
4.48	LNP—Query Routed as Non-Final Global Title Translation (Release 22.0)	4-58
4.49	LNP—Report LNP Status Command (Release 22.0)	4-59
4.50	LNP—Rerouting Messages for the Local Subsystem (Release 22.0)	4-59
4.51	LNP—Retrieve LNP Database Time Stamp Command (Release 22.0)	4-60
4.52	LNP—SCCP Management on the LIMs (Release 22.0)	4-60
4.53	LNP—Service Commands (Release 22.0)	4-63
4.54	LNP—Service Provider Commands (Release 22.0)	4-63
4.55	LNP—Split NPA Commands (Release 22.0)	4-63
4.56	LNP—Subsystem Application Commands (Release 22.0)	4-64
4.57	LNP—System Options Commands (Release 22.0)	4-64

4.58	LOCREQ Query Response (Release 42.0)	4-64
4.58.1	Feature Control Requirements	4-65
4.59	Login Failure Message (Release 21.0)	4-65
4.60	Login Success or Failure Tracking (Release 21.0)	4-65
4.61	Logout on Communications Failures (Release 22.0)	4-66
4.62	LRN Table Increase (Release 26.1)	4-67
4.63	M2PA on IPLIMx (Release 29.1) (IP7 Release 7.1)	4-67
4.64	M2PA RFC Support (Release 34.3)	4-69
4.65	M3UA Protocol Enhancements (EAGLE Release 30.0/IP7 Secure Gateway Release 8.0)	4-69
4.66	Make DB Split Feature and GFlex MAP Layer Routing Work With Each Other (Release 46.5)	4-70
4.67	Management of Unused User IDs (Release 21.0)	4-71
4.68	Managing deprecation of Java Applet plugin support from Browsers (Release 16.2)	4-71
4.69	Manual Deactivation of SRST Message (Release 21.0)	4-71
4.70	MAP Table Increase (Release 29.0)	4-72
4.71	Measurements Enhancements (Release 22.0)	4-72
4.72	Measurements Platform Filename with CLLI (Release 31.3)	4-73
4.73	Measurements Platform IP Security (Release 31.6)	4-73
4.74	Measurements Platform—Phase 1 (Release 28.0)	4-75
4.75	Message Flow Control Replacement for TVG (Release 44.0)	4-76
4.75.1	Feature Control Requirements	4-77
4.76	MFC for EROUTE (Release 44.0)	4-77
4.77	MFC for MTP3 (Release 44.0)	4-77
4.78	MFC for SCCP (Release 44.0)	4-77
4.79	MFC for SLAN (Release 44.0)	4-78
4.80	Miscellaneous Command Adjustments (Release 26.0)	4-78
4.81	Miscellaneous Command Adjustments (Release 26.1)	4-78
4.82	MO-Based GSM SMS NP (Release 37.5)	4-81
4.82.1	Options	4-81
4.82.2	Feature Control Requirements	4-81
4.82.3	Hardware Requirements	4-82
4.82.4	Limitations	4-82
4.83	MO-Based IS41 SMS NP (Release 37.5)	4-82
4.83.1	Options	4-82
4.83.2	Feature Control	4-83
4.83.3	Hardware Requirements	4-83
4.83.4	Limitations	4-83
4.84	MO SMS B-Party Routing (Release 39.1)	4-83
4.84.1	Feature Control Requirements	4-83
4.84.2	Hardware Requirements	4-84
4.84.3	Limitations	4-84

4.85	MO SMS Migration Enhancements (Release 40.0)	4-84
4.85.1	MO SMS IS41-to-GSM Migration	4-84
4.85.1.1	Feature Control Requirements	4-84
4.85.1.2	Hardware Requirements	4-84
4.85.2	Enhancements to Existing MO SMS Features	4-85
4.86	MO SMS NPP (Release 40.1)	4-85
4.86.1	Feature Control Requirements	4-86
4.86.2	Limitations	4-86
4.87	MO SMS Prepaid Intercept on B-Party (Release 39.1)	4-86
4.87.1	Feature Control Requirements	4-87
4.87.2	Limitations	4-87
4.88	MO SMS Service Portability (Release 41.1)	4-87
4.89	Move GLS to EPM (Release 40.0)	4-88
4.89.1	Feature Control Requirements	4-88
4.89.2	Hardware Requirements	4-88
4.90	MSISDN Truncation Support for G-Port (Release 31.6)	4-88
4.91	MT-Based GSM MMS NP (Release 38.0)	4-89
4.91.1	Feature Control Requirements	4-89
4.91.2	Hardware Requirements	4-89
4.91.3	Limitations	4-89
4.92	MT-Based GSM SMS NP (Release 38.0)	4-90
4.92.1	Feature Control Requirements	4-90
4.92.2	Hardware Requirements	4-91
4.92.3	Limitations	4-91
4.93	MT-Based IS41 SMS NP (Release 38.0)	4-91
4.93.1	Feature Control Requirements	4-91
4.93.2	Hardware Requirements	4-92
4.93.3	Limitations	4-92
4.94	MTP and other MRN Message Format Improvements (Release 21.0)	4-92
4.95	MTP Circular Route Detection (Release 21.0)	4-96
4.96	MTP Map Screening (Releases 31.7, 34.0)	4-98
4.97	MTP Messages for SCCP Applications (Release 36.0)	4-98
4.98	MTP Restart (Release 21.0)	4-100
4.99	MTP Routed GTT (Release 42.0)	4-103
4.99.1	Feature Control Requirements	4-103
4.99.2	Hardware Requirements	4-103
4.100	Multiple Capability Point Codes (Release 21.0)	4-103
4.101	Multiple Country Code Support for G-Port (Release 31.6)	4-104
4.102	Multiple Flash Download (Release 29.0)	4-105
4.103	Multiple IDP Relay Instances (Release 43.0)	4-105
4.103.1	Feature Control Requirements	4-106

4.104	Multiple LFS Tests (Release 26.0)	4-106
4.105	Multiple Linksets to Single Adjacent PC (Release 37.5)	4-108
4.105.1	Feature Control Requirements	4-109
4.105.2	Hardware Requirements	4-109
4.105.3	Limitations	4-109
4.106	Multiple Point Code Support (Release 26.05)	4-109
4.107	Multiple Routing Contexts (Release 34.0)	4-115
4.108	Multi-Port LIM (Release 27.1) (IP7 Release 6.0)	4-118
4.109	National Spare Network Indicator Support (Release 22.2)	4-120
4.110	National Spare Network Indicator Support (Release 24.0)	4-120
4.111	NEBS Compliance (Release 20.0)	4-121
4.112	Need to decode Multiple components in a TCAP message (Release 46.5)	4-121
4.113	Nested Cluster Routing (Release 26.0)	4-122
4.113.1	Nested Clusters and Cluster Members	4-122
4.113.2	Administration	4-123
4.113.3	General Requirements	4-124
4.113.4	Upgrade Considerations	4-133
4.114	Network Conversion Grouping Time Enhancement (Release 46.0)	4-133
4.115	Network Routing (Release 26.0)	4-133
4.115.1	Types of Routing Strategies Available	4-134
4.115.2	Applications	4-134
4.115.3	MTP Requirements	4-135
4.116	Network Security Enhancements (Release 29.0)	4-139
4.117	Network Surveillance Enhancements (Release 28.0)	4-145
4.118	New Control Shelf Backplane (Release 23.0)	4-145
4.119	New Hardware (Release 23.1)	4-146
4.120	New Hardware (Release 26.05)	4-146
4.121	Non-ANSI Point Code Support (Release 20.0)	4-147
4.122	Non-Generation of Duplicate SEAS Autonomous Messages (Release 22.0)	4-147
4.123	Non-SCCP/ISUP Routing (IP7 Releases 1.0, 2.0)	4-147
4.124	Notification of Congestion Level Increase (Release 22.0)	4-147
4.125	Notification of Inability to Perform a Global Title Translation (Release 22.0)	4-148
4.126	Notification of Link Set Outage (Release 22.0)	4-148
4.127	Notification of Link Set Recovery (Release 22.0)	4-149
4.128	Notification of Locally Initiated Database Copy (Release 22.0)	4-149
4.129	Notification of MTP-Level Routing Error (Release 22.0)	4-149
4.130	Notification of Recovery from Link Congestion (Release 22.0)	4-150
4.131	NPP Conditioning Action Support for Extracting Variable Length Area Code from CgPN (Release 44.0)	4-150
4.132	NPP Enhancements: More NPP Formatting Actions for the INP Routing service part of IDP Relay (Release 45.0)	4-151
4.133	NPP Single Digit Wild Card Optionality (Release 44.0)	4-151

4.133.1	Feature Control Requirements	4-152
4.134	Number Pooling (Release 24.0)	4-152
4.135	Number Pooling/Efficient Data Representation (EDR) (Release 26.1)	4-153
4.136	OAP Upgrade Enhancement (Release 27.2)	4-156
4.137	OCTRETRN in 30-Minute Measurements Reports (Release 31.4)	4-156
4.138	Online Cartridge Formatting (Release 20.0)	4-156
4.139	OpCode Options Added to the ECAP Configuration Menu (ECAP 40.1)	4-156
4.140	Option for Subsystem Prohibit (Release 29.0)	4-157
4.141	Option for Turning on Class 1 Sequencing (Release 31.6.3)	4-159
4.142	Option to suppress NumberPortabilityStatusIndicator in SRI_ACK (Release 42.0)	4-160
4.142.1	Feature Control Requirements	4-160
4.143	Optional SCCP conversion for ITUi to ITUn and for ITUn to ITUi (Release 45.0)	4-160
4.143.1	Feature Control Requirements	4-160
4.144	Origin-based MTP Routing (Release 35.0)	4-160
4.145	Origin-based SCCP Routing (Release 35.0)	4-163
4.146	Output Measurements File Size Reduction (ECAP 41.1)	4-165
4.146.1	Measurement File Reduction Options Added to the ECAP Configuration Menu	4-165
4.146.2	Variable Measurements Collection Period	4-166
4.146.3	Variable File Transfer Offset Time	4-166
4.146.4	Multiple Output File Formats	4-166
4.146.5	Compression of Output Measurement Files	4-166

5 Features P - Z

5.1	Password Aging (Release 21.0)	5-1
5.2	Password Encryption (Release 21.0)	5-1
5.3	Password Requirements (Release 21.0)	5-2
5.4	PCS 1900 LNP Query (Release 26.0)	5-2
5.5	PDBA Proxy (EPAP 7.0)	5-6
5.6	Performance Enhancements (IP7 Release 3.0)	5-6
5.7	Per-Linkset Random SLS (Release 36.0)	5-7
5.8	Persistent Device States (Release 29.0)	5-8
5.9	Point Code and CIC Translation (Release 43.0)	5-9
5.9.1	Feature Control Requirements	5-9
5.9.2	Hardware Requirements	5-10
5.9.3	Limitations	5-10
5.10	Point-to-Point Connectivity for ITU Point Codes (IP7 Release 2.2)	5-10
5.11	Portability Check for Mobile Originated SMS (Release 29.1)	5-15
5.12	Pre-LNP Query Service GTT processing (Release 43.0)	5-17
5.12.1	Feature Control Requirements	5-18
5.12.2	Hardware Requirements	5-18

5.13	Prepaid IDP Query Relay Enhanced	5-18
5.14	Prepaid IDP Query Relay (IDP Relay) Service Portability (Release 41.1)	5-18
5.15	Prepaid Initial Detection Point Query Relay (Release 34.1)	5-19
5.16	Prepaid SMS Intercept - Phase 1 (Release 28.1)	5-21
5.17	Prevention of Congestion from Rerouted Traffic (Release 21.0)	5-22
5.18	Prevention of Link Oscillation (Release 21.0)	5-23
5.19	Preventive Cyclic Retransmission (PCR) (Release 20.0)	5-23
5.20	Priority Processing of Network Management Messages (Release 21.0)	5-30
5.21	Private Point Code (Releases 31.12, 34.0)	5-30
5.22	Prohibit Removing the Last Route to a Destination if that Destination is being Referenced by Mated Applications or Concerned Signaling Point Code Groups (Release 22.0)	5-32
5.23	Prohibit the Assigning of a Linkset with Linkset Types A or E to a Cluster Route (Release 22.0)	5-32
5.24	Provide 2 HSL and 64 LSL on SLIC (Release 46.5)	5-33
5.24.1	Hardware	5-33
5.25	Provisioning Database Interface (PDBI) Command Statistics (EPAP 13.0)	5-33
5.26	Provisioning Range for Gateway Screening (Release 22.0)	5-35
5.27	Proxy Point Code (Release 37.5)	5-37
5.27.1	Feature Control	5-38
5.27.2	Hardware Requirements	5-39
5.27.3	Limitations	5-39
5.28	Quality of Service Enhancements (IP7 Release 3.0)	5-39
5.29	Random SLS Generation (Release 28.0)	5-42
5.30	Remote Backup (Release 39.2)	5-42
5.30.1	Feature Control Requirements	5-43
5.30.2	Hardware Requirements	5-43
5.30.3	Limitations	5-43
5.31	Remote Upgrade Download (Release 39.2)	5-43
5.31.1	Feature Control Requirements	5-43
5.31.2	Hardware Requirements	5-43
5.31.3	Limitations	5-43
5.32	REPT-STAT-CLK Enhancements for Clocking (Release 28.2)	5-43
5.33	REPT-STAT-TRBL Enhancement (Release 29.0)	5-44
5.34	Response to Commands Issued Prior to Login (Release 21.0)	5-44
5.35	Revoking a User ID (Release 21.0)	5-44
5.36	Route SRI_SM for non-local or ported out subscribers using GTT (Release 42.0)	5-45
5.36.1	Feature Control Requirements	5-45
5.37	Routing Key Enhancements (IP7 Release 3.0)	5-45
5.38	RTDB Download Enhancement (Release 46.0)	5-46
5.39	RTDB Reload from Remote Time Interval (EPAP 16.0)	5-46
5.40	RTDB Retrieve (EPAP 9.0)	5-46

5.41	RTRV-RTE/RTRV-DSTN: Support of PC Wildcards (Release 35.0)	5-47
5.42	RTRV-STP Command (Release 35.0)	5-48
5.43	RTRV-STP on FTRA	5-48
5.44	RTRV-TBL-CAPACITY Enhancement (Release 29.0)	5-49
5.45	EAGLE 5 SCCP Capacity Increase (Release 41.1)	5-49
5.45.1	Feature Control Requirements	5-50
5.45.2	Hardware Requirements	5-50
5.46	SCCP Loop Detection (Releases 35.6, 37.5)	5-50
5.46.1	Feature Control Requirements	5-50
5.46.2	Hardware Requirements	5-51
5.46.3	Limitations	5-51
5.47	SCCP Message Type Screening (Release 22.0)	5-51
5.48	SCCP on SLIC TPS Increase [13.6k] (Release 46.6)	5-51
5.48.1	Hardware	5-51
5.49	SCCP Service Re-Route Capability (Release 34.3)	5-51
5.50	SCCP/TCAP Over IP Gateway for Point-to-Multipoint Connectivity (IP7 Release 1.0)	5-54
5.51	SCCS Interface Support (Release 21.0)	5-55
5.52	SCTP Checksum for Support for ADLER-32 and CRC-32 on per-card basis (Release 37.11)	5-55
5.52.1	Feature Control Requirements	5-55
5.53	SCTP Checksum Update (EAGLE Release 30.0/IP7 Secure Gateway Release 8.0)	5-56
5.54	SCTP Payload Protocol Identifier needs to handle Big Endian or Little Endian byte order (Release 42.0)	5-57
5.55	SCTP Retransmission Control (Release 28.1) (IP7 Release 6.0)	5-60
5.56	SEAS Enhancements (Release 26.0)	5-60
5.57	SEAS Enhancements, Autonomous Messages (Release 22.0)	5-65
5.58	SEAS Gateway Audit Command (CHK-UNREF-ENT) (Release 22.0)	5-66
5.59	SEAS Interface Support (Release 21.0)	5-66
5.60	SEAS Over IP (Release 37.5)	5-68
5.60.1	Feature Control Requirements	5-69
5.60.2	Hardware Requirements	5-70
5.60.3	Limitations	5-70
5.61	SEAS Verify Signaling Route-Set Status and SCCP Application Status Command (VFY-SRSAPST) (Release 22.0)	5-70
5.62	Secure GUI Access (EPAP 16.0)	5-70
5.63	Security Enhancements (EPAP 14.0)	5-71
5.64	Security Log Increase (Release 26.05)	5-72
5.65	Selective Alarm Inhibiting (Release 22.0)	5-73
5.66	Self Healing DN Range in EPAP Database (EPAP 14.0)	5-75
5.67	Selective Homing of EPAP RTDBs (Release 29.0)	5-76
5.68	SFAPP Use Case 3 — VLR Validation using IMEI (Release 46.7)	5-77
5.69	SFAPP Use Case 4 - Intelligent VLR Whitelist (Release 46.7)	5-79

5.70	Sigtran IPSP application on SLIC card (Release 46.3)	5-80
5.71	SIGTRAN Measurements Phase 1 (Release 38.0)	5-80
5.71.1	Feature Control Requirements	5-81
5.71.2	Hardware Requirements	5-81
5.71.3	Limitations	5-81
5.72	Simplifying BIP (Board ID PROM) for EAGLE STP Boards (Release 23.1)	5-82
5.73	Single Slot Enhanced DCM (Release 28.1) (IP7 Release 6.0)	5-83
5.74	SIP Application - FAX and MODEM URI Support and Configurable Thresholds (Release 46.0)	5-84
5.75	SIP NP Feature SIPOPTS Enhancements	5-84
5.76	SIP NP on SLIC Network Redundancy Enhancement (Release 46.5)	5-84
5.76.1	Hardware	5-85
5.77	SIP Number Portability (Release 45.0)	5-85
5.77.1	Feature Control Requirements	5-86
5.77.2	Hardware	5-86
5.78	SIP Stack Improvements (Release 46.0)	5-86
5.79	SLAN on E5-ENET Assembly (Release 37.0)	5-86
5.80	SLS Bit Rotation on Incoming Linkset (Release 40.0)	5-87
5.80.1	Feature Control Requirements	5-88
5.81	SMSREQ Handling for Migrated or Ported Subscribers (Release 41.1)	5-88
5.82	SMS-MO Blocking SCCP Spoofing (Release 46.3)	5-88
5.83	SNMP Interface on EPAP (EPAP 16.0)	5-88
5.84	SNMPv3 support for interface towards OCEEMS (Release 16.2)	5-89
5.85	Spare Point Code (Release 31.12)	5-89
5.86	Split Allowed CGPA Table (Release 22.0)	5-91
5.87	Split of Allowed SIO Table (Release 22.0)	5-91
5.88	S-Port Subscriber Differentiation (Release 42.0)	5-92
5.88.1	Feature Control Requirements	5-92
5.89	SS7 Firewall Enhancements (Release 46.6)	5-93
5.90	SS7 Firewall on EAGLE (Release 46.3)	5-93
5.90.1	Hardware	5-93
5.91	SS7 Firewall - Stateful Applications (Release 46.6)	5-93
5.91.1	Hardware	5-95
5.92	SS7 Firewall (Stateless Screening Enhancements) (Release 46.6)	5-95
5.93	SS7 Message Rejection Due to Screening (Release 22.0)	5-95
5.94	SS7 over High-Speed Signaling Link (Release 23.0)	5-96
5.95	SS7-Over-IP Gateway for Point-to-Point Links (IP7 Release 1.0)	5-97
5.96	SS7 SCCP-User Adaptation Layer (SUA) Request for Comment (RFC) (Release 31.10)	5-98
5.97	Standalone PDB on EPAP (EPAP 16.0)	5-98
5.98	STC on E5-ENET Assembly (Release 37.0)	5-99
5.99	STP LAN Feature (Release 20.0)	5-100

5.100	STPLAN Port to DCM (Release 26.0)	5-101
5.101	STPLAN SSED CM Capacity Increase (Release 34.0)	5-102
5.102	STPLAN with Default Router (Release 23.0)	5-102
5.103	SUA DAUD with SSN Support (Release 37.0)	5-104
5.104	Support >25 SCCP cards with EPAP T1200 application server (Release 42.0)	5-105
5.104.1	Hardware Requirements	5-106
5.105	Support 12 Million Ported Numbers (Releases 24.0, 25.0)	5-107
5.106	Support 22 Non-Provisionable EPAP Nodes (EPAP 13.0)	5-107
5.107	Support Changing the Linkset Name (Release 28.0)	5-107
5.108	Support CHG-GTT to change the GTA (Release 35.0)	5-108
5.109	Support CRP check for SRI_SM using TCAP digits (Release 43.0)	5-108
5.109.1	Feature Control Requirements	5-108
5.110	Support FastCopy on IPGW (Release 42.0)	5-109
5.110.1	Hardware Requirements	5-109
5.111	Support for 16 GTT Lengths in VGTT (Release 41.0)	5-109
5.111.1	Feature Control Requirements	5-109
5.111.2	Hardware Requirements	5-109
5.112	Support for 32 Prepaid SMS Intercept Platforms (Release 37.0)	5-109
5.113	Support for 32 Prepaid SMS Intercepts (EPAP 9.0)	5-110
5.114	Support for 2000 ITU Links per Node (Release 35.1)	5-111
5.115	Support for 2800 Provisioned Links Per Node (Release 41.1)	5-112
5.115.1	Feature Control Requirements	5-112
5.115.2	Hardware Requirements	5-112
5.115.3	Limitations	5-113
5.116	Support for IP7 8.0 Gateway Features (EAGLE Release 30.0/IP7 Secure Gateway Release 8.0)	5-113
5.117	Support for IPSG M3UA and SCTP Graceful Shutdown (Release 41.0)	5-113
5.117.1	Hardware Requirements	5-113
5.118	Support for LSMS Audit Enhancements (Release 26.1)	5-114
5.119	Support for LSMS Split Provisioning (Release 26.1)	5-118
5.120	Support for Matching Self-ID Rule in SEAS CHG-SID (Release 22.0)	5-119
5.121	Support for MTP Status Functions (IP7 Release 2.0)	5-119
5.122	Support for Provisioning Multiple EPAPs (Release 29.0)	5-120
5.123	Support for SCCP XUDT/XUDTS Messages, In-Sequence Delivery of Class 1 SCCP UDT/XUDT Messages (Release 31.6)	5-120
5.124	Support for Secure Gateway Functionality through IP7 7.0 (Release 29.0)	5-122
5.125	Support for TALI Architecture (IP7 Release 4.0)	5-122
5.126	Support for the CLLI Parameter for Adding or Changing Linksets (Release 22.0)	5-122
5.127	Support for the New Linkset Name Parameter for Changing the Attributes of a Route (Release 22.0)	5-123
5.128	Support for Up to 41 IPLIMx DCMs (IP7 Release 2.2)	5-124
5.129	Support G-Flex at 1700 TPS per DSM (ANSI only) (Release 31.6)	5-124

5.130	Support IPSPG Link Capacity Sharing (Release 42.0)	5-124
5.131	Support Java 1.5 on ELAP (ELAP 7.0)	5-125
5.132	Support Java 1.5 on EPAP (EPAP 9.0)	5-125
5.133	Support LSMS Disaster Recovery (Release 23.1)	5-125
5.134	Support Migration of EPAPs from T1000 to T1200 (EPAP 13.0)	5-126
5.135	Support of 4 IP Addresses for IPSPG Signaling Ports on SLIC card	5-127
5.136	Support of 750K System (SIGTRAN + ATM) TPS (Release 42.0)	5-127
5.136.1	Feature Control Requirements	5-128
5.136.2	Hardware Requirements	5-128
5.137	Support of E1 Master Clock Interface for SS7 Signaling Links (Optional) (Release 22.2)	5-128
5.138	Support of E1 Interface for SS7 Signaling Links (Optional) (Releases 22.2, 24.0)	5-128
5.139	Support of IPv6 on EAGLE Query Server (Release 1.0)	5-129
5.140	Support SCCP on SLIC (Release 46.4)	5-129
5.141	Supported Java Client (EPAP 16.0)	5-129
5.142	Suppression of Gateway Measurements on Non-Gateway Linksets (Release 25.0)	5-129
5.143	Synchronous E1 High Speed Link (SE-HSL) (Release 34.0)	5-129
5.144	Synchronous T1 High Speed Link (Release 41.0)	5-131
5.144.1	Feature Control Requirements	5-131
5.144.2	Hardware Requirements	5-132
5.145	TALI "A" Link Connectivity (Release 28.0)	5-132
5.146	TALON Development Kit (IP7 Release 2.0)	5-132
5.147	TCAP Opcode Based Routing (Release 41.0)	5-133
5.147.1	Feature Control Requirements	5-133
5.147.2	Hardware Requirements	5-134
5.148	TCAP Segmented SMS Support Phase 1 (Release 39.0)	5-134
5.148.1	Feature Control Requirements	5-134
5.148.2	Hardware Requirements	5-135
5.148.3	Limitations	5-135
5.149	TDM Global Timing Interface (Release 31.6)	5-135
5.150	Temporary Alarm Inhibiting and Offline Functions (Release 25.0)	5-135
5.151	Thresholding of UIM Messages (Release 25.0)	5-142
5.152	TIF Calling Party Number Conditioning (Release 44.0)	5-145
5.152.1	Hardware Requirements	5-146
5.153	TIF NP Service Portability (Release 41.1)	5-146
5.154	TIF Number Portability (Release 39.2)	5-146
5.154.1	Feature Control Requirements	5-147
5.154.2	Hardware Requirements	5-147
5.154.3	Limitations	5-147
5.155	TIF Number Substitution (Release 41.0)	5-147
5.155.1	Feature Control Requirements	5-148

5.156	TIF Range CGPN Blacklist (Release 44.0)	5-148
5.156.1	Feature Control Requirements	5-148
5.156.2	Hardware Requirements	5-149
5.157	TIF SCS Forwarding (Release 39.2)	5-149
5.157.1	Feature Control Requirements	5-149
5.157.2	Hardware Requirements	5-149
5.157.3	Limitations	5-149
5.158	TIF Selective Screening (Release 45.0)	5-149
5.158.1	Feature Control Requirements	5-150
5.159	TIF Simple Number Substitution (Release 39.2)	5-150
5.159.1	Feature Control Requirements	5-150
5.159.2	Hardware Requirements	5-150
5.160	TIF Subscriber CgPN Blacklist (Release 44.0)	5-150
5.160.1	Feature Control Requirements	5-151
5.160.2	Hardware Requirements	5-151
5.161	Time Stamps for rept-stat-trbl Report (Release 31.6)	5-151
5.162	Time-Based Inhibit Alarm (Release 35.0)	5-151
5.163	TINP (Release 38.0)	5-152
5.163.1	Feature Control Requirements	5-152
5.163.2	Hardware Requirements	5-152
5.163.3	Limitations	5-152
5.164	TOS Field Marked in Outgoing Packets (Release 46.0)	5-153
5.165	Transaction-based GTT Loadsharing (Release 36.0)	5-153
5.166	Translation Type Mapping (Release 21.0)	5-155
5.167	Triggerless ISUP Framework (Release 39.2)	5-156
5.167.1	Feature Control Requirements	5-156
5.167.2	Hardware Requirements	5-157
5.168	Triggerless LNP (Release 24.0)	5-157
5.169	TSM Warm Restart and Incremental Loading (Release 26.0)	5-157
5.170	TT Independence for LNP Queries (EAGLE Release 30.0/IP7 Secure Gateway Release 8.0)	5-167
5.171	TUP Message Type Screening (Release 31.6)	5-169
5.172	Two-Point IPLIMx (EAGLE 27.1, IP7 Release 2.2)	5-169
5.173	Unmate IP Security for Terminal and Measurements (Release 45.0)	5-170
5.174	Unregistered Routing Key Treatment (IP7 Release 3.0)	5-170
5.175	Update Validation (Release 34.0)	5-171
5.176	Upgrade Procedure Enhancements (Release 22.0)	5-171
5.177	Upgrading the Application Processor of the Main Assemblies from the Intel 286/386 to the Intel 486 Microprocessor (Release 20.0)	5-174
5.178	Use IMT Bus Instead of MBUS (Release 23.0)	5-175
5.179	User-Initiated Keyboard Locking (Release 22.0)	5-175

5.180	Using the DPC/SSN Parameters and GTA Range in Displaying Global Title Translations (Release 22.0)	5-178
5.181	Variable-Length Global Title Translation (Release 26.1) (IP7 Release 2.2)	5-178
5.182	Variable Length GTT (Release 26.1)	5-179
5.183	V-Flex Voice Mail Router (Release 37.6, 39.0, EPAP 9.5, 11.0)	5-181
5.183.1	Feature Control Requirements	5-182
5.183.2	Hardware Requirements	5-182
5.183.3	Limitations	5-182
5.184	Warning Message When LIMs Added with Insufficient TSMS (Release 25.0)	5-182
5.185	Weighted GTT Loadsharing (Release 36.0)	5-183
5.186	Weighted SCP Load Balancing (Release 27.2)	5-184
5.187	Wireless Number Portability (Release 23.1)	5-186
5.188	X.25/SS7 Gateway Feature (Release 20.0)	5-186
5.189	XUDT Conversion Enhancements (Release 43.0)	5-192
5.189.1	Feature Control Requirements	5-192
5.190	Year 2000 Compliance (Release 23.1)	5-192

6 EMS Features

6.1	Command Manager Interface Enhancements (EMS 40.0)	6-1
6.2	Command Manager Interface (EMS 43.0)	6-2
6.3	Command Manager Interface Enhancements - Command Scripts (EMS 41.0)	6-4
6.4	Command Manager Interface Enhancements - Controlling Access to Individual EAGLE 5 Systems (EMS 41.0)	6-6
6.5	Command Manager Interface Enhancements - User Activity Logging (EMS 41.0)	6-6
6.6	Enhanced SNMP Northbound Interface (EMS 41.0)	6-7
6.7	Enhanced SNMP Northbound Interface (EMS 42.0)	6-8
6.8	Fault/Communication Agent (EMS 43.0)	6-8
6.9	Historical Event Viewer (HEV) (EMS 43.0)	6-8
6.10	HTTPS Access for EAGLE EMS CMI (EMS 44.0)	6-9
6.11	Link Utilization Interface (EMS 42.0)	6-9
6.12	LUI Measurements Thresholding (EMS 44.0)	6-9

7 E5-MS/OCEEMS Features

7.1	Add Command History in EMS CMI for each user (Release 46.3)	7-1
7.2	Architecture (E5-MS 45.0)	7-1
7.3	Backup and Restore (E5-MS 45.0)	7-2
7.4	Command Management Interface (Configuration) (E5-MS 45.0)	7-3
7.5	Configurable CMI behavior against errors during script execution (Release 46.3)	7-4
7.6	Counter for command rejection at CMI (Release 46.3)	7-5
7.7	Decoupling of OCEEMS from EAGLE (Release 46.6)	7-5

7.8	E5-MS Support of EPAP Alarms via SNMP Feed (E5-MS 46.0)	7-6
7.9	E5-MS Support of LSMS Alarms via SNMP Feed (E5-MS 46.0)	7-6
7.10	EAGLE EMS Support and Compatibility with EAGLE 46.3 (OCEEMS 46.3)	7-6
7.10.1	Hardware	7-7
7.11	EAGLE EMS to support IPv6 for SBI for EPAP (Release 46.3)	7-7
7.12	Fault Management (E5-MS 45.0)	7-7
7.13	Inventory Management (E5-MS 45.0)	7-9
7.14	LDAP Client on OCEEMS (Release 46.6)	7-9
7.15	Link Utilization Interface (E5-MS 45.0)	7-10
7.16	Measurement Module (E5-MS 45.0)	7-11
7.17	Network Topology Discovery (EAGLE Discovery) (E5-MS 45.0)	7-12
7.18	North Bound Interfaces (E5-MS 45.0)	7-13
7.19	OCEEMS Support of SNMPv3 for North Bound Interfaces (OCEEMS 46.2)	7-14
7.20	OCEEMS to support SNMP v3 for EPAP (OCEEMS 46.5)	7-14
7.21	OCEEMS to support SNMP v3 for LSMS (OCEEMS 46.5)	7-15
7.22	Platform and Operating System Requirements (E5-MS 46.0)	7-15
7.23	Remove the need of root privileges to run/maintain/operate EEMS (Release 46.3)	7-15
7.24	Report Designer (E5-MS 45.0)	7-15
7.25	Reporting Studio (E5-MS 45.0)	7-16
7.26	Search engine in EMS CMI script execution results page (Release 46.3)	7-17
7.27	Security Administration (E5-MS 45.0)	7-17

My Oracle Support (MOS)

[My Oracle Support \(MOS\)](#) is your initial point of contact for any of the following requirements:

- **Product Support:**
The generic product related information and resolution of product related queries.
- **Critical Situations**
A critical situation is defined as a problem with the installed equipment that severely affects service, traffic, or maintenance capabilities, and requires immediate corrective action. Critical situations affect service and/or system operation resulting in one or several of these situations:
 - A total system failure that results in loss of all transaction processing capability
 - Significant reduction in system capacity or traffic handling capability
 - Loss of the system's ability to perform automatic system reconfiguration
 - Inability to restart a processor or the system
 - Corruption of system databases that requires service affecting corrective actions
 - Loss of access for maintenance or recovery operations
 - Loss of the system ability to provide any required critical or major trouble notification

Any other problem severely affecting service, capacity/traffic, billing, and maintenance capabilities may be defined as critical by prior discussion and agreement with Oracle.
- **Training Need**
Oracle University offers training for service providers and enterprises.

A representative at Customer Access Support (CAS) can assist you with [MOS](#) registration.

Call the CAS main number at 1-800-223-1711 (toll-free in the US), or call the Oracle Support hotline for your local country from the list at [Oracle Support Contacts](#). The emergency response provides immediate coverage, automatic escalation, and other features to ensure that the critical situation is resolved as rapidly as possible.

When calling, make the selections in the sequence shown below on the Support telephone menu:

1. Select 2 for New Service Request
2. Select 3 for Hardware, Networking and Solaris Operating System Support
3. Select one of the following options:
 - For Technical issues such as creating a new Service Request (SR), Select 1
 - For Non-technical issues such as registration or assistance with MOS, Select 2

You will be connected to a live agent who can assist you with MOS registration and opening a support ticket.

MOS is available 24 hours a day, 7 days a week, 365 days a year.

What's New in This Guide

This section introduces the documentation updates for Release 47.1 in Oracle Communications EAGLE Previously Released Features Reference.

Release 47.1 - F88482-01, October 2023

There are no updates in the document for this release.

1

Introduction

This chapter provides information about this manual, the documentation suite, Customer Care Center, and the features added with this release of the manual.

1.1 Overview

This manual provides summaries of previously released EAGLE or related features at the time of their release.

1.2 Scope and Audience

This manual is intended for any personnel interested in basic, historical information about features related to EAGLE, ECAP, ELAP, EPAP, EAGLE Element Management System, and IP7 Secure Gateway. Users of this manual must have a working knowledge of telecommunications and network installations.

1.3 Features Added in This Revision

These previously released EAGLE features are new in this revision of *Previously Released Features*:

- [EAGLE Database Increase to 480M DN + 600M Flexible IMSI/IMEI Allocation \(Release 46.7\)](#)
- [SFAPP Use Case 3 — VLR Validation using IMEI \(Release 46.7\)](#)
- [SFAPP Use Case 4 - Intelligent VLR Whitelist \(Release 46.7\)](#)

1.4 Documentation Admonishments

Admonishments are icons and text throughout this manual that alert the reader to assure personal safety, to minimize possible service interruptions, and to warn of the potential for equipment damage.

Table 1-1 Admonishments





Icon	Description
 DANGER	Danger: (This icon and text indicate the possibility of <i>personal injury</i> .)
 WARNING	Warning: (This icon and text indicate the possibility of <i>equipment damage</i> .)

Table 1-1 (Cont.) Admonishments

Icon	Description
 CAUTION	Caution: (This icon and text indicate the possibility of <i>service interruption</i> .)
 TOPPLE	Topple: (This icon and text indicate the possibility of <i>personal injury and equipment damage</i> .)

1.5 Manual Organization

This manual is organized into the following chapters:

- [Introduction](#) provides information about this manual, how to contact the Customer Care Center, and a list of previously released features in alphabetical order.
- [Features Num - E](#) describes features starting with numbers and letters from A to E.
- [Features F - K](#) describes features starting with letters from F to K.
- [Features L - O](#) describes features starting with letters from L to O.
- [Features P - Z](#) describes features starting with letters from P to Z.
- [EMS Features](#) describes features associated with EAGLE Element Management System (EMS).
- [E5-MS/OCEEMS Features](#) describes features associated with EAGLE Element Management System (E5-MS).

1.6 Related Publications

For information about additional publications related to this document, refer to the Oracle Help Center site. See [Locate Product Documentation on the Oracle Help Center Site](#) for more information on related product publications.

1.7 Locate Product Documentation on the Oracle Help Center Site

Oracle Communications customer documentation is available on the web at the Oracle Help Center (OHC) site, <http://docs.oracle.com>. You do not have to register to access these documents. Viewing these files requires Adobe Acrobat Reader, which can be downloaded at <http://www.adobe.com>.

1. Access the Oracle Help Center site at <http://docs.oracle.com>.
2. Click **Industries**.
3. Under the Oracle Communications subheading, click the **Oracle Communications documentation link**.

The Communications Documentation page appears. Most products covered by these documentation sets will appear under the headings "Network Session Delivery and Control Infrastructure" or "Platforms."

4. Click on your Product and then the Release Number.

A list of the entire documentation set for the selected product and release appears.

5. To download a file to your location, right-click the PDF link, select `Save target as` (or similar command based on your browser), and save to a local folder.

2

Features Num - E

This chapter describes features starting with numbers and letters from A to E.

2.1 1M System TPS (Release 45.0)

The 1M System TPS feature increases the allowed System TPS (SIGTRAN TPS + ATM TPS) to 1 million transactions per second (TPS). This feature adds capacity to users who already have HIPR2 High Rate Mode feature ON and are running with any of the suggested system configuration and traffic pattern.

The maximum allowed System TPS for all SIGTRAN and ATM links and linksets provisioned in the system includes IPGW, IPSG, IPLIM and ATM links and linksets. The maximum allowed System TPS value is 500,000, 750,000 or 1,000,000 depending on the status of the HIPR2 High Rate Mode, MFC, and 1M System TPS features:

- If the HIPR2 High Rate Mode feature is disabled or turned off, the maximum allowed System TPS is 500,000 (500k).
- If the HIPR2 High Rate Mode feature is turned on and the 1M System TPS feature is disabled or turned off, the maximum allowed System TPS is 750,000 (750k).
- If the HIPR2 High Rate Mode feature, the MFC feature, and the 1M System TPS feature are turned on, the maximum allowed System TPS is 1,000,000 (1M).

The System TPS calculation includes IPLIM TPS and ATM TPS usage. This calculation may cause existing configurations to exceed the maximum allowed System TPS value of 500k, 750k or 1M. The current configuration will continue to function; however, the user will be prevented from entering a provisioning command that increases their System TPS value.

The user can also provision more IPGW, IPLIM, IPSG and ATM cards to configure the higher System TPS. If user wants to add new IPGW or ATM links, add the first link to an IPLIM card, increase the iptps of an IPGW linkset or increase the slktps/rsvdslktps/maxslktps values of an IPGW linkset beyond 750,000, the 1M System TPS feature must be turned on. For provisioning the system TPS above 750,000 and up to 1,000,000, the 1M System TPS feature must be turned on.

If the EAGLE already has 1,000,000 System TPS provisioned, the user cannot enter a provisioning command that will increase the provisioned System TPS.

2.1.1 Feature Control Requirements

FAK for Part Number 893-0407-01

The feature can be turned on and off.

2.2 3 Links per E5-ATM Card (Release 43.0)

The 3 Links per E5-ATM Card feature allows the E5-ATM card to support a maximum of 3 ATM links. The third link is referred to as link A1 and can be assigned to the third port on an E5-ATM card. The E5-ATM card must be re-loaded before link A1 can be supported.

The 3 Links per E5-ATM Card feature is a quantity feature with part numbers ranging from 893-0391-01 to 893-0391-77. Each quantity FAK supports the feature in the increment of 5 E5-ATM cards.

2.2.1 Feature Control Requirements

- FAK for Part Number in the range 893-0391-01 to 893-0391-77. Each FAK enables the 3 Links per E5-ATM Card feature for an increment of 5 E5-ATM cards.
- Any ATM link provisioned on the system must have a VCI value less than or equal to 16383 before the feature can be enabled.
- A temporary FAK cannot be used to enable the feature.
- After a feature quantity is enabled, the default status of the feature is ON. A feature cannot be turned off after being turned on.
- After a feature quantity is enabled, a feature with a lower quantity cannot be enabled.

2.3 5 Minute Linkset Data (Release 25.0)

Release 25.0 adds two new schedules to the **EAGLE** reporting capabilities: D_NM and D_MTCS. Both schedules are available through the **EAGLE** terminal interface, and through the **SEAS** interface via the **OAP**.

The following figure provides a high-level diagram of the capabilities implemented by these new schedules. The D_MTCS schedule is a new capability for generating an on-demand maintenance status report using the `rept-meas` command (**EAGLE**) or the `send-dem-meas` command (**SEAS**). The report is generated from maintenance block data that is currently maintained within the **OAM**.

D_NM is a five-minute linkset schedule and supports the `lnkset` entity type. D_MTCS is a snapshot of the maintenance status indicators, and supports the `link` and `lnkset` entity types.

Figure 2-1 Concept Diagram

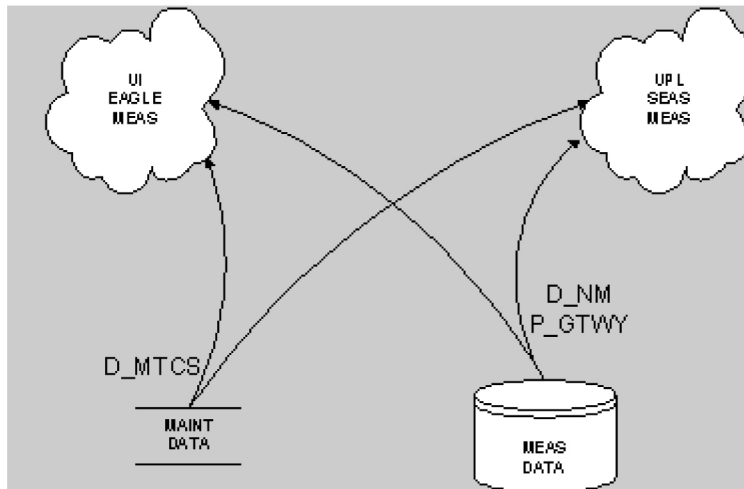

The **D_NM** schedule provides five-minute throughput measurements on a per-linkset basis, on demand. The schedule is available through the **EAGLE HMI** or the **SEAS** interface. Although the reporting of the **D_NM** schedule is new for Release 25.0, the mechanisms for collecting the data contained in the schedule are currently implemented in the **EAGLE** for link data collection. This feature reorganizes the link data collection to collect on a linkset basis. The linkset measurements are aggregated in a new data store over a five-minute period, and reported in the **D_NM** schedule. This feature does not impact per-link measurements data reporting.

The **D_MTCS** schedule provides the current maintenance state (active, out-of-service, or unavailable) of signaling links and linksets. The **D_MTCS** schedule is available on demand via the `rept-meas` command through the **EAGLE HMI**, or via the `send-dem-meas` command through the **SEAS** interface. Both interfaces support a parameter to specify reporting current data (`period=active`) for a link or linkset.

2.4 5-8 Bit Sequencing Assurance (Release 24.0)

Description

The signaling link selection field (**SLS**) in an **MSU** is used to balance traffic across the links in each linkset that a message passes through. The originator of the traffic can, by using the same **SLS** for a group of messages, guarantee that the same links are selected and guarantee that the traffic will be in sequence. In previous releases, the **EAGLE** evenly distributed traffic using a 5-bit **SLS** by using a 3-bit counter to fill in the three most significant bits in the **SLS**. This can result in missequencing of **MSUs**, as shown in the following example and figure:

1. Node 1-1-1 generates two messages with the same **SLS**, intending for them to be sequenced, and transmits them across link 1.
2. **STP 2-2-2** converts the 5-bit **SLS** to an 8-bit **SLS**, resulting in two different **SLS** codes. The two messages leave **STP 2-2-2** on links 2 and 3 and arrive out of order at node 3-3-3.

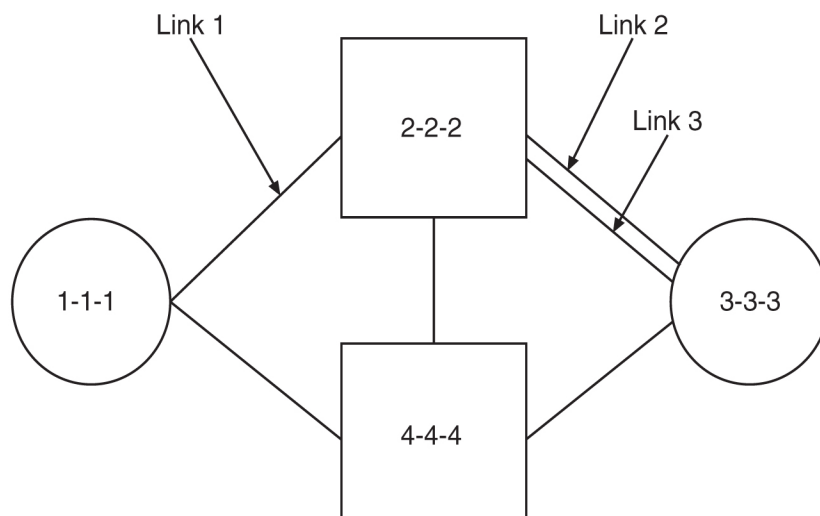
Figure 2-2 Example Network for Problem Description

This feature ensures that when a 5-bit **SLS** is converted to an 8-bit **SLS**, the **MSUs** arrive at the destination node in the order that they were generated by the originating node. The **EAGLE** also makes these **SLS** conversions:

- 5-bit **ANSI SLS** to 4-bit **ITU SLS**
- 4-bit **ITU SLS** to 5-bit **ANSI SLS**
- 8-bit **ANSI SLS** to 4-bit **ITU SLS**

The **EAGLE** does not convert a 4-bit **ITU SLS** to an 8-bit **ANSI SLS**.

The 5-bit to 8-bit **SLS** conversion takes place during the routing process, after the linkset is selected, but before the signaling link is selected. The **ITU** to **ANSI SLS** conversion takes place during the **ANSI** to **ITU MSU** conversion and after the outgoing signaling link is chosen.

Signaling Link Selection Conversion

5-bit to 8-bit **SLS** conversion is performed under these conditions:

- The incoming linkset is an **ANSI** linkset
- The `asl8=no` parameter is assigned to the incoming linkset
- The outgoing linkset is an **ANSI** linkset
- The outgoing linkset has either the `slscnv=on` and `slsci=yes` parameters, or the `slscnv=perls` and `slsci=yes` parameters assigned to it
- The three most significant bits of the **SLS** are zero.

When an **ITU SLS** is converted to an **ANSI SLS**, the **ITU SLS** is always converted to an **ANSI 5-bit SLS**. If the **MSU** containing the converted **SLS** is rerouted because of a link outage, the **SLS** may be converted from a 5-bit **SLS** to an 8-bit **SLS**.

When an **ANSI SLS** is converted to an **ITU SLS**, the **ANSI SLS** is always converted to an **ITU 4-bit SLS**.

When a 5-bit **ANSI SLS** is converted to an 8-bit **ANSI SLS**, the three most significant bits of the **SLS** are set using a function of originating point code and incoming port. This ensures that **MSUs** with the same originating point code, **SLS**, and incoming port

will always have the same **SLS** after the conversion, guaranteeing that the **MSUs** arrive at the destination in the same sequence that they were sent.

All **ANSI MSUs** originating from the **EAGLE** will have an 8-bit **SLS**.

2.5 6-Way Loadsharing on Routesets (Release 41.0)

The 6-Way Loadsharing on Routesets feature allows loadsharing across all 6 routes to a destination or exception route.

2.5.1 Feature Control Requirements

Feature control requirements for the 6-Way Loadsharing on Routesets feature include:

- A FAK for part number 893-0198-01
- A temporary FAK cannot be used to enable the feature.
- The feature cannot be turned off after it has been turned on.

2.5.2 Limitations

The 6-Way Loadsharing on Routesets feature does not support IPGWx destinations.

2.6 8-Bit SLS Support (Release 21.0)

The signaling link selection (**SLS**) is a field in the routing label of the **MSU**. It is set by the originator of the **MSU** to a random value. It is used by **EAGLE** to pick which outgoing linkset and signaling link to use. **MSUs** with the same destination and the same **SLS** take the same path through the network, the same linksets and the same links. The **MSUs** are guaranteed to arrive at the destination in sequence.

The value of the **SLS** is used by the **EAGLE** to distribute traffic over the available signaling links in a linkset. The **EAGLE** uses only 16 **SLS** codes for assignment to linksets or combined linksets. For linksets containing 9 to 15 signaling links, some signaling links are assigned two **SLS** codes while other signaling links are assigned a single **SLS** code. This can create an imbalance in traffic distribution and inefficient link utilization. To overcome this problem, the **EAGLE** uses an 8 bit **SLS** code which provides the **EAGLE** with 256 **SLS** codes. More **SLS** codes means the traffic can be distributed more evenly.

Because some signaling points will still be generating messages with a 5 bit **SLS**, the **EAGLE** provides an option to convert 5 bit **SLSs** in messages to 8 bit **SLSs**. This option is set on an outgoing linkset basis. **ITU** messages continue to use 4 bit **SLSs**. Messages that go from **ITU** to **ANSI** are currently converted from a 4 bit **SLS** to a 5 bit **SLS**. If the outgoing linkset uses 5 to 8 bit conversion, the **ITU** messages are converted to 8 bit **SLSs**. If the linkset does not use 5 to 8 bit conversion, the **ITU** messages are converted from 4 bit to 5 bit **SLS**.

MSUs generated by the **EAGLE** (**MTP** management, **SCCP** management, and messages received from X25) will have an 8 bit **SLS**.

The `slsci` parameter, used with either the `ent-ls` or `chg-ls` commands, indicates whether the 5 bit to 8 bit **SLS** conversion feature is used to select signaling links for outgoing messages directed to the specified linkset. If the `slsci=yes` parameter is specified, the **EAGLE** replaces any 5 bit **SLS** value contained in received messages with a random 8 bit value before they are used by the **EAGLE** to select the outgoing signaling link in that linkset.

The `slsci=yes` parameter can only be specified for linksets with **ANSI SS7** adjacent point codes.

2.7 15 Minute Measurements (Release 31.3)

The 15 minute Measurements feature is controlled by a feature access key and a measurement option. Turning on the feature requires a part number. The feature cannot be turned off once turned on. It is a Permanently **ON** feature. Upon turn on, the collection period defaults to the 30-minute option to maintain compatibility with the existing system capabilities.

The feature becomes operational when the collection period has been changed to 15 minutes. The collection period can be changed from 30 minutes to 15 minutes (and vice versa) by changing the 15 Minute Measurements collection option of the Measurements Platform options table. When the 15 Minute Measurements collection is disabled, measurements data will be collected and reported each half-hour at hh:00 and hh:30. When the 15 Minute Measurements collection option is selected to enabled, measurements data will be collected and reported four times each hour at hh:00, hh:15, hh:30, and hh:45. The current state of the option is displayed with the Measurements Platform options. Report types supported by 15 Minute measurements are: `systot`, `comp`, `gtwy`, and `avl`.

Turning on the feature requires a feature access key. This feature cannot be turned off once turned on, therefore it is a Permanently **ON** feature. When the feature is turned on, the collection period defaults to the 30-minute option to maintain compatibility with the existing system capabilities.

2.8 18 GB to 36 GB Hard Drive Upgrade (Release 29.1) (IP7 Release 7.1)

Description

EAGLE Release 29.1 requires that the **EPAP** databases accommodate 56 million G-Flex entries. Additional disk space is being provided by way of a hardware disk replacement, from 18 **GB** disks to 36 **GB** disks. All the new space on the data disk (18 **GB** minus overhead) will be appended to the database file system `/usr/db`. The additional space on the system disk (18 **GB** minus overhead) will be appended to the swap space. The disk upgrade will occur during a maintenance window, when no software upgrade is scheduled.

Although this feature has been developed specifically for the **EPAP**, it is not application-specific. This hard drive upgrade could be performed on any **MPS** server running any **GA** release.

Upgrade Procedure

The upgrade will be performed as follows:

- The technician will label the disks in the system and the disks in the upgrade kit.
- Using DiskSuite functionality, half of the old disks will be replaced with the new disks, and will sync with the remaining old disks.
- Once the disks have been sync'd, the remaining old disks will be replaced with the remaining new disks. The new disks will then sync again.

- A script will expand the `/usr/db` and swap file systems to use all the space available.

A backout will be performed as follows:

- The **MPS** will be brought to run-level zero.
- The technician will remove the 36 **GB** disks, install all the old disks, and remove the new disks.
- The technician will boot the **MPS**.
- A script will re-mirror and repair the metadbs.

Hardware Requirements

This feature requires that all four 18 **GB** disks on an individual **MPS** be replaced with 36 **GB** disks. (New **MPS**'s with the **EPAP** application will be manufactured with the 36 **GB** disks.)

2.9 24-Bit ITU-N Point Code Support Feature (Release 31.0)

The 24-bit ITU-N point code routing label structure consists of the **Destination Point Code (DPC)**, **Originating Point Code (OPC)**, and the **Signaling Link Selection** fields.

Both the **DPC** and **OPC** are 24 bits in length, and **SLS** is the code for signaling link selection for load sharing. Currently, only the least 4 bits of the **SLS** are used. The upper 4 bits are used as part of **CIC** in the telephone message label. For other messages, the upper 4 bits of the **SLS** are set to 0000.

Figure 2-3 24-bit ITU-N Point Code Routing Label

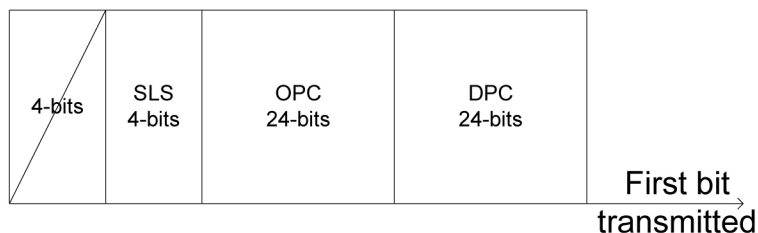

2.10 48 Million Numbers (Release 27.0)

Overview

The 48 Million Number feature for **EAGLE** Release 27.0 provides the capability to expand the number of ported numbers supported on one **EAGLE** platform from 12 to 48 million numbers. This feature represents both an increase in the number of ported records a single **EAGLE** node can support and a re-architecture of the current **LNP** solution (i.e. the **LSMS-OAP-OAM LNP** interface) for increased database update performance.

The terms **MPS** and **ELAP** are used to describe the hardware and software that is replacing the **EOAP** and the **LNP** functions of the **OAM**. **MPS** refers to the hardware and **OS** software of the new platform. **ELAP** refers to the 48 million number application running on the **MPS**.

This feature is optional and requires a corresponding **LSMS** feature.

General Description

Customer databases of **Local Number Portability (LNP)** data are constantly growing. **EAGLE** Release 27.0 and **LSMS** Release 4.0 introduce the 48 Million Number feature to satisfy customer database size requirements. Because of the magnitude of the database size increase, several areas of the existing **EAGLE/LNP** architecture have been upgraded. The following functionality has been changed and improved for Release 27.0:

- Ownership of the "master" or "golden" real-time **LNP** database has moved from the **EAGLE OAM** to the **ELAP**.

The data model for the new **LNP** solution closely resembles that of the International **LNP** solution. Data is collected at the **LSMS** from the **NPAC** (for subscription data) and from local provisioning on the **LSMS** (for default **NPANXX**, split **NPANXX** and other types of **LNP** records). This data is sent to the active **ELAP** at an **EAGLE** running Release 27.0 across a **TCP/IP** connection in the customer's network. The **ELAP** stores the data locally, and replicates it to the mate **ELAP**. The **ELAP** provides real-time database loading and provisioning functions for the **EAGLE DSM** cards, using two dedicated Ethernet networks between the **MPS** System and the **EAGLE DSM** cards.

When the 48 Million Number feature is enabled, this new data model supersedes the existing **EAGLE LNP** model. The **EAGLE OAM** will not store **LNP** databases in Release 27.0. Also eliminated with the 48 Million Number feature are the **BLM** and **DCM** cards that previously were required to support **EBD&A**.

- The transmission rate of database updates from the **LSMS** to the **EAGLE** has increased from 2 **TN/sec** to 25 **TN/sec**.

Prior to Release 27.0, **LNP** updates were sent from the **LSMS** to the **OAP** over the customer's network. The minimum **OAP** hardware in the field today runs on an 85MHz Sparc-4 platform. The **OAP** translates the data from the **LSMS** to character based commands resembling **SEAS UPL** commands for **LNP**. These commands are sent across a dedicated serial link to an **EAGLE** terminal port at 19,200 Kpbs. The command is then parsed and validated by the **EAGLE** before the real-time database is updated. Real-time updates are sent to **SCCP** cards serially using a card list.

With Release 27.0, the 48 Million Number feature provides a much faster path for updates. **LNP** updates are sent from the **LSMS** to the **ELAP** over the customer's network. The **ELAP** performs minimal parsing and validation before updating the real-time database. Real-time updates are sent to the **EAGLE DSMs** in parallel using multicast technology.

- Enhanced Bulk Download and Audit (**EBD&A**) is supported directly by the **ELAP**. The **ELAP** now provides all of the functionality of **EBD&A**.
- All cartridge-based bulk download operations have been eliminated.

Bulk loading is accomplished using the **EBD&A** functionality provided by the **ELAP**. Since **EAGLE** will not store the real-time database on disk, a cartridge based bulk load is no longer necessary.

- Real-time databases are recovered from one of the mate **EAGLE's ELAPs** in a disaster situation (**ELAP** failure at one **EAGLE**).

In the unlikely event of a catastrophic failure of the complete **MPS** system at one **EAGLE**, resulting in the loss of the real-time database, it will be possible to copy

the data from one of the **MPS** servers of the mated **EAGLE** node. After the **MPS** fault has been corrected, a craftsperson may gain access to it via a modem or through the customer's network. It will then be possible to initiate a connection to one of the **MPS** servers at the mate **EAGLE** site and initiate a transfer of the real-time database.

- The **EAGLE** security log functionality has been moved to the **ELAP**.

The following figure shows the system architecture supporting the 48 Million Number feature.

Figure 2-4 System Architecture Supporting 48 Million Number

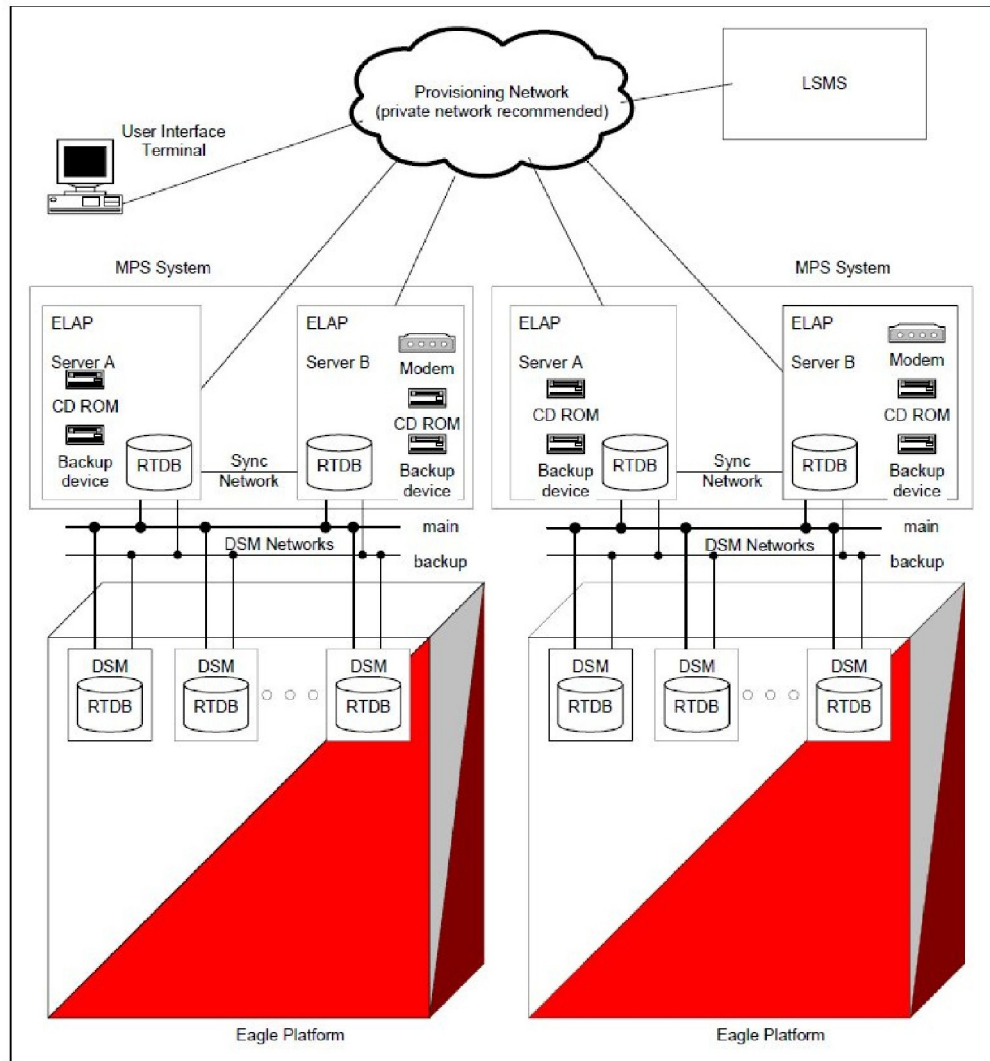

Attached to each **EAGLE** is an **MPS** System, consisting of two **MPS** Servers (Server A and B) and their associated platform software (e.g., Operating System, **DBMS**, etc.). The servers in the **MPS** System execute the software developed for the 48 Million Number feature, which is referred to as the "**ELAP** software."

Throughout the remainder of this description, when the term "**ELAP**" is used, it means "the **ELAP** software running on an **MPS** Server." Thus when we say that there are two **ELAPs** attached to each **EAGLE**, we mean that there are two **MPS** Servers attached to each

EAGLE, both of which are running the **ELAP** software. These two **ELAPs** run in a mated-pair configuration, with one behaving as the "active **ELAP**" and the other as the "standby **ELAP**."

System-Level Requirements

When the 48 million number feature bit is on, the following attributes of the **EAGLE** change:

- **OAM**-based **LNP** commands are not be allowed (`tt-serv` is allowed).
- **MPS**-based **LNP** commands are allowed (`rtrv-` commands only).
- Enhanced Bulk Download (**EBDA**) functionality is implicitly inherited by the new architecture

The 48 million number architecture inherits all functionality of the 12 million number architecture (except for a separate bulkdownload component). This includes:

- Support **DN** to **LRN** mapping and up to six services for message relay. **CLASS**, **LIDB**, **ISVM** and **CNAM** message relay service are supported. (Customer-defined services are supported.)
- Support **AIN/IN**, **IS-41** and **PCS 1900 LNP** query/response.
- Support Measurements (**OAM** can retain **LNP** Measurements).
- Support Transaction Log for **LNP** updates.
- Support for **MPS** alarming via **EAGLE** terminal.
- Support warm restart/incremental loading of the **DSM** card.
- Support loading the **DSM** card.
- Support Warm/Cold Restart of the **DSM** card
- **Database** storage of the **LNP** data from the **LSMS**.

 **Note:**

The **MPS** architecture supports a real-time database only

- **LNP** Commands (`tt-serv` and `rtrv-` only)

There is one security log on the **ELAP**. The security log on the **ELAP** logs global (across all **DSM** cards) **LNP** updates as one entry, regardless of the number of **DSM**'s provisioned. However, actions taken for a specific **DSM** card by the **ELAP** are logged on a per-**DSM** card basis.

The 48 million number architecture does not preclude the operation of the mate **STP** with the 12 million number architecture.

Required Hardware

To support 48 Million Numbers feature and the increased download rate from the **NPAC/LSMS**, the following new hardware is being introduced:

DSM

The **Database Services Module (DSM)** supports 48 million numbers by providing 1 GB daughterboard memory increments up to a total of 4GB. The **DSM** also provides **TCPI/IP** connectivity directly to the **MPS**.

Table 2-1 Supported DSM Configurations

Name	Description	Maximum number of ported numbers supported
DSM1GB	DSM with 1GB populated memory	12,000,000
DSM2GB	DSM with 2GB populated memory	24,000,000
DSM3GB	DSM with 3GB populated memory	36,000,000
DSM4GB	DSM with 4GB populated memory	48,000,000

The **DSM** does not support the `alloc-mem` command to allocate daughterboard memory. Instead, the memory physically present on the board determines the number of ported records supported.

MPS

The **Multi-Purpose Server (MPS)** running the **ELAP** application is designed as a replacement not only for the **LNP** functionality contained in the **EOAP**, but also for the **LNP** database that currently resides on the **OAM**. The **MPS** fits into one general purpose frame (**GPF**).

Upgrade Considerations

ELAP

ELAP software is new software. All initial applications of this feature will be new installations. Future software upgrades will be addressed with the Solaris "pkgadd" utility. The following data must be preserved or re-generated for upgrade:

- Data configured through the user interface
- Security logs
- Data provisioned from the **LSMS**

Each of these must be addressed by any future upgrade.

Maintenance

Three upgrade considerations affect maintenance:

- Support the **EPAP** alarms defined in Release 26.05 and 26.1 during upgrade. This must be done for both **UAMs** and the `rept-stat-mps` output.
- Allow **TSM** cards to co-exist with **DSM** cards and support the output in all `rept-stat` reports.
- Allow for the conversion of **DSMs** from **DSM** operation to **TSM** operation via a database restore operation.

Measurements

Measurements data are not preserved from a prior release to the upgrade release during an upgrade. If the customer desires to retain a record of pre-upgrade measurements, a hardcopy of the measurements data can be obtained using the documented **LNP** measurement report procedures. Alternatively, measurements data can be copied to a

Measurements removable cartridge using the `copy-meas` command. The data is then available for offline (non-**EAGLE**) processing. Measurements data cannot be restored to the upgraded **EAGLE** due to potential changes in data formats as a result of the upgrade.

LNP Measurements are preserved when the `LNP48MIL` feature bit is enabled after upgrade.

2.11 56 Million G-Flex Entries (Release 29.1) (IP7 Release 7.1)

Description

The 56 Million **G-Flex** Entries feature is a product of the 18GB (P/N 804-1282-01) to 36GB disk (P/N 804-1548-01) hard drive upgrade; see “[18GB to 36GB Hard Drive Upgrade \(Release 29.1\) \(IP7 Release 7.1\)](#)”. As a result of this increased storage capacity, the existing **EPAP** and **EAGLE** software now can support 56 Million **G-Flex** entries.

Hardware Requirements

This feature requires the 36 **GB** disk hard drive (P/N 804-1548-01).

2.12 64 PC support in M3UA DAUD message (Release 42.0)

Transmitted M3UA network management messages in response to **M3UA** DAUDs are revised to be handled in separate phases before and after MSUs are transmitted during time slice processing. This separation allows support of up to 64 point codes.

For the first phase, no more than 20% of the total reserved SLKTPS (RSVDSLKTPS) assigned to the association on which the **DAUD** was received is used to transmit DAUD response messages. If one or more of the association's links is found with the RSVDSLKTPS set to zero, then the TPS sum is set to the maximum SLKTPS (MAXSLKTPS) for the first link found. No more than 20% of the MAXSLKTPS assigned to the association's first link found with no RSVDSLKTPS is used to transmit DAUD response messages. For additional discussion of RSVDSLKTPS and MAXSLKTPS, see [Support IPSPG Link Capacity Sharing \(Release 42.0\)](#).

For the second phase, after all the MSUs on the transmit queue have been sent, all associations can compete for the remaining card capacity if needed. The capacity is based on the MAXSLKTPS. The available remaining capacity is shared among the associations that perform DAUD processing. If more than one association needs grants, then grants are distributed in a round robin fashion.

For a DAUD message received with 64 affected point codes, in order for the audit responses to be guaranteed enough bandwidth, it is recommended to set the RSVDSLKTPS/MAXSLKTPS high enough to accommodate potentially up to 128 responses from this audit.

2.13 80 SE-HSLs on E5 Cards (Release 41.1)

The 80 SE-HSLs on E5 Cards feature allows the Synchronous E1 High Speed Link (SE-HSL) feature to support quantities of 72 or 80 high speed links on HC-MIM and E5-E1T1 cards.

2.13.1 Feature Control Requirements

- FAK for Part Number 893-0130-10—72 SE-HSL links
- FAK for Part Number 893-0130-11—80 SE-HSL links
- After a quantity is provisioned, a lower quantity cannot be provisioned.

2.13.2 Hardware Requirements

Synchronous E1 high-speed links can be added to HC-MIM or E5-E1T1 cards.

2.14 96M Database on E5-SM4G card (Release 38.0, EPAP 10.0)

The 96M Database on E5-SM4G card feature allows an EPAP user to use E5-SM4G cards to support the same database capacity that is currently supported for DSM cards, using combinations of DN, IMSI, and IMEI entries.

2.14.1 Feature Control Requirements

There are no feature control requirements identified for this feature.

2.14.2 Hardware Requirements

This feature requires E5-SM4G or 4G DSM cards with EPAP-based applications.

2.14.3 Limitations

When this feature is implemented, the capacity limits for combinations of DN/IMSI entries may not support 96M. The limits are as follows.

Table 2-2 DN/IMSI Capacity Limits

# DN (millions)	# IMSI (millions)
96	0
90	7.5
84	7.5
78	15
72	22.5
66	30
60	30
54	37.5

Table 2-2 (Cont.) DN/IMSI Capacity Limits

# DN (millions)	# IMSI (millions)
48	45
36	52.5
24	67.5
18	75
6	82.5
0	90

This decrease in capacity is based on high-level engineering design for the feature.

2.15 120 Million EPAP DN/IMSI Entries (Release 39.1)

The 120 Million EPAP DN/IMSI Entries feature allows up to 120 million entries to be provisioned in the RTDB database. The entries can consist of directory numbers (**DN**s), International Mobile Subscriber Identities (**IMSI**s) or a mixture of DN and IMSIs. Up to 100,000 DN range entries are supported.

2.15.1 Hardware Requirements

The 120 Million EPAP DN/IMSI Entries feature requires Service Module cards. Any DSM cards that are used must have 4G of memory.

250 GB hard disk drives are required in the EPAP provisioning servers.

2.15.2 Limitations

The 120 Million EPAP DN/IMSI Entries feature has the following limitations:

- Once customers have installed the 120 Million EPAP DN/IMSI Entries feature, all prior PDB backups are no longer valid. Restoration of a backup made prior to the upgrade to the 120 Million EPAP DN/IMSI Entries feature can result in an inability of the PDBA software and MySQL daemon to start up. Contact Tekelec Customer Service for assistance with these restorations.
- Once customers have upgraded from EPAP 10.0 or 11.0 to EPAP 12.0 and beyond, RTDB backups made prior to the upgrade are no longer compatible with the software. If the EPAP software detects that such an incompatible RTDB has been restored, the database will be marked DB DIFF and RTDB. A reload (or restore from a post-upgrade backup) must be performed.

When this feature is implemented, the capacity limits for combinations of DN/IMSI entries may not support 120M. The new limits for EPAP 12.0 are shown in [Table 2-3](#).

Table 2-3 DN/IMSI Capacity Limits

# DN (millions)	# IMSI(millions)
120,000,016	0
112,500,015	7,500,001
105,000,014	15,000,002

Table 2-3 (Cont.) DN/IMSI Capacity Limits

# DN (millions)	# IMSI(millions)
97,500,013	22,500,003
90,000,012	30,000,004
82,500,011	37,500,005
75,000,010	45,000,006
67,500,009	52,500,007
60,000,008	60,000,008
52,500,007	67,500,009
45,000,006	75,000,010
37,500,005	82,500,011
30,000,004	90,000,012
22,500,003	97,500,013
15,000,002	105,000,014
7,500,001	112,500,015
0	120,000,016

2.16 120 Million LNP Numbers (Release 32.0)

Description

The 120 Million **LNP** number feature provides the capability to expand the maximum number of ported/pooled **LNP** numbers supported on one **EAGLE** platform from 96 million to up to 120 million **LNP** numbers. **Local Service Management System (LSMS) _ EAGLE LNP Application Processor (ELAP)** reload, audit and reconcile times increase proportionally to the size of the database. Aggregate times for **Multi-Purpose Server (MPS)** to **DSM** audit, reconcile, and reload increase slightly due to the increase in **LNP** database capacity, but the rate-per-time unit remain the same.

Hardware Requirements

The existing 4G **DSM** card is used for 120 Million **LNP** numbers.

Limitations

- This feature is only available for North American **LNP** customers.
- This feature is dependent on the **LSMS** 120 Million **LNP** number feature.
- If the Message Relay Group (**MRG**) Table exceeds 2 million entries then the Software Release Upgrade cannot occur. This is an incompatible situation and loss of data may occur if the upgrade is executed for either the **EAGLE 5 ISS** or **ELAP**.

2.17 120 SE-HSL Support (Release 46.0)

The 120 SE-HSL Support feature increases the maximum SE-High Speed Link support from 80 to 120 per **EAGLE** node. The following Feature Access Keys (FAKs) are used to support the increased number. Refer to *Commands User's Guide* for a detailed description.

- 893013012 :SE-HSL SLK Capacity :QTY=88

- 893013013 :SE-HSL SLK Capacity :QTY=96
- 893013014 :SE-HSL SLK Capacity :QTY=104
- 893013015 :SE-HSL SLK Capacity :QTY=112
- 893013016 :SE-HSL SLK Capacity :QTY=120

2.18 120M DN and 120M IMSIs via Split Database (Release 45.0)

The 120M DN and 120M IMSIs via Split Database feature, or EPAP Data Split feature, splits EPAP data into DN and IMSI subsets. Each subset of data is loaded on a specific set of E5-SM4G or E5-SM8G-B cards. Since each set can support 120 million, splitting the data allows a system-wide EPAP data capacity of 240 million.

After the EPAP Data Split feature is turned on, the `chg-card` command is used to designate E5-SM4G and E5-SM8G-B cards as either DN or IMSI cards. The DN, DN Block, ASD and Entity data will be loaded on the DN card, and the IMSI, IMEI, IMEI block, and Entity data will be loaded on the IMSI card.



Note:

For the complete list of cards supported by EAGLE Release 47.0, see Hardware Reference Guide.

2.18.1 Feature Control Requirements

- FAK for Part Number 893-0398-01
- A temporary FAK cannot be used to enable the feature.
- The feature cannot be turned off after it is turned on.
- The EPAP Data Split feature requires EPAP 15 or higher.
- Message Flow Control must be turned on before the EPAP Data Split feature can be enabled.
- At least one EPAP-related feature must be turned on before the EPAP Data Split feature can be enabled.
- E5-SM4G or E5-SM8G-B cards must be present in the system before the feature can be enabled.
- The feature cannot be enabled if a DSM, E1-ATM, E1T1-MIM, LIM-ATM, or MPL card is equipped and running in the system.

2.18.2 Hardware Requirements

E5-SM4G or E5-SM8G-B cards must be running in the system before the EPAP Data Split feature can be enabled. If a DSM card is running, then the feature cannot be enabled.

If a DSM, E1-ATM, E1T1-MIM, LIM-ATM, or MPL card is installed after the EPAP Data Split feature is turned on, then the card will auto-inhibit.

2.19 120M DNs plus 120M IMSIs via Split Database (EPAP 15.0)

The 120M DNs and 120M IMSIs via Split Database feature is supported in EPAP 15.0 and EAGLE Release 45.0 when the EPAP Data Split feature (part number 893-0398-01) is enabled and turned on using a Feature Access Key (FAK) at the EAGLE. This feature must be turned on at both the EAGLE and the EPAP. As a permanently-on feature, the feature cannot be turned off after it is turned on.

After the EPAP Data Split feature is turned on, all Service Module cards are initialized as combined cards which contain DN and IMSI data. For the 120M DNs and 120M IMSIs via Split Database feature, a Service Module card must be configured as either a DN card or an IMSI card, using the `chg-card` command. The Service Module card configured as a DN card supports DN, DN Block, ASD, and Entity entries. The Service Module card configured as an IMSI card supports IMSI, IMEI, IMEI Block, and Entity entries. The 120M DNs and 120M IMSIs via Split Database feature requires E5-SM4G or E5-SM8G-B Service Module cards (E5-SMxG cards). The 120M DNs and 120M IMSIs via Split Database feature is not supported on DSM Service Module cards.

The 120M DNs and 120M IMSIs via Split Database feature expands the EPAP capacity from 120 million to 240 million database entries with a combined maximum of 120 million DNs and 120 million IMSIs. The DN count is independent of the IMSI and IMEI count. The DN entries reside on a one set of Service Module cards, while the IMSI and IMEI entries reside on another set of Service Module cards. A maximum of 120 million DN entries are supported on a Service Module card configured as a DN card. The database count of 240 million entries does not include the ASD and IMEI counts. However, EPAP can support more than 240 million database entries with allowed combinations of IMSI and IMEI counts on the IMSI card and with combinations of DN and ASD counts on the DN card. A Service Module card configured as an IMSI card supports a maximum of 120 million IMSIs or the following combination of IMSIs and IMEIs.

Maximum Combinations of IMSI, IMEI entries

- 120 million, 6 million
- 112.5 million, 16 million
- 105 million, 26 million
- 97.5 million, 32 million

2.20 192 Million LNP Numbers (Release 34.0, ELAP 5.0)

Description

The 192 Million **LNP** Numbers Support feature expands the maximum number of ported/pooled **Local Number Portability (LNP)** numbers supported on one EAGLE 5 ISS platform to 192 million **LNP** numbers. The feature supports feature access keys for 132, 144, 156, 168, 180, or 192 million ported/pooled numbers.

Configurable alarm thresholds indicate:

- When the transactions-per-second (**TPS**) for the EAGLE 5 ISS (as a whole) reaches the threshold value.

- When the number of **LNP** ported **TNs** and **LRNs** in the database is approaching the configured percent of the enabled maximum number allowed in the database.
- When the thermal limits of an **HC-MIM** card have been reached.

The 192 Million **LNP** Numbers Support feature requires the **ELAP 5.0** database application. The **ELAP 5.0** database application is installed and runs on the T1100 application server.

Hardware Requirements

The existing 4GB **DSM** card must be used for the 192 Million **LNP** Numbers feature.

The **ELAP 5.0** database application that supports 192 million **LNP** numbers runs on the T1100 platform.

Limitations

- The 192 Million **LNP** Numbers feature is available only for North American **LNP** customers.
- This feature requires the **LSMS 192 Million LNP** Numbers feature.
- Prior to the upgrade, Tekelec will perform a pre-upgrade health check to access the compatibility of your current hardware and software configuration. If the Message Relay Group (**MRG**) table exceeds 2 million entries, the Software Release Upgrade cannot occur. This is an incompatible situation, and a loss of data may occur if the upgrade is executed for either the EAGLE 5 ISS or **ELAP**.
- 192 Million **LNP** Numbers feature activation on the EAGLE 5 ISS is based on the following conditions:
 - The **ELAP LNP** Configuration feature access key must be on.
 - 4-Gigabyte **DSMs** are required; at least one 4-Gigabyte **DSM** must be provisioned in the system.
 - The **ELAP** software version must be **ELAP 4.0** if an EAGLE 5 ISS feature access key for 96-120 Million **LNP** Numbers is enabled.
 - The **ELAP** software version must be **ELAP 5.0** if an EAGLE 5 ISS feature access key for more than 120 Million **LNP** Numbers is enabled.

2.21 228 Million LNP Numbers (ELAP 6.0)

Description

As **Local Number Portability** becomes more established, competition increases, and number pooling becomes more widespread, the number of ported **TNs** continues to increase. Customers would like to manage a single **LSMS** that is capable of maintaining the national **LNP** database. Increased capacity is required on the **ELAP**.

Currently, Tekelec supports 192 Million **LNP** numbers per node on a 4 **GB DSM** card. With the advent of wireless portability and continued wireline **LNP** porting and pooling activity, it is anticipated that the 192 Million **LNP** numbers capacity will be exceeded sometime early-mid 2007 as shown in Figure FN-1.

Figure 2-5 Current LNP Growth Projections

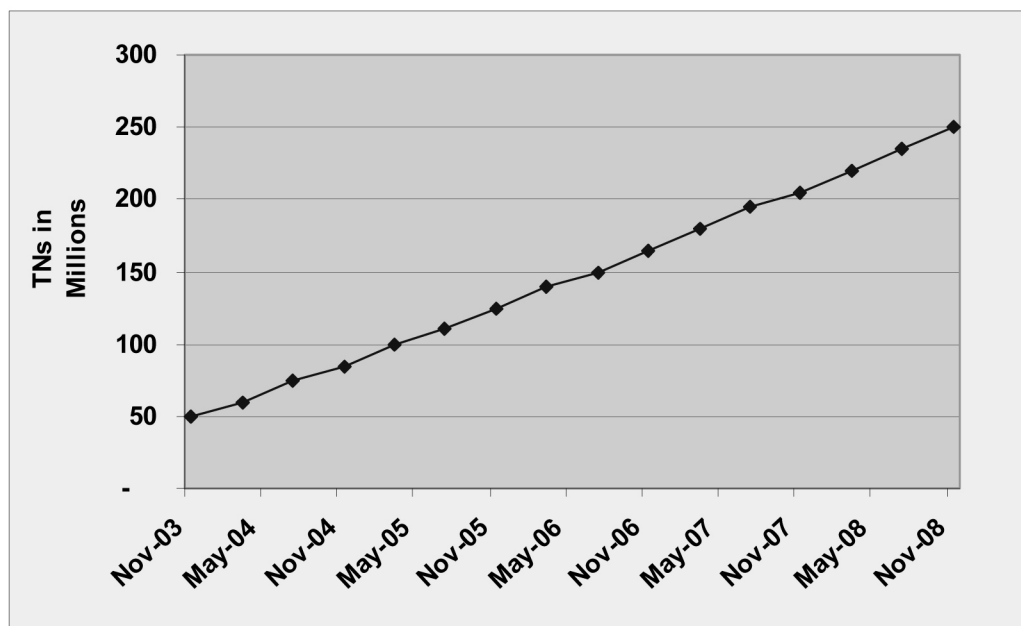

The 228 Million **LNP** Numbers feature allows customers to use their existing hardware and remain in a centralized Eagle **LNP** architecture (all **LNP** numbers in one node).

The 228 Million **LNP** Numbers feature expands the maximum number of ported/pooled **LNP** numbers supported on one **EAGLE** node to 228 million **LNP** numbers in increments of 12 million numbers. Additional database improvements include faster **MPS-to-DSM** audit reconcile and reload times, and **LSMS-to-ELAP** audit times.

The 228 Million **LNP** Numbers feature expands the maximum number of ported/pooled **Local Number Portability (LNP)** numbers supported on one on the **ELAP** to 228 Million **LNP** Numbers. The feature supports feature access keys for increments from 204, 216, or 228 million ported/pooled numbers across all **NPAC** regions.

Hardware Requirements

The 228 Million **LNP** Numbers feature requires the existing 4 **GB DSM** card.

The 228 Million **LNP** Numbers feature runs on the T1100 platform.

Limitations

The 228 Million **LNP** Numbers feature is available only for North American **LNP** customers.

The 228 Million **LNP** Numbers feature requires the **LNP** 228 Million numbers feature on the **LSMS**.

2.22 228 Million LNP Numbers (Release 35.0)

Description

The 228 Million **LNP** Numbers feature allows the capacity of an **EAGLE** 5 ISS node to increase to 228 million **LNP** numbers without adding new hardware.

The increase is achieved by using existing 4GB DSM cards and enhancing the database. EAGLE 5 ISS supports the following feature access keys for LNP growth beyond 120 million LNP numbers on the existing 4GB DSM card:

- 132 Million LNP – 893-0110-15
- 144 Million LNP – 893-0110-16
- 156 Million LNP – 893-0110-17
- 168 Million LNP – 893-0110-18
- 180 Million LNP – 893-0110-19
- 192 Million LNP – 893-0110-20
- 204 Million LNP – 893-0110-21
- 216 Million LNP – 893-0110-22
- 228 Million LNP – 893-0110-23

The 228 Million LNP Number feature must be activated on the LSMS, ELAP, and EAGLE 5 ISS products. LSMS 8.5 and ELAP 6.0 with 228 Million LNP Numbers support are required to enable the feature on EAGLE 5 ISS.

Hardware Requirements

The 228 Million Numbers LNP feature has the following hardware requirement:

- The existing 4GB DSM card must be used for the 192 Million LNP Numbers feature.
- The ELAP 5.0 database application that supports 192 million LNP numbers runs on the T1100 platform.

Limitations

The 228 Million LNP Numbers feature has no limitations.

2.23 384 Million LNP Records (Release 39.0, ELAP 8.0)

The 384 Million LNP Records feature is a quantity feature that increases the LNP capacity from 228 million LNP numbers and number pool blocks to 384 million LNP numbers and number pool blocks per EAGLE 5 ISS node.

This feature also provides up to 200 thousand location routing numbers (LRNs) and 350 thousand numbering plan area and exchange (NPA-NXX) numbers on a single node.

The 384 Million LNP Records feature is an EAGLE 5 ISS feature. However, the feature interacts with the ELAP and LSMS systems. All of the systems must be at the required release before the 384 Million LNP Records feature can be enabled.

For information on the ELAP component of the 384 Million Records feature, refer to the *ELAP Administration Manual* of your EAGLE 5 ISS Release 39.0 documentation set. For information on the LNP component, refer to the *LNP Feature Activation Guide*.

2.23.1 Feature Control Requirements

The 384 Million LNP Records feature has the following feature control requirements:

- The LSMS, EAGLE 5 ISS, and ELAP systems must be running at the required release levels.
- The 384 Million Records feature for the LSMS must be turned on before the 384 Million LNP Records feature for the EAGLE 5 ISS can be enabled.
- The 384 Million LNP Records feature is a quantity feature. The numbers of LNP records are increased beyond 228 million in increments of 12 million. A FAK for the part number corresponding to the desired increment is required:
 - 893-0110-24: 240 million
 - 893-0110-25: 252 million
 - 893-0110-26: 264 million
 - 893-0110-27: 276 million
 - 893-0110-28: 288 million
 - 893-0110-29: 300 million
 - 893-0110-30: 312 million
 - 893-0110-31: 324 million
 - 893-0110-32: 336 million
 - 893-0110-33: 348 million
 - 893-0110-34: 360 million
 - 893-0110-35: 372 million
 - 893-0110-36: 384 million
- A temporary FAK cannot be used to enable the feature.
- The feature cannot be turned off after being turned on.
- After the feature is turned on, a feature that provides a lower number of records cannot be enabled and turned on.

2.23.2 Hardware Requirements

The hardware requirements for the 384 Million LNP Records feature varies depending on the quantity that is enabled and the version of ELAP that is used.

Table 2-4 Hardware Compatibility Matrix

Quantity FAK Enabled	ELAP 7.0 or Less	ELAP 8.0
<= 192M	Service Module cards	E5-SM4G cards
204M - 228M	DSM cards	E5-SM4G cards
>= 240M	N/A	E5-SM4G cards



Note:

Quantities of >228M require ELAP 8.0 and LSMS 11.0.

**Note:**

Total system TPS capacity cannot exceed 40,000 TPS when E5-SM4G cards are used.

2.23.3 Limitations

No limitations are associated with this feature.

2.24 500 SS7 Links (Release 21.0)

In Release 21.0, the maximum number of **SS7** signaling links the **EAGLE** can contain is being increased from 268 to 500. For the EAGLE to contain 500 **SS7** signaling links (a maximum of 250 **LIMs**), the system configuration has been increased from 3 frames to 6 frames. Each frame can contain 3 shelves, with the exception of the last frame which can contain only 1 shelf, for a maximum of 16 shelves. The numbering of the shelves is 1100 to 6100. This provides card location numbers from 1101 to 6118. Also in Release 21.0, card locations 1111 and 1112 are also configurable in the database. The following table shows the new numbering scheme for card locations.

Table 2-5 Release 21.0 Card Location Numbering Scheme

Frame	Shelf 1	Shelf 2	Shelf 3
Frame 1	1101 - 1108, 1111 - 1118	1201 - 1208, 1211 - 1218	1301 - 1308, 1311 - 1318
Frame 2	2101 - 2108, 2111 - 2118	2201 - 2208, 2211 - 2218	3201 - 3208, 3211 - 3218
Frame 3	3101 - 3108, 3111 - 3118	2301 - 2308, 2311 - 2318	3301 - 3308, 3311 - 3318
Frame 4	4101 - 4108, 4111 - 4118	4201 - 4208, 4211 - 4218	4301 - 4308, 4311 - 4318
Frame 5	5101 - 5108, 5111 - 5118	5201 - 5208, 5211 - 5218	5301 - 5308, 5311 - 5318
Frame 6	6101 - 6108, 6111 - 6118	Not Equipped	Not Equipped

As a result of the change in the system configuration, the range of values specified for any command that uses the card location or the shelf location as a parameter (the `loc` parameter) have been changed. These commands are:

Table 2-6 Commands Changed for 500 SS7 Links

<code>act-dlk</code>	<code>act-file-trns</code>	<code>act-lpo</code>	<code>act-slk</code>
<code>alw-card</code>	<code>alw-slk</code>	<code>blk-slk</code>	<code>canc-dlk</code>
<code>canc-lpo</code>	<code>canc-slk</code>	<code>cdu</code>	<code>chg-bip-fld</code>
<code>chg-bip-rec</code>	<code>chg-x25-rte</code>	<code>chg-x25-slk</code>	<code>conn-imt</code>
<code>dact-slk</code>	<code>disc-imt</code>	<code>disp-bip</code>	<code>disp-bp</code>

Table 2-6 (Cont.) Commands Changed for 500 SS7 Links

disp-disk-dir	disp-fta-dir	disp-lba	disp-mem
dlt-bp	dlt-card	dlt-dlk	dlt-fta
dlt-ip-node	dlt-shlf	dlt-slk	ent-bp
ent-card	ent-dlk	ent-ip-node	ent-shlf
ent-slk	ent-x25-rte	inh-card	inh-slk
init-card	rept-meas	rept-stat-card	rept-stat-db
rept-stat-dlk	rept-stat-slk	rept-x25-meas	rmv-card
rst-card	rtrv-bip	rtrv-card	rtrv-dlk
rtrv-ip-node	rtrv-obit	rtrv-shlf	rtrv-slk
rtrv-trbl	rtrv-x25-rte	rtrv-x25-slk	send-msg
set-mem	tst-bip	tst-dlk	tst-slk
ublk-slk	unhb-slk		

If the **EAGLE** is using the gateway screening, global title translation, X.25 gateway, or **STP LAN** features, the card requirements to support these features will reduce the maximum number of **SS7** signaling links the **EAGLE** can contain. The card requirements for these features are:

- For the gateway screening feature, the **EAGLE** can contain a maximum of 8 **ASMs** running the `gls` application.
- For the global title translation feature, the **EAGLE** can contain a maximum of 25 **ASMs** running the `sccp` application.
- There can only be one X.25 signaling link assigned to a **LIM**.
- For the **STP LAN** feature, the **EAGLE** can contain a maximum of 20 **ACMs**.

2.25 504 Million LNP Entries (Release 10.1)

This feature increases the capacity from 384 Million to 504 Million Telephone Number (TN) or Number Pool Block (NPB) records. This feature also removes incremental capacity control in ELAP. This feature increases the TN count; the maximum allowed count for all other data types remains unchanged:

Table 2-7 Max Data

Value	LNP 384M Solution	LNP 504M Solution
TN	384,000,000	504,000,000
NpaNxx	350,000	350,000
Lrn	200,000	200,000
Mr	2,000,000	2,000,000
LrnMr	2,000,000	2,000,000
OGTT	200,000	200,000

The default system capacity is 120M. The user is be able to configure the system capacity to 504M by setting the `MAX_RECORDS` feature value to 504 on the LSMS.

See *Administration and LNP Feature Activation User's Guide* for more information on configuring quantity keys.

2.25.1 Hardware Requirements

This feature requires the following hardware:

- Two (2) E5-APP-B cards (either -01 or -02) to make an ELAP pair
- Two (2) E5-APP-B -02 cards to make an LSMS pair
- SMxG card(s) at the EAGLE

2.26 1100 TPS/DSM for ITU NP (Release 36.0)

Description

The 1100 TPS/DSM for ITU NP feature allows a DSM card to support up to 1100 transactions per second (TPS) for the EAGLE 5 ISS G-Port, A-Port, INP, IS41 GSM Migration, EIR, and ANSI-41 INP Query features.

The **1100 TPS/DSM for ITU NP** feature increases the **TPS** capacity of each **DSM** card from the current 850 **TPS** to 1100 **TPS** per card when an **EPAP**-based **ITU** feature (**G-Port**, **G-Flex**, **INP**, **EIR**, **Prepaid IDP Query Relay**, **A-Port**, **IS41 GSM Migration**, or **AINPQ**) has been turned on. Increasing the **TPS** of each card increases the maximum capacity of an **EAGLE 5 ISS**, with 25 **DSM** cards in a 24 + 1 configuration, from 20,400 to 26,400 **TPS**. (The capacity of a **DSM** card is rated at 1700 **TPS** when features requiring **EPAP**-based database lookup have not been enabled or turned on.) In most systems, only 50% or less of the traffic needs an **EPAP**-based database lookup while the rest of the traffic requires **GTT**-related database lookup. The **1100 TPS/DSM for ITU NP** feature assumes that at most 70% of the traffic shall require **EPAP**-based database lookup.

A feature access key (**FAK**) for part number 893018001 is required to enable this feature.

- A temporary **FAK** is not allowed for this feature.
- This feature is an **ON/OFF** feature, it can be turned on and off after it has been enabled.
- At least one **EPAP**-based **ITU** feature (**G-Port**, **G-Flex**, **INP**, **EIR**, **Prepaid IDP Query Relay**, **A-Port**, **IS41 GSM Migration**, or **AINPQ**) must be on before this feature can be enabled.
- The **ansigflex STP** option cannot be used when this feature is enabled; this feature cannot be enabled when the **ansigflex STP** option is used.

Hardware Requirements

The **1100 TPS/DSM for ITU NP** feature requires **DSM** cards running the **VSCCP** application

Limitations

When the **1100 TPS/DSM for ITU NP** feature is on and more than 70% of the traffic requires **EPAP**-based database lookup, the **DSM** cards provisioned in the system for **SCCP** might not be able to support 1100 **TPS**.

2.27 2500 Routing Keys (IP7 Release 7.1)

Description

This feature increases the total number of routing keys on a **SSEDCM IPGWx** application from 1000 routing keys to 2500, while retaining the **DCM IPGWx** application to a maximum of 1000 routing keys. The total number of routing keys for each application may be all dynamic, all static, or a combination of both.

The **SG** supports two types of routing keys for use by the **IPGWx** application, Static Routing Keys and Dynamic Routing Keys. Both routing keys are stored in one routing key table which is located in **RAM** on the **IPGWx** application.

- Static Routing Keys. These routing keys are provisioned via administration commands and are stored in the **OAM** static database. The **SS7IPGWx** application keeps a copy of the static routing keys in the **SS7 Routing Key** Table on-board in **RAM** for quick access.
- Dynamic Routing Keys. Dynamic Routing Keys are provisioned via a request sent over an **IP** connection and allows an **IP** connection to automatically direct traffic towards (or away from) themselves by sending messages to the Signaling Gateway.

Note that all **IP** connections (**TALI/TCP**, **M3UA/SCTP** and **SUA/SCTP**) on the **IPGWx** application use routing keys. Currently, only **TALI** sockets have the capability to create dynamic routing keys via dynamic registration. However, this feature makes no assumptions regarding an **IP** connection's ability to register dynamic routing keys.

New Auto-inhibit Facility

The System Configuration Manger (**SCM**) software is responsible for determining if the proper **GPL** should be fully loaded onto the requested card. For **IPGWx** applications, the **SCM** software will now calculate the sum of the **CHG-SG-OPTS** command parameters **:SRKQ** and **:DRKQ** to see if the total is over 1000.

If the sum is over 1000 and the **IPGWx** application board is a **DCM**, the card will be *automatically inhibited*, and the alarm message Insufficient memory for provisioning will be displayed. When a **DCM IPGWx** card is auto-inhibited, it will remain inhibited, unless the following sequence of events occurs.

- The number of routing keys on all **IPGWx** applications must be reduced to 1000 or less.
- Once the number of routing keys is reduced to 1000, the **CHG-SG-OPTS** command must be issued such that $drkq + srkq \leq 1000$.
- The inhibited **IPGWx** card must be manually allowed.

Hardware Requirements

This feature requires the **SSEDCM**-based **IPGWx GPLs** (870-2372-xx).

2.28 4000 Routesets (Release 23.0)

This feature increases the size of the routing table in the **EAGLE** database from 2000 entries to 4000 entries. With this feature turned on, the user can configure up to 4000 routesets in the database. The **EAGLE** requires that the destination point code of each routeset be entered in the database. So to enter 4000 routesets in the database, 4000 destination point codes must be entered in the database. The size of the destination point code table has been increased from 2000 destination point codes to 4000 destination point codes.

The 4000 routeset feature is activated using the `chg-feat` command. A new parameter, `DSTN4000`, has been added to the `chg-feat` command to turn the 4000 routeset feature on. Before the `chg-feat` command can be executed, the link interface modules (**LIMs**), both low-speed and high-speed, must have the proper memory installed.

All link interface modules (**LIMs**) running the `ss7ansi`, `ss7gx25`, and `ccs7itu` applications, the low-speed **LIMs**, must be equipped with one dual inline memory module (**DIMM**), containing 4 Mbytes of static **RAM**. All **LIMATMs**, the link interface module used for the high-speed **ATM** signaling link, must be equipped with two **DIMMs** providing a total of 8 Mbytes of memory. This additional memory is required so that the larger routing table can be downloaded to each **LIM**.

If the `DSTN4000` parameter is specified with the `chg-feat` command and even one **LIM** does not have the proper memory installed, the `chg-feat` command is rejected with this message, and the 4000 routeset feature will not be turned on:

2.29 5000 Routes (Release 26.1)

Some customers with large network configurations require more than 4000 routes, due to the expansion of link capability and/or collapsing networks. This feature is a continuation of route expansion for the **EAGLE** platform, and is intended to replace the 4000 route feature.

The maximum number of administered routes supported in the **EAGLE STP** has been increased from 4000 to 5000 as a system-wide option. The minimum number of x-list entries remains 500.

The **EAGLE STP** now supports, as a system-wide option, the administration and protocol changes required to support 5000 routes. The default for the routing option remains 2000 routes, and 500 x-list entries. No change in x-list capacity is required. Total routes table capacity is 5500 entries.

2.30 6000 Routesets (Release 29.0)

Description

The 6000 Routesets feature expands the **SS7** routing connectivity between the **EAGLE** and other nodes by increasing the number of routesets supported by the **EAGLE**. This allows for the **EAGLE** to function in larger **SS7** networks.

The functionality of this feature applies to all **LIM** types except **LIMs** running the **GX25 GPL**, which will continue to utilize the X.25 2000 Routeset feature. However, the increased 6000 **SS7** routeset table will also be downloaded on **GX25** card.

 **Note:**

There is a feature access key for the 6000 Routeset feature. It can not be activated unless the 5000 routeset feature bit is **ON** and the active and standby **OAM** is a **GPSM-II** running the **EOAM GPL**.

Hardware Requirements

This feature requires the **GPSM-II** in the active and standby **OAM** slot, and a **TDM** change (870-0774-10 or later).

 **Caution:**

Never install or initialize **MCAP** cards in **MASP** slots 1113 and 1115 after features that require **GPSM-II** cards are provisioned. Attempting to initialize **MCAP** cards with **GPSM-II** features provisioned will cause a system outage. Before replacing an existing **GPSM-II** card in a **MASP** slot (1113 and 1115) contact Tekelec Customer Service.

2.31 8,000 Routesets (Releases 31.8, 34.0)

Description

The 8,000 Routesets feature expands the **SS7** routing connectivity between the EAGLE 5 ISS and other nodes by increasing the number of routesets supported by **EAGLE 5 ISS** from 6000 to 8000. This feature can be viewed as an extension to the 6000 Routesets feature, which expanded the EAGLE 5 ISS routesets from 5000 to 6000.

A **Feature Access Key (FAK)** allows the customer to set the routeset limit to either 7000 or 8000. With the exception of a routeset provisioning limit imposed by the 7000 FAK, the 7000 Routeset and 8000 Routeset implementations are identical.

Limitations

If the customer has more than 8000 aliases provisioned, then the 7000 or 8000 Routesets feature cannot be enabled. Aliases must be deleted from the system until the 8000 alias limit is met.

Hardware Requirements

The 8000 Routesets feature permits customers to add additional routesets without requiring hardware change.

2.32 10,000 Routesets (Release 43.0)

The 10,000 Routesets feature allows up to 10,000 routesets or destinations to be provisioned on the EAGLE 5 ISS. The maximum number of supported aliases and exception list entries are increased to 10,000, each. The maximum number of supported normal and exception routes (combined) is increased to 10,000.

An additional 500 entries continue to be supported for dynamically-created exception list entries. These entries are available only if the Cluster Routing feature is turned on.

2.32.1 Feature Control Requirements

- FAK for Part Number 893-0064-05
- The 5000 Routesets feature must be turned on before the 10,000 Routesets feature can be enabled.
- The Cluster Routing feature must be turned on before the additional 500 entries that are reserved for dynamically-created entries are available.
- A temporary FAK cannot be used to enable the 10,000 Routesets feature.
- The 10,000 Routesets feature cannot be turned off after being turned on.

2.32.2 Hardware Requirements

The 10,000 Routesets feature is supported on all cards except EOAM cards.

2.33 40,000 GTT Capacity (Release 28.0) (IP⁷ Release 6.0)

The **EAGLE** currently supports a maximum of 20,400 **GTT**/sec/system. For many customers, this **GTT** capacity is insufficient. This is especially true for customers who use a single node, or a single pair of nodes, to centralize **GTT** for their entire network. This feature allows the **EAGLE** to process a minimum of 40,800 **GTT**/sec/system.

The 40,000 **GTT** Capacity feature assumes the use of **DSM** cards for **GTT** functionality.

For more information on the **GTT** feature, refer to the *Database Administration Manual - Features*.

2.34 50,000 GTT Capacity (Release 35.1)

Description

The 50,000 **GTT** Capacity feature increases the **GTT** processing capability of EAGLE 5 ISS **GTT**-only nodes from 40,800 **TPS** to 52,700 **TPS** through the use of 32 **DSMs** per node (31 active and 1 for +1 redundancy), each running at 1700 **TPS** per card (31 x 1700 = 52,700).

Hardware Requirements

The 50,000 **GTT** Capacity feature requires 32 **DSM** cards exclusively for **GTT** functionality.

Limitations

The 50,000 **GTT** Capacity feature has the following limitations:

- The **LNP**, **G-Flex**, **G-Port**, **INP**, or **EIR** features cannot be activated if there are more than 25 **DSM** cards in the system. Therefore, these features are not supported in conjunction with the 50,000 **GTT** Capacity feature.
- The maximum number of **SCCP** cards allowed in a single **EAGLE 5 ISS** node is 32 (to provide n+1 functionality). 32 **DSM** cards are required to achieve 52,700 **TPS**; therefore, if any **TSM** cards are in the system, the total **TPS** rate will be less than the system maximum.
- The 50,000 **GTT** Capacity feature is not available on systems that are equipped with **MPS**.

2.35 65,535 Entries per Translation Type (Release 22.0)

This feature improves the performance of the global title translation subsystem of the **EAGLE** to these levels.

- 850 messages per second
- 21,000 global title translations per second per system
- 65,536 entries per translation type

There is no mechanism to limit the number of global title translation entries to less than 65,537 per translation type. The maximum number of entries in the global title translation table has not changed and is still 270,000 entries. It is possible to enter all 270,000 entries under one translation type. The performance of the global title translation subsystem is not guaranteed when more than 65,536 translations are entered for a single translation type.

The `rtrv-gtt` command output has been changed to show the capacity of the global title translation table is as a percentage of the total number of entries in the system (270,000 entries).

2.36 150,000 GTT TPS and 75,000 EPAP TPS (Release 37.0)

Description

The 150,000 **GTT** TPS feature increases the throughput capacity of the **EAGLE 5 ISS** from 52,700 to 150,000 **TPS** for a node in which the **SCCP** message throughput traffic is processed by the **GTT** feature.

The 75,000 **EPAP** TPS feature increases the throughput capacity of the **EAGLE 5 ISS** from 20,400 to 75,000 **TPS** for a node that processes part of the **SCCP** message throughput traffic by one or more of the **EPAP**-based features (e.g. **G-Port**, **G-Flex**, **EIR**, or **INP**) or for a node that processes a combination of **GTT** and **EPAP** traffic.

These features require the **E5-SM4G** card to be installed in the **EAGLE 5 ISS**. The **E5-SM4G** Throughput Capacity feature must be enabled and turned on in order to operate at 5000 **TPS** (if traffic is processed by **GTT**) or 3125 **TPS** (if traffic is processed by the **EPAP**-based features).

To achieve the maximum **TPS** rates, the following conditions must be met:

- All of the **DSM** cards must be replaced with **E5-SM4G** cards.

- The E5-SM4G Throughput Capacity feature must be enabled and turned on.

If all of the SCCP traffic is processed by GTT, then a maximum of 32 E5-SM4G cards can be provisioned in the EAGLE 5 ISS. If the E5-SM4G Throughput Capacity feature is enabled and turned on, then each E5-SM4G card can process traffic at a rate of 5000 TPS, and the 150,000 TPS rate can be reached.

If any of the SCCP traffic is processed by an EPAP-based feature, then a maximum of 25 E5-SM4G cards can be provisioned in the EAGLE 5 ISS. If all of the SCCP traffic is processed by EPAP-based features, and if the E5-SM4G Throughput Capacity feature is enabled and turned on, then the rate of 75,000 TPS can be reached.

E5-SM4G cards can co-exist with DSM cards in the EAGLE 5 ISS; however, if both kinds of cards are used, then the maximum TPS rates cannot be reached.

Feature Control Requirements

The E4-SM4G Throughput Capacity feature has the following feature control requirements:

- A FAK for part number 893-0191-01
- A temporary key cannot be used to enable the E5-SM4G Throughput Capacity feature.
- After the E5-SM4G Throughput Capacity feature has been turned on, it cannot be turned off.
- The E5-SM4G Throughput Capacity feature cannot be enabled if any of the following features or options are turned on:
 - E5IS (EAGLE 5 Integrated Monitoring) feature
 - LNP feature
 - ANSIGFLEX STP option

Hardware Requirements

The E5-SM4G Throughput Capacity feature requires HIPR cards to be installed in all the shelves in an EAGLE 5 ISS node.

Limitations

The 150,000 GTT TPS and 75,000 EPAP TPS features have the following limitations:

- The real time database entry capacity of the E5-SM4G card for the EPAP-based features is smaller than the capacity supported by the current DSM 4G card.
- If the E5IS IMF or LNP feature, or the ANSIGFLEX system option is enabled, then the TPS level is held to the level of a DSM card (1700 TPS). The E5-SM4G Throughput Capacity feature cannot be enabled, and the 150,000 GTT TPS feature cannot be used.

2.37 Ability to Change System Required User Passwords (ELAP 9.0)

With the ability to support many users comes the need for tighter security. The user interface addresses security concerns with various restrictions and controls. In many

cases, the frequency or severity of these checks is configurable by the administrator at both a user specific and system-wide level.

The Ability to Change System Required User Passwords feature in ELAP 9.0 implements the following password rules and requirements:

- New password requirement for viewing logs.
- Stricter password complexity rules, with password complexity required.
- Stricter password aging rules.
- Stricter password reuse rules.
- New requirement to enter the password for `elapdev` User ID on the Copy RTDB from Remote screen.

2.38 Ability to Change System Required User Passwords (EPAP 14.0)

The Ability to Change System Required User Passwords feature enhances the EPAP Graphic User Interface (GUI) to increase security restrictions and controls. The frequency and severity of these controls is can be configured by the administrator at user-specific level and system-wide levels.

Security enhancements include a new password requirement for viewing logs. The `appuser` user is the only user authorized to view logs and must supply a password to view the logs. In addition, strict password complexity, password aging, and password reuse rules are introduced.

Password Complexity

Password complexity rules for user passwords implemented by EPAP 14.0:

- The password cannot exceed 100 characters in length.
- The password must include at least one alpha character.
- The password must include at least one numeric character.
- The password must include at least one special punctuation character: question mark (?), period (.), exclamation point (!), comma (,), or semicolon (;).
- The password cannot contain three or more of the same alphanumeric or special punctuation character in a row.
- The password cannot contain three or more consecutive ascending alphanumeric characters in a row.
- The password cannot contain three or more consecutive descending alphanumeric characters in a row.
- The password cannot contain the user account name (login name).
- The password must not contain the user account name in reverse character order.
- The password must not be blank or null.
- The password must not be a default password.



Note:

The option to enforce or not enforce password complexity has been removed.

Password Aging

Users can be forced to change their passwords after a certain number of days. The administrator can set a maximum password age of up to 180 days as a default for the system and can specify a different maximum password age for any individual user.

Password Reuse

Users cannot reuse their last N passwords, where N is a system-wide configurable number from 3 to 99, with a default of 5. The administrator cannot turn off this restriction by setting N to 0 (zero).

2.39 Ability to Configure a Single EPAP Server (Release 16.2)

This feature supports the configuration of EPAP on a single setup. This feature allows the user to perform disaster recovery on mixed/non-prov setup and other to configure the EPAP on single setup.



Note:

This feature is not supported on PDBonly setup.

This feature eliminates the manual steps required for the Network Configuration. Instead, a menu option is provided in the epapconfig menu that allows the user to perform disaster recovery that performs the network configuration.

See the "Configure Mate Disaster Recovery" section in *Administration Guide* for more information.

2.40 Additional DRA values for INP formatting (Release 43.0)

The existing INP (Part Number 893-0179-01) and AINPQ (Part Number 893-0178-01) features are enhanced to support additional DRA values:

- GRN
- GRN+DN
- CC+GRN+DN

2.41 Additional Integrated Sentinel Support (Release 28.2)

Description

This feature adds the following **EAGLE** cards to those supported by the **EAGLE** with **Integrated Sentinel** Feature introduced in **EAGLE** Release 28.0. Sentinel 8.1 supports monitoring for links on **E1-ATM** and **LIM-ATM** cards, and supports **SS STC** cards for monitoring:

- **E1-ATM** - With Release 28.2, the **EAGLE** supports **Integrated Sentinel** functionality for the **E1-ATM** card.
- **LIM-ATM** - With Release 28.2, the **EAGLE** supports **Integrated Sentinel** functionality for the **LIM-ATM** card.
- **SS STC** - With Release 28.2, the **EAGLE** supports the existing Sentinel routing functionality (**EROUTE GPL**) on a **SS STC** card.

New Hardware Required

No new hardware is required for this feature. Note, however, that the **EAGLE** with **Integrated Sentinel** feature does require the use of **GPSM-II** cards in place of **MCAP** cards, and **HMUX** cards in place of **IPMX** cards. Also, the **EAGLE** Time Synchronization feature must be active in conjunction with this feature. In addition, the timing requirements include the use of an external Bits clock.

Caution:

Never install or initialize **MCAP** cards in **MASP** slots 1113 and 1115 after features that require **GPSM-II** cards are provisioned. Attempting to initialize **MCAP** cards with **GPSM-II** features provisioned will cause a system outage. Before replacing an existing **GPSM-II** card in a **MASP** slot (1113 and 1115) contact Tekelec Customer Service.

2.42 Add GTT on SLIC IPSG [6500] (Release 46.5)

This feature ports GTT functionality to SLIC IPSG cards. A new IPSG32 GPL combines GTT and IPSG capabilities to the SLIC card.

In order to load the new combined GPL (IPSG32), a SLIC card must be flashed with 32-bit flash (BLSLC32), and provisioned with `type=slic, appl=ipsg, and data=gtt`.

 **Note:**

The TPS performance was increased from 6,500 to 10,000 via an enhancement that is also part of EAGLE 46.5. The GTT throughput provided by LIM (IPSG) cards is limited to 400K. Since each GTT-enabled SLIC IPSG card supports 10K TPS, up to 40 GTT-enabled SLIC IPSG cards can be supported on a node.

The GTT throughput of 400K provided by LIM cards is counted separately from the SCCP SM subsystem throughput. The `rept-stat-sccp` command is enhanced to display the GTT statistics on GTT on LIM cards.

See [#unique_92/unique_92_Connect_42_V6671712](#) for the enhancement bug details, and *Commands User's Guide* for `rept-stat-sccp` details.

2.42.1 Hardware

The Add GTT on SLIC IPSG [6500] functionality only runs on SLIC cards with a 32-bit BLSLC32 flash GPL.

The following table describes hardware and provisioning combinations for IPSG cards:

Table 2-8 Supported Card Types for the IPSG Application

Card Provision Type/GTT ON/OFF	ENET-B/32-bit BLMCAP OR ENET-A	SLIC/32-bit BLSLC32	SLIC 64-bit BLSLC64
ENET/ENETB (GTT cannot be enabled on ENET/ENETB card type)	Supported Loads IPSG GPL	Supported (will work as IPSG card with the ENETB card type) Loads IPSG GPL	Auto-Inhibit (HW Verification Code 174)
SLIC with GTT disabled (DATA=NOSCCP)	Not Supported (Card will Auto-inhibit) (HW Verification Code 172)	Supported (will work as a GTT disabled IPSG card with the card type SLIC) Loads IPSG GPL	Auto-Inhibit (HW Verification Code 174)
SLIC with GTT enabled (DATA=GTT)	Not Supported (Card will Auto-inhibit) (HW Verification Code 172)	Supported Loads IPSG32 GPL	Auto-Inhibit (HW Verification Code 174)

2.43 Additional PDBI Provisioning Statistics on EPAP (EPAP 15.0)

The PDBI Provisioning Statistics reports include new performance information: total number of commands with a return code of zero that successfully updated the database for the reported period. Only `ent`, `upd`, and `dlt` commands are counted in the statistics report; `rtv` commands are not included. This performance information is displayed in the report output, generated from the GUI or CLI, as *Total Number of successful PDBI commands*, as shown in the following example.

Example of Report Contents for a specified interval:

```
Average Number of PDBI Connections      = 3
Peak Number of PDBI Connections          = 10
Average system PDBI CPS                   = 78
Peak CPS                                  = 99
Total Number of successful PDBI commands = 4885
Percentage of successful PDBI commands    = 96
```

2.44 Additional Subscriber Data (Release 40.0, EPAP 12.0)

The Additional Subscriber Data (**ASD**) feature allows additional information to be provisioned for individual subscribers or ranges of subscribers. Both ASD and Generic Routing Number (**GRN**) information can be provisioned. The following features are added to support ASD and GRN information:

- **IDP Relay Additional Subscriber Data**
The IDP Relay ASD feature provides a Numbering Plan Processor (**NPP**) service action to extract ASD information from the called party (**CdPN**) and calling party (**CgPN**) lookups.
- **IDP Relay Generic Routing Number**
The IDP Relay GRN feature provides an NPP service action to extract GRN information from the CdPN and CgPN lookups.
- **TIF Additional Subscriber Data**
The TIF ASD feature allows an ASD digit string to be inserted into the CdPN of an outgoing IAM or REL ISUP message.
- **TIF Generic Routing Number**
The TIF GRN feature allows a GRN digit string to be inserted into the CdPN of an outgoing IAM or REL ISUP message. The GRN value is obtained from the RTDB.

The new TIF and IDPR features allow EPAP ASD that is associated with a specific subscriber to be inserted into either the CgPN or CdPN based on RTDB lookup

Note:

The TIF ASD and TIF GRN features are built on the services provided by the Triggerless ISUP Framework (TIF) and are considered to be TIF applications or services. Refer to the *Feature Manual - TIF* for additional information.

In addition, existing features and commands are enhanced to support ASD. For example, the IS-41 to GSM Migration Phase 1 (IGM) and GSM MAP SRI Redirect to Serving HLR features allow provisioning of new Mobile Station Routing Number (MSRN) formatting options. If a successful database lookup returns ASD as one of the entities, and if the ASD option is provisioned, then the ASD is encoded into the outgoing SRIACK message. The existing behavior for encoding messages is then followed.

2.44.1 Feature Control Requirements

The following feature control requirements impact the features that are added to support ASD and GRN information:

- The IDP Relay ASD feature requires a FAK for part number 893-0257-01.
- The IDP Relay GRN feature requires a FAK for part number 893-0256-01.
- The IDP Relay feature must be turned on before the IDP Relay ASD or the IDP Relay GRN feature can be enabled.
- The TIF ASD feature requires a FAK for part number 893-0245-01.
- The TIF GRN feature requires a FAK for part number 893-0255-01.
- The TIF Number Portability feature must be turned on before the TIF ASD or TIF GRN feature can be enabled.
- The TIF ASD, TIF GRN, IDPR ASD, and IDPR GRN features can be turned on and off.

2.45 Administrable SLTMs (Release 20.0)

This feature allows the user to configure signaling link test messages (**SLTMs**). To test the coherency of a particular link, two signaling points can transmit periodic test messages. The signaling point initiating the test selects a link to test and then transmits an **SLTM** containing a test pattern. The other signaling point responds with an echo of the test pattern contained in the **SLTM**. The intervals between transmission of signal link test messages (**SLTMs**) are controlled by the `sltm_enabled` field in a corresponding **SLTM** table record. The **SLTM** table record also controls the following:

- the length of the test pattern in the **SLTM**
- automatic generation of **SLTMs**
- generation of periodic **SLTMs** when a link is put in service

The **SLTMs** can be sent to a signaling link that is in service whenever desired.

2.46 Advanced GT Modification (Release 38.0)

The Advanced GT Modification feature (AMGTT) allows information in the SCCP calling party address (**CgPA**) to be modified as part of global title translation (**GTT**). This information includes the global title address (**GTA**), translation type (**TT**), numbering plan (**NP**), and network address indicator (**NAI**) parameters.

Note:

If the message requires SCCP Conversion, then modification to the called party address (**CdPA**) occurs even if the AMGTT feature is turned on.

2.46.1 Feature Control Requirements

The AMGTT feature has the following feature control requirements:

- The current GT Modification (MGTT) feature bit is removed immediately upon upgrade to the release that contains the AMGTT feature. This feature bit is replaced with a tiered FAK for the following part numbers:
 - FAK for part number 893-0218-01: “Advanced Global Title Modification”. If the MGTT feature is turned off before upgrade, then this FAK is used to enable CdPA and CgPA modification after upgrade.
 - Non-sellable FAK for part number 893-0218-02: “Advanced GT Modification, Called Party Only”. If the MGTT feature is turned on before upgrade, then this FAK is used to automatically allow continued use of the CdPA modification functionality after upgrade. This FAK does not allow any CgPA modification.
 - FAK for part number 893-0218-03: “Advanced GT Modification, Calling Party Upgrade”. If the MGTT feature is turned on before upgrade, then this FAK is used enable CdPA and CgPA modification after upgrade.
- If the MGTT feature is turned off before upgrade, then all AMGTT functionalities are disabled after upgrade. The CdPA and CgPA parameters cannot be modified until the “Standard” functionality (893-0218-01), is enabled and turned on.
- The GTT feature must be turned on before the “Standard” functionality (893-0218-01) can be enabled.
- If the “Upgrade” functionality (893-0218-03) is enabled, then the “CdPA Mod Only” functionality (893-0218-02) is disabled.
- The AMGTT feature, including all subsets of AMGTT functionality, cannot be turned off after it has been turned on.
- The AMGTT feature, including all subsets of AMGTT functionality, cannot be enabled with a temporary FAK.
- The CgPA modification options cannot be used until either the “Standard” (893-0218-01) or “Upgrade” (893-0218-03) AMGTT functionality is enabled and turned on.

2.46.2 Hardware Requirements

There are no additional hardware requirements for this feature.

2.46.3 Limitations

There is a limit of 150 characters allowed for the command line input. If the input combination of parameters is greater than 150 characters, then it may be necessary to provide more than one line of input to provision all the desired fields for an entry in the GTT database.

2.47 AIN LNP Message Support (Release 46.0)

The AIN LNP Message Support feature extends support of a Local Number Portability feature to allow processing AIN messages using a Mobile Number Portability database. The AIN message types are managed using a Query/Response architecture.

2.48 AINF Applique (Release 21.0)

The **AINF** is an integrated applique which supports the **DSOA**, **DSCS** and **V.35** interfaces on the same applique. The **AINF** applique can be configured as either a **DSOA**, **OCU**, or **V.35** interface from the user terminal.

2.49 AINPQ Service Portability (Release 41.1)

Service Portability support for the AINPQ feature indicates whether Service Portability applies to ANSI-41 NPREQ messages for own-network subscribers. When Service Portability is applicable, GRN digits are used in place of RN digits in the response message.

2.50 Alarm Enhancements (Release 26.0)



Note:

This is an engineering feature.

Currently, adding new **UAMs** to the system requires many modifications to the software. It requires adding **ATH** events, adding fields to the maintenance block (**MB**), changing **ATH** on the application card to set the new field in the **MB**, possibly updating the **MB** revision, and changing **SCM** to analyze the new field and generate the **UAM**.

Application Defined **UAMs** allow the application card to generate **UAMs** without modifying the **OAM** build. Initially, this capability will be given to every application using the Generic Maintenance Block. The application will then only be required to supply a message reference number (**MRN**), an output group, a device type, and element information (example: port number) to the Application Defined **UAM** software.

There will only be one Application Defined **UAM** allowed per card in the **EAGLE**. That is, only one Application Defined **UAM** may be active at any given time. Multiple Application Defined **UAMs** may be defined and sent by the application, but not simultaneously. There is only one slot in the **MB** for Application Defined **UAM**.

2.51 Allow a Mated Application to Work as Primary-Secondary and Secondary-Primary (Release 22.0)

There are two ways to load share global title translations.

1. A mated application in load shared mode.
2. Two mate applications in dominant mode. The global title translation addresses are split into two ranges such that half of the addresses translate to one mated application and the other half translates to the other.

This feature supports the second method of load sharing. This method of load sharing allows two replicated applications to load share and back each other up in the event of a network failure. Global title translation is load shared by splitting the range of global title addresses and have them work as two separate mated applications. If one application becomes prohibited, **SCCP** routing translates all the **GTT** messages in both address ranges to the mated application. The subsystem management messages (**SBR/SNR**) and **SCCP** management messages (**SSP/SSA**) are sent to the adjacent mated application and concerned signaling points.

The following example illustrates how this feature works using a split global title address range.

1. Enter two mated applications as a dominant point code/subsystem pair. In this example, mated application A is point code 001-001-001, `ssn 10`. Mated application B is point code 001-001-002, `ssn 10`.

Input Example

```
ent-map:pc=001-001-001:ssn=10:mpc=001-001-002:mssn=10 :mult=dom:adj=yes
```

This mated application pair entered as A backed up by B, automatically creates an entry of B backed up by A. Either the primary or the backup point code and subsystem can be used as the preferred destination for a global title translation range. The other point code/subsystem is treated as the backup.

2. To split the global title ranges, enter two global title translation address ranges. One range uses mated application A and the other uses mated application B.

Input Examples

```
ent-
gtt:type=10:gta=800000:egta=800555:xlat=dpcssn:ri=ssn :pc=001-001-001:ssn=
10 ent-
gtt:type=10:gta=800556:egta=800999:xlat=dpcssn:ri=ssn :pc=001-001-002:ssn=
10
```

If mated application A becomes unavailable, all global title translation traffic for both address ranges is routed to mated application B. If mated application B becomes unavailable, the specified global title translation traffic is routed to mated application A. If both point code/subsystem pairs are available, the traffic is split according to the translation type and address ranges specified. Normally, the address range is split so that mated application A receives half the translated global title translation traffic and mated application B receives the other half.

The adjacency, concerned signaling point code group, message routing under congestion and subsystem routing parameters in the `ent-map` command apply to both point code/subsystem pairs.

The table shows how **SCCP** routing and subsystem management is handled according to the mated application parameters `adj` (adjacency), `srn` (subsystem routing messages), and `mrc` (message routing under congestion).

Table 2-9 SCCP Routing and SCCP Management Actions for a Primary-Secondary and Secondary-Primary Mated Application

Event	ADJ	SRM	MRC	SCCP Routing and SCCP Management Action
Preferred application fails because an MTP_PAUSE message for its point code has been received	yes	yes	yes or no	<ol style="list-style-type: none"> 1. Send an SBR message to the next preferred application. 2. Reroute traffic to the next preferred application.
	no	yes	yes or no	<ol style="list-style-type: none"> 1. Do not send an SBR message to the next preferred application. 2. Reroute traffic to next the preferred application.

Table 2-9 (Cont.) SCCP Routing and SCCP Management Actions for a Primary-Secondary and Secondary-Primary Mated Application

Event	ADJ	SRM	MRC	SCCP Routing and SCCP Management Action
	yes or no	no	yes or no	
Previously prohibited preferred application becomes available because an MTP_RESUME message for its point code has been received	yes	yes	yes or no	<ol style="list-style-type: none"> 1. Send an SNR message to the next preferred application. 2. Route traffic back to the preferred application.
	no	yes	yes or no	<ol style="list-style-type: none"> 1. Do not send an SNR message to the next preferred application.
	yes or no	no	yes or no	<ol style="list-style-type: none"> 2. Route traffic back to the preferred application.
Receive an SSP for the preferred application that is allowed.	yes	yes	yes or no	<ol style="list-style-type: none"> 1. Send an SBR message to next the preferred application. 2. If the SSP came from the affected point code, broadcast SSP's to the list of concerned signaling point codes. 3. Reroute traffic to the next preferred application.
	no	yes	yes or no	<ol style="list-style-type: none"> 1. Do not send an SBR message to the next preferred application.
	yes or no	no	yes or no	<ol style="list-style-type: none"> 2. Send SSP's to the list of concerned signaling point codes. 3. Reroute traffic to the next preferred application.
Receive an SSA for the preferred application that is prohibited.	yes	yes	yes or no	<ol style="list-style-type: none"> 1. Send an SNR message to the next preferred application. 2. Send SSA's to the list of concerned signaling points. 3. Reroute traffic to the next preferred application.
	no	yes	yes or no	<ol style="list-style-type: none"> 1. Do not send an SNR message to next preferred application.
	yes or no	no	yes or no	<ol style="list-style-type: none"> 2. Send SSA's to the list of concerned signaling points. 3. Reroute traffic to the next preferred application.
Preferred application becomes congested.	yes or no	yes or no	no	<ol style="list-style-type: none"> 1. Do not reroute messages to the next preferred application.

2.52 Allow MOBR Exception Routes to Adjacent Point Codes (Release 44.0)

The Origin-Based MTP Routing (MOBR) feature is enhanced to allow exception routes to be provisioned for adjacent point codes (APCs).

Exception routes are allowed through the use of a 'dummy' point code as an APC. After the true APC is replaced by a dummy APC, MOBR exception routes can be configured for the true APC with the same method used for non-adjacent destinations.

The dummy point code is configured and known only to the EAGLE 5.

The linkset to the dummy point code should have the SLTSET set to 0, using the `ent-ls` or `chg-ls` command. The `sltset` parameter specifies the SLT record to be associated the linkset. If a value of 0 is provisioned for the `sltset` parameter, then a dummy SLTSET is created and designated as 'Reflect'.

If the SLTSET for a linkset is configured as Reflect, then the EAGLE 5 does not send an SLTM message to the adjacent node. When an SLTM message is received, the EAGLE 5 responds with an SLTA message with the OPC and DPC of the SLTA swapped from the SLTM message.

2.52.1 Feature Control Requirements

The `sltset=0` parameter can be configured only for an 'A' linkset.

2.52.2 Limitations

The following limitations exist for a linkset with an SLTSET that is provisioned as *reflect*:

- SLT failures are not reported.
- Periodic SLT messages are not generated for links in the linkset.
- Peer-to-peer network management messages generated by the EAGLE 5 towards an adjacent node are not processed by adjacent nodes configured as the dummy point code. Incorrect route status at these adjacent nodes may result.
- The real point code of the adjacent node is treated as a non-adjacent node. Therefore, network management messages expected only from adjacent nodes are rejected.
- Any traffic generated by an adjacent node for other nodes that have prohibited status at the EAGLE 5 are discarded at the EAGLE 5 and a TFP message is sent back to adjacent node. Adjacent nodes may ignore TFP messages from the EAGLE 5.
- The change-over and change-back for link failures are time controlled because the destination point code of the Changeover Order (COO) and Changeback Declaration (CBD) messages is the dummy point code, causing these messages to be ignored by the adjacent node. Also, the COO and CBD messages received by the EAGLE 5 from the adjacent node (configured as the dummy point code) are ignored by the EAGLE 5.

2.53 Allowed Affected Destination Field Screen (Release 22.0)

Release 22.0 introduces a new gateway screening entity, the **Allowed Affected Destination Field**. The **Allowed Affected Destination Field** contains the affected destination point code of incoming **MTP** network management messages. This is also referred to as the concerned point code.

The current method of screening the affected point code in network management messages involves a check for the point code in the routing table, self point codes, and capability point codes. This check is applied after the message has passed all screenings in the configured screen set. This check is independent of the screen set. In order to provide the same capability as currently exists, this method of screening for the affected point code in network management messages is retained. The network management message can also be screened with gateway screening screensets. To screen the network management message with the existing capability, the `destfld` parameter with either the `ent-scrset` or `chg-scrset` command (a new parameter introduced in Release 22.0) must be set to `yes`.

If the `destfld=yes` parameter is specified, all **MSU's** with the service indicator of 0 (`:si=0`), including through switched messages, are screened by gateway screening against the routing table, self point codes, and capability point codes. This screening step is performed after the **MSU** has passed all other screening tables.

The advantage of using the configured **Allowed Affected Destination Field** screening table over the routing table is that it is now possible to reject messages containing point codes in the routing table. Previously, if a network management message concerned a point code in the routing table, it would pass this phase of screening and there was no way to prevent its entry into the network. An interconnecting network could then either accidentally or maliciously send a network management message for a destination in the home network.

The network management messages that require screening by the **Allowed Affected Destination Field** screen are:

- **TFP, TFA, TFR**
- **TCP, TCA, TCR**
- **TFC**
- **UPU**
- **SRST (RSP, RSR)**

All other network management messages are passed.

For cluster messages (**TCP, TCA, and TCR**), the member of the affected destination field is set to 0. If the affected cluster contains a point code with a member 0, the affected destination field for a **TFx** message for the member and a **TCx** message for the cluster will have the same affected destination. For example, a **TFP** concerning point code 007-007-000 and a **TCP** concerning cluster point code 007-007-* will both have an affected destination of 007-007-000. Typically, a user would provision an entry in the allowed affected destination field with these parameters, `:ni=007, :nc=007, :ncm=*`, all **TFx** messages concerning the member of the cluster and all **TCx** messages concerning the cluster are passed. If the user

wants to screen **TFx** messages and **TCx** messages separately, the allowed **SIO** screen can be used to send **TCx** messages to one affected destination table, and send **TFx** messages to a different affected destination table.

The allowed affected destination field screen is configured with these commands.

- `ent-scr-destfld` - adding a new allowed affected destination field entry into the database
- `dlt-scr-destfld` - removing an allowed affected destination field entry from the database
- `chg-scr-destfld` - changing an existing allowed affected destination field entry in the database
- `rtrv-scr-destfld` - displaying the allowed affected destination field entries in the database

All these commands use these parameters.

- `sr` for the screening reference name of the allowed affected destination field screen
- `ni, nc, ncm` for **ANSI** point codes
- `zone, area, id` for **ITU** international point codes
- `npc` for **ITU** national point codes

The `chg-scr-destfld` command also uses these parameters for the point code values being changed.

- `nni, nnc, nncm` for new **ANSI** point code values
- `nzone, narea, nid` for new **ITU** international point code values
- `nnpc` for new **ITU** national point code values

The `rtrv-scr-destfld` command also uses the `all=yes` parameter to display a detailed output of the allowed affected destination field screen. The following is an example of the output of the `rtrv-scr-destfld:all=yes` command.

Output Example:

```

RLGHNCXA03W 97-06-07 13:14:18 EDT Rel 22.0.0
SCREEN = ALLOWED DESTFLD
SR  NI      NC      NCM      NSF1  NSR/ACT
IEC  240     001     010     STOP  -, -
IEC  241     010     *       STOP  -, -
SR  ZONE    AREA    ID       NSF1  NSR/ACT
IEC  1       003     4       STOP  -, -
IEC  1       003     5       STOP  -, -
SR  NPC
IEC  00235
IEC  00240
                                NSF1  NSR/ACT
                                STOP  -, -
                                STOP  -, -
  
```

The allowed affected destination field screen can be referenced, the next screening function indicator (**NSFI**), by the allowed **SIO**, allowed **DPC**, and blocked **DPC** screens. If the allowed affected destination field screen is the **NSFI** of the allowed **SIO** screen, the service indicator of the allowed **SIO** entry must be 0, specified by the `:si=0` parameter with the `ent-scr-`

`sio` and `chg-scr-sio` commands, and the entry 0 in the **SI** field in the `rtrv-scr-sio` command output.

The **NSFI** for the allowed affected destination field screen has only one value, **STOP**.

The redirect and copy functions, for the **STP LAN** and **DTA** features, (`:redirect=yes` and `:copy=yes` parameters with the `ent-scr-destfld`, `chg-scr-destfld`, and `rtrv-scr-destfld` commands) can be used with the allowed affected destination field screen.

2.54 Allowed CDPA Screen on SCCP Management Format ID (Release 22.0)

The allowed called party address (**CDPA**) screen can screen messages for the **SCMG** format **ID** (**SCCP Management Format ID**). A new parameter, `scmgid`, has been added to the `ent-scr-cdpa`, `dlt-scr-cdpa`, and `chg-scr-cdpa` commands to configure the allowed **CDPA** screen to screen for the **SCMG** format **ID**. A new field, **SCMGID**, has been added to the output of the `rtrv-scr-cdpa` command to show the **SCMG** format **ID** in the allowed **CDPA** screen. The following is an example of the new output.

Output Example:

```

RLGHNCXA03W 97-06-07 15:41:38 EDT Rel 22.0.0
SCREEN = ALLOWED CDPA
SR   NI      NC      NCM      SSN      SCMGID   NSFI     NSR/ACT
IEC  240     001     010     001     002     STOP    -, -
IEC  240     001     011     002     ----- STOP    -, -
IEC  240     001     010     12      ----- STOP    -, -
IEC  241     010     *       *       *       ----- AFTPC   IAFT

```

The value for the `scmgid` parameter is 1 - 255 or *. This parameter must be specified if the subsystem number of the called party address is set to 1 (`ssn=1`). An **SCCP** management message has the subsystem field of the called party address set to 1. The **SCCP** management format **ID** only applies to **SCCP** management messages.

The message type of the message being screened for the **SCCP** message format **ID** must be either a **UDT**, **UDTS**, **XUDT** or **XUDTS** message. All other message types are passed.

The wildcard value for the subsystem parameter (`ssn=*`) indicates the range of values from 2 to 255. When the subsystem number is a wildcard, the next screening function identifier must be `stop` (`nsfi=stop`). The **SCMG** format **ID** does not apply because messages with a subsystem of 2 to 255 are not **SCCP** management messages.

If the value of the `ssn` parameter is not a wildcard (1 - 255), the **NSFI** for the Allowed **CDPA** screen can be either the allowed affected point code screen (`aftpc`) or `stop`.

2.55 Alternate Command Keywords (Release 20.0)

This feature provides an alternate set of keywords for current **EAGLE** commands. The following are the new, industry-standard keywords:

Table 2-10 Alternate Set of Command Keywords

EAGLE Keyword	Alternate Keyword
cancel	deactivate
inhibit card	remove card
allow card	restore card
act lpo	block slk
allow slk	uninhibit slk
cancel lpo	unblock slk

2.56 ANSI G-Flex Support at 1700 TPS per DSM (Release 30.3)

The feature **ANSI G-Flex Support at 1700 tps per DSM Card** increases the current transaction-per-second (tps) capacity of the **G-Flex** application running on **DSMs** cards from 850 tps to 1700 tps in an **ANSI** environment.

- In an **ITU** environment, the capacity will remain at 850 tps per **DSM** card
- The Service Selector table cannot contain an **ITU** entry Only **G-Flex** is defined as a service (see the -srvsel commands)
- The **G-Flex** feature is turned on
- The ansigflex system option is enabled using the chg-stpopts command.

2.57 ANSI support for RANDOM SLS on Incoming Linkset (Release 40.0)

The ANSI support for RANDOM SLS on Incoming Linkset (ANSI Random SLS) feature allows the Random **SLS** (Signaling Link Selector) feature to support ANSI Class0 and ISUP traffic on the incoming linkset. If the Replace system option is provisioned, then the SLS value in the message is replaced with a randomized SLS value. This value is used for linkset and link selection during message routing instead of the SLS on an incoming ANSI MSU.

2.57.1 Feature Control Requirements

The ANSI Random SLS feature has the following feature control requirements:

- The `chg-stpopts:randsls=perls` command must be entered before ANSI RANDSLs processing can occur.

Note:

ANSI RANDSLs processing occurs only on incoming linksets where the linkset **randsls** parameter is set to a value other than **off**.

- The `chg-ss7opts:slsreplace=yes` command must be entered before the SLS in the message can be replaced with a random SLS value.

2.58 ANSI-41 AnalyzedInformation Query - no EPAP/ELAP (Release 42.0)

The ANSI-41 AnalyzedInformation Query (**ANSI41 AIQ**) feature allows customer migration from one technology to another (e.g. **CDMA** to **LTE**), on an individual subscriber basis. This feature addresses termination call handling by providing the ability to indicate which calls are destined for a particular technology.

The feature allows an AnalyzedInformation query to be responded to using an optional parameter that contains pre-configured response digits. These digits are configured to map to trigger type parameter values in the query. The Mobile Switching Center (**MSC**) that sent the AnalyzedInformation query interprets the response digits to route the call appropriately.

The trigger type in the AnalyzedInformation query is determined by prior interaction between the MSC and the Home Location Register (**HLR**) which contains the subscriber information,

The ANSI41 AIQ feature is implemented as a local AIQ **SCCP** subsystem on the EAGLE 5 ISS and does not require the EPAP or ELAP database. A new AIQOPTS table is used to provision ANSI41 AIQ options. This table is part of the existing EGLEOPTS table.

The **AIQ** subsystem supports SCCP **UDT** and non-segmented **XUDT** Class 0 or Class 1 messages and ITU MTP/SCCP, ANSI MTP/SCCP, and ANSI TCAP messages. The subsystem does not support segmented SCCP or TCAP messages.

The ANSI41 AIQ feature does not support the ITU-N24 point code type.

2.58.1 Feature Control Requirements

- FAK for part number 893-0349-01
- The GTT feature bit must be turned on before the ANSI41 AIQ feature can be enabled.
- The ANSI41 AIQ feature cannot be enabled with a temporary FAK.
- The ANSI41 AIQ feature can be turned on and off.

2.58.2 Hardware Requirements

The ANSI41 AIQ feature requires **Service Module cards**.

2.59 ANSI-41 INP Query (AINPQ) (Release 36.0)

Description

The ANSI-41 INP Query (AINPQ) feature adds support for using an ITU-N **ANSI-41 NPREQ** message for querying the **INP** database, in addition to the existing **INP** feature number portability query using the **ITU-N** and **ITU-N24 INAP IDP** message.

A feature access key (**FAK**) for part number 893017801 is required to enable the **AINPQ** feature.

- The **GTT** feature must be on before the **AINPQ** feature can be enabled.
- After the feature is enabled and turned on, it cannot be turned off.
- No temporary **FAK** is allowed for the feature.
- If any **LNP** quantity feature is enabled, the **INP** and **AINPQ** features cannot be enabled. If either the **INP** feature or the **AINPQ** feature is enabled, no **LNP** quantity feature can be enabled.
- The **AINPQ** feature and the **EIR** feature cannot be enabled in the system at the same time.

The **AINPQ** feature supports a mix of **ITU** and **ANSI** protocols in querying the **INP** database using the **ANSI-41 NPREQ** query.

Service selectors, **INP** options, and measurements are common to the **INP** and **AINPQ** features.

INP message relay functions operate when the **INP** feature, the **AINPQ** feature, or both features are turned on. The parameter values defined for **INP** query processing (through the **INPQ** service or **PC/SSN**) can apply to both the **INP** and **AINPQ** feature if both features are turned on.

INP query processing can be invoked by the following mechanisms (**MTP** routed **NPREQ** is not supported):

- For **GTT**-routed **NPREQ** query, **INP** query processing can be invoked using the **inpq** service selector that is defined using the **SCCP Service Selector** commands.
- For **NPREQ**-routed-based **PC/SSN** query, **INP** query processing can be invoked using the **EAGLE 5 ISS** point code and local subsystem number (**PC/SSN**) defined for the **INP** feature.

When the **AINPQ** feature is turned on, the **INP** query processing operates as follows:

- Handling of an **ITU-N Point Code ANSI-41 NPREQ** query encoded in **ANSI-41 TCAP**, **ITU SCCP**, and **ITU MTP** protocol stack is supported.
- **ITU MTP/SCCP** protocol validation and **ANSI TCAP** protocol validation for a received **ANSI-41 NPREQ** query are supported.
- For a received **ANSI-41 NPREQ** query subject to the **INP** query processing, the **EAGLE 5 ISS** uses the digits encoded in the **DGTSDIAL** parameter for database lookup.
- The **EAGLE 5 ISS** performs number conditioning on the **DGTSDIAL** value in preparation for database lookup. The Called Party Prefix, National Escape Code, Service Nature of Address, Nature of Number, and Country Codes are used to condition the number as a National or International number.
- Enhanced **AINPQ** and **INP** options for the Global Option for Connect on **INP** Query feature can be used to format information in the response that results from the database lookup.
- The **AINPQ** feature and the **INP** feature share the **INP** local subsystem, including **SCCP** subsystem management and service selection.
- The **AINPQ** feature and the **INP** feature share the **CPCTYPE (Capability Point Code Type)** state.

When the **INP** feature is turned on, the **INP** query processing operates as follows:

- Handling of the **ITU-N** and **ITU-N24 INAP IDP** message is supported.
- **CDPN** number conditioning is performed in preparation for database lookup.

- Enhanced **AINPQ** and **INP** options for the Global Option for Connect on **INP** Query feature can be used to format information in the response that results from the database lookup.

The **INP** options in the **EAGLE 5 ISS** have been enhanced to support the **AINPQ** feature.

- A new **INP** option is provided to define the National Escape Code (**NEC**) value, up to 5 digits, for each **EAGLE 5 ISS** node.
- The maximum number of Called Party Prefix entries allowed in the **INPOPTS** table has been increased from 5 to 40.
- **AINPQ** supports the Global Option for Connect on **INP** Query Response feature that was previously implemented for **INP**. The destination routing address (**DRA**) options have been enhanced for **INP** and **AINPQ** for formatting the **ROUTDGTS** parameter in the **INP** “Connect” message or **AINPQ NPREQ** “Return Result” response message, as follows:
 - Support **RN + [CDPNPFX] + DN** in **INP** “Connect” or **AINPQ** “Return Result” response messages
 - Support Routing Number in in **INP** “Connect” or **AINPQ** “Return Result” response messages
 - Support **[CDPNPFX] + CC + RN + DN** in **INP** “Connect” or **AINPQ** “Return Result” response messages
 - Support **RN + [CDPNPFX] + NEC + DN** in **INP** “Connect” or **AINPQ** “Return Result” response messages (the National Escape Code must be provisioned)

There are no new measurements pegs for **NPREQ** queries. The existing **INP** registers are pegged for the **NPREQ** query, the **IDP** query, or both; the peg for “**IDP** received” is a total count of the number of the **IDP** and **NPREQ** queries received if both the **AINPQ** and **INP** features are turned on.

Hardware Requirements

The **ANSI-41 INP** Query feature has the following hardware requirements:

- **DSM** card with at least 4G of memory running the **VSCCP** application
- After **AINPQ** is enabled, no **DSM** cards with less than 4G of memory can be provisioned. **DSM** cards installed with less than 4G of memory will be auto-inhibited if **AINPQ** is enabled.

Assumptions

The **ANSI-41 INP** Query feature assumes that an **MSC** will not initiate an **NPREQ** query for a call prefixed with International Escape Code (commonly defined as “00”) + **CC+DN**, as the call is intended for terminating to an international subscriber.

Limitations

None

2.60 ANSI-41 Mobile Number Portability (A-Port™) (Release 36.0)

Description

The ANSI-41 Mobile Number Portability (A-Port) feature enables an **IS41** subscriber to change to a different service provider while retaining the same Mobile Dialed Number (**MDN**).

A-Port uses the **EPAP** (**EAGLE** Provisioning Application Processor) **RTDB** provisioning database to retrieve the subscriber portability status and provision directory numbers for exported and imported **IS41** subscribers. This database maintains information related to subscriber portability in the international E.164 format. **A-Port** uses **RN** and **PT** values to provision directory numbers (**DNs**) for exported subscribers. In addition, **A-Port** uses **SP** to provision **DNs** for imported subscribers. It is optional to provision the **PT** values for imported subscribers.

Service Selector Lookup

Service selector lookup is performed using the **MTP/SCCP** data. If the selectors match and **MNP** service is assigned, **A-Port** handling is performed.

To manage number portability, **A-Port** uses the **MNP SCCP Service Selector** to process **LOCREQ** and **SMSREQ SCCP** messages. The **EAGLE ISS** intercepts **LOCREQ** messages for the **RTDB** database lookup. An **ANSI-41 LOCREQ** message is initiated by a **TDMA/CDMA MSC** that queries the **HLR** for information regarding user subscription/location before terminating a voice call.

A-Port supports both **GT-** and **MTP-**routed messages.

- **GT-**routed messages support **UDT** and non-segmented **XUDT** message types and perform service selector lookup after **SCCP** verification.
- **A-Port** processes **MTP-**routed messages if the **MTP Messages for SCCP Applications (MTP Msgs for SCCP Apps)** feature is turned on (see [IS41 GSM Migration \(Release 36.0\)](#) for details of **MTP-**routed message processing).

MNP begins **A-Port** general **TCAP/MAP** verification if the message is **ANSI TCAP** and **A-Port** is turned on. **TCAP/MAP** verification is performed on all messages; **A-Port** supports only the **ANSI TCAP** format.

Database Lookup and Routing

The **DN** is used for database lookup.

- For **LOCREQ** messages, the **DN** is derived based on the setting of the **LOCREQDN** option (see the new `chg-is41opts` command).
- For non-**LOCREQ** messages, the **DN** is derived from the **SCCP** portion of the message.
- **A-Port** performs number conditioning upon successful decode and verification of the message. HomeRN and **IEC** or **NEC** prefixes are removed. The **DN** is conditioned to international number format based on the service nature of address (**SNAI** or **TCAPSNAI** or **MTPLOCREQNAI**).

A-Port performs **RTDB** lookup on the conditioned number, and routes or relays the message based on the lookup result.

- An **SMSREQ** message is relayed like any other non-**LOCREQ** message. No changes are performed to the **TCAP/MAP** portion of the message.
- **A-Port** modifies the **TCAP** information for **LOCREQ** messages only when a HomeRN was deleted from the **TCAP DN** and **LOCREQRMHRN = YES**. Any gaps in the data caused by a change in field length will be resolved by shifting the remaining information up. Any **IEC** or **NEC** code is left.
- **A-Port** falls through to **GTT** if number conditioning fails or does not find the **DN** in the **RTDB** database, or the **DN** is found with non-**A-Port** data.
- If a HomeRN is detected in the Called Party and a matching **DN** with **RN** is found in the database, the **EAGLE 5 ISS** generates **UIM 1256**, indicating detection of circular routing, and routes the message using normal routing if both the **MNP Circular Route Prevention** feature and the **IS41 GSM Migration** feature are turned on.
- Normal routing is performing **GTT** if the incoming message is sent to the **EAGLE 5 ISS Self Point Code**. Normal routing is routing the message to the **MTP DPC** if the incoming message is **MTP**-routed (the **MTP DPC** of the message is not the **EAGLE 5 ISS Self Point Code**).

A-Port shares the service state and re-route with the **IS41 GSM Migration** feature and the **G-Port** feature, under one service called the **MNP** service state. (The **G-Port** service state is used if only the **G-Port** feature is on.) **A-Port** supports re-route functions as part of **MNP** service re-route. Alternate **PCs** are shared by all three features.

Alarms and the `rept-stat-sccp` command output show **MNP** Service information if the **A-Port** feature is enabled.

Feature Access Key

A feature access key (**FAK**) for part number 893015501 is required to enable the **A-Port** feature.

- The **GTT** feature must be on before the **A-Port** feature can be enabled.
- After the feature is enabled and turned on, it cannot be turned off.
- No temporary **FAK** is allowed for the feature.
- An **LNP** quantity feature and the **A-Port** feature cannot be enabled in the system at the same time.

Measurements

The following enhancements support the collection and retrieval of measurements related to the **A-Port** feature. These new measurement registers are supported with and without the Measurements Platform feature enabled.

- New registers are added to the **NP SSP** reports: Hourly Maintenance Measurements on **NP SSP (MTCH-SSP)** and Daily Maintenance Measurements on **NP SSP (MTCD-SSP)**.
 - **APLRACK**—Number of call related **LOCREQ** messages acknowledged.
 - **APLRRLY**—Number of call related **LOCREQ** messages relayed.
 - **APNOCL**—Number of non-call non-**LOCREQ** related messages relayed.
 - **APNOCLGT**—Number of non-call Non-**LOCREQ** related messages that fell through to **GTT**.

Feature Interactions

G-Port, A-Port, and IS41 GSM Migration solve the problem of number portability from one network to another or number migration from one mobile protocol to another. One, two, or all three features could be active on a single **EAGLE 5 ISS** node at a given point. Because all of these features could have same type of **MTP** and **SCCP** layers (**ITU** or **ANSI**), it may look like same kind of message at service selection, which looks at the network domain and **SCCP** parameters. Therefore, all three features share one service. Because of this, existing functions like **SRVSEL**, Service, Re-route, **CPC** and **rept-stat-sccp** command service snapshot counts are affected.

Hardware Requirements

The **A-Port** feature has the following hardware requirements:

- **DSM** cards with at least 4G of memory
- **A-Port** cannot be enabled if any **DSM** cards with less than 4G of memory or any **TSM** cards for **SCCP** are present in the system. When **A-Port** is enabled, no **DSM** cards with less than 4G of memory and no **TSM** cards for **SCCP** can be provisioned for **SCCP**.

Assumptions

Within a portability domain (ordinarily a country) a Mobile Directory Number (**MDN**) assigned to an **IS41** subscriber will not overlap with an **MSISDN** assigned to a **GSM** subscriber (one dialed **DN** can either be an **IS41** or a **GSM** subscriber). Therefore, **IS41** and **GSM** subscriber data can co-exist in the same **EPAP** provisioning database.

Limitations

The **A-Port** feature has the following limitations:

- Communication between the **SMSCs** in the originating network (a calling party's home network or the network where the call was originated) and the **SMSC** in the terminating network is through **SS7** and not **SMPP**.
- Number Portability across multiple countries is not supported.

2.61 ANSI-ITU-China SCCP Conversion (Release 31.3)

Since some **ANSI** and **ITU SCCP** parameters are incompatible in format and/or coding, subsequently the **EAGLE** has not historically supported **SCCP** traffic between **ANSI** and **ITU** networks. A specialized **SCCP/TCAP** conversion was previously implemented for **MTP Routed UDT/UDTS** messages. This feature will not interact with the Release 22.2 **SCCP/TCAP** conversion feature but will be mutually exclusive of it. Since the specialized **SCCP/TCAP** conversion was implemented, many improvements have been made to the **EAGLE** in regards to **ITU SCCP** compliance and features. (e.g. **EGTT**, **MGTT**). **ANSI-ITU-China SCCP Conversion** will provide a generic capability that will correctly format and decode/encode the following inter-network **SCCP** traffic:

- **UDT** and **UDTS** messages - includes **SCMG** messages, which are a specialized form of a **UDT**
- **MTP** routed
- **GT** routed

The feature also provides **SCCP** management (**SCMG**) across network type boundaries, i.e. concerned point codes for a mated application may be of a different network type than the mated application.

UDTS message return is controlled inherently by the **SCCP** layer protocol within the protocol class byte. If bits 5-8 indicate return message on error, a **UDTS** message will be sent when there is an error. Otherwise, no **UDTS** is returned to the originator.

2.62 ANSI/ITU MTP Gateway (Release 20.0)

The **EAGLE** acts as a gateway to connect **ANSI**, **ITU** international, and **ITU** national networks. The **EAGLE** also continues to switch traffic that does not need to be converted when the origination network is the same network type as the destination network. In order to be able to perform these functions, the **EAGLE** does the following.

- Discriminates between **MSUs** originating from each type of network
- Converts **MSUs** to the appropriate format by converting the message transfer part (**MTP**) and **ISDN** user part
- Routes **MSUs** to the correct destinations

Level 3 MSU Discrimination

The **EAGLE** must determine whether an incoming **MSU** terminates at the **STP** or must be routed to another destination. To accomplish the discrimination task, the **EAGLE** does the following.

- Compares the network indicator (**NI**) of an **MSU** to a database of valid **NIs**. If the network indicator is not valid, the **MSU** is discarded.
- Extracts the network indicator and destination point code (**DPC**) information from the incoming **MSU**. If an **MSU** is transmitted to an **ANSI** linkset, the network indicator is forced to a binary pattern of “10” before being extracted.
- Determines whether an incoming **MSU** terminates at the **EAGLE** or must be routed to another destination by joining the network indicator and **DPC** to a list of self point codes. The self point code is a combination of the true point code and capability point code. The capability point code identifies a group of nodes that have similar capabilities.

MSU Routing

MSU routing occurs after **MSU** discrimination and before **MSU** conversion (if conversion is necessary). The **EAGLE** selects an outgoing link on which to transmit the **MSU**. The **MSU** formats must be compatible with the linksets that transmit the **MSUs**.

EAGLEs are typically deployed in mated pairs. The **EAGLE** has a linkset for each supported network type. The **EAGLE** should have a unique adjacent point code. The **EAGLE** supports up to three self point codes—one for **ANSI** point codes, one for **ITU** international point codes, and one for **ITU** national point codes.

Figure 2-5 shows a sample network with mated gateway **STPs**. Note that there are different linksets for each network type. In the sample, **STP** (A) has an **ANSI** point code (007-001-001), an **ITU** National point code (09270), and an International point code (5-060-1).

Figure 2-6 Sample Gateway STP Network

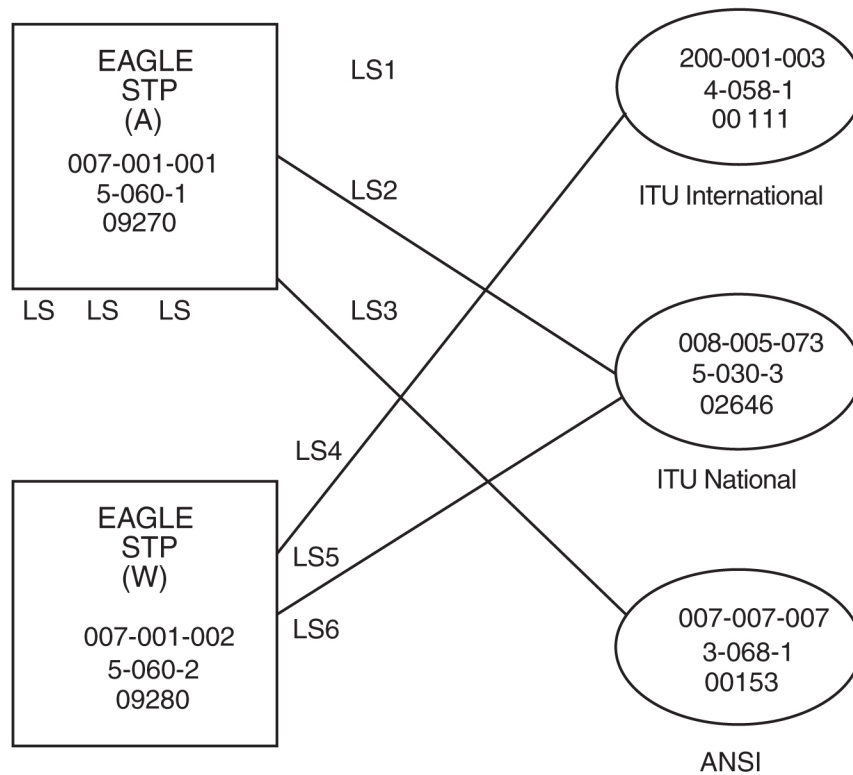

Administering Point Codes

The **EAGLE** can support multiple network types because each destination can be addressed by a true point code or by a list of alternate point codes. The list of alternate point codes contains from 0 to 2 alternates. The true point codes and alternate point codes are entered in the key table (by using the `ent-dstn` command). For example, an **ANSI** destination could have both a true point code and an alternate point code that point to the same routing translation in the routing table.

Local Link Congestion

When a link is congested, the **EAGLE** sends **ANSI TFCs** to the **ANSI** origination point code (**OPC**) and **ITU TFCs** to the **ITU** origination point code (**OPC**). **Figure 2-6** shows both an **ANSI** and an **ITU** network sending traffic to a congested link (the type of congested link does not matter). When an **ANSI** node is the source of the traffic to the congested link, the **TFC** contains a status. When an **ITU** node is the source of the traffic, the **TFC** does not contain a status.

Figure 2-7 Traffic to and from a Congested Link

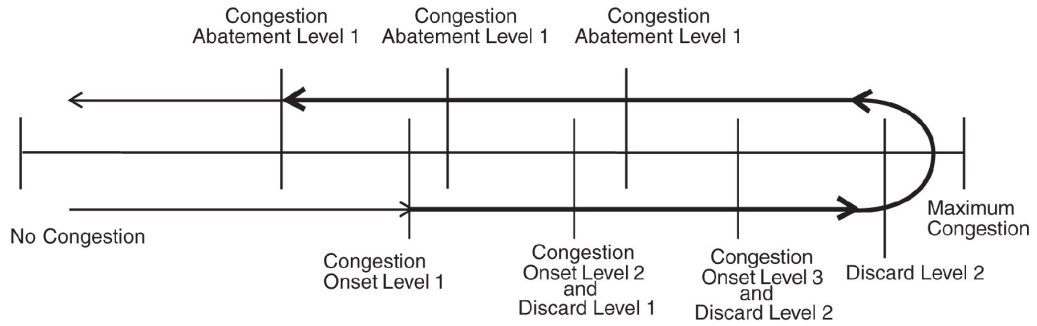

All links in the system operate with four levels of congestion. If the congestion level is "0", there is no congestion, the **EAGLE** does not transmit **TFCs**, and no **MSUs** are discarded. At level 3 (indicating a maximum level of congestion), the **EAGLE** transmits **TFCs**, and discards **MSUs**.

Whenever the congestion onset status is above congestion onset level 1, and has not abated below congestion abatement level 1, the **EAGLE** generates a **TFC**. Whenever the congestion discard status is above discard level 1, and has not abated below discard level 1, the **EAGLE** discards the **MSU**. See [Figure 2-7](#).

Figure 2-8 Congestion Levels

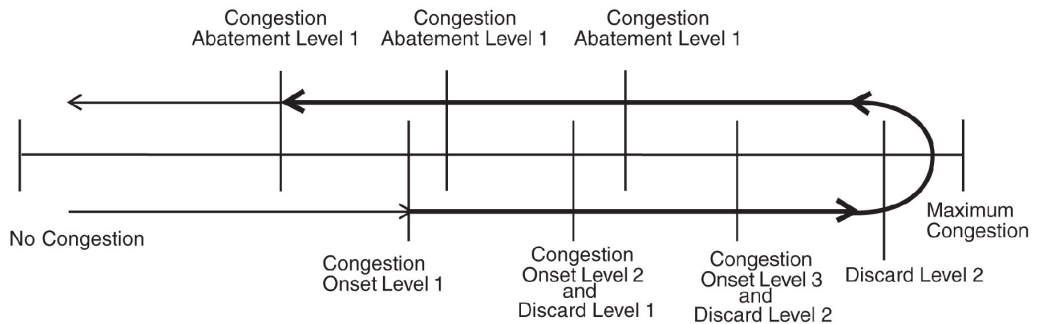

Remote Link Congestion

[Table 2-4](#) shows the **EAGLE**'s response to remote congestion indicators.

Table 2-11 Remote Congestion Response

Event	EAGLE's Response
EAGLE receives an ANSI TFC	When the EAGLE receives an ANSI TFC , the routing table is modified to discard lower priority MSUs being routed to the concerned point code. The TFC contains the congestion status of the concerned point code. The routeset congestion test mechanism is used to abate the congestion.

Table 2-11 (Cont.) Remote Congestion Response

Event	EAGLE's Response
EAGLE receives an ITU TFC	When the EAGLE receives an ITU TFC , the routing table is modified to discard the lower priority MSUs being routed to the concerned point code. The TFC does not contain the congestion status of the concerned point code. Instead, the congestion status is user-configurable using the <code>chg-isup-stp:status</code> command. Once the routeset is identified as congested, a timer is used to abate the congestion. The timer is similar to the ANSI routeset congestion test mechanism.
EAGLE receives an ANSI RCT	There is no change in the EAGLE response when the EAGLE receives ANSI routeset congestion test messages.
EAGLE receives an ITU RCT	The H0H1 message codes are not contained in the ITU environment. These codes generate an invalid H0H1 MRN , and the message is discarded. This has no impact on the ITU network because the EAGLE uses a timer to abate congestion and does not rely on a reply to the RCT message.

2.63 ANSI/ITU SCCP and TCAP Conversion (Optional) (Release 22.2)

As an option for release 22.2, the **ANSI/ITU SCCP** and **TCAP** Conversion feature enables the **EAGLE STP** to convert **MTP**-routed **SCCP** and **TCAP** messages from **ANSI** to **ITU** format and to convert **ITU** formatted messages to **ANSI**. The following formatting and coding is supported:

- **MTP** routed Unitdata (**UDT**) non-segmented **SCCP** connectionless messages, including **SCMG** messages.
- **MTP** routed Unitdata Service (**UDTS**) messages (**UDT** messages returned due to error).

SCCP and **TCAP** conversion is turned on by way of two separate feature bits, one for the **SCCP** conversion and one for the **TCAP** conversion. The **SCCP** conversion feature must be turned on before, or at the same time as, the **TCAP** conversion feature.

2.64 ANSI/ITU SCCP and TCAP Conversion (Release 24.0)

As an option for release 24.0, the **ANSI/ITU SCCP** and **TCAP** Conversion feature enables the **EAGLE STP** to convert **MTP**-routed **SCCP** and **TCAP** messages from **ANSI** to **ITU** format and to convert **ITU** formatted messages to **ANSI**.

Note:

This feature is a customized feature and does not conform to any known standard or specification.

The following formatting and coding is supported:

- **MTP** routed Unitdata (**UDT**) non-segmented **SCCP** connectionless messages, including **SCMG** messages.
- **MTP** routed Unitdata Service (**UDTS**) messages (**UDT** messages returned due to error).

SCCP and **TCAP** conversion is turned on by way of two separate feature bits, one for the **SCCP** conversion and one for the **TCAP** conversion. The **SCCP** conversion feature must be turned on before, or at the same time as, the **TCAP** conversion feature.

2.65 ANSI/ITU SCCP Conversion – Optional Conversion of CgPA when Crossing ITU-x Domains (Release 45.0)

The SCCPOPTS:CNVCLGITU parameter makes the SCCP CgPA conversion optional for messages crossing ITU-x->ITU-y domain. The default value of this parameter is off when the ANSI/ITU SCCP Conversion feature is turned on. In case of ITU-x->ITU-y domain crossing, SCCP conversion will not be performed on CgPA. x and y are different variants of ITU networks: International, National, International Spare, and National Spare. ITU-x->ITU-y SCCP CgPA conversion is optional for GTT, GTT Actions, GTMOD, and MAP SCRNs. This does not apply to services and subsystem that perform GTT on CgPA, such as G-Port, EIR, and IDPR.

2.66 ANSI/ITU Translation (Release 35.0)

Description

The ANSI/ITU Translation feature allows any domain GTT selector to be assigned to a 'cross' domain GTT set. This allows access to GTA data within a GTT set that can be used to translate ANSI and ITU messages.

ANSI/ITU translation allows a user to provision a single cross domain GTT set with one set of GTA data and assign it to multiple GTT selectors, regardless of their domain. Since the user does not have to provision a GTT set with the same GTA data for each network domain GTT selector (gtia=2, gtii=2, gtii=4), GTA table space and user-provisioning activity is conserved.

The Enhanced GTT feature and ANSI-ITU-China SCCP Conversion feature must be on before the ANSI/ITU Translation feature can be enabled.

Hardware Requirements

The ANSI/ITU Translation feature has the following hardware requirements:

- Use of TSM or higher SCCP cards.
- LIM hardware types.

Limitations

The ANSI/ITU Translation feature has no associated limitations.

2.67 A-Port Circular Route Prevention (Release 41.1)

The existing MNP Circular Route Prevention feature is enhanced to provide the same functions for A-Port and IS41 messages as it currently provides for G-Port and GSM messages. A-Port Circular Route Prevention (A-Port CRP) detects and prevents circular routing for all messages that receive A-Port service, including LOCREQ and SMSREQ messages. The functions help to detect circular routing that is caused by incorrect information in number portability databases in one or more networks.

On receipt of a valid IS41 message by the MNP service, the EAGLE 5 ISS determines whether a circular route is present based on the presence of a HomeRN in the called party number of the message and on the portability information in the database.

- If this called party number is a ported-out number (foreign subscriber), UIM 1256 “NP Circular Route detected” is generated and, depending on the GTT provisioning, either a UDS is sent using SCCP information or the message is routed to a GT translated point code.
- If the number is a ported-in number (own network subscriber), the EAGLE 5 ISS relays the message directly to the **HLR** using the RTDB result information.

2.67.1 Feature Control Requirements

The **GTT**, A-Port, and MNP Circular Route prevention features must be enabled and turned on before circular route prevention can be performed for the A-Port feature.

2.67.2 Hardware Requirements

The A-Port feature requires Service Module cards (4G or higher DSM cards, E5-SM4G cards, or a mixture of both).

2.67.3 Limitations

Circular route conditions occur only for Other Licensed Operator (**OLO**) subscribers and not for migrated customers (who are still in their own network). Therefore, running the MNP Circular Route Prevention feature when only the IS41 GSM Migration (IGM) feature is on (A-Port or G-Port is not on) is not valid. Support for Circular Route Prevention when only the **IGM** feature is ON is already supported and will continue to exist only for ITU MAP messages.

2.68 ASM Obsolescence (Release 31.6)

The current Application Services Module (**ASM**) card is an aging board with limited functionality when compared with today's modern day processors. This feature removes **ASM** card support in **EAGLE** software. The **ASM** card currently supports only two application Generic Program Loads (**GPLs**), the **Signaling Connection Control Part (SCCP)** and Gateway Loading Services (**GLS**) applications. The **TSM** card already supports both of these applications. Supported **GPLs** by card type are shown in [Table FN-1](#).

Table 2-12 GPL Support for ASM and TSM Cards

GPL	ASM Card	TSM Card
Before ASM Obsolescence		
GLS Application supported	Yes	Yes
SCCP Application supported	Yes	Yes
After ASM Obsolescence		
GLS Application supported	No	Yes
SCCP Application supported	No	Yes

Hardware Required

Any **ASM** cards in the system must be replaced with **TSM** cards before the Release 31.6 upgrade can occur.

 **Note:**
 Release 31.X baseline hardware includes **GPSMIIs**, **HMUXs**, -10s **TDMs**. If these modules are not equipped the act-upgrade command will be rejected.

Limitations

- Beginning with **EAGLE** software release 31.6, there will be no support for the **ASM** card and card type.

2.69 ATINP Service Portability (Release 41.1)

Service Portability support for the ATINP feature indicates whether Service Portability applies to ATI ACK messages for own-network subscribers. When Service Portability is applicable, and the **atiackrn=rn** parameter is provisioned, GRN digits are used to encode RN digits in the response message..

As part of the support for Service Portability, ATINP no longer considers the incoming MSISDN numbering plan; the numbering plan in the MSISDN in the ATI ACK message will be the same as the incoming MSISDN numbering plan.

2.70 ATI Number Portability Query (ATINP) (Release 39.2)

The ATINP feature is used to obtain number portability and routing information for a subscriber directly from the EAGLE 5 ISS number portability database. The feature allows a node to send a GSM MAP_Any_Time_Interrogation (**ATI**) query directly to the EAGLE 5 ISS (which supports the ATINPQ local subsystem) to obtain number portability and routing information for a mobile subscriber from the number portability database. This information is encoded in the ATI response message.

The ATINP feature supports RT-on-SSN and RT-on-GT messages to the EAGLE 5 ISS TSPC/ATINP CPC if the message criteria matches the SSN and service selectors, respectively, for ATINP. If an SCCP message arrives and matches the ATINP service selectors, then it is automatically forwarded to the ATINPQ local subsystem.

The ATINP feature supports ASD digits that are returned from the database lookup for an individual directory number (**DN**) or a range of DNs. If ASD digits are found in the lookup, then the digits are used to format the routing number, MSISDN, and IMSI entities in the outgoing response.

**Note:**

The ATINP feature must be turned on before full processing of an ATI message by the ATINPQ subsystem can be performed.

2.70.1 Feature Control Requirements

The ATINP feature has the following feature control requirements:

- FAK for part number 893-0221-01
- The GTT feature bit must be turned on before the ATINP feature can be enabled.
- The `defcc` parameter for the `chg-stpopts` command must have a value other than **none**.
- The ATINP feature can be turned on and off.
- A temporary FAK cannot be used to enable the feature.
- The ATINP feature cannot exist on the same node as the LNP features.

2.70.2 Hardware Requirements

The ATINP feature requires Service Module cards. The ATINP feature cannot be enabled if TSM cards running the **sccp** application are provisioned in the system. TSM cards running the **sccp** application cannot be provisioned if the ATINP feature is enabled.

2.70.3 Limitations

Due to the 150-character limit on command length, a single `ent/chg-atinpopts` command may not fit on a single line. Two commands may be required to complete the desired provisioning.

2.71 Auto Point Code Recovery (Releases 35.6, 37.5)

The Auto Point Code Recovery feature enhances the ability of the EAGLE 5 ISS to handle circular routing that is caused by far-end loopback. The feature also automatically resets a destination point code (**DPC**) that has been marked as prohibited due to circular route detection (**CRD**).

The EAGLE 5 ISS detects far-end loopback in a link through the signaling link test control (**SLTC**) procedure. The originating point code (**OPC**) sends a signaling link test message (**SLTM**) across a link to the **STP** and expects a signaling link test acknowledgement (**SLTA**) from the STP. If far-end loopback occurs in the connecting link, then the OPC receives the same SLTM instead of an SLTA. The OPC marks the link as failed as soon as it receives the SLTM.

The circular route caused by the loopback can cause multiple **MSUs** to be returned to the OPC, which can increase the congestion level on the link and invoke CRD processing. CRD marks the link as failed and marks the DPCs as CRD-prohibited. After a link has been marked, the link cannot be used until the DPC is cleared.

The Auto Point Code Recovery feature consists of two separate features. Each feature addresses an aspect of far-end loopback and CRD.

- **Enhanced Far-End Loopback Detection**
The Enhanced Far-End Loopback Detection feature significantly decreases the time required to take a link out of service by failing a link as quickly as possible when an SLTM is received. The rapid failure prevents the EAGLE 5 ISS from marking DPCs as CRD-prohibited.
- **Circular Route Auto-Recovery**
The Circular Route Auto-Recovery feature automatically clears CRD when far-end loopback is detected, and the failing link is part of the linkset that detected the circular route. If the Circular Route Auto-Recovery feature is not enabled, the user must clear CRD manually by executing the `rst-dstn` command.

2.71.1 Feature Control Requirements

The Auto Point Code Recovery feature has the following feature control requirements:

- Separate FAKs are required to enable the Circular Route Auto-recovery and Enhanced Far-End Loopback Detection features.
 - Circular Route Auto-Recovery feature: FAK for part number 893-0176-01
 - Enhanced Far-End Loopback Detection feature: FAK for part number 893-0181-01
- The Enhanced Far-End Loopback Detection and Circular Route Auto-Recovery features can be enabled separately.
- The Enhanced Far-End Loopback Detection and Circular Route Auto-Recovery features can be turned on and off.
- Temporary FAKs cannot be used to enable the Enhanced Far-End Loopback Detection or Circular Route Auto-Recovery features.
- **SLTMs** must be enabled (`chg-slt` command) before the Enhanced Far-End Loopback Detection or Circular Route Auto-Recovery feature can operate.

2.71.2 Hardware Requirements

There are no additional hardware requirements for this feature.

2.71.3 Limitations

When this feature is implemented, the capacity limits for combinations of DN/IMSI will be less than what is supported today.

- Existing limit: {DN, IMSI} = {36M, 60M}, {12M, 82M} and {6M, 90M}
- New limit for EPAP 10.0: {DN, IMSI} = {36M, 52M}, {12M, 75M} and {6M, 82M}

This decrease in capacity is based on high-level engineering design for the feature. Since these combinations are not used in the field, this limitation does not affect any customers.

2.72 Automatic PDB and RTDB Backup (EPAP 7.0)

Description

The Automatic PDB/RTDB Backup feature allows for the scheduling of automated backups of **EPAP** PDBs and RTDBs. The **PDB** backup copy is created on the EPAP A server and the **RTDB** backup copy is created on the standby EPAP server (A or B). A specific destination for the backup copy can be configured at the users discretion.

From the EPAP **GUI** terminal (Web **UI** only), the user can access a graphical user interface screen and configure the time, frequency, and destination of the backup copy.

Tekelec recommends that an Automatic PDB/RTDB Backup be performed on a daily (24 hour) basis. Both the PDB and RTDB backups are scheduled together and cannot be scheduled separately. The **Time of the day to Start The Backup** is the time that the RTDB backup starts. The PDB backup automatically starts 1 hour later.

Backups can only be scheduled and created on a provisionable EPAP server pair. An automatic PDB/RTDB backup is not allowed and cannot be scheduled on a non-provisionable EPAP server pair.

Normal provisioning is allowed during the automatic PDB/RTDB backup. This includes provisioning from

- the customer network to the PDB,
- the PDB to the Active EPAP RTDB, and
- the Active EPAP RTDB to the **DSM** RTDB.

RTDB backups are always created from the standby EPAP RTDB (A or B). The RTDB can resume receiving updates when it is brought back on line.

Disk Space Limitations

This feature supports the retention of three backup copies of the PDB and RTDB databases. However, the disk space in the EPAP free directory may not be sufficient to accommodate the retention of three backup copies on sites with large PDB and RTDB databases. When insufficient disk space exists, a dialog box appears asking the user “Do you want to delete the old backups”.

- If yes, the new database backup copy is written over the previous version.
- If no, the user must create a directory in a location with sufficient disk space and then specify the location of the backup directory to create the backup copy in.

Automatic PDB/RTDB Backup Screen

This feature adds to the list of EPAP Maintenance menu options, the item “Automatic PDB/RTDB Backup”. The scheduled time, frequency, and destination of the backup file can be configured by the user from the Automatic PDB/RTDB Backup screen.

Figure 2-9 Automatic PDB/RTDB Backup screen.

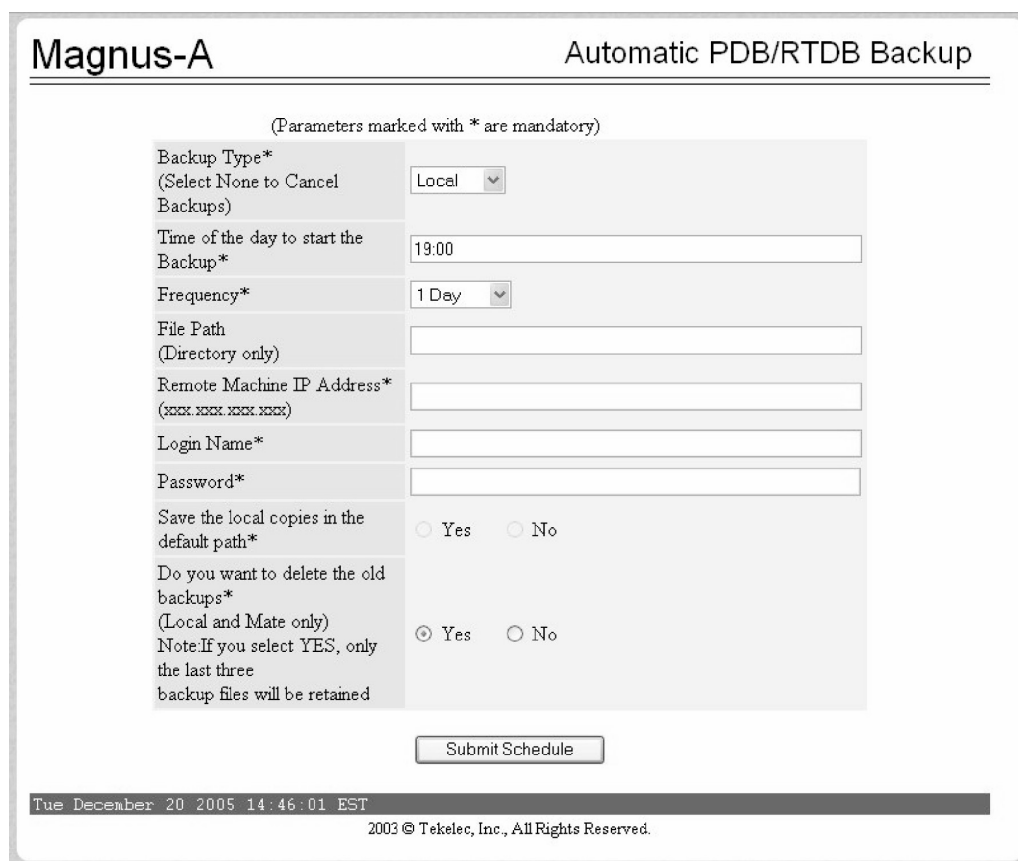

Magnus-A Automatic PDB/RTDB Backup

(Parameters marked with * are mandatory)

Backup Type*
(Select None to Cancel Backups) Local

Time of the day to start the Backup* 19:00

Frequency* 1 Day

File Path
(Directory only)

Remote Machine IP Address*
(xxx.xxx.xxx.xxx)

Login Name*

Password*

Save the local copies in the default path* Yes No

Do you want to delete the old backups*
(Local and Mate only)
Note: If you select YES, only the last three backup files will be retained Yes No

Submit Schedule

Tue December 20 2005 14:46:01 EST
2003 © Tekelec, Inc., All Rights Reserved.

Most of the input parameters are self explanatory. The following options are configurable by the user:

The frequency of the backup copy can be any of the following increments:

- 12 hours (see Note below)
- 1 Day (daily)
- 2 Days
- 3 Days
- 5 Days
- 7 Days

The Backup Type parameter is the destination for the backup file:

- **Local** - A backup copy of the data is saved to the local disk on the same **EPAP** server as the **PDB/RTDB** being backed up.
- **Mate** - A backup copy of the data is created on the local server and then sent via **SCP** to the mate **EPAP** server.
- **Remote** - A backup copy of the data file is created on the local **EPAP** server and then sent via **SFTP** to a remote server configured by the user. This server may or may not run **EPAP** software and can be any machine on the network that is running an **SFTP daemon** or service.

- **None** - No backup is scheduled and cancel all previously scheduled backups. This will not affect a backup that is currently in progress.

The following table can be used as a guide when scheduling the Automatic **PDB/RTDB** Backup.

Table 2-13 Mandatory verses Optional Parameters

Parameter	Automatic PDB/RTDB Backup Type		
	Local	Mate	Remote
Time of day to start backup	Mandatory	Mandatory	Mandatory
Frequency	Mandatory	Mandatory	Mandatory
File Path	Optional	Optional	Mandatory
Remote Machine IP Address	N/A	N/A	Mandatory
Login Name	N/A	N/A	Mandatory
Password	N/A	N/A	Mandatory
Save the Local copies in the default path	N/A	Optional	Mandatory
Do you want to delete the old backups Note: If you choose Yes, only the last three backup files, including the current one are kept.	Mandatory	Mandatory	N/A

The default file path where subdirectories are created (on the mate and local servers) is `/var/TKLC/epap/free/`

The default filenames that are used to designate the backup files are:

Table 2-14 Backup File Default Filenames

PDB	<code>pdbBackup_<hostname>_<CurrentTime>_DBBirthdate_<DBBirthdate>_DBLevel_<level>.bkp.tar.gz</code>
RTDB	<code>rtdbBackup_<hostname>_<CurrentTime>.tar.gz</code>

2.73 Automatic PDB Export Enhancement (EPAP 9.0)

Description

The Automatic PDB Export Enhancement feature provides more flexible scheduling for automatic PDBA exports.

With more options to choose from, scheduling an automatic PDB export is now very similar to the way tasks or appointments can be scheduled in a calendar manager.

In addition to the previously available choices for export format, mode, and data type, these enhancements allow the user to:

- View, modify, or delete existing reports
- Choose from multiple options for the frequency of the export:
 - Daily
 - Weekly

- Monthly
- Yearly
- Choose the time of day to start the export
- Add comments to describe the export

Hardware Requirements

None.

Limitations

None.

2.74 Backup Provisioning Network Interface (Release 29.0)

Currently, the **MPS** machines only make use of one interface to the customer network. There is an unused interface (**QFE3**) available. This feature allows for the configuring of a second interface to the customer network. This second interface must exist on a different subnet than the primary (**HME0**) interface. The customer can then use either interface to communicate with the **MPS** (WebUI, **PDBI**, telnet, etc).

 **Note:**

It is important to note that this backup interface could also be used for Versant's **FTS** replication, in the event that something is wrong with the **HME0** path. However, this switch is not automatic. A user would have to manually make the change through the configuration text **UI** at both sites.

Hardware Requirements

No new hardware is needed to support this feature.

2.75 Calling Name Conversion Facility (CNCF) (Release 23.1)

This feature provides a conversion of **ISUPIAM** messages using two versions of calling name identification presentation (**CNIP**) for calling name information delivery. One version of the **CNIP** uses the nonstandard, proprietary **ISUP** party information (**PIP**) parameter. The other version uses the **ANSI** standard **ISUP** generic name (**GN**) parameter. The conversion will either replace the **PIP** parameter with the **GN** parameter or the **GN** parameter with the **PIP** parameter in the **ISUPIAM** message.

The gateway screening feature is used to select which **ISUP** messages are converted. The incoming messages are selected based on the **OPC** and **DPC** in the routing label of the message, and the message type in the service information octet. The message type is defined by the value of the service indicator (**SI**) field of the **SIO**. **ISUP** messages contain the value 5 in the service indicator field of the **SIO**. Screening rules for **Allowed OPC**, **Allowed DPC**, and the **Allowed SIO** entities must be configured in the database for this feature. The `redirect=yes` parameter must be specified with

the last entity in the screening process (`nsfi=stop`) to use the **CNCF** feature to convert the message.

This feature is an optional feature and must be turned on with the `chg-feat` command and the new parameter, `cncf=on`. Before this feature can be turned on, the gateway screening feature must be on. This is shown by the entry `GWS = on` in the output of the `rtv-feat` command. If the gateway screening feature is not on when an attempt is made to turn the **CNCF** feature on, the `chg-feat` command is rejected with this message:

Error Message

```
E3646 Cmd Rej: GWS must be ON before CNCF can be ON
```

The `rtv-feat` command output has been changed to add the `CNCF` field showing whether the **CNCF** feature is on or not.

If the **CNCF** feature is turned on, the **DTA** feature is disabled. There are no other command changes to support this feature.

Figure 2-8 shows an example network that contains these two separate **ISUP** versions. Based on this example, Table 2-5 shows when the **ISUPIAM** message conversion by the **CNCF** feature occurs.

Figure 2-10 PIP/GN Parameter Conversion

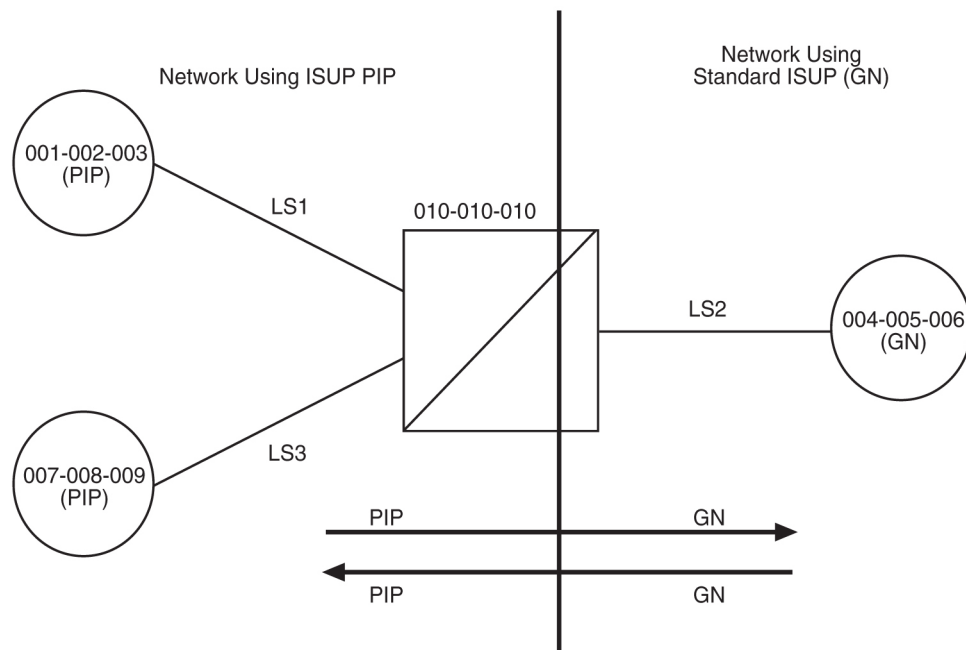

Table 2-15 ISUP IAM Message Conversion Examples

Origination Point Code	Destination Point Code	ISUPIAM Message Conversion
001-002-003	004-005-006	Yes

Table 2-15 (Cont.) ISUP IAM Message Conversion Examples

Origination Point Code	Destination Point Code	ISUPIAM Message Conversion
001-002-003	007-008-009	No
004-005-006	001-002-003	Yes
004-005-006	007-008-009	Yes
007-008-009	001-002-003	No
007-008-009	004-005-006	Yes

▲ Caution:

Take care when configuring the gateway screening rules for this feature. The **CNCF** feature has no way to validate the gateway screening rules to detect errors in converting messages between compatible networks. For example, using the example network in [Figure 2-8](#), the **ISUP IAM** message traffic from node 001-002-003 to node 007-008-009 does not need to be converted because they are using the same calling name delivery parameter, **PIP**. If the gateway screening rules are not carefully configured, these messages could be converted when they do not need to be.

Limitations

No measurements are collected showing the number of **MSUs** converted by this feature.

No error message is generated if an error occurs during the conversion of the **PIP** and **GN** parameters.

If the **CNCF** feature is turned on, the **DTA** feature is disabled. No message redirection using the **DTA** feature will be performed.

If the `copy=yes` parameter is specified with the `redirect=yes` parameter, the **MSU** is copied for the **STP LAN** feature after it has been converted by the **CNCF** feature.

If there are multiple **PIP** parameters or **GN** parameters with calling name information within a single **ISUPIAM**, only the first occurrence of the parameter in the **ISUPIAM** message is converted.

Messages on X.25 linksets cannot be converted with the **CNCF** feature.

Only **GNIAM** messages containing calling name information (Type of Name = Calling Name, Presentation = Allowed, Parameter Length >1) are converted to **PIPIAM** messages.

Only **PIPIAM** messages containing Calling Name Information (Sub-Parameter Code = Name Information, Name Element Indicator = Calling Party) are converted to **GNIAM** messages.

If the received **IAM** message contains both a **GN** and a **PIP** parameter with calling name information, the **GN** parameter is retransmitted and the **PIP** parameter is deleted.

Any **MSU** that is not converted is simply retransmitted. These **MSUs** include non-**ISUPMSUs**, non-**IAMMSUs**, and any **IAMMSU** received that does not contain either a **GN** or **PIP** parameter.

If the **PIP** parameter contains other information in addition to the calling party name information, only a **GN** parameter containing calling party name information is generated.

The linkset being screened for this feature should not contain C links (`lst=c` parameter of the `ent-ls` and `chg-ls` commands). This would result in the double conversion of the **ISUPIAM** messages.

IAM messages containing a **GN** parameter that are to be converted, must be 262 bytes or less. The **ANSISS7MSU** can contain a maximum of 272 bytes, including the Level 3 routing label. Without the routing label, the **MSU** can contain 265 bytes, starting at the Circuit **ID** code field. Since the **PIP** parameter has 3 bytes more than the **GN** parameter, the **MSU** can contain a maximum of 262 bytes.

Table 2-6 summarizes the conversion action performed based on the optional parameters found within the **MSU**.

Table 2-16 CNCF Conversion Actions

PIP Parameter Content	GN Parameter Content		
	GN Parameter with Calling Name Information	GN Parameter without Calling Name Information	GN Parameter Not Found
PIP Parameter with Calling Name Information	The PIP parameter is deleted. The GN parameter is retransmitted without conversion. No network-specific parameters (0xFD and 0xFE) are deleted.	The PIP parameter is converted to a GN parameter. The GN parameter is retransmitted if it is present. Network-specific parameters (0xFD and 0xFE) are deleted.	The PIP parameter is converted to a GN parameter. The GN parameter is retransmitted if it is present. Network-specific parameters (0xFD and 0xFE) are deleted.
PIP Parameter without Calling Name Information	The PIP parameter is deleted. The GN parameter is retransmitted without conversion. No network-specific parameters (0xFD and 0xFE) are deleted.	The PIP parameter is deleted. The GN parameter is retransmitted if it is present. Network-specific parameters (0xFD and 0xFE) are deleted.	The PIP parameter is deleted. The GN parameter is retransmitted if it is present. Network-specific parameters (0xFD and 0xFE) are deleted.
PIP Not Found	The PIP parameter is not involved. The GN parameter is converted to PIP . No network-specific parameters (0xFD and 0xFE) are deleted.	No parameters are converted. No parameters are deleted.	No parameters are converted. No parameters are deleted.

Table 2-16 (Cont.) CNCF Conversion Actions

PIP Parameter Content	GN Parameter Content		
	GN Parameter with Calling Name Information	GN Parameter without Calling Name Information	GN Parameter Not Found

 **Note:**
 Parameters with calling name information have precedence over parameters without calling name information. For example, an **MSU** that has both a **GN** parameter with calling name information and a **GN** parameter without calling name information is treated as if it were an **MSU** with a **GN** parameter with calling name information.

PIP and GN Parameters

The **PIP** format contains a parameter name (0xFC), parameter length and optional sub-parameters. The format is shown in [Table 2-7](#). The Name Element Indicator, Name Element Length and Name Information fields can be repeated within a single **PIP**.

Table 2-17 PIP Parameter Format

Field	Length	Bits Value HGFEDC BA	Comments
Parameter Name	1 octet	1111 1100	Party Information
Parameter Length	1 octet	—	Length of the parameter excluding the parameter name and the parameter length octet
Sub-Parameter Code	1 octet	1111 1110	Name Information
Sub-Parameter Length	1 octet	—	Sum of the number of octets in the Name Element Indicator, Name Element Length, and Name Information fields
Name Element Indicator	1 octet	0000 0001 0000 0010 0000 0011	Calling party name Connected party name Redirecting party name
Name Element Length	1 octet	—	Number of characters in the name information field (maximum of 15)
Name Information	up to 15 octets	—	Maximum of 15 IA5 characters

The **GN** format contains a parameter name (0xC7), parameter length and up to 16 additional octets. The format is shown in [Table 2-8](#).

Table 2-18 GN Parameter Format

Field		Bits Value HGFEDCBA	Comments
Parameter Name		1100 0111	Generic Name
Parameter Length		—	Length of the parameter excluding the parameter name and length fields
Octet 1	Presentation	XXXXXX00	Presentation Allowed
		XXXXXX01	Presentation Restricted
		XXXXXX10	Blocking Toggle
		XXXXXX11	No indication
	Spare	XXXX 00XX	Not Used
	Availability	XXX0XXXX	Name available or name availability unknown
		XXX1XXXX	Name not available
		Type of name	000X XXXX
	001X XXXX		Calling name
	010X XXXX		Original called name
	011X XXXX		Redirecting name
	100X XXXX		Connected name
		101X XXXX to 111X XXXX	Spare
Octets 2-n		—	

Maximum of 15 characters

Conversion of PIP to GN

The mapping of **PIP** parameters to **GN** parameters for this conversion is shown in [Figure 2-9](#). The new **GN** parameter length field is computed based on the **PIP** name element length and not the **PIP** parameter length or Sub-Parameter length fields.

Figure 2-11 PIP to GN Parameter Mapping

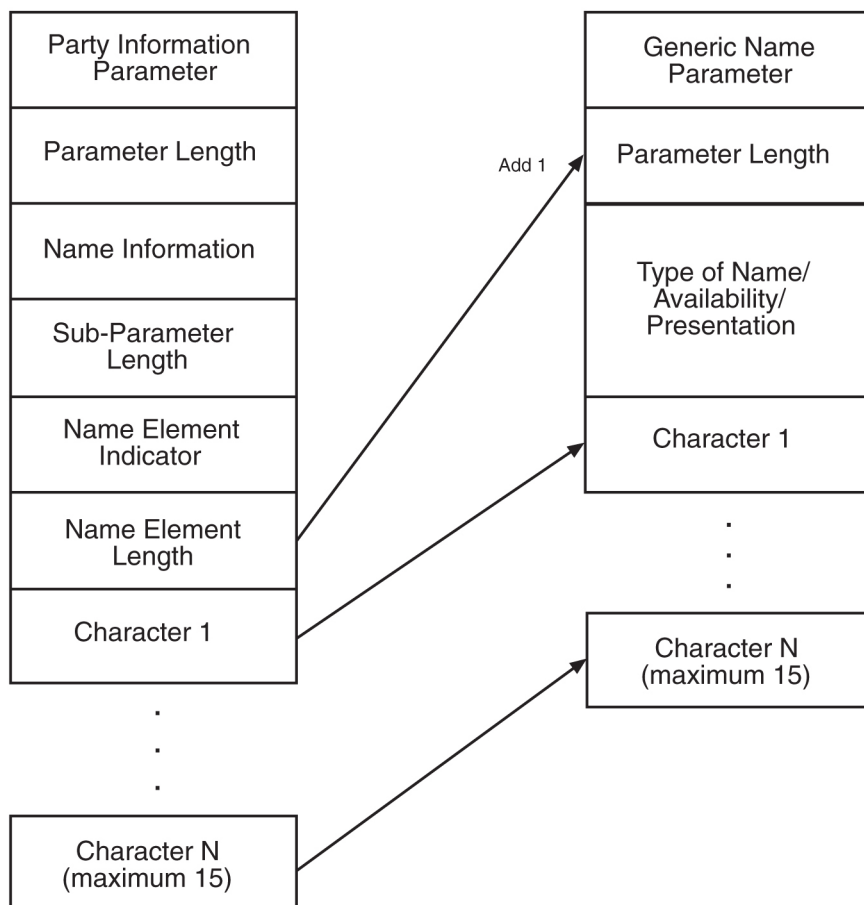

Conversion of GN to PIP

The mapping of **GN** parameters to **PIP** parameters for this conversion is shown in [Figure 2-10](#).

Figure 2-12 GN to PIP Parameter Mapping

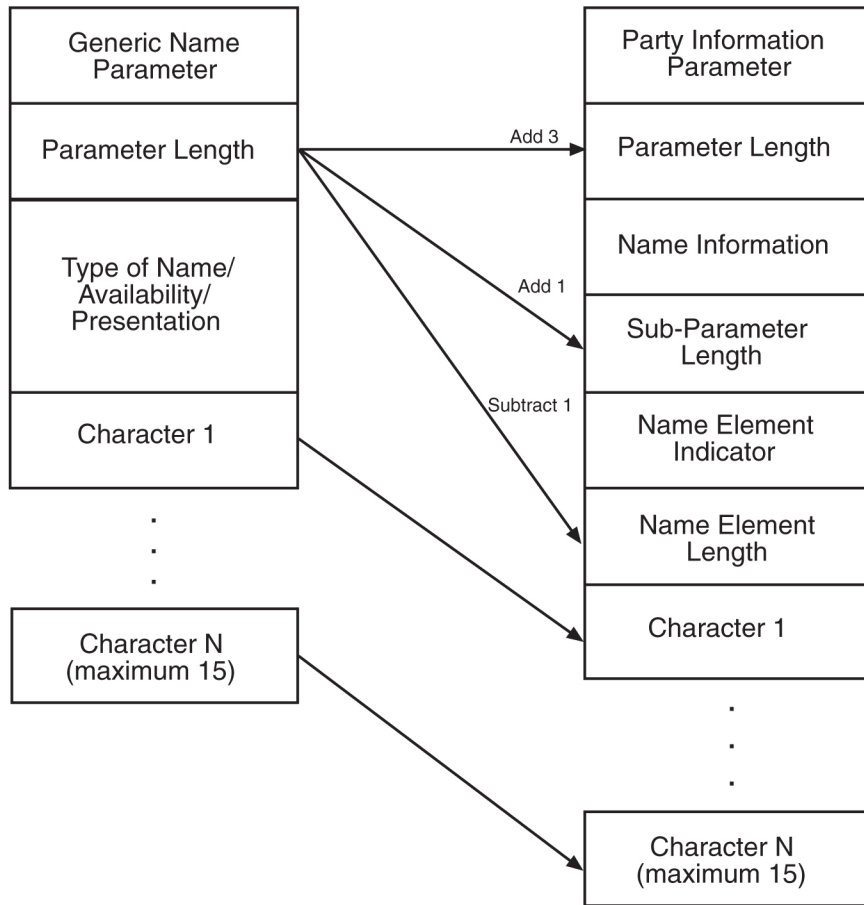

Table 2-9 shows how the **PIP** and **GN** parameters are mapped during the conversion process.

Table 2-19 PIP/GN Parameter Mapping

Party Information Parameter		Generic Name Parameter	
Field Name	Value	Field Name	Value
Parameter Name	Party Information (0xFC)	Parameter Name	Generic Name (0xC7)
Parameter Length	as calculated	Parameter Length	as calculated
Sub-Parameter Code	Name Information (0xFE)	—	no mapping
Sub-Parameter Length	as calculated	—	no mapping
Name Element Indicator	Calling Party Name (1)	Type of Name	Calling Name (HGF=001)
—	no mapping	Presentation	Allowed (BA=0)
—	no mapping	Availability	Name Available (E=0)
Name Element Length	as calculated	—	no mapping
Name Information	Calling Party Name (maximum 15 characters)	Characters	Calling Party Name (maximum 15 characters)

Message Conversion

The conversion process only occurs in **ISUP** Initial Address Messages (**IAM**) with either the **PIP** or **GN** optional parameters that contain calling party name information. The conversion either replaces **PIP** parameters with **GN** parameters or **GN** parameters with **PIP** parameters. In some cases, network-specific optional parameters are also deleted from the message. The Level 2 Length Indicator is also updated since the **MSU** length is changing. The sections shown in bold type show which fields of an **IAM** with the **GN** parameter are effected by the **CNCF** feature.

Output Example

```

Protocol Flavor: ANSI-SS7
Total Message Length: 56
*** Start of MTP Level 2 ***
      MTP
000 00000000 00
      -0000000    Backward Sequence Number          0
      0-----    Backward Indicator Bit            0
001 00000000 00
      -0000000    Forward Sequence Number           0
      0-----    Forward Indicator Bit             0
002 00110101 35
      --110101    Length Indicator                  53
      00-----    Spare                            0
*** Start of MTP Level 3 ***
      MSU
003 10000101 85
      ----0101    Service Indicator                  0101 - ISDN
User Part
      --00----- Network Priority                  00 - priority
0
      10-----    Network Indicator                 10 - National
Network
004 00000110 06 Destination Point Code              4-5-6
005 00000101 05
006 00000100 04
007 00000011 03 Origination Point Code              1-2-3
008 00000010 02
009 00000001 01
010 00000000 00 Signaling Link Selection            0
*** Start of ISDN User Part ***
      Initial address Message
011 00000000 00 Circuit Identification Code          0
012 00000000 00
      --0000000
      00-----    Spare                            0
013 00000001 01 Message Type                        01
      Nature of connection indicators
014 00000000 00
      -----00    Satellite Indicator               00 - no
satellite in the connection
      ----00--    Continuity check indicator         00 -
continuity check not required

```

```

    ---0----    Echo Control Device Indicator          0 - outgoing half
echo cntrl dev not inc
    000-----    Spare                                0
    Forward call indicators
015 00000000 00
    -----0    Incoming International Call Indicator  0 - not an incoming
international call
    -----00-   End-to-End Method Indicator          00 - no end-to-end
method available
    ----0----   Interworking Indicator              0 - no interworking
encountered -all SS7
    ---0----   IAM Segmentation Indicator            0 - no indication
    --0-----   ISDN User Part Indicator            0 - ISDN user part
not used all the way
    00-----   ISDN User Part Preference Indicator   00 - ISDN-UP
preferred all the way
016 00000000 00
    -----0    ISDN Access Indicator                0 - originating
access non-ISDN
    -----00-   SCCP Method Indicator              00 - no indication
    ----0----   Spare                                0
    0000----   Reserved for National Use           0
    Calling party's category
017 00000010 02 Calling party's category            00000010 -
operator, language English
    Variable Portion
018 00000011 03 User service information Pointer      Offset 021
019 00000101 05 Called party number Pointer         Offset 024
020 00010001 11 Optional Portion Pointer           Offset 037
    User service information
021 00000010 02 User service information Length      2
    Octet 3
022 11000000 c0
    ---00000    Information transfer capability       00000 - speech
    -10-----   Coding Standard                    10 - national
standard
    1-----    Extension                            01
    Octet 4
023 10010000 90
    ---10000    Information transfer rate            10000 - 64 kbit/s
    -00-----   Transfer mode                      00 - circuit mode
    1-----    Extension 4                          Excluded
    User information layers
    Called party number
024 00001100 0c Called party number Length          12
025 00000011 03
    -0000011    Nature of address indicator          national
(significant) number
    0-----    Odd/even indicator                  0 - even number of
address signals
    Octets 2-10
026 00010000 10
    ----0000    Spare                                00
    -001-----   Numbering plan                    001 -
ISDN(Telephony) numbering plan

```

```

        0----- Spare                                00
027 00100001 21 Address
12345678901234567890
028 01000011 43
029 01100101 65
030 10000111 87
031 00001001 09
032 00100001 21
033 01000011 43
034 01100101 65
035 10000111 87
036 00001001 09

        Optional Portion
        Generic Name
037 11000111 c7 Generic Name Type                    199
038 00010000 10 Generic Name Length                  16
039 00100000 20
        -----00 Presentation                        00 -
Presentation Allowed
        ----00-- Spare                                00
        ---0---- Availability                          0 - Name
available, or unknown
        001----- Type of Name                        01
040 01000001 41 NAME
ABCDEFGHIJKLMNO
041 01000010 42
042 01000011 43
043 01000100 44
044 01000101 45
045 01000110 46
046 01000111 47
047 01001000 48
048 01001001 49
049 01001010 4a
050 01001011 4b
051 01001100 4c
052 01001101 4d
053 01001110 4e
054 01001111 4f
055 00000000 00 End of optional parameters            00
    
```

The sections shown in bold type show which fields of an IAM with the PIP parameter are effected by the CNCF feature.

Output Example

```

Protocol Flavor: ANSI-SS7
Total Message Length: 59
*** Start of MTP Level 2 ***
        MTP
000 00000000 00
        -0000000 Backward Sequence Number            0
        0----- Backward Indicator Bit              0
001 00000000 00
    
```

```

    -0000000    Forward Sequence Number          0
    0-----    Forward Indicator Bit            0
002 00111000 38
    --111000    Length Indicator                56
    00-----    Spare                          0
*** Start of MTP Level 3 ***
    MSU
003 10000101 85
    ----0101    Service Indicator                0101 - ISDN User
Part
    --00----- Network Priority                00 - priority 0
    10-----    Network Indicator              10 - National
Network
004 00000110 06 Destination Point Code          4-5-6
005 00000101 05
006 00000100 04
007 00000011 03 Origination Point Code          1-2-3
008 00000010 02
009 00000001 01
010 00000000 00 Signaling Link Selection        0
*** Start of ISDN User Part ***
    Initial address Message
011 00000000 00 Circuit Identification Code      0
012 00000000 00
    --000000
    00-----    Spare                          0
013 00000001 01 Message Type                    01
    Nature of connection indicators
014 00000000 00
    -----00    Satellite Indicator              00 - no satellite
in the connection
    ----00--    Continuity check indicator        00 - continuity
check not required
    ---0-----    Echo Control Device Indicator    0 - outgoing half
echo cntrl dev not inc
    000-----    Spare                          0
    Forward call indicators
015 00000000 00
    -----0    Incoming International Call Indicator  0 - not an incoming
international call
    -----00-    End-to-End Method Indicator        00 - no end-to-end
method available
    ----0---    Interworking Indicator              0 - no interworking
encountered -all SS7
    ---0-----    IAM Segmentation Indicator          0 - no indication
    --0-----    ISDN User Part Indicator            0 - ISDN user part
not used all the way
    00-----    ISDN User Part Preference Indicator  00 - ISDN-UP
preferred all the way
016 00000000 00
    -----0    ISDN Access Indicator                0 - originating
access non-ISDN
    -----00-    SCCP Method Indicator              00 - no indication
    ----0---    Spare                          0
    0000----- Reserved for National Use          0

```

```

                Calling party's category
017 00000010 02 Calling party's category          00000010 -
operator, language English
                Variable Portion
018 00000011 03 User service information Pointer   Offset 021
019 00000101 05 Called party number Pointer      Offset 024
020 00010001 11 Optional Portion Pointer         Offset 037
                User service information
021 00000010 02 User service information Length   2
                Octet 3
022 11000000 c0
    ---00000   Information transfer capability     00000 -
speech
    -10----- Coding Standard                   10 - national
standard
    1-----   Extension                          01
                Octet 4
023 10010000 90
    ---10000   Information transfer rate          10000 - 64
kbit/s
    -00----- Transfer mode                     00 - circuit
mode
    1-----   Extension 4                       Excluded
                User information layers
                Called party number
024 00001100 0c Called party number Length       12
025 00000011 03
    -0000011   Nature of address indicator        national
(significant) number
    0-----   Odd/even indicator                 0 - even
number of address signals
                Octets 2-10
026 00010000 10
    ----0000   Spare                             00
    -001----- Numbering plan                   001 -
ISDN(Telephony) numbering plan
    0-----   Spare                             00
027 00100001 21 Address
12345678901234567890
028 01000011 43
029 01100101 65
030 10000111 87
031 00001001 09
032 00100001 21
033 01000011 43
034 01100101 65
035 10000111 87
036 00001001 09
                Optional Portion
                Party Information Parameter
037 11111100 fc Party Information Parameter Type  252
038 00010011 13 Party Information Parameter Length 19
039 11111110 fe Sub-Parameter Code              254 - Name
Information
040 00010001 11 Sub-Parameter Length            17

```

```

041 00000001 01 Name Element Indicator           01 - Calling Party
Name
042 00001111 0f Name Element Length           15
043 01000001 41 Name Information               ABCDEFGHIJKLMNO
044 01000010 42
045 01000011 43
046 01000100 44
047 01000101 45
048 01000110 46
049 01000111 47
050 01001000 48
051 01001001 49
052 01001010 4a
053 01001011 4b
054 01001100 4c
055 01001101 4d
056 01001110 4e
057 01001111 4f
058 00000000 00 End of optional parameters      00
    
```

2.76 Calling Name Conversion Facility (CNCF) with Redirect Capability (Release 24.0)

Description

This feature provides a conversion of **ISUP IAM** messages using two versions of calling name identification presentation (**CNIP**) for calling name information delivery. One version of the **CNIP** uses the nonstandard, proprietary **ISUP** party information (**PIP**) parameter. The other version uses the **ANSI** standard **ISUP** generic name (**GN**) parameter. The conversion will either replace the **PIP** parameter with the **GN** parameter or the **GN** parameter with the **PIP** parameter in the **ISUP IAM** message.

The gateway screening feature is used to select which **ISUP** messages are converted. The incoming messages are selected based on the **OPC** and **DPC** in the routing label of the message, and the message type in the service information octet. The message type is defined by the value of the service indicator (**SI**) field of the **SIO**. **ISUP** messages contain the value 5 in the service indicator field of the **SIO**. Screening rules for **Allowed OPC**, **Allowed DPC**, and the **Allowed SIO** entities must be configured in the database for this feature.

Refer to the *Database Administration Manual - Gateway Screening* for details on using this feature.

Unsolicited Information Messages

The commands `chg-scr-aftpc`, `chg-scr-cdpa`, `chg-scr-cgpa`, `chg-scr-tt`, `ent-scr-aftpc`, `ent-scr-cdpa`, `ent-scr-cgpa`, and `ent-scr-tt` cannot use any entry shown in the `rtrv-gws-actset` command output that contains the redirect stop action (**RDCT**) or the **CNCF** stop action (**CNCF**). This restriction is not enforced when the `chg-gws-actset` and the `chg-scr-aftpc`, `chg-scr-cdpa`, `chg-scr-cgpa`, `chg-scr-tt`, `ent-scr-aftpc`, `ent-scr-cdpa`, `ent-scr-cgpa`, and `ent-scr-tt` commands are entered into the database. The database will accept these commands using entries from the gateway screening stop action table, but when the **EAGLE** encounters **MSUs** that pass gateway screening at the **AFTPC**, **CDPA**, **CGPA** or **TT** screens, these **UIMs** (unsolicited information

messages) are generated indicating that gateway screening received a **MSU** that could not be redirected or converted.

UIM 1125 – Gateway Screening received a Called Party Address that could not be Redirected for the DTA feature

```
RLGHNCXA03W 99-01-07 00:57:31 EST Rel 24.0.0
1001.1125    CARD 1103,A  INFO          GWS rcvd CDPA that could not be
RDCTd
                SIO=03    OPC=001-001-001  DPC=002-002-002
                SCCP MT= 18
                CDPA:  AI=10  PC=003-003-003  SSN=005  TT=250
ADDR=1234567890
                CGPA:  AI=10  PC=004-004-004  SSN=005  TT=251
ADDR=1234567890
                SR=scrib  LSN=A1234567
                Report Date: 98-09-07  Time: 16:27:19
```

UIM 1126 – Gateway Screening received a Calling Party Address that could not be Redirected for the DTA feature

```
RLGHNCXA03W 99-01-07 00:57:31 EST Rel 24.0.0
1002.1126    CARD 1103,A  INFO          GWS rcvd CGPA that could not be
RDCTd
                SIO=03    OPC=001-001-001  DPC=002-002-002
                SCCP MT= 18
                CDPA:  AI=10  PC=003-003-003  SSN=005  TT=250
ADDR=1234567890
                CGPA:  AI=10  PC=004-004-004  SSN=005  TT=251
ADDR=1234567890
                SR=scrib  LSN=A1234567
                Report Date: 98-09-07  Time: 16:27:19
```

UIM 1127 – Gateway Screening received an Affected Point Code that could not be Redirected for the DTA feature

```
RLGHNCXA03W 99-01-07 00:57:31 EST Rel 24.0.0
1003.1127    CARD 1103,A  INFO          GWS rcvd AFTPC that could not
be RDCTd
                SIO=03    OPC=001-001-001  DPC=002-002-002
                SCCP MT= 18
                CDPA:  AI=10  PC=003-003-003  SSN=005  TT=250
ADDR=1234567890
                CGPA:  AI=10  PC=004-004-004  SSN=005  TT=251
ADDR=1234567890
                SR=scrib  LSN=A1234567
                Report Date: 98-09-07  Time: 16:27:19
```

UIM 1128 – Gateway Screening received a Translation Type that could not be Redirected for the DTA feature

```
RLGHNCXA03W 99-01-07 00:57:31 EST Rel 24.0.0
1004.1128   CARD 1103,A  INFO          GWS rcvd TT that could not be RDCTd
SIO=03   OPC=001-001-001  DPC=002-002-002
SCCP MT= 18
CDPA:  AI=10  PC=003-003-003  SSN=005  TT=250  ADDR=1234567890
CGPA:  AI=10  PC=004-004-004  SSN=005  TT=251  ADDR=1234567890
SR=scrib  LSN=A1234567
Report Date: 98-09-07  Time: 16:27:19
```

UIM 1215 – Gateway Screening received a Called Party Address that could not be processed by the Calling Name Conversion Facility feature

```
RLGHNCXA03W 99-01-07 00:57:31 EST Rel 24.0.0
1005.1215   CARD 1103,A  INFO          GWS rcvd CDPA that could not be CNCFd
SIO=03   OPC=001-001-001  DPC=002-002-002
SCCP MT= 18
CDPA:  AI=10  PC=003-003-003  SSN=005  TT=250  ADDR=1234567890
CGPA:  AI=10  PC=004-004-004  SSN=005  TT=251  ADDR=1234567890
SR=scrib  LSN=A1234567
Report Date: 98-09-07  Time: 16:27:19
```

UIM 1216 – Gateway Screening received a Calling Party Address that could not be processed by the Calling Name Conversion Facility feature

```
RLGHNCXA03W 99-01-07 00:57:31 EST Rel 24.0.0
1006.1216   CARD 1103,A  INFO          GWS rcvd CGPA that could not be CNCFd
SIO=03   OPC=001-001-001  DPC=002-002-002
SCCP MT= 18
CDPA:  AI=10  PC=003-003-003  SSN=005  TT=250  ADDR=1234567890
CGPA:  AI=10  PC=004-004-004  SSN=005  TT=251  ADDR=1234567890
SR=scrib  LSN=A1234567
Report Date: 98-09-07  Time: 16:27:19
```

UIM 1217 – Gateway Screening received an Affected Point Code that could not be processed by the Calling Name Conversion Facility feature

```
RLGHNCXA03W 99-01-07 00:57:31 EST Rel 24.0.0
1007.1217   CARD 1103,A  INFO          GWS rcvd AFTPC that could not be CNCFd
SIO=03   OPC=001-001-001  DPC=002-002-002
SCCP MT= 18
CDPA:  AI=10  PC=003-003-003  SSN=005  TT=250  ADDR=1234567890
CGPA:  AI=10  PC=004-004-004  SSN=005  TT=251  ADDR=1234567890
SR=scrib  LSN=A1234567
Report Date: 98-09-07  Time: 16:27:19
```

UIM 1218 – Gateway Screening received a Translation Type that could not be processed by the Calling Name Conversion Facility feature

```

RLGHNCXA03W 99-01-07 00:57:31 EST Rel 24.0.0
1008.1218 CARD 1103,A INFO GWS rcvd TT that could not be
CNCFd
      SIO=03 OPC=001-001-001 DPC=002-002-002
      SCCP MT= 18
      CDPA: AI=10 PC=003-003-003 SSN=005 TT=250
ADDR=1234567890
      CGPA: AI=10 PC=004-004-004 SSN=005 TT=251
ADDR=1234567890
      SR=scrib LSN=A1234567
      Report Date: 98-09-07 Time: 16:27:19

```

In order to stop these **UIMs** from being generated, the gateway screening rule shown in the **UIM** must be identified. Once the gateway screening rule has been identified, a gateway screening change command can be used either to remove the gateway screening action set name or change the gateway screening action set name to a different gateway screening action set not containing the **CNCF** or redirect gateway screening stop actions. The gateway screening stop action set can also be changed with the `chg-gws-actset` command to remove the redirect or **CNCF** gateway screening stop actions. However, this could keep other gateway screening rules from redirecting or converting **MSUs** passing gateway screening from the **BLKOPC**, **BLKDPC**, **SIO**, **OPC**, **DPC**, or **DESTFLD** screens.

2.77 CDU for DSM (Release 26.05)

CDU (**CAP** Downloadable Utility) is an existing software platform for diagnostics used by manufacturing in identifying and isolating expansion memory problems in the **EAGLE** cards quickly and reliably. This feature ports the existing **CDU** and provides an efficient “go/no go” memory test for the **DSM/DCM** card.

CDU Port

The existing **CDU** utility has been ported for the **DSM/DCM** card, and a new **GPL VCDU** has been created. The new **GPL** has all the existing functionality. The **DSM** board can hold up to 4GB of memory. The **CDU** or the **VCDU** utility is downloaded automatically, depending on the type of the board. For the **DSM**, the **VCDU** utility is downloaded; for the other boards, the **CDU** utility is downloaded.

The **CDU** or the **VCDU** can be downloaded into any card with the following command:

```
alw-card:loc=xxxx:code=utility
```

The following `act-memtst` command used with the parameter set to “fast” lets the **VCDU** utility test 4GB of memory in 4 hours:

```

cdu:loc=xxxx:cmd=
" ACT-MEMTST:BEG=H'100000:END=H'200000 :TYPE=FAST
"

```

Quick Test

The quick go/no go test is implemented with the `ACT-QCKTST` command in **CDU/VCDU**. Using this command, the **VCDU** utility can check the basic integrity of the memory within 10 minutes. This test includes verifying the address and data lines to the memory, and verifying accessibility of each memory chip of 4GB.

Ping Test

The **VCDU** utility uses a new command, `act-pingtst`, to test the network. The ping test applies to the **DCM/DSM** card only.

```
cdu:loc=xxxx:cmd=
" act-pingtst:port=<a/b>:dest=<ip_address> :router=<router>:loop=n
"
```

This command activates the ping test. The `port` parameter specifies the origination address. The `dest` parameter specifies the destination address to be pinged. The `router` parameter is an optional parameter that specifies the router through which the network interface can be tested. The `loop` parameter specifies the number of times the test should be run before termination.

2.78 CgPA GWS Routing Indicator Enhancement (Release 31.3)

The wildcarding of the **CgPA** routing indicator (**RI=***) produced 2 entries in the **GWS** database on the **LIM** card; that reduced the number of **CgPA** rules available to the customer from 4000 to 2000 per screenset.

The wildcarding has been changed to produce a single database entry for wildcard (*) of the routing indicator in **CgPA GWS** screening rules. The **EAGLE** does not expand the provisioned wildcard routing indicator into multiple rules in the bound screenset.

Upgrade to Release 31.3 auto consolidates existing entries that were provisioned with **RI=***.

2.79 Change Default ATM CLP Bit for Data Cells from 1 to 0 (Release 31.3)

The Cell Loss Priority (**CLP**) bit is in the **ATM** packet header and is used by **ATM** network elements to determine which messages are discarded when an **ATM** network element is in congestion. Should there be congestion in an **ATM** network element, it will first start to discard **ATM** packets with a **CLP** bit of 1 first before discarding any **ATM** packets with a **CLP** bit of 0. The **CLP** bit has the following characteristics:1. The **CLP** bit for **ATM-SS7** signaling (data cells) is specified to be either be 0 or 1 and is not specifically assigned a default value in **GR-2878 CORE (ANSI)** nor **I.361 (ITU)**. The **CLP** bit for **ATM** unassigned/idle (filler) cells is specified to be 0 for **T1** interfaces and 1 for **E1** interfaces. **ATM** equipment is required to discard these cells upon receipt and therefore the **CLP** bit for unassigned/idle (filler) cells will remain unchanged.2. The **CLP** bit for **ATM-SS7** signaling (data cells) is used by **ATM** network equipment much in a similar fashion as the priority field is used by **TDM SS7** equipment 3. The **CLP** bit determines how important a message is when an **ATM** network node is in congestion and needs to discard messages/packets. Currently, the **CLP** bit for **ATM-SS7** signaling (data cells) is a non-configurable value in the **EAGLE ATM** header that is defaulted to 1 for both **LIM-ATM (ANSI)** and **E1-ATM (ITU)** cards. Effective in Release 31.3, this default

will be changed to 0 (higher priority). The new **CLP** bit value of 0 has a higher priority than the current **CLP** bit value of 1.

2.80 Changeover and Changeback Procedure for Processor Outage and LIN (Release 21.0)

Currently, the **EAGLE** performs a sequence controlled changeover instead of a time-controlled changeover when the signaling link gets locally or remotely inhibited or when a local or remote processor outage condition is entered. In these cases, sending a changeover order could result in failure of the signaling link. The **EAGLE** also sends **SIPOs** when a signaling link is remotely or locally inhibited and also performs a sequence controlled changeover by sending a changeover order to the remote end.

With this release, the **EAGLE** now performs a time controlled changeover under these conditions. The **EAGLE** behaves in the following manner:

- When the signaling link is inhibited locally or remotely, the **EAGLE** does not send **SIPOs**. Instead a time diversion changeover procedure is started for the inhibited signaling link.
- When the signaling link is unavailable because of a remote or local processor outage, a time controlled changeover is performed instead of sequence controlled changeover.

If a changeover order is received for the unavailable link, while the level 3 **T1** timer is in progress, the buffer updating procedure and sequence controlled changeover is performed. The **EAGLE** responds with an emergency changeover acknowledgment if the changeover order is received after the level 3 **T1** timer has expired.

This feature applies to both **ANSI** and **ITU** signaling links. This feature has no impact on X.25 gateway signaling links since the inhibit and processor outage procedures are not used in the X.25 protocol.

2.81 Cluster Routing and Management Diversity (Release 21.0)

Description

The cluster routing and management diversity feature eliminates the need for a full point code entry in the routing table to route to every signaling point in every network. The cluster routing and management diversity feature allows the **EAGLE** to configure one route set to a entire cluster of destinations. This allows the **EAGLE** to manage and switch traffic to more end nodes.

A cluster is defined as a group of signaling points whose point codes have identical values for the network and cluster fields of the point codes. A cluster entry in the routing table is shown with an asterisk (*) in the member field of the point code, for example, 111-011-*. **Cluster** entries can only be provisioned as **ANSI** destination point codes. **ANSI** destination point codes can be specified as either a full point code, for example, 123-043-045, or as a cluster of signaling point codes, for example, 111-011-*.

Provisioning of clusters as well as full point codes that belong to the same cluster as destination point codes is also supported. The point codes 111-011-*, 111-011-005 and 111-011-045 entries can be provisioned. The cluster destination point code 111-011-*

represents all the point codes of the cluster except for point codes 111-011-005 and 111-011-045. **Cluster** entries in the destination point code table can also be used as a destination point code (**DPC**) for a route. A group of such routes with varying relative cost forms a routeset to a cluster just like a routeset to a full point code.

Exception Lists (X-lists)

An exception list for a cluster is a list of point codes in a cluster whose route status is more restricted than the corresponding route status of that cluster. The term “more restricted” is used when comparing the route status of a cluster member to the route status of the cluster. A **PROHIBITED** status is more restrictive than a **RESTRICTED** status and a **RESTRICTED** status is more restrictive than an **ALLOWED** status. This list contains point codes that are not assigned to any individual routeset and the only routesets to that node is through a cluster routeset. The exception list is a dynamic list that changes when the status of the cluster routeset or any member routesets in that cluster changes.

For each cluster, the user can specify an exception list exclusion indicator (**ELEI**) when configuring the cluster point code with the `ent-dstn` command. When the **ELEI** is `yes`, the **EAGLE** does not maintain exception list entries. When the **ELEI** is `no`, the **EAGLE** maintains exception list entries.

Exception list entries are stored as an extension of the destination point code table, which can contain up to 2500 entries. The **EAGLE** allows the user to specify the number of entries reserved for the exception list, between 500 to 2000 entries. The remainder of the 2500 entries in the destination point code table are reserved for the full and cluster point codes.

The outputs of the `ent-dstn`, `dlt-dstn`, `chg-dstn`, and `rtrv-dstn` commands display the following destination point code usage information.

- The number of configured full point codes
- The number of configured cluster point codes
- The sum of configured destinations (full and cluster point codes)
- The number of entries reserved for configured destinations (full and cluster point codes). This number is 2500 minus the number of entries reserved for the exception list.
- The number of entries reserved for exception list

There is an **STP**-wide expiration time value for exception list entries. This timer specifies the amount of time an idle exception list entry can be in the exception list before it is discarded. When this timer expires, unsolicited information message (**UIM**) 1146, **REPT-SLST-TIMO: X-LIST** entry expired, is displayed on the terminal and the specified exception list entry is discarded. The following is an example of **UIM** 1146.

Output Example:

```
RLGHNCXA03W 96-04-16 16:21:11 EDT Rel 21.0.0
1234.1146     CARD 1101     INFO REPT-XLST-TIMO: X-LIST entry expired
              DPC=011-212-033
Report Date: 96-04-16 Time: 16:20:19
```

In this example, the point code (**DPC**) 011-212-033 was in the exception list, the timer expired, and the point code was discarded from the exception list.

The value of the exception list timer is shown in the **MTPXLET** field of the `rtrv-stpopts` command output and is configured with the `mtpxlet` parameter of the `chg-stpopts` command.

The `rtrv-stpopts` command output contains three other fields that show the parameters of the exception list, **MTPXLQ**, **MTPXLOT**, and **MTPDPCQ**.

The **MTPXLQ** field shows the maximum number of entries the exception list (x-list) can contain. This value is configured with the `mtpxlq` parameter of the `chg-stpopts` command.

The **MTPXLOT** field shows the exception list (x-list) occupancy threshold (in terms of the percentage of the exception list space being used). The percentage of occupancy threshold is configured with the `mtpxlot` parameter of the **chg-stpopts** command. The default value for the threshold is 90%. For example, if there are 1500 entries configured for the exception list and the exception list contains 1000 entries, the percentage of the exception list space being used is 66%. If this threshold is exceeded, a minor alarm, unsolicited alarm message (**UAM**) 321, **X-LIST** occupancy threshold exceeded, is displayed. The following is an example of **UAM** 321.

UAM Messages

```
RLGHNCXA03W 96-04-16 16:21:11 EDT Rel 21.0.0
* 0061.0321 * XLIST X-LIST occupancy threshold
exceeded
```

The **MTPDPCQ** field shows the maximum number of destination point codes that can be configured in the **EAGLE**.

The **EAGLE** raises a major alarm, **UAM** 338, **X-LIST** space full-entry(s) discarded, when the exception list becomes completely full and the **EAGLE** fails to create any more exception list entries. The following is an example of **UAM** 338.

```
RLGHNCXA03W 96-04-16 16:21:11 EDT Rel 21.0.0
** 0055.0338 ** SYSTEM X-LIST space full-entry(s)
discarded
```

An exception list entry's expiration timer is restarted when an exception list entry gets created, updated, or used for routing. This expiration timer can be set for a minimum of 20 minutes to a maximum of 24 hours. The default value for the expiration timer upon system start-up is 60 minutes. If the timer expires before it is restarted, the exception list entry is removed. The expiration timer allows the **EAGLE** to save resources if the exception list entry is sitting idle for a specified period of time.

An exception list entry can be created for three distinct set of conditions.

1. The first set of conditions creates exception list entries based on the status of the route (allowed, restricted, or prohibited) and are marked as "exception list due to routing."
2. The **EAGLE** creates an exception list entry to maintain the congestion status of a non-provisioned, cluster routed destination point code. These entries are marked "exception list due to congestion."

3. The **EAGLE** also creates an exception list to prohibit routing to a member of a cluster when circular routing to that member is detected. These exception list entries are marked “exception list due to circular routing.”

An exception list entry for a particular cluster can be removed from the exception list when the following conditions are met:

1. The status of all routes to the specified point code changes to a status that is less or equally restrictive than corresponding status of cluster’s routes. This can happen for two reasons.
 - a. A `dact-rstst` command was issued. The `dact-rstst` command changes the route’s status to allowed.
 - b. A network management message (**TFA** or **TFR**) was received indicating the new status of the route to the specified point code.
2. The expiration timer for the exception list entry expires.
3. When a `chg-dstn` command is issued and changes the **ELEI** to `yes` for the cluster; the **EAGLE** removes all exception list entries created for that cluster.
4. The `chg-stpopts` command was issued with the `mtpxlet` parameter and the new value for the `mtpxlet` parameter was smaller than the original value. This command can change allocation of routing table entries for exception lists. If the size of the exception list is reduced and the number of entries in the exception list is now greater than the new value of the `mtpxlet` parameter, the **EAGLE** will remove excess exception list entries at random.
5. When a user allows a circular routed “exception list due to circular routing” entry after fixing the problem. The `rst-dstn` command is used to allow the routing.
6. When congestion abates for an “exception list due to routing” entry.

Cluster Routing

When the **EAGLE** receives an **MSU** to route, the routing function looks for the **MSUs** destination point code as a full point code entry in the routing table. If found, the full point code entry is used to find the corresponding routeset and the outgoing route. If a full point code entry is not found, the routing function uses the destination point code’s network and cluster values to find a cluster entry to which a destination point code belongs. If found, the cluster entry is used to find the corresponding routeset and the outgoing route. If neither a full point code entry or cluster point code entry is found, the **EAGLE** generates **UAM 1004**, “**MTP rcvd unknown DPC.**”

Compatibility with Non-Cluster Routing STPs

It is possible that not all **STPs** in the network that the **EAGLE** is operating in are cluster routing **STPs**. In such a situation, those **STPs** not doing cluster routing will interpret **TCx** messages and apply them to each individual point code belonging to the concerned cluster. This may cause an inconsistency in the status records for exception listed point codes in different **STPs**. In order to avoid this situation, the **EAGLE** takes the following steps:

1. After broadcasting a **TCR** message for a cluster, the **EAGLE** enables **TFPs** for the cluster’s exception listed prohibited member point codes by stopping the level 3 T8 timer. This allows **TFPs** to be sent for prohibited members immediately after a **TCR** is broadcast.
2. After broadcasting a **TCA** message for a cluster, the **EAGLE** enables a one-time **TFR** for the cluster’s exception listed restricted member point codes by stopping the level 3 T18 timer and enables the **TFPs** for the cluster’s exception listed (prohibited) member point

codes by stopping the level 3 T8 timer. This allows **TFPs** to be sent for prohibited members and **TFRs** for restricted members immediately after a **TCA** is broadcast.

Compatibility with the ITU Network and X.25 Gateway

ITU SS7 networks do not use the concept of clusters of point codes and cluster network management messages. The **EAGLE** does not generate **TCx** messages towards **ITU** nodes. The **EAGLE** does not send **TCx** messages to adjacent **ITU** point codes during the broadcast phase of **TCx** messages when the **EAGLE** is acting as an **STP** between an **ITU** network and an **ANSI** network. It is possible that messages may be lost in such a case. In order to reduce message loss and quickly notify the sending **ITU** node about the status, the **EAGLE** enables **TFPs** or **TFRs** immediately (with the level 3 T8 or T18 timers stopped) and relies on the **TFPs** or **TFRs** to convey the status information.

While sending response method network management messages in response to a received **MSU**, the **EAGLE** checks the **MSU**'s originating point code. If the **MSU**'s originating point code is an **ITU** point code, a **TFx** message is returned.

Cluster entries can only be provisioned as **ANSI** destination point codes. **Cluster** entries cannot be provisioned for **ITU** international or **ITU** national destination point codes. The **ANSI** alias point code for an **ITU** international or **ITU** national destination point code must be a full point code. **Cluster** routing is not supported for X.25 destinations. X.25 destinations and any alias point codes used for X.25 destinations must be full point code entries.

Cluster Management When the Cluster Routing Feature is Turned Off

Cluster routing is an optional feature and can be turned on with the `chg-feat:crmd=on` command. Once this feature is turned on, it cannot be turned off. If this feature is turned off, the **EAGLE** does not send any cluster management messages or allow cluster destination point codes to be added to the destination point code table. The **EAGLE** is capable of processing incoming cluster management messages even though the feature is turned off. When a cluster management message is received, the **EAGLE** treats this message as though network management messages were received for each full point code, configured in the destination point code table, belonging to that cluster.

2.82 Command Class Management (Release 29.0)

Description

The **Command Class** Management feature allows the user to place **EAGLE** commands into 32 new configurable command classes. The craftsman can provision any of these configurable command classes to contain any of the **EAGLE** commands. The command classes can then be assigned to a user and/or terminal, thus allowing the user or terminal the privilege of executing any command in the class. This allows users and terminals to fully configure custom command classes. This capability is controlled via a feature access key.

 **Note:**

The result is each user/terminal will have access to a set of commands tailored to a specific need. The new configurable command classes are in addition to the existing non-configurable command classes. The current basic and non-configurable command classes will remain.

Refer to the *Commands Manual* for current detailed information on this feature.

Hardware Requirements

No new hardware is needed to support this feature.

Limitations

There is a limitation on the feature's operation regarding the use of the `ENT-USER`, `CHG-USER`, `CHG-SECU-TRM` and `CHG-CMD` commands. These commands can assign a maximum of eight command classes per command execution. However, subsequent command executions can be used to readily assign the full number of required configurable command classes.

2.83 Command Output Changes (Release 22.0)

The method of displaying whether the `copy=yes` or `redirect=yes` parameters have been specified for a given screening entry in the gateway screening retrieve commands has been changed. The heading of the **NSR** field of the output has been changed to **NSR/ACT** to display either the next screening reference name (**NSR**) or the next action that is to be performed (**ACT**). The same field can be used to display both of these items, because in previous releases, the **NSR** field is blank when the `copy=yes` and `redirect=yes` parameters have been specified. These parameters can only be specified when the **NSFI** is set to `stop` and the `nsr` parameter cannot be specified.

If the **NSFI** of the screen is not `stop` or `fail`, the **NSR/ACT** field displays the name of the next screening table to be used in the gateway screening process.

When **NSFI** of the screen is `stop`, the **NSR/ACT** field contains the following entries.

- -, - — if neither the `copy=yes` or `redirect=yes` parameters have been specified. This entry is also displayed if the **NSFI** of the screen is `fail` (only with the `rtrv-scr-blkdpc` and `rtrv-scr-blkopc` commands)
- C, - — if only the `copy=yes` parameter has been specified
- -, R — if only the `redirect=yes` parameter has been specified
- C, R — if both the `copy=yes` and `redirect=yes` parameters have been specified

Refer to the *Commands Manual* for current command information..

The outputs of these commands have been changed to this new format.

- `rtrv-scr-opc`
- `rtrv-scr-dpc`
- `rtrv-scr-blkdpc`

- `rtrv-scr-blkopc`
- `rtrv-scr-destfld`
- `rtrv-scr-sio`
- `rtrv-scr-cgpa`
- `rtrv-scr-cdpa`
- `rtrv-scr-aftpc`
- `rtrv-scr-tt`
- `rtrv-scrset`

2.84 Command to perform migration of IPLIM to IPSG (Release 42.0)

The Command to perform migration of IPLIM to IPSG feature introduces the `chg-card` command to automate the migration from an IPLIM configuration to an IPSG configuration.



Note:

If changing the configuration from IPLIM to IPSG exceeds the Transactions per Second (TPS) limits of the card or system, then the command is rejected.

2.84.1 Hardware Requirements

Only E5-ENET hardware configured as IPLIM cards can be changed to IPSG using the `chg-card` command

2.85 Configurable SCTP Heartbeat Timer (Release 46.0)

The Sctp HeartBeat Timer is configurable on a per association basis. The timer value is configurable from 500 milliseconds to 3000 milliseconds.

2.86 Configurable Timer for link NO-DATA Condition (Release 37.7, 39.0)

The Configurable Timer for link NO-DATA Condition core enhancement provides a configurable timer to measure the time that must pass with no transmissions on a link before a link or terminal equipment failure is declared and changeover procedures are initiated. This timer is referred to as a nodata timer.

The nodata timer is used by low speed links on the HC-MIM, E1/T1 MIM, and MPL cards.

2.87 Configuring the Frequency of RST Messages on Low Priority Routes (Release 22.0)

This feature allows the configuring of a timer to specify the frequency of signaling-route-set-test messages for routes of lower priority than the current route.

In earlier releases, the routeset test messages were sent for every route to every destination for a period of time equal to the value of the level 3 timer T10. With this feature, the **EAGLE** only sends the routeset test messages for routes of equal or higher priority than the current route.

Parameters

To send routeset test messages for lower priority routes, new parameters (`mtplprst` and `mtpt10alt`) have been added to the `chg-stpopts` command to turn this capability on and to set the timer to control the frequency that the routeset test messages are sent.

`mtplprst` — turns on or off the routeset test message for lower priority routes capability. The values for this parameter is `yes` or `no`. The default value for this parameter is `yes`.

`mtpt10alt` —the timer to control the frequency at which the routeset test messages are sent. The values for this parameter are from 30 to 10,000 milliseconds. The default value for this parameter is equal to the value of the level 3 T10 timer.

When the `mtplprst=no` parameter is specified with the `chg-stpopts` command, the **EAGLE** does not send routeset test messages for the lower priority routes. When the `mtplprst=yes` parameter is specified, the **EAGLE** sends routeset test messages at intervals specified by the value of the `mtpt10alt` parameter.

The network example shown in Figure *Route Set Test Example* shows how this feature works. The following table shows the priorities of the routesets to destination X.

Table 2-20 Routeset Priorities

Routesets to Destination X	Cost
Ls1 (high priority route)	10
Ls2 (current route)	20
Ls3 (low priority route)	30

Destination X is currently accessible from **STP A** using route Ls2. **STP C** and **STP B** have sent **TFP** messages for destination X to **STP A**. **STP C** is on higher priority route than the current route while **STP B** is on lower priority route than the current route. By default, the **EAGLE** polls **STPs B** and **C** by sending **RSP** messages for destination X at intervals defined by the level 3 timer T10. The polling frequency to **STP B** can be changed by changing low priority route set test time interval with the `mtpt10alt` parameter of the `chg-stpopts` command and setting it to a value greater than the value of the level 3 timer T10. **RSP** messages for destination X are sent to **STP C** at intervals defined by the level 3 timer T10 and **RSP** message for destination X are sent to **STP B** at intervals defined by the `mtpt10alt` parameter.

Figure 2-13 Route Set Test Example

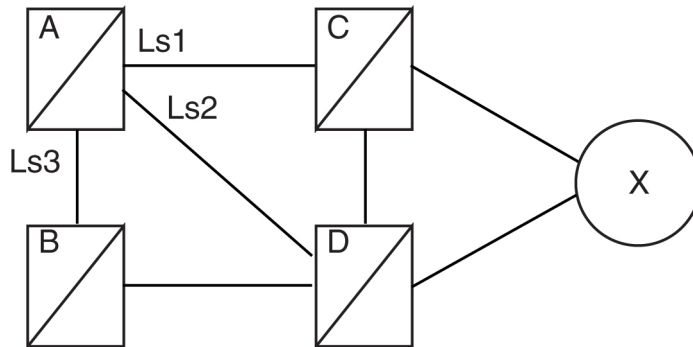

The level 3 T10 timer and `mtpt10alt` parameter of the `chg-stpopts` command are configured independently. The **EAGLE** requires that the value of the `mtpt10alt` parameter is greater than or equal to the value of the level 3 T10 timer. If the value of the level 3 T10 timer is increased to a value greater than the current value of the `mtpt10alt` parameter, the value of the `mtpt10alt` parameter is adjusted to be equal to the new value of the level 3 T10 timer and the following message is displayed in the scroll area of the terminal.

MTP T10alt Timer in STP Options Table adjusted to correspond with T10 Timer.

If the value of the level 3 T10 timer is decreased, the value of the `mtpt10alt` parameter is not adjusted.

Any changes in the values of the level 3 T10 timer and the `mtpt10alt` parameter of the `chg-stpopts` command take affect only after these timers have expired.

2.88 Configuring the Unauthorized Use Warning Message (Release 22.0)

Currently, the **EAGLE** displays the following message immediately after successfully logging into the **EAGLE**.

```
NOTICE: This is a private computer system.  
Unauthorized access or use may lead to prosecution.
```

In Release 22.0, the user can now configure their own warning message that follows a successful login. The message can contain up to 20 lines of text with each line of text containing up to 70 characters.

When a login attempt is successful, the user sees the warning message (0 - 20 lines) and then 2 lines of login history information. The administrator can configure the warning message so that it and the login history information will not all fit into the scroll area of the **EAGLE** terminal. The user can use scroll area locking (F8) key so the login warning message can be read before it scrolls out of view.

 **Note:**

When the **EAGLE** is delivered to the user, the database will contain the following login warning message. This complies with the suggested Bellcore default values.

```
NOTICE: This is a private computer system. Unauthorized access or
use may lead to prosecution.
```

The `chg-secu-dflt` and `rtrv-secu-dflt` commands have been modified to configure this warning message.

Two parameters have been added to the `chg-secu-dflt` command to configure the login warning message, `wrnln` and `wrntx`.

The `wrnln` parameter specifies the line number of the login warning message that is being changed. The values for this parameter are from 1 to 20.

The `wrntx` parameter specifies the text for the line number of the login warning message. The text line can contain up to 70 alphanumeric characters and must be enclosed in quotes (""). A text line with no characters can be specified with this text string, "". This prevents the text line from being displayed in the login warning message. A blank line is specified with this text string, "".

The following is an example of how the login warning message can be configured.

Input Examples:

```
CHG-SECU-
DFLT:WRNLN=1:WRNTX="*****"
CHG-SECU-DFLT:WRNLN=2:WRNTX="* NOTICE: This is a private computer
system. * "
CHG-SECU-DFLT:WRNLN=3:WRNTX="* UNAUTHORIZED ACCESS OR USE WILL BE
PROSECUTED * "
CHG-SECU-
DFLT:WRNLN=4:WRNTX="* "
CHG-SECU-
DFLT:WRNLN=5:WRNTX="* "
CHG-SECU-DFLT:WRNLN=6:WRNTX="* 06/07/97 Notice!!! EAGLE will be upgraded
between * "
CHG-SECU-DFLT:WRNLN=7:WRNTX="* the hours of 2am-3am on
06/15/97. * "
CHG-SECU-
DFLT:WRNLN=8:WRNTX="* "
CHG-SECU-
DFLT:WRNLN=9:WRNTX="* "
CHG-SECU-
DFLT:WRNLN=10:WRNTX="*****"
"
CHG-SECU-DFLT:WRNLN=11:WRNTX=" "
CHG-SECU-DFLT:WRNLN=12:WRNTX=""
CHG-SECU-DFLT:WRNLN=13:WRNTX=""
CHG-SECU-DFLT:WRNLN=14:WRNTX=""
```

```

CHG-SECU-DFLT:WRNLN=15:WRNTX=""
CHG-SECU-DFLT:WRNLN=16:WRNTX=""
CHG-SECU-DFLT:WRNLN=17:WRNTX=""
CHG-SECU-DFLT:WRNLN=18:WRNTX=""
CHG-SECU-DFLT:WRNLN=19:WRNTX=""
CHG-SECU-DFLT:WRNLN=20:WRNTX=""

```

The following is an example of what this example login warning message would look like after a successful login attempt.

Output Example:

```

*****
*NOTICE: This is a private computer system.
**UNAUTHORIZED ACCESS OR USE WILL BE PROSECUTED
**
**
**06/07/97 Notice!!! EAGLE will be upgraded between
**the hours of 2am-3am on 06/15/97
**
**
*****
0 LOGIN failures since last successful LOGIN
Last successful LOGIN was on port 3 on 97-06-07 @ 12:12:35

```

The parameter `msg` (with the values `yes` or `no`) has been added to the `rtrv-secu-dflt` command to display the text of each line of the login warning message. If the `msg=yes` parameter is specified, the security defaults for user **IDs** and passwords and the 20 lines of text for the login warning message are displayed. If the `msg=no` parameter (the default value for this parameter) is specified, the security defaults for user **IDs** and passwords are displayed, but the login warning message text lines are not displayed. The following is an example of the `rtrv-secu-dflt:msg=yes` command output.

Output Example:

```

RLGHNCXA03W 97-06-07 16:02:05 EDT Rel 22.0.0
SECURITY DEFAULTS
-----
PAGE          60
UOUT          90
MULTLOG       NO
MINLEN        8
ALPHA         1
NUM           1
NC            1
WARNING MESSAGE
-----
1:"*****"
2:"* NOTICE: This is a private computer system.   *"
3:"* UNAUTHORIZED ACCESS OR USE WILL BE PROSECUTED  *"

```

```

4:"*                                     *"
5:"*                                     *"
6:"* 06/07/97 Notice!!! EAGLE will be upgraded between *"
7:"*                               the hours of 2am-3am on 06/15/97.  *"
8:"*                                     *"
9:"*                                     *"
10:"*****"
11:" "
12:""
13:""
14:""
15:""
16:""
17:""
18:""
19:""
20:""

```

2.89 Congestion Abatement Reporting (Release 21.0)

When a signaling link's congestion level changes, these changes are reported to the user as **UAMs** (unsolicited alarm messages), whether the congestion level increases or decreases. The **UAMs** show how the signaling link congestion level has changed. The following table shows the changes in the signaling link congestion level changes and the **UAM** that reports these changes. No alarms are associated with these **UAMs**.

Table 2-21 Signaling Link Congestion Messages

From Level	To Level	Output Messages	UAM
0	1	REPT-LINK-CGST: congestion level 0 to 1	0264
0	2	REPT-LINK-CGST: congestion level 0 to 1	0264
		REPT-LINK-CGST: congestion level 1 to 2	0265
0	3	REPT-LINK-CGST: congestion level 0 to 1	0264
		REPT-LINK-CGST: congestion level 1 to 2	0265
		REPT-LINK-CGST: congestion level 2 to 3	0266
1	0	RCVRY-LINK-CGST: congestion has cleared	0269
1	2	REPT-LINK-CGST: congestion level 1 to 2	0265
1	3	REPT-LINK-CGST: congestion level 1 to 2	0265
		REPT-LINK-CGST: congestion level 2 to 3	0266
2	0	RCVRY-LINK-CGST: congestion level 2 to 1	0268
		RCVRY-LINK-CGST: congestion has cleared	0269
2	1	RCVRY-LINK-CGST: congestion level 2 to 1	0268
2	3	REPT-LINK-CGST: congestion level 2 to 3	0266
3	0	REPT-LINK-CGST: congestion level 3 to 2	0267
		RCVRY-LINK-CGST: congestion level 2 to 1	0268
		RCVRY-LINK-CGST: congestion has cleared	0269
3	1	REPT-LINK-CGST: congestion level 3 to 2	0267
		RCVRY-LINK-CGST: congestion level 2 to 1	0268

Table 2-21 (Cont.) Signaling Link Congestion Messages

From Level	To Level	Output Messages	UAM
3	2	REPT-LINK-CGST: congestion level 3 to 2	0267

2.90 Consistent Command Response Conversion (Releases 22.0, 24.0)

The consistent Command Response Conversion feature enables **GUI** software to read a consistent command response from the **EAGLE STP** and display the information in a suitable format and language on Keyboard Send/Receive (**KSR**)-mode-provisioned ports. This requirement fulfills the **GUI**'s requirement to know when an **EAGLE**-initiated command is completed.

Command Execution

To ensure reliability and uniqueness of pattern, a sequence of eight End of Transmission (**EOT**) characters (h'04) is used to indicate that the entered command has completed. These End of Transmission characters are not visible on the terminal display. This sequence, in most cases, means that all associated data output in response to the command entered has been displayed. Exceptions in which data output between the start of a command and the receipt of the **EOTs** may differ from the norm include the following:

- Commands with delayed completion that allow other output to be displayed (for example, `copy-disk` and `format-disk`).
- Commands that report completion but actually continue displaying results for some amount of time (for example, `rept-meas`).
- Commands entered in midstream of unsolicited output via Ctrl-A. For example:

Output Example for Release 22.2:

```
lnpstp 97-12-30 18:02:07 EST Rel 22.2.0.0
Error writing table 206:  on standby TDM (A);
>set-date:date=971201
Command Accepted - Processing
      DMS0002:table not found on disk[H'290e].
;
  lnpstp 97-12-30 18:02:07 EST Rel 220.18.0.0  set-
date:date=971201  Command entered at terminal #5.
;
  lnpstp 97-12-30 18:02:07 EST Rel 220.18.0.0  Date set complete. ;
(Response Ended - string of EOTs here)
```

Output Example for Release 24.0:

```
RLGHNCXA03W 99-01-07 00:57:31 EST Rel 24.0.0
Error writing table 206:
```

```
    on standby TDM (A);
>set-date:date=990301
Command Accepted - Processing
    DMS0002:table not found on disk[H'290e].
;
RLGHNCXA03W 99-01-07 00:57:31 EST Rel 24.0.0
set-date:date=990301
Command entered at terminal #5.
;
RLGHNCXA03W 99-03-01 00:57:31 EST Rel 24.0.0
Date set complete.
;(Response Ended - string of EOTs here
```

2.91 Core Software Version Updates (EPAP 16.0)

The underlying operating system for EPAP is updated to CentOS Version 5.10, and the underlying database is updated to MySQL Version 5.6.

2.92 Cost Factor on Routing (Release 20.0)

This feature allows the assignment of a weighting factor to a route. The weighting factor is then used by **MTP** routing to determine which is the primary route, and which are the alternate routes. By using this feature, multiple routes may be assigned to a destination, with a primary route selected for all routing unless congestion or some other condition should be encountered, at which point one of the alternate routes would be chosen.

Each routeset (which is a combination of routes) may be assigned six routes, with each route assigned a different cost factor. The range for cost factors is 0 to 99, with 99 being the least favorable route (highest cost).

Combined linksets may be assigned the same cost factor, allowing equal load sharing over the two linksets. Alternate combined linksets may also be created by assigning a higher cost factor to subsequent linksets.

2.93 CRP for SRIs without HomeRN (Release 42.0)

The MNP Circular Route Prevention feature (**CRP**) is enhanced to allow CRP based on the translation type (**TT**) to be performed for SRI messages when a Home Routing Number (**HomeRN**) is not present.

SRI Messages must meet the following criteria to be eligible for TT-based CRP:

- The message is selected for G-Port or IS41 GSM Migration processing.
- The message is not identified as G-Port SRI Query for Prepaid.
- The message is not MTP-routed (the CdPA is Route-on-GT).
- The SCCP CdPA TT matches the provisioned TT.
- The TCAP Package type is ITU Begin.
- The OpCode is an SRI (hexadecimal 16).
- The Optimal Routing Interrogation Parameter (Tag = 0x04) is not present.
- The MSISDN is not assigned to the subscriber's network provider.

2.93.1 Feature Control Requirements

The MNP Circular Route Prevention feature (Part Number 893-0070-01) must be turned on before TT-based CRP processing can be provisioned. The MNP CRP feature cannot be turned off if this CRP processing is provisioned.

2.94 CSPC Increase in Groups (Release 34.0)

The maximum number of point codes that can be provisioned in a Concerned Signaling Point Code (CSPC) group is increased from 32 to 96.

2.95 Customer Definable Alarms (Release 20.0)

This feature allows the user to connect up to 10 external devices to the **EAGLE** for alarm reporting. These are defined in the **EAGLE** database as customer defined troubles. These external devices are monitored and any changes in the state of these devices is reported to the user as an unsolicited alarm message (**UAM**). Two of these **UAMs** generate critical alarms, two **UAMs** generate major alarms, six **UAMs** generate minor alarms. The following table lists the **UAM**, the alarm level, and the trouble **ID**.

Table 2-22 Customer Definable Troubles Alarm Levels

Customer Trouble ID	Alarm Detected UAM	Alarm Clearing UAM	Customer Trouble ID	Alarm Detected UAM	Alarm Clearing UAM
1	Reserved	N/A	9	Reserved	N/A
2	Reserved	N/A	10	Reserved	N/A
3	0058 - Critical	0062 - Normal	11	0060 - Minor	0062 - Normal
4	0058 - Critical	0062 - Normal	12	0060 - Minor	0062 - Normal
5	Reserved	N/A	13	0060 - Minor	0062 - Normal
6	Reserved	N/A	14	0060 - Minor	0062 - Normal
7	0059 - Major	0062 - Normal	15	0060 - Minor	0062 - Normal
8	0059 - Major	0062 - Normal	16	0060 - Minor	0062 - Normal

The following messages are examples of these **UAMs**.

UAMs

```

ralncstp01 95-05-12 12:14:59 EST Rel 20.0.0
*C 4054.0058 *C CDT 4 Critical Customer Trouble
detected
ralncstp01 95-05-12 12:14:59 EST Rel 20.0.0
** 4055.0059 ** CDT 8 Major Customer Trouble
detected
ralncstp01 95-05-12 12:14:59 EST Rel 20.0.0
* 4056.0060 * CDT 11 Minor Customer Trouble
detected

```

```
ralncstp01 95-05-12 12:14:59 EST Rel 20.0.0
4058.0062   CDT     9           Customer Trouble cleared
```

The status of these **UAMs** are displayed with the `rept-stat-cdt` command.

When the alarm condition that displayed these **UAMs** is cleared, **UAM** number 0062 is displayed.

2.96 CutAndPaste parameter in Connect response to INP IDP Query (Release 42.0)

The INP feature is enhanced to allow the *CutAndPaste* parameter to be included in the Connect response to an INP IDP query. This parameter provides the number of digits that the originating node of the query should discard from the CdPN digit string that the node is holding. Any digits remaining after the discard are pasted at the end of the DRA digits included in the Connect response. The query originating node uses this digit combination to construct a new routing number.

The *CutAndPaste* parameter consists of 3 bytes (*tag*, *length*, and *value*). The *value* field is the length of the incoming CdPN digit string (incoming DN) received in the INP IDP query. Therefore, the query originating node discards the entire CdPN digit string and uses the DRA digits as the routing digits.

If the *CutAndPaste* functionality is provisioned as ON, then the *CutAndPaste* parameter is included in the Connect response. Otherwise, the parameter is excluded. If the INPOPTS:DRA setting has a DN component, then the value field of the *CutAndPaste* parameter is the length of the incoming CdPN digit string (incoming DN) received in the IDP query. This informs the querying node to discard all stored digits, because the DN is supplied in the Connect response. If the INPOPTS:DRA setting does not have a DN component, then the value is zero. This informs the querying node to use all stored digits, because none are present in the DRA.

2.96.1 Feature Control Requirements

The INP feature (Part Number 893-0179-01) must be enabled before the CutAndPaste functionality can be provisioned.

2.97 Database Integrity Enhancements (Release 20.0)

With this feature, the system audits the actual data in each module, provides checksum information, and verifies the checksum information against the original checksum that was downloaded to the module.

2.98 Database Management Command Functions (Release 20.0)

Description

In this feature, the database management commands are used to perform the following operations.

- Backing up the database to the fixed disk and to the removable cartridge
- Restoring the database from the fixed disk and from the removable cartridge
- Copying the approved **GPLs** from the active fixed disk onto a removable cartridge
- Copying the measurements data from the fixed disk onto a removable cartridge
- Displaying the directories and files on either the fixed disks or the removable cartridge

These five operations are discussed separately, below.

Backup

This command makes a backup copy of the administered data that can later be used to restore the data. The backup is made onto both the fixed disks or onto the removable cartridge according to a parameter of the command. The original data is taken from the current partition on the fixed disk.

If the backup is made to the fixed disks, the current partition on a fixed disk is copied to the backup partition on the same fixed disk.

If the backup is made to the removable cartridge, it is taken from the current partition of the fixed disk of the active **MASP** and copied to the removable cartridge. There is only one data partition on the removable cartridge, and this is defined to be the backup partition.

Restore

This command allows the user to bring back onto the fixed disk a set of known good tables, which had been previously backed-up on a disk (either fixed or removable). This command only restores the administered data tables, not the **GPLs** or measurement tables.

When the restore is from the fixed disk, the backup partition is copied into the current partition.

When the restore is done from the removable cartridge, the backup partition on the removable cartridge is copied onto the current partition on the fixed disk. This command modifies the data tables on the fixed disks of both the active and standby **MASPs**.

When the restore is from the removable cartridge, the tables are copied to the fixed disks on both **TDMs**. It does not propagate any data changes to the **SCCP** cards, **LIMs**, and so forth. To propagate the changes resulting from the restored database, the **EAGLE** must be reinitialized.

Copy GPL

This command copies the set of approved **GPLs** from the active fixed disk on the **TDM** onto a removable cartridge. This is typically done after the installation of a new **GPL** on the system, when the **GPLs** have been approved, and will allow the user to keep one removable cartridge with a copy of all the approved **GPLs** in use on the system.

These **GPLs** may be brought back into the system from the removable cartridge using change **GPL** commands if there is a need to bring a system back to a prior state, or if a spare fixed disk needs to be brought up to date.

Copy Measurements

When there is a need to perform offline analysis of the raw measurements data, this command copies that data onto the removable cartridge. The data is copied from the active fixed disk on the **TDM** to the removable cartridge.

Measurements collection is not allowed to continue while this command is copying the tables, since this may result in data from one collection period spilling over into data from another collection period. Measurements cannot be copied if measurement collection is turned on. Measurement collection must be turned off if you wish to copy the measurements tables.

Since there are two formats for removable cartridges, and only one of these is valid for measurements, the command will give a clear error message if the wrong type of removable cartridge is mounted in the drive.

Disk Directory

This command displays the directory on the specified disk. It can be used to display the creation date for each file or selected files and to verify that the correct version of files are on the fixed disks or the removable cartridge.



Note:

Wildcards "*" and "?" can be used for filename matching. The "*" will match any number of characters, and any "?" will match any single character.

2.99 Database Transport Access (DTA) (Release 20.0)

This feature interconnects the X.25 and **SS7** network protocols. This connection enables the interworking of several telephony and financial database application protocols carried within the X.25 and **SS7** messages.

Refer to the **Database Administration Manual - Features** for current details of this feature.

2.100 DEIR on SLIC Network Redundancy Enhancement (Release 46.4)

This feature implements SCTP Multi-homing to provide network redundancy for the EAGLE Diameter EIR feature executing on SLIC. SCTP multi-homing provides a level of fault tolerance against network failures by using alternate paths through the IP network between two endpoints.

Prior to EAGLE 46.4, the Diameter EIR application architecture only used a single network connection to the ExAP and a single connection to the client. [Figure 2-14](#) shows the SLIC Network Redundancy model introduced in EAGLE 46.4:

Figure 2-14 Network Redundancy Model Using SLIC

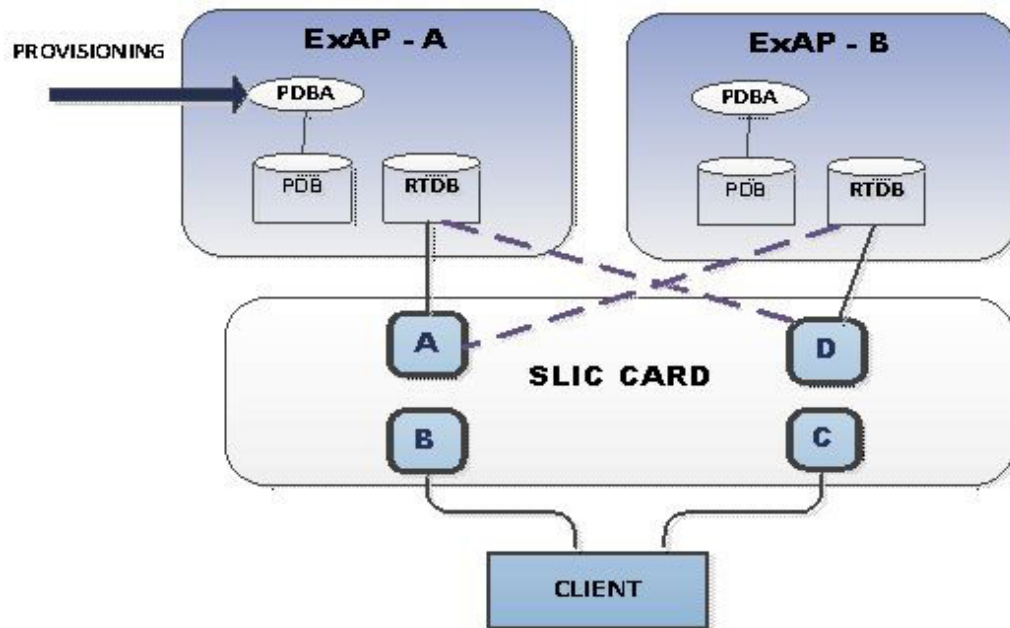

2.100.1 Hardware

The EAGLE supports the Diameter EIR redundancy enhancement on the SLIC card.

2.101 Delay Vs. Throughput (IP⁷ Release 5.0)

Description

This feature provides some level of user control over the **TCP** retransmission behavior that an individual **TALI** socket exhibits. Several aspects of **TCP** retransmissions need to be introduced in order to understand how this delay versus throughput feature will work.

As far as this feature is concerned, there are three primary aspects of **TCP** retransmissions that need to be understood.

- Retransmission timer
- Retransmission mode
- Congestion window

Retransmission Timer

Conceptually, the **TCP** retransmission timer is a timer that is started when a **TCP** data segment is sent on a socket. The **TCP** data segment is encapsulated in an **IP** packet (we will refer to this data segment being sent as a **TCP** packet, even though **TCP** is a byte oriented transport layer that does not typically send 'packets'). If an acknowledgement for the **TCP** packet arrives before the timer expires, the timer is stopped. If the timer expires before an acknowledgement arrives, the original packet is assumed to be lost/corrupted and a retransmission of that packet occurs.

In practice, most **TCP** implementations do not start a separate timer for each packet, rather an internal timer expiration occurs at a fixed interval and upon each internal timer expiration the data related to outstanding transmit packets without acknowledgements is analyzed to determine which retransmissions occur. It may take multiple expirations of the internal timer until the overall timeout exceeds the retransmission timer. Therefore the actual time delay for each initial retransmission falls within a range determined by the frequency of the fixed timer expiration. For example, if a 50 millisecond internal timer is used, and it takes three expirations of the internal timer until a retransmission occurs, the actual timeout used varies from 101 milliseconds to 150 milliseconds.

In this document, the term 'internal retx timer' refers to the internal **TCP** timer that expires at a fixed interval regardless of how many transmit packets are outstanding. Upon each internal retx timer expiration, retransmissions are analyzed and possibly sent.

In this document, the term 'initial retransmission timeout' refers to the minimum amount of time that passes from when a packet is first transmitted until the initial retransmission occurs. It is important to note that the timeout refers to the minimum time before retransmission (not the maximum or average).

In this document, the term 'retransmission timeout' refers to the minimum amount of time that passes until the next retransmission occurs. The pending retransmission may or may not be the first retransmission based on the condition being described. The 'retransmission timeout' always refers to the current timeout.

In this document, the terms 'previous retransmission timeout' and 'next retransmission timeout' refer to the minimum timeouts before and after the current retransmission timeout.

Retransmission Mode

The retransmission mode refers to how the timeout varies from previous to current to next retransmission timeout.

There are several modes discussed in this document.

- **BSD** mode refers to exponential growth of the timeout. Upon each timeout the next retransmission timeout is equal to 2 x the current retransmission timeout. Usually there is an upper limit on the exponential growth (exponential up to a threshold, then stays at the threshold).
- **FIXED** mode refers to a constant timeout that does not change as subsequent retransmissions of the same packet occurs.
- **MODIFIED** mode refers to a combination of the above two modes. One implementation of this mode may use a fixed mode for two out of every three consecutive retransmissions, shifting to the **BSD** mode on every third retransmit.

The following figure shows the relative spacing of timeouts for the three different retransmissions modes. Note that the spacing for **BSD** mode is incomplete due to its relatively long sequence

Figure 2-15 Spacing of Retransmissions in the Three Modes

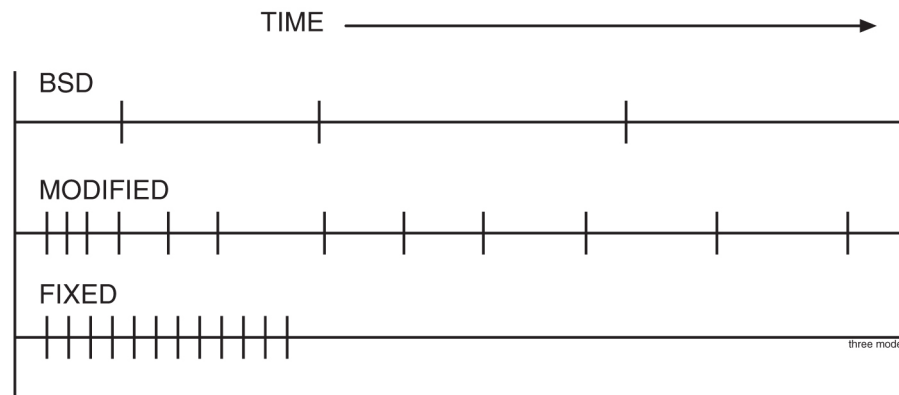

- The **TCP** protocol uses a sliding window to determine how much transmit data can be sent at one time, based on the minimum of the node's transmit window size and the far end's receive window size. The default **TCP** sliding window size is 8K bytes. Once 8K bytes of transmit data have been sent, with no acknowledgements received, the transmitter is prohibited from sending more until the far end sends acknowledgments for some portion of the window. The **TCP** window is said to slide when acknowledgments arrive, allowing packets with higher sequence numbers to be sent as packets with lower sequence numbers are acknowledged.
- Even though a particular socket within a **TCP** stack is configured for an 8K sliding window size, there are times when the **TCP** protocol does not take advantage of the entire 8K sliding window. One of these times is when retransmissions occur.
- When the **TCP** layer needs to retransmit one or more packets on a socket, the **TCP** protocol uses the minimum congestion window size rather than the **TCP** sliding window size to limit how much traffic can be sent until it must wait for acknowledgments. The minimum congestion window size is typically much less than the **TCP** sliding window size. As acknowledgments arrive from the far end after a retransmission event, the node slowly grows the congestion window up from the minimum congestion window to the size of the **TCP** sliding window.
- Another way of looking at this aspect of retransmission is to state that when a retransmission occurs, a transmitter intentionally lowers its own throughput until enough evidence from the far end arrives to assure the transmitter that the network is not congested. This phenomena is also referred to as congestion avoidance.

Socket Connection Dropped due to Retransmission Timeouts

- One other aspect of **TCP** retransmissions that should be mentioned is what happens when the same packet gets retransmitted over and over. When multiple retransmissions occur for a single packet, the **TCP** layer counts the number of retransmissions that is performed, and when this count gets too high the **TCP** socket is closed due to excessive retransmission timeouts. This shows up in the `netstat -p tcp` output in the 'connection dropped by rexmit timeout' row.
- In the **BSD TCP** stack, when a packet has been retransmitted 12 times, the socket is closed. Given the use of the exponential retransmit mode in standard **BSD**, the 12 retransmissions correspond to a time period of approximately 205.5 seconds where the packet was not able to sent/ack'd. (205.5 is based on 500 ms x 511, 511

is the sum of the `tcp_backoff[]` array which governs how the exponential backoff occurs and when the top threshold is reached).

- In the **IP⁷ SG** stack, when a packet has been retransmitted 12 times, the socket is closed. Given the use of fixed retransmission mode with a 125ms timer, the 12 retransmissions correspond to a time period of approximately 1.5 seconds where the packet was not able to be send/ack'd.

Behavior of Standard BSD Sockets

The following table summarizes the **TCP** retransmission characteristics of a standard **BSD** socket.

Table 2-23 BSD Socket Retransmission Characteristics

Characteristic	Setting or Behavior (not configurable, applies to all sockets)
initial retransmission timeout	500 milliseconds
tcp window size	8k
retransmission mode	exponential
minimum congestion window	2 x the maximum segment size
how does cong window grow	initially grows exponentially via 1 MSS per ack. past a certain threshold, the growth is linear up to the point where the window is fully open
socket dropped due to retransmission timeout	after approx 205.5 seconds
RTO	500 ms default, algorithm to “learn” RTO by averaging recent round trip times, with software imposed upper bound

BSD sockets are extremely tolerant of poor network conditions and continue to wait for longer and longer time periods before performing subsequent retransmissions. These characteristics are not very well suited for time sensitive data such as **SS7**.

Behavior of IP⁷ SG Release 4.0 IPLIMX & IPGWX Sockets

The following table summarizes the **IPLIMX** & **IPGWX** retransmission characteristics present in the **IP⁷ SG** Release 4.0 product.

Table 2-24 IPLIMX Socket Retransmission Characteristics on IP⁷ SG 4.0

Characteristic	Setting or Behavior (not configurable, applies to all sockets)
initial retransmission timeout	125 milliseconds
tcp window size	192k
retransmission mode	fixed
minimum congestion window	32k
how does cong window grow	grows exponentially via 1 MSS per ack up to the point where the window is fully open
socket dropped due to retransmission timeout	after approx 1.5 seconds

Table 2-24 (Cont.) IPLIMX Socket Retransmission Characteristics on IP⁷ SG 4.0

Characteristic	Setting or Behavior (not configurable, applies to all sockets)
RTO	fixed, no dynamic information about actual round-trip times used

IPLIMX & IPGWX sockets have been tuned to handle time sensitive data and expect network conditions with low **RTT** and few transmission errors. The configuration shown above is not tolerant of networks with **RTT** above a certain threshold (approximately 100ms) or with too many transmission errors. The 4.0 implementation does not expect packet loss due to congestion. The only loss that is expected is due to hardware and/or transmission errors, bad checksums, and so forth. The 4.0 implementation expects little or no congestion on the network, and does not react in a fair manner (with respect to congestion avoidance) when congestion does occur.

Behavior of IP⁷ SG Release 5.0 IPLIMX & IPGWX Sockets

The following table summarizes the **IPLIMX** and **IPGWX** retransmission characteristics that are available in the **IP⁷ SG Release 5.0** product.

Table 2-25 IPLIMX Socket Retransmission Characteristics on IP⁷ SG 5.0

Characteristic	Setting or Behavior (configurable on a per socket basis)
initial retransmission timeout	as low as 125 milliseconds, settable in 125ms increments
tcp window size	192k
retransmission mode	fixed bsd modified
minimum congestion window	32k
how does cong window grow	exponential when mode = fixed modified exponential followed by linear when mode = bsd
socket dropped due to retransmission timeout	varies from 1.5 to 205.5 seconds based on the mode and retransmission timeout configured
RTO	fixed, no dynamic information about actual round-trip times used

As seen in the tables above, the Delay vs. “Throughput for **TALI** Sockets” feature allows the end user to tune the retransmission characteristics of individual sockets. Sockets can be set so that they can function in a variety of network conditions (for example, **LAN** connection vs. a trans-Pacific **WAN** connection).

Upgrade Considerations

The addition of two new parameters in the entry (in the Socket Table) for each **TCP/IP** Socket necessitates the need for changes to the Upgrade Procedures for Engineering Release 37. These two new fields, Retransmission Mode and Round Trip Time Value, must be initialized to default values. The Retransmission Mode is initially set to “**FIXED**”, with the Round Trip Time set to 60 milliseconds. A third field, the Congestion Window Lower Limit must be set to a calculated value using the default Round Trip

Time (60 milliseconds). These fields must be set up for every assigned socket. The upgrade applies to both the **OAM** and Application copies of the Socket Table.

Limitations

The **TCP/IP** Protocol Stack timing mechanism has been modified by Tekelec software engineers. These changes enable the protocol to support **TCP** timers with resolutions as low as 125 milliseconds. It is not within the scope of the "Delay Vs. Throughput for **TALI** Sockets" feature to implement any other **TCP** timer resolutions than those currently supported. Each value entered as part of the Round Trip Time parameter is mapped to a corresponding Retransmission Timer, with a resolution of 125 milliseconds.

2.102 Digit Action to Delete Country Code when Present and Prefix with Database Entity (Release 44.0)

The Digit Action to delete country code if present and prefix database entity feature allows the DELCCPREFIX Digit Action to be applied to the Called Party Global Title Address (CdPA GTA) when the GTA has a National format as well as when the GTA has an International format.

When the option is configured and the GTA has an International format, the Country Code is deleted and the GTA is prefixed with the Entity Id. When the GTA has a National format, the GTA is prefixed with the Entity ID.

2.103 DigitAction Expansion (Releases 31.11, 34.0)

Description

G-Port and **G-Flex** allow the **SCCP CdPA GTA** field to be overwritten if **G-Port** determines the call should be relayed to its destination after a **PDB** lookup is performed.

G-Port and **G-Flex** support options that can be selected to overwrite or not to overwrite the **SCCP CdPA GTA** field. These options are defined by the DigitAction field of the **PDBI** Enter Network Entity command and Update Network Entity command. The user can also set these options to format the **SCCP** field before the **EAGLE** relays the message to the destination.

The rules for formatting the SCCP CdPA GTA field are based on the value specified in the DigitAction field. If digitaction = none, the EAGLE 5 ISS does not overwrite the SCCP CdPA GTA field. For all other values, the EAGLE 5 SAS formats the SCCP CdPA GTA field according to the value assigned to DigitAction field.

The following table provides samples of the format of the **SCCP CdPA GTA** field of an outgoing message using **RN/SP ID= 1404** and default country code=886.

Table 2-26 DigitAction Applications

DigitAction	Value in Incoming CdPA GTA	Value in Outgoing CdPA GTA
none	886944000213	886944000213 (no change is made)
prefix	886944000213	1404886944000213
replace	886944000213	1404
insert	886944000213	8861404944000213
delccprefix	886944000213	1404944000213

Table 2-26 (Cont.) DigitAction Applications

DigitAction	Value in Incoming CdPA GTA	Value in Outgoing CdPA GTA
delcc	886944000213	944000213
spare1	886944000213	is treated as "none"
spare2	886944000213	is treated as "none"

This feature expands the DigitAction field in **PDBI** and the **EPAP GUI** to support additional values "delcc," "delccprefix," "spare1," and "spare2." If the DigitAction value is "delccprefix," the **SCCP CdPA GTA** field of an outgoing message is formatted by prepending the **RN/SP ID** to the incoming **SCCP CdPA GTA** field and deleting the default country code if present. If the DigitAction value is "delcc," the **SCCP CdPA GTA** field of an outgoing message is the incoming **SCCP CdPA GTA** field without the default country code if present. The result of specifying the DigitAction field values "spare1" and "spare2" is the same as specifying the value "none."

Hardware Requirements

Refer to the hardware baseline.

2.104 Disallow Simultaneous Logins Sessions with the Same User ID (Release 21.0)

In Release 21.0, the **EAGLE** does not allow more than one login session to be active at any given time for a specific user **ID**. During `login` command processing, a check is made to see if the user **ID** is associated with any currently active login session, or is in the process of logging on to another port. If the user **ID** is found to be already in use on some other **EAGLE** terminal port, then the login is rejected and the error message (the duplicate login error message) is displayed.

```
E2750 Cmd Rej: UserID already logged on (or is logging on) another port
```

The following message is also displayed in the scroll area of the terminal that gives the terminal port (port yy) that the user (UserID xxxxxxxx) is already logged to.

```
Info: UserID xxxxxxxx is currently logged on to port yy.
```

The check for multiple login sessions is made after the user **ID** and password have been successfully validated and before any password aging or force password change checking is done. As a result, the following events can occur.

1. If the user specifies an invalid login or password, this message is displayed and the duplicate login error message is not displayed.

```
E2757 Cmd Rej: Invalid userID/password combination
```

1. If the user **ID** and password is valid, but the user's password requires changing, they do not see the messages or prompts to change the password. Instead, they see the duplicate login error message.

This feature can be disabled by specifying the `chg-secu-dflt` command with the `multlog=yes` parameter

2.105 Discard TFC Traffic (Release 34.0)

The `chg-ss7opts` command includes the `discardtfc` and `discardtfcn` parameters to enable and disable the discarding of TFC traffic. The `rtrv-ss7opts` command displays the current setting of the parameters.

2.106 Disk Coherency Tests (Release 20.0)

This feature checks that the information in the database contains the correct pointers. The system can determine whether an update to the database failed and whether the information in the database was corrupted.

2.107 Disk Copy Fixed to Fixed (Release 20.0)

This feature allows maintenance personnel to create a mirror image from the active **TDM** fixed disk drive to the standby **TDM** fixed disk drive. This is used when replacing or updating a **TDM**.

If more than one message is sent to the **EOAP** without the **LSMS** waiting for a response, the **LSMS** must manage retries and the sequencing of messages.

The **EOAP** must be configured locally with the **LSMS OSI-Address** information necessary for association establishment. The **EOAP** will initiate association connections with the **LSMS**.

2.108 Display Inhibited Alarms (Release 29.0)

Description

This feature enhances the `rept-stat-alm` report to show all the devices that are alarm-inhibited, at what level and duration they are inhibited, and their current alarm level, if any.

Use of the Display Parameter

- If **DISPLAY=INHB** is used, a plus sign (+) seen in the “**Alarm** Inhibit Report” (i.e. in the **CUR ALM LVL** column) indicates that the current alarm is not inhibited, because the level of the inhibit is less than the level of the alarm.
- Column description:
 - Device and element is listed first. Only devices that are alarm inhibited are shown.
 - Duration shows whether the device is alarm inhibited permanently or temporarily.
 - The “alm inh lev” shows the level in which devices are alarm inhibited. The `inh-alm` command defaults level to major. Devices cannot be alarm inhibited at a critical level unless the `stopt critalminh` is turned on.
 - The “current alm lev” shows the level of the current alarm on that device. “None” means there is no alarm currently on that device. If there is no alarm currently on that device, the Duration should show “Perm.”

Hardware Requirements

No new hardware is needed to support this feature.

2.109 Dual ExAP Configuration (Release 45.0)

The Dual ExAP Configuration feature allows one EAGLE to support both ELAP and EPAP in one node. EPAP and ELAP provide separate databases for various EAGLE features. Features such as G-Flex, G-Port, EIR, TIF use the EPAP database. Features such as LNP use the ELAP database. The features using the EPAP database and the ELAP database have been mutually exclusive. With the Dual ExAP Configuration feature, the EPAP-based features and ELAP-based features can be enabled and turned on simultaneously on the same EAGLE.

With the Dual ExAP Configuration feature, all Service Modules acquire a new attribute called *Data Type*:

- EPAP - a Service Module containing all data from EPAP, including both EPAP tables, DN & IMSI
- ELAP - a Service Module loaded with data from ELAP.
- GTT - a Service Module which is not loaded with data from ELAP or EPAP; loaded only with data from OAM.

A new option SCCOPTS:GTTDIST controls the distribution of GTT-only traffic with no Real Time Database (RTDB) or Range Indexed Database (RIDB) lookup required.

2.109.1 Feature Control Requirements

- FAK for Part Number 893-0405-01
- A temporary FAK cannot be used to enable the feature.
- The feature cannot be turned off after it has been turned on.
- Message Flow Control must be turned on before the Dual ExAP Configuration feature can be turned on.
- The E5-SM4G Throughput Capacity feature must be enabled before the Dual ExAP Configuration feature can be turned on.
- The feature cannot be turned on if a DSM, E1-ATM, E1T1MIM, LIM-ATM, or MPL card is equipped and running in the system.

2.109.2 Hardware

E5-SM4G or E5-SM8G-B cards must be running in the system before the Dual ExAP Configuration feature can be turned on.

If a DSM, E1-ATM, E1T1MIM, LIM-ATM, or MPL card is installed after the Dual ExAP Configuration feature is turned on, the card will auto-inhibit.

2.110 E1 Administration and Alarms (Release 26.3)

Description

Instead of a card having to be removed to change the configuration, each card can be configured using new commands and extensions to existing commands. This capability allows customers ease of configuring and updating their network using the **EAGLE**. Also, since the **DIP** switches are no longer required, they can be removed from future production **E1** appliques.



Note:

This feature is backward compatible with the **E1** hardware, with or without the **DIP** switches.

With the introduction of this feature, the administration of the **E1** will be done by **EAGLE** commands. Thus various **EAGLE** commands have been created or modified.

Currently **E1** cards are "provisioned" via dip switches on the **LIM** board. Although this method of provisioning is functional, customers desire to integrate the provisioning of **E1** functionality similar to other **LIM** cards, via software. This feature enhances the current 2-Port **E1** feature by allowing the customer to configure the **E1** hardware without using the **DIP** switches on the applique. This feature also provides support for **E1** Master Timing.

Description of E1 Operation within an EAGLE

The introduction of this feature brings complete product support for the **E1** line interface into the **EAGLE**, thereby concluding the **E1** effort begun during Release 22.2. Along with **V.35**, the **E1** interface is a primary interface used outside of North America. Thus, this large market base is a large market potential for an **EAGLE** with an **E1** interface.

The **E1** cards are provisioned and operate in a fashion very similar to the current **DS0/OCU/V.35** signaling links:

- **E1** cards and links must be configured in the **EAGLE** in a manner similar to how existing signaling links are configured. These configuration activities include entering cards, entering links, assigning links to link sets, and activating cards and links, in addition to entering **E1** parameters. Changes to existing **EAGLE** commands, and new **EAGLE** commands, to perform these configuration activities are required.
- Two new card types, '**LIME1**' and '**LIMCH**', are used to define the **E1** card and **Channel** cards, respectively, in the **EAGLE**.
- A set of **E1**-specific interface parameters must be maintained on a per-**E1** basis. These parameters include:
 - which **E1** port is used (either #1 or #2)
 - **CRC4**, **CAS/CCS**, **HDB3/AMI**, master/slave clocking options
 - signaling bits settings
- A set of **E1**-specific interface parameters must be maintained on a per-signaling link basis. These parameters include:
 - which **E1** card is the card dropping timeslots

- which timeslots are being used
- The current **E1** implementation provisions **E1** cards as either **DS0** or **OCU**, based on master/slave timing. This feature provisions the cards as **E1** or channel with either master or slave timing.
- **Building Integrated Timing System (BITS)** clock alarms must be supported when **E1** cards with master timing are provisioned in the **EAGLE**. Currently, this is the reason that **E1** cards are provisioned as **DS0** cards.

The **TST-SLK** command will continue to support local transceiver loopback using the **ISCC**, just like the **DS0/OCU/V.35** cards; no changes are necessary.

EAGLE Application Support for E1

Currently the **SS7** application software initializes the hardware completely based on **DIP** switch values. With the new **E1** Administration and Alarms feature allowing **E1** cards to be provisioned, the **SS7** application software needs to only initialize the hardware to a benign state until provisioning information is provided. This initial hardware state is similar to the other link interface module (**LIM**) cards' initial state.

Hardware Requirements

This feature is dependent upon the **EAGLE E1** hardware, consisting of the **LIM E1** backplane kit (P/N 890-1037-01), which allows connectivity between the **E1 LIM** card(s) and the corresponding **E1** channel card(s) (both P/N 870-1379-01).

Upgrade Considerations

- The system release containing the **E1** Administration and Alarms feature must be field-upgradable, with the **EAGLE** in an in-service mode.
- The new current and backup tables for **E1** link interface parameter values must be created.
- A new phase is needed in the upgrade procedure to update the database with **E1** information retrieved from the network cards after the network cards have been loaded with the latest **GPL**.
- Prior to collecting **E1** information, cards will be loaded with the latest **GPL** with data from the database, including link information. Cards containing existing **E1** links must load and bring up their **SS7** links using the **DIP** switches instead of downloaded **E1** data in this case.
- **Card** type field in the current and backup **IMTA** tables needs to be corrected from **DS0/OCU** based on information received from each card.
- **E1** parameter information needs to be updated in current and backup **E1LINK** tables.
- **E1** timeslot information needs to be updated in current and backup **LINK** and **XLINK** tables.
- Since upgrade must be able to be performed remotely, there must be an automated way to map the **E1/Channel** card relationship via some method such as far-end loopback detection.
- Since **TS0** and **TS16** (when **CAS** is enabled) may be assigned using the **DIP** switches, the upgrade must detect and report this condition. However, no change can be made to the timeslots.

Limitations

The **E1** Administration and Alarms feature has these limitations:

- The configuration of the various **E1**/channel cards via the **E1** backplane is not validated with the **E1** parameter set information.
- There is no verification that the **E1** and channel cards are connected to the **E1** backplane.

2.111 E1 ATM High Speed Link (Release 28.1) (IP⁷ Release 6.0)

Description

International customers desire increased signaling bandwidth by utilizing **Asynchronous Transfer Mode (ATM)**. This capability requires **EAGLE** software to support **ATM**, as well as some hardware modifications to the existing **LIM-ATM** card that currently supports **ATM** over **T1**. The existing **HCAP** design for the **LIM-ATM**, with some modifications to the appliqué, is being used to accommodate the **E1 ATM** connectivity to the **EAGLE**.

This feature provides a new **E1** interface capability on the **EAGLE**. This new capability is provided using the existing **LIM-ATM** via an **HCAP** card, a new Applique' **ATM (AATM)** daughterboard, and a new **GPL**. A modified **LIM-ATM** supporting 2.048 Mb/sec is here referenced as an **E1 ATM** card. The **E1 ATM** capability supports a single **ATM Virtual Channel Connection (VCC)** at a line speed of 2.048 Mbps. The **E1 ATM** replaces the **MTP** layers 1 and 2, (**ITU-T Q.702** and **ITU-T Q.703**) with an **ATM**-based protocol (**ITU-T Q.2110**, **Q.2140** and **Q.2144**). **ATM** is used as the transport technology for carrying the signaling information via **PDU**'s between network nodes.

Refer to the **NSD Hardware Manual** for detailed hardware information.

New Hardware

E1 ATM LIM provides one **Asynchronous Transfer Mode** over **E1** Interface at 2.048 Mbps, (P/N 870-1293-xx). This module uses an **E1 Asynchronous Transfer Mode** Applique (**E1 ATM**) installed on a High Capacity Application Processor (**HCAP**) main assembly. The **E1 ATM** applique provides a new communications capability on the **EAGLE**, a High Speed Link (**HSL**) using **ATM** over **E1**. This capability is provided using the existing **HCAP** card, a new applique, and a new **GPL (ATMITU)**.

Refer to the **NSD Hardware Manual** for detailed hardware information.

Limitations

OAM F5 Performance Monitoring

ATMANSI does not provide **OAM F5** performance monitoring. This capability has not been added for this feature. Because the anticipated deployment of this feature is as a direct connection, performance monitoring of the network is not anticipated to supply any additional information that **SAAL** does not.

OAM F5 Fault Management

ATMANSI only provides **OAM F5** fault management for **OAM** loopback. It does not provide support for alarm surveillance and continuity check. These capabilities have not been added for this feature. Because the anticipated deployment of this feature is as a direct connection, fault management of the network is not anticipated to supply additional functionality.

Connection issues will be detected by the **SAAL** and the link will be deactivated if appropriate.

Traffic Size

Traffic size will have a definite impact on **MSU** throughput of the system; see table.

Table 2-27 Comparison of MSU Size to Throughput

MSU Size	ATM Packet Overhead	Cells/MSU	Max MSU/Sec
20	62%	1	2000
30	43%	1	2000
40	24%	1	2000
50	52%	2	1800
60	43%	2	1800
70	33%	2	1800
80	24%	2	1800
90	43%	3	1200
100	36%	3	1200
150	29%	4	900
200	24%	5	720
250	21%	6	600

AMI

AMI is not supported in this release. **HDB3** is the only supported encoding option for the **E1 ATM** card.

OVERSIZE MESSAGES

Oversize messages (>272 octets) will not be supported in this release. This limitation is a holdover from **ATMANSI**.

A general purpose implementation of the **ATM HSL** protocol stack would allow for 'Large **MSUs**' to be transferred across the physical link. The **SSCOP** layer is capable of handling data from **SSCF** that is up to 4096 bytes long. Since **SSCF** does not add a trailer to **MTP3** data, this equates to an **MTP3** packet of 4096 bytes.

However, the current implementation of the **ATM HSL** stack restricts the largest **MSU** size to 272 bytes of **MTP3** data. This restriction will be used for this feature, and as in the **ATMANSI** gpl, a the same **UIM** will be generated with a Large **MSU** is received.

2.112 E1/T1 MIM on EPM (E5-E1T1 Card) (Release 35.0)

Description

The E1/T1 MIM on EPM feature provides a single-slot, high-density E5-E1T1 card for channelized E1 and T1 link solutions. This card can be operated with a 40 Amp frame-level power budget and does not require a fan.

The E5-E1T1 card can be assigned a maximum of 32 signaling links of configurable channelized T1 connectivity. The links on the card can operate in a linkset with other

links running at different speeds. The total number of provisioned T1 links cannot exceed the allowed system maximum (the quantity shown for the Large System # Links entry in the `rtv-ctrl-feat` command output).

The E5-E1T1 card terminates 8 E1/T1 ports (trunks) and routes them to the A and B ports of the EAGLE 5 ISS backplane. These ports can be configured to select which E1/T1 ports are active and which channels on each port are used for signaling links.

The E5-E1T1 card supports one SE-HSL signaling link on one of the eight ports. Channelized operation is not possible on any E5-E1T1 card that is provisioned for SE-HSL. SE-HSL requires a Feature Access Key on a system level basis. The E5-E1T1 card provides copying and time-stamping of MSUs for all provisioned signaling links (up to 32 LSLs or 1 SE-HSL) simultaneously when the EAGLE 5 Integrated Monitoring Support (E5IS) feature is turned on.

 **Note:**

EAGLE 5 ISS Release 35.0 supports only the T1 functions on the card. The E1 functions will be available in EAGLE 5 ISS Release 35.1.

Modes of Operation

The E5-E1T1 card can be provisioned to operate in the E1 or T1 mode. The mode of operation defines the trunk format for the 8 ports on the card.

Along with the T1 mode, the E5-E1T1 card provides a Channel Bridging function that allows users to utilize T1 bandwidth that is not used by EAGLE 5 ISS signaling links. T1 ports 1, 3, 5, and 7 (master ports) can be independently channel bridged with their adjacent even-numbered (slave) T1 ports 2, 4, 6, and 8 to allow non-signaling data pass-through.

In T1 mode, the E5-E1T1 card generates an idle code in idle (unused) time slots. If the Channel Bridging function is used, idle codes are inserted into timeslots on even ports corresponding to the reflected signaling channels on the odd port.

EAGLE 5 ISS supports the Channel Bridging function for all combinations of master/line timing modes invoked by the adjacent equipment. Internal clock selection criteria ensure synchronous data paths through the bridged channels.

Thermal Management

The E5-E1T1 card includes and alarming provisions to protect the card from damage if environmental conditions hinder thermal stability. The EAGLE 5 ISS responses to increasing temperatures are as follows:

- Temp1 Exceeded—Major alarm raised
- Temp2 Exceeded—Critical alarm raised; failover initiated, traffic rerouted
- Temperature abated. Normal operation restored

Hardware Requirements

The E1/T1 MIM on EPM feature has the following hardware requirement::

- HIPR cards are required on each shelf that contains E5-E1T1 cards.

Limitations

The E1/T1 MIM on EPM feature has the following limitation:

- The E1 functions are not supported in EAGLE 5 ISS Release 35.0.

2.113 E1/T1 MIM on EPM (Release 35.1)

Description

The **E1/T1MIM on EPM** feature enhances the **E1/T1 MIM on EPM** feature from Release 35.0 by adding **EAGLE 5 ISS** support for **E1** functionality and **SE-HSL** links. This Feature Notice documents only these enhancements. Refer to the **EAGLE 5 ISS 35.0** Feature Notice for a detailed discussion of the **E1/T1 MIM on EPM** feature.

With support for the **E1** functionality, the **E5-E1T1** card can terminate 8 **E1/T1** ports (trunks) and route them to the A and B ports of the **EAGLE 5 ISS** backplane. These ports can be configured to select which **E1/T1** ports are active and which channels on each port are used for signaling links.

The **E5-E1T1** card supports one **SE-HSL** signaling link on one of the 8 ports. Support for **SE-HSL** requires a system-level **Feature Access Key**.

The **E5-E1T1** card provides copying and time-stamping of **MSUs** for all provisioned signaling links (up to 32 low-speed links) simultaneously when the **EAGLE 5** Integrated Monitoring Support (**E5IS**) feature is turned on.

Modes of Operation

The **E5-E1T1** card can be provisioned to operate in the E1 or T1 mode. The mode of operation defines the trunk format for the 8 ports on the card.

In T1 mode, a port represents a time-division-multiplexed data stream of 24 channels with an aggregate data rate of 1.544 Mbps. In E1 mode, a port represents a time-division-multiplexed data stream of 32 channels with an aggregate data rate of 2.048 Mbps.

E1 and T1 port configurations cannot be mixed on a single card. The **E5-E1T1** card provides a Channel Bridging function that allows use of **E1T1** bandwidth that is not used by **EAGLE 5 ISS** signaling links. E1 and T1 ports 1, 3, 5, and 7 (master ports) can be independently channel bridged with their adjacent even-numbered (slave) E1 and T1 ports 2, 4, 6, and 8 to allow non-signaling data pass-through.

In the E1 or T1 mode, the **E5-E1T1** card generates an idle code in idle (unused) time slots. If the Channel Bridging function is used, idle codes are inserted into timeslots on even ports corresponding to the reflected signaling channels on the odd port.

EAGLE 5 ISS supports the Channel Bridging function for all combinations of master/line timing modes invoked by the adjacent equipment. Internal clock selection criteria ensure synchronous data paths through the bridged channels.

Note:

Channelized operation cannot be performed on any **E5-E1T1** card that is provisioned for **SE-HSL**.

Hardware Requirements

The **E1/T1 MIM** on **EPM** feature requires **HIPR** cards on each shelf that contains **E5-E1T1** cards.

Limitations

The **E1/T1 MIM** on **EPM** feature has the following limitations:

- **E1** and **T1** port configurations cannot be mixed on a single card.
- Channelized operation cannot be performed for any **E5-E1T1** card that supports **SE-HSL** links.

2.114 E1/T1 Multi-Channel Interface Module (Release 28.0) (IP7 Release 6.0)

The **E1/T1 Multi-Channel Interface Module (MIM)** provides increased **E1** signaling connectivity and a channelized **T1** connection to the **EAGLE STP**.

The **MIM** increases the number of **SS7** links (ports) the **EAGLE** handles per **E1** card. This allows the **EAGLE** to interact in larger **SS7** networks, as well as decreases the footprint of an **EAGLE** (i.e. previously 250 cards were required to support 500 links; now only 63 cards are required). The **E1/T1 MIM** can be used in systems equipped with either the **IPMX** or the **HMUX** board. The **MIM** also provides a new channelized **T1** connection to the **EAGLE**. The **MIM** can replace an existing **LIME1/LIMCH** card (as an **E1** terminating card or **E1** channel card), with no reprovisioning required. **E1 MIM** is hot-swappable with **LIM-E1**.



Note:

For existing **E1** customers, the **E1** Administration feature will be activated after upgrading to Release 28.0, unless the source release is 26.3.

The **E1/T1 Multi-Channel Interface Module (MIM)** card has 2 physical backplane port connections, as other **LIM** cards do. These are referred to here as interface A and interface B. For the **E1/T1 MIM**, as with the existing **LIM-E1** card, interface A has 2 ports of **E1/T1** connectivity. These 2 ports are referred to as port #1 and port #2. Interface B provides the expansion port to service channel cards.

Refer to the **Database Administration Manual - SS7** for detailed and configuration information.

Hardware Requirements

No new hardware other than the new **MIM** card itself (870-2198-01) is needed to support this feature.

For detailed information on hardware, refer to the **NSD Hardware Manual**.

2.115 E5-APP-B Card (ELAP 10.0)

The E5-APP-B card is designed to be integrated with applications that run on a Signal Transfer Point (STP). E5-APP-B cards are installed as a pair in an EAGLE shelf along with Ethernet communication equipment. For more information about EAGLE shelves, refer to *EAGLE Hardware Manual*.

The E5-APP-B card is a general-purpose application server (AS) that offers high transaction rates with low latency. The E5-APP-B card is a scalable computing platform constructed with state-of-the-art components packaged on a double-width card designed to fit into two slots of an EAGLE shelf. Each E5-APP-B card has two field-replaceable hard disk drives for data storage. Each E5-APP-B card is delivered pre-loaded with platform software and application software. E5-APP-B cards are installed as a pair for redundancy and high availability. DSM Service Module cards (870-1984-xx) are not supported with E5-APP-B based applications.

For more information about the E5-APP-B card, refer to the new manuals which fully describe the card and its installation, operation, and maintenance:

- *E5-APP-B Hardware and Installation Manual*
- *ELAP Alarms and Maintenance on the E5-APP-B Platform*

2.116 E5-APP-B Card (EPAP 15.0)

The E5-APP-B card is designed to be integrated with applications that run on a Signal Transfer Point (STP). E5-APP-B cards are installed as a pair in an EAGLE shelf along with Ethernet communication equipment. For more information about EAGLE shelves, refer to *EAGLE Hardware Manual*.

The E5-APP-B card is a general-purpose application server (AS) that offers high transaction rates with low latency. The E5-APP-B card is a scalable computing platform constructed with state-of-the-art components packaged on a double-width card designed to fit into two slots of an EAGLE shelf. Each E5-APP-B card has two field-replaceable hard disk drives for data storage. Each E5-APP-B card is delivered pre-loaded with platform software and application software. E5-APP-B cards are installed as a pair for redundancy and high availability. DSM Service Module cards (870-1984-xx) are not supported with E5-APP-B based EPAP systems.

For more information about the E5-APP-B card, refer to the new manuals which fully describe the card and its installation, operation, and maintenance:

- *E5-APP-B Hardware and Installation Manual*
- *EPAP Alarms and Maintenance on the E5-APP-B Platform*

2.117 E5-ATM Card (Release 38.0)

The E5-ATM card supports both ANSI and ITU implementations for SS7 signaling information. This card can be used to replace the LIM-ATM and E1-ATM cards; however, the LIM-ATM and the E1-ATM cards are still supported and can co-exist with the E5-ATM card in the same node.

The E5-ATM card supports a new **atmhc** GPL.

The E5-ATM card can support 2 ATM signaling links, operating at 1 Erlang. The card can be configured for either E1 (ITU) or T1 (ANSI). Both links must be either E1 or T1.

If the B signaling link is provisioned, then the card slot is no longer compatible with the LIM-ATM or E1-ATM cards. Inserting one of these cards after provisioning the B link causes the card to auto-inhibit.

2.117.1 Feature Control Requirements

There are no feature control requirements identified for this feature.

2.117.2 Hardware Requirements

HIPR cards must be installed in the shelf where the E5-ATM card is installed.

The E5-ATM card provides connectivity for two E1/T1 ports on the Port A backplane connector, allowing the two links to be provisioned. These ports can be accessed with a 2-port or 4-port cable. An interface adapter (P/N 830-1342-05) allows the two ports to be physically split to two different cables/patch panels. If it is desired to move the second E1/T1 port to the Port B backplane connector, then an adapter and another cable (1-, 2-, or 4-port) must be used.

2.117.3 Limitations

The E5-ATM platform does not preserve memory across boots. The data may not remain intact across card boots.

2.118 E5-ATM-B (Release 44.0)

A new E5-ATM-B card (Part Number 870-2972-01) is introduced. This card is based on the EPM-B module. See [EPM-B Based Cards\(Release 44.0\)](#) for information common to all cards based on the EPM-B.

E5-ATM-B cards can be inserted in slots that are provisioned for ATMANSI or ATMITU applications. The card is provisioned using the `ent-card` command with `type=limatm` and `appl=atmansi` for ANSI or `type=limelatm` and `appl=atmitu` for ITU.

2.118.1 Feature Control Requirements

Message Flow Control (MFC) and the Fan feature must be on before an E5-ATM-B card can be brought into service. See [Message Flow Control Replacement for TVG \(Release 44.0\)](#) for more information.

If MFC and the Fan feature are on, then E5-ATM-B cards can co-exist with and be used to replace E5-ATM cards (Part Numbers 870-1872-XX) without configuration changes. If MFC or the Fan feature is off, then the E5-ATM-B cards will auto-inhibit.

When the EAGLE contains B-series cards which include E5-ENET-B, E5-ATM-B, E5-SM8G-B, and E5-E1T1-B, the following cards are not supported in EAGLE Release 44.0 except during migration to the B-series cards:

- DCM card (870-1945-xx)
- DSM card (870-1984-xx)

- EDCM card (870-2372-xx) used for SLAN or STC functionality
- EDCM-A card (870-2508-xx) used for SLAN or STC functionality

2.119 E5-E1T1-B (Release 45.0)

The E5-E1T1-B card (Part Number 870-2970-01) is a single slot card based on the EPM-B module and can be inserted in slots provisioned for SS7ANSI or CCS7ITU applications.

The E5-E1T1-B card is provisioned using the `ent-card` command with the `type=lime1` or `type=limt1` parameter. The `appl=ss7ansi` parameter is used for ANSI, and the `appl=ccs7itu` parameter is used for ITU.

The E5-E1T1-B card provides eight E1 or T1 termination ports, processing up to 32 signaling links of configurable channelized E1 or T1 connectivity. The eight ports reside on backplane connectors A and B. All ports on a single E5-E1T1-B card must operate in the same carrier scheme of E1 or T1. An EAGLE node can have a mix of E1 and T1 signaling links with some E5-E1T1-B cards operating in E1 mode and other E5-E1T1-B cards operating in T1 mode.

The maximum provisionable links for the E5-E1T1-B card is 32 links. Total system signaling link capacity depends on other cards in the system and the enabled features, and must not exceed the provisioning limit of the EAGLE.

Channelized Mode

The E5-E1T1-B card provides access to eight E1 or T1 ports residing on backplane connectors A and B. Each data stream consists of 24 T1 or 31 E1 signaling links assigned according to a Time-Division Multiplex (TDM) scheme. Each **channel** occupies a unique timeslot in the data stream and can be selected as a local signaling link on the interface card. Each card can select up to a total of 32 signaling links.

Channel Bridging

Channel Bridging is the processing of signaling channels that are intermixed on trunks with voice or data channels. The E5-E1T1-B card provides Channel Bridging which allows for better utilization of bandwidth without dedicating entire trunks to signaling. Non-signaling channels are bridged to an adjacent E1 or T1 port for transport to other network devices. Signaling channels are merged to non-signaling data for transmission to the mixed network.

2.119.1 Hardware Requirements

- Fan trays must be installed on shelves that contain E5-E1T1-B cards.
- The IMT bus must contain at least one HIPR or HIPR2 card before an E5-E1T1-B card can connect with the bus. If HMUX cards are used, then the cards cannot access the IMT bus. If the shelf contains both HMUX and HIPR/HIPR2 cards, then the E5-E1T1-B card connects with the HIPR/HIPR2 cards only. HMUX cards with HIPR/HIPR2 cards on the same shelf are supported only during migration to the E5-E1T1-B cards.
- Dual 60A power feeds are recommended for all frames that host E5-E1T1-B cards.

- The BLMCAP GPL must be flashed on E5-E1T1-B cards before the card can be initialized.

2.120 E5-E1T1-B Increased Throughput (Release 46.0)

The E5-E1T1-B Increased Throughput increases the number of supported low speed links per E5-E1T1-B card from 32 to 64.

2.121 E5-ENET SLAN to ECAP (Release 41.1)

The E5-ENET SLAN to ECAP feature allows the ECAP server to interface with E5-ENET cards. EDCM and EDCM-A cards continue to be supported.

2.122 E5-ENET-B (Release 44.0)

A new E5-ENET-B card (Part Number 870-2971-01) is introduced. This card is based on the EPM-B module. See [EPM-B Based Cards\(Release 44.0\)](#) for information common to all cards based on the EPM-B.

The E5-ENET-B card can be used with the EROUTE, IPGW, IPLIM, IPLIMI, IPS, IPST, SS7IPGW, and STPLAN applications.

E5-ENET-B with EROUTE

E5-ENET-B cards can be used in slots that are provisioned for the EROUTE application. The card is provisioned using the `ent-card` command with `type=stc` and `appl=eroute`.

E5-ENET-B with IPGWx, IPLIMx, SS7IPGW

E5-ENET-B cards can be used in slots that are provisioned for the IPGWI, IPLIM, IPLIMI, or SS7IPGW application. The card is provisioned using the `ent-card` command with `type=dcm` and `appl=ipgwi/iplim/iplimi/ss7ipgw`.

E5-ENET-B with IPS

See [IPS Application on E5-ENET-B \(Release 44.0\)](#) for information on the E5-ENET-B card running the IPS application.

E5-ENET-B with IPST

E5-ENET-B cards can be used in slots that are provisioned for the IPST application. A new ENETB card type is introduced for use with the E5-ENET-B card and IPST application. The card is provisioned using the `ent-card` command with `type=enetb` and `appl=ipst`.

An E5-ENET-B card with the IPST application has a capacity of 6500 TPS. If E5-ENET-B cards are installed in slots that are provisioned for E5-ENET cards, then the E5-ENET-B cards process at 5000 TPS. If an E5-ENET card is installed in a slot provisioned for an E5-ENET-B card, then the E5-ENET card auto-inhibits.

If the [E5-ENET-B IPST High Throughput \(Release 44.0\)](#) feature is turned on, then the E5-ENET-B cards process at rates up to 9500 TPS.

E5-ENET-B with STPLAN

E5-ENET-B cards can be used in slots that are provisioned for the STPLAN application. The card is provisioned using the `ent-card` command with `type=dcm` and `appl=stplan`.

2.122.1 Feature Control Requirements

Message Flow Control (MFC) and the Fan feature must be on before an E5-ENET-B card running the EROUTE, IPGW, IPGWI, IPLIM, IPLIMI, or IPSG application can be brought into service. See [Message Flow Control Replacement for TVG \(Release 44.0\)](#) for additional information on MFC.

Note:

The E5-ENET-B card running the IPS application does not require MFC. See [IPS Application on E5-ENET-B \(Release 44.0\)](#) for additional information.

If MFC and the Fan feature are on, then E5-ENET-B cards can co-exist with and be used to replace E5-ENET cards (Part Numbers 870-2212-XX), EDCM cards (Part Numbers 870-2372-XX) and EDCM-A cards (Part Numbers 870-2508-XX) without configuration changes. If MFC or the Fan feature is off, then the E5-ENET-B cards will auto-inhibit.

When the EAGLE contains B-series cards which include E5-ENET-B, E5-ATM-B, E5-SM8G-B, and E5-E1T1-B, the following cards are not supported in EAGLE Release 44.0 except during migration to the B-series cards:

- DCM card (870-1945-xx)
- DSM card (870-1984-xx)
- EDCM card (870-2372-xx) used for SLAN or STC functionality
- EDCM-A card (870-2508-xx) used for SLAN or STC functionality

2.123 E5-ENET-B IPSG High Throughput (Release 44.0)

The E5-ENET-B IPSG High Throughput feature allows an [E5-ENET-B \(Release 44.0\)](#) card running the IPSG application to have a capacity of up to 9500 TPS.

If the feature is not turned on, then an E5-ENET-B card running the IPSG application continues to have a capacity of 6500 TPS.

Turning on the E5-ENET-B IPSG High Throughput feature impacts the baseline configuration for the E5-ENET-B card running the IPSG application as shown in [Table 2-28](#).

Table 2-28 Baseline Configuration Changes for the E5-ENET-B IPSG High Throughput Feature

E5-ENET-B Card Baseline Configuration	E5-ENET-B IPSG High Throughput feature OFF	E5-ENET-B IPSG High Throughput feature ON
Maximum TPS for the card	6500	9500
Average MSU size (bytes)	0-272	0-120
Max RTT (ms)	120	50
Max number of links/associations	16	4
Protocol	M2PA and M3UA	M2PA

**Note:**

Standard de-rating considerations apply.

2.123.1 Feature Control Requirements

- FAK for Part Number 893-0395-01
- A temporary FAK cannot be used to enable the feature.
- The feature can be turned on and off.
- The feature cannot be turned off if any E5-ENET-B card has a configured card capacity greater than 6500 TPS.

2.124 E5-MCPM-B (Release 44.0)

A new E5-MCPM-B card (Part Number 870-3089-01) is introduced. This card is based on the EPM-B module and is used to replace the EDSM-2G cards (Part Numbers 870-2372-XX). See [EPM-B Based Cards\(Release 44.0\)](#) for information common to all cards that are based on the EPM-B.

EDSM-2G and E5-MCPM-B cards are referred to collectively as MCPM cards.

The E5-MCPM-B card is used to perform Measurements Collection Processor and E5-OAM Integrated Measurements functionality for nodes with a link capacity greater than 2,400 (1,200 if the 15 Minute Measurements feature is enabled). E5-OAM Integrated Measurements is used for nodes with a link capacity of 2400/1200 or less.

E5-MCPM-B cards can be inserted in slots that are provisioned for the MCP application. The card is provisioned using the `ent-card` command with `type=mcpm` and `appl=mcp`. A new MCPHC GPL is introduced to run the Measurements Platform feature on the E5-MCPM-B cards.

2.124.1 Feature Control Requirements

The Fan feature must be turned on before an E5-MCPM-B card can be brought into service.

If the Fan feature is turned on, then E5-MCPM-B cards can co-exist with and be used to replace EDSM-2G cards (Part Numbers 870-2372-XX) without configuration changes. If the Fan feature is off, then the E5-MCPM-B cards will auto-inhibit.

2.124.2 Hardware Requirements

- Backplane cable adapter 830-1103-xx is needed to connect to the E5-MCPM-B card.
- Backplane cable adapter 830-1102-xx is needed when using shielded CAT-5[23] Ethernet cables for TCP/IP connection to the external host.

2.125 E5-OAM Cards (E5-MASP and E5-MDAL) (Release 40.1)

The existing set of EAGLE 5 ISS OA&M cards (GPSM-II, TDM, and MDAL cards) is replaced by an E5-OAM card set. This set contains an E5-MASP assembly (870-2903-01) and an **E5-MDAL card** (870-2900-01).

The E5-MASP assembly consists of an **E5-MCAP card** and an **E5-TDM card**. These cards are physically attached to each other and must always be used or replaced together. The E5-MASP assembly can be inserted into slots 1113/1114 or 1115/1116.

The E5-MDAL card can be inserted into slot 1117.

Two E5-MASP assemblies and an E5-MDAL card comprise an E5-OAM set.

Legacy GPSM-II, TDM, or MCAP cards cannot exist in the system with any of the new cards. All of the relevant cards must be legacy or all of the cards must be new. The only exception is during a hardware migration from a legacy system to a new system.

A new **blmcap** flash GPL is used to maintain a tar image of the code that is required for the E5-MCAP cards. A new **oamhc** GPL is used to perform OAM functions on the E5-MCAP cards.

The drive configuration for the E5-OAM card set significantly differs from the OAM card set. The E5-MDAL card does not contain an optical drive. The E5-TDM contains a hard drive. The E5-MCAP card contains two USB ports, a latched port, which replaces the existing MO drive as the removable drive, and a flush mount port. After the E5-OAM card set is introduced, activities for those cards can be performed on either the hard drive or the removable drives.

2.125.1 Feature Control Requirements

There are no requirements associated with the E5-OAM card set.

2.125.2 Hardware Requirements

The E5-MASP assemblies require HIPR cards to be installed in the 1109 and 1110 slots.

2.126 E5-OAM Integrated GLS (Release 44.0)

The E5-OAM Integrated GLS feature (Integrated GLS) migrates Generic Loading Services (**GLS**) functionality for the Gateway Screening feature from the TSM (Part Numbers 870-1289-XX, 870-1291-XX, and 870-1292-XX) and E5-TSM (Part Number 870-2943-03) cards to the E5-OAM.

The Integrated GLS feature supports all TSM and E5-TSM card functionality. The feature can exist in mixed mode with TSM-based and E5-TSM-based GLS during migration.

2.126.1 Feature Control Requirements

- FAK for Part Number 893-0389-01
- The Gateway Screening feature must be turned on before the Integrated GLS feature can be enabled.
- A temporary FAK cannot be used to enable the feature.
- The feature can be turned on and off.

2.126.2 Hardware Requirements

E5-OAM cards must be installed before the Integrated GLS feature can be enabled. If EOAM cards are installed, then the feature cannot be enabled.

2.127 E5-OAM Integrated Measurements (Release 42.0)

The E5-OAM Integrated Measurements (Integrated Measurements) feature allows the Measurements subsystem on the E5-OAM MASP to provide full support for the collection and reporting for all collectible measurement entities for nodes configured with up to 1200 links. Systems with more than 1200 links must install the Measurements Control Platform (MCP) for full measurement support.

The Integrated Measurements feature obsoletes the use of the File Transfer Area (FTA) for measurements, and replaces the **FTA** functionality with **FTP** functionality. The E5-OAM/IP Ethernet Support enhancement is used to provide Ethernet support for FTP.

This feature requires the Measurements Subsystem to transition to the Integrated Measurements. The transition is performed by provisioning the `oamhcmeas` option in the `chg-measopts` command. Provisioning this parameter also turns on the Integrated Measurements collection function.



Note:

The Integrated Measurements collection function cannot be turned off after it has been turned on.

If the MCP is enabled prior to the transition, then the transition sequence transfers all historical measurements data from the MCP to the OAM. The MCP does not collect and report measurements during transition.

After the transition is complete, the OAM takes control of the Measurements Subsystem and is responsible for collection and reporting. The **MCPM** cards are set to **IS-ANR** - Restricted state, and the MCP is turned off.

2.127.1 Feature Control Requirements

- FAK for Part Number 893-0373-01
- The feature cannot be turned off after it is turned on.

- A temporary FAK cannot be used to enable the feature.

2.127.2 Hardware Requirements

E5-OAM hardware must be installed before the Integrated Measurements feature can be enabled. The feature cannot be enabled if EOAM hardware is installed in either MASP slot.

2.128 E5-OAM SNMP Support (Release 45.0)

The E5-OAM SNMP Support feature allows the EAGLE to communicate directly with a Network Management System (NMS) without requiring an intermediary Element Management System (EMS). After this feature is enabled and turned on, the SNMP traps for alarms are sent to an NMS or a set of NMSs specified by the `ent/chg/rtrv-snmp-host` commands. Configured NMSs can request a resynchronization for all of the existing UAMs. Each provisioned NMS receives a *heartbeatTrap* at a rate determined by the NMS declaration. The *heartbeatTrap* indicates to the NMS that the network connection is intact during periods of low UAM/UIM activity.

For each NMS, a host name and IP address must be specified with the `ent-snmp-host` command. Optional parameters allow the SNMP command and trap port numbers to be changed, as well as allow the TRAP community string to be specified for the traps sent to the NMS, and set the *heartbeatTrap* interval. After a host is provisioned, the optional parameters may be changed with the `chg-snmp-host` command. The system-wide SNMP options can be changed with the `chg-snmptpts` command. The `chg-snmptpts` command enables the GET and SET community strings to be changed, and enables or disables sending UIM as traps to the NMS.

2.128.1 Feature Control Requirements

- FAK for Part Number 893-0404-01
- A temporary FAK cannot be used to enable the feature.
- The feature can be turned on and off.
- The SNMP FAK must be enabled before any NMS hosts can be provisioned.

2.128.2 Hardware Requirements

Because the E5-OAM SNMP Support feature requires an Ethernet connection, the feature is supported only on the E5- MASP.

2.129 E5-SLAN Throughput Throttle for ECAP Connection (Release 41.1)

The E5-SLAN Throughput Throttle for ECAP Connection feature allows the TPS on E5-ENET cards to be restricted to avoid overloading the ECAP server, which can handle a maximum of 5000 TPS.

2.130 E5-SM4G Card (Release 37.0)

Description

The E5-SM4G card enhances the EAGLE 5 ISS support for the EPAP and ELAP-based features by providing performance improvement over the DSM cards that currently run the **vsccp** application. DSM cards will continue to be supported, but are being replaced with E5-SM4G cards for new initial and extension shipments.

The E5-SM4G card requires the E5-SM4G Throughput Capacity feature to be enabled to achieve maximum processing. A FAK is required to enable the E5-SM4G Throughput Capacity feature.

The new E5-SM4G card running the **sccphc** GPL and the **vsccp** application performs the same functions as the current DSM card for EPAP-based and ELAP-based features.

The E5-SM4G card is provisioned with card type **dsm** and the **vsccp** application, allowing the E5-SM4G card to replace a DSM card in the control or extension frame without re-provisioning.

The E5-SM4G Throughput Capacity feature performs the following functions:

- Allows each E5-SM4G card to operate at a rate of 5,000 TPS for SCCP traffic that is processed entirely by GTT.
- Allows each E5-SM4G card to operate at a rate of 3,125 TPS if part of the SCCP traffic is processed by EPAP-based features.
- Allows achievement of the maximum system TPS capacity provided by the 150,000 GTT TPS feature and the 75,000 EPAP TPS feature. See “150,000 GTT TPS and 75,000 EPAP TPS” on page FN-8.

If the E5-SM4G Throughput Capacity feature is not enabled, then the E5-SM4G card continues to operate at the DSM-equivalent capacities:

- GTT only mode=1700 TPS per E5-SM4G card
- EPAP-based feature node if the 1100 TPS/DSM feature is not enabled = 850 TPS per E5-SM4G card
- EPAP-based feature node if the 1100 TPS/DSM feature is enabled = 1100 TPS per E5-SM4G card

HIPR cards must be installed in any shelf that contains an E5-SM4G card. HIPR cards must be installed in all shelves in the system before the E5-SM4G Throughput Capacity feature can be enabled to increase the card and system TPS capacity.

The E5-SM4G card cannot be inserted into a node that is provisioned to process more than 192 million LNP numbers. If the E5-SM4G card is inserted into a node that can process more than 192 million LNP numbers, the card auto-inhibits.

The E5-SM4G card can co-exist with DSM cards and operate at a capacity of 5,000 TPS. The E5-SM4G card can co-exist with TSM cards that are used for GTT and GLS only, and can co-exist with two channel LIM cards per node.

The E5-SM4G card provides two physical 10/100 Mbps Ethernet ports.

The E5-SM4G card supports thermal management and alarming provisions.

Feature Control Requirements

If the E5-SM4G Throughput Capacity feature is used, then the following feature control requirements apply:

- A FAK for part number 893-0191-01
- A temporary key cannot be used to enable the feature.
- After the feature has been turned on, it cannot be turned off.
- The feature cannot be enabled if any of the following features or options is turned on:
 - E5IS (EAGLE 5 Integrated Monitoring Support) feature
 - LNP feature
 - ANSIGFLEX STP option

Hardware Requirements

The E5-SM4G card requires HIPR cards in card locations 9 and 10 in the shelf in which it is installed.

Limitations

The E5-SM4G card provides 3.1 GB of memory while the DSM card provides approximately 3.6 GB of memory. This reduction in memory limits the number of entries to a maximum of 84 million for EPAP applications and 192 million for LNP. Additional E5-SM4G cards may be required to match the processing capacity of DSM for these applications.

2.131 E5-SM8G-B (Release 44.0)

A new E5-SM8G-B card (Part Number 870-2990-01) is introduced. The E5-SM8G-B card is a dual-slot card with a dual-core processor.

The E5-SM8G-B card can be inserted in slots that are provisioned for the VSCCP application. The card is provisioned using the `ent-card` command with `type=dsm` and `appl=vsccp`.

As of Release 44, references to **Service Module cards** include E5-SM8G-B cards.

A new performance key is introduced for the E5-SM4G Throughput Capacity feature. This key (Part Number 893-0191-03) is supported only on the E5-SM8G-B card and allows the card to run at 10,000 TPS. The E5-SM8G-B card also supports the existing E5-SM4G Throughput Capacity performance keys at their associated TPS levels.

2.131.1 Feature Control Requirements

Message Flow Control (MFC) functionality and the Fan feature must be on before an E5-SM8G-B card can be brought into service. See [Message Flow Control Replacement for TVG \(Release 44.0\)](#) for more information.

If MFC and the Fan feature are on, then E5-SM8G-B cards can co-exist with and be used to replace DSM (Part Numbers 870-1984-XX) and E5-SM4G (Part Numbers

870-2860-XX) cards without configuration changes. If MFC or the Fan feature is off, then the E5-SM8G-B cards will auto-inhibit.

The new E5-SM4G Throughput Capacity performance level (Part Number 893-0191-03) must be enabled before the E5-SM8G-B card can run at 10,000 TPS.

When the EAGLE contains B-series cards which include E5-ENET-B, E5-ATM-B, E5-SM8G-B, and E5-E1T1-B, the following cards are not supported in EAGLE Release 44.0 except during migration to the B-series cards:

- DCM card (870-1945-xx)
- DSM card (870-1984-xx)
- EDCM card (870-2372-xx) used for SLAN or STC functionality
- EDCM-A card (870-2508-xx) used for SLAN or STC functionality

2.131.2 Hardware Requirements

- Fan trays must be installed on shelves that contain E5-SM8G-B cards.
- The IMT bus must contain at least one HIPR or HIPR2 card before an E5-SM8G-B card can connect with the bus. If HMUX cards are used, then the cards cannot access the IMT bus. If the shelf contains both HMUX and HIPR/HIPR2 cards, then the E5-SM8G-B card connects with the HIPR/HIPR2 cards only.

Note:

HMUX cards with HIPR/HIPR2 cards on the same shelf are supported only during migration to the EPM-B based cards.

2.132 EAGLE Alarm Modifications for Synchronization with Harris (Release 31.5)

Description

There is an issue between the Harris monitoring system and the alarm generation/clearing shown by the **EAGLE**. There are multiple instances where the **EAGLE** will either silently clear an alarm, or silently refresh an alarm to a different alarm. Since the Harris system is relying on the **EAGLE** output to set or clear alarms on **EAGLE** devices, the two systems alarming counts are frequently out of sync.

Limitations

If a customer is only using a normal **KSR** terminal for monitoring, there is a potential to drop alarms from the terminals output if the output buffers fill up with data such as hourly reports, **IMT** reports, Measurements reports, excessive **UIM** output, etc. There are ways to minimize this extra output to significantly reduce the likelihood of such a buffer overflow:

- Turn off Traffic output group (**TRAF**) for the terminal used by Harris
- Use **UIM** thresholding

**Note:**

using the new **EMSALM** terminal solves this limitation

Due to the sheer number of Alarms that are potentially generated during link alignments for an **EAGLE** with a large number of signaling links, the multiple signaling link alarm states continue to be done without output. The first Signalling **Link** alarm is output but subsequent alarms for that device transition silently. This suppression of output is **OK** for signaling links, in that all the signaling link silent alarm transitions are within the same alarm level, **MAJR**. When the signaling link alarms are cleared, there is an appropriate clearing alarm issued for each affected link. To cycle through and issue each overtaking signaling alarm for every link over an "init-sys" on a large system output overwhelms the output buffer, and alarms would be lost.

In the event that the Harris system's alarms get out of Sync with the **EAGLE**'s alarms, it is up to the Harris system both to detect and correct its alarm counts to match that of the **EAGLE**.

2.133 EAGLE Collector Application Processor (ECAP) on the T1200 Platform (ECAP 41.1)

ECAP release 41.1 will support a new T1200 server, along with the existing support for the T1100 server. All existing ECAP functionality (from prior releases 1.0 and 40.1) supported on the T1100 will now be supported on the T1200. Also, new ECAP functionality introduced in release 41.1 will be supported on both the T1100 and the T1200 servers. For more information, refer to the *Feature Manual - ECAP*.

Operating System

The ECAP server operates on the Tekelec Platform Development (TPD) 3.3 32-bit (i686/i386) Linux distribution operating system.

TPD 3.3

TPD 3.3 provides a method for trapping platform Alarm conditions. ECAP installation turns on the **TPD snmpAgent**, and enables configuration of the agent via the **platcfg** menu.

In addition to **ecapadm**, ECAP installation provides an **ecapuser** account. This is a limited account that can NOT control or configure the ECAP application via **ecapcfg**.

For additional information regarding the ECAP server's architecture, processor type, and node name, execute the **uname -a** command on each server to generate output such as this example:

Output Example

```
# uname -a
Linux ECAP 2.6.18-1.2849prere13.3.0_63.1.0 #1 SMP Thu Nov 13 02:48:50
EST 2008 i686 i686 i386 GNU/Linux
```

2.133.1 Hardware Requirements

Hardware requirements for the **ECAP** on the T1200 platform are as follows:

- T1200 AS Frame

 **Note:**

EAGLE 5 ISS supports a single ECAP Frame.

- Power Distribution breaker panel
- Two or four Telco switches

 **Note:**

Two switches (one pair) must be configured if 12 ECAP servers or less are configured. Four switches (two pair) must be configured if more than 12 ECAP servers are configured.

- A T1200 server , running the Integrated Q.752 **MTP/SCCP** Accounting Feed feature.
- The number of T1200 ECAP Servers per frame is two to eighteen.
- The **EAGLE 5 ISS** system used with the **ECAP** must be equipped with **SSEDCM** or E5-ENET card types running the SLAN application. The SLAN application cards must be provisioned with 100 Mbps links in order to achieve 10000 **MSUs/sec**.

The **ECAP** Servers are configured in an N+1 configuration based on the maximum expected traffic rate as shown in [Table 2-29](#).

Table 2-29 MSU to T1200 Server Mapping

MSU per Second	T1200 Servers
<= 10000	2
10001 to 20000	3
20001 to 30000	4
30001 to 40000	5
40001 to 50000	6
50001 to 60000	7
60001 to 70000	8
70001 to 80000	9
80001 to 90000	10
90001 to 100000	11
100001 to 110000	12
110001 to 120000	13
120001 to 130000	14
130001 to 140000	15

Table 2-29 (Cont.) MSU to T1200 Server Mapping

MSU per Second	T1200 Servers
140001 to 150000	16
150001 to 160000	17
160001 to 170000	18

Memory and Disk Space

The ECAP application can be installed on either of these hardware platforms:

- T1100 server consisting of two mirrored 250 GB hard drives
- T1200 server consisting of three mirrored 146 GB hard drives

Memory and disk requirements for the ECAP application are due to the massive amounts of data that can be collected from the EAGLE 5 ISS. The ECAP installation take about 10-12 MB of disk space.

2.134 EAGLE Database Increase to 480M DN + 600M Flexible IMSI/IMEI Allocation (Release 46.7)

In cooperation with the EPAP eXtreme (EPAPX) DB Expansion feature, the EPAP is able to support 480M individual DN entries, 600M individual IMSI entries or 600M individual IMEI entries. The EPAPX feature is supported only for 64-bit flash running on an EAGLE system for SLIC cards. The EPAPX feature cannot be turned on if the system is equipped with SM8G-B cards to run EPAP-based features.

When the EPAP is running on Release 16.3 with its full capacity, DN-based SLIC-SCCP cards are able to load 480M individual DN entries. IMSI-based SLIC-SCCP cards are able to load 480M individual IMSI entries or 600M individual IMEI entries. This is applicable when the EPAP Split DB feature is ON. DB allocation to EAGLE EPAP-based cards is flexible, as per the configurations done on the EPAP side.

If the EPAP Split DB feature is OFF, then the DN & IMSI tables are loaded onto a single EPAP card. In this case the DN + IMSI entries must be less than 480M. The exact allowed combinations are listed in the [Table 2-30](#).

Table 2-30 EAGLE Feature and EPAPX DB Capacity Combinations

EPA P Split DB Feature	STPOPTS: EPAX	Max Ind. DNs	Max Ind. IMSIs	Max Ind. DNs = Ind. IMSIs	Max Ind. IMEIs	Max RTDB Size (DN=IMSI=IMEI) supported on Ind. SLIC
OFF	OFF, EPAP240M OFF	120M	120M	120M	48M	120M (DN) 135M (IMSI)
ON	OFF, EPAP240M OFF	120M	120M	240M	48M	120M (DN) 135M (IMSI)

Table 2-30 (Cont.) EAGLE Feature and EPAPX DB Capacity Combinations

EPA P Split DB Feat ure	STPOPTS: EPAX	Max Ind. DNs	Max Ind. IMSI	Max Ind. DNs = Ind. IMSI	Max Ind. IMEI	Max RTDB Size (DN=IMSI+ IMEI) supported on Ind. SLIC
ON	OFF, EPAP240M ON	240M	240M	480M	48M	240M (DN) 288M (IMSI) 528M (EPAP)
OFF	ON	480M	480M	480M	480M	480M (DN + IMSI + IMEI)
ON	ON	480M	600M	1080M	600M	480M DN 600M IMSI

To enable the 480M DN & 480M IMSI/600M IMEI capacity expansion on EAGLE, the `epapx` parameter is introduced in the STPOPTS table. The SLIC-SCCP cards on EAGLE are able to load 480M DN entries only when the `stpopts:epapx` parameter is ON. Similarly, SLIC-SCCP cards on EAGLE are able to load 480M IMSI or 600M IMEI entries only when the `stpopts:EPAPX` parameter is ON.

See "Activating the EPAPX DB Expansion Feature" in *Database Administration - GTT User's Guide* for more information.

2.135 Eagle Eyes OAM Friendly Commands (Release 46.0)

The Eagle Eyes OAM Friendly Commands feature allows users to configure and perform Eagle Eyes traffic captures using OAM commands.

2.136 EAGLE Frame Power Budget Alarm (Release 35.0)

Description

The EAGLE Frame Power Budget Alarm feature issues an alarm if the power consumption of cards in a frame nears the frame-level power capacity. The power capacity value can be provisioned in the Frame Power Threshold (FPT) table or a default value of 30 Amps can be used.



Note:

The value in the FPT table would be provisioned based on FAP configuration and power feed.

The feature identifies the type of cards in a frame, calculates potential power consumption based on the frame-level population of cards, compares calculated power consumption to a frame-level power capacity figure, and raises alarms based on provisioned thresholds.

The new `rtrv-stp` command can be used to display the power consumption and power threshold values for all frames or a specific frame in the system.

Hardware Requirements

None

Limitations

The EAGLE Frame Power Budget Alarm feature has the following limitation:

- During initialization and switchover, frame power consumption is calculated using information from the various cards; therefore, the correct power consumption value is calculated only after information from all of the cards have been processed by the Frame Power Budget Alarm task.

2.137 EAGLE Initiated OAP User Interface (Release 24.0)

Description

In Release 24.0, the **OAP** configuration information is entered from the **EAGLE** terminals into the **EAGLE** database. When the configuration of an **OAP** needs to be updated, the **OAP** configuration data in the **EAGLE** database is sent to the specified **OAP**.

OAP Commands

The **EAGLE** uses these commands to configure and display the **OAP** data in the database and send this data to the **OAP**. Refer to the *Commands Manual* for current usage information.

- `chg-oap-config`
- `chg-oap-lkeys`
- `act-oap-config`
- `rtrv-oap-config`

This feature can be used to configure and update the Texas Micro **OAPs** currently being used or the Embedded **OAPs** introduced in Release 24.0. This feature cannot be used to upgrade the **OAP** software. Upgrading the **OAP** software must be performed by a terminal connected directly to the **OAP**.

CHG-OAP-CONFIG

The `chg-oap-config` command is used to configure the **EAGLE** database with the **OAP** configuration information. This information is sent to the specified **OAP** with the `act-oap-config` command.

CHG-OAP-LKEYS

The `chg-oap-lkeys` command is used to enter the license keys of the **DSET APLI**, **DSET DSGRuntime**, Solstice **OSI**, and Solstice X.25 third party **OAP** software into the **EAGLE** database. The license keys are not sent to the **OAP** with the `act-oap-config` command, but are used when auditing the **OAP** and **EAGLE** configuration data.

ACT-OAP-CONFIG

The `act-oap-config` command is used to update the **OAPs** with the configuration data entered into the **EAGLE** database with the `chg-oap-config` command.

RTRV-OAP-CONFIG

This command displays the **OAP** configuration information in the **EAGLE** database that has been configured with the `chg-oap-config` and `chg-oap-lkeys` commands.

CHG-SID

When the **EAGLE's CLLI** has been entered into the database or changed with the `chg-sid` command, the **OAP** configuration must be changed to include the new **CLLI** value. When this change to the **EAGLE's CLLI** has been made, the following warning message is displayed in the scroll area of the terminal display, reminding the user that the **OAP** configuration must be updated with the `act-oap-config` command.

LNP Service Commands

When the **LNP** feature is on, the **LNP** services **CLASS**, **CNAM**, **LIDB**, and **ISVM** must be in the **OAP** configuration in the **EAGLE** database. When these services are added to the database (with the `ent-lnp-serv` command), removed from the database with the `dlt-lnp-serv` command, or changed with the `chg-lnp-serv` command, the **OAP** configuration must be updated with the `act-oap-config` command. When any of these changes to the **LNP** services have been made, the following warning message is displayed in the scroll area of the terminal display, reminding the user that the **OAP** configuration must be updated with the `act-oap-config` command.

Auditing the OAP Database

In order to keep **OAP** database synchronized with the **EAGLE**, a checksum is created using all of the **OAP** configuration data stored on the **EAGLE**. The **OAP** also calculates this checksum based on the data it has. This checksum is returned by the **OAP** with every forced maintenance poll allowing the **EAGLE** to compare and act on the result. If the checksum values do not agree, the **EAGLE** generates a minor alarm (**UAM 0364**) within 10 seconds:

UAM 0364 is cleared within five seconds after the **EAGLE** detects that the databases are synchronized again, and the checksum values of the databases agree, with **UAM 0365**:

2.138 EAGLE Measurement Reports (Release 20.0)

EAGLE STP measurements provide support for **STP** performance management, **SS7** traffic monitoring and engineering, and Specific feature performance analysis (**STPLAN**).

Refer to the *Maintenance Manual* for current **EAGLE** measurement information.

2.139 EAGLE MNP Data Base support for 240M DN (Release 46.3)

This feature expands the capacity of the EPAP and EAGLE Data Base to support 240M individual DN entries, 240M individual IMSI entries and 48 million individual IMEI entries.

If the EPAP Split DB feature is OFF, then the DN & IMSI tables are loaded onto a single EPAP card. In this case, the DN + IMSI entries must be less than 240 million. The following table shows capacity combinations:

Table 2-31 EAGLE Feature and EPAP DB Capacity Combinations

EPAP Split DB Feature	STPOPTS: EPAP240M	Max Individual DNs	Max Individual IMSIs	Max Individual DNs + Individual IMSIs	Max Individual IMEIs	E5-SM4G Allowed
OFF	OFF	120M	120M	120M	32M	Yes
ON	OFF	120M	120M	240M	32M	Yes
OFF	ON	240M	240M	240M	48M	No
ON	ON	240M	240M	480M	48M	No

To enable the 240M DN & 240M IMSI + 48M IMEI capacity expansion on EAGLE, a new parameter `EPAP240M` is introduced in the STPOPTS table. The E5-SM8G-B cards on EAGLE are able to load more than 120M DN entries only when the `STPOPTS: EPAP240M` parameter is ON.

2.139.1 Hardware

The EAGLE MNP Data Base support for 240M DN feature is supported on E5-SM8G-B cards.

This feature has a dependency on 64-bit GPLs. The E5-SM8G-B cards must be running 64-bit GPLs in order to support the larger RTDB data from the EPAP. If the E5-SM8G-B cards are not already running 64-bit GPLs, then the flash GPLs on the E5-SM8G-B cards need to be manually converted to 64-bit. Refer to the Notes section for the init-flash command in *Commands User's Guide* for detailed instructions for converting to 64-bit GPLs.

E5-SM4G cards are unable to load more than 120M DN or 120M IMSI entries. If E5-SM4G cards in the EAGLE system are in IS-NR/ACTIVE state, the `STPOPTS: EPAP240M` option will not be turned ON. If `STPOPTS: EPAP240M` is ON, the E5-SM4G cards will be auto-inhibited if present or hot-swapped with E5-SM8G-B cards.

2.140 EAGLE OA&M IP Security Enhancements (EAGLE Releases 30.0, 30.2, IP7 Secure Gateway Release 8.0)

Description

The **EAGLE OA&M IP Security Enhancements** feature provides tools to securely pass data across an otherwise non-secure network. Once the **EAGLE OA&M IP Security Enhancements** Feature is turned on, the **EAGLE** allows only secure connections from approved clients, and protects sensitive passwords and information while in transit between the **EAGLE** and a host.

The **EAGLE OA&M IP Security Enhancements** feature uses a software package called **Secure Shell**. **Secure Shell (SSH)** is a protocol for secure remote login and other network services over an insecure network. **SSH** encrypts and authenticates all **EAGLE IPUi** traffic, incoming and outgoing (including passwords) to effectively eliminate eavesdropping, connection hijacking, and other network-level attacks.

SSH consists of several component applications, two of which are relevant for **IPUI** enhancements: **SSH** client program for secure remote login (an enhancement for telnet), and **SFTP**, the secure file transfer protocol (which replaces **FTP**); refer to the **bold** components in the following figure.

Figure 2-16 The Secure Shell Package

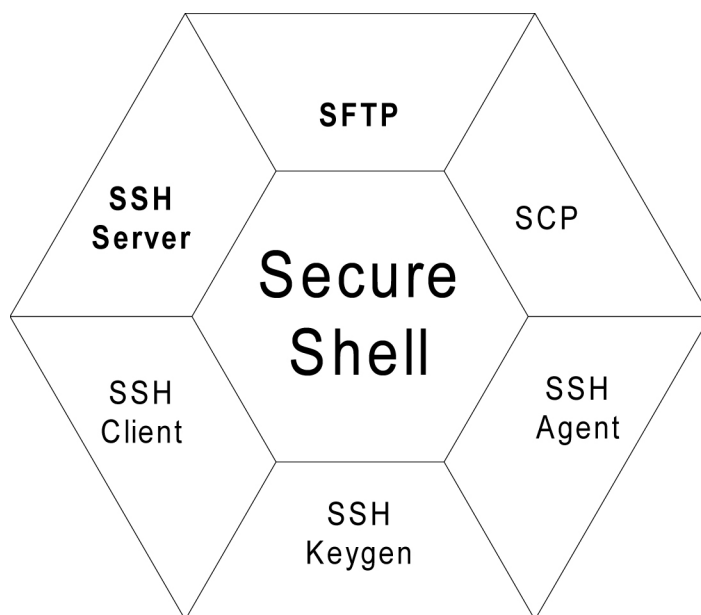

Both applications support strong encryption of passwords and data, using widely accepted cipher routines. In addition, they provide authentication to reliably determine the source of any connection attempt. Lastly, **SSH** provides a guarantee of data integrity, which ensures data cannot be tampered with, even while in transit over the network. These security features, once implemented, are transparent to the users.

IP Network Security

A non-secure network is vulnerable to several types of electronic attacks. **IP** protocol itself provides limited inherent capability for confidentiality or security. Because of this, networks that depend on **IP** are subject to relatively simple attacks; these include eavesdropping on an **IP** transmission, recording or even modifying data. A protocol analyzer, for instance, can record network traffic, and then the packet's data contents are open to view. Another type of **IP** attack involves a third-party taking over a session and masquerading as one of the original parties involved in the communication.

IP-based security vulnerabilities include:

- *Snooping*, or eavesdropping on a connection, which is especially damaging while passwords are being transmitted (see next figure).

Figure 2-17 Example of Snooping

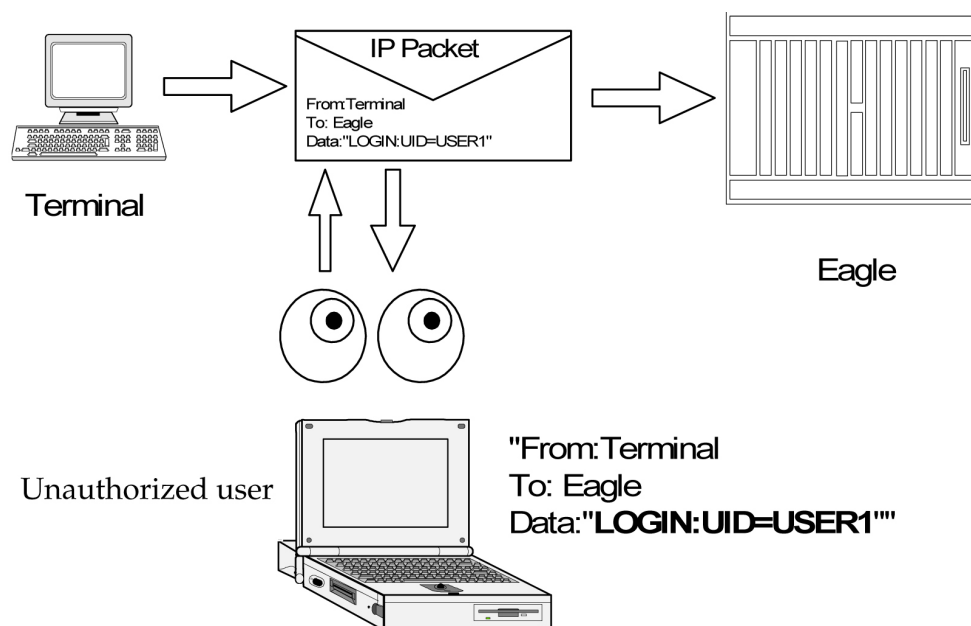

- **IP spoofing**, in which an intruder tries to gain access by changing a packet's IP address to make it appear that the packet came from another, trusted host (see next figure).

Figure 2-18 Example of Spoofing

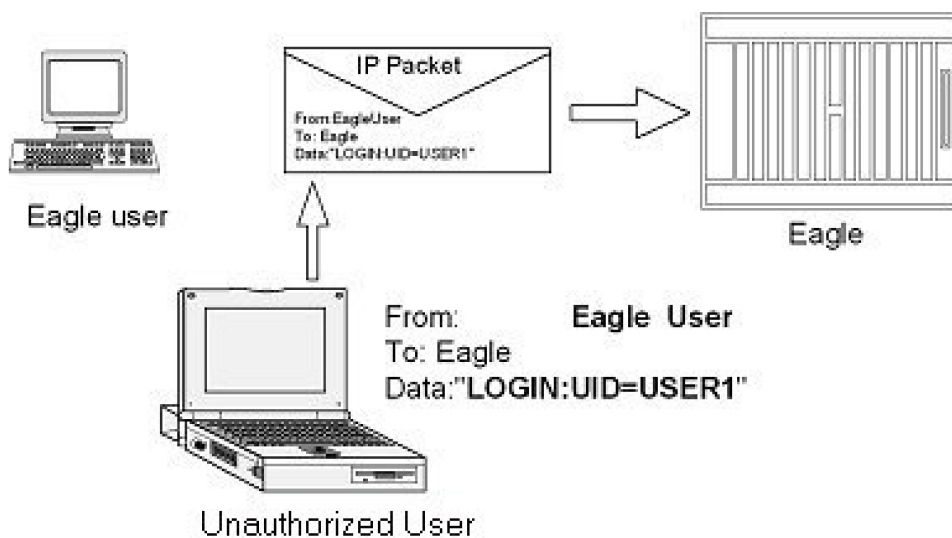

- **IP source routing**, where a host can pretend that an IP packet comes from another, trusted host
- **DNS spoofing**, where an attacker forges name server records
- Interception of clear text passwords and other data by intermediate hosts
- Manipulation of data by people in control of intermediate hosts
- Attacks based on listening to authentication data and spoofed connection to the server.

Addressing IP Security

The **EAGLE Secure Shell** package developed for this feature addresses the network vulnerabilities as follows:

Identification

Identification occurs on many levels during a telnet or **FTP** terminal session. User identification is not only via username, but also through the originating **IP** address, and also by the **Secure Shell** client session **ID**. During the establishment of a secure connection, the host and client go through a process of key exchange and verification, to firmly establish a session identity. **Secure Shell** is in effect, providing a secure pipe between the client and host for the duration of that connection. All subsequent messages can be verified as originating from that known and established source.

Authentication

Authentication, at the user level, is provided for by the **EAGLE** login (username and password). This establishes the users identity. **Secure Shell** provides for authentication at the message level, to ensure incoming messages have originated from a known and verified source, while the session is in effect. This prevents network attacks based on spoofing or modifying the **IP** packets addressing headers, or originator **ID**.

Confidentiality

Confidentiality is enforced via message encryption. The **Secure Shell** tools encrypt each packet of data, before being exchanged in the process of either file transfer, or an interactive session. This encryption prevents snooping-type **LAN** attacks, where a hostile party intercepts and attempt to read messages in transit.

Data Integrity

Encryption also protects the data contained in the message or the message header from being altered or modified (either maliciously or accidentally) while in transit. Any message that fails an integrity test would be discarded, and the protocol would request the originator to resend the lost message. Data integrity is protected by including a Message Authentication Code (**MAC**) with each packet. The **MAC** is computed from a shared secret (key), packet sequence number, and the contents of the packet. The message authentication algorithm and key are negotiated when the connection is established.

Encryption

The secure connection and data encryption is established *before* the password or other authentication is ever sent, so all data remains protected. The client determines the encryption cipher; one of several is used, such as 3DES, **IDEA**, or Blowfish. Once the cipher has been determined (generally within the client preferences), the client and server exchange encryption keys.

Strong Authentication

Strong authentication on a per-user basis would entail the use of public/private key pairs, generated at runtime and distributed to each user's client, along with a pass code that was user specific. These keys could not be pre-generated and stored in a table (with user names and passwords), since that would compromise any security advantage they were meant to impart. This would also entail an administrator account on each **IPSM** or **MCPM** card, along with a key server agent, to track user keys. Neither the **IPSM** nor **MCPM** platform currently supports administrator shell access, or a file system to store keys generated at runtime. This feature does not address Strong Authentication.

Secure Shell Summary

The top drawing in the following figure depicts a standard **IP** packet traveling over a **LAN** connection to the server. A packet header contains the destination address, the sender's address, etc. The packet contains data. An **IP** sniffer could open this packet from the **IP** stream, examine the contents, change the source or destination address, or change the contents. Security tools prevent the originator's address from being altered, the destination address from being altered, and the data is both unreadable, and protected from modification while in transit.

Figure 2-19 IP Network Security

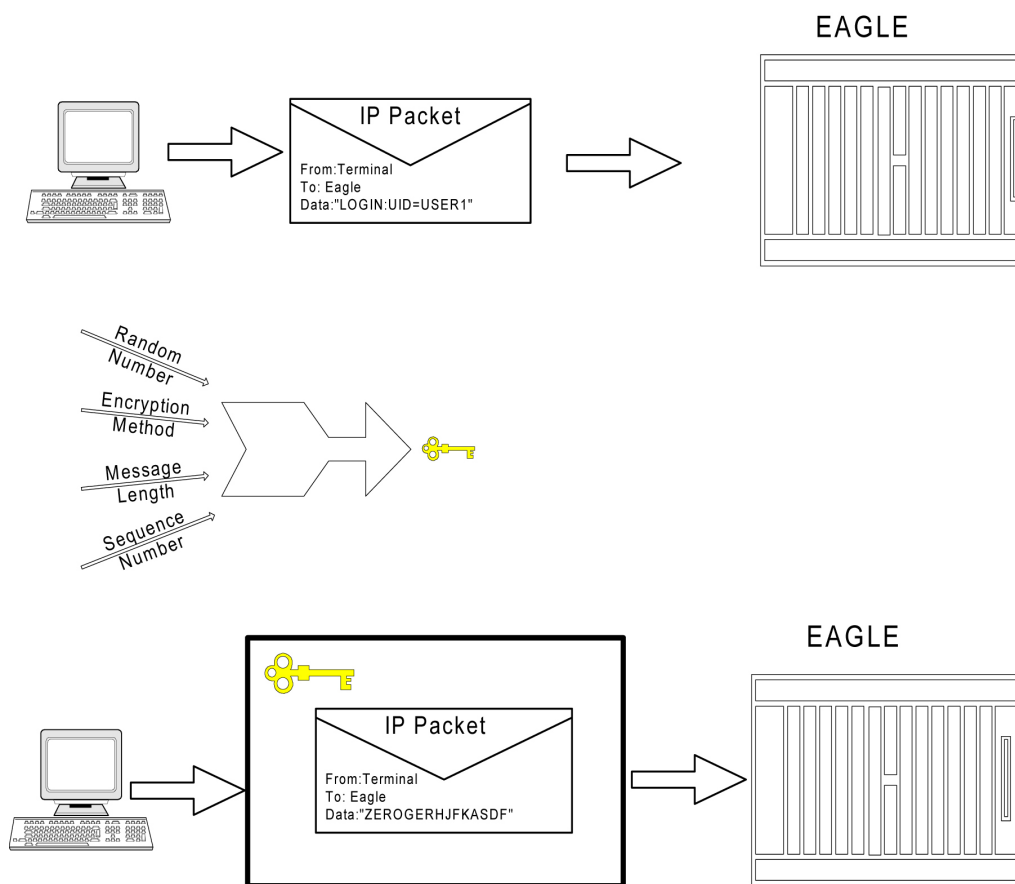

EAGLE Secure Shell Solution

The **EAGLE** communicates over **IP** using two methods: Telnet and File Transfer. Telnet is the remote interactive terminal session. **FTP** Retrieve and Replace and Measurements Platform use file transfer, for performing bulk data transfer to remote servers.

Secure Shell uses encryption and authentication to protect sensitive data as it passes from one system to another in either scenario. **SSH**, a terminal connection program, and **SFTP**, a file transfer program, use an encryption algorithm for protecting all data transmitted over a session, including initial login and password, files and commands sessions.

All data passed through a **Secure Shell** session is secure: **Secure Shell** encrypts and authenticates all traffic, incoming and outgoing (including passwords) to effectively eliminate eavesdropping, connection hijacking, and other network-level attacks.

Secure Shell works through three fundamental stages:

- **Integrity** - Guarantees the data traveling over a network arrives unaltered.
- **Encryption** - Scrambles data to render it unintelligible, except to the intended recipients. A network sniffer could not read the enclosed data, as it cannot be decrypted without the key.
- **Authentication** - A secure protocol authenticates the source and destination addresses, as well as encrypts and data contained. Authentication protects against several security problems, e.g., **IP** spoofing, fakes routes, and **DNS** spoofing. Nor could false data be substituted, since authentication would reject any but known client's packets.

Applying Secure Shell to EAGLE

This feature applies **Secure Shell** Version 2.0 to **EAGLE OA&M IP** Interfaces. **Secure Shell** defines a protocol for secure remote login and other secure network services over any non-secure network. It provides an encrypted terminal session with authentication of both the server and client. It provides authentication and secure communications over unsecured channels. In other words, **Secure Shell** never trusts the net; somebody hostile who has taken over the network can only force **Secure Shell** to disconnect, but cannot decrypt or play back the traffic, or hijack the connection. **Secure Shell** contains two separate utilities for **IP OA&M** connections: **SSH** and **SFTP**.

- **SSH** is the terminal session utility of the **Secure Shell** package. **SSH** is a secure replacement for telnet clients.
- **SFTP** is the file transfer utility that is part of the **Secure Shell** package.

SSH and **SFTP** share the same security features, which include:

- A variety of data authentication methods.
- A secure session established between clients and hosts.
- Support for data encryption.

EAGLE IP Features

The **EAGLE OA&M IP** Security Enhancements feature affects these features:

- **IPUI** User Interface (Telnet), introduced in **EAGLE** Release 29.0/**IP**⁷ Secure Gateway Release 7.0
- **FTP** Retrieve and Replace, introduced in **EAGLE** Release 29.0/**IP**⁷ Secure Gateway Release 7.0
- Measurements Platform (**EAGLE** Release 28.0)

Hardware Requirements

No new hardware is needed to support this feature.

Upgrade Considerations

FTRA (**FTP**-based Table Retrieve Application) software must be upgraded to support the **EAGLE OA&M IP** Security Enhancements feature.

Limitations

Security is a process, not a product. **EAGLE OA&M IP** Security Enhancements will not assist any activity that compromises a host's security in some other way. This feature provides secure access to the **EAGLE IPUI** terminals, and while the **EAGLE** is transferring data off-board to remote **SFTP** servers. Vigilance still is required in protecting username/password combinations, and in controlling system access to **EAGLE** commands (via the configurable command class feature) to prevent violation of access privilege. This feature does not provide the remote **Secure Shell** client or server applications (**SSH**, **SFTP**).

If this feature is enabled with a temporary key, the key can expire while telnet (**SSH**) or **FTP (SFTP)** connections are up and in progress. In this scenario, all existing (legacy) connections remain up, and new connections follow the state of the feature: **ON** or **OFF**. Both secure and non-secure connections are possible for the duration of the 'legacy' connection.

2.141 EAGLE OA&M Password Security Enhancements (Release 42.0)

The EAGLE OA&M Password Security Enhancements feature increases the security measures used by the EAGLE 5 ISS Password Management facility.

New Security Measures:

- More restrictive password measures
- Prevention of password re-use
- Prevention of bypassing password re-use rules
- Prevention of a common password pattern
- Access to the EAGLE 5 ISS for a specified period without requiring a password change
- Enhanced notification to the user that passwords have expired or are about to expire

2.141.1 Feature Control Requirements

The EAGLE OA&M IP Security Enhancements feature (Part Number 893-4000-01) must be turned on before passwords can be created or modified from a Telnet terminal (terminal IDs 17 - 40). If the feature is not turned on, then passwords must be created or modified from a Serial terminal (terminal IDs 1 - 16).

2.142 EAGLE - Obsolete OAM Measurements (Release 46.3)

This enhancement removes the support of OAM Measurements and FTA Zone. From EAGLE 46.3 and later, basic OAM measurements are not supported. For measurement collection to happen, either the Integrated Measurements Feature (`ctrl-feat`) or MCPM Based Collection Feature (`measplat=on`) should be enabled.

2.143 EAGLE Support for Integrated Sentinel (Release 28.0)

Description

The **EAGLE STP** and the Sentinel Network Maintenance and Diagnostics tool are both existing Tekelec products. Without the **EAGLE Support for Integrated Sentinel** feature, the Sentinel requires physical, clamp-on connections to the **EAGLE's SS7** signaling links, in order to monitor **SS7** traffic. This monitoring method involves costs for cable installation and maintenance for each **SS7** link that is to be monitored.

The **EAGLE Support for Integrated Sentinel** feature eliminates the need for intrusive hardware for each link to be monitored; instead, monitoring is via an Ethernet connection. Message Signaling Units (**MSUs**), alarms and events can be copied to the **ESP** over the Ethernet link to provide the same network traffic monitoring.

For more information on the **EAGLE Support for Integrated Sentinel** feature, refer to the **Database Administration Manual - Features**.

Hardware Requirements

The **EAGLE Support for Integrated Sentinel** feature requires **GPSM-II** cards in place of **MCAP** cards. Also, the **EAGLE Time Synchronization feature (TSC Sync)** must be active in conjunction with this feature. In addition, the timing requirements include the use of an external nits clock.

Caution:

The **EAGLE Support for Integrated Sentinel** feature also requires the **STC** cards (870-1945-xx) and **HMUX** (870-1965-01 Rev A). For **EAGLE 28.0**, **DCM** cards (870-1945-xx) will serve as **STC** cards.

Note:

The **TSC** feature requires **GPSM-II**; the **EAGLE Support for Integrated Sentinel** feature requires the **TSC** feature.

For detailed hardware information, refer to the **NSD Hardware Manual**.

2.144 EAGLE Query Server on COTS Hardware (Release 1.0)

The EAGLE Query Server is developed and deployed on commercial off the shelf (COTS) hardware platform.

The EAGLE Query Server is compatible with version 6.7 or later of the x86-64 Red Hat Enterprise Linux 6 (RHEL)/ Oracle Linux Operating System.

2.144.1 Hardware

The EAGLE Query Server is installed on a virtual machine environment. The Master and Slave EAGLE QS supports the following minimum hardware requirements:

Table 2-32 Hardware Setup Detail

Server Type	OS	Release	Arch	Processor	Number of Core	Available Disk Space for Application	Memory Size
VM	Oracle Linux/RHEL	6.7 or later	X86_64	Intel® Xeon® CPU L5410 @2.33GHz	16	500 GB	16 GB

2.145 EAGLE Query Server Support EPAP (Release 1.0)

This feature enhances the current EPAP architecture and performance through an external query server, providing offline query support for EPAP databases. This feature offers standard query interfaces, including SQL and access to MNP data.

The Provisionable EPAP (either Active or Standby PDB) is able to connect to one "master" EAGLE Query Server. The Provisionable EPAP can be either Standalone PDB or Mixed EPAP.

See *Query Server User's Guide* for more information.

2.146 EDCM Support (IP⁷ Release 4.0)

As the **IP⁷ SG** applications add new features and their throughput increases, more memory storage and **CPU** performance is required from the hardware platform. The Enhanced-Performance **DCM (EDCM)** is a new version of the **DCM** that includes more main memory and better processing performance. Additional memory is added, doubling the amount of application **SRAM**. Some memory is replaced with higher performance chips. The following list highlights the changes embodied by the **EDCM**:

- The application processor is the **AMD K6-IIIe+**, which is an embedded version of the **AMD K6-III** high-performance processor that is used on the **DCM 870-1945-xx**. This processor consumes less power and produces less heat, leading to increased reliability.
- The application processor operates with an internal clock frequency of 396MHz rather than the 298MHz of the **DCM**, thereby increasing application performance and reliability.

The following elements of the **EDCM** are unchanged from the **DCM**:

- The **EDCM** requires two frame slots, like the **DCM**.
- The communication processor is unchanged.

- The amount of communication processor main memory is unchanged (2MB).

Refer to the **NSD Hardware Manual** for current hardware information.

2.147 EIR Expansion 50K to 100K (Release 45.0)

The EIR Expansion 50K to 100K feature expands the EIR Block capacity to allow storage of 100,000 IMEI range entries in the Range IMEI Tables. A single EIR range can be present in multiple lists. For example, one range can be in both BL (Blacklist) and WL (Whitelist).

2.148 EIR Expansion of IMEI Block from 50k to 100k (EPAP 15.0)

The IMEI Block capacity for Equipment Identity Register (EIR) is expanded from 50,000 to 100,000 entries. This feature must be turned on at both the EAGLE and the EPAP. As a permanently-on feature, the feature cannot be turned off after it is turned on. The capacity of the IMEI Range entries in the IMEI Range Tables remains 50,000. A single EIR IMEI Range can be present in multiple lists. For example, an IMEI Range can be in both Black List (BL) and White List (WL).

2.149 EIR S13/S13' Interface Support (Release 45.1)

Equipment Identity Register (EIR) is a database containing records of all mobile stations that are allowed or banned in a network. Generally, the banned mobile stations have been declared lost or stolen. Each mobile station is identified by its International Mobile Equipment Identity (IMEI). When a mobile station is detected by the network, the Mobility Management Entity (MME) or Serving GPRS Support Node (SGSN) requests the IMEI of the mobile station, which is sent to the EIR for authorization.

The EIR S13/S13' Interface Support feature allows EIR to support the S13 and S13' Diameter interfaces for these messages. By supporting the S13/S13' interfaces, Diameter requests can be received by an EAGLE card and processed by EIR, and then a response transmitted back to the requester.

2.149.1 Feature Control Requirements

- The feature Part Number is 893-0424-01.
- A temporary Feature Access Key (FAK) cannot be used to enable the feature.
- The feature cannot be turned off after it is turned on.
- The feature appears as `S13/S13' Int for EIR` in the `rtrv-ctrl-feat` output.

2.149.2 Hardware Requirements

- The E5-SM8G-B card is the only Service Module card which supports the DEIRHC application for the EIR S13/S13' Interface Support feature.
- A maximum of 16 E5-SM8G-B cards running the DEIRHC application can be configured in one EAGLE 5.
- A maximum of 32 Service Module cards running a combination of the SCCPHC, SIPHC, and DEIRHC applications can be configured in one EAGLE 5.

2.150 ELAP Backup Enhancements (ELAP 10.0)

The ELAP Backup Enhancements feature allows users to schedule customized automatic ELAP RTDB backups based on their individual needs. Currently, automatic ELAP RTDB backups are scheduled for 6:00 AM daily in the Active Server. For many users, 6:00 AM is outside their normal maintenance windows or off-peak provisioning hours.

The ELAP Backup Enhancements feature allows users to schedule automatic ELAP RTDB backups using the **Maintenance**, and then **Automatic RTDB Backup** menu option of the ELAP GUI on the Active ELAP server only. The **Automatic RTDB Backup** menu option is available after initial installation and does not require feature activation. Only the *elapdev* user can execute the action in the cron entry.

Figure 2-20 Automatic RTDB Backup Menu Option

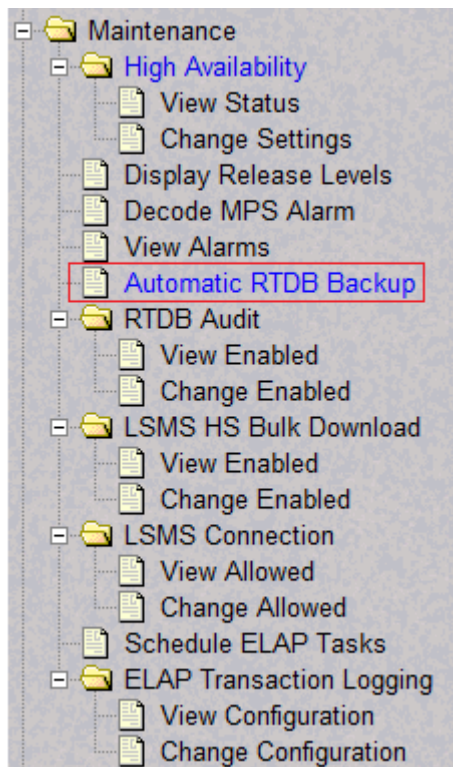

After selecting the **Automatic RTDB Backup** menu option, the screen shown in [Figure 2-21](#) is displayed to configure the Automatic RTDB Backup schedule. Refer to *ELAP Administration and LNP Feature Activation* for additional information about the configuration options.

Figure 2-21 Automatic RTDB Backup screen

ELAP_A_NAME		Automatic RTDB Backup
Backup Type (Select None to Cancel Backups)	Local and Mate	
Time of the day to start the Backup	6:00	
Frequency	1 Day	
File Path (Directory only)		
Remote Machine IP Address (xxx.yyy.zzz.yyy)		
Login Name		
Password		
Save the local copies in the default path	<input type="radio"/> Yes <input type="radio"/> No	
Option to delete old backups Note: If you select Yes, by default 5 backup files will be maintained	<input checked="" type="radio"/> Yes <input type="radio"/> No	
Specify the number of files to maintain	5	
<input type="button" value="Submit Schedule"/>		

2.151 ELAP Logging Enhancements (ELAP 10.0)

The ELAP Logging Enhancements feature moves the existing logging function from the LSMS to each ELAP server to maintain logging history for LNP provisioning records, while offering more distributed log architecture. Moving the logging function from the LSMS to the ELAP servers also provides more storage capability (approximately 40 GB) which allows for logs to be retained for a longer period.

The ELAP Logging Enhancements feature can be set to *on* or *off*. When the ELAP Logging Enhancements feature is *on*, provisioning of LNP transactions are logged on the ELAP server. The initial status of the feature is *off*.

The ELAP Logging Enhancements feature is configured from the **Change Configuration** selection under the **Maintenance**, and then **ELAP Transaction Logging** menu option of the ELAP GUI for the Active ELAP server only. An example screen displayed after selecting **Change Configuration** is shown in [Figure 2-23](#). The Remote system fields can be accessed only when Log files export to remote machine is set to *Enabled*. Refer to *ELAP Administration and LNP Feature Activation* for additional information about the configuration options.

Figure 2-22 ELAP Transaction Logging Menu Option

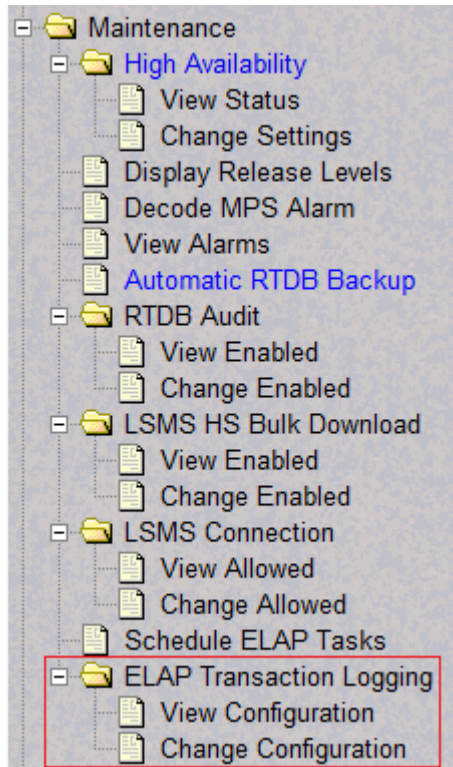

Figure 2-23 Change Configuration (Logging feature = On; Log files export to remote machine = Enabled)

ELAP_A_NAME Change ELAP Transaction Logging Configuration

ELAP Logging Enhancements Feature:	<input checked="" type="radio"/> On	<input type="radio"/> Off
Time Format:	<input type="radio"/> UTC	<input checked="" type="radio"/> System Defined
Log files export to remote machine:	<input checked="" type="radio"/> Enabled	<input type="radio"/> Disabled
Remote system IP address:	<input type="text" value="10.248.15.12"/>	
Remote system user name:	<input type="text" value="root"/>	
Remote system password:	<input type="password" value="••••••"/>	
Remote system sftp location:	<input type="text" value="/var/tmp"/>	

From the **Maintenance**, and then **ELAP Transaction Logging** menu option, the **View Configuration** selection displays the current configuration. The configuration determines which properties are displayed.

Figure 2-24 ELAP Logging Enhancements Feature = OFF

ELAP_A_NAME View ELAP Transaction Logging Configuration

ELAP Logging Enhancements Feature:	Off
------------------------------------	-----

Figure 2-25 ELAP Logging Enhancements Feature = ON; Log files export to remote machine = Disabled

ELAP_A_NAME View ELAP Transaction Logging Configuration

ELAP Logging Enhancements Feature:	On
Time Format:	UTC
Log files export to remote machine:	Disabled

Figure 2-26 ELAP Logging Enhancements Feature = ON; Log files export to remote machine = Enabled

ELAP_A_NAME View ELAP Transaction Logging Configuration

ELAP Logging Enhancements Feature:	On
Time Format:	System Defined
Log files export to remote machine:	Enabled
Remote system IP address:	10.248.15.12
Remote system user name:	root
Remote system sftp location:	/var/tmp

In addition, the **Debug** menu of ELAP GUI for the Active ELAP server has a new option **LNPTRANS** under **View Logs**. Selecting this option allows the user to view the latest LNPTRANS logs.

2.152 ELAP Network Address Translation (NAT) (EAGLE Release 30.0/IP7 Secure Gateway Release 8.0)



Note:

The **ELAP NAT** feature is only available at the preproduction level.

Description

Customers need to support communication between an **ELAP** system and a remote browser that may be on the public side of an **IP** firewall or router that employs Network Address Translation (**NAT**).

With the **ELAP** Network Address Translation (**NAT**) feature, the **MPS** platform (**ELAP/EPAP**) supports communications on networks where Network Address Translation (**NAT**) is employed. This means that the two **MPS** systems (A and B) can intercommunicate using **IP** addresses on a private network, yet also support **IP** addressing and communication with a remote browser that may be on the public or "other" side of a firewall or router employing **NAT** that is performing the **IP** address translation.

Network Address Translation (NAT) on MPS

The **MPS** supports two types of network address translation (**NAT**), Port Forwarding and Static Address Mapping. In both cases, the **MPS** will have private **IP** addresses that are not available outside of the firewall-protected internal network. The firewall will translate particular addresses and port numbers to the internal addresses for the **MPS**.

The addresses in the following figure are examples. Addresses are not restricted to particular classes/ranges.

Figure 2-27 Network Address Translation on MPS

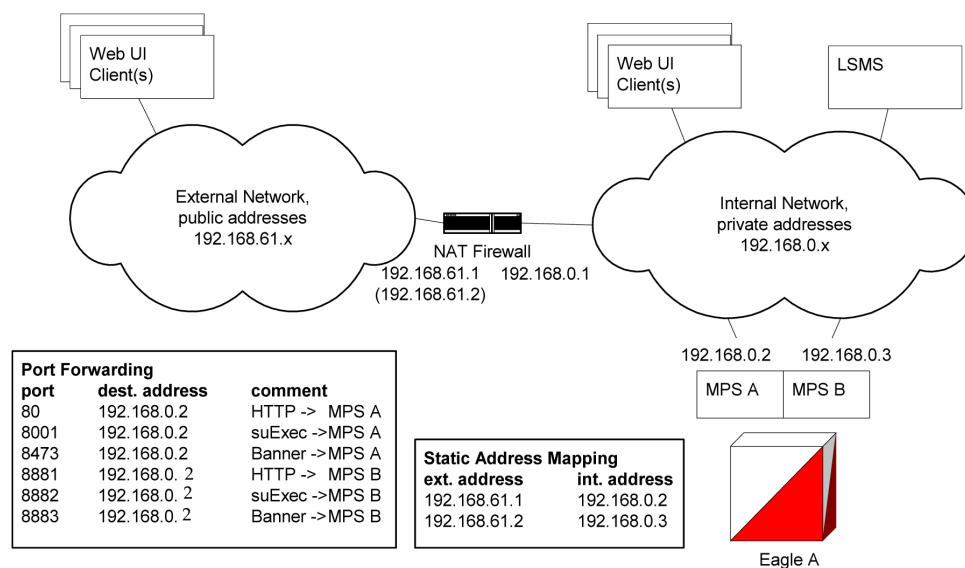

Port Forwarding

Port forwarding allows a single external address to be used for multiple internal systems. The port forwarding firewall maintains a list of services (basically port numbers) and corresponding internal addresses.

Although the **MPS** has two individual internal **IP** addresses, external clients are only allowed to reach the internal network using one external address. The **MPS** servers

must use different port numbers for each externally available service in order to distinguish **MPS A** from **MPS B** to external clients.

 **Caution:**

Do not change the default values for these ports.

Static Address Mapping

Static address mapping makes systems that are behind the firewall appear to have public addresses on the external network. A one-to-one mapping exists between internal and external addresses.

An external address must be assigned to the **NAT** firewall for each **MPS** side. For the Web **UI** to be fully functional, the external addresses must be entered into the **MPS** database.

Hardware Requirements

No new or additional hardware is required to support this feature.

Enhancements to the ELAP Text-Based Interface

This section describes the enhancements to the text-based **ELAP** Configuration interface made to accommodate this feature. For more information, see the ***ELAP Administration Manual***.

ELAP Configuration Menu

Entering '1' from the **ELAP** Configuration Menu provides a configuration report of the **ELAP**. The following figure illustrates an example configuration that includes **NAT** Address information (see arrows):

Figure 2-28 Display Configuration

```

MPS Side A:  hostname: mpsa-dlc48f  hostid: 80dlc48f
              Platform Version: 3.0.0-22.13.0
              Software Version: ELAP 3.0.0-30.19.0
              Mon Dec 16 16:42:32 EST 2002

ELAP A Provisioning Network IP Address = 192.168.61.90
ELAP B Provisioning Network IP Address = 192.168.61.91
Provisioning Network Netmask          = 255.255.255.0
Provisioning Network Default Router   = 192.168.61.250
ELAP A Backup Prov Network IP Address = Not configured
ELAP B Backup Prov Network IP Address = Not configured
Backup Prov Network Netmask          = Not configured
Backup Prov Network Default Router    = Not configured
ELAP A Sync Network Address          = 192.168.2.100
ELAP B Sync Network Address          = 192.168.2.200
ELAP A Main DSM Network Address      = 192.168.128.100
ELAP B Main DSM Network Address      = 192.168.128.200
ELAP A Backup DSM Network Address    = 192.168.129.100
ELAP B Backup DSM Network Address    = 192.168.129.200
ELAP A HTTP Port                     = 8888
ELAP B HTTP Port                     = 80
ELAP A HTTP SuExec Port              = 8001
ELAP B HTTP SuExec Port              = 8001
ELAP A Banner Connection Port        = 8473
ELAP B Banner Connection Port        = 8473
ELAP A Static NAT Address             = 10.25.50.10 ←
ELAP B Static NAT Address             = 10.25.50.11 ←
ELAP A LSMS Connection Port          = 7402
ELAP B LSMS Connection Port          = 7403
ELAP A EBDA Connection Port          = 1030
ELAP B EBDA Connection Port          = 1030
Time Zone                             = US/Eastern

Press return to continue...

```

Configure Network Interfaces Menu

This menu allows for the configuration of all of the possible network interfaces for the **ELAP**. When this menu item is selected, the menu shown in the following figure is displayed (see arrows).

Figure 2-29 Configure Network Interfaces Menu

```

/-----Configure Network Interfaces Menu-----\
|-----|-----|-----|-----|-----|-----|
| 1 | Configure Provisioning Network | | | | |
|---|---|---|---|---|---|
| 2 | Configure Sync Network |
|-----|-----|-----|-----|-----|-----|
| 3 | Configure DSM Network |
|-----|-----|-----|-----|-----|-----|
| 4 | Configure Backup Provisioning Network |
|-----|-----|-----|-----|-----|-----|
| 5 | Configure Forwarded Ports |
|-----|-----|-----|-----|-----|-----|
| 6 | Configure Static NAT Addresses |
|-----|-----|-----|-----|-----|-----|
| e | Exit |
|-----|-----|-----|-----|-----|-----|
\-----/

```

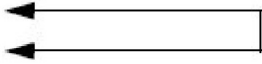
Configure Forwarded Ports

Entering a choice of '5' from the Configure Network Interfaces Menu provides the functionality to configure **ELAP** ports for the Web **UI** and **PDBI** interfaces. When this menu item is selected, the menu shown in the following figure is displayed.

Figure 2-30 Configure Forwarded Ports Menu

```

/-----Configure Forwarded Ports Menu-----\
|-----|-----|-----|-----|-----|-----|
| 1 | Change ELAP A HTTP Port | | | | |
|---|---|---|---|---|---|
| 2 | Change ELAP B HTTP Port |
|-----|-----|-----|-----|-----|-----|
| 3 | Change ELAP A HTTP SuExec Port |
|-----|-----|-----|-----|-----|-----|
| 4 | Change ELAP B HTTP SuExec Port |
|-----|-----|-----|-----|-----|-----|
| 5 | Change ELAP A Banner Connection Port |
|-----|-----|-----|-----|-----|-----|
| 6 | Change ELAP B Banner Connection Port |
|-----|-----|-----|-----|-----|-----|
| 7 | Change ELAP A LSMS Connection Port |
|-----|-----|-----|-----|-----|-----|
| 8 | Change ELAP B LSMS Connection Port |
|-----|-----|-----|-----|-----|-----|
| 9 | Change ELAP A EBDA Connection Port |
|-----|-----|-----|-----|-----|-----|
|10 | Change ELAP B EBDA Connection Port |
|-----|-----|-----|-----|-----|-----|
| e | Exit |
|-----|-----|-----|-----|-----|-----|
\-----/

```

Each numbered item on the Configure Forwarded Ports menu allows the user to specify a port number used for remote access to the **MPS**.

Configure Static NAT Addresses

Entering a choice of '6' from the Configure Network Interfaces Menu provides the functionality to configure the static **NAT** addresses of the **ELAP**. When this menu item is selected, the menu shown in the following figure is displayed.

Figure 2-31 Configure Static NAT Addresses Menu

```

/-----Configure Static NAT Addresses Menu-----\
| 1 | Change ELAP A Static NAT Address              |
|-----|-----|
| 2 | Change ELAP B Static NAT Address              |
|-----|-----|
| e | Exit                                          |
\-----/

```

Each numbered item of the Configure Static **NAT** Addresses menu allows the user to specify an **IP Address** used outside of the firewall for remote access to the **MPS**. The values entered here must match the configuration of the firewall.

2.153 ELAP Support for more than Nine E5-SM4G Cards for the LNP Feature (ELAP 9.0)

ELAP has been updated to support the connection to and loading of more than 9 and up to 18 **E5-SM4G** Service Module cards on the EAGLE 5 ISS with the **LNP** feature.

The additional E5-SM4G cards can increase system transmissions per second (**TPS**) as follows:

- With the EAGLE 5 ISS E5-SM4G Throughput Capacity feature quantity of 5000 TPS enabled, the system TPS for 17+1 E5-SM4G cards in the EAGLE 5 ISS is 85,000 TPS.
- With the EAGLE 5 ISS E5-SM4G Throughput Capacity feature quantity of 6800 TPS enabled, the system TPS for 17+1 E5-SM4G cards in the EAGLE 5 ISS is 115,600 TPS.

Refer to *ELAP Administration Manual - 9.0* of the EAGLE 5 ISS Release 42.0 documentation set for more information.

2.153.1 Feature Control Requirements

To support more than 9 E5-SM4G cards in the EAGLE 5 ISS system, the following feature control is required:

- The LSMS, EAGLE 5 ISS, and ELAP systems must be running at the required release levels:

- LSMS 12.0
- EAGLE 5 ISS 42.0
- ELAP 9.0
- The LNP feature must be enabled

2.154 ENUM Mobile Number Portability and Tier One Address Resolution (Release 46.2)

The ENUM Mobile Number Portability and Tier One Address Resolution (**ENUM**) feature of the Oracle Communications EAGLE enhances the ability of EAGLE to access the Number Portability database (RxDB) using ENUM protocol. Using the ENUM interface supported on UDP, EAGLE is able to process a destination number lookup in an IP-based addressing scheme in the Number Portability database and provide a routing solution to the originating carrier.

2.154.1 Hardware

The ENUM feature is supported on the E5-SM8G-B card running the ENUMHC GPL. A maximum of 16 E5-SM8G-B cards per EAGLE can be configured as ENUM cards.

2.155 Embedded OAP (Release 24.0)

Description

The **OAP** is a stand alone processor that acts as an interface between the **EAGLE** and operation support system (**OSS**) devices using standard interfaces and converting the communications to the **EAGLE** proprietary serial interface. The **OAP** can be used as an interface between the **EAGLE** and the **SEAC** (Signaling Engineering and Administration Center), for the **SEAS** feature, and as an interface between the **EAGLE** and the **SMS** (Service Management System), for the **LNP** feature. The **OAP** is installed in the **OAP** frame of the **EAGLE**.

When used as an interface between the **SEAC** and the **EAGLE**, the **OAP** processes **SEAS** commands into **EAGLE** commands and **EAGLE** commands into **SEAS** commands.

When used as an interface between the **SMS** and the **EAGLE**, the **OAP** receives **LNP** data and commands from the **SMS** and converts the **SMS** commands into **EAGLE** commands and the **LNP** data is loaded onto the **EAGLE**.

The Embedded **OAP** (**EOAP**) replaces the existing Texas Micro **OAP** with a modular unit with field replaceable components which meet or exceed all of the **OAP**'s current capabilities. In addition, the **EOAP** provides for the future enhancement of the **OAP**'s responsibilities.

There are two **EOAPs** in the system, **EOAP-A** and **EOAP-B**. The **EOAP** is in the **EOAP** shelf which is located in the **OAP** frame. Each **EOAP** in the dual configuration consists of a processor card, an interface card, a power supply card, and a center bay containing a removable hard drive and a **CD-ROM** drive for each **EOAP**. Figure *Embedded OAP* illustrates the layout of the system. For a functional block diagram, see figure *Functional Block Diagram of the EOAP*.

Figure 2-32 Embedded OAP

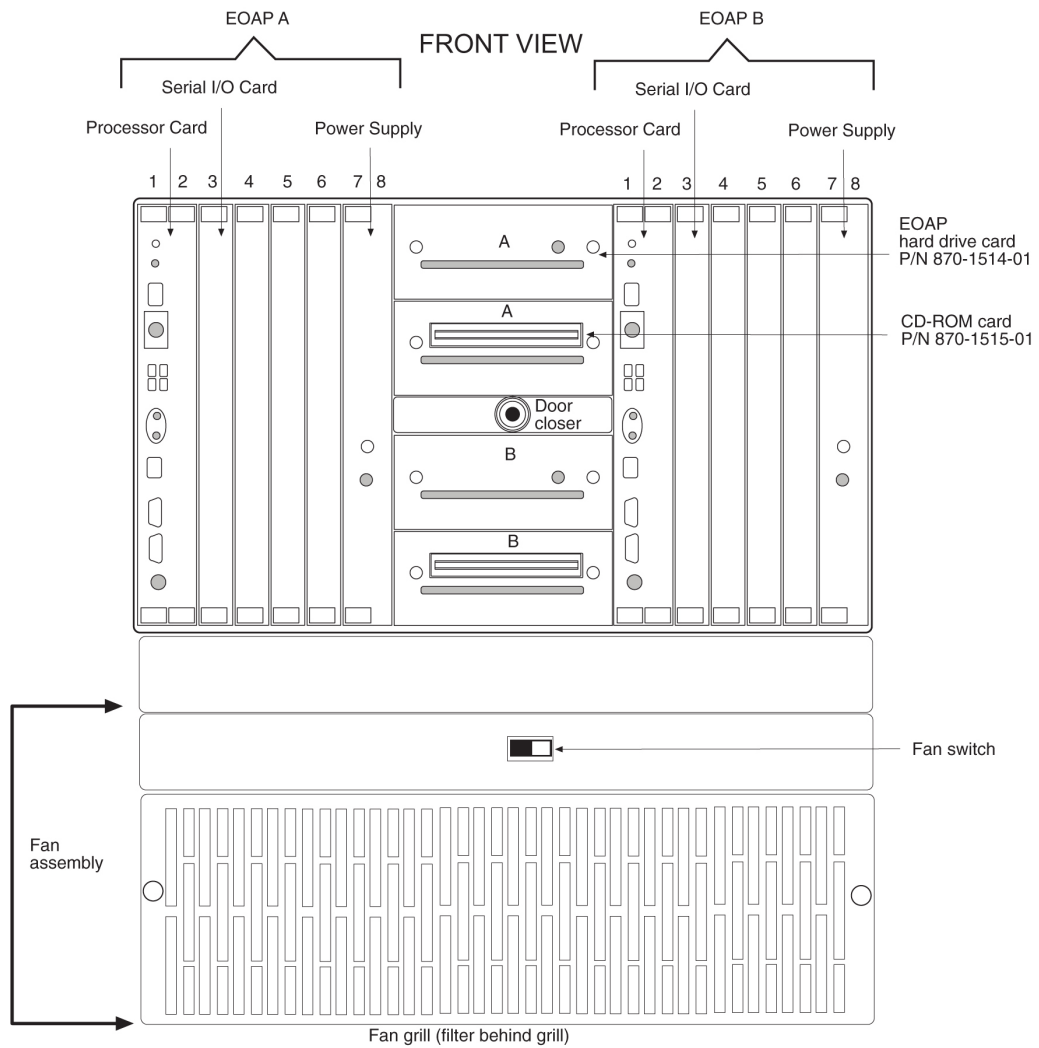

The following figure shows a functional block diagram of the EOAP.

Figure 2-33 Functional Block Diagram of the EOAP

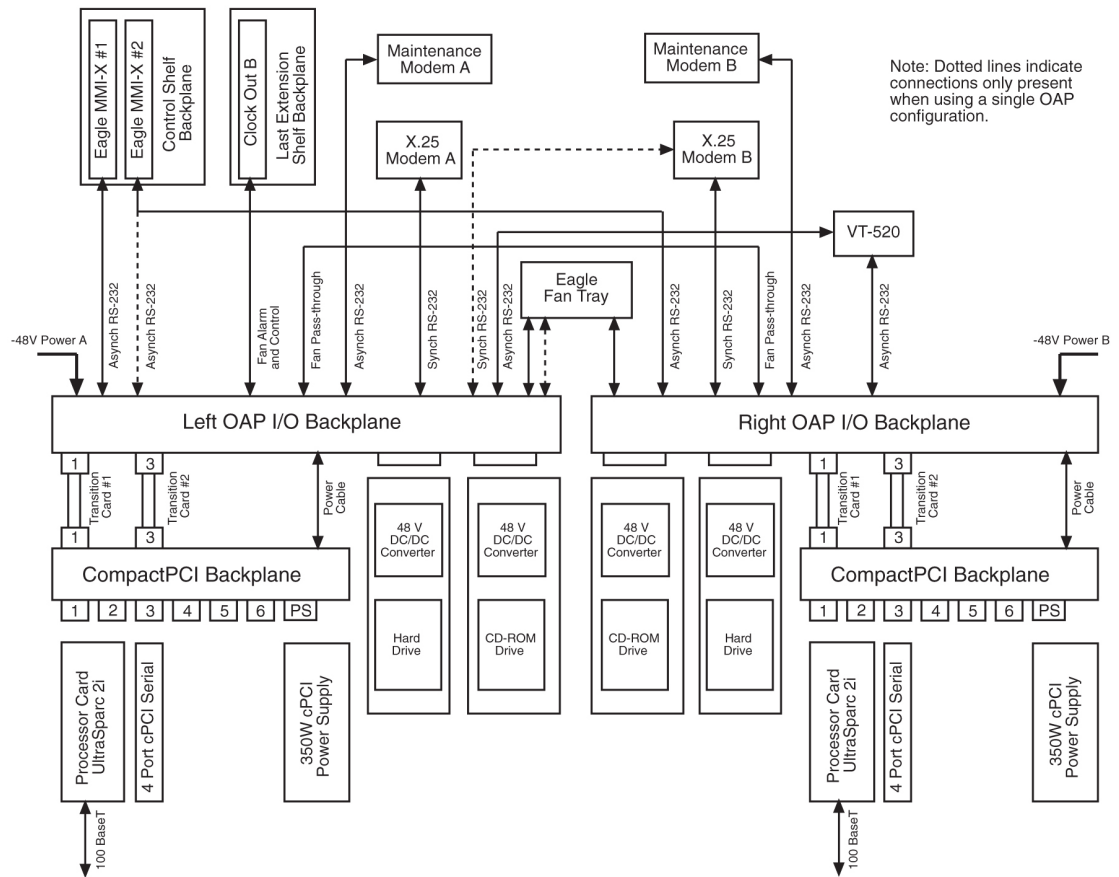

The following table shows the hardware components of the **EOAP**.

Table 2-33 Hardware Requirements of the EOAP

Component	Part Number
Processor Card with the UltraSparc 2i processor and 64 MB of RAM (expandable to 1 GB)	800-0271-01
4-Port Serial I/O Card	800-0272-01
350W 48V DC/DC Power Supply	800-0274-01
	800-0267-01
CompactPCI Backplane	850-0489-01
Tekelec APC SCSI Hard Drive - 4 GB minimum	870-1514-01
Tekelec APC 32X SCSI CD-ROM Drive	870-1515-01
Tekelec Right OAP I/O Backplane	850-0487-01
Tekelec Left OAP I/O Backplane	850-0488-01
Tekelec Transition Card - Processor Card to the OAP I/O Backplane	850-0496-01
Tekelec Transition Card - Serial I/O Card to OAP I/O Backplane	850-1514-01

EOAP Processor Card - P/N 800-0271-01

Slots 1 and 2 of the **EOAP** contains the processor card using the UltraSparc 2i processor. This card provides two serial ports, A and B, for connecting the **EOAP** to the **EAGLE**. Serial port A is accessible from the **EOAP** backplane and from an **RS232C** mini-DIN8 serial interface on the front panel. Serial port B is accessible from the **EOAP** backplane. Both serial ports provide **RS232** asynchronous modem support.

Caution:

The front panel interface on serial port A is provided for monitor output. However, no provision has been made to safeguard the processor card against data entry from the front panel interface. Data input through the front panel serial port is allowable so long as serial port A is not accessed from the rear panel while this occurs. Unpredictable events will occur on the processor card if data is simultaneously input on serial port A through the front panel and back panel connectors.

An **RJ-45** Ethernet port on the front of the card provides a negotiated 10/100BaseT network access for **LNP** support using the **LSMS**.

The processor card also contains a seven-segment **LED**, a system status **LED**, a user configurable alarm **LED**, and abort and reset capabilities through both manual and software intervention.

The seven segment **LED** displays the numeric values 0 through 9 and the alphabetic values A through F and H. If the seven-segment **LED** is displaying a number zero, the processor has been halted. If the seven-segment **LED** is displaying a number one, the processor is operating normally. If the seven-segment **LED** is blank, the processor is being reinitialized. The other values for the seven-segment **LED** have not been defined in Release 24.0.

The processor card is a field replaceable unit. If the processor card is replaced, new license keys must be installed on the hard drive through the **EAGLE** initiated **OAP** user interface. This is due to the change in the Host **ID** that will occur with the new processor card.

The processor card is equipped with 64 **MB** of **RAM**, and is expandable to 1 **GB** of **RAM**.

4-Port Serial I/O Card - P/N 800-0272-01

Slot 3 of the **EOAP** contains the 4-port serial I/O card, which supplies four **RS-232C** serial ports. These ports are accessible from the backplane. Two of these ports are used for interfacing the **EOAP** with **SEAS**. The other two ports are used to connect the **EOAP** to a **VT-520** console or to an **RS232C** asynchronous modem. The 4-port serial I/O card is a field replaceable unit.

350W Power Supply - P/Ns 800-0274-01 and 800-0267-01

The power supply for the **EOAP** is a field replaceable unit that occupies slots 7 and 8 of the **EOAP**. One of two power supplies can be used on the **EOAP**. P/N 800-0274-01 is the preferred power supply to use with the **EOAP**. This power supply is a **DC-DC**

switcher-style power supply. Power supply P/N 800-0276-01 is an alternate power supply that can be used on the **EOAP** and is based on Astec **DC-DC** converters.

Two **LEDs** are located on the front of the power supply. The **POWER GOOD LED** (a green **LED**) should be on when input voltage falls within the allowable range of -48 to -72 **VDC**. The **FAULT LED** (a red **LED**) indicates that an internal fault has occurred. These faults include over-voltage, input **DC** fail warning, loss of output power, and temperature exceeding set limits.

The following table shows the specifications of both power supplies.

Table 2-34 Power Supply Specifications

Specification	Power Supply P/N 800-0274-01	Power Supply P/N 800-0267-01
Input Range	36VDC - 72VDC	40VDC - 72VDC
Efficiency	75% Typical, derated 2.5% per degree above 40 degrees C	75% typical, derated 10W per degree over 50 degrees C
Ripple/Noise	greater of 1% peak-peak or 50mV	50mV max. for all outputs, peak-peak, dc to 20MHz with coaxial probe and 0.1uF/22uF capacitors at the connector
Connector	Positronics P/N PCI38M 400A1	Positronics P/N PCI38M 400A1
Outputs	+3.3 V - 40A maximum * +5.0 V - 50A maximum * +12.0V - 12A maximum -12.0 V - 2A maximum * - Combined 3.3V and 5.0V current not to exceed 50A	+3.3 V - 25A maximum +5.0 V - 50A maximum +12.0V - 9A maximum -12.0 V - 2A maximum
Inrush Current	60 A maximum @ 72V 40 A maximum @ 48V 20 A maximum @ 36V	15 A maximum
Internal Fuse	15A replaceable fuse	15 A replaceable fuse

Hard Drive and CD-ROM Drive

The center section of the dual **EOAP** system contains four individual drive bays. The first and third drive bays contain a **SCSI** hard drive (P/N 870-1514-01) with a minimum capacity of 4 **GB**, and is a field replaceable unit. The first drive bay is hardwired to **EOAP-A** and the third drive bay is hardwired to **EOAP-B**. If the hard drive is replaced, all site specific information must be reloaded on the **EOAP** from the **EAGLE**.

The second and fourth drive bays contain a 32X **SCSI CD-ROM** drive (P/N 870-1515-01). The second drive bay is hardwired to **EOAP-A** and the fourth drive bay is hardwired to **EOAP-B**. The **CD-ROM** drive is a field replaceable unit.

EOAP Connectors

The cards in slots 1 through 8 for each **EOAP** are connected to the **CPCI** backplane (P/N 850-0489-01) as shown in figure *Functional Block Diagram of the EOAP*. The interface from the **EOAP** to the **EAGLE** is provided through another set of backplanes, the left and right backplanes (P/Ns 850-0488-01 for the left backplane and 850-0487-01 for the right backplane). The layout of the left and right backplanes is shown in figure *EOAP Backplane and Connectors*. The hard disk and **CD-ROM** drive for each **EOAP** connect directly to the left and right backplanes. The **CPCI** backplane connects to the right and left backplanes with the

APC Transition Cards, one for the processor card - P/N 850-0496-01, and one for the serial I/O card - P/N 850-1514-01. The transition cards only provides an electrical connection between the **CPCI** backplanes and the left and right backplanes for the **EOAP** assembly. The transition cards do not perform any processing of the signals from either backplane.

Figure 2-34 EOAP Backplane and Connectors

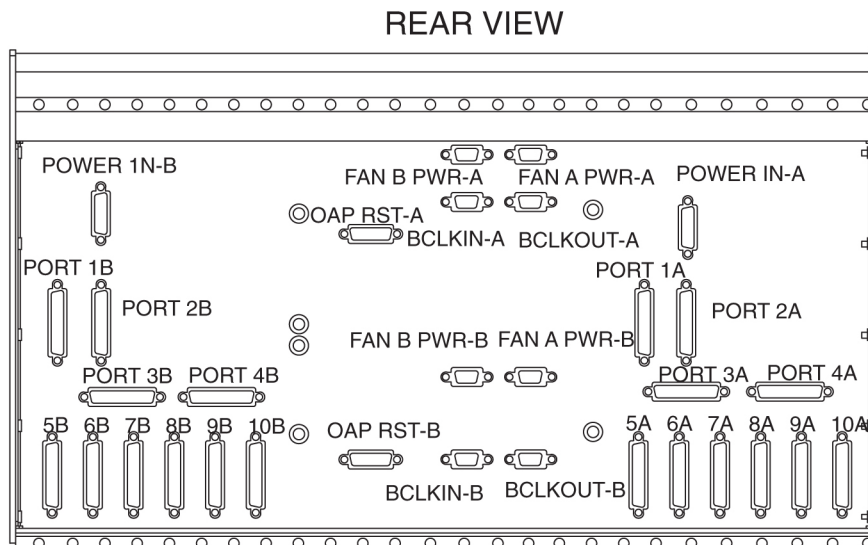

External Interface Descriptions

The next two tables show the connectors used on the backplanes of the **EOAP** and on the front of the processor card.

Table 2-35 External Interfaces - OAP A

Connector (Silkscreen Label)	Signal	DESCRIPTION (Software name in parenthesis)	TYPE	Usage/ Destination
POWER IN-A	System Power	-48VDC, CHASSIS GND , -48VDCRTN	N/A	From Fuse Panel
FAN A-PWR-A	Fan A Power	FAN POWER, ALARM, CONTROL	N/A	To Fan Assembly
FAN B-PWR-A	Fan B Power	Fan Power, Alarm , Control	N/A	To Fan Assembly
OAP RST-A	Oap Reset	OAP Hard Reset Lines	N/A	Currently Unused
BCLKIN-A	B Clock Input	Provides Fan Alarm/Control From EAGLE to Fan A	N/A	From Last Extension Shelf Backplane
BCLKOUT-A	B Clock Output	Provides Fan Alarm/Control to Fan B	N/A	To System B BCLKIN

Table 2-35 (Cont.) External Interfaces - OAP A

Connector (Silkscreen Label)	Signal	DESCRIPTION (Software name in parenthesis)	TYPE	Usage/ Destination
1A	RS-232	Processor Card - Slots 1 and 2 (/dev/term/a)	Asynchronous	EAGLE Terminal Port
2A	RS-232	Processor Card - Slots 1 and 2 (/dev/term/b)	Asynchronous	EAGLE Terminal Port
3A	RS-232	Serial I/O Card - Slot 3 (/dev/term/0)	Asynchronous	VT-520 Terminal
4A	RS-232	Serial I/O Card - Slot 3 (/dev/term/1)	Asynchronous	Maintenance Modem
5A	RS-232	Serial I/O Card - Slot 3 (hih0)	Synchronous	X.25 Port
6A	RS-232	Serial I/O Card - Slot 3 (hih1)	Synchronous	X.25 Port
7A	RS-232	Reserved for future expansion through Slot 4	Asynchronous or Synchronous	Currently Unused
8A	RS-232	Reserved for future expansion through Slot 4	Asynchronous or Synchronous	Currently Unused
9A	RS-232	Reserved for future expansion through Slot 4	Asynchronous or Synchronous	Currently Unused
10A	RS-232	Reserved for future expansion through Slot 4	Asynchronous or Synchronous	Currently Unused
Front Ethernet Port (RJ-45)	100BsT	LAN Connection	10/100BaseT	Connection to LSMS via LAN
Front Serial A/B Port	RS-232	Not used, CANNOT be used while rear serial ports are in use.	Asynchronous	Not to be used in standard configuration
RESET Switch	POR	Mechanical reset key, when enabled and toggled, generates a push-button Power On Reset (POR) to the UltraSPARC-21. Same affect as a Power On Reset from the power supply, except set status bit B_POR in the Reset_Control Register.	Mechanical Switch	To be used when a hard reset is required. System must be halted prior to execution to ensure disk integrity.
ABORT Switch	XIR	Mechanical abort key, when enabled and toggled, generates XIR (externally initiated reset) without resetting the whole system. Sets B_XIR in Reset_Control register.	Mechanical Switch	To be used when abort is required. System must be halted prior to execution to ensure disk integrity.
Front SCSI Port	SCSI-2	Auto-terminating narrow SCSI-2	SCSI-2	Reserved for use by manufacturing

Table 2-35 (Cont.) External Interfaces - OAP A

Connector (Silkscreen Label)	Signal	DESCRIPTION (Software name in parenthesis)	TYPE	Usage/ Destination
Front Keyboard Port	Sun Keyboard and Mouse	8-pin mini-DIN	Asynchronous	Supports Sun Keyboard and Mouse (Unused)

Table 2-36 External Interfaces - OAP B

Connector (Silkscreen Label)	Signal	DESCRIPTION (Software name in parenthesis)	TYPE	Usage/ Destination
POWER IN-B	System Power	-48VDC, CHASSIS GND , -48VDCRTN	N/A	From Fuse Panel
FAN A-PWR-B	Fan A Power	FAN POWER, ALARM, CONTROL	N/A	To Fan Assembly
FAN B-PWR-B	Fan B Power	Fan Power, Alarm , Control	N/A	To Fan Assembly
OAP RST-B	Oap Reset	OAP Hard Reset Lines	N/A	Currently Unused
BCLKIN-B	B Clock Input	Provides Fan Alarm/Control From EAGLE to Fan A	N/A	From Last Extension Shelf Backplane
BCLKOUT-B	B Clock Output	Provided for future expansion of additional Fan Assemblies	N/A	Currently Unused
1B	RS-232	Force Processor - Slot 1 (/dev/term/a)	Asynchronous	EAGLE Terminal Port
2B	RS-232	Force Processor - Slot 1 (/dev/term/b)	Asynchronous	EAGLE Terminal Port
3B	RS-232	Aurora Serial I/O - Slot 3 (/dev/term/0)	Asynchronous	VT-520 Terminal
4B	RS-232	Aurora Serial I/O - Slot 3 (/dev/term/1)	Asynchronous	Maintenance Modem
5B	RS-232	Aurora Serial I/O - Slot 3 (hih0)	Synchronous	X.25 Port
6B	RS-232	Aurora Serial I/O - Slot 3 (hih1)	Synchronous	X.25 Port
7B	RS-232	Reserved for future expansion through Slot 4	Asynchronous or Synchronous	Currently Unused
8B	RS-232	Reserved for future expansion through Slot 4	Asynchronous or Synchronous	Currently Unused
9B	RS-232	Reserved for future expansion through Slot 4	Asynchronous or Synchronous	Currently Unused

Table 2-36 (Cont.) External Interfaces - OAP B

Connector (Silkscreen Label)	Signal	DESCRIPTION (Software name in parenthesis)	TYPE	Usage/ Destination
10B	RS-232	Reserved for future expansion through Slot 4	Asynchronous or Synchronous	Currently Unused
Front Ethernet Port (RJ-45)	100BsT	LAN Connection	10/100BaseT	Connection to LSMS via LAN
Front Serial A/B Port	RS-232	Not used, CANNOT be used while rear serial ports are in use.	Asynchronous	Not to be used in standard configuration
RESET Switch	POR	Mechanical reset key, when enabled and toggled, generates a push-button Power On Reset (POR) to the UltraSPARC-2I. Same affect as a Power On Reset from the power supply, except set status bit B_POR in the Reset_Control Register.	Mechanical switch.	To be used when a hard reset is required. System must be halted prior to execution to ensure disk integrity.
ABORT Switch	XIR	Mechanical abort key, when enabled and toggled, generates XIR (externally initiated reset) without resetting the whole system. Sets B_XIR in Reset_Control register.	Mechanical Switch	To be used when abort is required. System must be halted prior to execution to ensure disk integrity.
Front SCSI Port	SCSI-2	Auto-terminating narrow SCSI-2	SCSI-2	Reserved for use by manufacturing
Front Keyboard Port	Sun Keyboard and Mouse	8-pin mini-DIN	Asynchronous	Supports Sun Keyboard and Mouse(Unused)

Asynchronous Maintenance Modem

Although not provided with the **EOAP**, a Hayes compatible modem can be connected to the **EOAP** to provide connectivity for remote monitoring and maintenance. This allows access to the **EOAP** as required by Tekelec Technical Services. The modem is connected to the **EOAP** through the 4-Port Serial I/O **Card** through connectors 4A or 4B on the **EOAP** backplanes. The modem must be configured as shown in table *Modem Configuration*. See tables *External Interfaces - OAP A*, *External Interfaces - OAP B*, and figure *EOAP Backplane and Connectors* for the designation and location on the backplanes of each connector.

Table 2-37 Modem Configuration

Modem Parameter	Value
Baud Rate	9600 bits per second
Data Bits	7
Parity	Even

Table 2-37 (Cont.) Modem Configuration

Modem Parameter	Value
Stop Bits	1

EOAP User Console

The user console for the **EOAP** is provided by a Digital Equipment Corporation **VT520** terminal. The **VT520** is connected to the **EOAP** using an **RS232C** terminal cable attached to connectors 3A or 3B on the **EOAP** backplanes. See tables *External Interfaces - OAP A*, *External Interfaces - OAP B*, and figure *EOAP Backplane and Connectors* for the designation and location on the backplanes of connectors 3A or 3B. This terminal allows for monitoring and direct interfacing capabilities to the **EOAP** and must be set up for **VT100** emulation.

Fans

To help keep the **EOAP** cool, the **EAGLE** fan assembly is mounted underneath the **EOAP**. The fan assembly consists of eight fans, two **LEDs**, and a three-way switch. The fan assembly is powered from the A and B power sources on the **EOAP** backplanes (connectors **FAN A-PWR-A**, **FAN A-PWR-B**, **FAN B-PWR-A**, and **FAN B-PWR-B2**, see tables *External Interfaces - OAP A*, *External Interfaces - OAP B*, and figure *EOAP Backplane and Connectors*).

The three-way switch allows the user to specify how the fans are controlled. The normal position of the switch allows the system software to control when the fans are turned on and off. The **ON** and **OFF** positions of the switch turns the fans on and off and overrides any control by the system software.

One of the **LEDs** shows whether the fans are on (**LED** is green) or off (**LED** is off). The second **LED** (see table *Fan Alarm Status*) shows the alarm status of the fans.

Table 2-38 Fan Alarm Status

LED	Alarm Status
Green	No Fan Alarm
Red	Fan Alarm
Off	No Power

UAMs

If there is a failure of any of the fans, or if the three-way switch is in the **OFF** position, the alarm status **LED** is red, and a minor alarm (unsolicited alarm message 302) is generated at the **EAGLE**.

```
RLGHNCXA03W 99-01-07 00:57:31 EST Rel 24.0.0
* 0055.0302 * SYSTEM Cooling Fan Failure
```

When the fan failure is cleared, or when the three-way switch is placed in either the **ON** or normal position, the fan alarm is cleared, the alarm status **LED** is green, and unsolicited alarm message 303 is generated at the **EAGLE**.

```
RLGHNCXA03W 99-01-07 00:57:31 EST Rel 24.0.0
0056.0303 SYSTEM Cooling Fans Normal
```

The fan alarm and control input and output are obtained from the Clock Out B connector on the last **EAGLE** extension shelf and connected to the **BCLKIN-A**, **BCLKIN-B**, **BCLKOUT-A**, and **BCLKOUT-B** connectors on the **EOAP** backplanes. See tables *External Interfaces - OAP A*, *External Interfaces - OAP B*, and figure *EOAP Backplane and Connectors* for the designation and location on the backplanes of each connector.

Third Party Software

The following table shows the third party software and the versions of the software required by the **EOAP**.

Table 2-39 Third Party Software for the EOAP

Product	Vendor	Embedded OAP Version
DSET APLI	DSET	4.1.3f compiled for Solaris version 2.5.1
DSET DSGRuntime	DSET	4.1.3f compiled for Solaris version 2.5.1
Solstice OSI	Sun	8.1.1
Solaris	Sun	2.5.1
SunLink HSI/S	Sun	2.0
Solstice X.25	Sun	9.1
NetPilot UAL Software	Bellcore	8.2
Performance Technologies Driver	Performance Technologies	810P027930

EOAP to EAGLE Interface

The **EOAP** is connected to the **EAGLE** through the **EOAP** backplane. The two serial ports on the processor card are used for this connection. The cables are connected to any two of the terminal ports (**MMI 0-MMI 15**) on the **EAGLE** control shelf backplane.

The **EOAP** connected to the lower numbered terminal port is considered by the **EAGLE** to be **OAP A**, and the **EOAP** connected to the higher numbered terminal port is considered by the **EAGLE** to be **OAP B**.

The terminal port being used by the **EOAP** must be configured in the **EAGLE** with the `type=oap` parameter of the `chg-trm` command. When the `type=oap` parameter is specified with the `chg-trm` command, none of the communication attribute parameters, `baud` (the baud rate of the terminal port), `prty` (the parity of the terminal port), `sb` (the number of stop bits for the terminal port's **RS-232** connection), and `fc` (the type of flow control for the terminal port's **RS-232** connection) can be specified. These parameters are defaulted to the values shown in the following table.

Table 2-40 EAGLE Terminal Port Configuration for the EOAP

Terminal Port Parameter	Value
Baud Rate (<code>baud</code>)	19200 bits per second
Parity (<code>prty</code>)	even
Stop Bits (<code>sb</code>)	1
Flow Control (<code>fc</code>)	hw - hardware flow control

To allow the user to reset the **EOAP** from the **EAGLE** terminal, an alarm/reset cable connects to the **EOAP** at the **OAP RST-A** and **OAP RST-B** connectors and on the **EAGLE** at the **OAPALM** connector on the control shelf backplane. The **EAGLE** `init-oap` command is used to initiate the reset of the **EOAP**. The `init-oap` command uses the parameters `oap` and `force`.

- `oap` – Specifies which **OAP** is being initialized, as considered by the **EAGLE**.
 - `a` – **OAP A**
 - `b` – **OAP B**
 - `both` – Both **OAPs**
- `force` – Forces the reset of the specified **OAP** if that **OAP** is operational (its state is either **IS-NR**, in-service normal, or **IS-ANR**, in-service abnormal) and it is the only operational **OAP**. The values for this parameter are either `yes` or `no`. If the specified **OAP** is not operational, the `force=yes` parameter is not required. The default value for the `force` parameter is `no`.

If the specified **OAP** is the only operational **OAP** and the `force=yes` parameter is not specified for the `init-oap` command, the `init-oap` command is rejected with this message.

```
E2813 Cmd Rej: FORCE=YES must be specified to initialize the last OAP
```

The `init-oap` command requires that the **SEAS** feature is on, or the `init-oap` command is rejected with this message.

```
E2812 Cmd Rej: SEAS feature or LNP feature is not configured
```

EOAP to SEAS Interface

The **EOAP** is connected to the **SEAC** using these connectors on the **EOAP** backplanes: 5A, 5B, 6A, and 6B. From one of these ports, an **RS232C** cable is connected to a 9600 bps synchronous modem, which in turn is connected to the **SEAS** system. If only a single **EOAP** is being used, both ports on that **EOAP** are connected to two separate modems. If both **EOAPs** are being used, only one port on each **EOAP** is connected to a modem that is connected to the **SEAS** system. See tables *External Interfaces - OAP A*, *External Interfaces - OAP B*, and figure *EOAP Backplane and Connectors* for the designation and location of each connector on the backplanes.

EOAP to LSMS Interface

The **EOAP** is connected to the **LSMS** through the Ethernet port (an **RJ-45** connection) located on the front of the Processor **Card** using a 10/100BaseT cable.

The **EOAP** handles eight messages from the **LSMS** at a time (process and respond to the **LSMS**), although multiple messages may be sent to the **EOAP**. No more than eight messages should be sent from the **LSMS** to the **EOAP** without a response being returned by the **EOAP**. If more than one message is sent to the **EOAP** without the **LSMS** waiting for a response, the **LSMS** must manage retries and the sequencing of messages.

The **EOAP** must be configured locally with the **LSMS OSI-Address** information necessary for association establishment. The **EOAP** will initiate association connections with the **LSMS**.

2.156 End Office Support (IP⁷ Release 5.0)

Description

Customers see the **IP⁷ Secure Gateway** product as a means by which they can take advantage of next generation network technology by migrating existing signaling end points from the **PSTN** to the **IP** network. The fact that the **SG** is a signaling transfer point and has its own point code, however, presents a significant network management issue for them. Some customers do not want to obtain a new point code and reconfigure their network in order to introduce the **SG** and an **IP** end office node. This feature provides such customers the means to perform the migration without using a new point code or reconfiguring their network.

Refer to the *Database Administration Manual - Features* for current information on this feature.

Upgrade Considerations

The upgrade of fielded **SG** software will take into account the changes introduced by End Office Support, and no degradation of system capability will occur from such an upgrade. This feature adds the new Remote Application Table.

Limitations

- The **APC** assigned to an **IPGW** linkset should not be used as an **IPC** for an **EO** Node. The **IPGWx** application is to be used as a redundant pair of cards. Proper use would involve having equal cost routes to each linkset of a pair of **IPGWx** cards. This scheme prevents the use of the **IPGWAPC** since only one route should exist to that point code. In addition, the **IPGWx** application currently expects to receive only **SNMs** for the **IPGWAPC**. All messages received for the **IPGWAPC** are discarded, though **SNMs** may generate **MTP** primitives. This feature will not prevent the **IPGW APC** being provisioned as an **IPC**, but **IPGWx** will discard the traffic destined to the **IPC** for this configuration.
- A third point code, the **IPC**, must be assigned to the **EO** Node, in order to allow two equal cost routes to be provisioned.
- The End Office Support feature allows one or more **IP** network elements to share the **SG's** true and secondary point codes. **IP** nodes having their own point code are also supported, but not as end office nodes. This feature eliminates one and only one point code for a given network type.
- This feature provides no method for a mated pair of **SGs** to share an End Office Node. An End Office Node shares the true or secondary point code of the **SG**. Each **SG** of a

mated pair continues to require a unique true point code. There are no benefits of redundancy if mated **SGs** share an **IPNE** operating as two **EO** Nodes.

- This feature prevents an **IP** end office node from receiving through-switched messages having **SI=0**, **SI=1**, and **SI=2**, with the exception of **UPUs**. If such messages are desired, then the **IP** network element cannot be configured as an end office node.
- An end office node cannot share a **SCCP** subsystem other than **SCMG** with the **SG**. An end office node's **SCCP** subsystem takes priority over the **SG's** local **SCCP** subsystems.
- An end office node must not generate non-**UPU**, non-**TFC**, and non-**RCT** network management messages having **OPC=TSPC** or **CPC=TSPC**. The **IPGWx** application will discard such messages that it receives.
- There are no new measurements specific to the End Office feature. Existing per-socket measurements can be used to see the number of **MSUs** going to and received from each socket.
- Messages arriving at the **SG** from the network and having **DPC=IPC** shall be routed, just as if the message had arrived having **DPC=TSPC** and an assigned remote application. Such a message will bypass the new discrimination algorithm and be immediately forwarded to the **EO** Node.
- This feature shall not prevent a user from provisioning a routing key having **DPC=IPC**. The **IPGWx** will not generate network management when such a routing key changes states. Messages arriving at the **IPGWx** cards with **DPC=IPC** are changed to have **DPC=TSPC** prior to routing key lookup, and so a routing key having **DPC=IPC** will never be a match for a message. If no matching routing key having **DPC=TSPC** is available, then **MSUs** with **DPC=IPC** arriving at the **IPGWx** for transmission will be silently discarded with private pegs.

2.157 Enhance GSM MAP Screening to add TC_Continue and End (Release 35.1)

Description

The Enhance **GSM MAP** Screening to add **TC_Continue** and End feature enhances the **GSM MAP** Screening, Enhanced **GSM MAP** Screening, and **MTP**-based **GSM** Screening features by enabling **MAP** screening to be performed on non-segmented **TC_Continue** and **TC_End** messages.

In order for **MAP** screening to occur, the messages must meet the following requirements:

- **TCAP-CONT** messages must have an Invoke component type.
- **TCAP-END** messages must have a Return-Result (Test) type.

Screening is not performed on messages that do not meet these requirements.

Hardware Requirements

The Enhance **GSM MAP** Screening to add **TC_Continue** and End feature has no hardware requirements.

Limitations

The **GSM** Map Screening feature must be on before the Enhance **GSM MAP** Screening to add **TC_Continue** and End can be enabled.

2.158 Enhance RTRV-LOG (Release 31.3)

This enhancement will allow the customer to customize **RTRV-LOG** output. The following list contains examples of customized reports of the logs:

- Filtered for a particular Output Group
- Separated between **UIMs** and Alarms and further separated by Output Group
- Filtered by a given alarm number or range of numbers.

In addition, this command is modified to become a cancelable command, allowing a user or sysadmin to stop the processing of the command at any time during its execution.

The **RTRV-LOG** enhancement feature also included a new command (rtv-trbltx) that allows the craftsperson to display information from the trbltx table, which contains all of the **UIMs** and Alarms for each **EAGLE** release. The information displayed for each entry of the trbltx table will be the **MRN**, alarm severity (for Alarms), Output Group and text. Optional parameters for rtv-trbltx allow the craftsperson to display a subset of the information available to them. The optional parameters for rtv-trbltx allow an Output Group or **TYPE** to be specified or a range of **MRN** numbers to be specified. Additionally, all Output Groups may be displayed with a list of **MRNs** that match each Output Group.

2.159 Enhanced Bulk Download (Release 25.0)

The **EAGLE** Enhanced Bulk Download (**EBD&A**) feature adds “infrastructure” to the **EAGLE** that supports the implementation of higher functionality at the **LSMS**.

For current details of this feature, refer to the **LNPDatabase Synchronization Manual**.

Hardware Requirements

As previously stated, this feature requires the following additional **EAGLE** hardware, which is devoted to the **EBD&A** function:

- One (1) **DCM** card and **FANS**.
- One (1) **BLM** card. This **BLM** card must be equipped with enough applique memory cards to be able to load the entire **LNP DB**. Specifically, the applique requirements for the **EBD&A BLM** card are exactly the same as the memory requirements for a **TSM** card running the **SCCP** application.

Additional memory is required on the **SCCP** cards to support the addition of 12 million ported numbers. Memory may be added in 256 **MByte** increments to the **TSMs**, up to a maximum of 1024 Mbytes of memory.

The following **TSM** configurations are supported:

- **TSM256**: **TSM** with 256 **MB** populated memory. Maximum number of ported numbers supported: 2,000,000.
- **TSM512**: **TSM** with 512MB populated memory. Maximum number of ported numbers supported: 4,000,000.

- **TMS768:** TSM with 768MB populated memory. Maximum number of ported numbers supported: 6,000,000.
- **TSM1024:** TSM with 1024MB populated memory. Maximum number of ported numbers supported: 8,000,000 without optional software feature, 12,000,000 with optional software feature. In addition, the parameter `lnp12mil=on` must be set.

Refer to the **NSD Hardware Manual** for current hardware information.

Serviceability

LSMS ↔ DCM Ethernet Security

Security of the **LSMS ↔ DCM** ethernet connection is the customer's responsibility. Neither the **EAGLE** nor the **LSMS** will provide any type of security to thwart unauthorized attempts to access the **EAGLE** and/or **LSMS** by "hijacking" the connection.

If the customer is concerned about security (e.g. a hacker who gains access to the **EAGLE** by masquerading as an **LSMS**, and downloading a faulty database to **EAGLE** via the bulk download facility), he should take steps to ensure that security is not compromised. One such method would be to provide the **LSMS ↔ DCM** connection totally within the customer's own internal network, and install a firewall between the customer's internal network and the "outside world," as illustrated in the following figure.

Figure 2-35 LSMS ↔ DCM Connection with Firewall

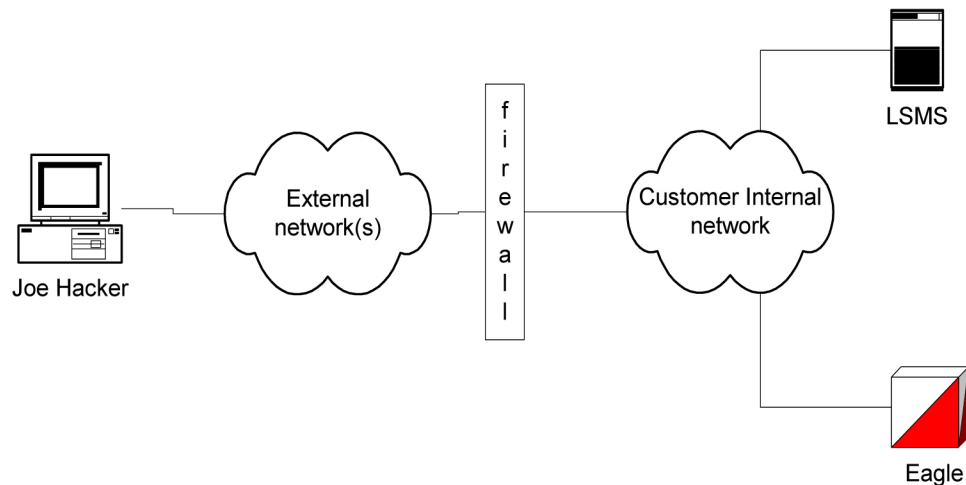

Administration of the EBD&A Feature

Provisioning of Necessary BLM and DCM Components

For the **EBD&A** feature to operate, a dedicated **BLM** and **DCM** must be present and running the new **GPLs** developed for this feature.

- Associating the new **EBD&A GPLs** with the **DCM** and **BLM** card types is accomplished by the existing `ent-card:appl=` command to accept new **GPL** types (**EBDADCM**, **EBDABLM**).

- Other commands that could affect the loading or monitoring of these **BLM** and **DCM** components of **EBD&A** have been modified to accommodate the new **GPL** types as necessary.

Provisioning of EBD&A DCM Ethernet Details

Provisioning of this information is performed by new commands. The following scenario shows the minimum number of steps required to configure the **DCM** card, so that it is functional for **EBD&A** purposes:

1. `chg-ip-card:loc=xxxx:`

This command provides little information for the **EBD&A DCM**, but is a pre-requisite for the command to follow. Since the **EBD&A DCM** card will be acting as a sockets server, additional parameters that this command provides (such as domain name server **IP** address) are not needed.

2. `ent-ip-host:host=dcm_name:ipaddr=a.b.c.d`

This command tells the **DCM** card what hostname is associated with the **DCM** card's **IP** address. The value for the `host=` parameter is required in order to associate the **TCP/IP** port (specified in the next step) with the **TCP/IP** address (specified on the previous step), but its value is unimportant to the **EBD&A DCM**: specify any unique value. The `ipaddr=` value must be the same value that was specified on the `chg-ip-lnk` command.

3. `chg-ip-lnk:loc=xxxx:port=x:ipaddr=a.b.c.d:submask=x.x.x.x:...`

This command tells the **DCM** card at `loc=` to assign the **IP** address (`ipaddr=`) to the indicated port (port in this context is the physical port 'A' or 'B' on the **DCM** card: it does not refer to the **TCP/IP** port number). The **DCM** card now knows what its **IP** address is for the indicated physical port. Additional parameters available for this command can be used if necessary to configure the operational parameters of the **DCM**'s ethernet link (e.g. link speed).

Note:

The **EBD&A** feature is designed to use only the 'A' port of the **DCM** card. Be sure to attach the physical ethernet connection (i.e. the wire) only to the 'A' port, and then configure the 'A' port accordingly. The 'B' port is ignored by the **EBD&A DCM GPL**, even if provisioned via the **CHG-IP-LNK** command. The 'B' port can be configured and used to allow source-level debugging of the **DCM** card via the VxWorks "Tornado" debugging tool.

Selection of DCM Card Slot

The **DCM** card currently takes up 2 slots in the **EAGLE** shelf card cage due to the large heat sink on the top of the **DCM** card. Because of this, the **DCM** cannot be provisioned in any arbitrary slot. Certain slots in the card cage are adjacent to the cage sides, and/or are adjacent to metal supports welded into the card cage. These slots cannot be used to house a **DCM** card.

Also, the **DCM** card requires a substantial amount of power. Due to the way the **EAGLE** fuses power pairs of card slots, the **DCM** should always be provisioned into an odd-numbered card slot. For example, fuse 1A provides power to both slots 1101 and 1102. The combined current draw for both of these slots must not exceed 3A, or the fuse may blow.

Inserting a **DCM** into slot 1102 when there is another card in 1101 could cause the total current requirements for both of these slots to exceed 3A.

Additionally, the shelf equipped with the **DCM** card must be equipped with fans in order to keep the card from overheating.

Minimum LSMS ↔ EAGLE Ethernet Facility

The customer is responsible for selecting and providing a connection between the **EAGLE** and **LSMS** locations so that the **LSMS** and **DCM** components may communicate via ethernet.

Unless the speed of the communications line is very poor, the maximum processing speed of the **EBD&A** feature will most likely be limited by the performance of the **BLM** card, which has a maximum rate of » 400 **DB** inserts/second as previously stated; providing communications facilities of very high capacity will not make the **EBD&A** feature perform its work any faster.

However, selection of an extremely slow communications line will result in **EBD&A** performance degradation.

Assuming the following:

- Maximum **BLM DB** insert rate = 400 entries/second.
- Average size of a **DB** record passed from **LSMS** à **DCM** over ethernet = 95 bytes/entry (Note: maximum size would be 120 bytes/entry).
- **LSMS** is able to extract **DB** entries from its database (Versant) and present them across the ethernet connection to the **EAGLE** as fast as the **BLM** can process them.

In order to keep the **BLM** card 100% busy during bulk download, the ethernet connection must have a transmission rate of:

$400 \text{ entries/second} * 95 \text{ bytes/entry} = 38,000 \text{ bytes/second}$

During high-speed audit, it is estimated that the **BLM** can extract and present 3400 **TN/checksum pairs/second**. The **LSMS**, however, has a measured maximum performance of 1,666 extracts from its database/second, therefore the **LSMS** will most likely be the limiting bottleneck during audits:

$1666 \text{ entries/second} * 9 \text{ bytes/entry} = 14,994 \text{ bytes/second}$

Therefore, Tekelec recommends that the **LSMS** ↔ **EAGLE** communications link installed for the **EBD&A** feature have a transmission capacity of » 38,000 bytes/second.

Upgrade Considerations

New EBD&A GPLs

The **EBD&A** feature introduces two new **GPL** types to Release 25.0. However, upgrades from previous releases to Release 25.0 need not include steps to create these new **GPLs** on the system being upgraded, since Release 25.0 introduces functionality to create feature-specific **GPLs** at the time the feature is installed at the customer site.

Modifications to EAGLE LNP Subscription Records on Disk

A new 4-byte field has been added to each **LNP** subscription record in the **EAGLE LNP DB**. This field is created from unused pad area already present in the record. This new field holds the **CRC-32** checksum for the record, enabling the high-speed audit of the subscription record contents by the **LSMS**. There is no need to obsolete existing **LNP DB** tables, or create new ones, in order to accommodate the new checksum.

2.160 Enhanced Database Status Reports (Release 20.0)

The database level (resident on every card in the system) and the “coherency” indicator are displayed with this feature. The coherency indicator identifies corrupt database files, which can be corrected using database management commands.

2.161 Enhanced GPL Management (Release 25.0)

Description

This feature minimizes the effort required to add new **GPLs** (applications) to **EAGLE** by updating a table of **GPL** attributes. The table makes each application available to all existing commands which contain the "appl = <xyz>" parameter. Likewise, all commands that display an application also have the parameter available.

All commands that use an `appl=` parameter, as well as the commands that administer **GPLs**, must check the existence of the **GPL** definition in the table as part of their semantic validation.

All commands that display an **APPL** as part of their output must retrieve the application name from the new table.

All processes that download applications must retrieve the **GPL DOS** filename from the new table.

Upgrade Considerations

In order to provide access to new **GPLs**, the **APPL** Definitions Table must be updated. Most of this table is filled in at compile time, which means that an updated **OAM GPL** must be provided in order to support new **GPLs**. During the upgrade process, new **GPLs** are available once the updated **OAM** is running.

The feature does not change any **DCBs** or maintenance blocks; thus no on-the-fly conversion of data structures is required.

There are no new **DMS** tables defined by the feature, and no existing **DMS** tables are modified; therefore, no database conversion is required.

2.162 Enhanced GSM MAP Screening (Release 31.4, 39.2)

The existing Enhanced GSM MAP Screening (EGMS) feature is updated as follows:

- Messages can cross between ITUI and ITUN domains and spare domains. Messages remain restricted from crossing between ANSI and ITU domains. If the ANSI ITU SCCP Conversion feature is not turned on, then the domain crossing is performed by altering the message transfer part (**MTP**) portion of the message. If the ANSI ITU SCCP Conversion feature is turned on, then the domain crossing is performed using point code conversion on the point codes for the SCCP called party (**CdPA**) and calling party (**CgPA**).

- The translation type (**TT**) of an outgoing message can be modified per EGMS ruleset.
The MAP SCRN table is searched for a provisioned TT value. If a match is found, then this value is used to set the TT value for the CdPA of the outgoing message. If a match is not found, then the OPCODE table is searched. If a match is not found in either table, then the TT value is not modified, and the outgoing message uses the TT value that existed after global title translation (**GTT**) was performed.
- Non-segmented XUdT and XUdTS messages are supported for GT-routed and MTP-routed GSM messages.

2.162.1 Feature Control Requirements

No additional feature control requirements are associated with the updates to the EGMS feature.

2.162.2 Hardware Requirements

No additional hardware requirements are associated with the updates to the EGMS feature.

2.162.3 Limitations

No additional limitations are associated with the updates to the EGMS feature.

2.163 Enhanced GTT (Release 26.0)

Description

EGTT is an enhancement to the existing **GTT** function. **EGTT** provides the following main enhancements to **EAGLE**'s current **GTT**:

- Increased number of selectors:
- Relaxed **GTT** rules:
- Deletion of **GT**:
- Inclusion of **SSN** in the **CDPA**:
- Inclusion of **OPC** in the **CGPA**:

Refer to the *Database Administration Manual - Features* for current details of this feature.

Upgrade Considerations

After the upgrade and the **EGTT** feature is enabled, any **ITU** selectors added with **GTI=4** that match any pre-upgraded entries will be an exception to the numbering plan and/or nature of address indicator of the pre-upgraded entry. The pre-upgrade entry will now match on any set of numbering plan-nature of address combinations, other than the added post-**EGTT**-enabled entries.

2.164 Enhanced Link Diagnostics (Release 22.0)

Enhanced **Link** Diagnostics provides improved information reporting to aid in the investigation of link failures. **SS7** Level 2 status information is buffered before and after a link failure has occurred. This feature provides the capability to loop the internal transmit and receive data on the **ISCC** chip. **Link** failures can occur on the near end node, far end node or the wire connecting the two nodes. This capability either confirms or eliminates a portion of the near end node as the reason for the link failure.

2.165 Enhanced Load Distribution (Release 21.0)

This feature improves the load distribution of traffic on a combined linkset when a signaling link in one of the linksets in the combined linkset fails.

Before Release 21.0, if a signaling link in a combined linkset fails, the traffic is redistributed to the other links in the same linkset. With this feature, the traffic is redistributed over the signaling links in the combined linkset. This feature applies to both **ANSI** and **ITU** signaling links.

Traffic is distributed over the combined linkset using the signaling link selection (**SLS**) values assigned to the signaling links in each linkset. When a signaling link in the combined linkset fails, the system uses the **SLS** values assigned to the signaling links, the number of signaling links in each linkset, and the number of failed signaling links in the combined linkset to determine which of the remaining signaling links in each linkset will carry the failed signaling link traffic.

To evenly distribute the traffic on all the signaling links in a combined linkset, each linkset in the combined linkset must contain the same number of signaling links.

2.166 Enhanced Routing Key Support (IP⁷ Release 2.0)

Release 2.0 offers several enhancements for the routing key table that the **IP⁷** Secure Gateway uses to route **SS7** Message Signaling Units (**MSUs**) over the **IP** network. The routing table is used for **SCCP/TCAP-over-IP**, **ISUP-over-IP**, and non-**SCCP**/non-**ISUP** connectivity, each of which uses the `ss7ipgw` application.

Understanding the Routing Key Table Used in Release 1.0

The routing key table maps **SS7** Routing Keys to **TCP/IP** socket names, as illustrated by the example in table *Example SS7 Routing Key Table*. **MSUs** that match the parameters in a given row are sent over one of the sockets shown for that row (up to 16 socket associations can be defined for a single routing key). Multiple sockets for a given row allow load sharing. In addition, multiple routing keys can be used to send traffic to a single socket.

Table 2-41 Example SS7 Routing Key Table

SS7 Routing Keys						TCP/IP Sockets that carry traffic for that Routing Key
SS7 DPC	SS7 SI	SS7 SSN	SS7 OPC	CIC START	CIC END	Socket Name
DPC-SI-SSN routing key for SSCP/TCAP-over-IP connectivity						

Table 2-41 (Cont.) Example SS7 Routing Key Table

SS7 Routing Keys						TCP/IP Sockets that carry traffic for that Routing Key
SS7 DPC	SS7 SI	SS7 SSN	SS7 OPC	CIC START	CIC END	Socket Name
5-5-5	03	6	-	-	-	KC_HLR1_1201 KC_HLR2_1201 KC_HLR1_1203 KC_HLR2_1203
ISUP-CIC routing key for ISUP-over-IP connectivity						
5-5-6	05	-	4-4-4	1	100	DN_MSC1_1201 DN_MSC2_1201 DN_MSC1_1203 DN_MSC2_1203
DPC-SI routing key for non- SCCP /non- ISUP connectivity						
5-5-7	02					SF_HLR1_1204

IP⁷ Secure Gateway release 1.0 required the user to use the `ent-appl-rtkey` and `dlt-appl-rtkey` commands to configure the routing key table, which could hold a maximum of 250 keys. For more information about using these commands, refer to the *IP⁷ Secure Gateway Database Administration Manual - Features*.

Enhancements to the Routing Key Table in Release 2.0

IP⁷ Secure Gateway release 2.0 provides the following enhancements for routing keys:

- Routing keys can be dynamically configured by the receipt of a **TALI** message from the **IP** network.
- Routing keys that are statically defined (using the `ent-appl-rtkey` command) can be changed by using a new command `chg-appl-rtkey`.
- Up to 1000 routing key entries per **DCM** card are supported. The customer can specify the maximum number of static keys and dynamic keys to be supported, as long as the total is less than or equal to 1000.

Dynamic Routing Key Registration

This enhancement allows a socket to automatically direct traffic towards, or away from, itself by sending a message to the IP⁷ Secure Gateway. This enhancement allows customers to add IP⁷ routing key intelligence to their IP applications rather than requiring user entry of static routing keys.

When transmitting Message Signaling Units (**MSUs**), the IP⁷ Secure Gateway routing code looks for a dynamic routing key before searching for a static routing key. When a socket fails, all dynamic entries associated with it are deleted. A dynamic routing key entry can have the same parameters as a static key entry.

Adjusting Static Routing Key Entries

IP⁷ Secure Gateway release 2.0 allows the use of the new `chg-appl-rtkey` command to make one of following adjustments to a routing key that has already been statically defined:

- Any existing static entry's socket associations can be overwritten by a new socket association. If the `chg-appl-rtkey` command assigns a new socket name to a routing key has multiple socket associations, all socket associations are replaced with the new socket name.
- Any existing **ISUP-CIC** entry (an entry whose **SI** is equal to 05) can be split into two entries by naming a **SPLIT** value. One entry uses the original **CIC START** value and makes the **CIC END** value equal to one less than the **SPLIT** value. The other entry uses the **SPLIT** value as its **CIC START** value and the original **CIC END** value for its **CIC END** value. Each entry retains the **OPC**, **DPC**, **SI**, and socket name associations from the original entry.
- Any existing **ISUP-CIC** entry (an entry whose **SI** is equal to 05) can have its **CIC** range extended and/or decreased as long as the new range does not overlap the range on any other key.

Only one of these changes can be made with each use of the `chg-appl-rtkey` command. If additional changes are needed, enter the command again for each change needed.

Support of Additional Routing Keys

IP⁷ Secure Gateway release 2.0 supports up to 1000 routing key entries (increased from the previous limit of 250) for each **DCM** card. These 1000 key entries may be either dynamic entries (added by receipt of a request from the **IP** network) or static entries (configured using the `ent-appl-rtkey` and `dlt-appl-rtkey` commands) or a combination of both. The user can specify the maximum number of static entries and dynamic entries allowed using the `chg-sg-opts` command.

An additional change is a parameter added to the `rtrv-appl-rtkey` command to allow the user to specify the maximum number of routing key entries to be displayed.

Understanding the Use of Dynamic and Static Routing Entries for **ss7ipgw** Routing

The **IP⁷** Secure Gateway has two **DCM** cards, each of which contains a routing table of up to 1000 entries. The static entries in one table are identical to the static entries in the other table; the dynamic entries may differ depending on messages received from other **IP** nodes. The following table provides a summary of the characteristics of static and dynamic entries.

Table 2-42 Comparison of Static and Dynamic Entries in Routing Key Table

Characteristic	Static Entries	Dynamic Entries
Provisioned by:	<code>ent-appl-rtkey</code> , <code>dlt-appl-rtkey</code> , and <code>chg-appl-rtkey</code> commands, entered through the OAM , saved on disk, and reloaded to each DCM card upon reset	Receipt of message over socket; purged when socket fails or DCM card is reset
Option of <code>chg-sg-opts</code> command used to set maximum number of entries	<code>srkq</code>	<code>drkq</code>
Same on both DCMs ?	Yes	Not necessarily
Used for routing:	Used only if no matching dynamic entry exists	Used first for routing

2.167 Enhanced Software Loading (Release 20.0)

This feature reduces the **EAGLE**'s reload time during system initialization or restart to less than 5 minutes. To meet this requirement, the system is reloaded from the fixed disk drives on both the active and standby **TDMs** (terminal disk modules). Some subsystems are loaded from one fixed disk drive and other subsystems are loaded from the other fixed disk drive. The system operating software determines which subsystems are loaded from each fixed disk drive.

The following conditions are assumed.

- That no cards fail during the loading process.
- All cards remain aligned on the **IMT** bus which allows the clock to start (no bus transition).
- The loading of gateway screening data is not included in the loading process.

Caution:

All **LIMs** are of one application type. The 5 minute loading requirement does not apply if both the **SS7ANSI** and **CCS7ITU** applications are being used on the **EAGLE**.

2.168 Enhanced STC Card Performance (Release 35.0)

Description

The Enhanced STC Card Performance feature increases the capacity of the STC card to 4,800 TVG grants per second. This allows MSUs on IP, low-speed, and high-speed links to be monitored for data feed to the Integrated Message Feeder (IMF). This feature applies to both the K6-II and K6-III variants of the SSEDCCM card.

Hardware Requirements

The Enhanced STC Card Performance feature has the following hardware requirements:

- A minimum of 2 STC cards must be provisioned in an EAGLE 5 ISS.
- A maximum of 32 STC cards can be provisioned in an EAGLE 5 ISS.
- A maximum of 3 STC cards can be provisioned in shelves that contain HMUX cards.
- The STC capacity of shelves that contain HMUX cards should be provisioned in adjacent shelves. Half of the STC capacity should be provisioned on the current shelf and the other half on either the previous or next shelf.
- Shelves where monitoring of IP links is performed must contain HIPR cards. The STC cards should be provisioned in the same shelf as the HIPR cards. If this does not occur, data feed is inhibited for IPLIMx/IPGWx, and an alarm is generated for each monitored link on the card.

Limitations

The Enhanced STC Card Performance feature has no limitations.

2.169 Enhancement to Backup TFR/TCR Procedures (Release 21.0)

TFR/TCR messages may be lost or not processed at a node due to a signaling link failure, congestion or other error conditions. Because of this, other nodes continue to send traffic over a restricted route. This results in C-link congestion. To help prevent this problem, the **TFR/TCR** procedures have been improved to send a second backup **TFR/TCR** once per linkset in response to messages received after the first **TFR/TCR**.

This feature is currently supported in the **EAGLE** (Release 3.3 and later) for **TFRs** with one exception.

When a **TFR** is generated because of internal congestion, as opposed to normal route failure, the **EAGLE** responds with one **TFR** for every 10 messages received. In Release 21.0, this has been changed so that after the first **TFR/TCR** is sent, the level 3 T18 timer is started. When the level 3 T18 timer expires, the **EAGLE** sends only one backup **TFR/TCR**.

This feature applies only to **ANSI** signaling links.

t a response being returned by the **EOAP**. If more than one message is sent to the **EOAP** without the **LSMS** waiting for a response, the **LSMS** must manage retries and the sequencing of messages.

The **EOAP** must be configured locally with the **LSMS OSI-Address** information necessary for association establishment. The **EOAP** will initiate association connections with the **LSMS**.

2.170 Enhancement to GSM ATI Query (Release 45.0)

The ATINP feature is enhanced to support ATI queries that request Location Information.

The `chg-atinpopts` command is used to provision the functionality to process Location Information requests and to format the Visitor Location Register number (**VLR-number**) in the Location Information field of the ATI ACK response message.

2.170.1 Feature Control Requirements

The ATINP feature must be enabled and turned on and the ATISUPPLOCINFO option must be provisioned in the `chg-atinpopts` command before an ATI query with a LocationInformation request can be processed.

2.171 Enhancement to GTT Failure Messages (Release 25.0)

Description

This feature enhances the current **SEAS REPT-NOTRNS** messages to include four optional parameters currently not supported in the **EAGLE** version of these messages.

- c4 - "Called Party Global Title Address"

- d1 - "Calling Party Address Type"
- d2 - "Calling Party Subsystem Number"
- d3 - "Calling party Address Point Code"

Effect on Existing UIMs

Implementation of this feature involves a minor change to one of the existing **EAGLE UIM** formats. To add the **CgPA** information to the **SEAS REPT-NOTRANS** message, 6 bytes of the **DATA** field I16 have been deleted. The format before and after the change is shown below; changes are shown in **bold**.

```

xxxx.xxxx   CARD cccc,p   INFO 'test'
             SIO=xx   OPC=###-###-###   DPC=###-###-###
             CDPA LENGTH=###   MSG TYPE=##
             CDPA:  AI=xx   PC=###-###-###   SSN=###   TT=###
ADDR=#####
             DATA=xx xx xx xx xx xx xx xx xx xx xx xx
                   xx xx xx xx xx xx
             LSN=[lnkset]
Format with new feature:
xxxx.xxxx   CARD cccc,p   INFO 'test'
             SIO=xx   OPC=###-###-###   DPC=###-###-###
             CDPA LENGTH=###   MSG TYPE=##
             CDPA:  AI=xx   PC=###-###-###   SSN=###   TT=###
ADDR=#####
             DATA=xx xx xx xx xx xx xx xx xx xx xx
                   xx xx xx xx xx xx
             LSN=[lnkset]
  
```

 **Note:**

The **DATA** field that is output begins with the **CdPA** part of the **MSU**. The **CdPA** part of the **MSU** is of variable length, but in most cases is organized as follows:

- 1st Byte - **CdPA** Length
- 2nd Byte - Address Indicator
- 3rd Byte - **SSN**
- 4th Byte - **Translation Type**
- Last 11 Bytes - **CdPA** Address

The following table lists the **UIMs** affected by this change, and use **UIM** format I16.

Table 2-43 Affected EAGLE UIMs

UIM #	Trouble Text
1029	SCCP rcvd inv Cld Party - bad GT ind
1033	SCCP rcvd inv Cld Party - bad network
1034	SCCP rcvd inv Cld Party - no SSN
1042	SCCP rcvd inv GT - bad Translation Type
1043	SCCP did not route - bad translation

2.172 Enhancement to the Prepaid IDP Query Relay Feature (Release 39.0)

The Prepaid IDP Query Relay (IDP Relay) feature is enhanced to provide a flexible configuration that allows:

- Modification of incoming calling party number (**CgPN**) and called party number (**CdPN**) digits for RTDB lookup
- The ability to request RTDB lookup for calling and called parties
- Flexible formatting of output numbers

The flexible configuration is achieved using the Numbering Plan Processor (NPP) to configure Services, Conditioning Actions, and Service Actions for the IDPR service.

2.172.1 NPP Modifications

The NPP modifications added to support the flexible configuration of the IDP Relay feature include:

- **Services**
The IDPRCDPN and IDPRCGPN services are added to provide CdPN and CgPN number conditioning and formatting for the flexible configuration of the IDP Relay feature.
- **Conditioning Actions**
The ACLAC Conditioning Action is added to update the AC and append the AC to the incoming digit string. This service action is supported by the IDPRCDPN service.
- **Service Actions**
The CDPNNP, LACCK, CCNCCHK, and CGPNNPRQD actions are supported by the IDPRCDPN service. The CGPNNP Service Action is supported by the IDPRCGPN service.

2.172.2 Feature Control Requirements

The IDP Relay feature has the following feature control requirements:

- A FAK for part number 893-0160-01.
- The GTT feature must be turned on before the IDP Relay feature can be enabled.
- If the LNP feature is enabled, then the IDP Relay feature cannot be enabled.

- The IDP Relay feature cannot be enabled if TSM cards running the SCCP application are present in the system.
- The IDPRCDPN NPP Service must be turned on before the IDP Relay feature can be turned on.
- Once the feature is turned on, it cannot be turned off.
- A temporary FAK cannot be used to enable the feature.

2.172.3 Hardware Requirements

The flexible configuration of the IDP Relay feature does not have any additional hardware requirements. The existing IDP Relay feature cannot be enabled if TSM cards running the **sccp** application are present in the system. If a TSM card is inserted after the feature is enabled, then the card auto-inhibits.

2.172.4 Limitations

No limitations are associated with this feature.

2.173 Enhancements to GWS Reject Messages (Release 25.0)

Description

This feature enhances the current **SEAS REPT-SCRREJ** message to include two optional parameters currently not supported in the **EAGLE** version of these messages. The two optional parameters are:

- `rec` - "Rejection Error Code"
- `z` - "Supplier-Specific Parameter Text"

SEAS Compliance

The following table maps **EAGLE** rejection reasons to the **SEAS** rejection error codes.

Table 2-44 EAGLE-to-SEAS GWS Rejection Mapping

EAGLE Gateway Screening Reject Reason (RPT_MRN_GWS_...)	EAGLE Supplier-Specific Parameter Text in the "z" Field	SEAS Code	SEAS Reject Code Meaning (per GR-778)
OPC_NOT_ALLOWED	"GWS rcvd OPC that is not allowed"	ONNV	OPC not valid
OPC_BLOCKED	"GWS rcvd OPC that is blocked"		
DPC_NOT_ALLOWED	"GWS rcvd DPC that is not allowed"	DNNV	DPC not valid
DPC_BLOCKED	"GWS rcvd DPC that is blocked"		
SIO_FAILED	"GWS rcvd SIO that is not allowed"	SINV	SI not valid
	No EAGLE Equivalent	NINV	NIC not valid
PRIORITY_FAILED	"GWS rcvd a priority that is not allowed"	PRNV	PRI not valid

Table 2-44 (Cont.) EAGLE-to-SEAS GWS Rejection Mapping

EAGLE Gateway Screening Reject Reason (RPT_MRN_GWS_...)	EAGLE Supplier-Specific Parameter Text in the "z" Field	SEAS Code	SEAS Reject Code Meaning (per GR-778)
H0H1_FAILED	"GWS rcvd H0/H1 that is not allowed"	HCNV	H0 or H1 not valid
CLG_FAILED	"GWS rcvd Clg Party that is not allowed"	CGNV	CgPA PC or SSN not valid
	No EAGLE Equivalent	LGNV	CgPA/link set combination not valid
	No EAGLE Equivalent	RINV	CdPA routing indicator not valid
CLD_FAILED	"GWS rcvd Clid Party that is not allowed"	CDNV	CdPA SSN or DPC not valid
DESTFLD_NOT_ALLOWED	"GWS rcvd AFTPC that is not allowed"	DFNV	Affected destination field not valid
SCMG_APC_FAILED	"GWS rcvd SCMG with not allowed AFTPC"	AFNV	Affected PC/SSN not valid
	No EAGLE Equivalent	FINV	SCMG format ID not valid
GT_TYPE_FAILED ALLOWED_TT_FAILED	"GWS rcvd Translation Type not allowed"	TTNV	TT not valid
	"GWS rcvd invalid GTI in TT Screening"		
	No EAGLE Equivalent	ISNV	ISUP message type not valid
TFC_APC_FAILED	"GWS rcvd TFC, AFTPC not in routing tbl"	OTNV	Message rejected for a reason not identified by any of the other "rec" field values.
RSP_APC_FAILED	"GWS rcvd RSP, AFTPC not in routing tbl"		
RSR_APC_FAILED	"GWS rcvd RSR, AFTPC not in routing tbl"		
TCA_APC_FAILED	"GWS rcvd TCA, AFTPC not in routing tbl"		
TCP_APC_FAILED	"GWS rcvd TCP, AFTPC not in routing tbl"		
TCR_APC_FAILED	"GWS rcvd TCR, AFTPC not in routing tbl"		
TFA_APC_FAILED	"GWS rcvd TFA, AFTPC not in routing tbl"		
TFP_APC_FAILED	"GWS rcvd TFP, AFTPC not in routing tbl"		
TFR_APC_FAILED	"GWS rcvd TFR, AFTPC not in routing tbl"		
UPU_APC_FAILED	"GWS rcvd UPU, AFTPC not in routing tbl"		

2.174 Enlarged LNP SPID and NPANXX Support (Release 24.0)

The Enlarged **LNP SPID** and **NPANXX** Support increases the maximum number of service provider **IDs (SPID)** and **NPANXXs** that can be configured in the database.

The maximum number of service provider **IDs** is increased to 10,000. If you try to enter more than 10,000 service provider **IDs** with either the `ent-lnp-sp`, `ent-lnp-sub`, or `ent-lnp-lrn` commands, the attempt will be rejected with this message.

Error Messages

```
E3133 - LNP Service Provider Table is full
```

The maximum number of **NPANXX** entries is increased to 150,000. If you try to enter more than 150,000 **NPANXXs** with either the `ent-lnp-npanxx`, `ent-split-npa`, `ent-lnp-sub`, or `ent-lnp-lrn` commands, the attempt will be rejected with this message.

```
E3138 - LNP NPANXX Table is full
```

RTRV-LNP-SP Command

The parameters `num`, `force`, and `sp` have been added to the `rtrv-lnp-sp` command to control the number of entries in the service provider **ID** table that are displayed. Refer to the *Commands Manual* for current usage information.

2.175 ENT-CARD Enhancement (Release 46.0)

ENT-CARD Enhancement feature enhances the `ent-card` command to provision new applications for EAGLE cards.

2.176 Entering a Global Title Translation to a Non-Mated Application without Adding the Application as Mated Application (Release 22.0)

In Release 22.0, a global title translation can be entered to a non-mated (solitary) application, either through an **EAGLE** terminal or the **SEAS** interface, without requiring the application to be defined by the **EAGLE's** `ent-map` command.

The `force` parameter (valid values `yes` or `no`) has been added to the **EAGLE's** `ent-gtt` command that allows the user to override the rules that make sure that the application is defined in the mated application table. The default value for the `force` parameter is `no` for the **EAGLE's** `ent-gtt` command. If a global title translation is being added from the **SEAS** interface, the default value for this parameter is `yes`.

When a global title translation is entered on the **SEAS** interface, the **EAGLE** does not check to see if the specified application is defined in the mated application table.

If the global title translation is a final global title translation, the application being referenced by the global title translation must be in the mated application entity set. If the global title translation is being entered on an **EAGLE** terminal with the `ent-gtt` command, the `force=yes` parameter is not specified, and the mated application is defined the mated application table, the command is rejected with the following error messages.

```
E2450 Cmd Rej : PC/SSN does not exist as a mated application
```

```
E2419 Cmd Rej : Point code does not exist in the remote point code table
```

If the `force=yes` parameter is specified with the `ent-gtt` command and the specified application is required to be defined in the mated application table, the following warning messages are displayed.

```
CAUTION - DPC-SSN does not exist in the Mated Application table.
```

```
CAUTION - DPC does not exist in the Mated Application table.
```

If the final global title translation is entered on the **SEAS** interface, the rules checking the mated application table do not apply.

2.177 ENUM Enhancement to update ENUMPROF table

The ENUM feature has been enhanced to add another regular expression format to be sent to the ENUM client in the NAPTR response. The regular expression is modified as follows:

- The DEFCC and RN from the NPDB lookup are inserted before the called party DN, as “sip: +<DEFCC><RN from the NPDB lookup><Called Party DN>”
- The DEFCC and PREFIX parameter configured in the ENUM Profile Table are inserted after RN tag as “rn=+<DEFCC><PREFIX>”.

The resulting regular expression format will then be:

```
sip: +<DEFCC><RN from the NPDB lookup><Called Party  
DN>;npdi;RN=<+DEFCC><PREFIX configured in ENUM Profile Table>@<domain name  
defined in ENUM Profile Table>
```

This regular expression format will be used when the NAPTR service as configured in the ENUM Profile Table is PSTNSIP and the new INCPREFIX option as configured in the ENUM Options Table is YES.

The maximum number of entries allowed in the ENUM DN Block Profile Table has been increased from 2048 to 4096.

The `chg/ent/rtrv-enum-prof` and the `chg/rtrv-enumopts` commands were updated to support this enhancement.

See *Feature Description* in *ENUM User's Guide* for more information.

2.178 ENUM on SLIC Network Redundancy Enhancement (Release 46.5)

This feature introduces network communication redundancy on the SLIC card. Four network interfaces will support ENUM - two for EPAP communication and two interfaces for signaling. One SLIC card running the ENUM application can connect to two EPAPs and two signaling networks at the same time. Interface A/D is used for EPAP connectivity, and interface B/C is used for the signaling network.

Figure 2-36 ENUM on SLIC Network Redundancy Model

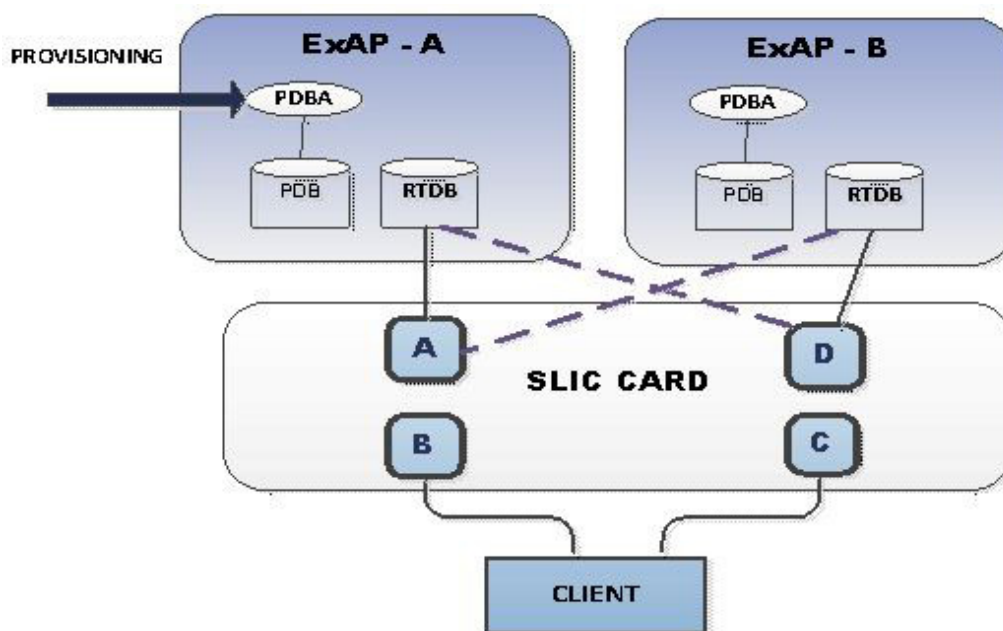

See *ENUM User's Guide* for more information.

2.178.1 Hardware

Ethernet Interface A and D are used for EPAP connectivity on SLIC cards.

Ethernet Interface B and C will be used for signaling network connectivity on SLIC cards.

2.179 EOAP/OAP Support of HSOP Protocol (Release 28.0)

The **EOAP/OAP** currently supports only the Q.3 interface to the **LSMS**. The **ELAP** supports the **HSOP** interface to the **LSMS**. From an internal perspective, it is advantageous for the **LSMS** to support a single interface to the **EAGLE**, regardless of the architecture deployed. This feature achieves a single interface by requiring the **OAP/EOAP** to support the **HSOP** protocol.

HSOP is a fast, reliable protocol developed by Tekelec. **LSMS** Release 5.0 will support one **HSOP** protocol to communicate with **EAGLE** release 28.0 and future **EAGLE** releases.

LSMS EAGLE Communication Overview

Prior to release 5.0, **LSMS** supported two different protocols to communicate with pre-28.0 **EAGLE** releases.

Figure 2-37 LSMS EAGLE Protocol Interface for Pre-5.0 LSMS Releases and pre-28.0 EAGLE Releases

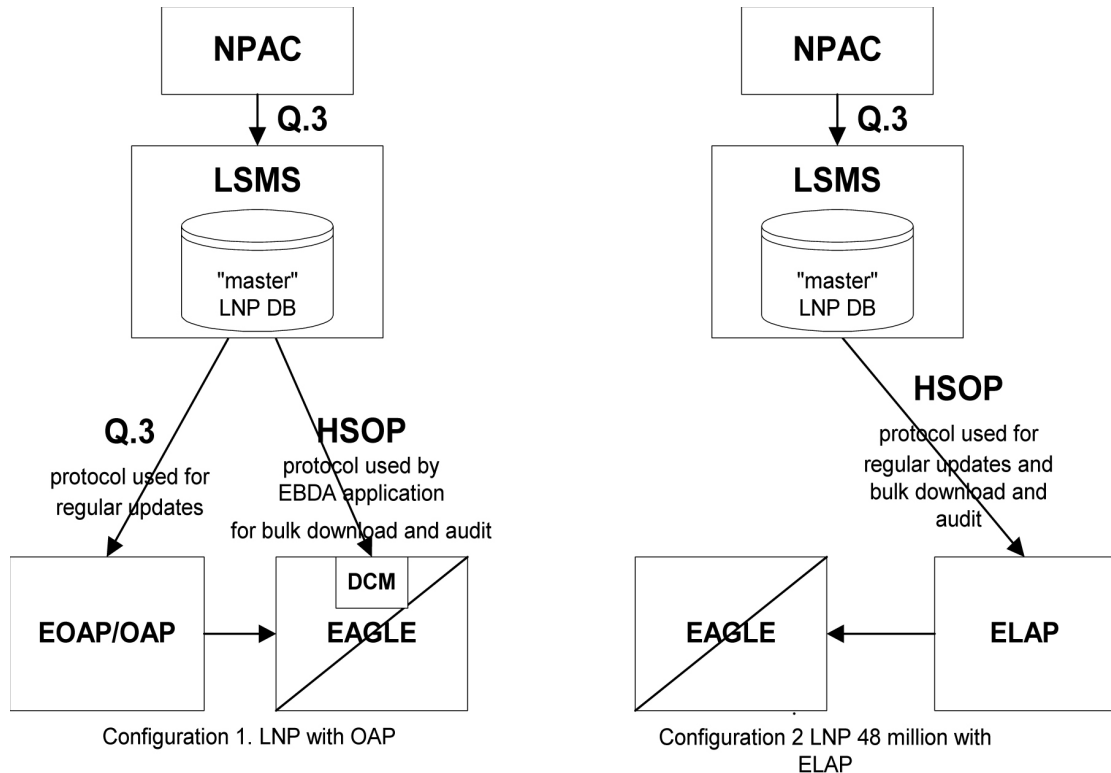

The Q.3 protocol is used by **LSMS** to communicate with **EOAP/OAP**. **HSOP** protocol is used by the **EBDA** process to send information to **DCM** cards on **EAGLE**. Enhanced **HSOP** protocol is used to communicate with the **ELAP** when the 48 Million feature is enabled.

EOAP/OAP Overview

EOAP/OAP (OSS Application Processor) was developed to provide telephone company network management systems access to the **EAGLE STP**. **SEAS (Signaling Engineering and Administration System)** provides network management functionality. **EOAP/OAP** interfaces with **SEAS** using Telcordia standards and licensed code.

EOAP/OAP software consists of few a processes running on the Solaris 2.5.1 **UNIX** operating system. With the introduction of the **LNP (Local Number Portability)** feature, **EOAP/OAP** was extended to provide the communication channel for updates sent from **LSMS** to **EAGLE LNP** database using Q.3 protocol.

EOAP/OAP consists of 11 processes. Some processes provide **SEAS** access to **EAGLE**; others process **LNP** database updates sent from **LSMS** to **EAGLE**. **LNP** database updates are sent from **LSMS** using the Q.3 protocol to the **EOAP/OAP** emsAgent process.

The purpose of the `emsAgent` process is to translate Common Management Information Protocol (**CMIP**) messages from the **LSMS** M-Actions into **TL-1** commands that can be interpreted on the **EAGLE** by the **UPL** parser.

HSOP replaces the Q.3 protocol, and `hsopAgent` replaces the `emsAgent` (see figure). The `hsopAgent` process translates **LSMS HSOP** commands to **TL-1** commands that can be interpreted on the **EAGLE** by the **UPL** parser. The new `hsopAgent` provides the same interface to the `ysTTY` process and the `ysT1mnt` process. It is seamlessly integrated with current **EOAP/OAP** software; it does not require special configuration to run properly.

New Hardware Required

No new hardware is required for this feature.

2.180 EPAP 2.0 Alarm Migration from ELAP (EAGLE 28.0)

This **EAGLE 28.0** feature converts **EPAP** message notification and alarming from the type previously used in **EPAP 1.0** to the type used in **ELAP 2.0**.

As revised, **EPAP 2.0** employs different **EAGLE UAMs**, uses the **MPS** System Health Check (`syscheck`) utility to diagnose and report **MPS/EPAP** platform problems, and uses **MPS LEDs** more completely.

For additional details, refer to the *EPAP Administration Manual* and the *Maintenance Manual*.

2.181 EPAP Automated Database Recovery (EPAP 7.0)

Description

The **EPAP** Automated **Database** Recovery (**ADR**) feature is used to restore the **EPAP** system function and facilitate the reconciliation of **PDB** data following the failure of the Active **PDBA**.

The automated recovery mechanism provided by this feature allows 1 **PDBA** to become Active when 2 **PDBAs** think they are active and have updates that have not been replicated to the mate **PDBA**. The software selects the **PDBA** that received the most recent update from its mate to become the Active **PDBA** (the **PDBA** that was the Standby most recently will become the Active). No automatic reconciliation is performed because the system has insufficient information to ensure that the correct actions are taken.

In order to return the system to normal functionality, a manual **PDB** copy from the **PDBA** the software picked to be Active to the **PDBA** that is in the replication error (`ReplErr`) state must be performed. However, provisioning can resume until a maintenance period is available to do this.

This feature uses a replication error list that consists of updates that exist as a result of a failure during the database replication process from the active-to-standby **PDB**. These updates have not been propagated (reconciled) throughout the system and require manual intervention to ensure the **EPAP** systems properly process the updates.

Limitations

1. The **EPAP ADR** feature can be turned on or off. The default setting is off.
2. The **EPAP ADR** feature must be turned on for both **MPS-A** boxes of an **MPS** pair.
3. The **EPAP ADR** feature requires Standby-homing to be active. If Active-homing is being used by the customer, **DSM** re-boots may be required if they have taken updates from the Active **PDB** that are different from what has been replicated to the Standby **PDB**.
4. Each **EPAP** can support a minimum of two replication error lists.

2.182 EPAP Command Response Enhancement (Release 31.6)

This feature provides users of the **PDBI** with the ability to retrieve information about the status of the **DSMs** in their network. This information includes, but is not limited to, the database level of each card. The **DSM** database level is of specific importance because the customer can use it to determine when a specific update has made its way to most or all of the **DSM** cards.

This new information will be made available to **PDBI** clients through new asynchronous notifications and synchronous requests/responses. New WebUI screens that utilize the new **PDBI** messages are also created for displaying the **DSM** information.

In order to propagate the **DSM** information up from the **DSM** to being available through the **PDBI**, the **DSM** code as well as several processes in the **EPAP** are changed.

2.183 EPAP DN Block Capacity Increase (Release 46.0)

The EPAP DN Block table capacity is increased from 100,000 DN Blocks to 200,000 DN Blocks. This table capacity increase is necessary to support large network requirements and the additional DN Blocks created by the Self Healing DN Block feature.

2.184 EPAP Expansion to 480M Database Entries (Release 16.1)

The Oracle Communications EAGLE Application Processor (EPAP) Expansion to 480M Database Entries feature allows an EPAP on an E5-APP-B with a 480G disk to support 240 million Directory Numbers (DNs) and 240 million International Mobile Subscriber Identities (IMSI). In addition, the feature allows for the support of 48 million International Mobile Entity Identities (IMEIs). The combination of 240 million DN, 240 million IMSI, and 48 million IMEI brings a maximum combination of 528 million data. This feature is supported on all EPAP configurations: Mixed EPAP, Standalone PDB, and Non-Provisioning EPAP.

Note:

For the feature to work, the 480M Capacity License must be purchased, with the license capacity manually set to 480M in the EPAP. See alarm "6000000000400000 - License capacity is not configured" in *Alarms and Maintenance Guide* for potential failure of configuration information and recovery.

The following table illustrates RTDB capacity support:

Table 2-45 EPAP DB Capacity Combinations

EPAP Split DB Feature	EPAP240M	Card Provisioned	Max Entries
OFF	OFF	SM4G	135M
OFF	OFF	SM8G	135M
ON	OFF	SM4G	255M
ON	OFF	SM8G	255M
OFF	ON	SM8G	288M
ON	ON	SM8G	528M (240M DN + 240M IMSI + 48M IMEI)

2.184.1 Hardware

The Expansion to 480M Database Entries feature is supported on the EPAP application on an E5-APP-B card with a 480G disk. The PDB capacity is configured as 255M on an E5-APP-B-01 card and 528M on an E5-APP-B-02 card.

2.185 EPAP Feed to External Query Server (EPAP 16.0)

The EPAP Feed to External Query Server feature allows the EPAP to provide a copy of the EPAP Provisioning Database (PDB) to an External Query Server to allow offline query support of the Number Portability database. The Query Server data is synchronized using MySQL 5.6 Replication. A Query Server can connect to only one EPAP. More than one Query Server can be deployed in the system in a master-slave relationship, also known as daisy-chained Query Servers.

2.186 EPAP on T1200 Application Server (EPAP 13.0)

The EPAP on T1200 Application Server feature provides the ability to run EPAP on both the T1000 and T1200 Application Servers. When running on T1000, hubs are used, and when running on T1200, Telco GigE switches are used.

When running on a T1200 AS, a minimum of two switches are needed to support up to 17 Service Module (SM) cards. A maximum of four switches are supported, which in turn support up to 32 SM cards per node.



Note:

EAGLE 5 ISS Release 41.1 supports 24 SCCP cards or less.

EPAP to SM Card Network Support

This feature, when running on a T1000 AS, supports SM cards running at 100Mbps at half duplex on side A, and 10Mbps at half duplex on side B, regardless of the type of SM cards used.

When running on a T1200 AS, the speed is determined by specific card combinations:

1. A T1200 AS running with only DSM Cards:
 - a. On side A: 100 Mbps and half duplex
 - b. On Side B: 10 Mbps and half duplex
2. A T1200 AS running with only SM4G Cards
 - a. On side A: 100 Mbps and full duplex
 - b. On Side B: 100 Mbps and full duplex
3. A T1200 AS running with a mixture of DSM and SM4G cards: (since each individual port on the switch is not configured, the switch is set to run at the DSM card's rate)
 - a. On side A: 100 Mbps and half duplex
 - b. On Side B: 10 Mbps and half duplex

Removal of Man-Machine Interface (MMI) Connectivity on T1200 AS

Due to the lack of serial ports on the T1200 AS, the MMI Connection shall be removed when the feature is running on a T1200 AS. The MMI connection is still available when the feature is running on a T1000 AS.

Hardware Requirements

Either a T1000 AS with hubs or a T1200 AS with switches is required.

Limitations

This feature requires TPD version 3.3.2 and MySQL version 5.0.37.

T1200 AS will not function with hubs that are already in place with a T1000 setup.

2.187 EPAP PDB-RTDB Level Threshold (Release 31.6)

Currently, the amount of time used to determine if the **RTDB** is too slow on getting updates (alarm is raised) is configurable using the **RTDB->Maintenance->Configure Record Delay** menu. **uiEdit** or the **cgi** script interface can be used to change this value from the default value of 15 to any value between 1 and 300.

The mate **PDBA** is configurable via the new menu (**PDBA->Maintenance->Configure PDBA Record Delay**.) The **PDBA** threshold may also be changed (by development/cust service only) by using **uiEdit** to change the value of **PDBA_MAX_STANDBY_DELAY** - which is defaulted to 300.

2.188 EPAP Performance on E5-APP-B (EPAP 15.0)

For EPAP 15.0 on the E5-APP-B card, the performance of various provisioning commands is available in the *EPAP Provisioning Performance* section of *EPAP Administration Manual*.

2.189 EPAP Provisioning Blacklist (EPAP 7.0)

Description

The **EPAP Provisioning Blacklist** feature helps prevent provisioning of protected address strings in the **EPAP** database. Provisioning a protected address string as a **DN**, **DN Block**, or **IMSI** may result in unintended and incorrect routing of messages by the **EAGLE 5 ISS DSM**.

The **EPAP Provisioning Blacklist** feature allows the user to define a list of address strings that cannot be provisioned as **DN**, **DN Block** or **IMSI** address strings. The addresses of all **HLRs** must be provisioned in the provisioning blacklist in order for the **EPAP Provisioning Blacklist** feature to work as intended.

A maximum of 150 blacklist ranges is supported by **EPAP**. A blacklist range is defined by two address strings. The beginning and ending address strings used to define a blacklist range must be between 5 and 15 **HEX** digits. In addition, both address strings must be of the same length.

The ending address must be greater than or equal to the beginning address and must not conflict with **DN**, **DN block**, or **IMSI** values in the **PDB**.

Limitations

The **EPAP Provisioning Blacklist** feature has the following limitations:

- The blacklist ranges are stored in the **PDB** database. Since modification of blacklist data is not supported via the **PDBI (Provisioning Database Interface)**, support of **PDBI** export and import is not possible. In addition, modification of existing blacklist data is not supported.
- If the blacklist does not include all protected address strings in a customer network, and one of the protected address strings is provisioned as a **DN**, **DN Block**, or **IMSI**, unintended message routing occurs, and may cause network outages.

2.190 EPAP Provisioning Performance Enhancements (Release 29.0)

Description

The Enhanced **EPAP** Provisioning Performance feature replaces **FTS** with an asynchronous replication scheme. **FTS** (Fault Tolerant Server) is a protocol used by Versant to achieve data synchronous replication.

EPAP 1.0 and 2.0 provided support for **MPS** provisioning databases spanning two sites, with each site hosting a database whose data is replicated synchronously to the other via **FTS**. To ensure synchronous replication of data, this transfer protocol requires that 8 messages be exchanged per update.

Messaging and data exchange must take place over potentially slow customer network. When the customer network is slow (that is, there exists a network latency issue between the two customer sites containing **PDBs**, such that the round trip delay between sites exceeds 4-5 ms.), the messaging overhead can cause provisioning rates to drop to unacceptable levels.

Asynchronous replication means that the database receiving an update, in this case the Active **PDB**, can commit and send the client a success or failure code prior to sending the update to the replicated database, in this case the Standby **PDB**. Note that only successful updates are replicated. Response turnaround on the Active **PDB** is thus shortened, and the overhead involved in keeping the databases in sync is spared.

With this feature, the round trip time between nodes may be up to 100 ms. without encountering active/standby lag problems.

Single Transaction Mode PDBI Connection

In **EPAP 1.0** and **2.0**, all **PDBI** provisioning commands had to be encapsulated in 'begin' and 'end' transaction statements. Many customers, however, wanted only to send one update per transaction. In such a case, the overhead involved in sending transaction boundary tags can become considerable.

In **EPAP 3.0**, a new **PDBI** connection type called 'single transaction mode' is provided. When using this connection type, **PDBI** clients are allowed to send updates outside of 'begin' and 'end' transaction delimiters. The **PDB** treats each update as being its own transaction. However, transaction delimiters are not ignored in 'single mode'. If the **PDBI** client issues these delimiters, the series of updates encapsulated by them will be treated as one transaction, as they always have been under the default **PDBI** connection mode.

Hardware Requirements

No new hardware is required or introduced to support the software.

Enhancements to the User Interface

A new state has been added to the set of **PDBA** states displayed by the Web **UI** Banner. This state, entitled "**REPLERR**," denotes the presence of alarm **MAINT_ALARM_PDBA_REPL_FAILED**. **REPLERR** may also appear on the View **PDBA** Status page, and the View **RTDB** Status page.

Upgrade Considerations

During upgrade, the Versant replica file, if present on the **MPS**, will be moved to a different location so that **FTS** will not be active in **EPAP 3.0**. Upon removal of the **EPAP 3.0** application package, this file will be set back in its original location, so that the system may resume use of **FTS** following a backout. If updates have been made to the **PDB** following upgrade, however, backout will entail full **PDB** restoration. Otherwise, this feature will not affect the **EAGLE 28.x/EPAP 2.x** to **EAGLE 30.0/EPAP 3.0** upgrade.

Limitations

These enhancements introduce an important change to the behavior of **EPAP**. **PDBA** switchover can no longer be forced while the **PDBAs** are able to communicate and the Standby is behind. Switchover now entails allowing some definable amount of time for the Standby **PDB** to be brought up to the level of the Active **PDB**. If it fails to obtain equal database level in the allotted time, switchover will not occur, and it will return with the number of levels still left to be replicated. This is a safeguard designed to prevent database inconsistency. However, if the Standby **PDB** cannot reach the Active **PDB** to determine its level, then the **EPAP** will allow **PDBA** switchover to be forced.

2.191 EPAP RTDB Level Auto Refresh (Release 31.6)

This feature provides a configurable auto refresh rate for the `viewPDBAStatus.cgi` and `viewRtdbStatus.cgi` screens. Users are able to halt the refreshing without losing the information displayed on the screen at the time (for debugging or capturing data).

A new field is added to the Modify Defaults screen that takes a value of 0 or 5-600 seconds. This determines if (0 means no refreshing) the **PDBA** and **RTDB** View Status pages are refreshed and how often. On the screen, this value can be modified, but reloading the screen using the left-most menu links causes the system default to be changed. The system default applies to both screens.

2.192 EPAP Security Enhancements (Release 29.0)

Description

The **EPAP** Security Enhancements feature implements a database table of **IP** addresses that can be added to, deleted from, and retrieved by an authorized user.

The Admin user or user possessing **IP** action privileges can at any time add, delete, and retrieve **IP** addresses. Deletion of an **IP** would cause that **IP** address to no longer reside in the **IP** table, and therefore would no longer be able to connect to the **EPAP 3.0 GUI**. While each of the **IP** action privileges can be assigned individually to a user, the **IP** action privileges of add and delete should only be granted to those users with knowledge of the customer network.

The functionality for addition, deletion, retrieval of client **IP** addresses, and toggling of **IP** authorization checking are individually assignable and accessible only through the **EPAP 3.0 GUI**. The **IP** mechanism implemented in this feature will provide a foundation for further enhancements in privilege control.

The new **IP** actions of add, delete, retrieval, and toggling of **IP** authorization checking are available only through the **EPAP 3.0 GUI**, and added initially to the Admin group only. The privilege of viewing **IP** addresses on the customer's network should be a security consideration made only by a user with Admin Group privilege. Privileged users can add a custom message in place of the standard 403 Forbidden site error.

Note:

The **IP** actions of this function that allow for adding, deleting, retrieving authorized **IP** Addresses, and the toggling of authorized **IP** checking are **NOT** accessible from the **EPAP 3.0** text-based **UI**. They are accessible from the **EPAP 3.0 GUI** only. No **IP** addresses are restricted from accessing the **EPAP 3.0 GUI** until the Admin user toggles **IP** authorization to enabled. When **IP** authorization checking is enabled, all **IP** addresses not present in the **IP** authorization list will be refused access to the **EPAP 3.0 GUI**.

Hardware Requirements

No new hardware is needed to support this feature.

Upgrade Considerations

This feature will impact the **EPAP 1.x/2.x** to 3.0 upgrade.

Limitations

IP access and range constraints provided by web server and **EPAP 3.0 IP** address checking functionality will not protect against **IP** spoofing . The customer must rely on the security of the customer intranet network to protect against spoofing.

2.193 EPAP Support for HTTPS on GUI (EPAP 9.0)

Description

The EPAP Support for HTTPS on GUI feature allows users to configure whether the GUI can be accessed only by standard HTTP (Hypertext Transfer Protocol) or only by HTTPS (Secure Hypertext Transfer Protocol) or by both.

In previous releases of EPAP, the EPAP GUI used only standard HTTP protocol. The data transfer between the web server and the GUI is not encrypted with standard HTTP protocol; therefore, it can be captured by any network analyzer and viewed. Secure HTTP (HTTPS) supports encryption of data exchanged between the web server and the browser. This facilitates data privacy.

With the addition of this feature, the EPAP now allows the user to configure the use of either HTTP or HTTPS, or both, for the EPAP GUI. The user can disable HTTP. The ability to configure HTTP and HTTPS and the ability to disable HTTP can be limited to a specific user class or group.

When the HTTPS interface is used for the first time, the security certificate needs to be imported to the client machine. For information about importing the secure certificate, refer to the *EPAP Administration Manual*.

Hardware Requirements

None.

Limitations

None.

2.194 EPAP Support for SSH on PDBI (EPAP 9.0)

Description

The EPAP Support for SSH on PDBI feature provides support for Secure Shell (SSH) on the EPAP Provisioning Database Interface (PDBI) for customers who want additional security protection.

SSH is a robust, commercial-grade, and full-featured toolkit that implements security and network encryption.

In previous EPAP releases, the customer provisioning application (CPA) connected to the EPAP only through a non-secure TCP/ IP connection. Provisioning sent by the CPA was non-secure, because the data was not encrypted and could be seen by packet sniffers in the network.

To make the data transfer between the CPA and the PDBA (Provisioning Database Application) machine secure, SSH tunneling (also called remote port forwarding) is used to securely connect the PDBA machine to the CPA machine.

Figure 2-38 SSH Tunnel Between the CPA and PDBA Machines

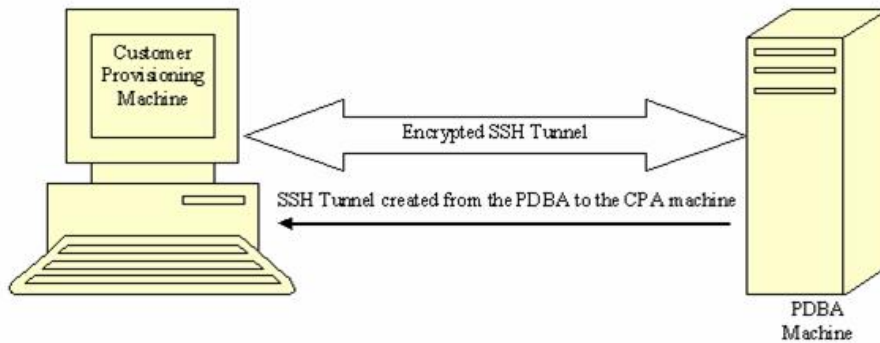

Remote Port Forwarding

Remote Port Forwarding refers to the SSH tunneling approach where the SSH tunnel is created from the client side of the tunnel towards the server side. In the EPAP implementation, the CPA machine is the server and the PDBA machine is the client.

The PDBA machine user specifies a particular port number (configurable from GUI) to be opened on the CPA machine. Any data received on this port on the CPA machine is forwarded to the PDBA machine's IP address and the port number, 5873, through the secured SSH tunnel.

Note:

To implement Remote Port Forwarding to work, the CPA machine must have the OpenSSH suite installed and the SSH daemon must be running.

Request/Response Cycle in SSH Tunnel

When an SSH tunnel is in use, a complete request and response cycle takes place as follows:

1. When an SSH tunnel is in use, a complete request and response cycle takes place as follows:
2. The CPA sends a connect request to its local port number used for creating the tunnel.
3. The SSH encrypts the request message and sends it to the PDBA machine's SSH client port.

4. On the PDBA machine, the SSH client decrypts the message and forwards it to the PDBA port.
5. The SSH client encrypts the response message and sends it to the SSH port on the CPA machine.
6. On the CPA machine, the SSH daemon decrypts the message and forwards it to the CPA. The CPA receives the message unencrypted.

Hardware Requirements

None.

Limitations

This SSH tunneling feature works only for customer provisioning systems with 'Write' permissions. A system with 'Read' permissions is not allowed to use the SSH tunnel with the PDBA machine.

2.195 EPAP Support of EAGLE's ITU Duplicate Point Code (Release 29.0)

Description

The **EAGLE's Duplicate Point Code** feature allows point codes to be provisioned in the **EAGLE** using a two character "group code." For example, a point code of 1-1-1 could be provisioned 1-1-1-ab, where 1-1-1 is the true point code and ab is the group code. This allows the **EAGLE** to route between two nodes that have the same true point code. The **EAGLE** distinguishes between the two by the group code. The group code is only used internally to the **EAGLE**, and is assigned to an incoming message based on the linkset on which it was received.

Currently, the **PDBI (Provisioning Database Interface)** does not support entering point code with a group code. This presents a problem for some customers running the **DPC** feature and either **G-Flex**, **G-Port**, or **INP**.

The **EPAP Support of EAGLE's ITU Duplicate Point Code** feature allows group codes to be entered for Network Entity (i.e. **SP** or **RN**) point codes via the **PDBI**.

The following components are affected by this feature:

1. **Provisioning Database Interface.** Messages related to Network Entity update, create and retrieve will have new optional name value pair called gc for group code.
2. **Provisioning Database.** **EPAP** database schema will change. New element gc for group code will be added
3. **Provisioning Database Application.** Parsing routines will change to accommodate group code.
4. **PDBA-RTDB** interface will change to accommodate new group code parameter.
5. **Real Time Database.** Parsing and storing of new data
6. **EPAP User Interface PDB** Network Entity screens will add new group code field.
7. **EPAP 1.0/2.0 to 3.0** data base migration

Hardware Requirements

No new hardware is needed to support this feature.

Upgrade Considerations

Seamless database upgrade (Versant utility sch2db) path from **EPAP 2.0** to **3.0** will be used if possible; otherwise, database migration procedure shall be provided. Migration procedure will not take more than 10 minutes with maximum of 50K entries in Network Entity class.

Limitations

This feature extends, and is dependent upon, **EAGLE's ITU DPC** feature.

2.196 EPAP Update Validation (EPAP 7.0)

Description

The EPAP Update Validation feature provides additional data checks (checksums) before applying updates from the **EPAP RTDB** to the **DSM RTDB**.

These additional checks are designed to prevent overwriting of existing data records with new data records when operators are provisioning new subscribers.

When update validation is triggered, the **DSM** card goes **DB-DIFF** not incoherent. **DB-DIFF** requires a reload of the **DSM** card. However, the **DSM** card will continue to process traffic until it is reloaded.

A checksum of the data about to be overwritten is compared with the old checksum (new data element) in the update about to be applied as well as the existing memory location check. If the checksums and location do not match, the update will not be applied to the **DSM RTDB** and the **DSM** will go incoherent.

To use this feature, the **EAGLE 5 ISS** will first need to be upgraded to Release 34.0.4. The **DSM** cards will continue to accept and process update records from the **EPAP** that do not contain the update validation information. After the **EAGLE 5 ISS** is upgraded, the respective **EPAP** is upgraded to provide the update validation information. The **DSM** cards will provide information to the **EPAP** that details whether or not it can accept and process update validation information (based on the **EAGLE 5 ISS** software level) from the **EPAP**.

2.197 EPAP with TPD 1.1 (Release 31.6)

MPS now uses Tekelec Platform Distribution (**TPD**) Release 1.1, which offers the following improvements over **TPD** Release 1.0:

- An additional diagnostic service, `smartd`, has been added. The `smartd` service reads status information from the disk (produced according to the S.M.A.R.T. standard) and reports that status through the `syscheck` utility. The standard S.M.A.R.T. (Self-Monitoring, Analysis and Reporting Technology) technology is implemented into all modern hard disks. According to this standard, a special program inside the disk constantly tracks the condition of a number of the vital parameters, such as driver, disk heads, surface state, electronics, etc. At the

present time, S.M.A.R.T. technology is able to predict up to 70% of all hard disk problems.

- Various changes that make the platform easier for the **EPAP** application to use (these changes do not result in changes that are noticeable by the user).

2.198 EPAP/ELAP 2.0 Security and UI Enhancements (Release 28.0)

Description

This feature allows the customer to access **ELAP** and **EPAP** functionality from any computer workstation capable of supporting an Intranet connection and Microsoft's Internet Explorer 4 browser. This feature does not change major **ELAP/EPAP** functionality. It does, however, provide Client/Server architecture and a new menu interface to that functionality.

This feature provides a new user interface and presents no impact to the **EAGLE**. The old text-based **UI** is available for provisioning purposes.

For more information on the **EPAP/ELAP** Security and **UI** Enhancements, refer to the **EPAP Administration Manual** or the **ELAP Administration Manual**, and the *Maintenance Manual*.

Hardware Requirements

Customers need a **PC** that can connect to the **LAN/WAN**.

2.199 EPM-B Based Cards(Release 44.0)

A new Embedded Processor Module (EPM) is introduced. This module is referred to as the EPM-B and has a Part Number of 850-2037-01.

A series of new cards that run on the EPM-B is introduced. These cards are known collectively as EPM-B based cards and are discussed individually in their associated sections:

- [E5-ATM-B \(Release 44.0\)](#)
- [E5-ENET-B \(Release 44.0\)](#)
- [E5-MCPM-B \(Release 44.0\)](#)

The EPM-B based cards are single slot cards with dual core processors.

2.199.1 Hardware Requirements

- Fan trays must be installed on shelves that contain EPM-B based cards.
- The IMT bus must contain at least one HIPR or HIPR2 card before an EPM-B based card can connect with the bus. If HMUX cards are used, then the cards cannot access the IMT bus. If the shelf contains both HMUX and HIPR/HIPR2 cards, then the EPM-B based card connects with the HIPR/HIPR2 cards only.

 **Note:**

HMUX cards with HIPR/HIPR2 cards on the same shelf are supported only during migration to the EPM-B based cards.

- Dual 60A power feeds are recommended for all frames that host EPM-B based cards. EAGLE 5 frames that host EPM-B cards may require dual 60 Amp power feeds, depending on frame configuration.
- The BLMCAP GPL must be flashed on EPM-B based cards before the card can be initialized.

2.200 Equipment Identity Register (EIR) (Release 31.0)

This feature is intended to reduce the number of **GSM** mobile handset thefts by providing a mechanism that allows the network operators to prevent stolen or disallowed handsets from accessing the network. This control is done by using the International Mobile Equipment Identity (**IMEI**) provided during handset registration and comparing it against a set of lists provided by the network operator. There are three lists: Black, Gray and White. Mobile Stations (**MS**) on the white list are allowed access to the network. **MSs** on the black list are denied access to the network. **MS's** on the gray list are allowed on the network, but are logged.

This feature meets the mandate of European countries to provide **EIR** functionality by providing the network operators the ability to prevent stolen handsets from accessing their networks.

2.201 Error Message Reporting Enhancement (Release 21.0)

Before Release 21.0, the global title and gateway screening functions display a single error (unsolicited alarm message - **UAM**). This does not show all of the global title and gateway screening error messages that occur.

This feature allows more information about global title and gateway screening error messages to be reported to the user.

The number of global title error messages and gateway screening error messages displayed is increased to 5 messages/second/card. Each card can report up to 8 messages per second to the system. Any global title error messages and gateway screening error messages generated beyond the 8 messages/second/card rate are discarded, with the newest messages discarded first. Low priority messages are discarded when the transport buffer is full (8 total messages). High priority messages are discarded when the transport buffer is completely full with high priority messages.

2.202 Ethernet B Interface for IPGWx and IPLIMx (Release 28.1, IP7 Release 6.0)

Description

This feature activates the second Ethernet Interface (the B Interface) on the **SSEDCM** card types. This allows **IP** connection-oriented transports, such as **TALI** sockets and **IETF SCTP** associations, to utilize either of the card's Ethernet A or B Interfaces when forming a connection. This feature provides direct access to two separate **LANS**, effectively doubling the connectivity of each **SSEDCM** card.

As part of this feature's implementation, multiple static **IP** routes are permitted for **SSEDCM** card types. Each unique static route can be configured to use a different gateway router to reach remote destinations. This provides the capability to utilize more network paths for **IP** connection-oriented transports to access remote **IP** networks.

The addition of Static **IP** Routes enables **IP** connection-oriented transports to be accessible through gateways other than the default router. By providing access to a greater number of **IP** gateways, more destinations can be reached in a more efficient manner. Also, more time efficient **IP** connections can be utilized.

Doubling the connectivity to local networks and providing a more diversified access to remote networks greatly increases the flexibility of the **IP7** Secure Gateway and **EAGLE STP**. Enabling each **SSEDCM** card to directly access two Local Area Networks allows the arrangement of co-located **IP7 SG's/EAGLES** in ways to provide a higher level of redundancy.

Allowing the **SSEDCM** to be used as a multi-homing host also allows the **SCTP** protocol to utilize the protocol's multi-homing capability and provide support for local association endpoints that are multi-homed. **SCTP** multi-homed endpoints are endpoints that may use both Ethernet interface A and B for **SCTP** connectivity. This **SCTP** protocol capability provides for **SCTP** connections to be established that are more reliable and robust than **TCP** socket connections.

Hardware Requirements

This feature is intended for **SSEDCM** cards. The assignment of **IP7** connection-oriented transports to the Ethernet B Interface on **DCM** cards is not permitted.

Limitations

Limitations for the Ethernet B Interface for **IPGWx / IPLIMx** feature are listed below.

- Only one default router can be assigned per card.
- **SSEDCM** cards will act as follows:
 - uni-homing on the Ethernet A interface,
 - uni-homing on the Ethernet B interface, and
 - multi-homing on the Ethernet A and B interfaces.
- A finite number of static **IP** routes per card exists; the limit is 50 per card per **EAGLE**.
- There are per card and per system limits on the maximum number of static **IP** routes supported.

- a maximum of 64 static **IP** routes per **IPGWx / IPLIMx** card, and
- a maximum of 1024 static **IP** routes per system.
- No additional database validations will be performed on upgrade.
- No increased in load performance is provided.
- Static **IP** routes can lead to unreachable hosts.

2.203 Expanded Terminal Output Groups (Release 31.3)

The output groups currently defined by the **EAGLE** allow the messages generated by the system to be selectively displayed on the various terminals connected to the **EAGLE**. The expansion adds 12 new output groups and reassigns messages from existing groups to be used exclusively for controlling the output destination of all **UAMs** and **UIMs**. Upgrade automatically assigns messages to the correct groups.

The upgrade will automatically change existing groups to the new groups and additional output may be seen post upgrade depending on which groups are activated.

2.204 Extended Bus Interface (Release 20.0)

Every two card locations, except for card locations 9 and 10 in all shelves, and 17 and 18 in the control shelf (1117 and 1118), are connected together through the shelf backplane by an extended bus interface (**EBI**). The **EBI** is a local bus and not connected to the **IMT** bus. This allows every two card locations to communicate with each other without going over the **IMT** bus. The **MCAP** card and the **TDM** are connected to each other through the **EBI** to form the **MASP**. This also eliminates the 10 Mb/s ethernet **LANs** with their outboard **MAU** units that connected the **MCMs** and **PSMs** in the **EAGLE STP/1 MAS**.

2.205 Extended EPAP DN Block Capacity (EPAP 16.0)

The EPAP DN Block capacity is extended from 100,000 ranges to 200,000 ranges. A new table is added to support this capacity increase.

2.206 Extension Shelf Backplane (Release 23.0)

A new extension shelf backplane has been introduced in Release 23.0 with these changes:

- The extension shelf backplane now contains four -48VDC power and ground connections (**DB-26** connectors). Two of these connectors are labeled A1 and B1 and are connected to the fuse and alarm panel. The other two are labeled A2 and B2 and are connected to another power source, allowing the **EAGLE** to remain in service when replacing the fuse and alarm panel.
- The shelf address of the extension shelves has been expanded from four bits to six bits, increasing the number of addressable extension shelves from 15 to 64 and increasing the maximum number of addressable card slots from 250, or 500 signaling links, to a theoretical limit of 1018, or 2036 signaling links. The actual number of addressable card slots is limited by the system software and the hardware configuration of the **EAGLE**. In Release 23.0, the actual number of

addressable card slots is 378, or 756 signaling links, but is limited by the system software to 250 cards, or 500 signaling links.

- To enable the cards in the extension shelf to select one of two different types of **IPMX** cards that could be in the extension shelf, pin D53 of connector P9 transmits signal **ABMUXIN-** to pin D26 on connectors P1 to P8 and P10 to P17, and pin D53 of connector P26 transmits signal **BBMUXIN-** to pin D27 on connectors P18 to P25 and P27 to P34.

3

Features F - K

This chapter describes features starting with letters from F to K.

3.1 Fall-back to GTT after LNP MR Service (Release 43.0)

The Fall-back to GTT after LNP MR Service feature allows Global Title Translation (GTT) to be performed on MSUs after the MSUs are processed by LNP MR services. GTT is used to determine the alternative database node for optimal routing. The LIDB, CLASS, CNAM, ISVM, and WSMSC LNP MR services are supported.

3.1.1 Feature Control Requirements

The EGTT feature must be turned on before the Fall-back to GTT after LNP MR Service functionality can be provisioned.

3.1.2 Hardware Requirements

The Fall-back to GTT after LNP MR Service functionality requires an E5-SM4G or higher card.

3.2 False Link Congestion Management (Release 21.0)

It's possible that a problem on a signaling link can cause that signaling link to go into congestion, even though the traffic on the linkset is not high enough to cause congestion. For example, if a signaling link has a large number of retransmissions, the throughput of the signaling link could drop enough to cause congestion on that signaling link. To help prevent this from happening, the **EAGLE** starts the level 3 T31 timer whenever a signaling link goes into congestion. If the signaling link remains in the same congestion state until the level 3 T31 timer expires, the signaling link is removed from service. The signaling link becomes unaligned, and the alignment procedure is started.

The congestion level that starts the level 3 T31 timer can be set to either congestion level 1 or congestion level 2 using the `chg-stpopts` command with the `mtpt31ctl` parameter. This congestion level can be verified with the `rtrv-stpopts` command and is shown in the **MTPT31CTL** field. The level 3 T31 timer is started when the signaling link reaches this congestion level or a higher level. An increase in congestion level or abatement to a lower congestion level restarts the timer. When the congestion level goes below the congestion level configured in the `chg-stpopts` command, the level 3 T31 timer is stopped. If the level 3 T31 timer expires and the signaling link's congestion level has not changed, the signaling link is restarted.

For example, if the level 3 T31 timer is set at 60 seconds and a signaling link goes into congestion level 1, the level 3 T31 timer is started. If, after 45 seconds, the signaling link's congestion increases to level 2, the timer is restarted to 60 seconds. If the signaling link remains at congestion level 2 for 60 seconds, the signaling link is taken out of service and it becomes unaligned. Then the alignment procedure is started, and the **EAGLE** attempts to

realign the signaling link. The level 3 T31 timer can only be assigned to **ANSI SS7** linksets and signaling links.

3.3 EAGLE 5 ISS Fast Copy (Release 40.1)

The EAGLE Fast Copy (Fast Copy) feature uses a fast copy interface to the Integrated Message Feeder (**IMF**) to transport monitored SIGTRAN data while bypassing the Inter-Module Transport (**IMT**) and network stack. This ability allows data from the SIGTRAN network to be monitored in real time without impacting the EAGLE 5 ISS IMT bus, thereby eliminating EAGLE 5 ISS overhead.

The existing STC interface is used to transport configuration and link event data. Fast Copy architecture uses two separate networks for STC monitoring and Fast Copy monitoring.

The Fast Copy feature runs on E5-ENET cards that are running the **ipsg** application. The Fast Copy mode is a system-wide option. If the mode is set to fast copy, then all cards that are capable of supporting Fast Copy will switch to Fast Copy Monitoring.



Note:

A card that can run the Fast Copy interface is referred to as an *FC-capable* card. After the Fast Copy feature is provisioned on an FC-capable card, the card is referred to as an *FC-enabled* card. Currently, E5-ENET cards running the **ipsg** application are the only supported FC-capable cards.

The E5-ENET physical interface supports two additional ports per card. These two additional ports are used as the Fast Copy interface. All Fast Copy operations are supported on both interfaces simultaneously.

3.3.1 Feature Control Requirements

The Fast Copy feature has the following feature control requirements.

- The E5IS feature bit must be turned on before the Fast Copy option or network parameters can be provisioned.
- The `chg-eisopts:eiscopy=on` command must be entered before the Fast Copy option can be provisioned.

3.3.2 Hardware Requirements

The Fast Copy feature has the following hardware requirements:

- FC-capable cards. Currently, the only supported FC-capable cards are E5-ENET cards running the **ipsg** application.
- The E5-ENET physical interface supports two additional ports per card via the same backplane connectors as the existing E5-ENET based IP links. Two new upper and lower port adapters (part numbers 830-1343-01 and 830-1343-02, respectively) are required to support the existing SSED CM cables and the new port connection for the “Fast Copy” port.

3.3.3 Limitations

When the Fast Copy option is enabled, all of the monitored connections that are hosted on FC-enabled cards are brought down in order to re-establish the session to perform Fast Copy.

3.4 Feature Control Mechanism (IP7 Release 3.0)

Feature Control provides a mechanism for restricting and monitoring controlled features.

DCM throughput is the only controlled feature for release 3.0. The default rate of transactions per second (**TPS**) on the system for release 3.0 is 200. As a customer's network needs exceed this threshold, ever higher **TPS** rates can be purchased and enabled in increments of 200 up to a **TPS** rate of 6000 (raw capacity).

Note that this feature is available only on **DCMs** running **IPGWx GPLs**.

3.5 File Complete Alarm after Completion of PDB Export (EPAP 16.0)

A File Complete alarm (*Export PDB to file completed successfully*) is generated after the PDB file export operation is finished.

3.6 File Transfer Utility (Release 20.0)

This feature provides the capability to upload generic updates and changes to the **EAGLE** via a data communications link. This is an objective stated in Bellcore's **TR-NWT-000082**, Issue 4, December 1992 publication.

The data communications link is accessed through a dial up modem using one of the **EAGLE's RS-232** serial I/O ports. This data link is a secured link with password protection. The capability is also provided to download data or a generic program loads from the **EAGLE** to a remote site, allowing operators to gather traffic measurement data in bulk or raw form. Tekelec's Technical Services department may also use this capability when troubleshooting site problems.

3.7 Flash Memory Management (Release 23.0)

This feature gives the user the ability to update the image of the **PROM** on the **LIMATM**, P/N 870-1293-xx, without physically replacing the **PROM**. The image of the **PROM** is shown in the **EAGLE** as a **GPL**, the **BPHCAP GPL**.

The **LIMATM** contains a **PROM** that can be written to by the system software. In previous releases, cards had to be removed from the **EAGLE** and the **PROM** physically removed from the cards to update the image of the **PROM**. With this feature, the **LIMATM** does not have to be removed from the **EAGLE** to update the image of the **PROM**. Other cards in the system must still be removed from the **EAGLE** to update the image of the **PROM**.

The **BPHCAP GPL** contains software used by the application processor and the **IMT** processor of the **LIMATM**. Because the **BPHCAP GPL** contains software for the **IMT** processor, the **IMT** Software Download feature, introduced in Release 21.1, is prevented from

downloading the **IMT GPL** to the **LIMATM**. The system software detects the presence of the **LIMATM**, and the **IMT** download is prevented.

The process of loading the **BPHCAP GPL** on the **EAGLE** is different from the loading of other **GPLs**.

1. To bring the **BPHCAP GPL** onto the **EAGLE**, insert the removable cartridge into the removable cartridge drive on the **MDAL** then copy the **BPHCAP GPL** from the removable cartridge to the fixed disk with the `chg-gpl` command.
2. Place the card that the **BPHCAP GPL** is being loaded onto out of service using the `rmv-card` command.
3. Start the **BPHCAP GPL** change by entering the `init-flash` command with the `code=trial` parameter. This loads the trial version of the **BPHCAP GPL** onto the specified card. When this command is successful, the card reboots and two minor alarms are generated. One alarm shows that the card is running an unapproved **GPL**, **UAM 0002**, and the other shows that the card is running an unactivated **BPHCAP GPL**, **UAM 0004**.
4. Place the card back into service with the `rst-card` command.
5. Activate the **BPHCAP GPL** on the card with the `act-flash` command. **UAM 0004** is cleared. **UAM 0002** is not cleared until all **LIM-ATMs** have been updated with the new **BPHCAP GPL**.
6. Repeat Steps 2 through 5 for other **LIMATMs** in the **EAGLE**.
7. Make the trial version of the **BPHCAP GPL** the approved version with the `act-gpl` command.

3.8 Flexible GTT Load-Sharing (Release 35.0)

Description

The Flexible GTT Load Sharing feature allows a PC or PC/SSN combination to be provisioned in multiple load-sharing relationships for post-GTT load sharing of intermediate and final GTT traffic.

Load sharing for intermediate GTT traffic requires the Intermediate GTT Load Sharing feature, which can run in conjunction with the Flexible GTT Load Sharing feature. Intermediate GTT load sharing is performed through the EAGLE 5 ISS MRN table, and the GTT destination is a PC. If both the Intermediate GTT Load Sharing and the Flexible GTT Load Sharing features are on, different load-sharing relationships can be defined between the same set of PCs, and different sets of destinations can contain the same PCs.

The Flexible GTT Load Sharing feature allows a PC to be part of more than one load-sharing group, with each PC defined by a different MRN set. An MRN set consists of a logical grouping of PCs that has been provisioned in the MRN table. An MRN set either has an ID consisting of a specific number or is used as the default MRN set, which contains multiple logical PC groups.

When the Intermediate GTT Load Sharing feature is enabled, all existing entries in the MRN table and all existing GTA translations in the GTT table with `RI=GT` are stored in default MRN sets. A user can provision additional MRN sets and associate GTT entries to the MRN sets.

Although the Flexible GTT Load Sharing feature allows a PC to be part of multiple MRN sets, there cannot be multiple instances of a single PC within the same MRN set or within the default MRN set.

Load sharing for final GTT traffic is performed through the EAGLE 5 ISS MAP table, and the GTT destination is a PC/SSN combination. If the Flexible GTT Load Sharing feature is on, different load-sharing relationships can be defined between the same set of PC/SSNs, and different sets of destinations can contain the same PC/SSN combinations.

Although the Flexible GTT Load Sharing feature allows a PC/SSN combination to be part of multiple MAP sets, there cannot be multiple instances of a single combination within the same MAP set or within the default MAP set.

Hardware Requirements

The Flexible GTT Load Sharing feature has the following hardware requirements:

- The SCCP application must run on a DSM card or higher.
- No SCCP application can be provisioned in the system if TSM cards are used.

Limitations

The Flexible GTT Load Sharing feature has the following limitations:

- MPS-based features cannot use the Flexible GTT Load Sharing feature.
- The `ent/chg-gtt/gta` commands do not support auto-creation of MAP entries.
- If the Flexible GTT Load Sharing, Intermediate GTT Load Sharing, and SCCP Service Reroute Capability features are enabled, the number of entries that can be provisioned in the MRN table is reduced by the number of entries in the SCCP-SERV table. If the Flexible GTT Load Sharing and Intermediate GTT Load Sharing features are enabled, the maximum number of entries that can be provisioned in the MRN table is 6000. If the Service Reroute Capability feature is also enabled, the maximum number of entries that can be provisioned in the MRN table is 6000 - the number of entries in the SCCP-SERV table.

3.9 Flexible Intermediate GTT Load-Sharing (Release 34.2)

Description

The Flexible Intermediate **Global Title Translation (GTT)** Load-Sharing feature enables the user to define multiple relationships among groups of destination point codes in the **Mated Relay Node (MRN)** table. The relationship that is used in a particular translation is based on the Global Title Address digits used for translation.

When the Flexible Intermediate **GTT** Load-Sharing feature is turned on, it introduces the **MRN Set ID** into the **MRN** table, which localizes the scope of a point code to a group. An **MRN Set ID** uniquely identifies each such group. A point code can now exist in multiple such groups, but is expected to be unique within a group. The feature also introduces **MRN Set ID** as a result of a Global Title (**GT**) translation. Following **GT** translation, the **MRN Set ID** and the post-translation point code are used as an entry point into the **MRN** table. The **PC** and its group of alternate point codes, all of which have same **MRN Set ID**, will be accessed together along with their respective relative cost (**RC**) to identify the most cost effective way of load-sharing.

The **MRN** table contains point codes that are associated in groups with the same **MRN Set ID**. The groups provide alternate routing options in the event that the desired point code becomes unavailable.

The Flexible Intermediate **GTT** Load-Sharing feature provides a more flexible way of assigning Load-Sharing rules amongst Global Title Addresses (**GTAs**). For example, in the following figure,

GTA=9194605500 could translate to **PC=1-1-1** and have a load-sharing relationship with **PC=2-2-2**.

GTA=9194611000 could also translate to **PC=1-1-1**, but not have a load-sharing relationship with any other **PC**.

GTA=9193881416 could also translate to **PC=1-1-1**, and have a load-sharing relationship with **PC=2-2-2** and **PC=3-3-3**.

In the scenario depicted in the following figure, the Flexible Intermediate **GTT** Load-Sharing feature routes the post-**GTT** traffic as follows:

- **GTA=9194605500** is divided equally between **PCs 1-1-1** and **2-2-2**,
- **GTA=9194611000** is always sent to **PC 1-1-1**, and
- **GTA=9193881416** is divided equally between **PCs 1-1-1**, **2-2-2**, and **3-3-3**.

GTA entry 9193881100 would also translate to **PC 1-1-1**, but **PC 1-1-1**, **PC 4-4-4**, **PC 5-5-5** and **PC 6-6-6** are working in combined mode i.e. **PC 1-1-1** and **PC 4-4-4** are working in load share mode and **PC 5-5-5** and **PC 6-6-6** are in dominant mode. Therefore post-**GTT** traffic for **GTA** entry 9193881100 is equally divided between **PC 1-1-1** and **PC 4-4-4**.

Figure 3-1 Organization of PCs in Flexible Intermediate GTT Load-Sharing Feature

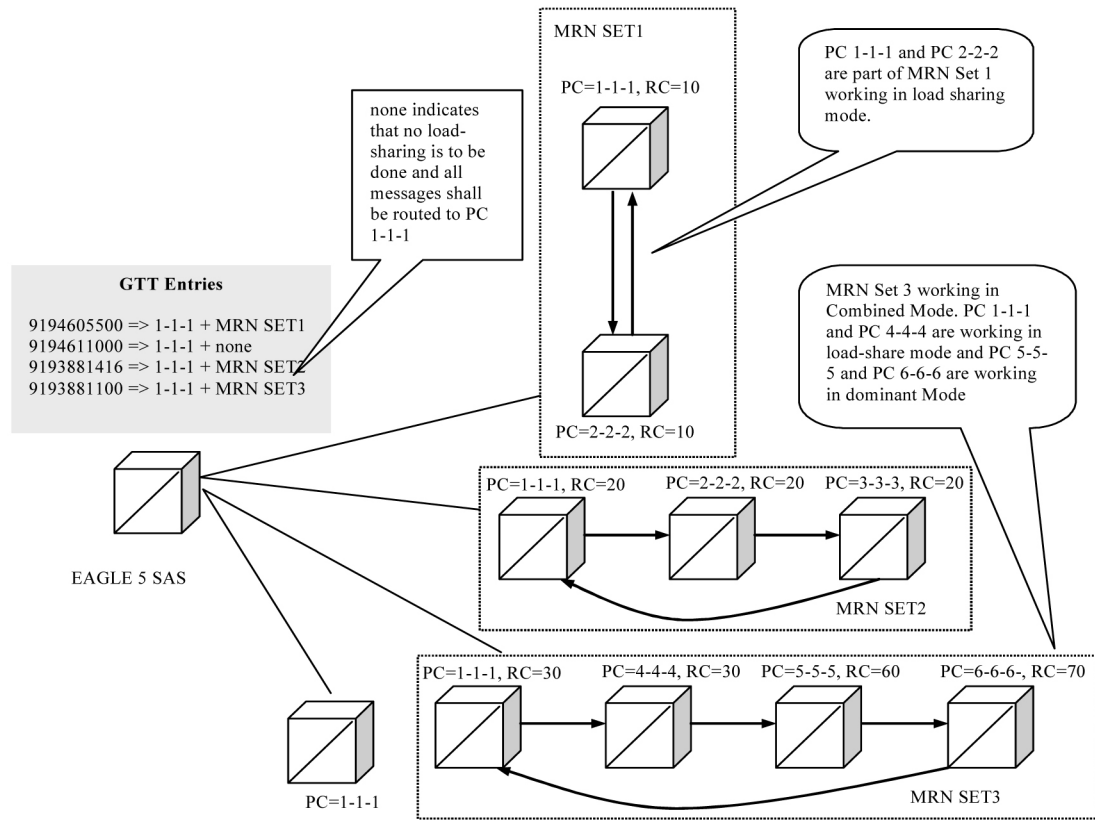

Flexible Intermediate **GTT** Load-Sharing provides the ability to load share between multiple nodes after **GT** translations when the outgoing (post **GTT**) message is route-on-**GT**. The resulting **PC** value of **GTT** is looked up in the **MRN** table. If the translated **PC** is not found in the **MRN** table, the message is routed as per existing **EAGLE 5 SAS** functionality.

The destination point code stored in the **MSU** will be changed when a load-sharing **PC** is selected.

The Flexible Intermediate **GTT** Load-Sharing feature provides the ability to define multiple load-sharing groups in the **MRN** table where a **PC** can be shared among different load-sharing sets.

Default MRN Set

Once the Flexible Intermediate **GTT** Load-Sharing feature is enabled, any existing entries in the **MRN** Table become part of a **default MRN Set**. In addition, all existing **GTA** translations in the **GTT** Table that have a routing indicator (ri) equal to **GT** are assigned a default **MRN Set**.

Flexible Intermediate **GTT** Load-Sharing provides flexible load-sharing for translations defined in **GTT** Tables but not **MPS**-based tables. Since **MPS**-based features do not support an **MRN Set Id**, to be able to take advantage of the Flexible **GTT** Load-Sharing functionality, **MPS**-based features need to be modified. Until all **MPS**-based features are converted and able to use Flexible **GTT** Load-Sharing, a default **MRN Set** is used to provide the necessary support.

The default **MRN Set** consists of multiple load sharing groups of **PCs** that allow both **GTT** features and **MPS**-based features to run in parallel. **MPS**-based features are limited to using **ONLY** the default **MRN Set**. **GTT** features can be provisioned to use the default **MRN Set** as well. To operate on entries in the default **MRN Set**, the user must specify default as the value of the **MRN Set** in the **GTA** translation.

The default **MRN Set** consists of multiple load-sharing groups of **PCs** as shown in the following figure.

Figure 3-2 Concept of Default MRN Set

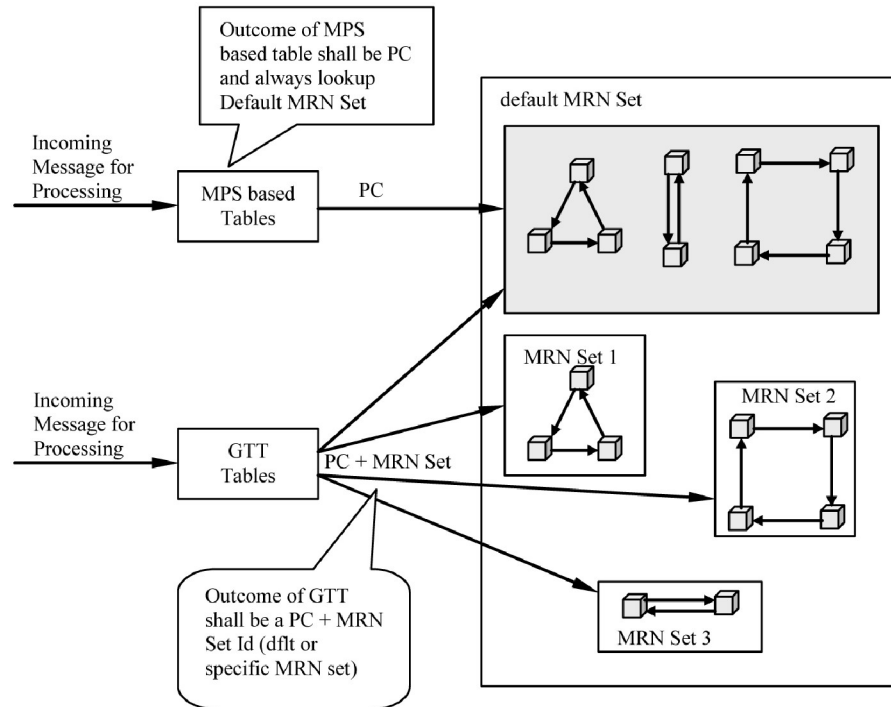

None MRN Set

As mentioned earlier, once the Flexible Intermediate **GTT** Load-Sharing feature is enabled, any existing entries in the **MRN** Table become part of a default **MRN Set**. All existing **GTA** translations in the **GTT** Table that have a routing indicator equal to **GT** ($ri=gt$) are assigned a default **MRN Set**. This assignment to a default **MRN Set** in the **GTA** translation is irrespective to whether the translated **PC** exists in any **MRN Set**. If no load sharing is desired, the user must manually change the **GTA** translation to **MRN Set** equal to None. (`mrnset=none`).

Load-Sharing Modes

There are three possible load-sharing modes in an **MRN Set**.

- Dominant
- Load-Share
- Combined Dominant/Load-Share

The mode that gets applied to an **MRN** Load-Sharing Set is determined by the relative cost of the **PCs**.

Dominant Mode

An **MRN** Load-Sharing Set is in Dominant Mode if each **PC** in the group has a unique relative cost as shown in the following table. The **PC** selected first (preferred) is the **PC** with the lowest cost that is available. If the preferred **PC** is not available, then the **PC** with the next lowest relative cost that is available is selected

Table 3-1 MRN Table (MRN Set in Dominant Mode)

MRN Set ID	PC	Relative Cost	Next Alternate Point Code
1	1-1-3	15	1-1-1
1	1-1-1	20	1-1-2
1	1-1-2	30	1-1-3

Global Title to the Lowest Cost PC

If an **MSU** comes in with **TT** =10, **GTA**= 9194605212, then as shown in the following table:

- If **PC** 1-1-3 is available, the **MSU** is routed to 1-1-3, which is the preferred **PC**.
- If **PC** 1-1-3 is not available but **PC** 1-1-1 is available, the **MSU** is routed to **PC** 1-1-1, which is the next preferred **PC**.
- If **PC** 1-1-3 and **PC** 1-1-1 are not available but **PC** 1-1-2 is available, the **MSU** is routed to **PC** 1-1-2, which is next preferred **PC**.
- If all **PCs** are unavailable in the **MRN** set, the message are dropped. .

Table 3-2 GT Translation Table

Translation Type	GTA	PC	MRN Set Id
10	9194605000 to 9194605499	1-1-3	1
10	9194605500 to 9194605599	1-1-1	1
10	9194605600 to 9194605799	1-1-3	2
10	9194605800 to 9194606000	1-1-1	3

Global Title to a Higher Cost PC

It is possible that the result of a **GT** translation is not the same as the lowest cost **PC**. This **PC** is still the preferred **PC** and will be selected if it is available. If the preferred **PC** is not available then, the available **PC** in the list of alternate **PCs** with the next higher relative cost is selected for routing.

If an **MSU** comes in with **TT**=10, **GTA**=9194605555 then as shown in the following table:

- If **PC** 1-1-1 is available, the **MSU** is routed to **PC** 1-1-1, which is the preferred **PC** for this translation.
- If **PC** 1-1-1 is unavailable but 1-1-2 is available, the **MSU** is routed to **PC** 1-1-2, which is the next preferred **PC**.

- If **PCs** 1-1-1 and 1-1-2 are not available but **PC** 1-1-3 is available, the **MSU** is routed to **PC** 1-1-3, which is the next preferred **PC**.
- If none of the **PCs** are available, the message is dropped.

Load-Share Mode

An **MRN** Load-Sharing Set is in Load-Share Mode if each **PC** in the group has the same relative cost. The EAGLE 5 ISS evenly distributes the translated **MSUs** to each of the **PCs** listed in the following table.

- If one or more of the **PCs** are not available, the EAGLE 5 ISS evenly distributes the **MSUs** to the remaining **PCs** in the group that are available.
- If none of the **PCs** in the group are available, the message is dropped

Table 3-3 MRN Table (MRN Set in Load-Share Mode)

MRN Set ID	PC	Relative Cost	Next Alternate Point Code
2	1-1-3	10	2-2-1
2	2-2-1	10	2-2-2
2	2-2-2	10	1-1-3

Combined Dominant/Load-Share Mode

A group of **PCs** is in Combined Load-Share/Dominant Mode when

- at least two of the **PCs** have the same relative cost and,
- another **PC**, or group of **PCs**, in the **MRN Set** has a different relative cost.

Table 3-4 MRN Table (MRN Set in Combined Load-Share/Dominant Mode)

MRN Set	PC	Relative Cost	Next Alternate Point Code
3	1-1-1	10	3-3-1
3	3-3-1	10	3-3-2
3	3-3-2	20	3-3-3
3	3-3-3	20	1-1-1

If an **MSU** comes in with **TT** 10, **GTA** 9194605999 then as shown in the following table:

If both **PC** 1-1-1 and **PC** 3-3-1 are available, the EAGLE 5 ISS will evenly distribute **MSUs** for **TT**=10 and **GTA**=9194605999 to **PC** 1-1-1 and **PC** 3-3-1.

If **PC** 1-1-1 is not available, the EAGLE 5 ISS will send all **MSUs** to **PC** 3-3-1.

If both **PC** 1-1-1 and **PC** 3-3-1 are not available, the EAGLE 5 ISS will evenly distribute the **MSUs** to **PC** 3-3-2 and **PC** 3-3-3.

If all **PCs** in this **MRN Set** are unavailable, the message is dropped.

Handling of SCCP Class 1 Messages

If the In-Sequence Class 1 **SCCP** option is **ON**, **MSUs** are routed to the **PC** that results from the **GTT** regardless of the mode of the **MRN Set**, and the sequence of the **MSUs** is maintained. If that **PC** is down, then the **MSUs** are routed to the next preferred node in the **MRN Set**.

If the In-Sequence Class 1 **SCCP** option **OFF**, the EAGLE 5 ISS load-shares the **MSUs** depending on the mode of the **MRN Set**, and the sequence of the **MSUs** is not maintained.

Activation

The Flexible **GTT** Load-Sharing feature requires activation via a feature access key (**FAK**). This feature key applies to all flexible **GTT** loading functionality. However, Flexible Intermediate **GTT** Load-Sharing is a separate feature within the EAGLE 5 ISS. To access the functionality of this feature, both the Flexible **GTT** Load-Sharing **FAK** and the Intermediate **GTT** Load-Sharing **FAK** must be on.



Note:

Currently flexible load-sharing functionality only applies to **GTT** tables. **MPS**-based features are **NOT** be able to take advantage flexible load-sharing.

Hardware Requirements

No new hardware is required for this feature.

The Flexible **GTT** Load-Sharing Feature requires a **DSM** card running the **VSCCP** application.

The Flexible **GTT** Load-Sharing Feature is not supported on **TSM** cards running the **SCCP** application.

Limitations

The **MRN** table has a maximum of 6000 **MRN** entries.

The Flexible Intermediate **GTT** Load-Sharing feature is not supported on **TSM** cards running the **SCCP** application.

Flexible **GTT** Load-Sharing feature does not support **SEAS**.

3.10 Flexible Link set Optional Based Routing (Release 41.0)

The Flexible Link set Optional Based Routing (**FLOBR**) feature allows **GTT** routing to be based on the incoming linkset. Messages that encounter **GTT** are routed based on the incoming linkset of the original **MSU**. **MSUs** that are generated by the EAGLE 5 ISS use a separate set of **GTT** selector entries.

The **FLOBR** feature also allows full customization of the **GTT** routing hierarchy. If flexible routing is used, then a predetermined routing hierarchy is not necessary. The **GTT** routing translation can link to any **GTT** set as long as the **GTT** set has a different set type.

The capacity of the **GTT** selector table is increased to support 100,000 **GTT** selectors.

3.10.1 Feature Control Requirements

Feature control requirements for the FLOBR feature include:

- FAK for part number 893-0277-01
- The Enhanced GTT feature must be turned on before the FLOBR feature can be enabled.
- A temporary FAK cannot be used to turn on the feature.
- After the feature is turned on, it cannot be turned off.

3.10.2 Hardware Requirements

The FLOBR feature requires an E5-SM4G or higher card.

3.11 Flexible Point Code Formatting (Release 26.0)

Description

The Flexible **Point Code** Formatting feature provides the customization and flexibility of the **EAGLE** point code provisioning system to meet the needs of **ITU-N** customers who required a specific **ITU-N** point code format. The one commonality of the all **ITU-N** point codes is that the point code is stored in a 4-byte field in our database (14 bits used for **ITU** point codes). This value does not change, no matter how it is displayed or input on the **EAGLE**.

For example, suppose the **EAGLE** is deployed to 5 different regions for **ITU-N** customers in Europe. Each region has its own way of viewing point codes in its private network. One region may wish to distribute its point codes in a format such as A-B, where A ranges from 1 to 1024, and B ranges from 1 to 16. Other regions may wish to use an A-B-C-D point code format. The following table provides examples of how these point codes might be used in different regions.

Table 3-5 Sample ITU-N Point Codes

Region 1	Region 2	Region 3	Region 4	Region 5
1000-1	5-5-5-1	3-8-3	4000	1000-1-1
1000-5	3-1-1-0	1-7-1	16000	1000-0-1
1000-6	5-2-1-3	1-100-1	12000	800-1-0

Upgrade Considerations

All **EAGLES** that are upgraded to software that includes the Flexible **ITU-N Point Code** Feature must have the **NPCFMTI** parameter in the **STPOPTS** table set to a system default of 14-0-0-0.

Limitations

It is important to note that this feature does not provide the ability to support point codes that are not 14 (**ITU**) or 24 (**ANSI**) bits in length, and has no impact on **EAGLE SS7** message processing. Also, it does not apply to gateway screening commands

and output, due to the way that **GWS** was originally designed to take into account the point code format.

3.12 FLOBR Enhancements (Release 42.0)

The Flexible Linkset Optional Based Routing (FLOBR) feature is enhanced to provide the following functionality:

- **Fall-back to GTT after EPAP-based Relay Services**
Global Title Translation (GTT) can be performed on an **MSU** that is relayed to another destination based on routing data obtained from the EPAP database/PPSOPTS table by an EPAP-based service. GTT for Service Related MSUs is performed on a service selector basis. Each supported service selector can be configured to indicate whether **GTT** is required after service execution is complete. The MNP, GFLEX, GPORT, SMSMR, IDPR, INPMR, and TTR service selectors are supported.
- **GTT/TT Commands allowed with EGTT**
The `ent/dlt/rtrv-tt` and `ent/chg/dlt/rtrv-gtt` commands are supported for GTT simple entries (entries that have not been modified by enhanced GTT processes) independently of the enabled GTT features.
- **CdPA SSN for GTT Routing**
GTT routing can be performed based on Called Party (CdPA) Subsystem Number (SSN) translations when the FLOBR feature is turned on.
- **DPC for GTT Routing**
The MTP Destination Point Code (DPC) can be considered as part of the routing criteria for GTT Routing.
- **Use of the same GTT set types in a Translation Search**
When performing a translation using FLOBR processing, lookup can occur in the same GTT set type up to 7 times during a search. The same set name cannot be repeated in a single GTT search.
- **Feature independence of the TST-MSG tool**
The TST-MSG tool can be used when any GTT feature is turned on.

3.12.1 Feature Control Requirements

- The GTT feature bit must be turned on before the Fall-back GTT functionality can be provisioned, the GTT commands can be used with EGTT, and the TST-MSG tool can be used with any GTT feature.
- The FLOBR feature (Part Number 893-0277-01) must be turned on before the **DPC** for GTT Routing, **CdPA SSN** for GTT Routing, or Use of the Same GTT Set Types in a Translation Search functionality can be provisioned.

3.12.2 Hardware Requirements

E5-SM4G cards must be provisioned before any of enhancements that involve the FLOBR feature can be provisioned. Use of the Test Tool and allowing the GTT/TT commands with the EGTT feature does not require **E5-SM4G cards**.

3.13 Force Change of an Assigned Password at First Login (Release 21.0)

When a password is assigned to a user by the system administrator with either the `ent-user` or `chg-user` commands (the `pid=yes` parameter must be specified with the `chg-user` command to change the user's password), that user is required to change the password when they first login to the **EAGLE**. If the user does not change the password, the login session is rejected.

As part of the password verification process, a check is performed to make sure that the user has changed the password and did not re-enter the current password as the new password.

3.14 FTP Retrieve and Replace (Release 29.0) (IP⁷ Release 7.0)

Description

Note:

The **FTP** Retrieve and Replace feature provides configuration and data transfer support on the **EAGLE** for the **FTP**-based Table Retrieve Application (**FTRA**), which resides on a customer-provided, Windows-based **PC** or Unix Workstation. **FTRA** will be available separately. In order to use **FTRA**, the **IP** User Interface: Telnet Support feature (**IP UI**) must be enabled. When the **IP UI** feature is enabled in Release 29.0, the functions provided by the **FTP** Retrieve and Replace feature become available for communication between the **EAGLE** and **FTRA**.

The **FTP** Retrieve and Replace feature adds a new and expanded retrieve and replace capability to the **IP** User Interface Telnet feature.

This feature utilizes:

1. **GPSM-II** card as the hardware platform for **OAM**.
2. **IPSM** card as the hardware platform for the **IPS GPL**.
3. **FTP**-based Table Retrieve Application (**FTRA**) software running on a Unix or Windows-based **PC** platform connected to the **IPSM** card.

The **FTP** Retrieve and Replace Feature provides the following new capabilities:

- Enhanced retrieve capabilities of **EAGLE** table data, whereby the application will retrieve table data transparently upon request by the user, and later will convert, on demand, to a comma separated variable (.csv) file.
- Enhanced input capabilities of **EAGLE** table data, supporting input of script files containing scripts created by the user. The transfer of data to the **EAGLE** is transparent to the user.

- A much faster and more reliable retrieval and input capability.
- Validating data prior to input and identifying the data at issue.

The **FTP Retrieve and Replace** feature uses **FTP** commands to transfer relevant parts of the **EAGLE STP OA&M** database to a Unix or Windows-based **PC**, where a new Tekelec-developed Java-based application is running. The application provides features to input changes to table data.

The **IPS GPL** is memory-mapped such that the **FTP** area can handle the largest database file on the **OA&M**. The following figure illustrates the feature in relation to the system and customer's network.

Figure 3-3 FTP Retrieve and Replace

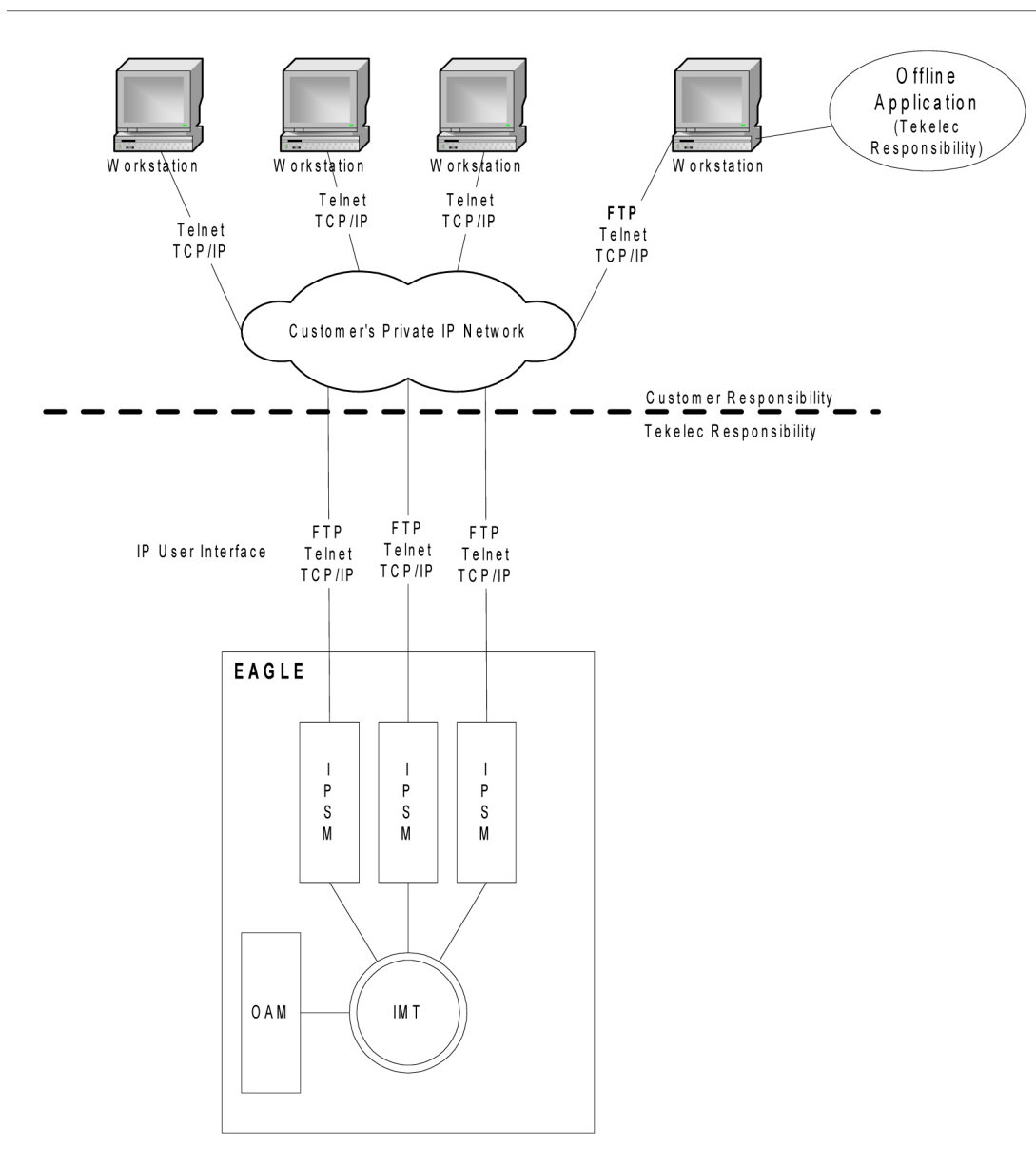

Hardware Requirements

This feature requires **IPSM (GPSM-II-based)** hardware with at least **1 GB of RAM** (i.e., **DSM 1GB** with the **IPS GPL [IPSM]**).

Caution:

Never install or initialize **MCAP** cards in **MASP** slots 1113 and 1115 after features that require **GPSM-II** cards are provisioned. Attempting to initialize **MCAP** cards with **GPSM-II** features provisioned will cause a system outage. Before replacing an existing **GPSM-II** card in a **MASP** slot (1113 and 1115) contact Tekelec Customer Service.

The application requires a **UNIX** workstation equipped with the following:

- Operating System - Solaris 7
- Processor speed - 500 **MHz**
- **RAM** - Minimum 512 **MB**
- Disk Space - Minimum 10 **GB**
- **CD-ROM** drive
- 10/100BaseT Ethernet connection to the **LAN**
- Static **IP** addressing
- Java Runtime Environment (**JRE**) 1.4.0 or later

The application requires a Windows **PC** workstation equipped with the following:

- Operating System - Windows 98 or later with Win32 **API**
- Processor speed - Pentium **III**, 750 **MHz** or faster
- **RAM** - Minimum 128 **MB**
- Disk Space - Minimum 500 **MB** free + 500 **MB** free per **STP**
- **CD-ROM** drive
- 10/100BaseT Ethernet connection to the **LAN**
- Static **IP** addressing
- Java Runtime Environment (**JRE**) 1.4.0 or later

3.15 FTRA 2.1 Compatibility with EAGLE 31.3 (Release 31.3)

The **FTRA** Release 2.1 provides **FTRA** compatibility with **EAGLE** 31.3. There are no new features or functionality in Release 2.1.

3.16 FTRA 2.2 Compatibility with EAGLE 31.6 (Release 31.6)

The **FTRA** Release 2.2 provides **FTRA** compatibility with **EAGLE** 31.6. The following changes have been made in **FTRA** 2.2 to support features new to Release 31.6:

- **ASM** Obsolescence - Data field of card type "**ASM**" changed to "**TSM**" for rtrv-card.
- **IPGWx TPS** Control and System-wide **IPGWx TPS**ñ New data fields **MATELSN**, **IPTPS**, **LSUSEALM**, **SLKUSEALM** added in rtrv-ls.
- Support **G-Flex** at 1700 **TPS** per **DMS** ñ New data field **ANSIGFLEX** added in rtrv-stpopts.
- **TDM** Global Timing Interface - New data fields **HSCLKSRC** and **HSCLKLL** added to support global timing interface in rtrv-stpopts.

3.17 FTRA Dependencies on EAGLE (Release 46.0)

The FTRA Dependencies on EAGLE feature removes all the FTRA dependencies on EAGLE, such as validation of `rtrv-gp1` in FTRA and generation of `stp.csv` by FTRA.

3.18 Gateway Screening Stop Action - De-encapsulate (Release 46.0)

The Gateway Screening Stop Action - De-encapsulate feature adds the capability to de-encapsulate a re-directed message from a remote EAGLE and provide all of the features and functionality to the encapsulated MSU as if the MSU were received without any SCCP encapsulation.

3.19 Gateway Screening Stop Action - Duplicate and Route (Release 46.0)

The Gateway Screening Stop Action - Duplicate and Route feature allows users to duplicate and forward ISUP messages selectively to another monitoring system where analysis can be performed to identify potential spam or robo-call scenarios. The Gateway Screening Stop Action - Duplicate and Route feature provides this capability of selective forwarding of MSU's to another network element.

3.20 Gateway Threshold Exceeded Notification (Release 22.0)

A notification message is produced to alert the user that excessive traffic is occurring on a gateway linkset or an excessive number of **MSUs** are being discarded on a gateway linkset. When either of these conditions occur, new **UIMs** are sent to the **EAGLE** terminals.

UIM 1154 - Gateway Arrival Threshold Exceeded - **MSU** reception threshold exceeded

```
RLGHNCXA03W 97-06-07 16:28:08 EST Rel 22.0.0  
0018.1154     SYSTEM          INFO MSU reception threshold exceeded
```

```
LSN=A1234567 REJ=199      RECV=5200   INTRVL=05
Report Date: 97-06-07   Time: 16:27:19
```

UIM 1155 - Gateway Discard Threshold Exceeded - MSU discard threshold exceeded

```
RLGHNCXA03W 97-06-07 16:28:08 EST Rel 22.0.0
0018.1155     SYSTEM      INFO MSU discard threshold exceeded
LSN=A1234567 REJ=199      RECV=5200   INTRVL=05
Report Date: 97-06-07   Time: 16:27:19
```

The message **REPT-GTWYACT** is sent to the **SEAS** interface when these conditions occur.

The term excessive is defined by two values.

- The number of **MSUs** discarded on the gateway linkset.
- The number of **MSUs** received on the gateway linkset.

These values measured over a user configurable period of time. If either of these values are exceeded within the specified period of time, then this notification occurs.

The threshold at which these **UIMs** are generated can be configured by the user on the **EAGLE** terminal with the `set-gtwy-acthresh` command.

Parameters

The `set-gtwy-acthresh` command uses these parameters.

:lsn = the name of the link set

:rej = the number of **MSUs** discarded on the gateway linkset threshold. The values for this parameter range from 0 to 999999

:recv = the number of **MSUs** received on the gateway linkset threshold. The values for this parameter range from 0 to 999999

:intrvl = the time interval, in minutes, during which the counts for the `rej` and `recv` parameters are made. The values for this parameter are 5,10,15, 20, and 30.

The current values for these thresholds can be displayed on the **EAGLE** terminal with the `rtrv-gtwy-acthresh` command. The following is an example of the `rtrv-gtwy-acthresh` command output.

Output Example

```
RLGHNCXA03W 97-06-07 08:50:12 EST Rel 22.0.0
LSN          REJ          RECV          INTRVL
WY644368    10           1000          10
WY234456    25           2000          20
LN123445    0            0             0
LN123556    25           2500          30
OP239900    0            0             0
```

These thresholds can also be configured on the **SEAS** interface with the **SET-GTWY-ACTHRESH** command function and displayed on the **SEAS** interface with the **RTRV-GTWY-ACTHRESH** command function.

The counts for the number of **MSUs** discarded and received on the gateway linkset are collected in the 5 minute measurement collection. These counts do not appear on any measurement reports, but are collected to support this feature. These counts track the two values that need to be monitored.

This feature no longer allows the 5 minute measurement collection to be stopped with the **EAGLE's** `chg-meas:collect=off` command. The 5-minute measurement collection still occurs, but no values are written to disk and no reports are produced.

3.21 General Purpose Service Module-II (GPSM-II) for MCAP Slot (Release 28.0)

Description

The Enhanced **MCAP**, otherwise known as the **GPSM-II (General Purpose Service Module, P/N 850-0622-01)** for **MCAP** Slot, is designed to provide better **OAM** task performance.

Future applications and table expansions will require increased performance across the **IMT** bus interface, both to and from the **Maintenance and Administration Subsystem (MAS)**. To help meet this need, the **GPSM-II** card incorporates a **DCM** design for the **OAM** functionality on the **EAGLE**.

GPSM-II is required for supporting the **EAGLE** Support for **Integrated Sentinel** feature via the Time Slot Counter (**TSC**) Synchronization feature.

Refer to the **NSD Hardware Manual** for the current hardware description.

New Hardware Required

The **GPSM-II** feature requires the new **GPSM-II (OAM)** card described above); no additional hardware is required.

Caution:

Never install or initialize **MCAP** cards in **MASP** slots 1113 and 1115 after features that require **GPSM-II** cards are provisioned. Attempting to initialize **MCAP** cards with **GPSM-II** features provisioned will cause a system outage. Before replacing an existing **GPSM-II** card in a **MASP** slot (1113 and 1115) contact Tekelec Customer Service.

The **TSC** Synchronization feature requires the new **GPSM-II EAGLE®** hardware equipped with the new **TSC** Synchronization hardware to support it. Time Slot Synchronization is an existing option for the **EAGLE** that allows all cards in the system containing a Time Slot Counter to synchronize with each another. The ability to have synchronized timing between cards is useful in applications such as system-wide message time stamping.

Upgrade Considerations

The **GPSM-II** feature allows the existing **OAM** functionality to operate on a **GPSM** card or **MCAP** card. In addition, the **EAGLE** will also support inserting an **MCAP** or **GPSM** card in the control shelf as an **OAM** card, even if the **OAM** card that is already inserted does not match the **OAM** card that is being inserted. This functionality is needed to support upgrade where the hardware is in transition. It is assumed that an **EAGLE** with an **MCAP** and a **GPSM** in **OAM** card slots 1113 and 1115 is a transitional state.

Consequently, software modification of the one-command upgrade function is necessary to support some requirements. Upgrade command support for the inhibiting of the standby **OAM** and upgrade of the board Flash memory is required.

3.22 G-Flex C7 Relay (Release 26.2)

Description

G-Flex optimizes the use of subscriber numbers and number ranges by providing a logical link between any **MSISDN/MIN/MDN** and any **IMSI**, as well as between any subscriber number and any **HLR**. This feature allows subscribers to easily be moved from one **HLR** to another.

Note:

This feature applies to any **GSM** or **IS-41**, **ITU**, or **ANSI** mobile network. In the following text, the term **DN** is used to indicate **MSISDN** numbers, **MINs**, or **MDNs**. Also, the term subscriber number is used to indicate **DN** and/or **IMSI**.

It also allows each **HLR** to be filled to 100% of its capacity by allowing subscriber number ranges to be split over different **HLRs**, and individual **DNs/IMSIs** to be assigned to any **HLR**. Another benefit is that subscriber number routing data is not required to be maintained in all **MSCs** in the network.

The initial version of **G-Flex**, as defined in this document, applies to routing to **HLRs** only. In the future, **G-Flex** may be expanded to include routing to other intelligent devices, such as **SCPs** (Service Control Points) and **VMSCs** (Voice Mail Service Centers), depending upon market needs.

G-Flex is optional on the **EAGLESTP**, and can be turned on (but not turned off) via a feature bit. **G-Flex** and North American **LNP** are mutually exclusive on an **EAGLE** node.

Refer to the Features Manual - **G-Flex** for the current information on this feature.

Upgrade Considerations

EAGLE Database

The **EAGLE** upgrade process is responsible for copying new **TDM** resident **G-Flex** tables from the upgrade removable cartridge to the newly formatted fixed disks. The **G-Flex** feature bit should not be turned on prior to or during an upgrade of an existing **EAGLESTP**.

EAGLE STP Audit

The **EAGLESTP** audit is designed to recognize when it is in upgrade mode, and will not attempt to do any activity that requires access to new **G-Flex** tables, since they will not be present until the upgrade has completed.

In order to convey **G-Flex** audit-detected errors to the active **OAM**, space in the common maintenance block header must be identified. In order to prevent false alarms during the upgrade, the revision level of the maintenance block has been redefined. Existing code that examines maintenance blocks will not interpret them if the system is in upgrade mode and the revision level in the received maintenance block is not at the expected value.

EAGLE Maintenance

During upgrade, the `rept-stat-epap` command output may not reflect the current state of the **GSM** system.

Hardware Requirements

This feature requires the **MPS** Hardware System.

Limitations

1. An E.214 number received by the **G-Flex**™ C7 Relay must first be converted to an E.212 number before searching the **G-Flex** database. If the original E.212 number was truncated to form the E.214 number, the full original E.212 number cannot be recovered, and **G-Flex**™ will not work properly.
2. No overload controls are required above and beyond existing **EAGLE** lower level mechanisms (e.g. for **MTP** congestion, etc.).
3. This initial version of the **G-Flex**™ C7 Relay only supports routing of messages to a single network node for a particular subscriber. For example, an individual subscriber cannot have some messages routed to his **HLR**, and other messages routed to a separate Authentication Center (AuC). In this example, if the AuC is co-located with the **HLR**, then this version of **G-Flex**™ will work. The **G-Flex**™ design allows for expansion to include routing to multiple network elements (corresponding to multiple services) for the same subscriber.
4. Messages routed by **G-Flex**™ cannot undergo **ANSI-ITU** conversion.

3.23 G-Flex MAP Layer Routing (Release 38.0)

The G-Flex MAP Layer Routing (MLR) feature allows subscriber digits to be obtained from either the SCCP layer or the MAP layer of a message during G-Flex database lookup. This ability resolves the issue of truncation of digits by the mobile switching center (**MSC**) that may occur in the SCCP layer.

This feature applies to GSM MAP Update_Location, GSM MAP Send_Authentication_Information (**SAI**), and GSM Send_Parameters messages. CdPA digits from the SCCP layer are used to route all other MAP messages.

Note:

The feature supports Send_Parameters messages only if the message contains the IMSI parameter.

As part of this feature, the G-Flex feature is converted from a feature bit to a FAK and part number.

3.23.1 Feature Control Requirements

The G-Flex MAP Layer Routing feature has the following feature control requirements:

- The G-Flex feature must be enabled and turned on (FAK for part number 893-0219-01) before the G-Flex MLR feature can be enabled.
- The G-Flex MLR feature requires a FAK for part number 893-0217-01
- If the **ansigflex** option in `chg-stpopts` command is turned on, then the feature cannot be enabled.
- A temporary FAK cannot be used to enable the G-Flex or the G-Flex MLR features.
- If the G-Flex feature is turned on with the feature bit before upgrade occurs, then the feature is automatically enabled and turned on with the FAK after upgrade.
- The G-Flex and G-Flex MLR features cannot be turned off after being turned on.

3.23.2 Hardware Requirements

There are no additional hardware requirements for this feature.

3.23.3 Limitations

ANSI G-Flex traffic at 1700 TPS per Service Module card and 5000 or 6800 TPS per E5-SM4G card are not supported by the G-Flex MLR feature. ANSI traffic operates at the standard G-Flex 850 TPS rate if the G-Flex MLR feature is turned on.

3.24 G-Flex MAP Layer Routing (Release 43.1)

For G-Flex MAP Layer Routing message processing controlled by the MAPLYRRTGON option, the MAPLYRRTGON option must be set for the operation code in the incoming message and SCCP CdPA NP=E.214, if NP is present.

The following conditions are no longer required for the G-Flex MAP Layer Routing feature to be applied when the message processing is controlled by the MAPLYRRTGON option:

- The length of the MCC+MNC (Mobile Country Code + Mobile Network Code) in the resulting E.212 IMSI number must be greater than the length of the CC+NDC (Country Code+Network Destination Code) in the E214 MGT number that is converted to the E212 IMSI number. The maximum length of the SCCP CdPA is 15 digits.

If the MCC+MNC length is greater than the CC+NDC length and CdPA is 15 digits, then after E.214 MGT to E.212 IMSI conversion, the resulting number of digits is greater than 15. The last digits may be truncated; in this case, IMSI digits can be taken from the MAP layer.

- The CdPA GTI=2
or

The CdPA GTI=4 and the SCCP CdPA length is 15 digits.

3.25 G-Flex MAP Layer Routing support for ATI using MSISDN (Release 42.0)

The G-Flex MAP Layer Routing support for ATI using MSISDN feature enhances the existing G-Flex MAP Layer Routing (G-Flex MLR) feature by providing the option to route AnyTimeInterrogation (**ATI**) messages using the Mobile Subscriber ISDN Number (**MSISDN**) from the MAP layer of the incoming message.

If the option is provisioned, then the MSISDN is converted to International Format and used for number conditioning and **RTDB** look up. If the option is not provisioned or if the MSISDN number is not present in the MAP layer, then normal G-Flex routing using the SCCP called party number (**CdPA**) is performed.

3.25.1 Feature Control Requirements

The G-Flex MLR feature (Part Number 893-0217-01) must be turned on before the **gflexmaplayerrtg** option can be provisioned.

3.26 G-Flex MLR Support for Additional OpCodes (Release 43.0)

The existing G-Flex Map Layer Routing (G-Flex MLR) feature (Part Number 893-0217-01) is enhanced to support additional MAP Operations:

Table 3-6 New MAP Operations Supported by the G-Flex MLR Feature

MAP Opcode	MAP Message Description	MAP Operation Name
10	Register Supplementary Service	registerSS
12	Activate Supplementary Service	activateSS
13	Deactivate Supplementary Service	deactivateSS
14	Interrogate Supplementary Service	interrogateSS
15	Authentication Failure Report	authenticationFailureReport
57	Restore Data	restoreData
59	Process Unstructured SS Request	processUnstructuredSS-Request
66	Ready for Short Message	readyForSM
67	Purge Mobile Subscriber	purgeMS
85	Send Routing Information for LoCation Service	sendRoutingInfoFor LCS

This enhancement also allows the G-Flex MLR feature to use the MSISDN from the MAP layer if the IMSI is not available for routing Process Unstructured SS Request and sendRoutingInfoForLCS messages.

3.26.1 Feature Control Requirements

No additional feature control requirements are required for this enhancement.

3.26.2 Hardware Requirements

No additional hardware is required for this enhancement.

3.27 Global Option for Connect on INP Query Response (Release 35.0)

Description

The Global Option for Connect on INP Query Response feature adds a global INP option that indicates whether the EAGLE 5 ISS is to send “Connect” or “Continue” messages when an IDP message is received for INP service, the DN digits match, and the HLR ID is present.



Note:

The Connect INP option does not affect the INP Message Relay service.

Hardware Requirements

The Global Option for Connect on INP Query Response feature has no hardware requirements.

Limitations

The Global Option for Connect on INP Query Response feature has no limitations.

3.28 Global Title Modification (Release 28.1) (IP⁷ Release 6.0)

Description

This feature allows the user to modify any part of the Global Title in the outgoing message, other than Encoding Scheme, after **GTT** has been performed. A new **Translation Type (TT)**, **Numbering Plan (NP)**, and/or **Network Address Indicator (NAI)** value can be specified. Also, a specified number of leading digits of the **GT** address can be deleted, and/or a set of specified digits can be added to the beginning of the **GTA**. This is all defined on a per-entry (i.e. **GTA**) basis.

Refer to the *Database Administration Manual - Features* for current details of this feature.

Hardware Requirements

No new hardware is needed to support this feature.

Upgrade Considerations

The **EAGLE** provides an upgrade conversion for customers using the Interim **GT** Modification feature supplied in Release 26.0. **Database** conversions are handled during upgrade.

3.29 Global Title Translation (GTT) (Release 20.0)

The global title translation (**GTT**) subsystem of the **EAGLE** can support the following level of activity.

- 850 messages per second
- 21,000 global title translations per second per system

The maximum number of entries in the global title translation table is 270,000 entries. It is possible to enter all 270,000 entries under one translation type. However, the system works most efficiently when there are 65,536 or fewer **GTT** entries per translation type. While there is no mechanism to limit the number of **GTT** entries to fewer than 65,537 per translation type, the performance of the **GTT** subsystem is not guaranteed when more than 65,536 translations are entered for a single translation type.

3.30 G-Port MNP (Release 26.2)

GSM Mobile Number Portability (**G-Port**) provides mobile subscribers the ability to change the **GSM** subscription network within a portability cluster, while retaining their original **MSISDN**(s).

Throughout the world, an increasing number of governments are mandating that telecommunications network operators support service provider number portability. Service provider portability allows a consumer to change service providers while retaining his phone number. Service provider portability is intended primarily to promote competition among service providers. It applies to both wireline and mobile phone networks. In particular, this feature is focused on service provider portability in **GSM** (Global System for Mobile communications) networks.

While the advent of number portability is good news for consumers, it presents many challenges for network operators. **G-Port MNP** (Mobile Number Portability) minimizes those challenges for **GSM** network operators, while enabling them to efficiently meet their regulatory obligations.

For current details of this feature, refer to the *Features Manual - G-Port*.

3.31 G-Port MNP Circular Route Prevention (Release 28.1)

Description

In some cases, networks may have incorrect number portability data for a subscriber. For example, a subscriber may have ported from network A to network B. Network A has the correct routing information, indicating the subscriber now belongs to network B. However, network B may have incorrect routing information indicating that the subscriber still belongs to network A. In this case, network A routes the call to network B, based on its portability data, but network B routes the call back to network A, based on its incorrect data. This behavior results in a circular route.

This feature provides an option to prevent this from happening.

For current detail on this feature, refer to the *Features Manual - G-Port*.

Hardware Requirements

No new hardware is needed to support this feature.

Upgrade Considerations

The **EAGLE** upgrade process is only responsible for copying new **GSM** tables from removable cartridge to the newly formatted fixed disks.

3.32 G-Port SRI Query for Prepaid (Release 35.2)

G-Port SRI Query for Prepaid Detailed Description

The G-Port SRI Query for Prepaid feature enables the EAGLE 5 ISS to provide portability information to a Service Control Point (SCP) database. This information enables the database to determine the network used by a called subscriber.

The G-Port SRI Query for Prepaid feature enables a user to provision the following Message Signal Unit (MSU) values in the EAGLE 5 ISS GSERV table:

- translation type (TT)—The TT of the called party (CdPA)
- originating point code (OPC)—The OPC from the message transfer part (MTP) layer
- global title address (GTA)—The GTA of the calling party (CgPA)

These values are used to determine whether an SRI should receive G-Port SRI Query for Prepaid service or normal G-Port SRI service.

If the G-Port SRI Query for Prepaid feature is enabled and turned on, an incoming SRI's TT, OPC, and GTA values are compared against the values in the GSERV table. If no match is found, or if no values are provisioned in the GSERV table, normal G-Port SRI processing is performed on the message. If a match is found for one or more of the values, the message is treated as a Prepaid Query.

The G-Port SRI Query for Prepaid feature affects only SRI messages. All other messages, including SRI-SM and SRI-GPRS messages, are processed by normal G-Port service, even if the values in those messages match values in the GSERV table.

After an SRI message is identified as requiring G-Port SRI Query for Prepaid service, the EAGLE 5 ISS performs a Mobile Number Portability (MNP) database lookup on the Mobile Station Integrated Services Digital Number (MSISDN). The results of the lookup are returned to the SCP that originated the query.

A TCAP/MAP error specifically related to a decoding error in the SRI MSISDN parameter causes an "Unsupported/Unexpected Data Value" MAP error. All other TCAP/MAP errors cause the message to be relayed to a Home Location Register (HLR), which then returns the appropriate MAP error based on the status of the subscriber (e.g. Unknown, Barred, etc.)

The message relay is based on information in the G-Port MNP database. SCCP level errors cause the return on a UDTs message to the Prepaid SCP.

This feature requires a Feature Access Key and cannot be turned off once it is turned on.

Hardware Requirements

The G-Port SRI Query for Prepaid feature has the same requirements as those required for the G-Port feature.

3.33 G-Port SRI Query for Prepaid Service Portability (Release 41.1)

Service Portability support for the G-Port SRI Query for Prepaid feature allows GRN digits to be used in place of RN digits during construction of Mobile Station Routing Numbers (MSRNs).

Default Routing Number

A Default Routing Number (Default RN) is introduced for the G-Port SRI Query for Prepaid feature. The Default **RN** option applies to Number Portability, and can be used whether the S-Port feature is on or off. If the S-Port feature is on, then the Default RN applies in cases where Service Portability usage of GRN does not apply for own network subscribers. If the S-Port feature is off, then Default RN digits can be used for own-network subscribers during construction of the **MSRN** instead of the RN/PT=0 or **SP** entity associated with the **RTDB** subscriber entry.

3.34 GR-376 Interface (Release 26.0)

Description

The **GR-376** Support feature provides an optional method of data collection from the **EAGLE STP**. Measurement and reference data is collected with the **EAGLE** and passed to a supplemental Network Data Collection (**NDC**) Q adapter function (**QAF**).

Refer to the *Feature Manual - GR-376* for current information on this feature.

Limitations

The following limitations apply to the initial release of the **GR-376** Support feature:

1. Explicit retrieval of current data objects is not supported.
2. **NDC** data recovery is provided only when at least one **EMAP** originally received the data from an **EMDC DCM** card. No provision is made in the initial release to recover lost data spanning multiple periods.
3. Other than reference data, no **GR-495**-specified data storage objects are supported for this release.
4. No notifications are supported in the initial release.

3.35 Group Ticket Voucher (Release 23.0)

Description

This feature is used to control the traffic from the high-speed **ATM** signaling links to the **ASM-SCCP** cards and **ACMs**. The **ASM-SCCP** cards are used to process messages requiring global title translation. The **ACMs** are used by the **STPLAN** feature to send messages

selected by the gateway screening feature to a remote host for further processing. The message rate from a single high-speed **ATM** signaling link can exceed the capacity of a single **ASM-SCCP** card or a single **ACM**, so the message traffic is split between multiple **ASM-SCCP** cards or **ACMs**.

To determine which card can process the message, each type of message is assigned a group number by the system software.

- **SNM** messages - group 1
- **STPLAN** messages - group 2
- **SCCP** messages - group 3

 **Note:**

Only **SCCP** messages containing a destination point code that is the **EAGLE**'s true point code or one of its capability point codes are affected by this feature.

Each card of each card type is assigned a member number by the system software when the card is entered into the database with the `ent-card` command. This number is not configurable by the user and cannot be displayed with the `rtrv-card` command. This number is used only internally by the software to identify the cards to the group ticket voucher feature. The member number can range from 0 to 31. The number assigned to the card is the smallest number in the range from 0 to 31 that is not already in use. The **STPLAN** and **SCCP** member numbers are assigned independently of each other. The system software does not check the number of **ASM-SCCP** cards entered into the database, but the system software supports a maximum of 25 **ASM-SCCP** cards, and a maximum of 30 **ACMs**. If more than 25 **ASM-SCCP** cards or 30 **ACMs** are entered into the database, the member number of the newly entered card is set to 31.

When a signaling link receives an **SCCP** message or wants to send an **STPLAN** message to a remote host, it sends a request on the **IMT** bus to find either an **ASM-SCCP** card or an **ACM** (depending on the type of message) that has capacity to handle the message. When a card is found that can handle the message, that card answers the request, informs the requesting signaling link that it can handle the message, and sends in its answer the card's group number and member number. When the requesting signaling link receives the answer, it translates the card's group number and member number into the card's **IMT** address, then sends the **SCCP** message or **STPLAN** message to that **IMT** address. The request to find the **ASM-SCCP** card or **ACM** is referred to as a voucher. The answer to the request is referred to as a ticket. The card that is able to handle the message is referred to as the granter.

Sequenced **GTT** class 1 traffic on the high-speed **ATM** signaling links is discarded. The current method for ensuring sequencing in the **EAGLE** is to use only one **ASM-SCCP** card at a time for any one signaling link's stream of sequenced traffic. This imposes a limit on the rate of traffic from any one stream, the speed of an **ASM-SCCP** card, 850 messages per second. Since the message rate of a high-speed **ATM** signaling links far exceeds 850, an **ASM-SCCP** card cannot handle sequenced traffic from a high-speed **ATM** signaling link.

The following figure shows an example of the operation of the group ticket voucher on the **IMT** bus. This example is for an **SCCP** message. The action would be the same for an **STPLAN** message, but the group number would be different.

1. The **ASM-SCCP** cards periodically refresh the hardware grant counters (one for each bus) dynamically based on their individual available capacities.
2. When a high-speed **ATM** signaling link receives an **SCCP** message, the high-speed **ATM** signaling link sends a **TVG** (group ticket voucher) request containing the **SCCP** message group number (group number 3) to find an **ASM-SCCP** card that can handle the **SCCP** message.
3. The request is sent around the **IMT** bus until it finds an **ASM-SCCP** card that can handle the message. In this example, members 0 and 1 have no capacity, but member 2 does. Member 2 changes the **TVG** (group ticket voucher) request, a voucher packet, to a ticket packet, changes the group number of the packet to the **ASM-SCCP** card's member number, member 2, and decrements the card's grant counters for each **IMT** bus. When member 2's grant counter reaches zero, that **ASM-SCCP** card has no more capacity for handling messages and the next available member with capacity begins granting tickets.
4. The ticket packet returns to the high-speed **ATM** signaling link requesting the service. The high-speed **ATM** signaling link translates member 2's group number to the card's **IMT** address and sends the **SCCP** message to that card.

Figure 3-4 Group Ticket Voucher Example

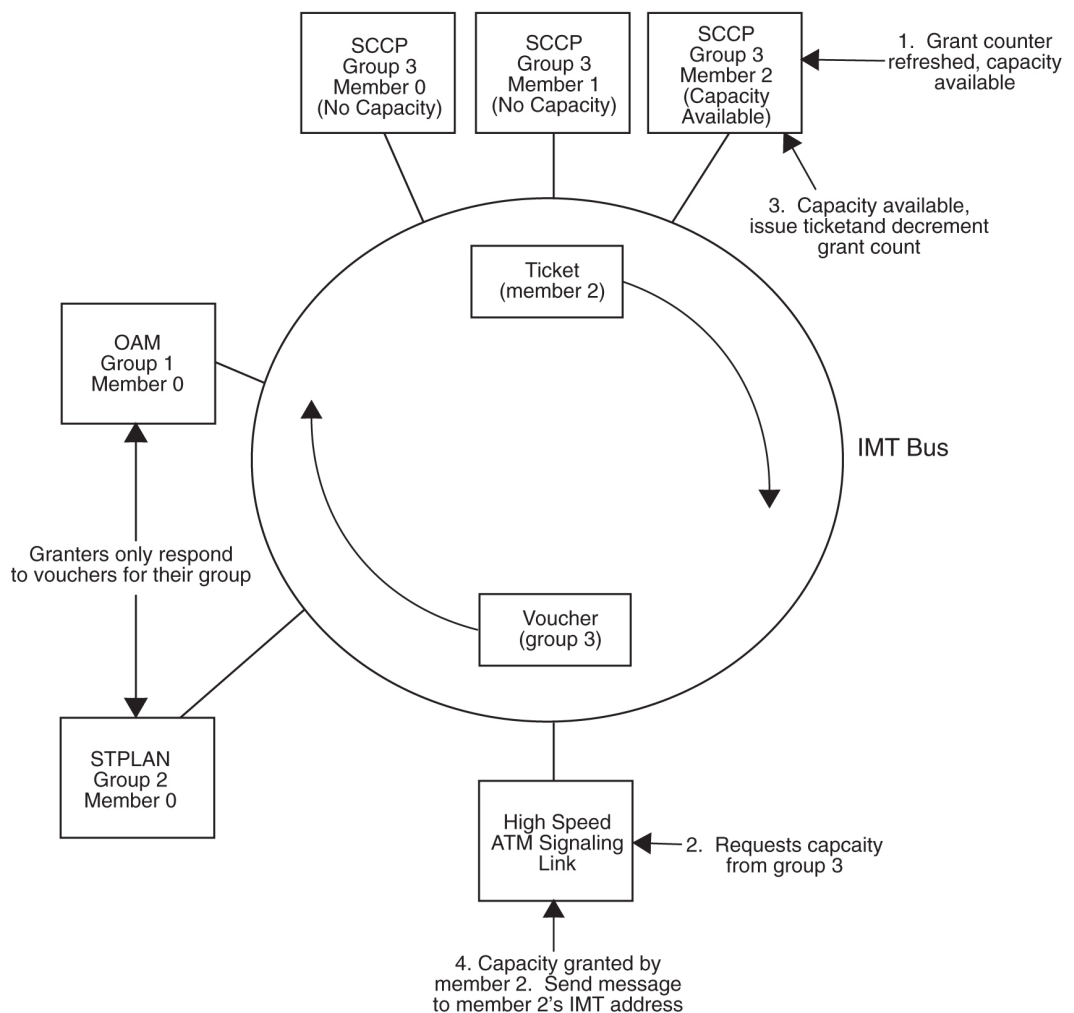

Measurements

MSULOST3

The **MSULOST3** measurement is currently used to count the number of **MSUs** discarded when a card does not have an **SCCP** assignment or when the linkset-on-hold buffer is full. In Release 23.0, this measurement also counts the number of **SCCPMSUs** that are discarded by the group ticket voucher feature on the high-speed **ATM** signaling links. The **SCCPMSUs** are discarded under these conditions:

- All Class 1 (sequenced) **SCCP** traffic sent to the **EAGLE**.
- A Class 0 **SCCP** message for **EAGLE** arrives when the **SCCP** group ticket voucher queue is full.
- A **SCCP** message in the **SCCP** group ticket voucher queue is more than 2 seconds old.

The **MSULOST3** measurement is displayed in these measurement reports:

SYSTOT-STP - **STP** system total measurement report

MTCD-STP - **STP** daily maintenance measurement report

MTCDTH-STP - **STP** day-to-hour maintenance measurement report

NM-STP - **STP** network management measurement report

SLANDISC1

The **SLANDISC1** measurement is currently used to count the number of **MSUs** that have not been copied to a remote host because the **STPLAN** feature is disabled. In Release 23.0, this measurement also counts the number of **STPLANMSUs** discarded by the group ticket voucher feature on the high-speed **ATM** signaling links. The **STPLANMSUs** are discarded under these conditions:

- An **STPLANMSU** arrives when the **STPLAN** group ticket voucher queue is full.
- An **STPLANMSU** in the **STPLAN** group ticket voucher queue is more than 2 seconds old.

The **SLANDISC1** measurement is displayed in these measurement reports:

SYSTOT-STPLAN - **STPLAN** system total measurement report

MTCD-STPLAN - **STPLAN** daily maintenance measurement report

MTCDTH-STPLAN - **STPLAN** day-to-hour maintenance measurement report

AVL-STPLAN - **STPLAN** availability measurement report

3.36 Group Ticket Voucher for SCCP Cards (Release 27.0)

Description

Group Ticket Voucher replaces **SCCP** Load Balancing as a method of providing **SCCP** service to **LIM** cards.

In the current **EAGLE** implementation, an **EAGLE** Low Speed **LIM** (**LSL**) card is assigned to one **SCCP** card based on the 16:1 **LIM** - **SCCP** Engineering rule via load balancing (**LB**). The **LSL-SCCP** assignment may change from time to time, but the

engineering rules are maintained at all times. This poses a problem to customers, forcing them to purchase unnecessary hardware (**SCCP**) so they can meet the engineering rules for **LB**. The Group Ticket Voucher (**TVG**) solution currently implemented with **HSL/SCCP** and **HSL/SLAN** card assignments alleviates this problem.

The Release 27.0 **TVG** solution is an extension of the Ticket/Voucher solution to the **SNM** multicast problem. The Ticket/Voucher concept uses an **IMT** hardware-based request/grant scheme to provide a flow control solution, which allocates message capacity at hardware speeds. Each grant allows a single message to be sent to the granter. The "group" concept is added to provide for multiple groups of granters, each supporting one particular message type.

Each granter has a group **ID** that is based on the message type it supports, and will only grant capacity to **TVG** requests which match its group number. Since the **TVG** mechanism is designed to provide a one-to-many assignment, there will typically be more than one granter for a group. **SNM**, by its nature, is the only message type, which will have a single granter (**OAM**).

Each message type supported by **TVG** will be assigned to a particular group. A card requesting capacity from a particular group will build a **TVG** request, and set the group number in the request based on the message type. The group numbers are defined as follows:

- **SNM** group 1
- **SLAN** group 2
- **SCCP(GTT)** group 3
- **REROUTE** group 31

In addition to the group number, each granter is assigned a member number, which identifies the granter. The member number is unique within a group, but may be repeated within other groups in the **EAGLE**. When a granter card grants capacity, it changes the voucher packet into a ticket. It also changes the group number in the packet to its member number. When the **TVG** request returns to the requester as a ticket, the requester uses the member number along with the group number it saved to look up the **IMT** address of the granter. The **IMT** address provides the assignment, which allows the requester to forward the message to the granter.

Upgrade Considerations

LB is supported during upgrade to Release 27.0 only.

Limitations

1. Class-1 **GTT** traffic on will be allowed, but sequencing will not be guaranteed.
2. The number of **TVG** requests that can be made per card is a function of the number of cards in the system, and decreases as the number of active cards increase. It is approximately $1/(N \times 10^{-6})$ for N cards. For a system with 250 **IMT** addresses it is limited to about 3300 requests/second. This limitation could become a bottleneck if the number of cards on the **IMT** bus were increased.

3.37 GSM MAP Screening (Release 26.1)

Description

Traditionally, **STP** message screening has been limited to the **MTP** and **SCCP** levels; this has been sufficient to meet operators' needs. However, **GSM** mobile operators have an increasing need for screening at the Mobile Application Part (**MAP**) level. This need is driven by advanced network capabilities and proliferating roaming agreements.

New features that require this enhanced screening capability are Inter-operator Short Message Service (**SMS**) and **Any Time Interrogation (ATI)**. The **GSM MAP Screening** feature focuses on solving the screening needs associated with **ATI**, which is defined in **MAP** version 3. An **ATI** message allows an external server to interrogate an **HLR** and obtain information about the location and/or state of a **GSM** subscriber. It may be desirable to control which external entities can request this information, and what information they can request before allowing the message to pass through to the **HLR**.

The **EAGLE**-based solution to this problem is designed to allow the user to provision which **MAP SSNs** are affected, which **MAP** op codes to screen, which origination points are allowed, and which error messages to use.



Note:

This feature is only applicable for **ITU** implementations.

Refer to the *Database Administration Manual - Features* for current information on this feature.

Hardware Requirements

To meet optimum performance in "worst case" scenarios under heavy traffic conditions, it is recommended that **GSM MAP Screening** be used in conjunction with high performance **SCCP** hardware (**DSMs**). There is, however, no specific requirement restricting **GSM MAP Screening** to **DSM** hardware, since a throttling mechanism protects system integrity.

Upgrade Considerations

- New tables relating to **GSM MAP Screening** must be created on the upgraded disk.
- the **GSM MAP Screening** feature bit should be defaulted to **OFF** on new upgraded disks.
- The **STPOPTS** value of **GSMSDECERR** shall be **PASS** after upgrade.
- The **STPOPTS** value of **GSMDFLT** shall be **PASS** after upgrade.

Limitations

1. Overlapping range entries cannot be provisioned.

2. There is no cross-checking between the individual entry table and the range table when numbers are provisioned. The individual table entries are exceptions to the range table. Thus, if an individual number is provisioned that is already part of a range, automatic splitting of the range entry will not occur. (This is not necessarily a limitation.)
3. Per-server measurements are not provided for range table entries, and no per-server measurement will be pegged when a match occurs in the range table.
4. This feature is applicable only for **ITU** implementations.
5. A given **GTA** may be entered in the **MAP** Screening table only once.

3.38 GSM MAP Screening Duplicate/Forward (Release 29.0)

Description

The **GSM MAP** Message Duplicate/Forward feature extends the capabilities of **GSM MAP** Screening by allowing **MAP** messages to be routed, discarded, duplicated, or forwarded based on the provisioned screening criteria. This gives the **EAGLE** the ability to offload or copy certain types of **MAP** messages to an attached processor (such as a **SCP**) based on the **MAP** Opcode and/or **Calling Party Address**.

For these advanced services on **MAP** messages, targeting messages based only on **MTP** level screening could lead to many messages being sent to the external platform unnecessarily, possibly impacting the performance of the **STP** or the external platform. In order to allow a finer granularity in message selection, a method is needed to target only specific **MAP** messages. Furthermore, it is desirable to achieve this using standard message structures (i.e. **SS7**).

Refer to the *Database Administration Manual - Features* for current information on this feature.



Note:

It should be noted that the **GSM MAP** Message Duplicate/Forward feature is independent of the **EAGLE**'s **STPLAN** and **DTA** features. It operates and is provisioned in an entirely different manner than either of these existing features.

Hardware Requirements

No new hardware is needed to support this feature.

Upgrade Considerations

MAP screening tables that were built under the Release 26.1 version of **MAP** Screening and used the previous default value of **NONE** for the **FORBID** parameter will not have that value changed to **ALL** as a result of an upgrade to this version of **MAP** Screening. (Those original entries will still have **FORBID** = **NONE**, even though new entries after the upgrade will default to **FORBID**=**ALL**.)

Limitations

The first implementation of this feature is limited in the following ways:

1. Only works for **ITU** messages.

2. State and Location are the only **GSM** Map parameters that screening may forbid.
3. **ATI** Error responses are the only type of messages that may be sent as a screening rejection response.
4. We do not screen on **NP** and **NAI** on a per origination basis, but rather on a per Map Op-Code basis.
5. Measurements are taken on an existing 30-minute schedule and are not reported real-time.
6. During extremely high traffic conditions where 850 messages per second require **GSM** Map screening on 1 **SCCP** card, and other **SCCP** processor intensive features are also in very rare worst case conditions, **GSM** Map Screening may be throttled to keep **SCCP** processor utilization below 70%. There will be no alarm or warning when this condition occurs.

3.39 GSM MAP SRI Redirect to Serving HLR (Releases 31.11, 34.0)

Description

This feature provides the capability to resolve the incompatibility introduced by the proprietary implementation of the **GSM MAP SRI** message. This feature is an extension to the **G-Port** Mobile Number Portability (**G-Port MNP**) Protocol. Therefore, the feature is compatible with other **MNP** enhancement features provided to date, including the "**G-Port MNP Circular Route Prevention**," "Portability Check for Mobile Originated **SMS**" and "Pre-paid **SMS** Intercept" features.

Hardware Requirements

Refer to the hardware baseline.

Limitations

Because this is an **ON**-only feature, to remove the affect of the feature from call processing, all the VendorID List entries must be deleted.



Note:

This is similar to the behavior of several other protocol features.

3.40 GTT Actions (Release 42.0)

The GTT Actions framework increases the functionality of the Global Title Translation (GTT) and Flexible Linkset Optional Based Routing (FLOBR) features. GTT Actions supports all functionality provided by the Enhanced GSM MAP Screening (EGMS) feature except for screening based on Forbidden Parameters in ATI messages.

 **Note:**

Both GTT Actions and **EGMS** are supported and can co-exist in the system.

The GTT Actions framework consists of three separate features:

- GTT Action - DISCARD – there are three types of discard:
 - Discard – discard message with no return error
 - UDTS – discard message and send UDTS/XUDTS independently of the value of the Message Handling flag in the MSU
 - TCAP Error – return a specified TCAP Error for the opcode

The functionality performed by the GTT Action - DISCARD feature was originally performed by the Origin-based SCCP Routing (OBSR) feature. All entries that were previously provisioned using the OBSR feature will be converted to a GTT Action and Action Set.

- GTT Action - DUPLICATE
Routes a copy of the message to a specified duplicate node. The original message is always routed based on GTT/DB data. A copy of the message is routed to a specified duplicate node if the node is available.
- GTT Action – FORWARD
Routes the original message to a specified forward node instead of the destination indicated by the GTT/ DB data. If the Forward node is not available, a configurable default action can be used. This action could result in an error response (TCAP Error or UDTS), silent discard, or routing based on default GTT/DB data.

The GTT Actions framework allows the creation of a GTT Action Set, which is a list of actions that are performed on a message. A GTT Action ID is used to define the action and its characteristics.

The GTT Actions framework also provides the following capabilities:

- Advanced GTT Modification Enhancements
Data, including Calling Party data, used to configure the Advanced GTT Modification (AMGTT) feature is maintained in a new GT Modification (GTMOD) table.
The AMGTT feature is also enhanced to allow deletion of a trailing **0** in the Global Title Address (GTA) during GTT modification if the conversion from **GTI(x)=2** to **GTI(x)=4** occurs. Encoding scheme (ES) calculations are performed on the remaining digits after the **0** is deleted.
- Non-overlapped GTT Selectors
ITU GTT selectors (i.e ITU-I, ITU-N, ITU-N24, ITU-I Spare and ITU-N Spare) with different domains can be provisioned for the same GTI value and translation type (**TT**) independently.
- Per-Path Measurements
Per-Path measurements, the equivalent of the EGMS Per-Path measurements, can be performed by GTT. These measurements provide counts for GTT Actions that match a pre-defined combination of CgPA **GTA**, **CdPA** GTA, and Opcode values. This functionality is not specific to FLOBR or GTT Actions, but can be specified for any GT translation. If CdPA-only GTT is the only service turned on, having per-path measurements is not applicable, since there is no searching on **CgPA** or Opcode.
- Reference Count for GTTSETS

The response of the `dlt-gttset` command is enhanced by maintaining an internal reference count for each GTTSET. When a GTTSET is referenced or de-referenced, the reference count for that GTTSET is incremented or decremented by 1.

- Support of **xlat=none** Translations
A GT entry containing GTT Action or GT Modification data can be provisioned when translation data is not present. This ability also allows loadsharing of message-relayed EPAP-based features. If **xlat=none** is provisioned, then both an MRN set and a MAP set can be provisioned against the translation.
- Unique GTT Selectors
GTT Selectors with ITU-I Spare and ITU-N Spare domains can be provisioned using the `ent/chg/dlt/rtrv-tt` and `ent/chg/dlt/rtrv-gttset` commands.

3.40.1 Feature Control Requirements

- A FAK for the desired Part Number:
 - GTT Action - DISCARD: 893-0275-01
 - GTT Action - DUPLICATE: 893-0276-01
 - GTT Action - FORWARD: 893-0375-01
- The Enhanced GTT (EGTT) feature bit must be turned on before any of the GTT Action features can be turned on.
- The GTT Action features cannot be turned off after they have been turned on.
- A temporary FAK cannot be used to enable any of the GTT Action features.

3.40.2 Hardware Requirements

The GTT Actions framework requires DSM or E5-SM4G cards running the SCCP application.

 **Note:**

The GTT Action - DUPLICATE feature requires E5-SM4G cards. If a DSM card is present in the system, then the GTT Action - DUPLICATE feature cannot be enabled. If a DSM card is inserted in the system after the GTT Action - DUPLICATE feature is enabled, then the card will auto-inhibit.

3.40.3 Limitations

High load conditions may occur if a major percentage (90% or higher) of MSUs are subjected to GTT Actions functionality, and more than 2 Duplicate Actions are provisioned for each GTT Action set. If high load conditions occur when multiple Duplicate Actions are provisioned, then the E5-SM4G card may experience overload. The system monitors the processing load on the card, and will temporarily disable Duplicate processing under these conditions. Only processing of GTT Duplicates is disabled: normal GTT routing, GTT Forward, and GTT Discard actions are not affected.

After the overload condition subsides, GTT Duplicate Action processing is restored. Alarms are used to indicate when Duplicate Action processing is stopped and restored.

3.41 GTT Actions to Trigger Services (Release 46.0)

The GTT Actions to Trigger Services feature provides new GTT Actions to allow triggering EAGLE services, such as G-Flex or G-Port. Prior to this feature, EAGLE servers were primarily accessible or triggered by the table SRVSEL entries. The GTT Actions to Trigger Services feature allows a service to be triggered as a GTT Action based on either the usual GTT rules or after FLOBR/TOBR execution. The GTT Actions to Trigger Services feature is useful when combining advanced routing features with Number Portability lookup or with HLR Router lookups.

3.42 GTT by TT Measurements and GR-376 Enhancements (Release 26.0)

Description

This section combines discussion of *two* Release 26.0 features:

- **GTT by TT Measurements**
- **GR-376 Enhancements**

The **GTT by TT Measurements** feature allows **EAGLE** customers to collect measurements and generate reports of **GTT** activity by **Translation Type (TT)**. **GTTs-per-TT** reports are available from the **EAGLE** terminal, and via the **SEAS** interface and the **GR-376** interface. **GTTs-per-TT** reports are available for all provisioned translation types.

The **GTT by TT Measurements** feature provides **EAGLE/SEAS** support for the **GTT-by-TT** capability.

The **GR-376 Enhancements** feature provides the **GR-376** support for **GTT-by-TT**.

The following figure provides a high-level diagram of the capabilities implemented by **GTT by TT Measurements** feature and the **GR-376 Enhancements** feature:

Figure 3-5 Concept Diagram

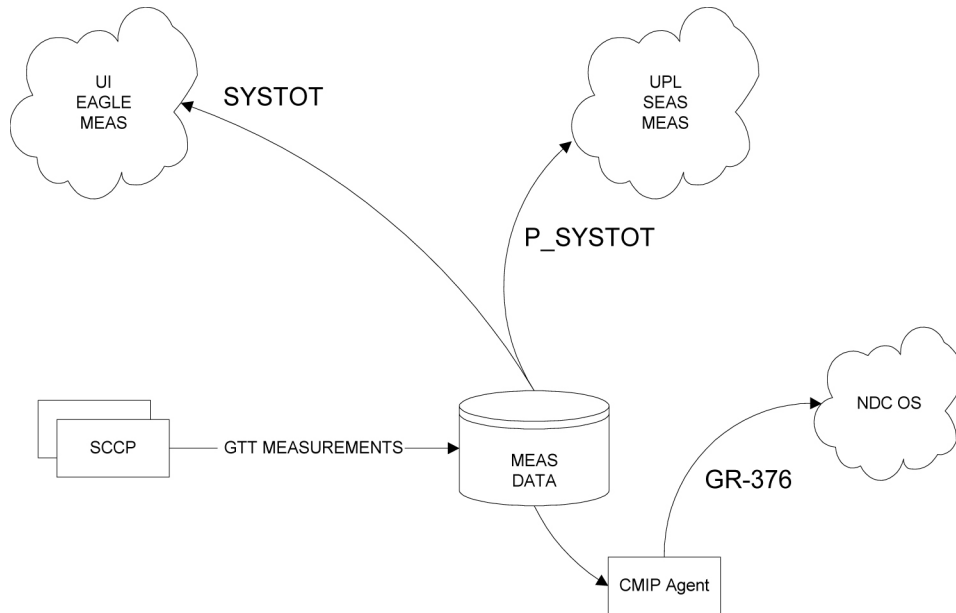

GTTs are pegged in the **SCCP** card for each **TT** and are stored on the fixed disk in 30-minutes intervals and retained for a 24-hour period. The **SYSTOT** report and the **P_SYSTOT** schedule are existing capabilities for reporting **STP**-wide measurement data.

The **TT** entity type has been expanded to report **GTTs** performed/not translated per **TT** for 256 known translation types. This feature provides the customer with information that can be used for service growth trends and potential revenue collection.

A new parameter (: **TT=x**) has been added to the `rept-meas` command to enable the user to specify a translation type to be reported. The demand report requires that a **TT** be specified, while scheduled reports will provide **GTTs** per **TT** for all **TTs**. This feature provides scheduled and demand reports of **GTTs**-per-**TT** to the **EAGLE UI** for half-hourly measurements. Half-hourly **GTTs**-per-**TT** measurements are provided to the **SEAS** interface.

The following table specifies the **EAGLE** interpretation of **SYSTOT-TT** registers that are reported per **TT** by the **GTT by TT Measurements** feature and the **GR-376 Enhancements** feature.

Table 3-7 SYSTOT-TT Register Definition

Register	Description	EAGLE Interpretation
GTTPERFD	GTTs Performed	The total number of MSUs that successfully completed global title translation
GTTUN0NS	GTTs Unable to Perform – Diagnostic 0: No Translation for Address of Such Nature	Total number of times that the specified translation type in an MSU was not supported by the STP or the form of the GTT was incorrect for the given translation type.

Table 3-7 (Cont.) SYSTOT-TT Register Definition

Register	Description	EAGLE Interpretation
GTTUTTNF	GTTs Unable to Perform – TT not found	Not supported
GTTUINV	GTTs Unable to Perform – Invalid GT format	Not supported
GTTUN1NT	GTTs Unable to Perform – Diagnostic 1: No Translation for This Address	The number of times that a match for the global title could not be found in the translation table.
GTTUGTAR	GTTs Unable to Perform – Incorrect GTA Reference	Not supported
GTTUDPCR	GTTs Unable to Perform – Incorrect Ordered DPC Reference	Not supported
GTTUNABL	GTTs Unable to Perform – All Diagnostics	Not supported

Upgrade Considerations

During upgrade, measurement collection is inhibited (except for **GR-376**) and any measurement data collected prior to the upgrade is lost. This is the historical method of handling measurement tables during upgrade. No change in this processing is anticipated for this feature or release. In addition, all obsolete measurement tables are removed from the fixed disk by the upgrade process.

Implementation of the **GTT** by **TT** measurements feature in the **EAGLE** includes the creation of a new table to store the 30-minute **GTTs** per **TT** measurement data. The new table (**M30_TT.MEA**) resides on the fixed disk and on the measurements removable. The measurement data captured in the table currently requires 16 bytes of storage per entry. The remaining 48 bytes are reserved for future use.

During upgrade, the table will not be present on the previous revision **TDM**, but is created on the standby **TDM** during the format disk process. No additional processing is required during the upgrade for this table.

3.43 GTT Error Reporting Enhancements (Release 21.0)

The **UIM** message formats for global title translation (**GTT**) error messages have been updated to include more useful information for diagnosing problems in the network. The affected messages include:

- **SCCP UDT**
- **SCCP** Message
- **SCCP** Class
- **SCCP** CDPA
- **SCCP** Routing
- **SCMG - SCCP** Management

3.44 GTT Loadsharing between ITU Network Types (Release 40.1)

The GTT Loadsharing between ITU Network Types feature allows GTT loadsharing to occur between ITU-National (ITU-N), ITU-N spare, ITU-International (ITU-I), and ITU-I spare point codes within the same MAP or MRN set.

This feature also allows different alias combinations to be provisioned, such as an ITU-N spare alias for an ITU-N destination point code. The feature supports the current maximum of two alias point codes per destination point code.

The feature adds support for provisioning additional alias combinations for ITU-I, ITU-N, ITU-I spare, and ITU-N spare true point codes and their spare types, including:

- ITU-N spare alias for ITU-N true point code
- ITU-N alias for ITU-N spare true point code
- ITU-I spare alias for ITU-I true point code
- ITU-I alias for ITU-I spare true point code
- the ability to provision an ITU-I and an ITU-I spare alias for an ITU-N/ITU-N spare point code
- the ability to provision an ITU-N and an ITU-N spare alias for an ITU-I/ITU-I spare point code.

These new alias combinations allow MTP-routed and GT-routed messages to cross spare-non spare network boundaries. SCCP conversion of CgPA point code, conversion of concerned point code (network management messages) and affected point code (SCMG messages) are also supported for the new alias combinations.

3.45 GTT Loadsharing to 32 Destinations (Release 36.0)

Description

The **GTT** Loadsharing to 32 Destinations feature increases loadsharing destinations for intermediate and final **GTT** from 8 to 32 destinations.

The feature allows each **Mated Application Table (MAP)** set or **Mated Relay Node (MRN)** set that is used for loadsharing to be associated with up to 32 destination point codes in the **EAGLE 5 ISS Destination** table.

The support of 32 destination point codes does not increase the maximum number of supported entries in the **MAP** table or **MRN** table.

Hardware Requirements

The **GTT** Loadsharing to 32 Destinations feature requires **DSM** cards.

Limitations

None

3.46 GTT Loadsharing with Alternate Routing Indicator (Release 40.1)

The GTT Loadsharing with Alternate Routing Indicator (GTT LS ARI) feature allows the routing indicator (RI) in the outgoing message to be provisioned without depending on whether the primary GT translation resulted in Final or Intermediary GTT. This feature provides a backup SCCP loadsharing mechanism if the primary SCCP loadsharing mechanism does not route the message.

This feature allows loadsharing relationships to be established between the MAP and MRN table in that the MAP set and MRN sets allow provisioning of MRN and MAP sets, respectively, as the Alternate Mate RI if the point codes in the MAP or MRN table are unavailable.

If the feature is enabled, then the MRN table allows access to the MAP table to perform a secondary mate search if all point codes in a given MRN set are unavailable. The MAP table also allows access to the MRN table to perform a secondary mate search if all point codes provisioned in a given MRN set are unavailable.

If a point code or a point code/subsystem number combination is specified, but an MRN set or MAP set is not specified, then the default MRN set or MAP set is used.

Only one secondary mate search can be performed per translation.

3.46.1 Feature Control Requirements

The GTT LS ARI feature has the following feature control requirements:

- FAK for Part Number 893-0274-01
- The feature cannot be enabled with a temporary FAK.
- The Intermediate GTT Loadsharing feature (893-0069-01) and the GTT feature bit must be turned on before the GTT LS ARI feature can be enabled.
- The feature can be turned on and off.

3.46.2 Limitations

The GTT LS ARI feature does not support local subsystem numbers (e.g., LNP, INP, EIR, V-Flex).

3.47 GTT Table Increase (Release 29.0)

Description

This feature increases the number of Global Title Table entries. The **EAGLE GTT** capacity can be increased from 270,000 to a maximum of 400,000 Global Title Table entries on **TSMs** (or a combination of **TSMs** and **DSMs**), and from 270,000 to a maximum of 1,000,000 Global Title Table entries on **DSMs**. The **GTT Table Increase Feature** is also referred to as the **XGTT Feature (Expanded GTT)**.

XGTT is a controlled feature associated with quantity. **XGTT** must be initialized to default quantity level 270,000 **GTT** table entries. One of two Part Numbers is required to enable

XGTT. If the system meets minimum hardware requirements, the **XGTT** feature can be enabled at different quantity levels. One Part Number increases the **GTT** table size from 270,000 entries to 400,000 entries (893-0061-01); the other increases the **GTT** table size from 270,000 or 400,000 entries to 1,000,000 entries (893-0061-10).

Hardware Requirements

All existing **SCCP ASM** cards must be replaced with **SCCP TSM** or better (**DSM**) equipment when activating **XGTT**. The 400,000 feature key allows **TSMs** and/or **DSMs**; the 1,000,000 **GTT** feature key allows **DSMs** only.

All existing **SCCP ASM** cards must be replaced with **SCCP TSM** or better (**DSM**) equipment when activating **XMAP**.

Note:

The **EAGLE** will not allow the feature access key to be activated unless the required **SCCP** hardware is present in the system. Also, the **EAGLE** does not allow the feature access key to be activated unless both the active and standby **OAM** is a **GPSM-II**.

Caution:

Never install or initialize **MCAP** cards in **MASP** slots 1113 and 1115 after features that require **GPSM-II** cards are provisioned. Attempting to initialize **MCAP** cards with **GPSM-II** features provisioned will cause a system outage. Before replacing an existing **GPSM-II** card in a **MASP** slot (1113 and 1115) contact Tekelec Customer Service.

The **EAGLE** will auto-inhibit an **SCCP** card that does not meet the hardware requirements for the respective **GTT** Table size. This requirement is only applicable after at least one of the two feature access keys is enabled.

enabled for 400,000 or 1,000,000 **GTT** entries.

3.48 GTT UIM 21 Digit Length Enhancement (Release 29.0)

Description

This enhancement increases the length of **GTT UIMs** from 10 digits to 21 digits, providing more space for the **SCCP** called or calling party address to be displayed.

Hardware Requirements

No new hardware is needed to support this feature.

3.49 GTTSET Table Increase (Release 46.0)

Table GTTSET Increase increases the GTTSET table capacity from 2,000 to 10,000 entries.

3.50 GWS Error Reporting Enhancement (Release 21.0)

The **UIM** message format for gateway screening messages is expanded to provide the user with more information. **UIMs** resulting from gateway screening failures include:

- **Link Set Name**
- **Originating Point Code (OPC)**
- **Destination Point Code (DPC)**
- **Service Information Octet (SIO)**
- **Gateway Screening Reference**

The following rules apply to the **SIO** information:

Table 3-8 SIO Information

SIO	SSN	Additional Information Included in UIM
0,1,2	N/A	The H0 and H1 heading codes, and the concerned point code
3	1	The SCCP management (SCMG) message type, message length, multiplicity, concerned point code (CPC) and subsystem
3	1	The message type, called party address (CDPA) and all sub-fields, calling party address (CGPA) and all sub-fields
> 3	N/A	The first 24 bytes of the MTP user data (the data following the SLS)

3.51 GWS Stop Action for MTP Routed Messages (Release 41.1)

The GWS Stop Action for MTP Routed Messages feature provides a new **sccp** Gateway Screening (**GWS**) stop action. This stop action allows IS41-based features to process MTP-routed traffic. GWS rules are used to filter MTP-routed SCCP messages on a per linkset basis. UDT, UDTS, XU DT, and XU DTS messages are then forwarded to Service Module cards for processing.

The GWS Stop Action for MTP Routed Messages feature includes a new MTP Routed GWS Stop Action feature (Part Number 893-0356-01), which must be enabled before the **sccp** stop action can be provisioned. The feature must be turned on before message processing can occur.

As part of the GWS Stop Action for MTP Routed Message feature, the existing MTP Msgs for SCCP Apps (**MTPR**) feature (Part Number 893-0174-01) is enhanced to become an ON/OFF feature. The remaining functionality of the MTPR feature is not changed.

The MTPR feature takes precedence over the MTP Routed GWS Stop Action feature. If the MTPR feature is turned on, then all SCCP messages are forwarded to Service Module cards without the **sccp** GWS stop action being executed, even if the MTP Routed GWS Stop Action feature is turned on.

After provisioning, the **sccp** stop action can be used by the following features:

- A-Port

- G-Flex
- Info Analyzed Relay ASD
- Info Analyzed Relay Base
- Info Analyzed Relay GRN
- Info Analyzed Relay NP
- IS41 GSM Migration
- ITUN-ANSI SMS Conversion
- MNP Circular Route Prevention
- MO SMS ASD
- MO SMS B-Party Routing
- MO SMS GRN
- MO-based IS41 SMS NP
- MO SMS IS41-to-GSM Migration
- MTP MAP Screening
- MT-based IS41 SMS NP



Note:

The A-Port, G-Flex, IS41 GSM Migration, MO SMS ASD, MO SMS B-Party Routing, MO SMS GRN, MO-based IS41 SMS NP, or MO SMS IS41-to-GSM Migration feature must be turned on before the MTPR feature can be enabled.

3.51.1 Feature Control Requirements

- FAK for Part Number 893-0356-01 to enable and turn on the MTP Routed GWS Stop Action feature
- The GTT feature bit must be turned on before the MTP Routed GWS Stop Action feature can be enabled.
- A temporary FAK cannot be used to enable the feature.
- The feature can be turned on and off.
- The **sccp** GWS Stop Action can be provisioned only after the feature is enabled.

3.52 Hardware Maintenance Phase for E5-ATM Card (Release 46.6)

E5-ATM cards (870-1872-xx) are not supported in Release 46.6. E5-ATM cards must be removed and replaced by the E5-ATM-B (P/N 870-2972-01) card before the upgrade will proceed. The functionality of the E5-ATM card is performed by the E5-ATM-B card.

3.53 Hardware Maintenance Phase for E5-E1T1 Card (Release 46.6)

E5-E1T1 cards (870-1873-xx) are not supported in Release 46.6. E5-E1T1 cards must be removed and replaced by the E5-E1T1-B (P/N 870-2970-xx) or SLIC (P/N 7094646) card before the upgrade will proceed. The functionality of the E5-E1T1 card is performed by the E5-E1T1-B or SLIC card.

Note:

If upgrading from Release 46.3, E5-E1T1 cards must be removed and replaced by E5-E1T1-B cards. If upgrading from Release 46.5, E5-E1T1 cards must be removed and replaced by either E5-E1T1-B or SLIC cards.

3.54 Hardware Maintenance Phase for E5-ENET Card (Release 46.6)

E5-ENET cards (870-2212-xx) are not supported in Release 46.6. E5-ENET cards must be removed and replaced by the E5-ENET-B (P/N 870-2971-xx) card (or the SLIC (P/N 7094646) card for IPSP) before the upgrade will proceed. The functionality of the E5-ENET card is performed by the E5-ENET-B or SLIC card.

3.55 Hardware Maintenance Phase for E5-IPSM Cards (Release 46.5)

E5-IPSM cards (870-2877-xx) are not supported in Release 46.5. E5-IPSM cards can remain in the EAGLE at the start of the upgrade to Release 46.5, but must be removed and replaced by the E5-ENET-B (P/N 870-2971-xx) or the SLIC (P/N 7094646) card at the completion of the upgrade. The functionality of the E5-IPSM cards is performed by the E5-ENET-B or the SLIC card.

3.56 Hardware Maintenance Phase for E5-SM4G Cards (Release 46.6)

E5-SM4G cards (870-2860-xx) are not supported in Release 46.6. E5-SM4G cards must be removed and replaced by the E5-SM8G-B (P/N 870-2990-xx) card or the SLIC (P/N 7094646) card before the upgrade will proceed. The functionality of the E5-SM4G card is performed by the E5-SM8G-B or SLIC card.

3.57 Hardware Maintenance Phase for E5-TSM Card (Release 46.6)

E5-TSM cards (870-2943-xx) are not supported in Release 46.6. E5-TSM cards must be removed and the GLS function enabled in the OAM. With this maintenance phase, the GLSHC GPL is discontinued. The functionality of the E5-TSM card is performed by the E5-MASP card if the Integrated GLS control feature is enabled.

3.58 Hardware Maintenance Phase for EAGLE ATM Cards (Release 46.0)

EAGLE ATM cards (870-1293-xx and 870-2455-xx) are not supported in Release 46.0. The system cannot be upgraded to Release 46.0 if ATM cards are installed. The functionality performed by the ATM cards is performed by E5-ATM (Part Number 870-1872-xx) and E5-ATM-B (Part Number 870-2972-xx) cards.

As part of this Maintenance phase, the BPHCAP, BPHCAPT, ATMANSI and/or ATMITU GPLs are not supported in Release 46.0.

3.59 Hardware Maintenance Phase for EAGLE DCM cards (Release 46.0)

EAGLE DCM cards (870-1945-xx) are not supported in Release 46.0. The system cannot be upgraded to Release 46.0 if DCM cards are installed. The functionality performed by the DCM cards is performed by E5-ENET (Part Number 870-2212-xx) and E5-ENET-B (Part Number 870-2971-xx) cards.

As part of this Maintenance phase, the BPDCM, BPDCM2, IPLIM, IPLIMI, IPGWY, IPS, VXWSLAN and EROUTE GPLs are not supported in Release 46.0.

3.60 Hardware Maintenance Phase for EAGLE DSM cards (Release 46.0)

EAGLE DSM cards (870-1984-xx) are not supported in Release 46.0. The system cannot be upgraded to Release 46.0 if DSM cards are installed. The functionality performed by the DSM cards is performed by E5-SM4G (Part Number 870-2860-xx) and E5-SM8G-B (Part Number 870-2990-xx) cards.

As part of this Maintenance phase, the BPDCM, BPDCM2 and VSCCP GPLs are not supported in Release 46.0.

3.61 Hardware Maintenance Phase for EAGLE E1/T1 MIM cards (Release 46.0)

EAGLE E1/T1 MIM cards (Part Number 870-2198-xx) are not supported in Release 46.0. The system cannot be upgraded to Release 46.0 if E1/T1 MIM cards are

installed. The functionality performed by the E1/T1 MIM cards is performed by E5-E1T1 (Part Number 870-1873-xx) and E5-E1T1-B (Part Number 870-2970-xx) cards.

As part of this Maintenance phase, the BPMPLT and SS7ML GPLs are not supported in Release 46.0.

3.62 Hardware Maintenance Phase for EAGLE EDCM cards (Release 46.0)

EAGLE EDCM cards (870-2372-01/870-2372-08/870-2372-13) are not supported for any applications in Release 46.0. SIGTRAN support on these cards was removed in Release 45.0. The system cannot be upgraded to Release 46.0 if EDCM cards are installed. The functionality performed by the EDCM cards is performed by E5-ENET (Part Number 870-2212-xx) and E5-ENET-B (Part Number 870-2971-xx) cards.

As part of this Maintenance phase, the BPDCM, BPDCM2, IPLIM, IPLIMI, IPGWY, IPS, VXWSLAN and EROUTE GPLs are not supported in Release 46.0.

3.63 Hardware Maintenance Phase for EAGLE EDCM cards used for SIGTRAN (Release 45.0)

EDCM cards (Part Number 870-2372-xx) are not supported in Release 45.0 for SIGTRAN. The system cannot be upgraded to Release 45.0 if EDCM cards are installed as SIGTRAN cards. The SIGTRAN support performed by these cards is performed by E5-ENET (Part Number 870-2212-xx) and E5-ENET-B (Part Number 870-2971-01) cards.

EDCM cards continue to be supported for EROUTE and STPLAN applications.

As part of this Maintenance phase, the IPGW(x), IPLIM(x), and SS7IPGW GPLs are not supported in Release 45.0.

3.64 Hardware Maintenance Phase for EAGLE EDCM-A cards (Release 46.0)

EAGLE EDCM-A cards (870-2508-xx) are not supported in Release 46.0. The system cannot be upgraded to Release 46.0 if EDCM-A cards are installed. The functionality performed by the EDCM-A cards is performed by E5-ENET (Part Number 870-2212-xx) and E5-ENET-B (Part Number 870-2971-xx) cards.

As part of this Maintenance phase, the BPDCM, BPDCM2, IPLIM, IPLIMI, IPGWY, IPS, VXWSLAN and EROUTE GPLs are not supported in Release 46.0.

3.65 Hardware Maintenance Phase for EAGLE HIPR Cards (Release 46.1)

EAGLE HIPR cards (870-2574-xx) are not supported in Release 46.1. The system cannot be upgraded to Release 46.1 if HIPR cards are installed. The functionality performed by the HIPR cards is performed by the HIPR2 (Part Number 870-2872-xx) card.

As part of this Maintenance phase, the HIPR GPL is not supported in Release 46.1.

3.66 Hardware Maintenance Phase for EAGLE HMUX cards (Release 46.0)

EAGLE HMUX cards (870-1965-xx) are not supported in Release 46.0. The system cannot be upgraded to Release 46.0 if HMUX cards are installed. The functionality performed by the HMUX cards is performed by HIPR (Part Number 870-2574-xx) and HIPR2 (Part Number 870-2872-xx) cards.

As part of this Maintenance phase, the BPHMUX GPL is not supported in Release 46.0.

3.67 Hardware Maintenance Phase for EAGLE IPSM cards (Release 45.0)

DSM-1G cards (Part Number 870-2371-xx) are not supported in Release 45.0. The system cannot be upgraded to Release 45.0 if DSM-1G cards are installed.

The functionality performed by the DSM-1G cards is performed by E5-IPSM (Part Number 870-2877-xx) and E5-ENET-B (Part Number 870-2971-01) cards.

As part of this Hardware Maintenance Phase, the IPS GPL is not supported in Release 45.0.

3.68 Hardware Maintenance Phase for EAGLE MCPM cards (Release 46.0)

EAGLE MCPM cards (870-2372-03/870-2372-07/870-2372-09/870-2372-14/870-2372-15) are not supported in Release 46.0. The system cannot be upgraded to Release 46.0 if MCPM cards are installed. The functionality performed by the MCPM cards is performed by the E5-MCPM-B (Part Number 870-3089-xx) card.

As part of this Maintenance phase, the BPDCM, BPDCM2 and MCP GPLs are not supported in Release 46.0.

3.69 Hardware Maintenance Phase for EAGLE MPL cards (Release 46.0)

EAGLE MPL cards (870-2061-xx) are not supported in Release 46.0. The system cannot be upgraded to Release 46.0 if MPL cards are installed. The functionality performed by the MPL cards is performed by E5-E1T1 (Part Number 870-1873-xx) and E5-E1T1-B (Part Number 870-2970-xx) cards.

As part of this Maintenance phase, the BPMPL, BPMPLT and SS7ML GPLs are not supported in Release 46.0.

3.70 Hardware Maintenance Phase for HC-MIM Card (Release 46.6)

HC-MIM cards (870-2671-xx) are not supported in Release 46.6. HC-MIM cards must be removed and replaced by the E5-E1T1-B (P/N 870-2970-xx) card if upgrading from Release 46.3, or the E5-E1T1-B or SLIC (P/N 7094646) card if upgrading from Release 46.5. The functionality of the HC-MIM card is performed by the E5-E1T1-B or SLIC card.

3.71 Hardware Maintenance Phase for OAM cards (TDM, GPSSM-II, MDAL) (Release 45.0)

As of EAGLE 5 Release 45.0, the OAM cards, MDAL (870-0773-xx), GPSSM-II (870-2360-xx), and TDM (870-0774-xx), are not supported. The OAM cards must be replaced with E5-OAM cards to install or upgrade to EAGLE 5 Release 45.0.

The OAM cards are replaced by the E5-OAM cards: E5-MDAL (870-2900-xx) and E5-MASP (870-2903-xx). The MDAL (870-0773-xx) card is replaced by the E5-MDAL (870-2900-xx). The GPSSM-II (870-2360-xx), and TDM (870-0774-xx) cards are replaced by the E5-MASP (870-2903-xx) assembly, which consists of two cards physically connected into one dual slot assembly.

3.72 Hardware Maintenance Phase for EAGLE TSM cards used for Gateway Screening (Release 45.0)

TSM cards (Part Numbers 870-1289-xx, 870-1290-xx, 870-1291-xx, and 870-1292-xx) are not supported in Release 45.0. The system cannot be upgraded to Release 45.0 if these TSM cards are installed.

The functionality performed by these cards is performed by E5-TSM (Part Number 870-2943-xx) cards and the E5-OAM.

As part of this Hardware Maintenance phase, the GLS and IMT GPLs are not supported in Release 45.0.

3.73 Hex Digit Support for GTT (Release 35.3)

Description

The Hex Digit Support for GTT feature enables the EAGLE® 5 ISS to process both ANSI and ITU Message Signaling Units (MSUs) that contain either decimal or hexadecimal Global Title digits (0-9, a-f, A-F) in the Called Party Address (CdPA) field.

When the Hex Digit Support for GTT feature is enabled and turned on, any of the following three scenarios are possible:

- Incoming MSUs whose digits equal 10 are matched to a global title translation that contains a single GTT table entry of GTA=10.
- Incoming MSUs whose digits equal 20, 21, 22, 23, 24, 25, 26, 27, 28, 29, 30 are matched to GTT table entries with a range of GTA=20 and EGTA=30.

- Incoming MSUs whose **hexadecimal** digits equal **2A, 2B, 2C, 2D, 2E, 2F** are matched to GTT table entries with a hexadecimal range of GTA=20 and EGTA=30.

If desired, the user can then split the hexadecimal range into three separate GTT table entries and specify translation data for hexadecimal digits as follows:

Table 3-9 Translation Data for Hexadecimal Digits

GTA=20	EGTA=29	with existing translation data
GTA=2A	EGTA=F	with user specified translation data
GTA=30		with existing translation data

Before the Hex Digit Support for GTT can be enabled and turned on, the GTT feature must be turned on, and all Translation Services Module (TSM) cards in the system, if installed, must be replaced with Database Services Module (DSM) cards.

When enabled and turned on, the Hex Digit Support for GTT feature enhances the functionality of the following features:

- **ANSI-ITU-China SCCP Conversion**
When the Hex Digit Support for GTT and the ANSI-ITU-China SCCP Conversion features are enabled and turned ON, the values specified for the **npds** and **nsds** parameters can be either decimal digits (**0-9**) or hexadecimal digits (**0-9, a-f, A-F**).
- **Enhanced Global Title Translation (EGTT)**
When the Hex Digit Support for GTT and the EGTT features are enabled and turned ON, the values specified for the **gta**, **egta** parameters in the `gta` command, can be either decimal digits (**0-9**) or hexadecimal digits (**0-9, a-f, A-F**).
- **Global Title Translation (GTT)**
When the Hex Digit Support for GTT and the GTT features are enabled and turned ON, the values specified for the **gta** and **egta** parameters in the `gtt` commands, can be either decimal digits (**0-9**) or hexadecimal digits (**0-9, a-f, A-F**).
- **Modified Global Title Translation (MGTT)**
When the Hex Digit Support for GTT and the MGTT features are enabled and turned ON, the values specified for the **npds**, and **nsds** parameters in the `gta/gtt` commands, can be either decimal digits (**0-9**) or hexadecimal digits (**0-9, a-f, A-F**).
- **Origin-based SCCP Routing (OBSR)**
When the Hex Digit Support for GTT feature and the OBSR features are enabled and turned ON, the values specified for the **cdpa gta/egta** and **cgpa gta/egta** parameters can be either decimal digits (**0-9**) or hexadecimal digits (**0-9, a-f, A-F**).

For more information about how to configure the EAGLE 5 ISS and its database to implement the above listed features, refer to the *Database Administration Manual – Global Title Translation* for this release.

Hardware Requirements

No new hardware is required to support this feature. However, before the Hex Digit Support for GTT feature can be enabled and turned on, all Translation Services Module (TSM) cards in the system, if installed, must be replaced with Database Services Module (DSM) or later revision card running the VSCCP GPL.

 **Note:**

This feature is supported on both 1 GB and 4 GB DSM/VSCCP cards.

See “Appendix B. Hardware Baseline” for the hardware baseline of this release.

Limitations

- **Command length:**
A limitation of the EAGLE 5 ISS is a command length of 150 characters per entry. In some cases, a single `ent/chg-gta/gtt` command entry may not fit on a single line, especially for range entries with MGTT parameters. If an `ent-gta/gtt` command entry does not fit on one line, try running the command specifying less parameters, and then run `chg-gta/gtt` command(s) to modify the translation with the desired parameters. If the `chg-gta/gtt` command entry does not fit on one line, break the command into multiple commands.

 **Caution:**

Breaking lengthy commands must be done with care to ensure that the commands remain syntactically and semantically correct.

- `chg-gws-redirect/ent-gws-redirect/rtrv-gws-redirect`
Hexadecimal digits cannot be specified for the global title address (**gta**) parameter for the `chg-gws-redirect` and `ent-gws-redirect` commands.
Gateway Screening Redirect Commands
- When the Hex Digit Support for GTT and GMS features are enabled and turned ON, the GMS feature **cannot** process incoming MSUs that contain hexadecimal digits. The GMS feature currently supports **only decimal digits** for CGPA.

 **Note:**

The Enhanced GSM Map Screening (EGMS) feature can process incoming MSUs that contain either decimal or hexadecimal digits regardless of whether the Hex Digit Support for GTT feature is enabled and on or not.

GSM Map Screening (GMS) and Enhanced GSM Map Screening (EGMS)

- Hexadecimal digits are **not supported** by SEAS as values for the global title address (**gta**) parameter.

Signaling Engineering and Administration System (SEAS) Commands

3.74 High Capacity Multi-Channel Interface Module (HC MIM) (Releases 33.0 34.0)

Description

The High Capacity Multi-Channel Interface Module (HC-MIM) provides access to 8 E1 or T1 ports residing on backplane connectors A and B. Each port or data stream consists of 24 T1 DS0 channels or 31 E1 channels assigned in a time-division multiplex (TDM) manner. Each channel occupies a unique timeslot in the data stream. Up to 64 signaling links can be assigned to an HC-MIM card.

The HC-MIM card increases the signaling link density in the EAGLE 5 ISS. Because the EAGLE 5 ISS supports a finite number of link interface cards, increasing system capacity or reducing system footprint requires increasing the link density per card. Using fewer cards for a given system capacity yields lower per-link cost.

Configurable temperature alarm thresholds indicate when HC-MIM cards are approaching a temperature that could damage the cards.

64 Link HC-MIM Support

The HC-MIM card operates 8 E1 or 8 T1 port interfaces, with a maximum of 64 signaling links provisioned among the 8 E1 or 8 T1 ports. The HC-MIM card is compatible with existing 2-port E1 cards and E1/T1 MIM cards in the EAGLE 5 ISS shelf for ease in upgrading a live system.

EAGLE 5 ISS software has been modified as follows to support the HC-MIM card:

- All Card, Diagnostic, and Link/Route commands support 8 E1 or 8 T1 ports and up to 64 signaling links per HC-MIM card.
- All Card, Diagnostic, and Link/Route commands support 8 E1 or 8 T1 ports and up to 64 signaling links per HC-MIM card.
- New commands `rept-stat-e1` and `rept-stat-t1` report the status of all E1/T1 links.
- The E1 and T1 commands support the new channel bridging function. On a HC-MIM card, E1 or T1 ports 1, 3, 5, and 7 (master ports) can be independently channel bridged with their adjacent even-numbered (slave) E1 or T1 ports 2, 4, 6, and 8 to allow non-signaling data pass-through.
- The standard alarms have been extended for the additional E1/T1 ports.
- Alarms for the additional E1/T1 ports can be inhibited.
- For links that are assigned HC-MIM cards and E1/T1 MIM cards that are used as T1 cards, the transmission rate can be either 56 Kbps or 64 Kbps.

Multiple LFS

Multiple LFS tests are supported for HC-MIM cards that are used as T1 cards.

LFS (Link Fault Sectionalization) tests are initiated by the EAGLE 5 ISS or other remote network elements. LFS manual, latching or non-latching tests are used to test the functionality of the link from the EAGLE 5 ISS through multiple channel banks to a remote Network Element. LFS can be run on either SS7ANSI and CCS7ITU Application Class (`appl=`) cards. LFS is not supported on E1 cards.

“Manual LFS test” refers to the process of creating a loopback on a signaling link activated by manually enabling the far end for reception and transmission of LFS loopback data. Once the loopback is established, it must be removed by manually disabling LFS on the far end of the signaling link.

“Latching LFS test” and “non-latching LFS test” refers to the process of creating a loopback on a signaling link activated by the transmission of a sequence of pre-defined control codes. Once the loopback is established, it can be removed only by another set of pre-defined control codes.

Latching loopback is activated by the following method:

1. The transmission of a predefined set of Loopback commands. The signaling link test proceeds to step 2 after receiving the command from software to begin sending loopback data.
2. Test data transmitted continuously until a pre-defined loopback code is received to halt transmission.
The latching loopback on the far end will stop only if the correct command is received from the initiator. Test data transmitted continuously until a pre-defined loopback code is received to halt transmission.

Non-latching loopback is activated by the following method:

1. The transmission of a minimum of 40 bytes of loopback code in multiples of 40 bytes, transmitted continuously. The signaling link test proceeds to step 2 after receiving the command from software to begin sending loopback data.
2. Alternating loopback code and test data is transmitted continuously until a message is received to halt transmission.
The non-latching loopback test is dropped if every other byte transmitted is not a loopback code.

The EAGLE 5 ISS supports 1024 simultaneously-running system tests.

The EAGLE 5 ISS supports a maximum of 32 remote link elements per SS7 link.

An HC-MIM card that is used as a T1 card supports as many simultaneous tests as there are provisioned links on that card.

Hardware Requirements

The hardware requirements are as follows:

- HC-MIM card
- HIPR cards in each shelf that contains one or more HC-MIM cards
- Fan Assembly for each shelf that contains HC-MIM cards
- Air Management card in each empty slot in a shelf that contains HC-MIM cards
- Fuse and Alarm panel (requires 60 Amp feed)

The HC-MIM card is a dual-slot card that is inserted into an odd-even pair of slots. An HC-MIM card will not go onto the IMT bus if it is inserted into an even-odd pair of slots.

Any shelf that contains one or more HC-MIM cards must include HIPR on both the A and B IMT buses. The shelf must have a fan assembly, and the fan feature bit must be turned on (see the `chg-feat:fan=on` command). If these conditions are not met, any HC-MIM cards installed in the shelf will not go onto the IMT bus.

Limitations

The limitations of the HC-MIM card in the system are as follows:

- The HC-MIM will not support channel cards because it uses all connections on the backplane.
- The HC-MIM does not support CAS on an E1 interface.
- The HC-MIM card is a dual-slot card that is inserted into an odd-even pair of slots. An HC-MIM card will not go onto the IMT bus if it is inserted into an even-odd pair of slots.
- The HC-MIM card can be provisioned as either an LIME1 card type or an LIMT1 card type. An HC-MIM card cannot go onto the IMT bus if HIPR cards are not equipped in the shelf where the HC-MIM card resides.
- The HC-MIM card used as a T1 card supports manually initiated Link Fault Sectionalization (LFS) tests, requiring a craftsman.
- The final LFS test results are displayed only once, upon test completion.
- There is no notification to the remote network element of Link Fault Sectionalization test initiation or test results.
- LFS test duration is specified in terms of hours, minutes and seconds (hh:mm:ss), and at most 24 hours can be specified.
- The Fuse and Alarm panel requires a 60 Amp feed.

3.75 High Speed IMT Packet Router (HIPR) (Releases 33.0 34.0)

Description

The High Speed IMT Packet Router (HIPR) acts as a gateway between the intra-shelf IMT bus, running at 125 Mbps, and the inter-shelf ring operating at 1.0625 Gbps. The inter-shelf ring is used to connect the shelves together in the EAGLE 5 ISS. A HIPR card installs into the slot that was used by the HMUX card. HIPR cards must replace HMUX cards in shelves that contain HC-MIM cards.

Hourly Report

A HIPR card reports statistics on each of its 16 ports (one port per card slot in the shelf), the high-speed inter-shelf ring, and the UART. For the hourly report, the HIPR card reports the low speed statistics as an aggregate number. The HIPR statistics and the HMUX statistics are different. The rept-imt-info command displays HIPR and HMUX statistics.

Hardware Requirements

HIPR cards can replace HMUX cards in EAGLE 5 ISS shelves. HIPR cards are required in each shelf that contains one or more HC-MIM cards.

Limitations

The accuracy of statistics collected, maintained, and reported by HIPR in the HEM task are limited by the sample rate of the statistics. There are no count values

associated with the sampling of the number of times a particular (recoverable) error has occurred since the last (500mS) sampling period, but simply that one or more of a particular error condition has been detected. Subsequently, a count value is incremented by one. This affects the granularity of the error counts, but not their usefulness in diagnosing IMT problems. An initial sample rate of 500mS has been chosen to minimize the number of accesses by the StrongARM processor to the FPGA via the SlowPort Bus. This is because each access via the SlowPort bus to the FPGA blocks the microengines' access to SRAM, because the SRAM and SlowPort are shared buses.

3.76 High-speed IMT Packet Router (HIPR2) (Release 42.0)

The HIPR2 card (Part Number 870-2872-01) supports enhanced capabilities in existing EAGLE 5 ISS shelves by increasing system throughput. The HIPR2 card allows the IMT inter-shelf bus to operate at 2.5 Gbps.

To operate at the 2.5 Gbps rate, all of the cards in the system must be HIPR2 cards, and the HIPR2 High Rate Mode feature (Part Number 893-0201-01) must be turned on. If this feature is not turned on, then the original throughput rate of 1 Gbps is used even if HIPR2 cards are used.

Note:

When the HIPR2 High Rate Mode feature is turned on or off, an IMT Rate Change Sequence occurs. Certain commands cannot be performed during this sequence. Refer to *Commands Manual* for more information.

Traffic between EAGLE 5 ISS cards on the same shelf is switched directly to the destination slot and does not transit to any other cards in the shelf. The HIPR2 card provides switched 125 Mbps IMT interface to each slot in a shelf.

The HIPR2 card supports a new **hipr2** GPL and **hipr2** application.

Note:

Support for HIPR2 card 870-2872-02 was also introduced in EAGLE Release 42.0.

3.76.1 Feature Control Requirements

- The HIPR2 High Rate Mode feature must be enabled and turned on (FAK for Part Number 893-0201-01) for the system to operate at 2.5 Gbps.
- A temporary FAK cannot be used to enable the feature.
- The feature can be turned on and off.

3.76.2 Hardware Requirements

- HIPR2 cards must be installed in all MUX locations in the EAGLE 5 ISS before the HIPR2 High Rate Mode feature can be turned on.

- A high-speed fiber-channel cable (Part Number 830-1344-xx) must be used to allow the HIPR2 cards to run at 2.5 Gbps. This cable is included in the 890-0230-xx and 890-0231-xx cable kits.
- HIPR2 (Part Number 870-2872-01) is fully NEBS compliant. However, if ambient temperatures above 40° C are likely, Eagle Fan Trays (Part Number 890-0001-04) are recommended to ensure proper airflow to the upper HIPR2 cards in those shelves.

3.77 High Speed Master Timing (Release 26.0)

Overview

The High-Speed (**HS**) Master Timing feature offers a new mode of operation that allows a high-speed capable (**T1** or **E1** rate) **Link** Interface Module (**LIM**) installed in an **EAGLE STP** to receive its transit timing reference directly from an external high-speed master clock source, instead of slaving to the timing information contained in the received data. The timing information is encoded into the T1 or E1 transmitted data stream to synchronize downstream equipment.

Note:

The EAGLE terminal output screens refer to the composite clocks as Building Integrated Timing Source (**BITS**) clocks. In this document references to BITS and composite clocks are used interchangeably.

The HS master clock signals are encoded with the data stream originated or received by the EAGLE STP, thus assuring synchronized data transmission. The HS Master Timing feature is integrated into the programmable logic contents on the **Terminal Disk Module (TDM)** card and the **PROM** of the **MAS** communications application processor (**MCAP**) card. The HS Master Timing feature requires updating these cards and the redundant **TDM/MCAP** card pair to specified release levels. Since a **TDM/MCAP** card pair makes up the **Maintenance and Administration Subsystem Processor (MASP)**, this card pair is also referred to as **MASP** in this manual.

The composite clock cables connect the site's composite (BITS) clocks with the EAGLE STP control shelf. Implementation of the HS Master Timing feature requires the replacement of both composite clock cables with two new HS master clock cables (**RS422** compatible) on control shelf backplane (P/N 850-0330-05/06 and later). The following figure illustrates HS master and composite clock cabling with control shelf backplane (P/N 850-0330-05/06 or later).

Figure 3-6 HS Master Timing Concept Control Shelf Backplane (P/N 850-0330-05/06 or later)

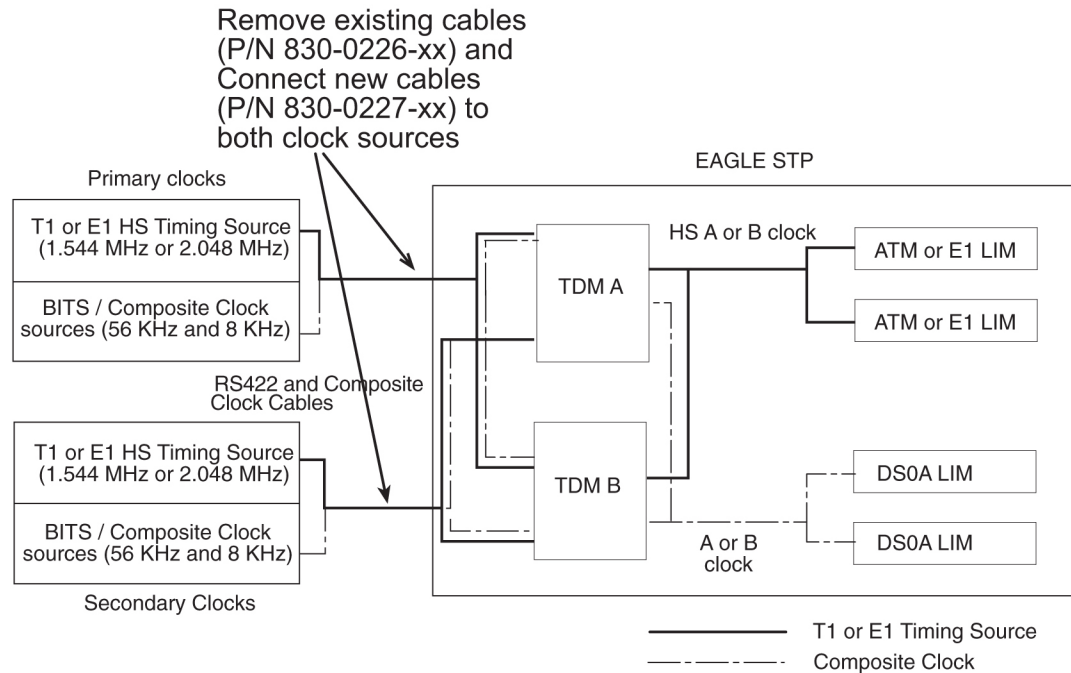

Implementation of the HS Master Timing feature requires the addition of two HS master clock cables on control shelf backplane (P/N 850-0330-03/04). The following figure illustrates the HS master timing concept for control shelves with backplane (P/N 850-0330-03/04).

Only ATM LIM cards or E1 LIM cards can be configured or reconfigured for the HS Master Timing feature. Once the baseline hardware requirements for the HS Master Timing feature have been met:

- physically install an ATM card, add the card to the system database, and enable it for the HS Master Timing feature (`ent-slk:atmtsel=external`); or
- physically install an E1 LIM card, add the card to the system database, and enable it for the HS Master Timing feature (`ent-e1:e1tsel=internal`).

Reconfigure any existing ATM LIM card or E1 LIM cards to use the HS Master Timing feature. LIM cards that will continue using the composite clock will not require any changes to the card provisioning.

Figure 3-7 HS Master Timing Concept using Control Shelf Backplane (P/N 850-0330-03/04)

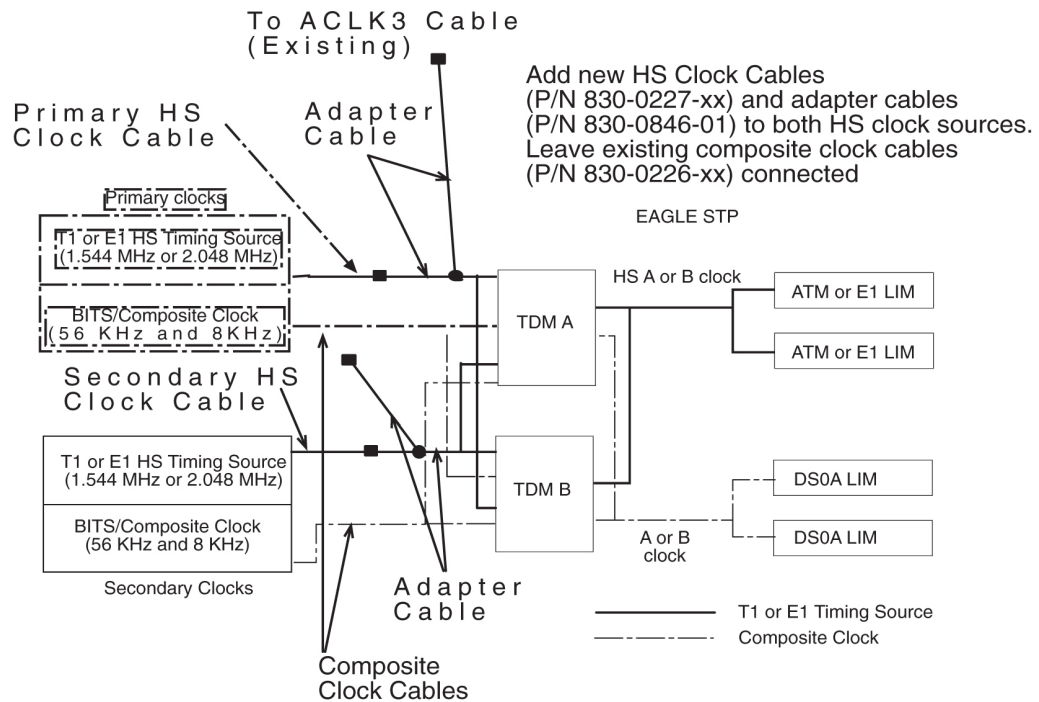

Feature Concept

Digital networks require accurate timing sources to maintain the integrity of data transmission. Utilizing high-speed clocking provides improved data synchronization capabilities.

Master Clock

The master clock is the source of timing signals and uses these signals for network synchronization. For the HS Master Timing feature, the site's master clock can be a T1 (1.544 MHz) or E1 (2.048 MHz) rate clock source on **RS422** compatible cable.

System Clocks

The EAGLE STP system clock is derived from the site's master clock source, which is often the site's holdover clock. The EAGLE STP typically connects to the site's composite clocks signals, a primary and secondary clock signal for redundancy. The EAGLE STP's internal composite clock distributes the signals to all cards at a combined rate of 56 kHz and 8 kHz.

By enabling the HS Master Timing feature on high-speed capable ATM LIM cards or E1 LIM cards, the cards can take their high-speed clock reference directly from the external HS master clock source, such as the master clock source available at the site.

The external HS clock source provides the EAGLE STP with a second system clock. The EAGLE STP can now connect to

- two 64 kHz composite clocks (primary and secondary clocks) and
- two T1 (1.544 MHz) or E1 (2.048 MHz) rate clock sources (primary and secondary clocks).

With both system clocks, the EAGLE STP will distribute the HS clock signals with the composite clock signals. The EAGLE STP distributes the clock signals to each frame. All shelves, both extension shelves and control shelves, provide *clock in* and *clock out* connections. The EAGLE STP connects to its primary and secondary system clocks through connectors on the backplane of the control shelf. The backplane connectors are labeled *Primary BITS* and *Secondary BITS*. Both primary and secondary clock signals are sent to each TDM card. The TDM cards select between the primary and secondary signals to provide system clocks (A clocks and B clocks) to the rest of the EAGLE. ATM LIM cards use a T1 HS master clock source, E1 LIM cards use an E1 HS master clock source, and DS0A LIMs use the internal composite clock sources. Each ATM or E1 LIM card selects between the HS master A or B clock source. Each DS0A LIM selects between the A or B composite clock source. The following figure shows system clock use by LIM cards.



Note:

An STP can be configured for either a T1 (1.544 MHz) or E1 (2.048 MHz) HS master clock source, but not both.

Figure 3-8 System Clocks

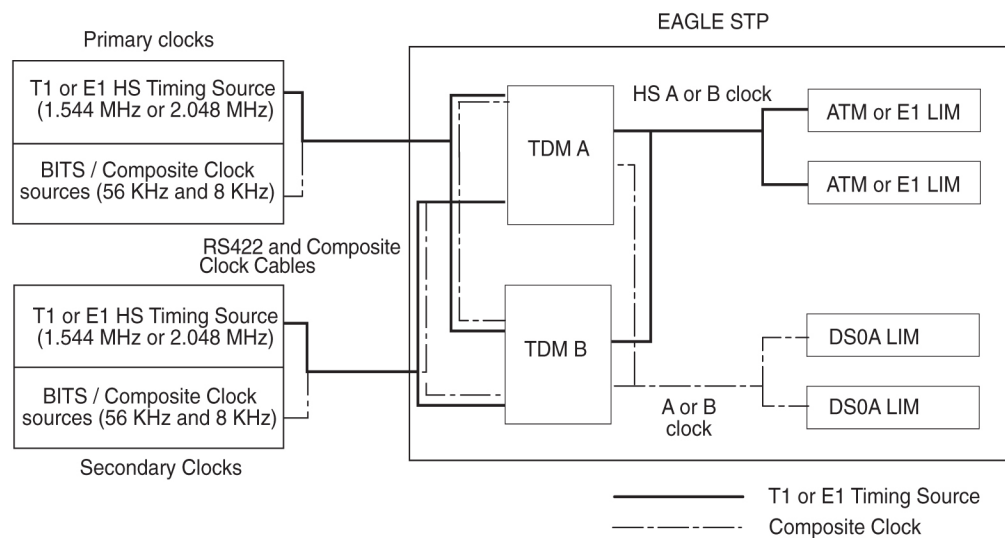

TDM Card

EAGLE operation is controlled by Maintenance and Administration Subsystem (MAS) cards. MAS cards consist of two MAS communications application processor (MCAP) cards, two Terminal Disk Module (TDM) cards, and one Maintenance Disk and Alarm (MDAL) card. The TDM card contains the fixed disk drive, the terminal processor for 16 serial I/O ports, and an interface to the MDAL card. The MDAL card contains the removable cartridge drive and alarm logic. Prior to the implementation of the HS Master Timing feature, the TDM card directly supported all of the EAGLE timing functions by distributing composite clock signals to the system.

Internal Clock Defaults

The TDM card generates an internal composite clock when no external composite clock is present on the primary or secondary inputs. If no T1 or E1 high speed clock, is provided, the high-speed system clocks to the LIM cards become inactive.

The TDM card can independently select between primary and secondary high-speed (HS) master clock and primary and secondary composite clock (BITS clock), and switches automatically to the idle clock when one of the active clocks fail.

The following table lists the various clocking modes resulting from the clock inputs received by the TDM card and the resulting clock output to the LIM card.

Table 3-10 Clock Signal Modes

Site Clock Availability (Input to TDM cards)	Clock Distribution to EAGLE (Possible TDMCard Outputs)	Clock Selection by LIM
Primary and/or Secondary HS Master Clock Available	TDM A and B HS CLK available	Software selects A or B HS clock
	TDM A HS CLK unavailable	HW selects B HS clock
	TDM B HS CLK unavailable	HW selects A HS clock
	TDM A and B HS CLK unavailable	No HS clocks available
Primary and Secondary HS Master Clock Unavailable	TDM A and B HS CLK unavailable	No HS clocks available
Primary and/or Secondary BITS Clock Available	TDM A and B BITSCLK available	Software selects A or B composite clock
	TDM A BITSCLK unavailable	HW selects B composite clock
	TDM B BITSCLK unavailable	HW selects A composite clock
	TDM A and B BITSCLK unavailable	No clocks available (runs on internal)
Primary and Secondary BITS Clock Unavailable	TDM A and B BITSCLK unavailable	No clocks available (runs on internal)

Note: "Unavailable" means the clock is not valid or not present.

For a timing source, ATM LIM cards or E1 LIM cards use the system clock required by their card type and the **Generic Program Load (GPL)** installed on the card. For detailed information on configuring ATM or E1 cards, refer to *Database Administration Manual - SS7* of your current documentation suite.

MCAP Card

To support the HS Master Timing feature, a new Programmable Read-Only Memory (PROM) is required for the MCAP card (containing a new Clock LCA bit file in the IMT quadrant of the PROM), new interprocessor message transport (IMT) GPL for LIM cards (SS7ANSI, CCS7ITU, SS7GX25, STPLAN, GLS, SCCP), BPHCAP GPL for High Capacity Application Processor (HCAP) (ATMANSI) cards, BPDCM GPL for DCM cards, and a new OAM GPL.

Administration

The HS Master Timing feature allows a high-speed capable (T1 or E1 rate) Link Interface Module (LIM) installed in an EAGLE STP to receive its transit timing

reference directly from an external high-speed master clock source, instead of slaving to the timing information contained in the received data. The high-speed master timing feature is enabled through the provisioning of at least one high speed link (ATM or E1 LIM card). At that time, the GPL required for the feature is downloaded from the MCAP card to the TDM card. For provisioning high speed links, the following commands have been changed to support master timing:

- REPT-STAT-CARD:MODE=FULL
- REPT-STAT-CLK
- ENT-SLK
- RTRV-SLK
- ENT-E1
- CHG-E1

Refer to *Commands Manual* for current usage information.

3.78 High-Speed Multiplexer (HMUX) (Release 27.2)

The **High-Speed Multiplexer (HMUX)** supports the **EAGLE** Large System feature, which expands the number of links supported by the **EAGLE STP**. The **HMUX** enhances the **IMT** bus by introducing a new 1Gb/sec inter-shelf bus bandwidth. The intra-shelf bus data rate will remain the same at 125Mb/sec.

The **HMUX** feature also enhances **IMT** performance by transmitting data between shelves only when it is necessary. Traffic between **EAGLE** cards on the same shelf will be allowed to remain on the shelf **IMT**, and will not be required to transmit between shelves. Traffic between shelves will not be required to pass onto an intra-shelf **IMT** bus if it is not necessary.

Introduction of the **HMUX** transforms each **EAGLE IMT** bus from a single ring topology running at 125Mbps, to a central primary ring operating at 1Gb/sec, with a maximum of sixteen secondary rings running at 125Mbps. Refer to [Figure 3-7](#).

Figure 3-9 HMUX Ring Topology

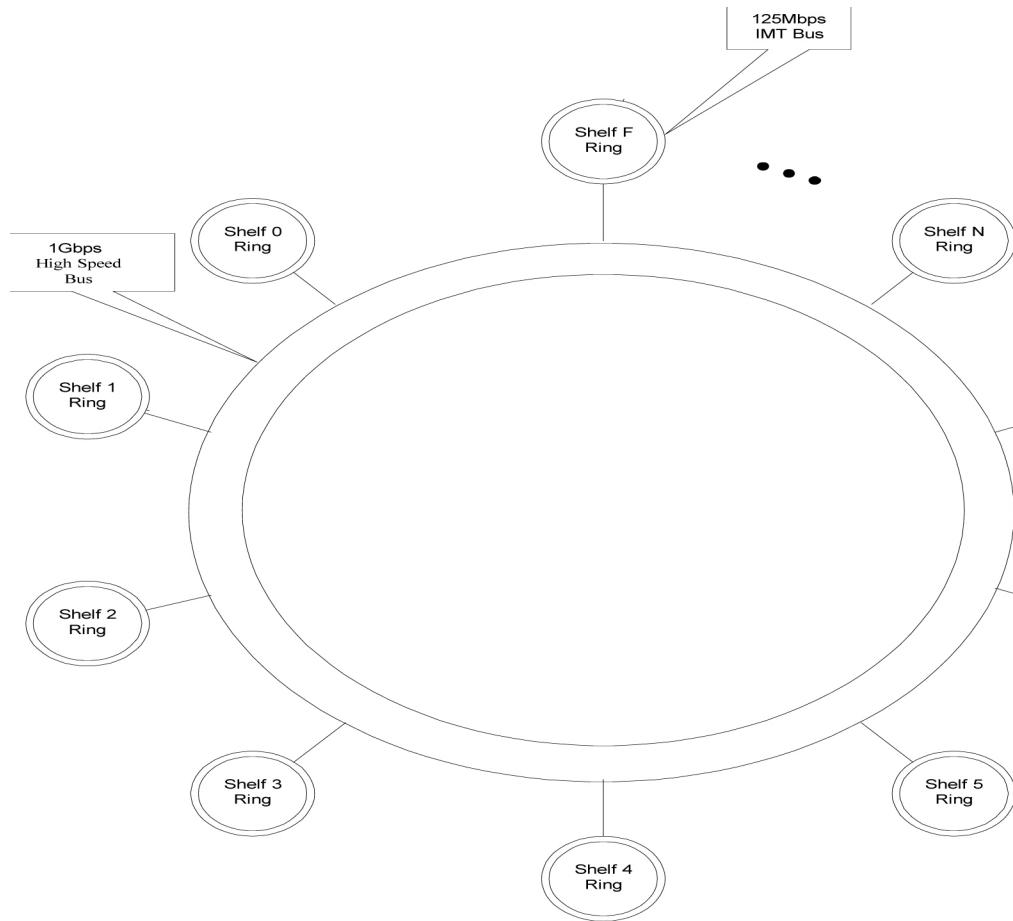

Hardware Requirements

Support of this feature requires the following hardware:

Table 3-11 Hardware Required for High-Speed Multiplexer

Hardware	Assembly Part Number
HMUX	870-1965-01 or later
TDM	870-0774-10 or later
Control Shelf and	870-2321-01 or later
Adapter cable	830-0857-01
MCAP-256 w/ special PROM with FPGA logic files for new ECAM CLOCK LCA	870-1307-07

Upgrade Considerations

The following **EAGLE** tables will be modified/converted/created as part of the upgrade for this feature:

- **STPOPTS.TBL/BKP**

- (T)**BPHMUX.ELF**

3.79 Holdover BITS Clock Support (Release 21.0)

The holdover **BITS** clock is an optional external device that provides clock input to the **EAGLE** for a specified period of time when the **BITS** clock fails. The holdover **BITS** clock resides in the **OAP** frame of the **EAGLE**. This feature adds additional outputs on the control shelf to control the holdover **BITS** clock. The holdover **BITS** clock is a Telecom Solutions Digital Clock Distributor, **DCD-523**. The holdover **BITS** clock maintains clock synchronization for 15 seconds. This meets the Bellcore requirement as specified in **TR-NWT-001244**. When used with the **EAGLE**, the holdover **BITS** clock contains the following cards:

- 2 **CI** cards - clock inputs A and B
- 2 **ST3E** cards - clocks A and B
- 2 **TOCA** cards in card locations **TO1** and **TO2** - outputs to the **EAGLE**

The outputs of the **TOCA** cards are connected to a wire wrap panel mounted on top of the holdover **BITS** clock. The clock inputs on the **EAGLE** control shelf are connected to the wire wrap panel.

3.80 HomeSMSC Match with Digits Option for Portability Check for Mobile Originated SMS (Release 39.0)

The HomeSMSC Match with Digits Option for Portability Check for Mobile Originated SMS (HomeSMSC Match) enhances the ability of the **EAGLE 5 ISS** to compare the Home Short Message Service Center (**HomeSMSC**) digits in the SCCP CdPA of incoming GSM MAP Mobile Originated Forward Short Messages (**MO_FSM**) to HomeSMSCs that are stored in the database. If the beginning digits of the incoming HomeSMSC matches a stored HomeSMSC, then the HomeSMSCs are considered a match, even if additional digits are attached to the end of the incoming HomeSMSC. If a match is found, then the message is rejected.

3.80.1 Feature Control Requirements

The Portability Check for Mobile Originated SMS feature must be turned on before the HomeSMSC Match option can be provisioned.

3.80.2 Hardware Requirements

There are no additional hardware requirements for this feature.

3.80.3 Limitations

No limitations are associated with this feature.

3.81 Hybrid INP/IDP Relay Service (Release 43.0)

The Hybrid INP/IDP Relay Service feature allows the existing Prepaid IDP Query Relay feature (Part Number 893-0160-01) to send **CONNECT**, **CONTINUE**, or **RELEASECALL** responses based on the RTDB lookup results. This functionality includes the ability to

configure whether the *CutAndPaste* parameter is included in the CONNECT message when the message is sent from the Prepaid IDP Query Relay feature.

The functionality is configured for the Prepaid IDP Query Relay feature using a new INPRTG Service Action, which is applicable to the IDPRCDPN(X) and IDPRCGPN NPP services. Refer to the *Numbering Plan Processor (NPP) Overview* for more information.

The Hybrid INP/IDP Relay Service feature also allows a Service Control Point (SCP) Global Title Address (GTA) to be provisioned based on a Service Key. This functionality is configured using a new SKGTARTG Service Action which is applicable to IDPRCDPN(x) services. This Service Action allows the IDP message to be routed to the provisioned SCP GTA. If the functionality is not configured, then the message is routed to the incoming SCCP Called Party Address (CdPA) GTA.

 **Note:**

If both A-Party Routing and Service Key based GTA routing are configured, then the Service Key based GTA routing takes precedence.

3.81.1 Feature Control Requirements

The Prepaid IDP Query Relay feature must be enabled before the Service Key based GTA routing functionality can be provisioned.

3.82 IAR NP Service Portability (Release 41.1)

Service Portability support for the IAR Number Portability (IAR NP) feature allows the CDPNNP Service Action to use RTDB GRN Entity digits for own-network GSM or IS41 subscribers to populate the Numbering Plan Processor (**NPP**) RN Formatting Action value.

Service Portability functions are applied by the CDPNNP Service Action. The RN Formatting Action value is populated only when NPTYPE Evaluation success criteria are met when Service Portability processing is applied.

3.83 Idle Terminal Port Logout (Release 21.0)

The **EAGLE** keeps track of how long a login session has remained idle. Every minute, the **EAGLE** examines all of the login sessions currently active. Whenever a login session has been idle (idle is defined as no input from the user) for more than the maximum allowable time (provisionable on a per-port basis), the session is ended by forcing an automatic logout.

The **EAGLE** issues a message to the scroll area of all system administrator terminals whenever a logout occurs. A slightly different message is issued when an idle time logout occurs:

```
User xxxxxxxx auto logged out (idle time exceeded) on port yy.
```

where xxxxxxxx is the user **ID** that was logged off and yy is the port that the user **ID** was using before the logoff. In addition to being issued to all system administrator terminals, this same message is sent to the scroll area of the idle terminal that is being logged out.

The idle time logout is designed so that it will not interfere with existing or planned **EAGLE** features that might falsely or undesirably trigger the idle time logout:

- The idle time logout feature is suspended for a port while that port is in the process of transferring a file.
- **SEAS** ports are not affected by idle port logout. **SEAS** ports are unique in that no login is required in order to access the **EAGLE** with a **SEAS** port, and thus there is no login session whose idle time can be monitored.

The maximum idle time value can be configured on a per-port basis; different maximum idle times can be established for each port, using the `tmout` parameter of the `chg-trm` command.

The system administrator is allowed to set a port's idle timeout value to 0. This indicates that a user **ID** may remain idle on the port indefinitely without being automatically logged off due to idle time expiration.

The system default value for the `tmout` parameter is 30 minutes.

The monitoring of a terminal's idle time (`tmout`) and the automatic logout function only applies to terminal types **VT320** (`type=vt320`), **KSR**, (`type=ksr`), and **SCCS** (`type=sccs`). The `tmout` parameter can be specified with other terminal types, but it will have no effect.

During a Kermit file transfer, the idle time monitoring is temporarily suspended and the port's idle time is reset to 0 and does not resume until after the file transfer completes, even though there is no user input from the terminal during the file transfer operation. This prevents a terminal from being automatically logged off immediately after a file transfer completes. For example, if the value of the `tmout` parameter for a terminal is 1 minute and a file transfer is performed that takes 5 minutes. The terminal idle monitor is suspended during the file transfer and does not resume until the file transfer operation completes. Therefore, the terminal is logged off 1 minute after the file transfer completes unless there is additional user input.

The idle port logout occurs even if a port is in the process of executing a command when the idle threshold is exceeded. For example, if the `chg-pid` command is executed and the user never supplies any input to the `Enter Old Password :` prompt, when the terminal's idle time threshold is exceeded, the terminal is logged off and the command that was in progress is aborted.

3.84 IDP A-Party Blacklist (Release 41.1)

The IDP A-Party Blacklist feature enhances the Prepaid IDP Query Relay feature to provide a generic framework to support subscriber blacklisting capability that works with either a query-based or relay-based method. The feature supports the blacklist check on the Calling Party (A-Party or CgPN) number in the IDP CAMEL or INAP message.

The EAGLE receives an IDP query message destined to the EAGLE Point Code or a prepaid IDP message sent to the EAGLE Point Code for translation to prepaid SCP. MSCs are configured with a trigger point to send an IDP message for just post-paid or prepaid subscribers or for all subscribers in the network, depending on the use case for a particular operator.

The EAGLE receives the IDP message and performs the necessary discrimination and pre-processing using the current prepaid IDP Relay functions (SCCP CdPA check, **CgPA** check and Common Screening List SK BCSM filter). The EAGLE decodes the Calling Party Number (from the **CgPN** parameter) from the message. If the subscriber number is blacklisted, the number is entered with a blacklist flag and optional routing number information. If a match is found, EAGLE returns a Connect message with Routing Number (if provisioned). This Routing Number could be a service center number that receives the re-routed call and provides the necessary assistance. If the subscriber is not blacklisted, the IDP message continues normal processing (if it is prepaid IDP message), or a CONTINUE response is generated (if the blacklist query is received).

3.84.1 Feature Control Requirements

- FAK for Part Number 893-0332-01
- The IDP Relay feature (Part Number 893-0160-01) must be turned on before the IDP A-Party Blacklist feature can be enabled.
- The IDP A-Party Blacklist feature cannot be enabled if the Service Portability feature (Part Number 893-0343-01) is enabled.
- A temporary FAK cannot be used to enable the feature.
- The feature cannot be turned off after it is turned on.

3.84.2 Limitations

No limitations are associated with this feature.

3.85 IDP A-Party Blacklist (EPAP 13.0)

The IDP A-Party Blacklist feature for EAGLE 5 ISS enhances the Prepaid IDP Query Relay feature to provide a generic framework to support the subscriber blacklisting capability that works with either a query-based or relay-based method. The feature supports the blacklist check on the Calling Party (A-Party or CgPN) number in the Initial Detection Point (IDP) Customized Applications for Mobile Networks Enhanced Logic (CAMEL) or Intelligent Network Application Protocol (INAP) message.

For EPAP, this feature allows calling and called-party blacklist data to be associated with Directory Numbers (DNs) and DN Blocks that reside in the PDDB and RTDB databases. The blacklist data will be used by the EAGLE to support IDP Queries. If the calling party is associated with a blacklisted flag and a Generic Routing Number (GRN), then a connect message is sent back to the switch along with the GRN. The GRN is then used to re-route the call to a predetermined destination. Currently only Calling party is used by the EAGLE 5 ISS.

Hardware Requirements

Service Module cards (DSM cards with at least 4G of memory, E5-SM4G cards, or a mixture of both).

Limitations

The IDPR Relay feature must be enabled and turned on before any of the new IDP enhancements can be enabled.

IDP A-Party Blacklist feature only processes IDP messages. It will not process IDPSMS messages, since the expected response is not known.

1. Prepaid subscribers can have either prepaid types or associated portability status, but not both.
2. The customer cannot have different SCP servers for SMS and IDPR handling for the same subscriber.
3. Care must be taken when performing subscriber provisioning to make sure that the PT type does not conflict with any other EAGLE 5 ISS feature solutions.
4. To select an IDPRCDPN NPP service rule set, the CdPN number of digits in the received IDP/IDPSMS message must be non-zero.
5. Network conversion between the incoming msu-type and a connect/continue response is not supported.
6. Blacklist feature changes will support a Connect/Continue response only for InitialDP messages (Opcode 0). IDPSMS/IDPGPRS messages will not be checked by the Blacklist feature, but this does not affect processing by any other IDPR feature components.
7. Network conversion between the msu-type of the incoming IDP/IDPSMS message and the associated prepaid PPSOPTS:PC msu-type is only supported between ITU-I/ITU-N network types.
8. If both IDPS and IDP SK Routing feature functionality is required on a NODE for the same Service Key and EventType BCSM parameters, then the srtsel should be different for both. IDPS encodes a "continue" when a match is made in the skbcsm list for SK-BCSM parameters of incoming messages, but IDPR SK Routing will attempt to route the message to the defined prepaid server.

PDBI Changes

PDBI supports the provisioning and retrieval of the Calling and Called Blacklist data for DNS by adding two new optional parameters:

- Calling Party Blacklist (cgb1)
- Called Party Blacklist (cdb1)

These parameters can have the values "no" (default) or "yes".

The updated commands are:

- ent_sub
- rtrv_sub
- upd_sub

Example: If the Calling Party Blacklist is selected as 'no' and the Called Party Blacklist is selected as 'yes', PDBI command will be as follows:

```
ent_sub(iid 3, bdn 123456, edn 654321, pt 12, cdb1 yes, asd 545454, rn 234567)
```

Feature Control Requirements

See the *EAGLE 5 ISS Release 41.1 Feature Notice*.

3.86 IDP A-Party Routing (Release 41.1)

The IDP A-Party Routing feature allows routing for IDP or IDPSMS messages to be performed using the A-Party Calling Party Number (CgPN). This feature provides a routing alternative to the existing SCCP GTA routing. A-Party routing is performed using a new CGPN Service Action and invoking new algorithms during post-NPP processing.

If successful IDP A-Party routing occurs, then an IDP or IDPSMS message is routed to an available Prepaid Server from a list of provisioned servers in the MRNSET or MAPSET load share table. If routing failure occurs, then a UDTs is sent to the originator or the message is discarded.

If all of the required data for IDP A-Party routing is not provisioned, then routing falls through to GTT routing.

Interaction with IDP Service Key Routing feature

If the IDP Service Key Routing (IDP SK Routing) or IDP A-Party Routing feature is turned on, then the system behaves as if the routing provided by that feature was the only routing option.

If both features are turned on, and the A-Party Routing Service Action is provisioned, then both features are considered for processing. The IDP A-Party Routing option is checked first. If IDP A-Party Routing is not attempted, and the IDP SK Routing option is provisioned, then IDP SK Routing is considered.

If IDP A-Party Routing is not attempted, and the IDP SK Routing option is not provisioned, then GTT routing is performed.

Whether A-Party Routing or SK Routing is attempted, once a message attempts to route, the message does not attempt any other routing method, including SCCP GTA/GTT routing. If routing fails, then the attempt is considered an IDPR routing failure, a UDTs is sent, and the message is discarded.

Note:

Post-processing network conversion for IDP A-Party Routing and IDP SK Routing can only be performed for ITU-I or ITU-N network types.

3.86.1 Feature Control Requirements

- FAK for Part Number 893-0333-01
- The IDP Relay feature (Part Number 893-0160-01) must be turned on before the IDP A-Party Routing feature can be enabled.
- A temporary FAK cannot be used to enable the feature.
- The feature cannot be turned on and off.

 **Note:**

The IDP A-Party Routing and the IDP SK Routing features are not dependent or exclusive with each other. The features can be enabled, turned on, and used independently or together.

3.87 IDP Relay Support for CAP v3 IDP-SMS (Release 40.0)

The IDP Relay Support for CAP v3 IDP-SMS feature allows the Prepaid IDP Query Relay (IDP Relay) feature to support CAP v3 IDPSMS messages. The Called Party Number (CdPN) is derived from the Destination Subscriber Number in the message, and an EventTypeSMS field is used instead of BCSM.

For SKBCSM lookup in the CSL table, a hexadecimal value of *0x50* is added to the EventTypeSMS from the MSU before finding a match. SKBCSM lookup is considered successful when the BCSM value provisioned in the CSL table has a value that is equal to *0x50 + incoming EventTypeSMS*.

3.88 IDP Screening for PrePaid (Release 34.3)

Description

The **IDP** Screening for Prepaid feature screens **GT**-routed messages resulting from voice and text calls from a prepaid subscriber to determine whether the subscriber has a "24/7 Call and Text Unlimited" or a "24/7 Text Unlimited" calling plan and then routes the call accordingly.

For a voice or text (short message) call originated by a prepaid subscriber, the serving **MSC** formulates an **INAP IDP** message which is destined for a prepaid engine that checks the subscriber's credit status. The **IDP** Screening for PrePaid feature causes **EAGLE 5 SAS** to intercept the **IDP** message and determine whether the subscriber has one of the calling plans referenced above.

Voice and text calls are identified by a predefined Service **Key**. The value assigned to the Service **Key** is set by an originating **MSC** when the call reaches an Intelligent Network (**IN**) trigger. These values indicate whether the subscriber has the "24/7 Call and Text Unlimited" or "24/7 Text Unlimited" calling plan.

If the subscriber has one of the calling plans, the **EAGLE 5 SAS** determines whether the call is an in-network call (a call from one subscriber to another belonging to the same network). For an in-network call, the **EAGLE 5 SAS** returns an **INAP** Continue message to instruct the **MSC** to bypass the credit check and continue the call. If the call is not an in-network call, **EAGLE 5 SAS** routes the calls to the prepaid engine to have the credit check performed.

If the call originates from a non "24/7 Call and Text Unlimited" or non "24/7 Text Unlimited" prepaid subscriber, the **EAGLE 5 SAS** routes the **IDP** message to its intended destination.

This feature requires a feature access key.

Hardware Requirements

- After the **IDP** Screening for Prepaid feature is turned on, no **TSM SCCP** cards can be provisioned.
- Only **DSM** cards are used with the **IDP** Screening for Prepaid feature.

3.89 IDP Service Key Routing (Release 41.1)

The IDP Service Key Routing (IDP SK Routing) feature allows routing to occur based on the Service Key and EventType BCSM parameters in the incoming IDP or IPDSMS message. IDP SK routing can occur independently or can be used as a fall-through option for the IDP A-Party Routing feature. See [IDP A-Party Routing \(Release 41.1\)](#) for a description of the interaction between the features.

If successful IDP SK routing occurs, then an IDP or IDPSMS message is routed to an available Prepaid Server from a list of provisioned servers in the MRNSET or MAPSET load share table. If routing failure occurs, then a UDTs is sent to the originator or the message is discarded.

If all of the required data for IDP SK routing is not provisioned, then routing falls through to GTT routing.

3.89.1 Feature Control Requirements

- FAK for Part Number 893-0336-01
- The IDP Relay feature (Part Number 893-0160-01) must be turned on before the IDP SK Routing feature can be enabled.
- The feature cannot be enabled with a temporary FAK.
- The feature cannot be turned off after it has been turned on.

Note:

The IDP A-Party Routing and the IDP SK Routing features are not dependent or exclusive with each other. The features can be enabled, turned on, and used independently or together.

3.90 IDPR Intl Normalization (Release 37.10)

The IDPR Intl Normalization feature allows the IDP Relay feature to process INAP/CAP messages containing routing numbers (**RNs**) that have leading zeros and a National Escape Code (**NEC**), which usually has a value of **0**.

If the message has an associated NEC, then the message is received by the EAGLE 5 ISS with the message number in the format `<NEC><DN>`. If the IDPR feature is turned on, then the RN is inserted after the NEC, resulting in a format of `<NEC><RN><DN>`.

If both the NEC and RN have a value of 0, then the signaling control point (**SCP**) interprets the two zeros as an International Escape Code (**IEC**), which is usually **00**, instead of NEC+RN.

The IDPR Intl Normalization feature adds **00** and the Country Code (**CC**) before the RN in the message and reconstructs the Called Party Number (CdPN) in the outgoing INAP/CAP message as `<00><CC><RN><DN>`.

3.90.1 Feature Control Requirements

The IDPR Intl Normalization feature has the following feature control requirements:

- A FAK for part number 893-0226-01
- The Prepaid IDP Query Relay feature must be enabled and turned on before the IDPR Intl Normalization feature can be enabled.
- A temporary FAK cannot be used to enable the feature.
- The feature can be turned on and off.

3.90.2 Hardware Requirements

There are no additional hardware requirements for this feature.

3.90.3 Limitations

When this feature is implemented, the capacity limits for combinations of DN/IMSI will be less than what is supported today.

- Existing limit: {DN, IMSI} = {36M, 60M}, {12M, 82M} and {6M, 90M}
- New limit for EPAP 10.0: {DN, IMSI} = {36M, 52M}, {12M, 75M} and {6M, 82M}

This decrease in capacity is based on high-level engineering design for the feature. Since these combinations are not used in the field, this limitation does not affect any customers.

3.91 IDPR TON Mapping for CdPN BCD Format (Release 44.0)

The IDPR TON mapping feature allows configuration of the mapping that occurs when encoding or decoding the BCD parameter for a Called Party or Calling Party number. The Type of Number (TON) value, Nature of Address Indicator (NAI) value, and the type of mapping used (NAI to TON for encoding or TON to NAI for decoding) can be configured.

3.92 IETF M3UA for “A” Link Connectivity (Release 28.1)

Description

To connect to a variety of **IP** enabled **SCP**'s, the **VXi** Softswitch, or other **IP** enabled network elements, the **EAGLE STP** and **IP⁷** Secure Gateway must use industry standard protocols. In the **IETF** Signaling Transport (**SIGTRAN**) model, **SS7 MTP3-User Adaptation Layer (M3UA)** is a User Adapter layer which resides on top of **SCTP**, necessary for connection to **IP** enabled network elements.

Hardware Requirements

This feature requires a **SSEDCM** (Single Slot Enhanced **DCM**).

3.93 IETF M3UA Support including IETF SUA (IP⁷ Release 5.0)

Description

Although widely accepted throughout the industry, the **TALI** protocol is not a standard adapter layer protocol at this time. To interoperate with various vendors, the adapter layer protocols produced by the **IETF** must be implemented on the Secure Gateway. The concepts defined in the **IETF** drafts will provide a building block for better support of fail-over scenarios that can be implemented in **TALI**.

The **M3UA** Layer is designed to fit the need for signaling protocol delivery from an **SS7** Signaling Gateway (**SG**) to a Media Gateway Controller (**MGC**) or **IP**-resident **Database**. The layer is expected to meet the following criteria:

- Support for the transfer of all **SS7 MTP3**-User Part messages (for example, **ISUP**, **SCCP**, **TUP**, and so forth)
- Support for the seamless operation of **MTP3**-User protocol peers
- Support for the management of **SCTP** transport associations and traffic between a **SG** and one or more **MGCs** or **IP**-resident **Databases**
- Support for **MGC** or **IP**-resident **Database** process fail-over and load-sharing
- Support for the asynchronous reporting of status changes to management.

The **SUA** Layer is designed to fit the need for the delivery of **SCCP**-user messages (**MAP** and **CAP** over **TCAP**, **RANAP**, and so forth) and new third generation network protocol messages over **IP** between two signaling endpoints. Consideration is given for the transport from an **SS7** Signaling Gateway (**SG**) to an **IP** signaling node (such as an **IP**-resident **Database**). This protocol can also support transport of **SCCP**-user messages between two endpoints wholly contained within an **IP** network.

Refer to the *Database Administration Manual Features* for current information on this feature.

New Hardware

Same as **IETF SCTP**.

Upgrade Considerations

Same as **IETF SCTP**.

Limitations

Same as **IETF SCTP**.

3.94 IETF Protocol Update (Release 28.1) (IP⁷ Release 6.0)

Description

Since the introduction of the **IETF** Sigtran protocols in **IP⁷** Secure Gateway Release 5.0, the **IETF** has created newer versions of these protocols. This feature updates the

IP⁷ Secure Gateway and **EAGLE IPLIMx** implementation of these protocols to the current revisions.

**Note:**

This is a non-orderable feature required for the three **IETF** Connectivity features and the **IPLIM** Protocol Support Enhancement feature.

Hardware Requirements

This feature requires a **SSEDCM** (Single Slot Enhanced **DCM**).

3.95 IETF SCTP for “A” Link Connectivity (Release 28.1)

Description

To connect to a variety of **IP** enabled **SCP**'s, the **VXi** Softswitch, or other **IP** enabled network elements, the **EAGLE STP** and **IP⁷** Secure Gateway must use industry standard protocols. In the **IETF** Signaling Transport (**SIGTRAN**) model, **SCTP** is the transport layer for all the User Adapter layers.

SCTP is a reliable transport protocol operating on top of a connectionless packet network such as **IP**. It offers the following services to its users:

- acknowledged error-free non-duplicated transfer of user data,
- data fragmentation to conform to discovered path **MTU** size,
- sequenced delivery of user messages within multiple streams, with an option for unordered delivery of individual user messages,
- optional bundling of multiple user messages into a single **SCTP** packet, and
- network-level fault tolerance through supporting of multi-homing at either or both ends of an association.

The development of **SCTP** was necessitated by limitations within **TCP**. **TCP** has performed immense service as the primary means of reliable data transfer in **IP** networks. However, an increasing number of recent applications have found **TCP** too limiting, and have incorporated their own reliable data transfer protocol on top of **UDP**. The limitations which users have wished to bypass include the following:

- **TCP** provides both reliable data transfer and strict order-of-transmission delivery of data. Some applications need reliable transfer without sequence maintenance, while others would be satisfied with partial ordering of the data. In both of these cases the head-of-line blocking offered by **TCP** causes unnecessary delay.
- The stream-oriented nature of **TCP** is often an inconvenience. Applications must add their own record marking to delineate their messages, and must make explicit use of the push facility to ensure that a complete message is transferred in a reasonable time.
- The limited scope of **TCP** sockets complicates the task of providing highly available data transfer capability using multi-homed hosts.
- **TCP** is relatively vulnerable to denial of service attacks, such as **SYN** attacks.

The transport of **PSTN** signaling across the **IP** network is an application for which all of these limitations of **TCP** are relevant.

This feature is available on the **IPGWx GPL** and **IPLIMx GPL** in both the **EAGLE STP** and **IP⁷ Secure Gateway** products in Release 28.1 of the **EAGLE STP**, and **IP⁷ Secure Gateway** Release 5.0.

SCTP is a protocol designed to operate on top of a non-reliable protocol such as **IP**, but yet provide a reliable data delivery to the **SCTP** user.

Hardware Requirements

This feature requires a **SSEDCM** (Single Slot Enhanced **DCM**).

3.96 IETF SCTP Support (IP⁷ Release 5.0)

Description

SCTP is a reliable transport protocol operating on top of a connectionless packet network such as **IP**. It offers the following services to its users:

- Acknowledged error-free non-duplicated transfer of user data
- Data fragmentation to conform to discovered path **MTU** size
- Sequenced delivery of user messages within multiple streams, with an option for out-of-order-of-arrival delivery of individual user messages
- Optional bundling of multiple user messages into a single **SCTP** packet
- Network-level fault tolerance through supporting of multi-homing at either or both ends of an association

The development of **SCTP** was necessitated by limitations within **TCP**. **TCP** has performed immense service as the primary means of reliable data transfer in **IP** networks. However, an increasing number of recent applications have found **TCP** too limiting, and have incorporated their own reliable data transfer protocol on top of **UDP**. The limitations which users have wished to bypass include the following:

TCP provides both reliable data transfer and strict order-of-transmission delivery of data. Some applications need reliable transfer without sequence maintenance, while others would be satisfied with partial ordering of the data. In both of these cases the head-of-line blocking offered by **TCP** causes unnecessary delay.

The stream-oriented nature of **TCP** is often an inconvenience. Applications must add their own record marking to delineate their messages, and must make explicit use of the push facility to ensure that a complete message is transferred in a reasonable time.

The limited scope of **TCP** sockets complicates the task of providing highly available data transfer capability using multi-homed hosts.

TCP is relatively vulnerable to denial of service attacks, such as **SYN** attacks.

The transport of **PSTN** signaling across the **IP** network is an application for which all of these limitations of **TCP** are relevant.

Refer to the *Database Administration Manual - Features* for the current implementation of this feature.

New Hardware

Hardware support is required for implementation of the **IETF** Adapter Layer Support feature. Starting with this feature, the new **EDCM** card is introduced. Refer to the **NSD Hardware Manual** for current information on this card.

These differences in memory are the main reasons for hardware support. We are required to make both socket/association provisioning and card loading decisions differently based on the card type.

Upgrade Considerations

This feature has a unique upgrade consideration than other features in that the specification for which the feature is being developed is not "frozen" until after the feature is complete. This raises the issue of incompatibility between the final specification and this feature. Since the specification is the initial version for the adapter layer, the protocol has defined the version number to be fixed to 1. Therefore, it is not possible to modify the version number from this feature perspective. Another issue is that the impact of any specification changes after this feature is completed is not necessarily impacting the compatibility of the protocol. It is expected that the approved version of revision 1 of the adapter layers is supported at some period in time and that by upgrading the software solves compatibility issues. Another solution is to use a new adapter layer index for the pre-official version of the protocol and convert and fielded releases to the new adapter layer index. The **ASPLOG PASS** command shows the version of the **UA** adapter supported. The problem with supporting a revision of a draft is a later revision may be incompatible. The drafts make no provision for support between revisions so a revision 3 of version 1 **SUA** can't be differentiated between revision 6 of version 1 **SUA**.

Limitations

The memory requirements for an association are greater than for a socket. Because of this, more associations may be provisioned on the **EDCM** card.

Not only are socket/association limits based on memory, so is the ratio of associations to sockets. This ratio known as the "trade ratio" defines the number of sockets, which are equivalent to one association with respect to memory consumption.

3.97 IETF SUA for "A" Link Connectivity (Release 28.1)

To connect to a variety of **IP** enabled **SCP**'s, the **VXi** Softswitch, or other **IP** enabled network elements, the **EAGLE STP** and **IP⁷** Secure Gateway must use industry standard protocols. This feature implements the **SCCP** User Adaptation Layer (**SUA**). **SUA** is an adaptation layer protocol, similar to **TALI**, which transports **SCCP** User level protocols.

The **SUA** Layer was designed to fit the need for the delivery of **SCCP**-user messages (**MAP** & **CAP** over **TCAP**, **RANAP**, etc.) and new third generation network protocol messages over **IP** between two signaling endpoints. Consideration is given for the transport from an **SS7** Signaling Gateway (**SG**) to an **IP** signaling node (such as an **IP**-resident **Database**). This protocol can also support transport of **SCCP**-user messages between two endpoints wholly contained within an **IP** network. The layer is expected to meet the following criteria:

- Support for transfer of **SS7 SCCP**-User Part messages (e.g., **TCAP**, **RANAP**, etc.).
- Support for **SCCP** connectionless service.
- Support for **SCCP** connection oriented service.

- Support for the seamless operation of **SCCP**-User protocol peers
- Support for the management of **SCTP** transport associations between a **SG** and one or more **IP**-based signaling nodes).
- Support for distributed **IP**-based signaling nodes.
- Support for the asynchronous reporting of status changes to management.

Hardware Requirements

This feature requires a **SSEDCM** (Single Slot Enhanced **DCM**).

3.98 IETF SUA Support (Release 34.0)

Description

The IETF SCCP-User Adaptation (SUA) Layer Request for Comment (RFC) feature enhances IPGWx GPL software to support RFC with the following feature highlights:

- Replaces Draft Version 3 support on the IPGWx GPL with SUA RFC.
- Provides support for SCCP Connectionless messages via SUA CLDT and CLDR. Connection oriented messages are not supported.
- Provides support for SUA Signaling Network Management Messages.

Hardware Requirements

An EDCM (single-slot) P/N 870-2372-01 Rev E is required for SUA RFC.

Refer to the hardware baseline of this release.

Limitations

- The version of SUA implemented in this release is NOT backward compatible with the SUA version currently available on EAGLE 5 SAS releases.
- Only the Connections Message transfer part of the SUA protocol is supported for class 0 and class 1 SCCP messages.
- To remove a routing context from a routing key, the routing key must be deleted and re-entered.

3.99 Implementation of SNMP Agent (IP⁷ Release 2.0)

Overview

This feature implements a **Simple Network Management Protocol (SNMP)** agent on each **DCM** that runs an `ss7ipgw` or `iplim` general program load (**GPL**). SNMP is an industry-wide standard protocol used for network management. SNMP agents interact with network management applications called Network Management Systems (**NMSs**).

Supported Managed Object Groups

The SNMP agent maintains data variables that represent aspects of the DCM card. These variables are called managed objects and are stored in a management information base (**MIB**). The SNMP protocol arranges managed objects into groups. The following table shows the groups that **IP⁷** release 2.0 supports.

Table 3-12 SNMP Object Groups Supported by IP7 Release 2.0

Group Name	Description	Contents
system	Text description of agent in printable ASCII characters	System description, object identifier, length of time since reinitialization of agent, other administrative details
interfaces	Information about hardware interfaces on the DCM	Table that contains for each interface, speed, physical address, current operational status, and packet statistics
ip	Information about host and router use of the IP	Scalar objects that provide IP-related datagram statistics, and 3 tables: address table, IP-to-physical address translation table, and IP-forwarding table
icmp	Intranetwork control messages, representing various ICMP operations within the DCM	26 scalar objects that maintain statistics for various Internet Control Message Protocol (ICMP) messages
tcp	Information about TCP operation and connections	14 scalar objects that record TCP parameters and statistics, such as the number of TCP connections supported and the total number of TCP segments transmitted, and a table that contains information about individual TCP connections
udp	Information about UDP operation	4 scalar objects that maintain UDP-related datagram statistics, and a table that contains address and port information
snmp	Details about SNMP objects	30 scalar objects, including SNMP message statistics, number of MIB objects retrieved, and number of SuNMP traps sent

Supported SNMP Messages

The SNMP agent interacts with up to two NMSs by:

- Responding to *Get* and *GetNext* commands sent from an **NMS** for monitoring the DCM.
- Responding to *Set* commands sent from an NMS for maintaining the DCM and changing managed objects as specified.
- Sending *Trap* messages to asynchronously notify an NMS of conditions such as a link going up or down. *Traps* provide a way to alert the NMS in a more timely fashion than waiting to for a *Get* or *GetNext* from the NMS. In this release, only the following traps are supported:
 - *linkUp*, sent when one of the ports on the DCM initially comes up or recovers from a previous failure
 - *linkDown*, sent when one of the ports on the DCM fails

Deviations from SNMP Protocol

The following table shows how **IP7** release 2.0 deviates from the standard SNMP protocol definition.

Table 3-13 Deviations from SNMP Protocols

Group	Variable Name	Usage	Deviation
system	sysContact	Text identification of contact information for agent	Cannot be set by <i>Set</i> command; may be set only by <code>chg-sg-opts</code> command.
	sysLocation	Physical location of agent	Cannot be set by <i>Set</i> command; internally set using configuration data already available; set to <code><CLLI>-<slot of DCM></code>
	sysName	Administratively assigned name for agent	Cannot be set by <i>Set</i> command; internally set using configuration data already available; set to <code><CLLI>-<slot of DCM></code>
interface	ifAdminStatus	Desired state of the interface	Cannot be set by <i>Set</i> command (to ensure that an NMS does not disrupt SS7 traffic by placing an IP interface in a nonoperable state)
ip	ipForwarding	IP route-specific values	Cannot be set by <i>Set</i> command
	ipDefaultTTL		
	ipRoute Dest		
	ipRouteIfIndex		
	ipRouteMetric1-5		
	ipRouteNextHop		
	ipRouteType		
iprouteAge	IP-address specific information	Can be set by <i>Set</i> command, but not saved across DCM reloads	
ipRouteMask			
ipNetToMediaIfIndex			
ipNetToMediaPhysAddress			
	ipNetToMediaNetAddress		
	ipNetToMediaType		
tcp	tcpConnState	State of a TCP connection	Cannot be set by <i>Set</i> command
snmp	snmpEnableAuthenTraps	Indicate whether agent is permitted to generate authentication failure traps	Cannot be set by <i>Set</i> command

3.100 Improved Routing Management (Release 20.0)

This feature allows the **EAGLE** to use E-links, allows the user to make link type assignment for display purposes, and provides two new procedures for handling transfer-prohibited (**TFP**) network management messages.

Before beginning to route traffic on a non-normal route, the **EAGLE** sends a **TFP** network management message toward the affected destination. When an **STP** begins

using a lower priority route through another **STP** to its final destination, a **TFP** network management message is sent to all accessible adjacent **STPs** that provide a route to a higher priority. These two handling procedures prevent circular routing.

This feature also uses the ability to enable or disable the broadcast of **TFP** network management messages. This capability can be administered per linkset or per destination, and has no effect on the **EAGLE**'s method of responding to **TFP** network management messages.

3.101 IMSI Change with Single PDBI Command (EPAP 16.0)

The `upd_sub` command creates a new IMSI and deletes the previous IMSI associated with a specific DN. The `upd_sub` parameters are `iid nnn`, `imsi`, and `nimsi`.

The `upd_sub` command is issued to modify the IMSI with one command instead of the previous method of requiring two commands: one command to create a new IMSI entry, and a second command to delete the old IMSI entry.

Previously when an IMSI was reported as lost or stolen, the `ent_sub` command was used to create a new IMSI and associate the existing DN to this new IMSI. The old IMSI was left without an associated DN and was not automatically deleted from the Provisioning Database. These orphan IMSIs required deletion by a manual process to erase the unassigned entries.

3.102 IMSI Range Logic Support (Release 46.0)

The IMSI Range Logic Support feature includes an IMSI range check logic prior to an IMEI lookup in the EIR Database. This check prevents low ARPU users from using certain devices, in addition to the traditional EIR stolen handset check.

3.103 IMT Fault Isolation (Release 22.0)

IMT fault isolation increases the **EAGLE**'s ability to diagnose problems on the **IMT** bus with:

- Improvements to the **EAGLE**'s existing diagnostic and reporting mechanisms.
- Additional diagnostics and reports to enable the user to detect **IMT** faults and to isolate the cause of those faults to the card or bus level.

IMT fault isolation procedures are designed to be used after a problem has been detected. They can be used to solve these problems:

- Isolate **IMT** bus failures to the bus segment or individual card.
- Identify intermittent failures and the responsible cards.

There are two types of **IMT** bus errors, transient and nontransient. Transient errors cause packet loss or data corruption, but the cards are still connected to the **IMT** bus. Nontransient errors cause the cards to be disconnected from the **IMT** bus. The **IMT** fault isolation procedures detect nontransient errors.

Nontransient errors fall into two categories:

1. Errors that cause all cards to be isolated from one of the **IMT** buses (the **IMT** bus is out of service)
2. Errors that cause a subset of the cards (typically a single card) to be isolated from one of the **IMT** buses (the **IMT** bus remains in service).

When an **IMT** bus is out of service, this feature determines the location and probable cause of the failure. Those faults that are card-specific are isolated to the card. Faults that cannot be isolated to a specific card are isolated to the segment of the **IMT** bus on which they occur. A segment is identified by the two cards that are its endpoints. No attempt is made to isolate a particular component below the card level. The card is a field replaceable unit.

3.104 IMT Subsystem Alarms (Release 20.0)

With this feature, the **EAGLE** displays minor, major, or critical alarms should one or more of the buses in the Interprocessor Message Transport (**IMT**) subsystem fail. The alarm levels in the individual buses determine the overall alarm for the **IMT** subsystem.

3.105 INAP-based Number Portability (INP) (Release 26.05)

Description

Throughout the world, wireline and wireless operators are receiving directives from national regulators to support service provider number portability in their networks. This allows for subscribers to change to a new service provider while retaining their phone number. In Europe and other parts of the world, with the exception of North America, wireline providers are planning to implement this via the use of an **IN** (Intelligent Network)-based solution using the **INAP** (**IN** Application Part) protocol. This is in line with developed **ITU** Number Portability supplements. **ETSI** standards for Mobile Number Portability also define an **IN**-based solution to be used at the operator's discretion.

While the advent of number portability is good news for consumers, it presents many challenges for network operators. Tekelec's **INAP**-based Number Portability (**INP**) feature is intended to minimize those challenges for network operators, while enabling them to efficiently meet their regulatory obligations.

Refer to the *Feature Manual - INP* for the current details on this feature.

Hardware Requirements

INP requires the use of the **Multi-Purpose Server (MPS)** hardware to host the **EAGLE** Provisioning Application Processor (**EPAP**) software. Refer to the **NSD Hardware Manual** for the current hardware information.

3.106 Include optional CUG parameter in SRI_ACK (Release 42.0)

The Include optional CUG parameter in SRI_ACK functionality allows the *Closed User Group (CUG)-CheckInfo* parameter (if existing) in an incoming SRI message to be included in the outgoing SRI_ACK message.

The *CUG* parameter must be encoded in a definite length format and the parameter length must be 30 bytes or less before the entire parameter can be included in the SRI_ACK message. If the value is greater than 30 bytes, then only the *CUG-Interlock* and *CUG-OutgoingAccess* parameters are included in the SRI_ACK message. The *CUG-ExtensionContainer* is not included.

3.106.1 Feature Control Requirements

The G-Port feature (Part Number 893-0172-01) or IS41 GSM Migration feature (Part Number 893-0173-01) must be enabled before the CUG parameter functionality can be provisioned.

3.107 Incoming and Outgoing Linkset Name Added to the SLAN report for ECAP (ECAP 40.1)

ECAP has been updated with a new message format that supports the transmission of an MSU report from the SLAN to the ECAP. If provisioned properly in both EAGLE 5 ISS and ECAP, this new format includes the incoming and outgoing linkset names, in addition to the linkid, in the SLAN report. If this format is not provisioned, then the original message format is transferred to the ECAP.

For information on the EAGLE 5 ISS component of the addition of the incoming and outgoing linkset name to the SLAN report for ECAP, refer to *Database Administration Manual - Features and Commands Manual* for the EAGLE 5 ISS Release 40.1 documentation set.

Feature Control Requirements

The addition of incoming and outgoing linkset names to the SLAN report for ECAP has the following feature control requirements:

- The SLANLSN parameter of the chg-ss7opts command in EAGLE 5 ISS must be set to ON.
- The *Link Set Name included in Measurement File* option under the Optional Parameters menu of the `ecapcfg` must be set to Y.

The Optional Parameters options of the `ecapcfg` menu and their functions are provided in [Table 3-14](#).

Table 3-14 Optional Parameters Menu Options

Menu Option	Description	Range of Values
Optional Parameters	Displays a set of optional parameters that can be configured.	[1..2, E]
Link Set Name Included in Measurement File	If set to Y, then the Incoming/Outgoing Link Set Names will be placed in the output XML file. By default this field will be set to N (disabled).	[Y, y, N, n]
Linkid Included in Measurement File	If set to Y, then the linkid will be placed in the output XML file. By default, this field will be set to Y (enabled).	[Y, y, N, n]

 **Note:**

These parameters are only applicable if the EAGLE 5 ISS SLANLSN parameter is set to ON.

3.108 Increase E1T1 Link counts [3HSL 96LSL] on SLIC (Release 46.6)

This feature increases the link capacity of the E1T1 functionality on the SLIC (P/N 7094646) card to 3 High Speed Links (HSL) or 96 Low Speed Links (LSL). This allows for more links per card and fewer cards per node.



Note:

The GLSHC (Gateway Screening with TSM card) GPL, IPGHC GPL, and IPLHC (IPGWY and IPLIM) GPLs are no longer supported in Release 46.6 and later.

3.108.1 Hardware

The following table provides card replacement considerations:

Table 3-15 Replace Legacy Function Card with SLIC

Function	Card Type	System Action	Manual Action	Additional Hardware Action
IPSG (IP SIGTRAN Signaling)	ENET-B ENET-A	None	None	None
GTT EPAP ELAP	SM8G-B SM4G-A	None	None	None
ENUM	SM8G-B	None	None	Ethernet adapter required -DB26/ Dual-RJ45 adapter for GbE as ENET-B (P/N 830-1102-03)
EIR	SM8G-B	None	None	Ethernet adapter required -DB26/ Dual-RJ45 adapter for GbE as ENET-B (P/N 830-1102-03)
SIP NP	SM8G-B	None	None	Ethernet adapter required -DB26/ Dual-RJ45 adapter for GbE as ENET-B (P/N 830-102-03)
E1T1 (LSL/HSL)	E1T1-B E1T1-A	None	None	None

Table 3-15 (Cont.) Replace Legacy Function Card with SLIC

Function	Card Type	System Action	Manual Action	Additional Hardware Action
Measurements Platform (E5-MCPM-B)	MCPM-B	None	None	None
IP User Interface (E5-IPSM)	E5-IPSM ENET-B	None	None	None
Integrated Monitoring (E5-STC)	ENET-B ENET-A	None	None	None

 **Note:**

There are currently two (2) different ENET adapters used in connecting to EAGLE ENET ports. The first is used for SM cards, while the second is used for ENET link cards. With the SLIC card, the EAGLE has standardized on the 4-port EPMB ENET adapter for all ENET interfaces. This requires that a new adapter be installed between the backplane and the customer cable for all SM slots converted to SLIC cards.

 **Note:**

For SMxG cards, the ELAP and ELAP function replacement with SLIC cards requires the 830-1102-03 adapter.

3.109 Increase Gateway Screening Screen Sets to 255 (Release 22.0)

In Release 22.0, the total number of gateway screening screen sets that can be configured in the database has been increased from 64 to 255. When a screening table is changed, this feature displays the following scroll area message showing the number of screen sets affected by changing a screening table. There is no limit to the number of screensets a screening table can be a member of.

Notice: The number of screensets affected is N.

Where n is the number of affected screen sets.

3.110 Increase GTT Entries per TT to 200,000 (Release 29.0)

Description

This feature increases the number of Global Title Table entries per **Translation Type** or **GTT** Set up to 200,000. The **GTT Entries Increase per TT to 200,000** Feature does not have any software controls, and therefore no feature keys. The feature is automatically included as part of **EAGLE 29.0/IP7** Secure Gateway 7.0, provided that all **SCCP** cards are **TSMs** or **DSMs**.

Hardware Requirements

To support this feature, all **SCCP** cards in the system must be **TSMs** or **DSMs**.

3.111 Increase in Time Zones (EAGLE Release 30.0/IP7 Secure Gateway Release 8.0)

Description

The Increase in Time Zones feature increases the number of time zones available for **EAGLE** administration; see the following table.

Table 3-16 New Supported Time Zones

Time Zone	Abbreviation	Offset from GMT (hrs.)
Newfoundland Daylight Time	NDT	- 2.5
Newfoundland Standard Time	NST	- 3.5
Brazil Standard Time	BRA	- 3
Alaska Daylight Time	AKDT	- 8
Alaska Standard Time	AKST	- 9
Universal Time Coordinated	UTC	0
British Summer Time	BST	+ 1
Western European Summer Time	WEST	+ 1
Central European Time	CET	+ 1
Central European Summer Time	CEST	+ 2
French Winter Time	FWT	+ 1
French Summer Time	FST	+ 2
Middle European Time	MET	+ 1
Middle European Summer Time	MEST	+ 2
Eastern European Time	EET	+ 2
Eastern European Summer Time	EEST	+ 3
South African Standard Time	SAST	+ 2

Table 3-16 (Cont.) New Supported Time Zones

Time Zone	Abbreviation	Offset from GMT (hrs.)
Moscow Time	MSK	+ 3
Moscow Summer Time	MSD	+ 4
India Standard Time	IST	+ 5.5
India Daylight Time	IDT	+ 6.5
China Coast Time	CCT	+ 8
Republic of Korea	ROK	+ 9
Australian Western Standard Time	AWST	+ 8
Australian Western Daylight Time	AWDT	+ 9
Australian Central Standard Time	ACST	+ 9.5
Australian Central Daylight Time	ACDT	+ 10.5
Australian Eastern Standard Time	AEST	+ 10
Australian Eastern Daylight Time	AEDT	+ 11
New Zealand Standard Time	NZST	+ 12
New Zealand Daylight Time	NZDT	+ 13

Prior to this feature, the **EAGLE** administration supported the time zones shown in the following table.

Table 3-17 Currently Supported Time Zones

Time Zone	Abbreviation	Offset from GMT (hours)
Greenwich Mean Time	GMT	0
US Eastern Daylight Time	EDT	- 4
US Eastern Standard Time	EST	- 5
Pacific Daylight Time	PDT	- 7
Pacific Standard Time	PST	- 8
Mountain Daylight Time	MDT	- 6
Mountain Standard Time	MST	- 7
US Central Daylight Time	CDT	- 5
US Central Standard Time	CST	- 6
Hawaiian Daylight Time	HDT	- 9
Hawaiian Standard Time	HST	- 10
Atlantic Daylight Time	ADT	- 3
Atlantic Standard Time	AST	- 4
Western European Time	WET	0

As a result of this feature, all output banners and display of time zones in output content now allow 4 spaces for the time zone.



Note:

This does not include **SEAS** output headers, which will remain at 3 characters. All 4-character time zones will be truncated to 3 characters in **SEAS** output.

Hardware Requirements

No new hardware is needed to support this feature.

3.112 Increase IPSP SIGTRAN connections (Release 46.5)

This feature increases the number of associations per SLIC card loaded with the IPSP GPL from 32 to 128.

The supported signaling ports are a, a1 to a63 and b, b1 to b63.

See *Database Administration - IP7 User's Guide* for more information.

3.113 Increase IPSP TPS [10k] on SLIC (Release 46.4)

This feature increases the TPS for IPSP on SLIC to 10K with IPSP High Throughput turned OFF.



Note:

If IPSP High Throughput is turned ON for SLIC hardware, the hardware will not support rates exceeding 10K.

3.114 Increase IPSP TPS [10k] on SLIC (Release 46.4)

This feature increases the TPS for IPSP on SLIC to 10K with IPSP High Throughput turned OFF.



Note:

If IPSP High Throughput is turned ON for SLIC hardware, the hardware will not support rates exceeding 10K.

3.115 Increase IP-RTE Table to 2048 Entries (Release 45.0)

Currently 1024 entries are supported in the EAGLE IP-RTE tables. The Increase IP-RTE Table to 2048 Entries feature increases the number of entries to 2048 entries. The IP-HOST table is also increased from the current 2048 entries to 4096 entries. The Increase IP-RTE Table to 2048 Entries feature also updates the MAXENTRIES for `rtrv-ip-rte` and `rtrv-ip-host` CSV output.

3.116 Increase LNP DB Capacity (504M) (Release 46.3)

The 504M LNP Entries feature increases the LNP capacity from 384 million to 504 million Telephone Number (TN) or Number Pool Block (NPB) records, where NPBs represent a block of 1,000 pooled numbers. The overall LNP Solution architecture remains the same.

Maximum data types per LNP Solution are as follows:

Table 3-18 Max Data

Data Type	LNP 384M Solution	LNP 504M Solution
TN	384,000,000	504,000,000
NpaNxx	350,000	350,000
Lrn	200,000	200,000
Mr	2,000,000	2,000,000
LrnMr	2,000,000	2,000,000
OGTT	200,000	200,000

3.117 Increase System-Wide IP Signaling Connections (Release 31.6)

This feature increases the system-wide number of IP signaling connections from 250 to 4000.

Table 3-19 Total IP Signaling Connections Supported

Type	Cards Per System	Links Per Card	IP Connections Per Link	Total Connections
IPLIMx	100	8	1	800
IPGWx	64	1	50	3200
System				4000

Because **M3UA** and **SUA** protocols require an **ASP** to be assigned to each association (connection), the number of supported ASPs is increased by the equivalent number.

This feature combines the ASP table with the **IPAPSOCK** table, but still refers to the ASP table in **MTT** errors and command output. The IPAPSOCK table has been expanded to contain a maximum of 4000 entries.

The system-wide number of ASPs has been increased from 250 to 4000.

This feature increases the number of system-wide IP signaling connections to 4000.

3.118 Increase System-Wide IPGWx TPS (Release 31.6)

This feature increases the limit on the number of **SS7IPGW** and **IPGWI** cards from 2 each (4 total) to a total of 64 cards system wide. Each **IPGWx** card will continue to host one and only one signaling link. This feature implements a new maximum limit of 8 **IPGWx** links per linkset, if the linkset does not have a mate linkset (mate-set).

Each **IPGWx** card is now rated at 2000 **TPS**.

An **IPGWx** mate-set can now be defined in terms of linkset configuration, rather than simply in terms of application type. An **IPGWx** mate-set is comprised of **IPGWx** cards hosting links in the same linkset or in the same combined-linkset with mated linksets.

An **IPGWx** mate-set is a group of **IPGWx** cards that act together to carry traffic between the **SS7** network and a set of **IP**-based **MTP** user-part applications. As an example, the **M3UA/SUA Application Server** state needs to be maintained throughout an **IPGWx** mate-set, but is not maintained across multiple **IPGWx** mate-sets.

Prior to this feature, the **IPGWx** application simple definition of mate-set was that the cards running the same **IPGWx** application are considered mates. An **IPGWx** mate-set can now be defined in terms of linkset configuration, rather than simply in terms of application type. An **IPGWx** mate-set is comprised of **IPGWx** cards hosting links in the same linkset or in the same combined-linkset with mated linksets. This feature adds `matelsn` as a new parameter to the Change Linkset (`chg-ls`) command, thereby providing for the assignment of an **IPGWx** mate linkset. In addition, the `CHG-LS` command now uses the '`action=delete`' parameter to delete a configured `matelsn`. The `matelsn` linkset parameter provides backward compatibility with the current combined-linkset **IPGWx** mate-set deployments.

While deployment of **IPGWx** using combined linksets remains supported, the recommendation is that each **IPGWx** mate-set be deployed with a single linkset. Any N+K redundant configuration of **IPGWx** can be deployed, as long as the number of cards in the mate-set is 8 or less and the system-wide limit is not exceeded. Because each **IPGWx** card is now rated at 2000 **TPS**, the maximum transaction rate to/from a single **IP**-based point code for the **IPGWx** will be 14000 **TPS** (7+1 redundancy). If the maximum number of **IPGWx** cards is deployed (64 cards) using 8 mate-sets (linksets), then the total system-wide **IPGWx** transaction rate will be 112,000 **TPS** (7+1 redundancy).

Hardware Required

This feature requires **SSEDCM** cards running the **IPGWx** applications.

3.119 Increase the number of entries in Vendor Prefix table (Release 46.4)

This feature increases the number of Vendor Prefixes from 32 to 128. This results in the Vendor number range in the Vendor ID Table increasing from 32 to 128.

This feature supports the GSM MAP SRI Redirect feature. See *G-Port - User's Guide* for more information on the GSM MAP SRI Redirect to Serving HLR feature.

3.120 Increase the Number of Mated Application Entries (Release 22.0)

Release 22.0 increases the number of entries that the mated applications table can contain from 256 to 1024.

3.121 Increase the number of supported Service Module cards per node(Release 46.5)

This feature increases the number of supported SM cards from 32 to 40, as described in the following table:

Table 3-20 EAGLE Service Module Card Limits

Description	New Limit (Cards per EAGLE)	Existing Limit (Cards per EAGLE)
Eagle deployed with 1 EPAP and 1 ELAP (Dual ExAP)	58	32
Any card connected to EPAP*	40	32
Any card connected to ELAP**	18	18
SCCP cards (Cards provisioned with APPL=VSCCP)***	40 + 1 (in N + 1 config)	32
SIP	16	16
DEIR	16	16
ENUM	16	16

* - This includes SCCP cards of data type DN, IMSI or EPAP, SCCP cards with no data type if EPAP based services are turned ON, SIP cards with DATA=EPAP, ENUM and DEIR cards.

** - This includes SCCP cards of data type ELAP, SCCP cards with no data type if LNP services are turned ON and SIP cards with DATA=ELAP.

*** - The maximum number of SCCP cards that can be brought into service depends on the status of various ExAP-based features enabled in the system.

3.122 Increased GTT Transactions (Release 21.0)

This feature increases the performance of the global title translation (**GTT**) feature from 9300 **MSUs** per second to 21,000 **MSUs** per second when the **GTT** table is at its full capacity.

3.123 Increased Linkset Capacity (Release 28.0)

Description

This feature increases linkset capacity to support a *maximum* of 1024 linksets.

Note:

For Release 28.0, only 255 of the linksets can be *gateway linksets*. A gateway linkset is a linkset that contains routes to a different network indicator (**NI**) than the network indicator of the **EAGLE**, or that has **Gateway Screening (GWS)** on the linkset.

New Hardware Required

There are no additional hardware requirements for the Increased Linkset Capacity feature.

3.124 Increasing the Size of the Service Provider ID Table (Release 23.2)

In Release 23.2, the number of service providers that can be configured in the **EAGLE** database for the **Local Number Portability** feature with the `ent-lnp-sp`, `ent-lnp-lrn`, and `ent-lnp-sub` commands has been increased 100 to 250. If the service provider **ID** table is full when either of these commands are executed, the command is rejected with this message.

Error Messages

```
E3133 Cmd Rej: LNP Service Provider table is full
```

The output of the `rtrv-lnp-sp` command has been changed to show that the total number of entries in the service provider **ID** table is now 250. The percentage of the maximum number of entries that the service provider **ID** table contains is based on the 250 entries that the service provider **ID** table can contain.

3.125 Info Analyzed Relay (Release 41.1)

Info Analyzed Relay (**IAR**) consists of four features:

- **IAR Base**
The IAR Base feature intercepts and processes AnalyzedInformation messages that are sent from a Mobile Switching Center (**MSC**) to a Service Control Point (**SCP**) or Services Node (**SN**). This feature supports the message processing functionality used by the IAR Additional Subscriber Data, IAR Generic Routing Number, and IAR Number Portability features.
- **IAR Additional Subscriber Data (IAR ASD)**
The IAR **ASD** feature allows Additional Subscriber Data lookups to be performed on AnalyzedInformation messages.
- **IAR Generic Routing Number (IAR GRN)**
The IAR GRN feature allows Generic Routing Number lookups to be performed on AnalyzedInformation messages.
- **IAR Number Portability (IAR NP)**
The IAR NP feature allows the EAGLE 5 ISS to treat messages that relate to ported subscribers differently than non-porting subscribers. This feature provides support for IAR Service Portability.

These features allow the EAGLE 5 ISS to provision subscriber data used to screen and manipulate AnalyzedInformation messages. After IAR processing, other network entities do not have to distinguish one kind of subscriber from another, but only react to message data that is already screened and manipulated by the EAGLE 5 ISS.

3.125.1 Feature Control Requirements

- IAR Base feature
 - FAK for Part Number 893-0342-01
 - The GTT feature must be turned on before the IAR Base feature can be enabled.
 - The STPOPTS **defcc** option must have a value other than **none** before the IAR Base feature can be enabled.
 - If the STPOPTS **ansigflex** option is set to **yes**, then the IAR Base feature cannot be enabled.
 - A temporary FAK cannot be used to enable the IAR Base feature.
 - The IAR Base feature cannot exist on the same node as the LNP features.
 - The IAR Base feature does not require EPAP.
 - Common Screening List entries for the CCNC, TRIG, and GT lists can be provisioned when the IAR Base feature is enabled.
 - Options in the TATROPTS table and the TATR-MSG table can be provisioned when the IAR Base feature is enabled.
 - The IAR Base feature must be enabled or the IDPR feature must be turned on before the **ttr** Service Selector can be provisioned.
 - The IAR Base feature must be enabled before the **feat=iar** option can be provisioned for the `tst-msg` command.
 - The IAR Base feature cannot be turned off after it has been turned on.
- IAR NP, IAR ASD, and IAR GRN features
 - A FAK for the appropriate Part Number (IAR NP: 893-0261-01, IAR ASD: 893-0350-01, IAR GRN: 893-0351-01)
 - The IAR Base feature must be enabled before the IAR NP, IAR ASD, or IAR GRN feature can be enabled.
 - The features can be turned on and off.
 - A temporary FAK cannot be used to enable any of the features.
 - The features require EPAP.

3.126 INP Circular Route Prevention (Release 41.1)

The INP Circular Route Prevention feature detects and prevents circular routes for INPQ and INP MR Services. INPQ services are associated with received queries (InitialDP for INP-based queries or NPREQ for AINP-based queries) and the results are generated based on the RTDB lookup. INP MR services are associated with received INP queries that are related to the destination.

3.126.1 Feature Control Requirements

- A FAK for Part Number 893-0285-01
- A temporary FAK cannot be used to enable the feature.

- The INP feature (Part Number 893-0179-01) must be turned on before the INP CRP feature can be enabled.
- The INP CRP feature can be turned on and off.

3.127 INP, G-port, and ATI NP Enhancements for Support of ROP (Release 41.1)

The INP, G-Port, and ATINP features are enhanced to allow Small Geographic Areas (CNLs) to be grouped into Large Geographic Areas (ROPs). This grouping simplifies the routing and allows a call to be delivered as close to the interconnection destination as possible.

ROP information is stored in the generic routing number (GRN) field. Both **CNL** and **ROP** information can be provisioned for a single subscriber entry; however, only one of the CNL or ROP fields can be selected for the outgoing message.

The G-Port SRI Query for Prepaid, AINPQ, IS41 GSM Migration (IGM), and SRI Redirect features also support ROP.

3.128 INP, G-Port, and ATINP Enhancements for Support of ROP (EPAP 13.0)

The INP, G-Port, and ATINP Enhancements for Support of ROP feature allows additional data to be associated with a subscriber (DN) or a range of subscribers. This data is called Additional Subscriber Data (ASD).

Some countries use an additional piece of information called the CNL (Small Geographic Area) for number porting. Each ported subscriber in these countries must be associated with a CNL. CNLs can be clustered into groups called ROPs (Large Geographic Area) to simplify the routing.

The GRN field in EPAP stores the ROP information. A customer may have both CNL and ROP for a single subscriber entry, but the allowed provisioning on the ATINP, G-Port and INP features only allow one of these fields to be selected in the outgoing message.

For EPAP, this feature adds the ROP into the GRN field. There is a new mapping table, the Generic Mapping Table (GMT) that is used to add the CNL to ROP mappings. If a CNL is configured, it triggers an automatic lookup of the GMT and back-populates the GRN field with the retrieved ROP information.

Limitations

Each feature being modified requires the base feature or capability on which it is built, specifically:

- ATINP (all protocol versions) with GRN - requires ATINP (all protocol versions)
- G-Port and G-Port SRI Query for Prepaid with GRN - requires G-port and G-port SRI Query
- INP and/or AINPQ with GRN - requires INP and/or AINPQ

This feature is mutually exclusive with all other features that use the GRN field to carry feature specific information. Examples are IDP A-Party Blacklist, TIF, and MO-SMS.

3.129 INP Number Normalization (Release 26.3)

Description

The **INP** Number Normalization feature allows the **INP** feature to accept queries either with or without special prefixes on the **DN**. Upon receipt, **INP** will strip off the prefix (if specified by the **chg-inpopts** command), convert the **DN** to international, perform the database query, and return a response to the switch. The CalledPartyNumber in the response may include the special prefix or not, depending on operator configuration of the feature. **INP** Number Normalization also allows the **NAI** in an incoming query to be mapped to an internal service **NAI**.

Hardware Requirements

The **INP** Number Normalization feature requires the Multi-Platform Server (**MPS**) system and the **EAGLE STP Database Services Module (DSM)** subsystem. This hardware was first introduced in **EAGLE** Release 26.1.

3.130 INP Service Portability (Release 41.1)

Service Portability support for the **INP** feature determines whether Service Portability applies to InitialDP messages for own-network subscribers. When Service Portability is applicable, GRN digits are used for RN digits in the response message.

The **INPMR** service allows modification of SCCP CdPA digits for outbound **MSUs** based on EPAP entity "digit action" (**DA**). The Entity ID digits used in formatting the SCCP **CdPA** digits for own-network subscriber (**SP**, or **RN/PT=0** with either **IGM** or **S-Port** on) are determined by **RTDB** lookup results and feature configuration options. The digits can be GRN digits (from Service Portability support), Default Routing Number, or Entity digits.

3.131 Integrated Monitoring for E5-E1T1 (Release 35.1)

Description

The Integrated Monitoring for **E5-E1T1** feature enhances the **E1/T1 MIM** on **EPM (E5-E1T1)** feature by adding **EAGLE 5 ISS** support for use of the Integrated Message Feeder (**IMF**) platform to monitor link status, link states, and **MSU** traffic on low-speed links for the **E5-E1T1** card.

See also **E1/T1 MIM** on **EPM** feature and **E1/T1 MIM** on **EPM** for a discussion of support for **E1** functionality and **SE-HSL** links.

Note:

The Integrated Monitoring for **E5-E1T1** feature is supported only for channelized links on **E5-E1T1** cards.

Hardware Requirements

The **E1/T1 MIM** on **EPM** feature requires **HIPR** cards on each shelf that contains **E5-E1T1** cards.

Limitations

EAGLE 5 ISS provides **IMF** support for only low-speed and channelized links. **SE-HSL** links and non-channelized links do not have **IMF** support.

3.132 Integrated SE-HSL Data Feed at 1 Erlang (Release 37.7, 39.0)

The Integrated SE-HSL Data Feed at 1 Erlang core enhancement allows the E5 Integrated Monitoring Support feature to operate at 1.0 Erlang traffic rate.

3.133 Interim Global Title Modification (IP⁷ Release 2.2)

The feature is also known as Prefix Deletion of Global Title. The **IP⁷** Secure Gateway changes the **SCCP** called party address for certain **TTs** before routing the message, but after **GTT** is performed, in one of the following ways:

When the **IP⁷** Secure Gateway receives a message that requires global title translation and contains one of the following **TT** values:

- 180–190
- 202
- 203
- 210–215

it does the following:

1. Performs the global title translation
2. Deletes the first three digits
3. Forwards the message

When the **IP⁷** Secure Gateway receives a message that requires global title translation and contains a **TT** value of zero, it does the following:

1. Performs the global title translation
2. Deletes the first three digits if they are 050 or 051
3. Forwards the message

These **TT** values cannot be provisioned or otherwise changed by the user.

3.134 Intermediate GTT Loadsharing (Release 28.1)

Description

This feature provides **EAGLE** the ability to load share between multiple nodes after global title translation, when the post-**GTT** message is **Route-on GT** (intermediate **GTT**).

Previously, the **EAGLE** only allowed load sharing between multiple nodes when the **EAGLE** was performing final **GTT**. Final **GTT** means the result of the **EAGLE**'s translation is a point code (**PC**) and subsystem number (**SSN**), and the routing

indicator in the outgoing message is set to **Route-on-SSN**. The load sharing is accomplished by accessing a mated application (**MAP**) table, which specifies the **PC**, **SSN** and relationship of a mated node. This load sharing mechanism was not allowed if the **EAGLE** was performing intermediate **GTT**, where the routing indicator in the outgoing message was set to **Route-on-GT**.

Some customers have a need to load share between nodes even when the **STP** is performing intermediate **GTT**. This may occur in a network that does not use capability point codes (**CPC**). This generally occurs in a quad-**STP** configuration where the first **STP** pair performs an intermediate **GTT**, and then must load share to the second **STP** pair, which will then perform the final **GTT**. If a **CPC** is not available for routing to the second **STP** pair, up to now there has been no way for the **EAGLE** to perform load sharing.

This feature supports a minimum of 1700 **GTT** transactions per second per **DSM** card, or 850 **GTT** transactions per second per **TSM** card while running **GTT**, **VGTT**, **EGTT**, and Global Title Modification.

Hardware Requirements

No new hardware is needed to support this feature.

Limitations

Any given **PC** can be part of only one **PC** group, i.e., any **PC** entered as part of a **PC** group cannot later be made part of a different **PC** group, unless it is first deleted from the initial group.

3.135 Intra Network Number Portability (Release 46.1)

The Intra Network Number Portability feature provides the enhanced ability to identify intra-circle and inter-circle calls. Before the Intra Network Number Portability feature, the GSM MAP SRI Redirect to Serving HLR feature identified the serving HLR based on the Circle Type and Circle Number for operators. With the Intra Network Number Portability feature, each Circle has a unique GRN, a unique Vendor Type, and a unique Vendor Number. The Intra Network Number Portability adds the new option GSMOPTS:SRIRDCTENT with two possible values: GRN, SP. The Intra Network Number Portability feature changes provide the G-Port feature with the correct routing information for calls.

3.136 Intrusion Alert (Release 21.0)

To alert the **EAGLE** system administrator to a possible attempt by an unauthorized person trying to login to the **EAGLE**, the **EAGLE** issues a scroll area message. When 5 or more consecutive attempts to login to the **EAGLE** have failed, the following scroll area message is sent to all terminal ports that can receive unsolicited Security Administration messages:

```
Info: xxxxxxxxxx successive LOGIN failures on port pp
```

Where:

xxxxxxx is the number of consecutive login failures on the port (1 - 4, 294, 967, 295)

pp is the terminal port (1 - 16) that the login attempts were made on.

When the attempt to login to the **EAGLE** is successful after a series of failed consecutive login attempts, or if the active **MASP** reboots, the count of failed consecutive login attempts for that port is reset to 0.

Attempts to login to the **EAGLE**, which are not completed normally, are not considered login attempts and are not included in the count of failed consecutive attempts. For example, while prompting for a password, you might use the F9 key to abort the command, or errors might occur when the **EAGLE** is looking up a user **ID** or password.

3.137 IP Signaling Gateway (IPSG) (Release 38.0)

The IP Signaling Gateway (IPSG) feature provides a signaling gateway (**SG**) application as an alternative to the IPLIM and IPGW applications. However, the IPLIM and IPGW applications continue to be supported.

The IPSG feature can run the M2PA and M3UA protocols simultaneously on the same card. The feature also supports ANSI, ITU-N or ITUN-24, and ITU-I simultaneously on one card and one association.

The IPSG feature runs on the E5-ENET card and introduces an **ipsg** application and GPL. An E5-ENET card running the **ipsg** GPL is referred to as an IPSG card. ISUP screening of MSUs over IP links is supported on IPLIM, IPGW, and IPSG cards.

For the M3UA protocol, the IPSG feature equates a linkset with an application server (**AS**) and equates a signaling link with an application-server/application server process instance (**AS-ASP**).

The IPSG feature introduces IPSG-M3UA and IPSG-M2PA signaling links. Up to 16 of each link are supported per IPSG linkset. Up to 32 IPSG-M2PA or IPSG-M3UA links are supported per IPSG card. Up to 16 cards are supported per linkset for either the M2PA or M3UA protocol.

The IPSG-M2PA signaling link can run the ANSI or ITU protocol, but not both simultaneously. ANSI and ITU can run on the same IPSG card on separate IPSG-M2PA signaling links. ANSI and ITU can run on the same IPSG-M3UA signaling link.

A series of three IS-NR link count thresholds are used to control the transition of the IPSG-M3UA links between Allowed, Restricted, and Prohibited states.

M2PA links on IPLIMx and IPSG cards can exist in the same linkset. M3UA links on IPSG and IPGWx cards cannot exist in the same linkset. M2PA and M3UA links cannot exist within the same linkset.

Each IPSG card can host up to 32 SCTP associations. A maximum of 16 M3UA links or 1 M2PA link can be assigned to an association. M3UA and M2PA cannot be mixed on the same association.

The SCTP ADLER-32 or CRC-32 checksum algorithm can be selected for an individual IPLIM, IPGW, or IPSG card.

The adjacent point code (**APC**) of the IPSG-M3UA linkset is the point code assigned to an AS.

As part of this feature, the IPGWx Signaling TPS FAK is removed.

The IPSG feature works in conjunction with the SIGTRAN Measurements Phase 1 feature. The IPVSHL and the IPVL link classes introduced in the SIGTRAN feature are

used for the M2PA and the M3UA links, respectively. See the [SIGTRAN Measurements Phase 1 \(Release 38.0\)](#) feature description for more information.

3.137.1 Feature Control Requirements

There are no feature control requirements identified for this feature.

3.137.2 Hardware Requirements

The IPSPG feature requires E5-ENET cards.

3.137.3 Limitations

The IPSPG feature has the following limitations:

- The SUA protocol is not supported.
- All associations for a card must be brought down before the checksum can be changed for the card.
- Only one checksum can be supported for a card.

3.138 IP Signaling Serviceability (Release 35.0)

Description

The IP Signaling Serviceability feature enhances the IPLIMx and IPGWx applications to improve serviceability in the following areas:

- New UIMs/UAMs for IPGWx and IPLIMx applications
- Enhancements to routing key commands
- Prevent alternative routes to APCs or SAPCs for IPGWx linksets
- Improvements to PASS commands
- Allows enabling and configuring UA Heartbeat messages, which ensure that UA peers are available to each other for M3UA and SUA associations
- Enhance `rept-stat-card` command
- Enhancements to association commands

Note:

Release 35.0 introduced E5-ENET cards, which provide a higher capacity for IPGWx and IPLIMx applications. However, the IP Signaling Serviceability feature runs on SSEDCCM and DCM cards as well as cards.

Hardware Requirements

The IP Signaling Serviceability feature has the following hardware requirements:

- HIPR cards must be installed in any shelf that contains E5-ENET cards.
- An adapter cable per Ethernet port

Limitations

The IP Signaling Serviceability feature has the following limitations:

- If multiple remote IP destinations are advertised and are using only one local interface (no alhost is provisioned) and the Ethernet interface goes down for the unused local network, then the “IP Connection Restricted” alarm does not appear because it is not being used to reach the remote IP destination.
- UIMs are issued when an M3UA/SUA message is received from the far end and results in the SG discarding the message. The generation of these UIMs is paced to occur every 30 seconds: therefore, if multiple messages result in a discard within that 30 seconds, a UIM is only generated for the first message that is discarded.

3.139 IP User Interface: Telnet Support (Release 29.0) (IP7 Release 7.0)

Description

This feature supports **IP**-based connections to the **EAGLE UI** via a telnet client. The Telnet feature adds up to 8 connections via a single **IPSM** card, up to 3 cards per system (total 24 telnet access ports), in addition to the existing 16 **RS232** terminal ports.



Note:

This feature is for use within a customer's private network **ONLY**. Connectivity to the Internet is **NOT** recommended, since no encryption scheme has been implemented to protect passwords transmitted across the network to the **EAGLE**.

Key benefits of this feature are:

- Access speed is improved;
- Remote access is enabled;
- Dial-up will not be required;
- Additional **EAGLE UI** access points;
- Access to the **EAGLE UI** from a network;
- Improved **UI** speed and data throughput;
- Provide a robust platform for future **IPUI** development.

The additional ports are accessible from any existing **LAN** or **WAN** connection along a customer's **IP**-based network. Craftspersons only need access to a standard **telnet** client in order to connect to and work on the **EAGLE**.

This feature targets the customer's demand for improvements to the **EAGLE UI** in the areas of network management, provisioning and maintenance tools, for which this feature provides a foundation.

As the first step in developing user interface improvements, this feature moves away from dedicated, hard-wired **RS232** ports, and adds **IP**-based **UI** connections to the **EAGLE**.

With this feature, **IP**-based access provides a standard interface via which **EAGLE** commands are entered from a telnet session to the **EAGLE**. The **EAGLE** then provides command responses back to the remote telnet terminal. The **EAGLE** can, in this case, provide responses without pacing (slowing down) the output.

Initially, **EAGLE** telnet sessions resemble **EAGLE** user interface in **KSR** mode. This feature is the first delivery of **UI** enhancements; additional features will build on the Telnet **UI** foundation.

The **IPUI** solution consists of adding 1 to 3 **IPSM** cards, with **IP** connectivity, to the **EAGLE**. This enables telnet clients to connect from anywhere on the customers' **IP LAN**.

Refer to the *Database Administration Manual - System Management* for current information on this feature.

Hardware Requirements

This feature requires a **IPSMI** card for every 8 terminal ports, to a maximum of 24 **IP** terminal ports per system.

Limitations

- This feature does not provide the client telnet application.
- Some function keys are not supported, but alternative keystrokes are identified.
- The **ECHO** command between **TELNET** devices and serial terminals is not supported.
- **LOCK** command not supported from **TELNET** terminals.
- **EAGLE** commands `chg-secu-trm` and `rtrv-secu-trm` are not supported for telnet terminals.
- Persistent-device-states feature must be **ON**, for telnet terminals to default to Inhibited state, through initializations and reboots.
- Entering new passwords, or changing existing passwords is not supported from telnet terminals. This covers the commands `chg-user`, `ent-user`, `dlt-user`, and `chg-pid`. Security-related activity must be performed through a serial terminal (Terminals 1-16). Also, new users logging in for the first time, or users updating expired passwords, or any other activity where the **EAGLE** prompts for a new password, must be performed from a serial terminal.

3.140 IP⁷ Internationalization (IP⁷ Release 4.0)

This Feature the following topics:

- **Multiple Point Code** Support
- Replacing Two **EThis** fetexisting **STP** Pairs with One **SG** Pair
- Multiple Linksets Between Two Nodes

Refer to the *Database Administration Manual - SS7* for the current details of the feature.

Impact on Other Features - Local Subsystems

The **SG** allows only the **True Point Code** to be entered into the **MAP** table. Also, the **SG** continues to allow the user to enter translations to the **True Point Code**, but the **SG** does not allow the user to enter translation to a **Secondary Point Code**.

If a node sends a rt-on-gt query, the node should set the query's **DPC** to be the **SG's Capability Point Code**. If a node sends a rt-on-ssn query, the node should **Summary of Modifications**

3.141 IP⁷ Transport Feature (Release 26.1)

Description

To address the technological needs of the convergence of voice and data networks, Tekelec introduces the **IP⁷** line of products. This product line addresses the needs of **SS7** and **IP** converged networks, assuring the seamless and secure transfer of voice and data signaling traffic and providing carriers with a full portfolio of applications, including an **SS7/IP** gateway, internetwork routing, and **SS7/IP** internetwork services.

New Features

The initial release of the **IP⁷** Transport feature supports the following functions related to **SS7/IP** convergence.

- The `iplim` application provides point-to-point connectivity (a single **TCP/IP** connection from a **DCM** card to another device) within an **ANSI** network, specifically, **SS7-over-IP** for point-to-point signaling links (B/C/D links) between **STPs**.
- The `iplimi` application provides the same connectivity for International Telecommunications Union (**ITU**) point codes that the `iplim` application provides for **American National Standards Institute (ANSI)** point codes.
- Two-point **IPLIMx** allows a single **DCM** card loaded with the `iplim` application or the `iplimi` application to support two point-to-point links. In previous releases, each point-to-point link required a separate **DCM** card.
- Support for up-to-41 **DCMs** that run the `iplim` or `iplimi` application.
- A new **DCM** card, capable of supporting up-to-2000 **MSUs** per second, can be loaded with the `iplim` or `iplimi` application; customers can use any combination of the original and new **DCM** cards.

This section refers to the `iplim` and `iplimi` applications by the term '**IPLIMx**' when discussing their common functions.

Refer to the *Database Administration Manual - SS7* for current information on this feature.

3.142 IPGWx Congestion Enhancement (Release 35.1)

Description

The IPGWx Congestion Enhancement feature changes the origination point of a **Route Congestion Test (RCT)** message to enable the Transfer Congested (**TFC**) message that is sent in response to reach its destination.

When an abatement procedure for a congested **SS7** destination for a **IPGWx**-connected endpoint begins, a message exchange, consisting of an **RCT** message sent from the **EAGLE 5 ISS** node and a **TFC** message returned from the point of congestion, is supposed to occur if the congestion does not abate. However, if the **EAGLE 5 ISS** node can not be reached from the point of congestion, the **TFC** response may not reach its destination.

The **IPGWx** Congestion Enhancement feature replaces the point code of the **EAGLE 5 ISS** with the point code of the **IPGWx**-connected endpoint in the originating point code subfield of the **RCT**. This replacement causes the **IPGWx**-connected endpoint to appear to be the originator of the **RCT**: therefore, the **TFC** can be routed to the **IPGWx**-connected endpoint instead of to the **EAGLE 5 ISS** since the **EAGLE 5 ISS** may not be reachable from the congested node.

Hardware Requirements

The **IPGWx** Congestion Enhancement feature has no hardware requirements.

Limitations

The **IPGWx** Congestion Enhancement feature has no limitations.

3.143 IPGWx Data Feed (Release 35.0)

Description

The IPGWx Data Feed feature provides EAGLE 5 ISS support for use of the Integrated Message Feeder (IMF) platform to monitor link status, link states, and MSU traffic on high-speed IPGWx links for the M3UA protocol.



Note:

Release 35.0 supports the IPGWx Data Feed feature only on SSEDCCM cards. Release 35.1 will include support for the IPGWx Data Feed feature on E5-ENET cards.

EAGLE 5 ISS supports sending the following data to the IMF for the IPGWx cards:

- Association configuration/status/alarms
- Link configuration/status/alarms
- Card configuration/status/alarms

Ethernet traffic originating from IPGWx cards is routed through the STC cards, which provide IP connectivity to the IMF platform. Broadcasts sent out by the LIM card are forwarded to both networks through a task on the STC card.

TCP/IP traffic originating from the IPGWx cards is routed to the correct IMF based on the routing table setup. Alarms needed by the IMF that cannot be provided by the LIM cards are sent from the OAM to the IMF by an alarm task on the STC cards.

The IPGWx application on the EAGLE 5 ISS sends signaling message content to the IMF. The content of the signaling message includes the entire M3UA packet.

IPGWx cards create one per card and send link status on that card over that EMP session. The IPGWx GPL TVG functionality routes link events to the IMF. EMP functionality transmits

link-copied MSU traffic, events and states between the EAGLE 5 ISS and the IMF. Event Time stamping allows the IMF to align link events.

The following link state changes are reported to IMF in real time by M3UA/SCTP based IPGWx links:

- OOS (Out Of Service)
- IS-NR (In Service Normal)
- Deactivating

A DPL software module provides IP connectivity over IMT. IPGWx cards send link events and copied MSU traffic to the IMFs via a TCP/IP connection over the IMT bus through the STC IP router cards.

The IPGWx Data Feed feature requires the EAGLE 5 Integrated Monitoring (E5IS) and the Time Slot Counter Synchronization (TSCSYNC) feature bits to be turned on.

Hardware Requirements

The IPGWx Data Feed feature has the following hardware requirements:

- HIPR cards must be installed in the same shelf as the IPGWx card.
- STC cards must be installed in the same shelf as each IPGWx card being monitored. A minimum of two STC cards is required per system.

 **Note:**

A sufficient number of STC cards to accommodate the number of IP links with data feed is required for your system. Contact your Sales Representative to determine the number of cards you will need.

- The K6-III version of SSEDCCM (870-2372-01) cards or higher performance hardware is required for the IPGWx cards.

Limitations

The IPGWx Data Feed feature has the following limitations:

- EAGLE 5 ISS does not allow integrated monitoring of traffic on the TALI connections. It sends all configuration/status/alarms data and signaling traffic for all monitored SIGTRAN connections. The presence of TALI connections does not prevent the SIGTRAN connections from being monitored.
- Dual slot DCM (870-1945-xx) and the K6-II variant of SSEDCCM cards (870-2508-01) are not supported.
- The number of IPGWx cards supported in an EIS environment depends on the limitation factor driven by platform and IMF subsystem.
- In the following situations, event or alarm data is lost between the EAGLE 5 ISS and the IMF:
 - If the TCP connection between an IPGWx card and the IMF subsystem becomes inoperable, data is lost until another TCP session can be established.
 - Temporary loss of data sent to the IMF can occur when an IPGW becomes congested. If the IPGWx card becomes congested to the point that signaling

traffic loss is likely, the IMF application is deactivated and MSUs are not copied to the IMF. When congestion has abated, the IMF application is resumed.

- During LIM card initialization, links are brought up and transmission of EAGLE 5 ISS traffic begins. Subsequently, a TCP session is established with the IMF subsystem. Between the start of EAGLE 5 ISS traffic and the establishment of a TCP session, link events and states are not sent to the IMF.

3.144 IPGWx Data Feed (Release 35.1)

Description

The IPGWx Data Feed feature enhances the **IPGWX** Data Feed feature from Release 35.0 by adding **EAGLE 5 ISS** support for use of the Integrated Message Feeder (**IMF**) platform to monitor link status, link states, and **MSU** traffic on high-speed **IPGWx** links for the **M3UA** and **SUA** protocols on **E5-ENET** cards.

Other than support for the **E5-ENET** card and the hardware requirement shown below, the **IPGWx** Data Feed feature is not changed from Release 35.0. For a detailed discussion of the **IPGWx** Data Feed feature, refer to the **EAGLE 5 ISS** Release 35.0 Feature Notice.

Hardware Requirements

The **IPGWx** Data Feed feature has the following hardware requirements:

- **IMF 2.1** platform
- When monitoring **IP** links on **IPGW** cards, all **STC** cards must be **SSEDCM** cards. Dual-slot cards are not supported.

3.145 IPGWx TPS Control (Release 31.6)

Beginning with this feature, the **IPGWx IP** Signaling **TPS** is a true system key, and can be enabled for a quantity up to 112,000 **TPS**. A portion of the system **IPGWx IP** Signaling **TPS** can be assigned to each linkset in the system; the total **IP TPS** sum across all linksets cannot exceed the enabled system **IPGWx IP** Signaling **TPS**.

Temporary keys will no longer be supported for **IPGWx IP TPS**. Instead, appropriate alarms are generated when system **IP TPS** exceeds a configurable threshold.

A true system **IPGWx IP** Signaling **TPS** maximum quantity is implemented in the system. A default of 200 **TPS** is provided with no **IP** Signaling **TPS** quantity feature access key enabled. **IP** Signaling **TPS** up to 112,000 can be enabled with a quantity **Feature Access Key**.

A portion of the system maximum **IP TPS** can be assigned to each linkset in the system. The total **IP TPS** assigned to all linksets cannot exceed the enabled system maximum quantity.

Alarm thresholds can be defined to display a warning when the system **IP TPS** approaches the enabled maximum, when a linkset approaches its assigned maximum, and when a link approaches its “fair share” of the **TPS** assigned to its linkset.

3.146 IPLIM Protocol Support Enhancement (Release 28.1) (IP⁷ Release 6.0)

Description

Customers require **IETF** protocol-based **A-Link** capacity up to 30,000 **TPS** between **PSTN** network elements and **IP** network elements. In addition, the customer requires that the data link layer protocols used to communicate with the **IP** network element be **M3UA/SCTP/IP**. Current releases of Tekelec **IP⁷** Secure Gateway applications do not provide features supporting these requirements.

In this feature, the **IPLIMx GPLs** have been enhanced to provide for **M3UA/SCTP/IP** connections, in addition to the present **MTP3/SAAL/TALI/TCP/IP** connections. Its rated capacity has been increased from 2000 **TPS** to 3000 **TPS**.

Each **IPLIMx IP** network connection is an **SS7** signaling link. Sixteen of these links can be assigned to a linkset, yielding a theoretical total **TPS** of 48K. Currently, the maximum **TPS** limit is 30,000. The link can also be made a part of a combined linkset. With this feature, full support is provided for **M3UA** encodings and decodings; only a subset of the **M3UA** procedures, however, is supported. **M3UA** Internet draft v12 is implemented.

Due to the nature of the **M3UA/SCTP** protocols, links using this type of connection have fewer **MTP2** features than those using **SAAL/TALI/TCP**. The resulting **IPLIMx GPL** supports **DPC-SLS** routing, but not **SI** or **CIC** routing.

Hardware Requirements

This feature requires a **SSEDCM** (Single Slot Enhanced **DCM**).

Limitations

This feature reflects a partial implementation of the **M3UA** draft specification. All **M3UA** Internet draft v12 encodings and decodings are supported. A subset of the **M3UA** Internet draft v12 procedures is supported.

3.147 IPLIMx Data Feed (Release 35.0)

Description

The **IPLIMx Data Feed** feature provides **EAGLE 5 ISS** support for use of the Integrated Message Feeder (**IMF**) platform to monitor link status, link states, and **MSU** traffic on high-speed **IPLIMx** links for the **M2PA** protocol.

Note:

Release 35.0 supports the **IPLIMx Data Feed** feature only on **SSEDCM** cards. Release 35.1 will include support for the **IPLIMx Data Feed** feature on **E5-ENET** cards.

EAGLE 5 ISS supports sending the following data to the **IMF** for the **IPLIMx** cards:

- Association configuration/status/alarms
- Link configuration/status/alarms
- Card configuration/status/alarms

Ethernet traffic originating from IPLIMx cards is routed through the STC cards, which provide IP connectivity to the IMF platform. Broadcasts sent out by the IPLIMx card are forwarded to both networks through a task on the STC card.

TCP/IP traffic originating from the IPLIMx cards is routed to the correct IMF based on the routing table setup. Alarms needed by the IMF that cannot be provided by the LIM cards are sent from the OAM to the IMF by an alarm task on the STCs cards.

The IPLIMx application on the EAGLE 5 ISS sends signaling message content to the IMF. The content of the signaling message includes the entire M2PA packet. EAGLE 5 ISS forwards an indicator to the IMF every time the M2PA proving process takes place on each association. The indicator can be a message exchanged during the proving process or an event message.

IPLIMx cards create an EAGLE Monitoring Protocol (EMP) session per associated link and send copied MSU traffic, link status, and events on each session that pertains to the associated link.

The following M2PA/SCTP Link Status Messages are reported to the IMF in real time for each direction of each IPLIMx high speed link:

- Link Status Alignment (LSA) Rx/Tx
- Link Status Proving Normal (LSPN) Rx/Tx
- Link Status Proving Emergency (LSPE) – Rx/Tx
- Link Status Ready (LSR) – Rx/Tx
- Link Processor Outage (LPO)- Rx/Tx
- Link Processor Outage Ended (LPOE) Rx/Tx
- Link Status Busy (LSB) Rx/Tx
- Link Status Busy Ended (LSBE)- Rx/Tx
- Link Status out of Service (LSO) – Rx/Tx

A DPL software module provides IP connectivity over IMT. The IPLIMx cards send link events and copied MSU traffic to the IMFs via a TCP/IP connection over the IMT bus through the STC IP cards.

The IPGWx GPL TVG function routes link events to the IMF.

The EMP function transmits link-copied MSU traffic, events, and states between the EAGLE 5 ISS and the IMF.

Event Time stamping allows the IMF to align link events.

The IPLIMx Data Feed feature requires the EAGLE Integrated Monitoring (ESIS) and the Time Slot Counter Synchronization (TSCSYNC) feature bits to be turned on.

Hardware Requirements

The IPLIMx Data Feed feature has the following hardware requirements:

- HIPR cards must be installed in the same shelf as the IPLIMx card.

- STC cards must be installed in the same shelf as the IPLIMx cards being monitored. A minimum of two STC cards is required per system.

 **Note:**

A sufficient number of STC cards to accommodate the number of IP links with data feed is required for your system. Contact your Sales Representative to determine the number of cards you will need.

- The K6-III version of SSEDCEM (870-2372-01) cards or higher performance hardware is required for the IPLIMx cards.

Limitations

The IPLIMx Data Feed feature has the following limitations:

- EAGLE 5 ISS does not allow integrated monitoring of traffic on the TALI connections. It sends all configuration/status/alarms data and signaling traffic for all monitored SIGTRAN connections. The presence of TALI connections does not prevent the SIGTRAN connections from being monitored.
- Dual slot DCM (870-1945-xx) and K6-II variant of SSEDCEM cards (870-2508-01) are not supported.
- The number of IPLIMx cards supported in an EIS environment depends on the limitation factor driven by platform and IMF subsystem.
- In the following situations, event or alarm data is lost between the EAGLE 5 ISS and the IMF:
 - If the TCP connection between an IPLIMx card and the IMF subsystem becomes inoperable, data is lost until another TCP session can be established.
 - Temporary loss of data sent to the IMF can occur when an IPLIMx card becomes congested. If the IPLIMx card becomes congested to the point that signaling traffic loss is likely, the EAGLE 5 ISS/IMF application is deactivated and MSUs are not copied to the IMF. When congestion has abated, the EAGLE/IMF application is resumed.
 - During LIM card initialization, the links are brought up, and transmission of EAGLE 5 ISS traffic begins. Subsequently, a TCP session is established with the IMF subsystem. During the time from the start of EAGLE 5 ISS traffic to the establishment of a TCP session, link events and states are not sent to the IMF.

3.148 IPLIMx to 8 Points (Release 29.1) (IP7 Release 7.1)

Description

The **IPLIMx** to 8 Point feature expands the capability of the Multipoint **IPLIMx** feature to support not just two, but eight **IPLIMx** signaling links on a **SSEDCEM**. This feature reduces the number of **SSEDCEM** cards required to provide a given number of **IPLIMx** signaling links. **ANSI** and **ITU** are supported by this feature.

The following figure illustrates the configuration supported by the **IPLIMx** to 8 Point feature. With this configuration 8 **IP** connections use the "A" and "B" interface. The

socket/port identifier names are consistent with the naming convention used for Multi Port LIM. Any signaling link can use either Ethernet interface A or interface B.

Figure 3-10 IPLIMx to 8 Point Connectivity (8 Signaling Links)

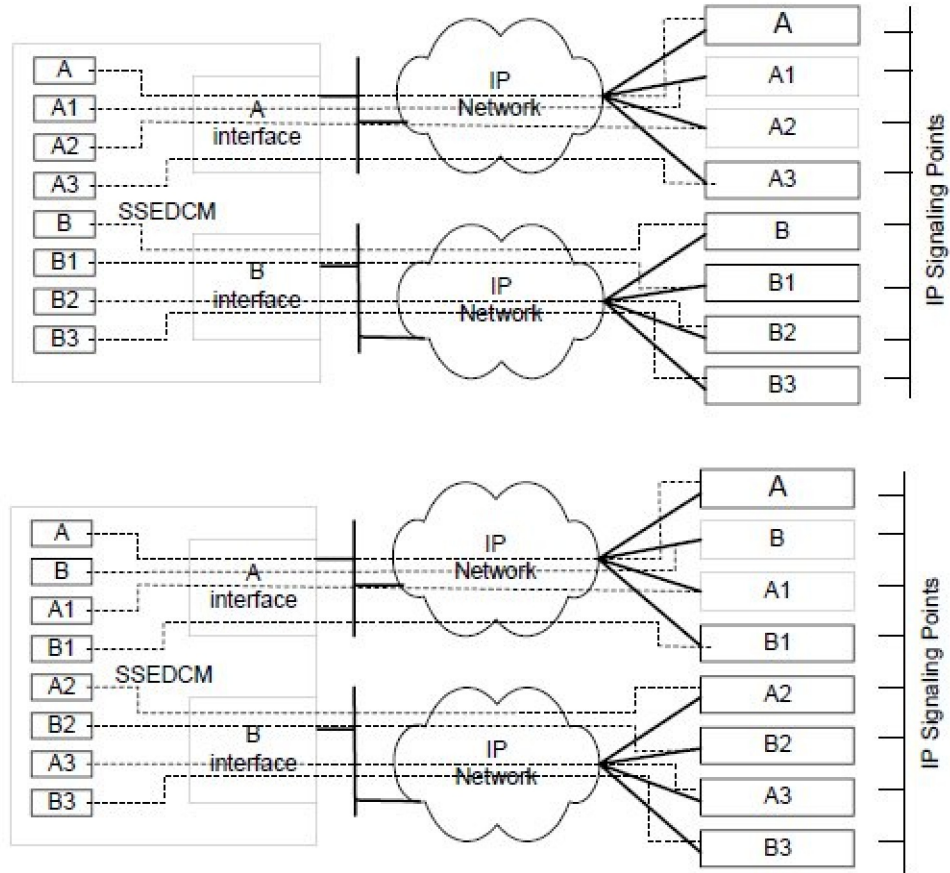

Hardware Requirements

This feature requires the Single Slot **EDCM** (870-2372-01).

3.149 IPLIMx/IPGWx on EPM (E5-ENET Card) (Release 35.0)

Description

The IPLIMx/IPGWx on EPM feature provides a single-slot E5-ENET card with increased TPS capacity relative to existing SSEDCCM cards.

Note:

IP links can be assigned to cards in Release 35.0. However, Release 35.0 does not support data feed to the IMF on the E5-ENET card. Data feed to the IMF for IP links is supported on the SSEDCCM cards for Release 35.0. Release 35.1 will provide support for data feed to the IMF on both SSEDCCM and E5-ENET cards.

The E5-ENET card allows 16 links for IPLIMx. For IPGWx, the E5-ENET card allows 50 connections and 1 signaling link.

Table 3-21 IPLIMx/IPGWx on EPM

Card	IPLIMx		IPGWx	
	Max No. of Signaling Links	Link designations	Max No. of Signaling Links	Max No. of IP Connections
E5-ENET	16	a..a7, b..b7	1	50
DCM	2	a, b	1	50
SSEDCM	8	a..a3, b..b3	1	50

The E5-ENET card supports the SCTP and M2PA protocols for IPLIMx and the SCTP and M3UA protocols for IPGWx.

The E5-ENET card uses a Celeron-M processor and does not require a fan tray or any additional power requirements; however, it does require thermal monitoring, which is provided.

The maximum number of cards per system is 100 for IPLIMx and 64 for IPGWx.

Two new GPLs support the IPLIMx/IPGWx applications: IPLHC for IPLIMx applications and IPGHC for IPGWx applications.

New Concepts

The IPLIMx/IPGWx on EPM feature introduces or enhances the following concepts:

- Configurable SCTP Buffers
- Increased TPS
- Ethernet Interfaces
- Thermal Monitoring

Configurable SCTP Buffers

The IPLIMx/IPGWx on EPM feature allows SCTP buffers to be configured for a connection. These buffers allow users to maximize memory used based on traffic rate. Hardcoded minimum and maximum values are used for range checking. If a value outside this range is configured, the command is rejected.

Auto-inhibit is invoked if more SCTP buffers are configured than the card can handle. Because there is a finite amount of memory available, SCTP buffering is a function of TPS, network round trip time (RTT), and number of connections or links.

Increased TPS

The E5-ENET card capacity is increased. For the IPHLC and IPGHC GPLs, each link can carry up to card capacity. Thus, buffer sizing and congestion thresholds are adjusted for the card maximum and link maximum.

For both IPGHC and IPLHC, the increase in traffic impacts system and network design. There can be 100 IPLIMx and 64 IPGWx cards in a system.

Ethernet Interfaces

Each interface is independent of the other and supports 10/100 Mbps data rates, full/half duplex, fixed/auto-negotiate, DIX/802.3 MAC header modes. Although each Ethernet PMC card has two Ethernet interfaces, for this feature, only one on each card is used. With the current hardware configuration two PMC cards are required to allow port A and port B interface operation.

The E5-ENET card requires adapters for connection to either dual RJ-45 jacks or DB26 (female connector).

Thermal Monitoring

The E5-ENET card requires thermal monitoring. The card processor can overheat from high ambient temperature or air flow blockage. If the junction temperature goes above operating limits (approximately 125°C), the CPU halts and the card shuts itself down to prevent permanent, catastrophic damage. If thermal shutdown occurs, all processor activity ceases.

To prevent thermal shutdown from occurring, a series of alarms are used to detect and notify users of increasing thermal conditions.

When the CPU temperature exceeds a configurable thermal threshold (Temperature Level 1, 56°C - 92°C [133°F - 198°F]), a major alarm is raised against the card. If the temperature exceeds a second thermal threshold (Temperature Level 2, 60°C - 99°C [140°F - 210°F]), a critical alarm is raised against the card.

When the second thermal event occurs, the application receives a notification from the OS and begins redirecting traffic to other cards if possible. For IPLIMx all links on the card go out of service. For IPGWx, the link is taken out of service and the far end is notified that the connections no longer accept traffic.

Once the temperature returns to below the Temperature Level 2 threshold, the LPO condition is cleared and links can begin operation again. When the temperature returns to below Temperature Level 1, a clearing alarm is raised for the card.

Hardware Requirements

The IPLIMx/IPGWx on EPM feature has the following hardware requirements:

- A HIPR card must be installed on each shelf that contains E5-ENET cards.
- An adapter per Ethernet port

Limitations

The IPLIMx/IPGWx on EPM feature has the following limitations:

- An E5-ENET card cannot support the IPLIMx and IPGWx functions simultaneously
- The number of IPLIMx cards supported in an EIS environment depends on the limitation factor driven by platform and IMF subsystem.
- There is a minimum and maximum SCTP buffer configuration per connection (8192 bytes and 3.125 Mbytes, respectively). The card maximum is 3.125 Mbytes: therefore, if a connection has the maximum buffer configuration, there can be only 1 connection on the card.

3.150 IPLIMx/IPGWx on EPM (Release 35.1)

Description

The IPLIMx/IPGWx on EPM feature enhances the **IPLIM/IPGWx on EPM** feature from Release 35.0 by adding **EAGLE 5 ISS** support for the **SUA** protocol on **E5-ENET** cards.

Other than the added support and the limitations shown below, the **IPLIMx/IPGWx on EPM** feature is not changed from Release 35.0. Refer to the **EAGLE 5 ISS 35.0** Feature Notice for a detailed discussion of the **IPLIMx/IPGWx on EPM** feature.

Limitations

The **IPLIMx/IPGWx on EPM** feature has the following limitations:

- **E5-ENET** cards cannot be deployed in a mixed linkset with **DCM** cards.
- The maximum number of **E5-ENET**, **DCM**, and/or **SSEDCM IPLIMx** and **IPGWx** cards in a system is 164. The mixture of these cards is a maximum of 100 cards for **IPLIMx** and 64 cards for **IPGWx** in any combination. However, due to the increased throughput of the **E5-ENET** card, the **IMT** system capacity has a limit of 100 **E5-ENET IPLIMx** and **IPGWx** cards in any combination.

3.151 IPMX/MCAP/TDM Replacement (EAGLE Release 30.0/IP7 Secure Gateway Release 8.0)

Overview

Beginning in **EAGLE** Release 30.0, the **IPMX**, **MCAP-256** and **TDM*** (*all versions earlier than -10) cards are obsolete. Any **EAGLE** or **EAGLE 5** customer upgrading to Release 30.0 must replace all **IPMX** cards with **HMUX** cards (870-1965-01), all **MCAP-256** cards in slots 1113 and 1115 (the former **MCAP** slots) with **GPSM-II** cards (870-2360-01), and any **TDM** card of a version earlier than -10 with **TDM-10** (or later) cards (870-0774-10).

Replacement of the -05 backplane also is required, as this backplane does not support **HMUX**.

Note:

These hardware upgrades must be performed prior to the software upgrade. After the upgrade to Release 30.0 has been completed, an **MCAP** card will not be allowed to boot in the system. Only a **GPSM-II** card will be allowed in the former **MCAP** slots.

HMUX

The **High-Speed Multiplexer (HMUX)** is baseline hardware for **IP7** Secure Gateway Release 8.0. It replaces the obsolete **IPMX** card, and increases the number of links supported by the **IP7** Secure Gateway in a future release. The **HMUX** enhances the

IMT bus by introducing a new 1Gb/sec inter-shelf bus bandwidth. (The intra-shelf bus data rate remains the same at 125Mb/sec.)

HMUX also enhances **IMT** performance by transmitting data between shelves only when it is necessary. Traffic between **IP7SG** cards on the same shelf is allowed to stay on the shelf **IMT**, and is not required to transit between shelves. Traffic between shelves is not required to pass onto an intra-shelf **IMT** bus, if this is not necessary.

GPSM-II for MCAP Slots

Future applications and table expansions will require increased performance across the **IMT** bus interface both to and from the **Maintenance and Administration Subsystem**. To meet this need, the **GPSM-II** incorporates an **EDCM**-based design for the **OAM** functionality on the **IP7** Secure Gateway. There is also a need to increase available memory and performance on the **OAM** for these applications and for future use.

The **GPSM-II** utilizes a 1GB memory daughterboard.

3.152 IP-SCP with LNP Capability (IP7Releases 1.0, 2.0)

This feature, which was available only in a laboratory environment in release 1.0, allows the **IP7** Secure Gateway to act as an **IP-SCP**. The **SCCP/TCAP** queries are received and responses returned over an **IP** interface.

Figure 3-11 IP Connected LNP Application (Lab Only)

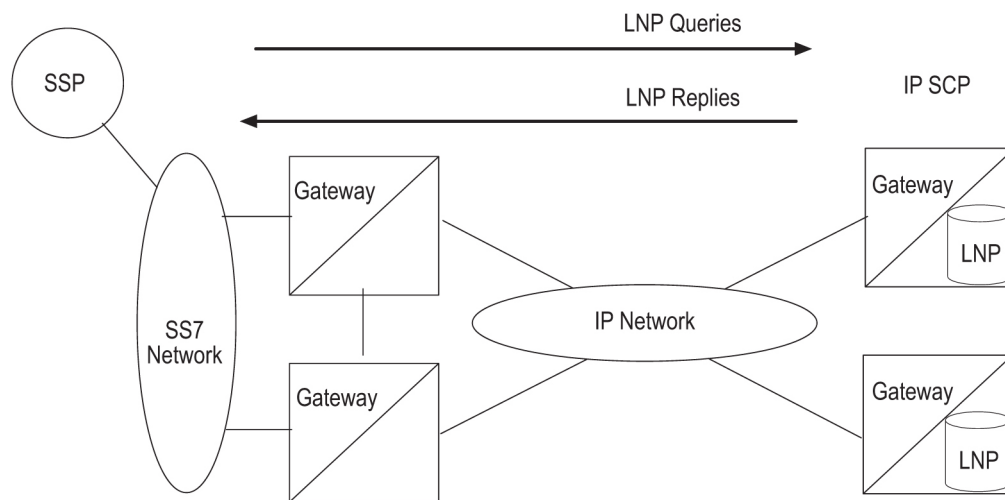

3.153 IPS Application on E5-ENET-B (Release 44.0)

The **E5-ENET-B (Release 44.0)** card can run the **IPS** application. The card is provisioned using the `ent-card` command with `type=ipsm` and `appl=ips`.

3.153.1 Feature Control Requirements

The **Fan** feature must be turned on before an **E5-ENET-B** card running the **IPS** application can be brought into service.

If the Fan feature is turned on, then E5-ENET-B cards running the IPS application can co-exist with and be used to replace DSM-1G (Part Numbers 870-2371-XX) and E5-IPSM (Part Numbers 870-2877-XX) cards without configuration changes. If the Fan feature is off, then the E5-ENET-B cards will auto-inhibit.

3.154 IPS GPL on E5 Assembly (Release 37.5)

The IPS GPL on E5 Assembly feature supports the **ips** application on the E5-IPSM card, in addition to the current implementation on the DSM-1G card.

The E5-IPSM card runs the **ipshc** GPL, which supports the **ips** application.

Thermal management and alarming provisions are provided for the E5-IPSM card.

3.154.1 Feature Control Requirements

There are no feature control requirements identified for this feature.

3.154.2 Hardware Requirements

The IPS GPL on E5 Assembly feature has the following hardware requirements:

- Two **HIPR** cards must be installed on each shelf where an E5-IPSM card is installed.
- A maximum of 3 E5-IPSM cards, IPSM cards, or a combination of both cards is supported for a single EAGLE 5 ISS node, on any shelf or combination of shelves.
- Backplane cable adaptors

3.154.3 Limitations

The IPS GPL on E5 Assembly feature has the following limitations:

- The E5-IPSM card does not preserve memory across card boots: therefore, the application does not remain intact across card boots.
- The E5-IPSM card does not have persistent memory; therefore, SSH keys must be regenerated on every reboot.

3.155 IPv6 support on EPAP (Release 16.1)

The Oracle Communications EAGLE Application Processor (EPAP) IPv6 Support on EPAP feature allows the EPAP application to support IPv6 on interfaces connecting a customer provisioning interface, SSH, GUI, Query server, NTP and EMS. EPAP supports IPv4 and IPv6 data. As IPv4 and IPv6 data may be mixed, implementation is dual stack compliant.

EPAP is able to support both IPv4 and IPv6 traffic simultaneously (dual stack). The following use cases should be considered in support of IPv6:

- A new installation in an IPv6-only Network
- Adding a IPv6 cards to an existing EAGLE supporting IPv4 Networks
- Migration of IPv4 deployments to an IPv6-only Network

See *Administration Guide* for more information on IPv4 and IPv6 address support.

3.155.1 Hardware

The IPv6 support on EPAP feature is supported on the E5-APP-B card.

3.156 IS41 GSM Migration (Release 36.0)

Description

The IS41 GSM Migration (IGSM) feature is an enhancement to the original **IS-41 to GSM** Migration feature, to add **GSM to IS-41** migration functions to the existing **IS-41 to GSM** migration support of call termination for customers in migration from **IS-41 to GSM** wireless technology. This enhancement adds flexibility in **LOCREQ** message decoding and encoding for number migration from one mobile protocol to another to the existing support of **Loc_Req**, **MSRCV GSM SRI**, and **SRI_SM** operation code processing.

The original **IS-41 to GSM** Migration feature functions support call termination for customers in migration from **IS-41 to GSM** wireless technology. The feature gives the wireless service provider a way to begin the migration of mobile subscribers from **IS-41 to GSM**, while allowing each subscriber to retain his or her existing phone number. The feature allows termination of calls to either an **IS-41** handset or a **GSM** handset, based on the provisioned migration status of the subscriber.

The enhancement separates the **IS41 GSM Migration** feature from the **G-Port** feature. The **IS41 GSM Migration** feature can exist as a standalone feature without depending on the **G-Port** feature. When the **IS41 GSM Migration** feature is on, the **MNP** service selector is used instead of the **GPORT** service selector.

The **IS41 GSM Migration** feature uses the **EPAP (EAGLE Provisioning Application Processor) RTDB** to retrieve the subscriber portability status and provision directory numbers for exported and imported **IS-41** subscribers. This database maintains information related to subscriber portability in the international E.164 format.

The **IS41 GSM Migration** feature supports both **GT-** and **MTP-**routed messages.

- **GT-**routed messages support **UDT** and non-segmented **XUDT** message types and perform service selector lookup after **SCCP** verification.
- **A-Port** processes **MTP-**routed messages if the **MTP Messages for SCCP Applications (MTP Msgs for SCCP Apps)** feature is turned on.

The **IS41 GSM Migration** feature adds processing of **LOCREQ** and **SMSREQ** messages to the **SRI** and **SRI_SM** message processing provided by the original **IS-41 to GSM** Migration feature.

- An **ANSI-41 LOCREQ** message is initiated by a **TDMA/CDMA MSC** that queries the **HLR** for information regarding user subscription/location before terminating a voice call.
- An **ANSI-41 SMSREQ** message is initiated by a **TDMA/CDMA SMSC** that queries the **HLR** for information regarding user subscription/current location before delivering a short message.

If a data entry matching the conditioned Called Party is found and an **NE** (either **RN** or **SP**) is assigned to the entry, the **EAGLE 5 ISS** processes the **SRI**, **SRI_SM**, **LOCREQ**, and **SMSREQ** message based on the **NE/PT** value assigned.

If a HomeRN is detected in the Called Party and a matching **DN** with **RN** is found in the database, the **EAGLE 5 ISS** generates **UIM 1256**, indicating detection of circular routing, and routes the message using normal routing if both the **MNP Circular Route Prevention** feature and the **IS41 GSM Migration** feature are turned on.

If an undefined **TCAP** portion (not **ITU** or **ANSI**) is received by the **IS41 GSM Migration** feature, the message falls through to **GTT**.

New GSM2IS41 Prefix

The **EAGLE 5 ISS** populates a new following the same mechanism that is used for the existing **IS412GSM** prefix. The **EAGLE 5 ISS** returns a **GSM2IS41** prefix in the **SRI_ACK** message if a received **SRI** message is destined for a non-migrated **IS41** or **GSM** migrated **IS41** subscriber (a data entry is found with **RN** and **PT=0**).

The MIGRPFIX Option

The **MIGRPFIX** field in the `rtrv-gsmopts` command output is shown as **MULTIPLE** (for **ON**) or **SINGLE** (for **OFF** or disabled). If **MIGRPFIX = MULTIPLE**, the **RN** from the **RTDB** is used as the prefix in the **SRI_ACK** message. If **MIGRPFIX=SINGLE** (disabled) and the **GSM2IS41** prefix is **NONE**, the **SRI** message issues **UIM 1341** “**SRI rcvd GSM2is41 prefix not provisioned**” and the message falls through to **GTT**.

For systems that are upgraded to the **IS41 GSM Migration** feature, the upgrade process sets the **MIGRPFIX** option to **ON** if the **G-Port** feature is turned on and the **IS412GSM** prefix is defined. If the **G-Port** feature is turned on and the **IS412GSM** prefix is not defined, the upgrade process sets the the to **OFF**. The default setting for new systems is **OFF** (disabled).

Service State and Re-Route

The **IS41 GSM Migration** feature shares the service state and re-route with the **A-Port** and **G-Port** features, under one service called the **MNP Service** state. (The **G-Port** service state is used if only the **G-Port** feature is on.) The **IS41 GSM Migration** feature supports re-route functions as part of **MNP** service re-route. Alternate **PCs** are shared by all three features.

Alarms and the `rept-stat-sccp` command output show **MNP Service** information if the the **IS41 GSM Migration** feature is enabled.

Database Lookup and Routing

The **MSISDN** is used for **RTDB** database lookup.

- The **IS41 GSM Migration** feature performs **RTDB** lookup on the conditioned number, and routes or relays the message based on the lookup result.
- The individual number database is searched first.
- If the number is not found, the number range database is searched.
- If a match is not found in the individual and range based databases, **GTT** is performed on the message.
- When **MSISDN** numbers in the **RTDB** database are odd, the **CDPA GTI** of the incoming message is 2, and the last digit of the number is ‘zero’, database lookup is performed once using the even number. If no match is found, database lookup is performed using the odd number (without the last digit).
- For **LOCREQ** messages, the **DN** is derived based on the setting of the **LOCREQDN** option (see the new `chg-is41opts` command).

- For non-**LOCREQ** messages, the **DN** is derived from the **SCCP** portion of the message.
- Upon successful decode and verification of the message, number conditioning is performed. The **DN** or **SCCP CDPA** digits might need to be conditioned to international number format based on the service nature of address (**SNAI** or **TCAPSNAI** or **MTPLOCREQNAI**). HomeRN and **IEC** or **NEC** prefixes are removed. The **IS41 GSM Migration** feature performs **RTDB** lookup on the conditioned number, and routes or relays the message based on the lookup result.
- An **SMSREQ** message is relayed like any other non-**LOCREQ** message. No changes are performed to the **TCAP/MAP** portion of the message. If the general **TCAP/MAP** verification is successful, the **TCAP** opcode is **SMSREQ**, and the **IS41GSM** option **SMSREQBYPASS** is **YES** (see the **-is41gsm** commands), the message is processed as an **SMSREQ** message. Otherwise, message relay is performed using **SCCP CDPA** information.
- The **IS41 GSM Migration** feature modifies the **TCAP** information for **LOCREQ** messages only when a HomeRN was deleted from the **TCAP DN** and **LOCREQRMHRN = YES**. Any gaps in the data caused by a change in field length will be resolved by shifting the remaining information up. Any **IEC** or **NEC** code is left.
- The **IS41 GSM Migration** feature falls through to **GTT** if number conditioning fails or does not find the **DN** in the **RTDB** database, or the **DN** is found with non-**A-Port** data.
- If a HomeRN is detected in the Called Party and a matching **DN** with **RN** is found in the database, the **EAGLE 5 ISS** generates **UIM 1256**, indicating detection of circular routing, and routes the message using normal routing if both the **MNP Circular Route Prevention** feature and the **IS41 GSM Migration** feature are turned on.

NOTE: Normal routing is performing **GTT** if the incoming message is sent to the **EAGLE 5 ISS Self Point Code**. Normal routing is routing the message to the **MTP DPC** if the incoming message is **MTP**-routed (the **MTP DPC** of the message is not the **EAGLE 5 ISS Self Point Code**).

- If the **IS-41** message is **LOC_REQ** and the **MIN** parameter has unsupported values (**MIN** digits < 5 or >15), a **LOC_REQ** Return Error response message with error code information element as 'unexpected data value' is returned.
- If the **IS-41** message is **SMS_Request** and the **CDPA** digits in the **RTDB** are associated with a portability type of 5 (Migrated), an **SMS_Request** Response with **SMS Access Denied Reason = 5** is returned.
- If the **GSM** message is **SRI-SM**, the **CDPA** digits in the **RTDB** are associated with "**RN**" Entity type, and the portability type is "not known to be ported", an **SRI-SM RETURN ERROR** message with Error Code "Unknown Subscriber" is returned.

Measurements

The following enhancements support the collection and retrieval of measurements related to the **IS41 GSM Migration** feature. These new measurement registers are supported with and without the Measurements Platform feature enabled.

- New registers are added to the **NP SYS** reports: Hourly Maintenance Measurements on **NP System (MTCH-NP)** and Daily Maintenance Measurements on **NP System (MTCD-NP)**.
 - **APSMSRCV**—Number of **SMS** Request messages received
 - **APSMSREL**—Number of **SMS** Request messages relayed
- New registers are added to the **NP SSP** reports: Hourly Maintenance Measurements on **NP SSP (MTCH-SSP)** and Daily Maintenance Measurements on **NP SSP (MTCD-SSP)**.

- **APLRACK**—Number of call related **LOCREQ** messages acknowledged.
- **APLRRLY**—Number of call related **LOCREQ** messages relayed.
- **APNOCL**—Number of non-call non-**LOCREQ** related messages relayed.
- **APNOCLGT**—Number of non-call Non-**LOCREQ** related messages that fell through to **GTT**.

Feature Access Key

A feature access key (**FAK**) for part number 893017301 is required to enable the **IS41 GSM Migration** feature.

- The **GTT** feature must be on before the **IS41 GSM Migration** feature can be enabled.
- After the feature is enabled and turned on, it cannot be turned off.
- No temporary **FAK** is allowed for the feature.
- An **LNP** quantity feature and the **IS41 GSM Migration** feature cannot be enabled in the system at the same time.

Hardware Requirements

The **IS41 GSM Migration** feature has the following hardware requirements:

- **DSM** cards with at least 4G of memory
- The **IS41 GSM Migration** feature cannot be enabled if any **DSM** cards with less than 4G of memory or any **TSM** cards for **SCCP** are present in the system. When **IS41 GSM Migration** is enabled, no **DSM** cards with less than 4G of memory and no **TSM** cards for **SCCP** can be provisioned.

Limitations

None

3.157 IS41 GSM Migration Support for Relaying SRI_SM to Default SMSC (Release 41.1)

When an SRI_SM message is received for an own-network IS41 subscriber (NE=RN, PT=0), a configuration option specifies whether IGM responds with a Return Error message (existing function) or relays the SRI_SM message to the default IS41 Short Message Service Center (SMSC).

The IGM enhancement to relay an SRI_SM to a specified default SMSC is available if the IS41 GSM Migration feature (IGM) is on. The enhancement provides the following new GSMSMSOPTS configuration options:

- **IGMSMSRELAY**— Select the existing function to send an SRI_SM with "unknown subscriber", or the new function to relay an SRI_SM to the default SMSC.
- **DEFIS41SMSC**—Specify the default SMSC address.
- **IS41SMSCGTTSN**—Specify the GTTSET where the translation for the default SMSC address is configured

If **IGMSMSRELAY** is **NO**, then IGM sends a Return Error message with error reason "Unknown Subscriber".

If IGMSMSRELAY is YES, then IGM relays the SRI-SM message to the default IS41 SMSC by performing GTT translation (found in the GTTSET) on the default SMSC address digits.

3.157.1 Feature Control Requirements

The IS41 GSM Migration feature (Part Number 893-0173-01) must be turned on before the IGM Support for Relaying SRI_SM to Default SMSC functionality is available in the system.

3.157.2 Hardware Requirements

The GTT feature and all EPAP-related features where Service Portability can be performed require Service Module cards (DSM cards with at least 4G of memory, E5-SM4G cards, or a mixture of both).

3.158 IS-41 to GSM Migration (EAGLE Release 30.0/IP7 Secure Gateway Release 8.0)

The **IS-41 to GSM Migration Feature** is planned for Release 30.1. The overall purpose of this feature is to support call termination for customers in migration from **IS-41 to GSM** wireless technology. The major functional areas of the **EAGLE** that support **IS-41 to GSM Migration** are **Database Administration, Protocol, and Measurements**. This feature gives the wireless service provider a way to begin the migration of mobile subscribers from **IS-41 to GSM** while allowing those subscribers to retain their existing phone number. Once the subscriber is marked as migrated, the **GSM** handset is fully functional. This feature allows termination of calls to either an **IS-41** or **GSM** handset based on the provisioned migration status of the subscriber. The **IS-41 to GSM Migration** feature is based on the same technology as the **EAGLE's G-Port** feature. Therefore, this document refers to **G-Port** in several areas. The **IS-41 to GSM Migration** feature is implemented as an enhancement to the existing **G-Port** feature. Therefore, **IS-41 to GSM Migration** is considered and referred to as a **G-Port** feature in the current document.

3.159 ISCC Interface Loopback Test (Release 22.0)

The **ISCC Interface Loopback Test** tests the interface to **ISCC** chip. The **ISCC** chip has a local loopback mode in which the internal transmit data is tied to the internal receive data such that the data to be transmitted is actually looped back as data just received. If the test is successful, the hardware and software up to the **ISCC** chip is not the cause of the failure.

The loopback test is similar to looping back the transmit and receive interfaces by using a loopback plug on the backplane. However, the advantages of using the **ISCC** loopback test over a loopback cable are:

- loopback test is interface independent
- loopback plug will not work for **V.35** interfaces
- all hardware baselines supported
- can be done remotely
- no intrusive mechanical action on the part of the user

The disadvantages of the **ISCC** loopback test are:

- doesn't validate the other hardware components on the **SS7 LIM** card

- doesn't validate the **EAGLE** backplane

When the **ISCC** loopback test is started, the **ISCC** chip is put into the local loopback mode. The **SS7 LIM** goes through the alignment process. If the signaling link aligns, the **ISCC** chip has passed the test. The **ISCC** chip is put back to normal operation and the results are displayed to the user.

Throughout this test, the link is deactivated and not available for traffic. When the **ISCC** loopback test is running, the **SST** state of the signaling link displays the entry **LPBK** and the **AST** of the signaling link displays the entry **ISCC**. These states of the signaling link are displayed with the `rept-stat-slk` command.

Parameters

To run the **ISCC** loopback test, the `loopback` parameter has been added to the `tst-slk` command. The values of the `loopback` parameter are either `yes` or `no`.

`yes` = perform the **ISCC** loopback test

`no` = do not perform the **ISCC** loopback test (the default value)

Input/ Output Example

```
tst-slk:loc=1201:port=a:loopback=yes
```

```
RLGHNCXA03W 97-06-07 15:55:57 EST Rel 22.0.0  
2408.1078 CARD 1203,A INFO ISCC Loopback test PASSED
```

```
Report Date: 97-06-07 Time: 15:55:57
```

The **ISCC** loopback test can only test one signaling link at a time. The signaling link to be tested must be in the **OOS-MT-DSBLD** state or the test cannot be executed. If the link is still active (in the **IS-NR** state) and an attempt is made to execute the **ISCC** loopback test, the command is rejected and this message is displayed.

Error Messages

```
E2916 Cmd Rej: Link must not be active to execute loopback
```

The **ISCC** loopback test cannot be executed if the link fault sectionalization feature is running. If the link fault sectionalization feature is running and an attempt is made to execute the **ISCC** loopback test, the command is rejected and this message is displayed.

```
E2921 Cmd Rej: LFS must not be running on requested link
```

The **ISCC** loopback test only works for **SS7 LIMs**. If the signaling link selected to test is not an **SS7 LIM** and an attempt is made to execute the **ISCC** loopback test, the command is rejected and this message is displayed.

```
E2292 Cmd Rej: Card does not exist or is not a LIM (LOC)
```

No command such as `act-slk`, that would change the state of the signaling link from **OOS-MT-DSBLD**, can be executed while the **ISCC** loopback test is running.

During the **ISCC** loopback test, no level 1 information about the link is available.

The **ISCC** loopback test cannot run if the specified card is unplugged.

3.160 ISUP Message Type Screening (EAGLE Release 30.0/IP7 Secure Gateway Release 8.0)

Description

The **ISUP** Message Type Screening feature provides the **EAGLE** with the capability to screen on **ISUP** message type. This feature augments the **Gateway Screening** functionality currently provided by the **EAGLE**. The feature is based on the previous release of major enhancements to the **Gateway Screening** feature. (At that time, **ISUP** message type screening was not implemented.) The enhanced functionality of **Gateway Screening** results in a more secure, easily administered network.

Note:

The functionality provided by this feature is not controlled by feature key or **STP** option. As part of core **GWS** capability, it becomes a core component the **EAGLE STP**.

Hardware Requirements

This feature requires the hardware baseline for Release 30.0. This includes the **GPSM-II** and **TDM-10** (or later) configuration of the **MASP** (for the **EOAM GPL**), along with **ASM** cards (for the **GLS GPL**) and **LIM**, **MPLIM**, and **ASM (SCCP GPL)** cards to support screening of network protocol traffic.

GTWY Measurements

For Release 30.0, the new measurements report type **GTWY-LSONISMT** has been added. The measurements for this new report are kept on a per-link set, per- originating **NI (ANSI)**, per-**ISUP** message type basis. These measurements will be reported in the `gtwy-lsonismt_yyyymmdd_hhmm.csv` **FTP** report files (mm is a half-hour boundary).

3.161 ISUP Normalization Administration (IP⁷ Release 5.0)

Description

New “Variant” **ON/OFF** Control Features are added for all the new *Tekelec-defined* Variants in **PSTN** Category 1 that Tekelec supports. Tekelec pre-assigns the **PSTN** Presentation values associated with each of these Control Features.

New Quantity Control Features are added to allow a customer the ability to provision a specified quantity of *user-defined* Variants within the **PSTN** Categories 4096-65535. Each Quantity Control Feature is associated with a specific quantity of Variants, i.e. 1, 2, 3, ... 20-Variants. The customer can only provision as many *user-defined* Variants as was purchased.

Refer to the **Database Administration Manual - Features** for current information on this feature.

Upgrade Considerations

Feature Control Table

The size of an entry and the maximum number of entries in the **FEATCTRL.TBL** does not change. However, there are new entries for the new Controlled Features introduced by this feature. It is necessary during the upgrade process to preserve the status of the existing permanently and temporarily **ENABLED** Control Features.

ISUP Normalization Variant Table

Prior to an Upgrade from **IP7 SG** Release 4.0 to **IP7 SG** Release 5.0, **TCU** has already built four entries in the table for the four Variant databases (Q.767, **ETSIV3**, **UK**, and Germany) and set the appropriate "control_flag" in each entry. During the Upgrade procedure the **ETSIV3** Variant is preserved. The other three Variants (Q.767, **UK** and Germany) are preserved only if their associated Controlled Feature is **ENABLED**. During the Upgrade, the three Control Features are checked, and for each feature that is not **ENABLED**, its corresponding table entry is set back to default values, i.e., de-provisioned.

Limitations

There is a potential problem if Temporary Feature Keys are allowed for the Quantity Control Feature. If the temporary key expires, how are **ISUP** Variant Table entries reclaimed, and how are routing keys disabled. For example, if the feature key for 10-table-entries expired, leaving the 5-table-entries key enabled, there would be no way to know which five entries to keep. The solution is that Tekelec will not provide temporary keys for Quantity Control Features.

3.162 ISUP Normalization in the IP7 SG (IP7 Release 4.0)

This feature allows an **IP7 SG** to deliver **ISUP** messages that arrive at the **SG** from the **PSTN** in a country specific **ISUP** variant format, to an **IP** device in a normalized **ISUP** format. Likewise, it enables traffic received from an **IP** device in a normalized **ISUP** format to be delivered to a **PSTN** link in the appropriate country variant format. The normalized **ISUP** messages are carried in **TALI** packets. Data is contained in the **TALI** packet itself to specify what National network (i.e., what country) the **ISUP** message originated from or is destined to and what **ISUP** variant the original **PSTN** message was formatted in.

This feature allows an **IP** device (e.g., a **MGC** providing Class 4 Tandem functionality) connected to an **IP7 SG** to perform call setup for multiple countries without knowledge of the various countries' **ISUP** message formats. The **MGC** needs only to support encode/decode functionality for the normalized format and does not have to support encode/decode functionality for each **ISUP** variant.

Refer to the **Database Administration Manual - Features** for current information on this feature.

3.163 ISUP NP with EPAP (Releases 31.11, 34.0)

Description

The purpose of the Integrated Services Digital Network User Part Numbering Plan with EAGLE 5 SAS Provisioning Application Processor (ISUP NP with EPAP) feature is to prepend a prefix (a SubNet prefix or RN) to the CdPN of an IAM message if the CdPN is a ported in (including never been ported) or a ported out DN before relaying the message to its destination. The prefix provides the recipient switch a means to differentiate a call so that different billing rates or routing can be applied to the call.

The title is selected to distinguish a similar feature developed for support of ELAP database lookup based on the ANSI ISUP Initial Address Message (IAM). This feature presents no impact on the EPAP.

The EAGLE 5 SAS provides the "ISUP NP with EPAP" treatments to the ISUP IAMs that meet certain gateway screening criteria using the existing Gateway Screening feature. The Gateway Screening feature will allow SS7 messages to be selected for the "ISUP NP with EPAP" treatments, minimally, based on:

- OPC
- DPC
- SIO
- ISUP message type (IAM and SAM)

For the selected ISUP messages, the EAGLE 5 SAS performs NPDB lookup based on ISUP IAM CdPN (the B-number). If the CdPN is a ported out number, the EAGLE 5 SAS relays the IAM with CdPN=RN + Initial CdPN. If the CdPN is a ported-in or never been ported subscriber, the EAGLE 5 SAS prepends a SubNet prefix, that identifies the SubNet to which the CdPN belongs within the operator network, to the CdPN of the IAM message before relaying the message to its destination. For any other types of CdPN, the EAGLE 5 SAS relays the IAM without modifications. If SAM are used in the network, then SAM should be entered in the Gateway Screening rules.

Hardware Requirements

The ISUP NP with EPAP feature does not require any new hardware.

3.164 ISUP-Over-IP Gateway for Connectivity to IP-SEPs (IP⁷ Release 1.0)

This functionality allows **SS7** nodes to exchange **ISUP** protocol messages with one or more signaling end points (class 4 switches, class 5 switches, VoIP gateways, media gateway controllers (**MGCs**), or remote access servers) residing on an **IP** network. The **IP⁷** Secure Gateway node maps the originating point code, destination point code, and circuit identification code to a **TCP/IP** address and port. The **SEP** is provided the originating and destination point codes in the **MTP** level 3 routing label as part of the passed protocol.

Figure 3-12 SEP Connectivity via ISUP over IP

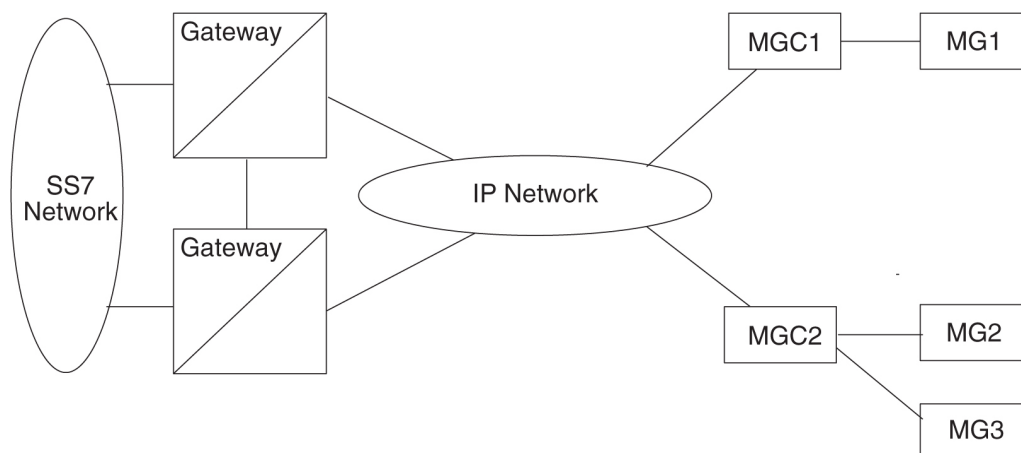

This feature provides **TCP/IP** point-to-multipoint connectivity by way of a new **GPL**, **SS7IPGW**, running on the **DCM** which, together with the hardware, provides connectivity to databases (or other switching equipment) for **SS7** devices that reside on ethernet **TCP/IP** networks.

A single **DCM** card running the **SS7IPGW application** provides connections to multiple **IP** devices (**IP-SCPs**, class 4 switches, class 5 switches, VoIP gateways, media gateway controllers, or remote access servers.) Multiple **DCM** cards running the **SS7IPGW** application are required, with similar configuration, to provide redundancy. The following is a common sequence of events that illustrates the use of point-to-multipoint connectivity:

1. Traditional **SS7** devices route **MSUs** (such as **ISUP** Queries) to the gateway.
2. The gateway forwards the translated **MSU** to the correct **TCP/IP** device based on point code and filter information in the **MSU**.
3. The **ISUP** query is processed at the **IP-SEP**, and the **IP-SEP** sends an **ISUP** reply back to the gateway.
4. The gateway forwards the **ISUP** reply back to the sender of the original query.

To provide point-to-multipoint connections for **SEP** connectivity via **ISUP** over **IP**, a number of administration steps must first be performed, as follows:

- Set the **ISUP** over **IP** feature bit (`ipisup`). This is done with the `chg-feat` command.
- Links, link sets, destinations and routes to the destinations must be configured.
- The socket connections at each **DCM** card running the **SS7IPGW** application must be configured.
- The **SS7** routing keys that are transported over each defined socket at each card must be configured. **SS7** routing keys are filters consisting of values representing the **DPC**, **SI**, **OPC** and **CIC** fields from a incoming **MSU** message. All **MSUs** that match the filter are sent to the corresponding socket. The sockets represent **TCP** sessions. These keys allow for distribution of **MSUs** on the **IP** network.

3.165 ITU DTA (a.k.a. ITU Triggerless Message Screening) (Release 31.6)

Description

ITU Database Transport Access (DTA) is used to divert **SS7** traffic to an internal or external **SCP** process (via **SS7**, X.25 or **IP**) for application handling.

DTA intercepts **MSUs** that need further application processing and delivers the MSUs to the SCP for modification. The **SCP** sends the processed MSU to the **EAGLE** to be routed to its final destination.

The redirect function allows the EAGLE to trap MSUs, modify them, and process the new MSUs as ordinary messages. The redirect function essentially diverts an MSU from the original **DPC** to the DPC specified by the user.

The original implementation of DTA supported **ANSI** only. **ITU DTA** allows transmission to any **PC** type. However, the **EAGLE** currently allows only a single DTA DPC to be provisioned. If the incoming message type is not the same as the DTA DPC, the message will be “tunneled” to the DPC. The redirect function encapsulates the original MSU in the **SCCP** data part of a new MSU. The **CgPA SSN** is designated as the information element to identify the payload type. Payload types are identified in the following table. Tunneling allows multiple payload types to be carried in the SCCP data. The original DTA implementation for ANSI used SSN=0 for all MSUs; there is no change for ANSI payloads. If the EAGLE ANSI True PC is used, it may be converted to a **Secondary Point Code** during routing.

Table 3-22 Payload Type MSU encoding information

Payload Type	CgPA SSN	Redirected MSU OPC
ANSI	0	Original OPC
ITU-I/ITU-N	259	EAGLE ANSI True PC
ITU-N24	251	EAGLE ANSI True PC

Tunneling uses a **MTP2/MTP3/SCCP** header based on the DTA DPC point code type to allow any incoming message to be routed to the DTA DPC. For example, ITU tunneling involves placing an ANSI wrapper around an ITU message and sending it to an ANSI destination. The destination then removes the ANSI wrapper and processes the original ITU information. Tunneling works in the same way for an ANSI MSU encapsulated for an ITU destination.

The original implementation of DTA supported ANSI only. ITU DTA allows transmission to any PC type.

Limitations

- The redirect function must be performed on the receiving **LIM**.
- Only MTP screening can select MSUs to be redirected. the SCCP screening functions (**CGPA**, **TT**, **CDPA**, and **AFTPC**) cannot select MSUs to be redirected.
- MSUs may be too large to be encapsulated by the redirect function.
- **SLTA** (Signal **Link** Test Acknowledgement) messages should not be redirected. Do not apply a Redirect Stop Action on the Adjacent Node point code for any of the screening functions: **BLKOPC** or **OPC** .. When a Redirect Stop Action is applied to an **OPC** or

BLKOPC screen rule, inbound SLTAs from an adjacent node are not processed by the EAGLE.

- MSUs can be directed only to a single ANSI/ITU-I/ITU-N/ITU-N24 point code.
- Do not apply a Redirect Stop Action for an allowed DPC screen rule if the rule contains the point code of EAGLE where the screening rule is applied. This is because the redirection of **SLTA** / SLTM's (Signal Link test Messages) will not return to the originating EAGLE and will cause the link to fail.
- If the DTA DPC is the EAGLE, the local SCCP subsystem is active, and TVG is unable to obtain an SCCP grant for the redirected message, the message is discarded without UDTs generation. This could occur if SCCP is overloaded/ congested. Discard is the normal operation upon TVG grant failure.
- Do not apply a Redirect Stop Action after any **SIO** screening rule where **SI=1** or **SI=2**.

3.166 ITU Duplicate Point Code Routing (Release 26.05)

This feature allows an **EAGLE STP** mated pair to route traffic for two or more countries that may have overlapping point code values. For example, in the network shown in the following figure, both Country 1 and Country 2 have **SSPs** with a **PC** value of 2047.

Figure 3-13 Network Example #1

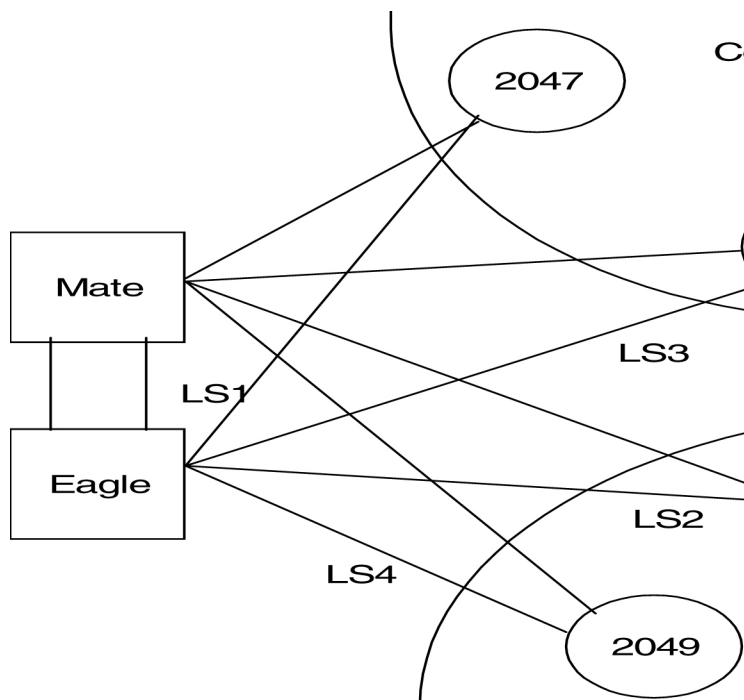

Users must divide their **ITU-National** destinations into groups. These groups will likely be based on Country. However, one group could have multiple countries within it, or a single country could be divided into multiple groups. The requirements for these groups are:

- No duplicate point codes are allowed within a group.
- **ITU-National** traffic from a group must be destined for a **PC** within the same group.
- The user must assign a unique two-letter group code to each group.

For example, in the network shown in the figure, Country 1 can only have 1 point code with a value of 2047. Traffic coming from **SSP** 2047 in Country 1 can only be destined to other nodes within Country 1. In this example, the user assigns a group code of 1 to Country 1, and a group code of 2 to Country 2.

When the user enters an **ITU-National** point code, he or she must also enter the group code, using the format "point code - group code". This group code must be used for any command that uses an **ITU-N** point code.

For current details on this feature, refer to the **Database Administration Manual - SS7**.

3.167 ITU Gateway Measurements Enhancements (PR19536) (Release 26.05)

Description

The **ITU GTWY** measurements schedule allows for the collection and reporting of **ITU** gateway-related data from the **STP**. The **EAGLE** already has **ANSI GTWY** measurements collection and reporting facility in place, but the **LIM** & **SCCP** cards do not currently measure the **ITU** data required to be reported in the **GTWY** measurements schedule.

To address this situation, the **LIM** & **SCCP** cards have been modified to measure this data, and the **OAM** has been modified to collect it from the **MTP (LIM)** and **SCCP** cards, store it, and report it when requested.

The **OAM** currently polls **MTP** and **SCCP** cards every 30 minutes for **GTWY** measurements data. The responses the **MTP/SCCP** cards send back in response to these polls has been extended to include the **ITU** gateway-related data required by the **ITU GTWY** measurements. The **OAM** now stores this data in the measurements database, and retains it for a 25-hour period (same as for **ANSI** measurements).

New Measurements Reports Implemented for this Feature

The following **ITU GTWY** measurements have been implemented for this feature.

- The **ITU GTWY** measurements for the **STP**, **LNKSET**, **LSDESTNI** and **LSORIGNI** entity types have been implemented. The implementation is based on the existing **ANSI GTWY** measurement processing, with the exception that the **ITU GTWY** measurements are done per Linkset basis, whereas **ANSI** measurements are done per Linkset per **NI** basis.
- The measurements for entity type **LNKSET** provide the counts for various types of **MSUs** (for example, **TFP/TCP**, **TFR/TCR**, **TFA/TCA**, **SLTA/SLTM**, sub-system messages, and so on) received and transmitted per **ITU GTWY** Linkset.
- The measurements for entity type **LSDESTNI** provide the counts for inter-network messages received and transmitted per **ITU GTWY** Linkset.
- The measurements for **LSORIGNI** provide the counts for the various types of **MSUs** rejected, as a result of **Gateway Screening** failure due to one or more factors. The measurements are done per linkset basis.
- The **STP-GTWY** measurements provide the aggregate of other **GTWY** types measurements on a system total basis.

The diagrams below illustrate various **GTWY** configurations (**OPC/ DPC** in networks other than **EAGLE's Adj Point Code**).

Figure 3-14 ANSI Gateway Configuration - (Linksets LSA1 & LSA2 are ANSI Gateway Linksets)

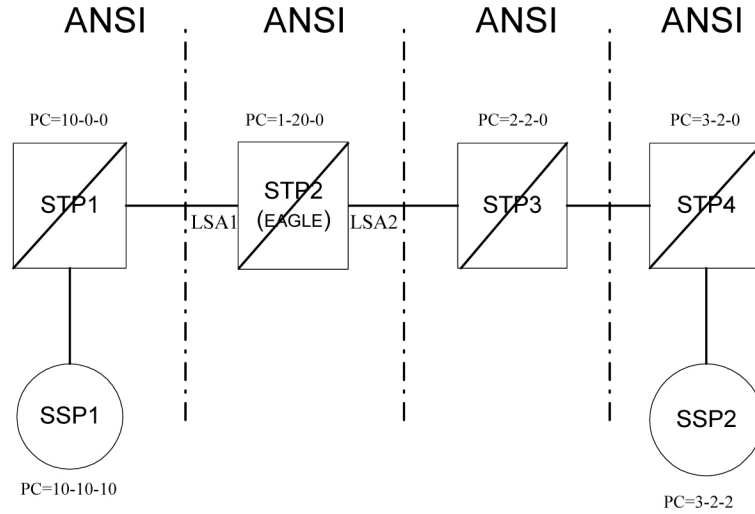

Figure 3-15 ITU Gateway Configuration (Linksets LSI1 & LSI2 are ITU Gateway Linksets)

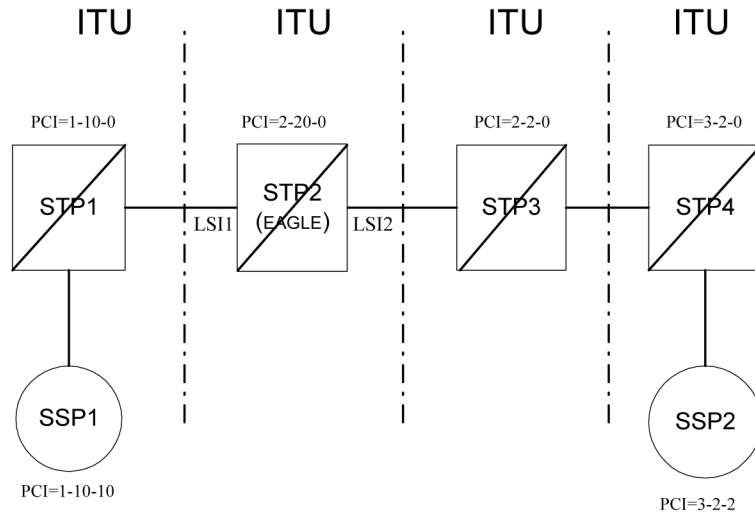
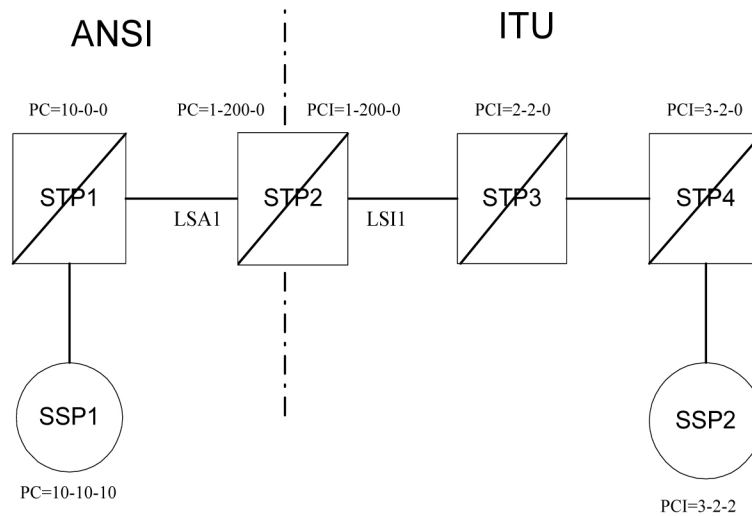

Figure 3-16 ANSI-ITU Gateway Configuration



To obtain these measurement reports via the **EAGLE** interface, the value "gtwy" must be specified for the `type` parameter for the `rept-meas` command. For the `rept-meas:type=gtwy` command, support for **STP**, **LNKSET**, **LSDESTNI** and **LSORIGNI** as valid values for the `type` parameter is continued.

3.168 ITU International and National Spare Point Code (Release 34.0)

Description

The EAGLE allows a network operator to use the same Point Codes across two networks (either ITU-I or ITU-N). The feature also enables both ITU spare and non-spare traffic to be routed over the same linkset. The EAGLE uses the MSU Network Indicator (NI) to differentiate the same point code of one network from the other. In accordance with the SS7 standard, unique Network Indicator values are defined for ITU-I, ITU-N, ITU-I Spare, and ITU-N Spare Point Code types.

The EAGLE currently provides full support for four types of point codes:

- ANSI, ITU-National (NI=10binary)
- ITU-National 24-bit
- ITU-International (NI=00 binary)
- ITU National Spare PCs (NI=11 binary) can be primarily supported via a combination of the following two items:
 1. Support for ITU-National Spare can be set on a per linkset basis using the linkset NIS parameter. If set, the EAGLE will allow receipt of messages with NI=11binary on the designated linkset and will force all outgoing messages on that linkset to have NI=11binary.
 2. The Duplicate Point Code routing feature, combined with the Multiple Point Code Support feature, can be used to create a separate routing group for a National Spare Point Code network.

While these two functions can be combined to support ITU National Spare Point Code routing, there are limitations described as follows:

- The EAGLE cannot distinguish between messages with different network indicators received over the same linkset. For example, the EAGLE will route a message with DPC = 1-1-1 (NI=10binary) the same way as a message with DPC = 1-1-1 (NI=11binary).
- Forcing the user to use the Duplicate PC Routing feature requires that all linksets in the system be placed in one of the defined groups.

The Spare Point Code Support feature addresses the above limitations and provides a new PC sub type named Spare that supports both the ITU-N Spare and ITU-I Spare Point Code feature.

Additionally, this feature requires a single linkset to support multiple outgoing network indicators (e.g. 11 binary, 00 binary). In turn, messages are routed according to the Point Code on the outgoing node that corresponds to the associated network indicator.

Hardware Requirements

There is no new hardware for this release.

Limitations

1. This feature does not allow the EAGLE to MTP convert between National and National Spare Point Codes. Likewise, this feature does not allow the EAGLE to MTP convert between International and International Spare Point Codes.
2. In the destination table, an ITU-I alias and an ITU-I Spare alias cannot be defined for the same Point Code, likewise an ITU-N alias and an ITU-N Spare alias cannot be defined for the same point code.
3. The feature is not supported on the SEAS interface. Spare point codes are only supported for ITU point codes, and SEAS only supports ANSI point codes. Any Private ANSI point code provisioned using the standard EAGLE 5 SAS command line interface is not displayed by the SEAS VFY- command.
4. ITU National and ITU National Spare Point Code are implemented as separate network domains that can co-exist within the same STP.
5. Spare point codes are not supported for IPGWI sockets using TALI protocols. The spare point code feature may not be enabled if any application sockets have been provisioned on IPGWI cards.
6. The existing implementation of Gateway Screening does not support Group Code (Duplicate Point Codes). Gateway Screening will also not support PPCs.
7. The Spare Point Code and PPC prefix value, s- and p- do not apply to domain type point codes for ANSI and ITU-N24.
8. ITU-N and ITU-N24 Point Codes cannot co-exist as SID Destination True Point Codes and therefore ITU-N Spare and ITU-N24 Point Codes cannot coexist as SID Destination True Point Codes.
9. A single STPOPTS value (cnvcgdi) will be used to control message handling for ITU-I and ITU-I Spare messages when the CgPA PC does not have a required alias.
10. A single STPOPTS value (cnvcgdn) will be used to control message handling for ITU-N and ITU-N Spare messages when the CgPA PC does not have a required alias.

11. The existing implementation of the SRVSEL command interface to the SRVSEL table does not provide a way to separate MSU traffic for different ITU National Group Code networks. Therefore no provision is made for the SRVSEL command to control the separation of ITU spare and non-spare traffic. The SRVSEL table applies to the EPAP based features G-FLEX, INP, G-PORT, SMS Prepaid, and IS-41 to GSM Migration. Likewise, no provision is made for the GTTSEL command interface to the GTTSEL table to allow separation of ITU spare and non-spare traffic for EGTT, VGTT and MGTT.

3.169 ITU MTP Restart (Release 26.0)

Description

ITU MTP restart is a network management feature. It enables a restarting signaling point to bring a sufficient number of signaling links into the available state, and to update its routing tables before user traffic is restarted to the newly available signaling point.

This feature enables operators to implement **ITU MTP** Restart throughout their networks.

A central part of the restart procedure is the exchange of network status information between the restarting **MTP** and the adjacent nodes. In order for the procedure to make sense, the network status should not change significantly during this information exchange. As a consequence, there is an overall restart time defined for the node whose **MTP** is restarting as well as for the adjacent nodes. During this time, all activities within the node whose **MTP** is restarting as well as the adjacent nodes should be completed. This requires that the time available is used in an efficient way.

As a basis of the restart procedure, it is assumed that most of the signaling points within the network are accessible. Thus at the beginning of the restart procedure, all concerned routes are considered to be allowed, and the update of the network status is performed by the exchange of transfer-prohibited (**TFP**) and/or transfer-restricted (**TFR**) messages. The **MTP** restart procedure uses the Traffic Restart Allowed (**TRA**) message that is defined in section 15 of Q.704.

When an adjacent node has finished sending all relevant **TFP** and/or **TFR** messages to the node with the restarting **MTP**, it finally sends a **TRA** message that indicates that all relevant routing information has been transferred. Thus, at the node with the restarting **MTP**, the number of received **TRA** messages is an indication of the completeness of the routing data.

When the restarting **MTP** has completed all actions or when the overall restart time is over, it sends **TRA** messages directly to all of its adjacent nodes accessible via a direct link set. These messages indicate that the restart procedure is terminated and User traffic should be started.

Refer to the *Database Administration Manual - SS7* for current information on this feature.

Upgrade Considerations

ITU MTP Restart introduces four new timers into the **EAGLE**'s Level 3 Timer Table (**IT18**, **IT19**, **IT20**, **IT21**). There now resides 24 extra bytes of padding in the Level 3 Timer structure. With each timer taking 4 bytes, the total number of bytes needed for the new timers is 16 bytes.

The Level 3 Timer provides plenty of space to house the four new timers. Therefore during upgrade, only a conversion function will be required to handle the new table. This will convert the old structures without the timers to the new structures with the new timers, and set the new timers to their default values.

Measurements

The measurement **MTPRESTS** will be pegged when **EAGLE** restarts. This is an existing peg count that was previously used by **ANSI** restart, and will now be used for **ANSI Only Restarts**, **ITU Only Restarts**, and **Mixed ITU/ANSI Restarts**.

Limitations

1. The **EAGLE** will delay bringing into service Linksets that are not Restart Capable (`mtprse=no`) until after Restart is Complete.
2. While it is desirable to bring one link per linkset into service first when performing a Full Restart, because of the **EAGLE**'s distributed architecture there is no advantage to this. Thus the **EAGLE** tries to align all links.
3. The restarting node should stop T18 when sufficient links are available, and enough **TRA** messages have been received. The **EAGLE** will stop T18 when all activated restart capable links are available, and it has received **TRAS** on all restart-capable linksets.
4. If all **ITU** links fail, but the **EAGLE** still has **ANSI** links available, the **EAGLE** will not perform a Full **MTP** Restart. In a Mixed **ANSI/ITU** network, the **EAGLE** will only perform a Full restart if all links, both **ITU** and **ANSI**, fail.
5. **TFPs** received on a link before the link is available at Level 3 will not be processed.

3.170 ITU SLS Enhancements (Release 26.0)

Description

The **ITU SLS** Enhancements feature gives **EAGLE** customers the ability to modify the method the **EAGLE** distributes traffic across **ITU SS7** links.

EAGLE uses the **LSB** of **SLS** to load share between linksets of a combined linkset. **ITU-T ISUP** messages use a **SLS** that is obtained from the lower 4 bits of the **CIC** field representing the circuit being used.

CIC selection can be determined based on an odd/even method where a **SSP** uses either all odd **CICs**, or all even **CICs**, to help prevent “glaring” (i.e., 2 **SSP** attempting to seize the same trunk at the same time). This causes the **LSB** of the **SLS** to be fixed; if the **LSB** is fixed, inadequate load sharing occurs for the **SS7** network. This situation can also occur within a single linkset (international), since **EAGLE** also uses the **SLS** (containing a fixed **LSB**) to select a link within a linkset.

Refer to the *Database Administration Manual - SS7* for current information on this feature.

Restrictions

When two linksets are used as a combined linkset, they should have the same *Other CIC Bit* and *Rotated SLS Bit* settings. This is not enforced in the **EAGLE**, and there is no warning mechanism for incorrectly provisioned linksets and routes

Upgrade Considerations

- Default values “Bit Rotation” and “Other Bit” must be set in **LS** tables during upgrade from Release 25 to 26.

- The *Use Other CIC Bit* feature bit must be set to disabled during the upgrade.

3.171 ITU TCAP LRN Query (Release 40.0)

The ITU TCAP LRN Query (**LRNQT**) feature provides LNP support to an ITU TCAP LRN query and response, using the local routing number (LRN) method to support number portability. The translation type (**TT**) value for this query is configurable on the EAGLE 5 ISS.

3.171.1 Feature Control Requirements

The LRNQT feature has the following feature control requirements:

- FAK for part number 893-0263-01
- An LNP quantity feature that is greater than or equal to 24 Million must be turned on before the LRNQT feature can be enabled.
- A temporary FAK cannot be used to enable the feature.
- The feature cannot be turned off after it has been turned on.
- The feature must be turned on before any provisioning can occur.

3.171.2 Hardware Requirements

The LRNQT feature operates on all hardware that supports existing LNP applications.

3.172 ITUN-ANSI SMS Conversion (Release 37.0)

Description

The ITUN-ANSI SMS Conversion feature performs SMS address conversion for Registration Notification, SMS Request Return Result, and SMS Notification messages crossing the ITUN-ANSI network boundary to determine the destination point code in the destination network.

A FAK is required to enable the ITUN-ANSI SMS Conversion feature.

The ITUN-ANSI SMS Conversion feature modifies the SMS Address parameter in the TCAP/IS41 layer of the Registration Notification, SMS Request Return Result, and SMS Notification messages that cross the ITUN-ANSI network boundary. These messages are called identified messages and are modified per the destination network type. The SMS Address parameter in the identified messages must contain an ANSI or ITU-N point code value to enable the ITUN-ANSI SMS Conversion feature to process the messages.

Feature Control Requirements

The ITUN-ANSI SMS Conversion feature has the following feature control requirements:

- A FAK for part number 893-0153-01
- A temporary key cannot be used to enable the feature.
- After the feature has been turned on, it cannot be turned off.

Hardware Requirements

The ITUN-ANSI SMS Conversion feature requires DSM or TSM cards running the SCCP application

Limitations

The ITUN-ANSI SMS Conversion feature has the following limitations:

- ITU-I and ITUN-24 point codes are not supported.
- If DSM and TSM cards are down, the ITUN-ANSI SMS Conversion is not performed.

3.173 ITU-TFR Procedure (Release 26.1)

Currently, the **EAGLE** implements most, but not all, of the signaling route management capabilities defined in **ITU-T** recommendation Q.704, section 13. In particular, those capabilities defined as national options are not yet implemented.

The ITU **TFR** (International Telecommunication Union - Transfer Restricted) feature implements the transfer-restricted procedures defined in section 13.4 of Q.704. The TFR procedure is used to redirect traffic away from a **STP** that is having problems routing traffic to a destination. When a STP determines that a destination is restricted, the STP will send, to its adjacent **SPs**, a TFR message containing an affected destination.

When a destination is restricted, the STP should not be used to route messages to the destination, even though it still has limited capability to do so. The TFR message is sent to the adjacent STPs to inform them of this condition.

The ITU TFR procedure can be enabled or disabled on a per ITU-N linkset basis (see [ITU Gateway Measurements Enhancements \(PR19536\) \(Release 26.05\)](#)). When the TFR procedure is enabled on a given linkset, TFR messages can be sent to the adjacent **PC** for the affected destinations.

Note:

The procedure does not apply to ITU-I linksets. The **ANSI** network employs its own similar version of the TFR procedure for ANSI linksets.

Upgrade Considerations

Default values for "ITU TFR Procedure" must be set in **LS** tables during upgrade to Release 26.1. [Table 3-9](#) shows the tables requiring modifications during the upgrade process.

¹ **ITU-T Recommendation Q.704, SS7 - Signalling network functions and messages**, ITU-T, July 1996.

Table 3-23 Tables and Fields Affected by Upgrade

Modified Tables	New Fields	Size	Value
Linkset	ITUTFR	1 byte	0 (off)

New UIMs

This feature introduces a new **UIM** that is output in the event a TFR message is received on a ITU-N linkset that does not support the ITU TFR Procedure (parameter is **OFF**).

```
1233 MTP Invalid ITU TFR RCVD
```

When this occurs, the craftsperson should check if the `itutfr` parameter needs to be enabled for the linkset, or if the problem exists on an adjacent STP.

3.174 ITU/ANSI Conversion SLS Enhancement (Release 45.0)

The ITU/ANSI Conversion SLS Enhancement feature enhances the SLS Conversion algorithm to allow 4-bit ITU SLS to 8-bit ANSI SLS and 5-bit ANSI to 8-bit ITU SLS conversion. These conversions are supported for GT-routed messages.

3.175 J7 Feature (Release 45.1)

J7 Support Over SIGTRAN

The Eagle requires updates to be made in order to support the Japanese TTC (Telecommunication Technology Committee) standards, also known as J7. SIGTRAN specific implementation (SS7 networks) in Japan do not use standard ITU formats and procedures. The TTC has modified the ITU specifications to suit Japanese telecom signaling requirements.

Configurable J7 Point Code Format

- When the J7 feature is enabled, a new parameter is available in the STPOPTS table: PCN16FMT. This parameter has two values:
 - 745 (UN-SNA-MNA format) (default)
 - 547 (MNA-SNA-UN format)

Eagle displays command input, output, and UAM/UIMs for the ITUN16 point codes in the format specified by PCN16FMT when the J7 feature is enabled.

Extended J7 Requirements

- Feature is supported over M3UA/M2PA links only - the linkset configured for ITUN16 APC cannot have DS0, E1/T1 or ATM links.
- Eagle sets "Network Indicator" field to 0 for MSUs destined toward ITUN16 point code (`dpc=itun16`).
- ITUN16 linksets' default `sltset` uses a test pattern of 1177 as per JT-Q707.

- Feature adds new point code type ITUN16 to support the 16 bit point code and MTP3 routing label formats used in Japanese networks.
- Feature adds support for JT-Q704/JT-Q707 procedures and messaging.
- Feature adds a new default Signalling Link Test set (sltset 3) for ITUN16 linksets for TTC SRT/SRA messaging.
- ITUN16 point code type is mutually exclusive with ANSI and ITUN24 point code types; thus, the Eagle node can support ITUN16 or ANSI/ITUN24 types but not both at the same time.

3.175.1 Feature Control Requirements

- FAK for Part Number 893-0408-01.
- A temporary FAK cannot be used to enable the feature.
- The feature cannot be enabled if ANSI and/or ITUN24 point codes are provisioned.
- The feature cannot be turned off after it has been turned on.

3.176 J7/TTC for J1-LSL Low Speed Link Support (Release 46.0)

The J7/TTC for J1-LSL Low Speed Link Support feature provides Japanese TTC MTP1/MTP2 variant support for Low Speed Links E1/T1 56kb/s and 64kb/s.

3.177 KSR Terminal Feature (Release 20.0)

The Keyboard Send Receive (**KSR**) feature enhances the **EAGLE**'s dial-up administration functions by allowing faster throughput, since the control characters associated with the **VT320** mode of terminal operation need not be transmitted.

The command used to modify the terminal configurations has a new parameter added to enable the **KSR** feature.

4

Features L - O

This chapter describes features starting with letters from L to O.

4.1 Large BICC MSU Support for IP Signaling (Release 37.0)

Description

The Large BICC MSU Support for IP Signaling enhances the EAGLE 5 ISS by increasing the SIF size of the BICC MSUs that the system can send and receive from 272 bytes to 4095 bytes over the M2PA and M3UA protocols.

A FAK is required to enable the Large BICC MSU Support for IP Signaling feature.

The Large BICC MSU Support for IP Signaling feature increases the SIF size of the Bearer Independent Call Control (BICC) MSUs that the EAGLE 5 ISS can send and receive over the M2PA and M3UA protocols from 272 bytes to 4095 bytes.

The Large BICC MSU Support for IP Signaling feature allows large BICC MSU traffic on IP7 signaling-links/connections cards. The cards that support the feature include the SSEDCCM cards (SS7IPGW, IPGWI, IPLIM, and IPLIMI GPLs) and the E5-ENET cards (IPGHC and IPLHC GPLs).

The feature also prevents routing of large BICC MSU traffic on non-IP7 GPLs. The IPGWx software rejects a large BICC MSU if it arrives on a double-slot DCM card. If a large BICC MSU is rejected, then the MSU is discarded, a discard measurement is updated, and a UIM is issued.

The feature supports ANSI, ITU-N, ITU-I and ITU-N24 networks.

If the feature is enabled and turned on, then BICC MSUs with a SIF size greater 272 bytes can be routed. MSUs with a SIF size that is equal to or less than 272 bytes can be routed when the feature is not enabled.

Note:

Data feed to the Sentinel and IMF systems is not supported for BICC MSU messages with a SIF size greater than 272 bytes. DTA and STP LAN do not support large BICC MSUs. If a large BICC MSU initiates DTA or STPLAN processing, then the MSU is routed without copying and the appropriate UIM will be issued. See Table FN-3 on page FN-94 for more information for the UIMs generated for the Large BICC MSU Support for IP Signaling feature.

Measurements

The following LINK-COMP measurements are added for the Large BICC MSU Support for IP Signaling feature:

- LMSURCV: Number of large MSUs received

- LMSUTRN: Number of large MSUs transmitted
- LMSUOCTRCV: Number of octets received in large MSUs
- LMSUOCTTRN: Number of octets transmitted in large MSUs
- LMSURCVDSC: Number of large MSUs discarded in the receive path
- LMSUTRNDSC: Number of large MSUs discarded in the transmit path

Feature Control Requirements

The Large BICC MSU Support for IP Signaling feature has the following feature control requirements:

- A FAK for part number 893-0184-01
- A temporary key cannot be used to enable the feature.
- The feature can be turned off after it is turned on.

Hardware Requirements

None.

Limitations

None.

4.2 Large MSU Support for IP Signaling (Release 42.0)

The Large MSU Support for IP Signaling feature allows the Large BICC MSU Support for IP Signaling feature to support additional service indicator (SI) values. As part of this feature, the Large BICC MSU Support for IP Signaling feature is now referred to as the Large MSU Support for IP Signaling feature.

The Large MSU Support for IP Signaling feature supports MSUs with a **SIF** size of up to 4095 bytes for M2PA and M3UA protocols with SI values from 6 - 15.

The SI values are:

- 6, 7—Data
- 9—Broadband ISDN
- 10—Satellite ISDN
- 13—BICC
- 14—H.248
- 8, 11, 12, 15—Spare

The SLAN, Database Transport Access (DTA), and **E5IS** features do not support Large MSUs.

4.2.1 Feature Control Requirements

- The Large MSU Support for IP Signaling feature continues to be enabled by a FAK for part number 893-0184-01. The existing FAK is expanded to support large MSUs with SI from 6 - 15.
- The feature can be turned on and off.

- If the feature is turned on, then MSUs with a SIF size from 272-4095 bytes can be routed.
- If the feature is turned off, then MSUs with a SIF size greater than 272 bytes are not routed.

4.2.2 Hardware Requirements

Large MSUs are supported by SSEDCEM and E5-ENET cards and by SS7IPGW, IPGWI, IPLIM, IPLIMI, IPGHC, IPLHC and IPSG GPLs.

4.3 Large System (Release 27.2)

Description

EAGLE 27.2 introduces the Large System Feature, which increases the number of **SS7** high- and low-speed links supported by the EAGLE, currently limited to 500 links per system, to 700 links.

The **EAGLE** Large System supports, with the existing 250 available card slots, the simultaneous operation of the following combinations of links:

Table 4-1 Large System Configurations

Configuration	ATM Links	Low Speed Links
Configuration #1	100	600
Configuration #2	0	700

- Low speed links are defined as 56kb/sec or 64kb/sec links achieved through multi-port LIMs or any combination of the multi-port LIMs and 2-port LIMs.
- **ATM** links are defined by the existing EAGLE High Speed Link feature provided via the LIM-ATM board. Up to 100 of the 700 links can be LIMATM links.

4.4 Large System—Phase 2 (Release 28.0)

Description

This feature builds upon the Large System foundation, and increases the number of **SS7** high- and low-speed links supported by the **EAGLE** to 1200 links.

Refer to the **Database Administration Manual - SS7** for more information.

Hardware Required

To provision up to 1200 signaling links in the database, the following hardware must be installed:

- **HMUX** cards, P/N 870-1965-XX, replacing all the **IPMX** cards.
- **GPSM-II**, P/N 870-2360-XX or later, installed in card locations 1113 and 1115.

▲ Caution:

Never install or initialize **MCAP** cards in **MASP** slots 1113 and 1115 after features that require **GPSM-II** cards are provisioned.

Attempting to initialize **MCAP** cards with **GPSM-II** features provisioned will cause a system outage. Before replacing an existing **GPSM-II** card in a **MASP** slot (1113 and 1115) contact Tekelec Customer Service.

- **TDM**, P/N 870-0774-10 or later, installed in card locations 1114 and 1116.
- **Control Shelf** Backplane, P/N 850-0330-06
- The Measurements Platform feature must be enabled.
- Enough Multiport **LIMs (MPL)**, P/N 870-1826-XX, or **E1/T1 MIMs**, P/N 870-2198-XX to bring the number of signaling links from 701 to 1200, installed according to the provisioning rules for a 1200 signaling link system; see the following section. The system can contain a mix of 2-port **LIMs**, Multiport **LIMs**, and **E1/T1 MIMs**.

For detailed hardware information, refer to the *NSD Hardware Manual*.

4.5 Large System (Phase 3)—1500 Links (Release 29.0)

Description

The Large System (Phase 3)—1500 Links feature is the **EAGLE** with 1,500 links.

Customers continue to rapidly expand their link capacities beyond the configuration supported in previous releases. The Large System—Phase 2 feature with 1200 links, 115 **ATM** cards and 100 **IPLIMs**, implemented in Release 28.0, has been expanded to include additional links, as well as Sigtran-based associations.

With the increased number of links (and with the introduction of the 6,000 Routesets feature) the Multicast traffic will grow significantly.

With this feature, the total number of signal links supported by **EAGLE** is 1500 total links per system. The **EAGLE** also enforces the following link/card counts:

- Maximum of 1500 links is the total number of links supported per system:
 - Default of 1200 links are allowed
 - Allow maximum 1500 links by Feature **Key**
- Within the total number of links allowed, the user may provision:
 - Maximum 115 **ATM** cards
 - Maximum 100 **IPLIM** cards
 - Maximum 2 **SS7IPGW (ANSI)** application **DCM** cards
 - Maximum 2 **IPGWI (ITU)** application **DCM** cards

The **EAGLE** enforces a maximum link count of 1500 total links per system, as well as the following link/card counts:

- Maximum 1500 links
- Maximum 115 **ATM** cards

- Maximum 100 **IPLIM** cards
- Maximum 2 **IPGTWY** cards

For this feature, the **EAGLE** provides feature access keys to exceed 1200 links. The default for these feature access key is **OFF**.

Hardware Requirements

No new hardware required or introduced to support the software. However, in order to provision more than 1,200 links, the **EAGLE** must be equipped with the **HMUX** and **TDMs** (870-0774-10) or later, and **GPSM-II** must be the active and standby **EOAM**.

Caution:

Never install or initialize **MCAP** cards in **MASP** slots 1113 and 1115 after features that require **GPSM-II** cards are provisioned. Attempting to initialize **MCAP** cards with **GPSM-II** features provisioned will cause a system outage. Before replacing an existing **GPSM-II** card in a **MASP** slot (1113 and 1115) contact Tekelec Customer Service.

4.6 Last 10 Command Retrieval (EAGLE Release 30.0/IP7 Secure Gateway Release 8.0)

Description

Currently the **EAGLE** supports retrieving the last command entered from the terminal only. Customers use this feature when making multiple entries that require only minor changes to the previous command. They want the ability to display the last 10 commands entered, in a manner similar to the **DOSKEY** function.

The Last 10 Command Retrieval feature supports command retrieval of at least the last 10 commands entered at **KSR**, **VT 320**, and **SCCS** type terminal (up to 20 commands for **IP** User Interface terminals). This capability is supported at the **EAGLE MMI** terminals, as well as at terminals connected via the **IP** user interface.

Note:

This feature is supported only on **KSR**, **VT 320**, and **SCCS** type terminals. Terminals configured as **SEAS** or **OAP** terminals are not supported for this feature.

Hardware Requirements

No new hardware is needed to support this feature.

Limitations

Resetting the **COM** parameters on terminal clears the history queue. This is only done internally by software. This occurs when a terminal is inhibited and allowed (i.e. `inh-`

`trm:trm=xx` and `alw-trm:trm=xx`) or Kermit transfer is initialized (i.e. with command `act-file-trns`).

4.7 Link Failure Status Information (Release 22.0)

The level 2 **SS7** data is divided into 2 groups, service data and alignment data.

Service data is a running history of when the link comes in service and goes out of service. The history contains the reason the link fails from the perspective of Level 2 along with the timestamp. This information can be used to help solve whether the near end or far end node is responsible for causing the link to fail. This is a list of all the possible level 2 link failure reasons.

- **RC/BSNR** link failure — Received two out of three invalid backward sequence numbers from the far end. The far end office should be contacted to determine why invalid **BSNs** are being sent.
- **RC/FIBR** link failure — Received two out of three invalid forward indicator bits from the far end. The far end office should be contacted to determine why invalid **FIBs** are being sent.
- **SIE** received — Received status indication of Emergency from the far end. An **SIE** indicates the far end is now being aligned. The far end office should be contacted to determine why an **SIE** was sent.
- **SIN** received — Received status indication of Normal from the far end. An **SIN** indicates the far end is now being aligned. The far end office should be contacted to determine why an **SIN** was sent.
- **SIO** received — Received status indication of Out of Alignment from the far end. An **SIO** is sent when the node begins initial alignment. The far end office should be contacted to determine why an **SIO** was sent.
- **SIOS** received — Received status indication of Out of Service from the far end. An **SIOS** is sent upon completion power up until initial alignment is started. An **SIOS** is also sent when the far end cannot transmit or receive message signal units for reasons other than processor outage. The far end office should be contacted to determine why an **SIOS** was sent.
- Stop commanded — Level 3 commanded Level 2 to stop.
- Stopped receiving data — No data is being received on the signaling link. Check the physical connections of the signaling link. Using an analyzer, test for level 1 and level 2 functions.
- **SUERM** link failure — Signal Unit Error Rate Monitor (**SUERM**) counter exceeded threshold. The **SUERM** maintains a counter to estimate the signal unit error rate. The far end office should be contacted to determine why the error rate is high.
- Too many **ISCC** interrupts — Too many interrupts received over the link.
- **TXC/T6** expired — Remote congestion timer expired. The far end is in congestion too long. The far end office should be contacted to determine why **BSN** and **BIB** are not being sent.
- **TXC/T7** expired — Excessive delay of acknowledgment timer expired. Far end taking too long to acknowledge the messages sent to it by the near end. The far end office should be contacted to determine why the delay in acknowledging **MSUs**.

The level 2 link failure reason shows which node on the link caused the fault and why. If the history shows the link did not realign after the failure, the alignment data buffer shows the reason the link was unable to be realigned.

Alignment data is a running history of Level 2 alignment events with timestamps. This information can be used to help solve why the link does not realign.

Alignment events are buffered during the out of service, initial alignment, aligned/ready and aligned/not ready states. Only the first unique occurrence of an event and its timestamp is buffered. Alignment events are transmitted signal units, received signal units, level 3 commands, level 2 status and state transitions. The following table lists all the possible alignment events sorted by event type. Realignment may fail for reasons other than the events listed in the table. For example, realignment fails if an **SIO** is received when the link is in the aligned/ready state. Therefore, the failure reason is displayed as an abnormal link state control state transition.

Table 4-2 Signaling Link Alignment Events

Transmitted	Received	State	Event
FISU	FISU/MSU	IAC Idle	AERM /Abort proving
SIO	SIO	IAC Not aligned	T2 expired
SIE	SIE	IAC Aligned	T3 expired
SIN	SIN	IAC Proving	Exceeded proving period count
SIB	SIB	Out of Service	Stop commanded
SIOS	SIOS	Initial Align	SUERM link failure
SIPO	SIPO	Align/Ready	RC/BSNR link failure
		Align/Not Ready	RC/FIBR link failure
		In Service	Stopped receiving data
		Processor Outage	Too many ISCC interrupts
			T1 expired

These are definitions of the alignment failure reasons.

- **AERM**/Abort proving - Alignment Error Rate Monitor (**AERM**) counter exceeded threshold. **AERM** increments a counter if it detects an error in the signal unit. Aborting the proving period causes the proving period count to be incremented. If the proving period count exceeds its threshold, the link will fail with the Level 2 Exceeded proving period count failure reason. The far end office should be contacted to determine the cause for the high error rate.
- Exceeded proving period count - The proving period was aborted five times by the **AERM** before the proving period timer expired. The far end office should be contacted to determine the cause for the high error rate.
- **RC/BSNR** link failure — Received two out of three invalid backward sequence numbers from the far end. The far end office should be contacted to determine why invalid **BSNs** are being sent.
- **RC/FIBR** link failure — Received two out of three invalid forward indicator bits from the far end. The far end office should be contacted to determine why invalid **FIBs** are being sent.
- Stop commanded — Level 3 commanded Level 2 to stop.

- Stopped receiving data — No data is being received on the signaling link. Check the physical connections of the signaling link. Using an analyzer, test for level 1 and level 2 functions.
- **SUERM** link failure — Signal Unit Error Rate Monitor (**SUERM**) counter exceeded threshold. The **SUERM** maintains a counter to estimate the signal unit error rate. The far end office should be contacted to determine why the error rate is high.
- **T1** expired - Align/Ready timer expired. Far end is not responding during Aligned/Ready or Aligned/Not Ready states before timer expires. The far end office should be contacted to determine why the far is not responding.
- **T2** expired - Not aligned timer expired. Far end is not responding during Not Aligned Initial Alignment Control state before timer expires. The far end office should be contacted to determine why the far end is not responding.
- **T3** expired - Aligned timer expired. Far end is not responding during Aligned Initial Alignment Control state before timer expires. The far end office should be contacted to determine why the far end is not responding.
- Too many **ISCC** interrupts — Too many interrupts received over the link.

The service data and alignment data is displayed with the `L2stats` parameter of the `rept-stat-slk` command. The `L2stats` parameter has the following values:

`no` = don't display Level 2 status information (the default value)

`align` = display alignment data only

`service` = display service data only

`both` = display both alignment and service data

`brief` = display at most last 10 alignment data events only

The alignment data is displayed in a three column format. Column 1 is the type of event that was buffered. Column 2 is the event. Column 3 is the timestamp for the event.

The service data is displayed in a two column format. Column 1 contains the event. Column 2 has the corresponding timestamp.

The following is an example of how the service data and alignment data is displayed.

Input/Output Examples

```
rept-stat-slk:loc=1203:port=b:L2stats=both
```

```
SLK   LSN       CLLI           PST           SST           AST
1203,B lsnssp2  ----- OOS-MT-DSBLD LPBK          ISCC
```

```
Event Type Event                Timestamp
Transmit  SIOS                    97-06-07 10:04:23.000
State     Out of Service          97-06-07 10:04:23.000
State     Initial Align          97-06-07 10:05:31.100
State     Idle                    97-06-07 10:05:31.100
Transmit  SIO                     97-06-07 10:05:31.105
State     Not Aligned             97-06-07 10:05:31.105
Receive   SIO                     97-06-07 10:05:46.425
Transmit  SIN                     97-06-07 10:05:46.430
```

```

State      Aligned          97-06-07 10:05:46.430
Receive    SIN              97-06-07 10:06:02.110
State      Proving          97-06-07 10:06:02.120
Receive    SIN              97-06-07 10:06:02.885
State      Idle             97-06-07 10:06:53.625
Transmit   FISU             97-06-07 10:07:14.000
State      Align/Ready     97-06-07 10:07:14.000
Receive    FISU             97-06-07 10:08:01.760
State      In Service      97-06-07 10:08:01.760

```

```

Service Event      Timestamp
In Service         97-06-07 02:11:54.875
SIOS received     97-06-07 05:40:10.160
In Service         97-06-07 05:42:12.235
SIOS received     97-06-07 09:37:02.100
In Service         97-06-07 09:38:55.995
SUERM link failure 97-06-07 10:02:02.125
In Service         97-06-07 10:08:01.760

```

rept-stat-slk:loc=1203:port=b:L2stats=brief

```

SLK   LSN      CLLI          PST          SST          AST
1203,B lsnssp2 ----- OOS-MT-DSBLD LPBK         ISCC

```

```

Event Type Event      Timestamp
Transmit   SIOS          97-06-07 02:44:23.000
State      Out of Service 97-06-07 02:44:23.000
State      Initial Align  97-06-07 02:45:31.100
State      Idle           97-06-07 02:45:31.100
Transmit   SIO           97-06-07 02:45:31.105
State      Not Aligned    97-06-07 02:45:31.105
State      T2 Expired     97-06-07 02:45:46.425

```

If a card is unplugged, the link status information is lost.

The alignment data buffer and service data buffers are circular buffers that can hold 69 events.

The level 2 statistics can only be displayed for **SS7 LIMs**. If the specified signaling link is not an **SS7 LIM**, the command is rejected and this message is displayed.

Error Message

E2918 Cmd Rej: Link must be SS7 to display Level 2 stats

4.8 Link Fault Sectionalization (Release 21.0)

Overview

The **EAGLESTP** supports up to 16 **Link Fault Sectionalization (LFS)** tests at one time and a maximum of 32 remote link elements for each **LFS** Test while being able to display real time results of the tests in progress.

Link fault sectionalization allows maintenance personnel, using industry standard error patterns, to perform **DSOA** fault sectionalization tests, a series of far-end loopback tests from the local **EAGLESTP** or to a remote **EAGLESTP**, and to identify faulty segments of an **SS7** transmission path up to and including the remote network element. Refer to the following two figures.

The **SS7LIM** must be powered up and provisioned with the signaling link deactivated before starting the link fault sectionalization tests. No messages are transferred to or from the signaling link by the **SS7LIM** while the link is performing a link fault sectionalization test.

Figure 4-1 DS0 Link LBPs for Latching Test

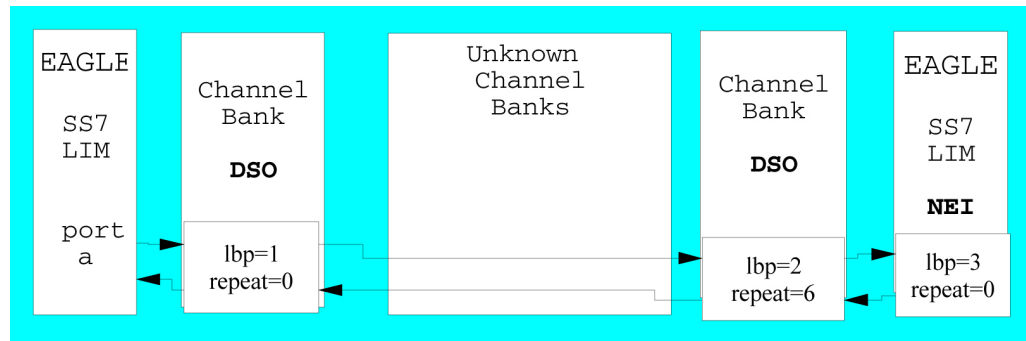
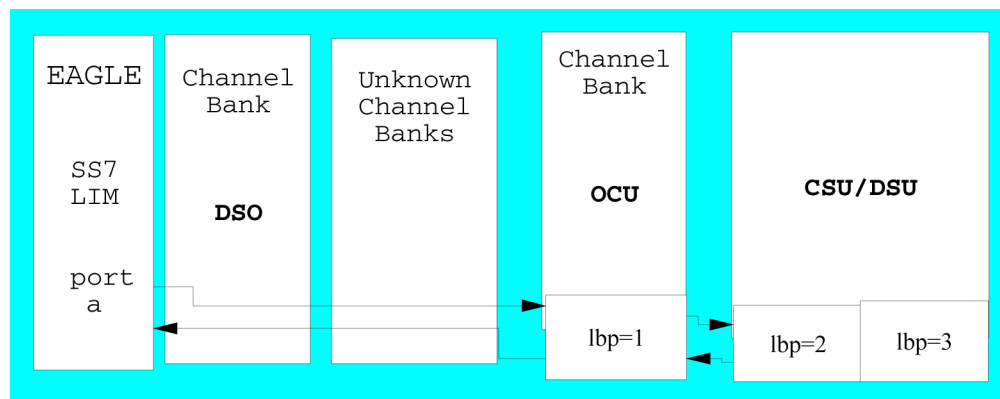

Figure 4-2 OCU/DCU Link LBPs for Non-Latching Test



The point on the signaling link at which each loopback test ends is called the far-end loopback point. A far-end loopback point (**LBP**) is achieved when the remote link

element (**RLE**) sends the received data back to the transmitter, allowing the transmitter to verify the received data.

The remote link elements are shown in the following table.

Table 4-3 Link Fault Sectionalization Tests Remote Link Element (RLE) Types

Element	RLE Description	Latching	Nonlatching
DSO	DSO Dataport	Yes	No
OCU	OCU Dataport	Yes*	Yes
CSU	CSU Dataport	Yes*	Yes
DSU	DSU Dataport	Yes*	Yes
NEI	Network Element Interface	Yes	No

* The **OCU**, **CSU** and **DSU** must be strapped or optioned to support latching link fault sectionalization loopback.

The **LBP** is moved along the signaling link path until the **LBP** is in the far-end network element. Therefore, each **LBP** along the link requires the initiation of one link fault sectionalization test on the **SS7LIM**.

The link fault sectionalization test types for loopback tests are shown in the following table.

Table 4-4 Link Fault Sectionalization Test Types

Link Fault Sectionalization Test Types	Description
Latching link fault sectionalization test (LLT -auto)	A loopback point is established using signaling commands and remains until it is removed by signaling commands.
Latching link fault sectionalization test (LLT -man)	A loopback point is established by manual means and remains until it is removed by manual means.
Nonlatching link fault sectionalization test (NLT)	A loopback command is interleaved with the test data.

Remote Loopback Testing for DS0A

This capability allows a **LIM** card at a remote location running the *ss7ansi* application to be placed in loopback automatically when it receives a valid latching loopback code sequence from the network (when a test pattern is detected). This allows the signaling link connected to that card to be tested from another far-end network element or maintenance test unit. While in loopback mode, the signaling link assigned to the **LIM** card that is in loopback mode is out of service.

Remote Loopback Testing for OCU

This feature allows a **LIM** card (configured as a **LIMOCU**) running the *ss7ansi* application to be placed in loopback automatically when it receives a valid latching loopback code sequence from the network (when a test pattern is detected). Both latching and nonlatching loopback are supported. Because latching and nonlatching loopback cannot be mixed in a network, the loopback testing mode selected depends on the network configuration and configuration of **OCU** channel bank. The **OCU** channel back recognizes the loopback control codes and does a current reversal. The **LIMOCU** only sees a current reversal and acts on

that without knowing whether it is latching or nonlatching. While in loopback mode, the signaling link assigned to the **LIM** card that is in loopback mode is out of service.

Link Diagnostics

Link Diagnostics provides detailed status information of link failures. This capability either confirms or eliminates a portion of the near-end node as the reason for the link failure.

Figure 4-3 Link Diagnostic Diagram

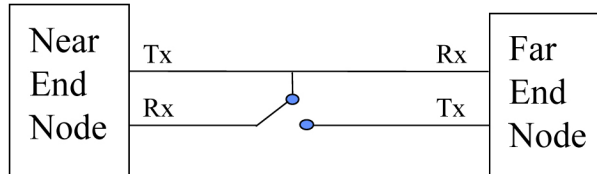

SS7 Level 2 status information is buffered before and after a link failure has occurred. This feature provides the capability to loop the internal transmit and receive data on the **LIM** card. **Link** failures can occur on the near end node, far end node, or the cable connecting the two nodes.

Link Failure Status Information

The Level 2 **SS7** data is divided into two groups: service data and alignment data.

Service data is a running history of when the link comes in service and goes out of service. The history contains the reason the link fails from the perspective of Level 2 along with the timestamp. This information can be used to help solve whether the near end or far end node is responsible for causing the link to fail.

Alignment data is a running history of Level 2 alignment events with timestamps. This information can be used to help determine why the link does not realign.

The service and alignment data buffer and service data buffers can each hold 69 events.

Hardware Configuration

The link fault sectionalization feature requires a **LIM** running the **SS7ANSI** application with the **AINF** interface. With this interface, the test data is guaranteed to be a continuous data stream, and the commands provide the ability to put any element in the link into latched loopback.

The test data is provided by the **AINF** interface and is shown in the following table. The data stream sent is verified against the data stream received and a bit error count is updated. When the bit error count exceeds 255, the value of the bit error count remains at 255 and does not overflow.

Table 4-5 Link Fault Sectionalization Test Patterns

Test Pattern	Data	Description
B2047	N/A	2047-bit Bert pattern sent until it is terminated by software.

Table 4-5 (Cont.) Link Fault Sectionalization Test Patterns

Test Pattern	Data	Description
B2047 Non Latching	N/A	2047-bit Bert pattern sent interleaved with loopback command until it is terminated by software.
B511	N/A	511-bit Bert pattern sent until it is terminated by software.
B511 Non Latching	N/A	511-bit Bert pattern sent interleaved with loopback command until it is terminated by software.
OCTET	default =h'32	A continuous series of the specified octet data is sent until it is terminated by software. (Latching only)
ALTERNATE	default = h'FF	A count of 100 octets of the specified data followed by 100 octets of 0 is sent alternating until it is terminated by software. (Latching only)

Link Fault Sectionalization Test Indicators

Two indicators have been added to the `rept-stat-slk` and `rept-stat-ls` commands to show whether the signaling link has a far end loopback condition and if a link fault sectionalization test is in progress.

When the signaling link is in a far end loopback condition:

- The primary state (**PST**) is **OOS-MT-DSBLD**.
- The secondary state (**SST**) is **LPBK**.
- The associate state (**AST**) is **FE**.

When a link fault sectionalization test is in progress:

- The primary state (**PST**) is **OOS-MT-DSBLD**.
- The secondary state (**SST**) is **LPBK**.
- The associate state (**AST**) is **LFS**.

When both the signaling link is in a far end loopback condition and a link fault sectionalization test is in progress:

- The primary state (**PST**) is **OOS-MT-DSBLD**.
- The secondary state (**SST**) is **LPBK**.
- The associate state (**AST**) is **FE-LFS**.

Link Fault Sectionalization Test Report

Test results are displayed to the terminal when the link fault sectionalization tests have completed. The following is an example of a link fault sectionalization test report.

Output Example

```

RLGHNCXA03W 96-04-16 16:02:05 EST Rel 21.0.0
LOC = 1205 Port = B LSN = ----- Start time = 11:10:34

PATTERN = ALTERNATE DATA= FF MAXERR = 10 TIME = 00:02:00

```

TEST STATUS = ERROR, bit error exceeded threshold.

LBP	CLLI	RLE	REP	LFST	BIT_ERROR	ERRORED_SEC	DURATION
2	rlghncxa05w	DSO	0	LLT	0	0	00:02:00
3	-----	OCU	0	NLT	8	2	00:02:00
5	-----	NEI	0	LLT	15	1	00:01:20

4.9 Link Maintenance Enhancements/LFS Increase for MPL-T and MIM (Release 31.3)

Proper functionality of a signaling link (**SLK**), from an **EAGLE MTP** card to a remote **Network Element**, is determined through a variety of mechanisms provided by **EAGLE**. This feature covers two main areas of improvement to these mechanisms. These improvements are the introduction of an operator command to force a signaling link into local line-oriented loopback and the enhancement of the **TST-SLK** command to allow for duration tests up to 24 hours.

The **LFS** Increase for **MPL-T** and **MIM** feature increases the number of simultaneously initiated **Link Fault Sectionalization (LFS)** tests on the **MPL-T**, **T1 MIM** and **CR-T1 MIM** from 1 to at least 4.

4.10 Link Status Reporting (Release 21.0)

The current method for reporting link unavailability requires the user to decipher several print outs. The first report informs the user of the link status, while subsequent reports detail the reasons for the status change. This feature provides a single report informing the user of the link unavailability with the corresponding reason. This report is generated by the `rept-stat-slk` command. If there are multiple reasons for the link becoming unavailable, the user is informed of the highest priority cause.

The `rept-stat-slk` command output is expanded to display new error codes in the Unvail Cause field for each of the link unavailability causes detailed in the following table. Two lines of information for the Unvail Cause field are displayed if conditions require it.

When an unavailability cause clears, the alarm text is displayed for the next highest priority cause.

When the last unavailability cause clears, a link available message (**UAM 200**) is displayed.

Table 4-6 21.0 Link and Link Set UAMs

UAM	Alarm	MRN in Release 21.0	Signaling Link Unavailability Priority	Abbreviation for the <code>rept-stat-slk Unvail Cause</code> field
0200	None	RCVRY-LKF : link available		
0201	Minor	REPT-LKF : remote NE loopback	1	NE

Table 4-6 (Cont.) 21.0 Link and Link Set UAMs

UAM	Alarm	MRN in Release 21.0	Signaling Link Unavailability Priority	Abbreviation for the rept-stat-slk Unavail Cause field
0202	Minor	REPT-LKF: HWP - too many link interrupts	3	INTR
0203	Minor	REPT-LKF: lost data	4	LD
0204	Minor	REPT-LKF: XER - SUERM threshold exceeded	5	XER
0205	Minor	REPT-LKF: APF - lvl-2 T1 expd (ready)	6	T1R
0206	Minor	REPT-LKF: APF - lvl-2 T1 expd(not ready)	7	T1NR
0207	Minor	REPT-LKF: APF - lvl-2 T3 expired	8	T3
0208	Minor	REPT-LKF: APF - lvl-2 T2 expired	9	T2
0209	Minor	REPT-LKF: APF - failed proving period	10	PF
0210	Minor	REPT-LKF: OSA - received SIO	11	SIO
0211	Minor	REPT-LKF: OSA - received SIN	12	SIN
0212	Minor	REPT-LKF: OSA - received SIE	13	SIE
0213	Minor	REPT-LKF: OSA - received SIOS	14	SIOS
0214	Minor	REPT-LKF: ABN - rcvd 2 of 3 invalid BSN	15	BSN
0215	Minor	REPT-LKF: ABN - rcvd 2 of 3 invalid FIB	16	FIB
0216	Minor	REPT-LKF: remote congestion timeout	17	CNGT
0217	Minor	REPT-LKF: excess acknowledge delay	18	XDA
0218	Minor	REPT-LKF: COO - rcvd changeover order	19	COO
0219	Minor	REPT-LKF: false congestion restart	20	FC
0220	Minor	REPT-LKF: MTP link restart delayed	21	RD
0221	Minor	REPT-LKF: X25 link unavailable	22	X25FL
0222	Minor	REPT-LKF: remote FE loopback	2	FE
0232	Minor	REPT-LKF: remote blocked	24	RB
0233	Minor	REPT-LNK-MANUAV: local blocked	25	LB
0234	Minor	REPT-LKF: RMI - remote inhibited	26	RMI
0235	Minor	REPT-LNK-MGTINH: local inhibited	27	LI
0236	Minor	REPT-LKF: not aligned	23	NA
0264	None	REPT-LINK-CGST: congestion level 0 to 1		
0265	None	REPT-LINK-CGST: congestion level 1 to 2		
0266	None	REPT-LINK-CGST: congestion level 2 to 3		
0267	None	REPT-LINK-CGST: congestion level 3 to 2		
0268	None	RCVRY-LINK-CGST: congestion level 2 to 1		
0269	None	RCVRY-LINK-CGST: congestion has cleared		
0270	None	REPT-LINK-CGST: discard level 0 to 1		

Table 4-6 (Cont.) 21.0 Link and Link Set UAMs

UAM	Alarm	MRN in Release 21.0	Signaling Link Unavailability Priority	Abbreviation for the rept-stat-slk Unavail Cause field
0271	None	REPT-LINK-CGST : discard level 1 to 2		
0272	None	REPT-LINK-CGST : discard level 2 to 3		
0273	None	RCVRY-LINK-CGST : discard level 3 to 2		
0274	None	RCVRY-LINK-CGST : discard level 2 to 1		
0275	None	RCVRY-LINK-CGST : discard has cleared		
0317	None	RCVRY-LKSTO : link set allowed		
0318	Minor	REPT-LKSTO : link set prohibited		

The signaling link unavailability messages use Bellcore recommended keywords in the output message. The following table shows the keywords that are supported in Release 21.0.

The signaling link unavailability messages also support Bellcore signaling link related keywords, link unavailability messages have been updated to support **SEAS** link failure cause codes shown in Section 8 of the **SEAS-STP Interface Specification, GR-310-CORE**, Issue 1, November 1994. These standard three letter codes denote the reason for link failure.

Table 4-7 Bellcore Message Keywords

Keyword	Event
REPT-XLST-TIMO	Removal of Member from X-list Due to Timeout
REPT-MTPLP-DET	MTP Loop detected: Prohibited Destination
REPT-MTPLP-SUST	Sustained Prohibited Destination Due to MTP Loop
RCVRY-MTPLP-RST	Resumption of Traffic to Loop Prohibited Destination
REPT-LKSTO	Link Set Failure
RCVRY-LKSTO	Recovery From Link Set Failure
REPT-MTP-RSTRT	Commencement of MTP Restart
REPT-STATUS-RSTRT	Progress of MTP Restart
RCVRY-MTP-RSTRT	Completion of MTP Restart
REPT-LINK-CGST	Link Congestion Level Increase
RCVRY-LINK-CGST	Link Congestion Level Decrease
REPT-LNK-MGTINH	Near End Link Management Inhibit
RCVRY-LNK-MGTINH	Near End Link Management Uninhibit
REPT-LKF	Link Failure
RCVRY-LKF	Recovery From Link Failure
REPT-LNK-MANUAV	Near End Manually Made Link Unavailable
RCVRY-LNK-MANUAV	Near End Manually Made Link Available

4.11 Linkset ID to Measurements Report (EAGLE Release 30.0/IP7 Secure Gateway Release 8.0)

Description

Currently, the **EAGLE** On-Demand Component Measurement report for the command `rept-meas:enttype=link` provides the linkset **ID** (name) for the linkset to which the link in question belongs. However, unsolicited scheduled reports of this type do not provide the linkset **ID** in the report, which can make link monitoring difficult for some customers.

The Linkset **ID** to Measurements Report feature adds the field "Linkset **ID**" to the unsolicited Component Measurement reports created with `rept-meas:enttype=link`.

Hardware Requirements

There are no hardware requirements for this feature.

4.12 Linkset Name Increase—ANSI/ITU (EAGLE Release 30.0/IP7 Secure Gateway Release 8.0)

Description

Customers may need more than 8 characters that the **EAGLE** currently allows for the linkset name. The linkset name may be used to identify the **EAGLE** and the adjacent point code and have other codes associated with it such as link speed and linkset size codes. All these attributes added up can exceed 8 characters.

The Linkset Name Increase—**ANSI/ITU** feature increases the maximum linkset name from 8 characters to 10 characters.



Note:

For **SEAS**-provisioned linksets, **SEAS** still supports a maximum of 8 characters.

Hardware Requirements

No new hardware is needed to support this feature.

Limitations

For **SEAS** verify commands that allow a wildcard for the linkset name parameter, the **EAGLE** will display all linkset names, including the ones that were entered via **EAGLE** commands and contain more than 8 characters. However, the names will be truncated to 8 characters. Therefore it may appear that there are duplicate linkset names, when each actually is unique.

Furthermore, in **SEAS**, the user cannot specify a particular linkset name that is greater than 8 characters, either for **ENT**-, **CHG**-, or **VFY**- commands. If the user tries to retrieve information about a specific linkset that appears to have duplicates, it will not be clear which is the desired linkset name from the results of a wildcard display of **VFY-LS**. The best thing for a user to do is to enter all linkset names via **SEAS**, or, if also entering them via **EAGLE**

commands, structure the names with >8 characters so as not to cause duplicates if they are truncated to 8 characters.

4.13 Linkset Restricted Support (Release 31.9)

This feature provides an optional alternate routing determination algorithm that is more tolerant during linkset transitions and reduces the likelihood of experiencing congestion on linksets that do not have a sufficient quantity of available links to carry normal traffic loads.

This feature prevents congestion on newly available linksets for **GT** routed traffic in addition to **MTP** routed traffic.

This feature supports **ITU** linksets and **ANSI** linksets.

Transfer **Restricted (TFR)** procedures support **ITU-N** linksets only if the **ITU TFR** option is turned on for the linkset. **ITU-I** linksets do not support **TFR** procedures. However, the restricted status for a route internal in the **EAGLE** still applies for **ITU** linksets when the **Isrestrict** option is on. The user can set the number of links required to a higher number just like **ANSI** linksets.

The restricted status for a route internal in the **EAGLE** still applies for **ITU** linksets when the **Isrestrict** option is on.

For routing path decisions, two factors determine what route (linkset) a message should take:

1. **Route Status. Restricted** and **Allowed** are both considered available from a routing path perspective.
2. Routing cost (ent-rte:rc=)

Currently, once the lowest cost available route is determined, it is always used. This can lead to congestion issues when the least cost Available route has a linkset status of **Restricted** (too few links available to handle the expected load). A higher cost Available route that is **Allowed** will receive no traffic, even though it may have more links available than the lowest cost Available route and would be able to handle the load without causing congestion.

The current routing determination algorithm does not use **Restricted** status when determining the preferred route. Use of the current algorithm is normally not an issue for messages not destined to the **EAGLE** (e.g., **ISUP**) but can have detrimental effects on messages destined to the **EAGLE**'s point code (e.g., **GTT** traffic). The **EAGLE** can issue **TFRs** for **MTP**-routed traffic and expect the upstream nodes to find alternate routes. However, when **GTT** traffic arrives destined for the **EAGLE**'s point code during a linkset failure, the originating node does not receive a **TFR** concerning the **EAGLE**'s point code. Therefore, **GTT** traffic will not be diverted; and when the first link in the failed linkset becomes allowed, the **EAGLE** will try to route all traffic over the newly available link. Congestion can occur due to the potentially large amounts of **GTT** traffic. This behavior is shown in the following figure.

Figure 4-4 Example of SCCP Traffic During Linkset Failures

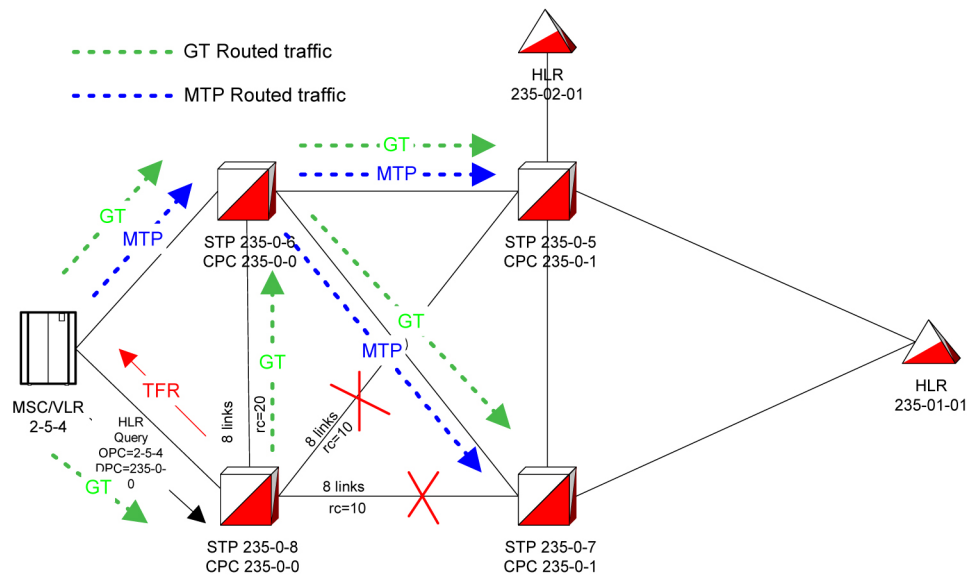

The B-linkset from **STP 235-0-8** to **STP 235-0-7** and the D-Linkset from **STP 235-0-8** to **STP 235-0-5** fail. Normally, a **TFR** would be sent to the **MSC/VLR** concerning destinations such as **HLR 235-1-1**. **MTP** traffic would be diverted from **STP 235-0-8** to **STP 235-0-6** and **STP 235-0-8** would not receive any traffic. As links become available again on the B- or D-linksets, when the threshold is specified by the **tfatcabmlq** parameter, a **TFA/TCA** is broadcast to the **MSC/VLR** and thus allow **MTP**-routed traffic to flow again through **STP 235-0-8**.

However, **GT**-routed traffic to the true point code or **CPC** of **STP 235-0-8** continues to arrive at **STP 235-0-8** and be sent over the C-linkset when the B- and D-linksets fail. The failure is caused by an affected destination of the **TFx** message. The destination tells the receiving node the point code that is allowed, restricted, or prohibited. The affected destination would not be the **EAGLE**'s point code.

When links start to become available on the B-linkset again, **GT**-routed traffic immediately starts to undergo changeback procedures, and these procedures can congest the newly available links if there are not enough links within the B-linkset to carry the normal traffic load. Again, **MTP**-routed traffic is still be diverted to the mate **STP 235-0-6** by the **MSC/VLR** until the setting in the **tfatcabmlq** parameter is met and a **TFA/TCA** is issued.

The Linkset **Restricted** Support feature changes the routing path decision process. The routing path decision process chooses a higher-cost Allowed route over a lower-cost **Restricted** route based on available link count.

Note:

NonAdjacent **Restricted** status is not used to determine when to use higher-cost routes. A route that has a linkset status of Allowed and a NonAdjacent status of **Restricted** is considered the lowest-cost available route and is used. NonAdjacent Prohibited status is still used to determine routing path decisions.

4.14 Linkset Restricted Support (Release 34.0)

The Linkset Restricted Support feature provides an optional alternate routing determination algorithm that is more tolerant during linkset transitions and reduces the likelihood of experiencing congestion on linksets that do not have a sufficient quantity of available links to carry normal traffic loads.

This feature prevents congestion on newly available linksets for **GT**-routed traffic in addition to **MTP**-routed traffic.

The route (linkset) that a message takes is determined using one of two factors:

1. **Route Status.** **Restricted** and **Allowed** are both considered available from a routing path perspective.
2. Routing cost (ent-rte:rc=)

Current routing procedures determine and use the least cost available route, regardless of whether the route is **Allowed** or **Restricted**. However, congestion can occur if too few **Allowed** links are available to handle an unexpected spike in the traffic load. While at the same time, a higher cost available route may exist that is **Allowed** and with more links available to handle the congestion, receives no traffic.

The current routing determination algorithm does not use **Restricted** status when determining the preferred route. Use of the current algorithm is normally not an issue for messages not destined to the EAGLE 5 SAS (e.g., ISUP) but can have detrimental effects on messages destined to the EAGLE 5 SAS's point code (e.g., GTT traffic). The EAGLE 5 SAS can issue TFRs for MTP-routed traffic and expect the upstream nodes to find alternate routes. However, when GTT traffic arrives destined for the EAGLE 5 SAS's point code during a linkset failure, the originating node does not receive a TFR concerning the EAGLE 5 SAS's point code. Therefore, GTT traffic will not be diverted; and when the first link in the failed linkset becomes allowed, the EAGLE 5 SAS will try to route all traffic over the newly available link. Congestion can occur due to the potentially large amounts of GTT traffic. This behavior is shown in the following figure.

Figure 4-5 Example of SCCP Traffic During Linkset Failures

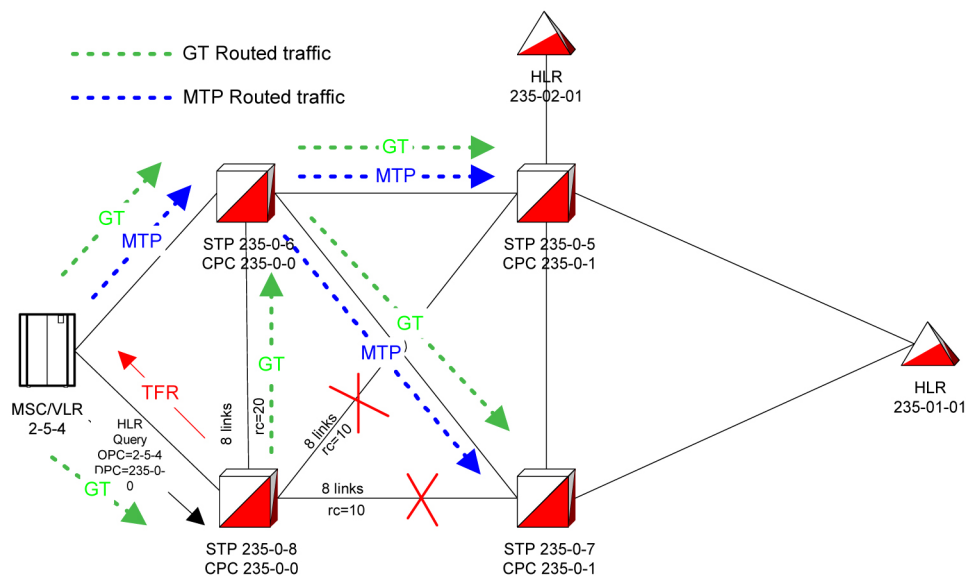

The B-linkset from **STP 235-0-8** to **STP 235-0-7** and the D-Linkset from **STP 235-0-8** to **STP 235-0-5** fail. Normally, a **TFR** would be sent to the **MSC/VLR** concerning destinations such as **HLR 235-1-1**. **MTP** traffic would be diverted from **STP 235-0-8** to **STP 235-0-6** and **STP 235-0-8** would not receive any traffic. As links become available again on the B- or D-linksets, when the threshold is specified by the **tfatcabmlq** parameter, a **TFA/TCA** is broadcast to the **MSC/VLR** and thus allow **MTP**-routed traffic to flow again through **STP 235-0-8**.

However, GT-routed traffic to the true point code or CPC of **STP 235-0-8** continues to arrive at **STP 235-0-8** and be sent over the C-linkset when the B- and D-linksets failed. **STP 235-0-8** knows that **HLR 235-1-1** is restricted, but has no method of notifying **MSC 2-5-4** to attempt to find an alternate path. Since the destination of the GT-routed traffic is **STP 235-0-8**, a **TFR** to **MSC 254** concerning **HLR 235-1-1** is ignored.

As links become available on the B-linkset again, GT-routed traffic immediately starts to undergo changeback procedures. This can congest the newly available links, if there are not enough, within the B-linkset to carry the normal traffic load. Again, **MTP**-routed traffic is still being diverted to the mate **STP 235-0-6** by the **MSC/VLR** until the setting in the **tfatcabmlq** parameter (broadcast minimum link quantity) is met and a **TFA/TCA** is issued.

The Linkset Restricted Support feature compares a linkset's available links against its provisioned links to determine if it is capable of carrying its normal load. If all or most links are available, the linkset is considered Allowed. If fewer than a specified number of links are available, the linkset may experience congestion and is considered Restricted.

Based on available link count, the Linkset Restricted Support feature alters the routing path decision process and chooses the higher-cost Allowed route instead of the lower-cost Restricted route.

For Linkset Restricted Support, while the B-Linkset is Restricted, it gets bypassed and GT-routed traffic is sent on the C-Linkset. When enough links become available for the B-Linkset to be Allowed, then B-Linkset will again be used for routing. This helps prevent congestion by ensuring that traffic gets routed on the linkset with the most available capacity.

 **Note:**

NonAdjacent **Restricted** status is not used to determine when to use higher-cost routes. A route that has a linkset status of Allowed and a NonAdjacent status of **Restricted** is considered the lowest-cost available route and is used. NonAdjacent Prohibited status is still used to determine routing path decisions.

4.15 LNP 96 Million TNs—EAGLE 5 (EAGLE Release 30.0, IP7 Secure Gateway Release 8.0)

The concepts and facilities in this section apply to the **LNP 96 Million TNs** feature, the Increase LNP **LRN** and Default **NPA-NXX** Table Capacities feature, and the Mass Update of **SPIDs** feature. For convenience of discussion, these three features are presented here.

 **Note:**

The LNP 96 Million TNs feature, the Default NPA-NXX Table Capacities feature, and the Mass Update of SPIDs feature are **EAGLE 5** features.

Overview**LNP 96 Million TNs Feature—EAGLE 5**

Customers would like to increase the database capacity of the existing 48 Million number EAGLE LNP solution. Increasing the database capacity on a single node solves several architectural issues some customers face in regionalizing their LNP solutions.

This feature increases an EAGLE single node LNP number capacity from 48 Million to 60, 72, 84, or 96 Million LNP Numbers.

 **Note:**

The existing 4G **DSM** cards will support this feature. Other variants of DSM cards (i.e. 1G, 2G, and 3G), however, are not supported.

Increase LNP LRN and Default NPA-NXX Table Capacities Feature

Currently, major hub customers, whether regionalized or centralized, potentially can run out of LRN table capacity and, more critically, default NPA-**NXX** table capacity. There is an anticipated need to increase these tables in all supported **ELAP-DSM** LNP configurations, except the 1GB (12 Million) configuration. This feature increases an EAGLE single node **LNP LRN** table to a maximum of 150,000, and the default **NPA-NXX** table to a maximum of 300,000 entries for all configurations of the **ELAP-DSM** LNP solution, excluding 1 **GB DSM** and all **TSM** variants.

Mass Update of SPIDs **Note:**

The Mass Update of **SPIDs** function is not operational unless **LSMS 6.1** is used.

This feature supports the ability to update a set of subscription and network data from one Service Provider **ID** to another. The **NPAC** (Number Portability Administration Center) provides an offline file with selection criteria for the data to be modified. The data is independently updated at the **LSMS (Local Service Management System)**; update information is not received over the **NPAC/LSMS** interface. The LSMS then creates the necessary file to transmit to the EAGLE to effect the same changes. This must be done for systems having **TSMs** or **DSMs**.

Although this feature is optional, no feature controls are required at the EAGLE; these controls are present at the LSMS.



Note:

The Mass Update of SPIDs feature is supported only on the **MPS-LSMS** interface.

Description

The **Local Number Portability** (LNP) implementation for the ELAP Application on the MPS platform consists of a Real-Time-Database (**RTDB**) component, which performs the following tasks.

- Accepts provisional transactional updates from a Local Service Management System (LSMS).
- Processes Auditing requests.
- Processes Bulk re-load request of the entire Database (DB).
- Handles Provisioning & Reload sessions to the **PROV** task.
- Services **UI** requests for Data Retrieval.

Ownership of the "golden database" resides on the LSMS, and maintains the integrity of the RTDB. All provisioning occurs on the LSMS. Additionally, the ELAP provides the ability to locally provision LNP data through the ELAP User Interface.

The following figure provides an architectural overview an LNP 48/96 Million System.

Figure 4-6 LNP 48/96 Million System Architectural Overview

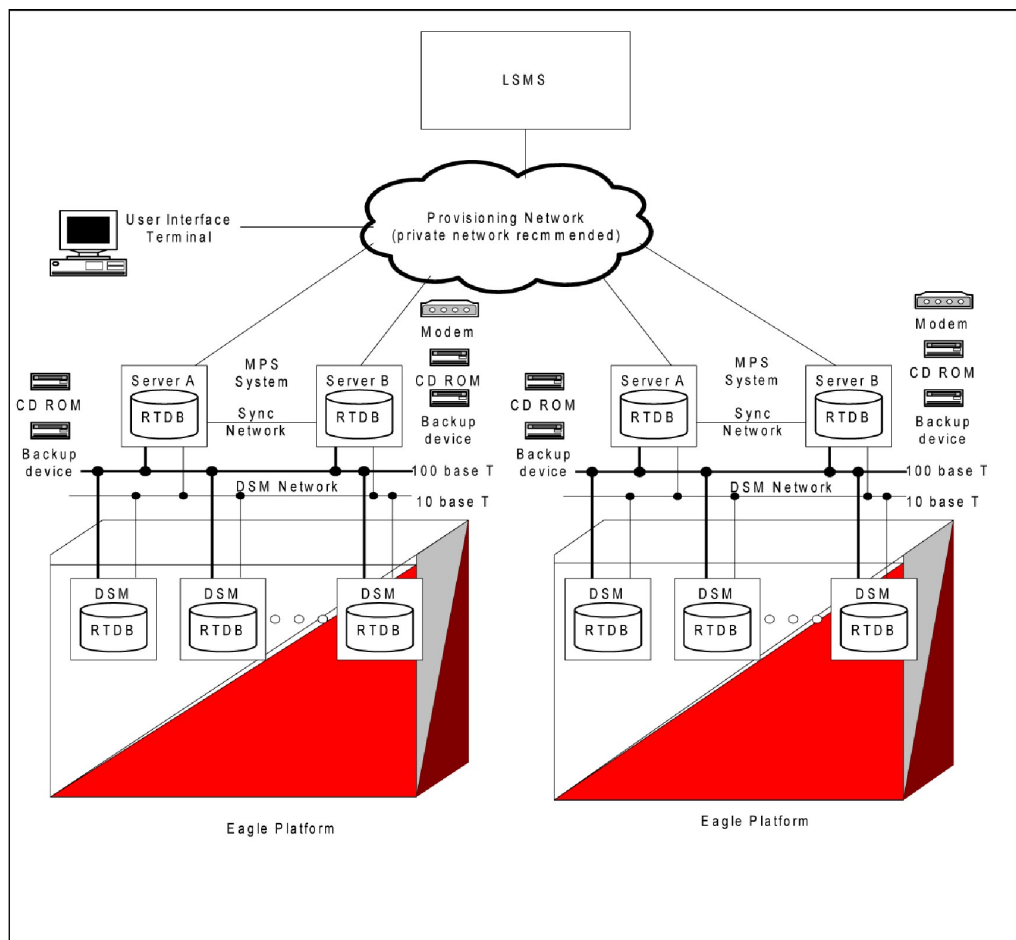

Feature Control Mechanism

This feature requires that the LNP feature be on. Previously, the mechanism for identifying this condition was to perform the EAGLE UI command `rtrv-feat` and to view the LNP component in the "ON" state. This feature employs the Feature Control Mechanism. With feature keys, the verification method for identifying the LNP feature condition is to perform the EAGLE UI command `rtrv-ctrl-feat`. If the "LNP portedTN" entry is displayed, the LNP feature is considered to be ON.

The feature key mechanism provides some additional security against mistakes and/or fraud, thereby protecting the feature assets. There is a single feature key to indicate the existence of the ELAP device. This feature key behaves similarly to the previous LNP48MIL feature bit.

The LNP ELAP Configuration feature key indicates that the **VSCCP** applications should look to the **TCPIIP** connection for the source of the LNP DB. Three additional feature keys (LNP ported TN QTY, LNP ported NPANXXs QTY, and LNP ported LRNs QTY) regulate the maximum capacity allowed within the LNP DB System.

Under the current system, neither the feature bits nor the feature keys are conveyed to the ELAP. The ELAP currently performs no regulation of the capacities within the LNP System, other than the global capacity that it can perform. The LNP 96 Million TNs Feature enforces LNP quantities on the ELAP by way of the feature keys. Loading and

maintaining the feature key table on the ELAP via the OAM accomplishes this enforcement. Therefore, the feature keys are to be provisioned solely on the OAM, and the associated keys are to be distributed to the ELAP. Synchronization occurs on the ELAP in a similar manner to that of the EAGLE LIM cards.

Upgrade routines convert feature bits to feature keys by examining the existing feature bits and SCCP hardware to determine the LNP ELAP Configuration feature key and LNP QTY levels.

Object Capacity

The maximum capacity of the objects for persistent storage is increasing; see the following table.

Table 4-8 Maximum Object Capacity

Object	LNP 12 Million	LNP 48 Million	LNP 96 Million
Telephone Number (TN)	12 Million	48 Million	96 Million.
NPANXX	150,000	150,000	300,000
Local Routing Number (LRN)	100,000	100,000	150,000

Measurements Collection

The measurements requirements remain the same as the existing LNP 12 Million and LNP 48 Million architectures, with the exception of the expanded NPANXX and LRN listed in the previous table. Measurement objects are capped at 150,000 NPANXXs and 100,000 LRNs when collection is performed via the **OAM**. When measurements are being collected by the **Measurement Platform**, the objects are capped at 300,000 NPANXXs and 150,000 LRNs.

SCCP Application Storage and Provisioning

The new LNP 96 Million TNs architecture utilizes DSM cards ranging from 1 GB to 4 GB of expanded memory. Like the existing LNP systems, the LNP 96 Million TNs feature auto-inhibits any SCCP application card that does not meet the minimum hardware requirements, based upon feature key capacities and the LNP ELAP Configuration feature keys.

Hardware Requirements

The MPS 3.0 platform is required for this feature.

DSMs

The following **DSM** configurations are supported:

Table 4-9 DSM Configuration Table for Release 30

Name	Description	Maximum Number of Ported/pooled numbers supported
DSM 1GB	DSM with 1GB populated memory and 12 Million feature access keys activated	12,000,000
DSM 2GB	DSM with 2GB populated memory and 24 Million feature access keys activated	24,000,000
DSM 3GB	DSM with 3GB populated memory and 36 Million feature access keys activated	36,000,000

Table 4-9 (Cont.) DSM Configuration Table for Release 30

Name	Description	Maximum Number of Ported/pooled numbers supported
DSM 4GB	DSM with 4GB populated memory and 48, 60, 72, 84, or 96 Million feature access keys activated	96,000,000

MPS

The **Multi-Purpose Server (MPS)** does not require additional processors, memory, and/or additional disk capacity to accommodate the requirements for the 96 Million number feature.

Enhancements to ELAP Graphical User Interface

The ELAP Graphic User Interface has been enhanced to support this feature. For more information, see *ELAP Administration Manual*.

Simplex Mode Menu Option

The new Simplex Mode menu option provides the functionality to view as well as change (i.e toggle) whether or not the ExAP is in simplex mode; see the following figure.

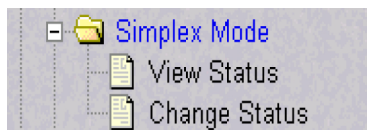
Figure 4-7 Maintenance>Simplex Mode Submenu**View Simplex Mode**

This menu selection displays whether or not the ExAP is in simplex mode state. The user requires "View Simplex Mode" action privilege to view this menu selection.

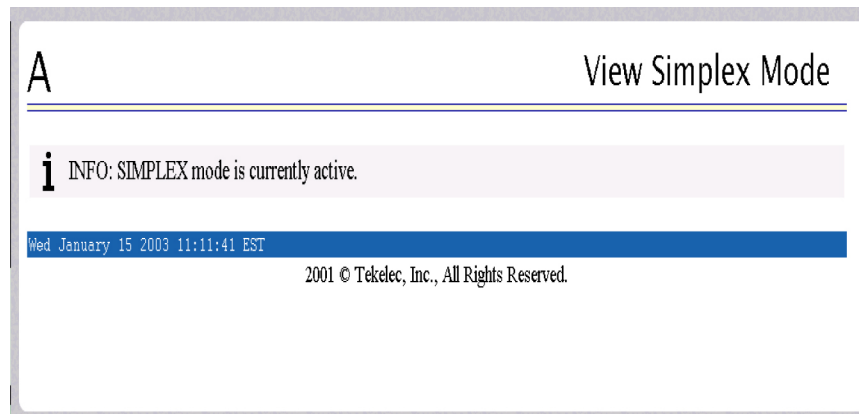
Figure 4-8 View Simplex Mode Screen

Change Simplex Mode

This menu selection toggles simplex mode on the selected ExAP.

Figure 4-9 Change Simplex Mode Screen

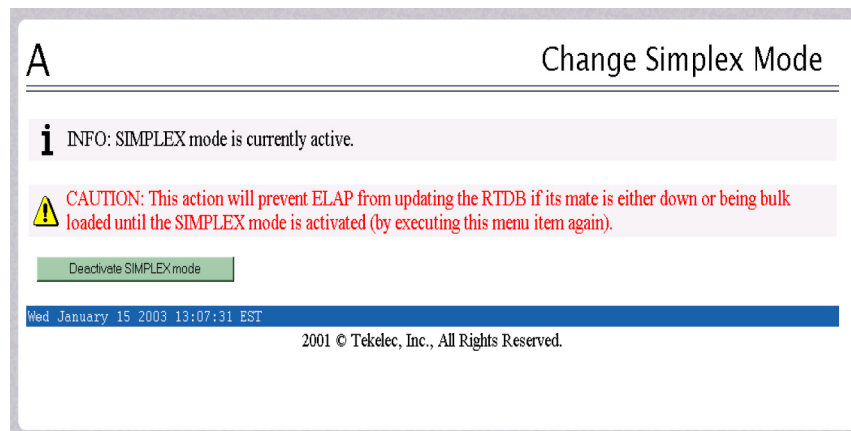

The current state of the selected ExAP is determined prior to the output of this screen. If the ExAP is not currently in simplex mode, this screen will enable the user to force it into simplex mode. If the contrary is true, the user will be enabled to remove the simplex mode condition on the selected ExAP. User requires "Change Simplex Mode" action privilege to view this menu selection.

View LNP Qty Features

This new ELAP version-only menu item selection displays the enabled LNP quantity features as provisioned on the EAGLE . The user requires "View LNP Qty Features" action privilege to view this menu selection.

Figure 4-10 View LNP Qty Features Screen

LNP Quantity Feature	Quantity Enabled
LNP ported TNs	96000000
LNP ported NPANXXs	300000
LNP ported LRNs	150000

Thu October 24 2002 17:16:50 EDT
2001 © Tekelec, Inc., All Rights Reserved.

Subscriptions

This menu option allows the user to retrieve a single subscription record using a single 10-digit subscription or an optional 10-digit subscription range as a key. If a single 10 digit

subscription is used the exact value is displayed if present, otherwise, a "not found" message is displayed.

If a 10-digit subscription range is used a start value (TN:) and end value (ETN:) must be specified and the first subscription found in the specified range is displayed if present, otherwise, a "not found" message is displayed.

Figure 4-11 Retrieve Subscription Screen



Retrieve

This menu option allows the user to retrieve a single subscription record using a single 10 digit subscription or an optional 10 digit subscription range as a key.

Figure 4-12 Retrieve Subscription Screen

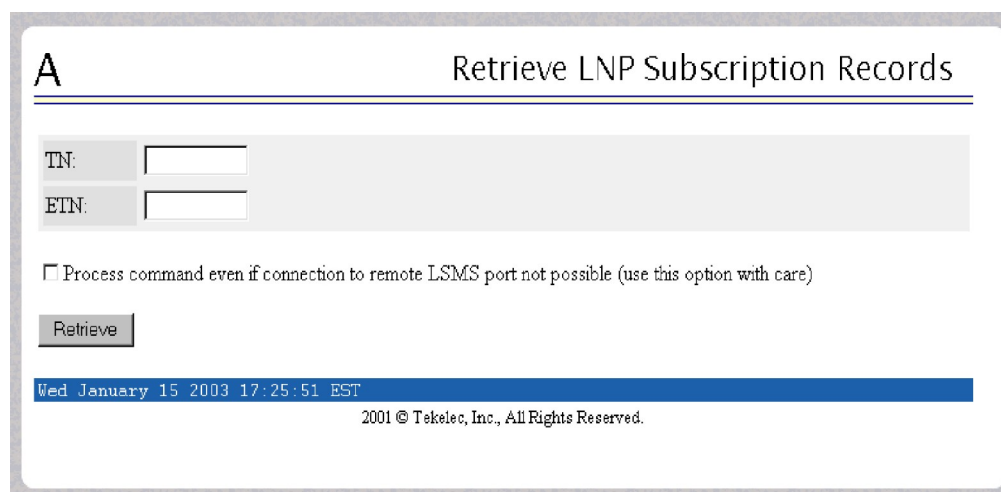

If a single 10-digit subscription is used, the exact value is displayed if present; otherwise, a "not found" message is displayed. If a 10-digit subscription range is used, a start value (TN:) and end value (ETN:) must be specified. The first subscription found in the specified range is displayed, if present; otherwise, a "not found" message is displayed.

Upgrade Considerations

EAGLE

The EAGLE upgrade must occur prior to the ELAP v3.0 upgrade. This allows for a stepwise upgrade process that will ensure “loss-less” traffic and continued service through the upgrade process. The EAGLE VSCCP-DSM application will support the legacy ELAP up to the LNP 48 Million architecture, including Warm-Restart.

The EAGLE will convert the existing LNP feature bits to feature keys as part of the upgrade conversion process. In all cases, the Feature Keys 893-0094-01 representing 150,000 NPANXXs and 893-0105-05 representing 100,000 LRN capacities will be set, except for those specifically indicated.

The next two tables show how the LNP Subscription quantities and LNP ELAP Configuration key are to be set through examining existing feature bits and **IS-NR** SCCP hardware. If conflicting feature bits and SCCP hardware are encountered during the upgrade process, the upgrade will fail during the table conversion.

Table 4-10 TSM Feature Key Upgrade Matrix

Feature Bit On	SCCP Hardware IS-NR			
	TSM-256 MB	TSM-512 MB	TSM-768 MB	TSM-1024 MB
LNP	893-0110-01 (2M TNs)	893-0110-02 (4M TNs)	893-0110-03 (6M TNs)	893-0110-04 (8M TNs)
LNP12MIL	¹ N/A	N/A ^a	N/A ^a	893-0110-05 (12M TNs)
² LNP18MIL	N/A ^a	N/A ^a	N/A ^a	N/A ^a
LNP48MIL	N/A ^a	N/A ^a	N/A ^a	N/A ^a

¹ These cards will be auto-inhibited and not detected during the upgrade process.

² **LNP18MIL** is an Obsolete Feature Configuration and should not be present in the field.

Table 4-11 DSM Feature Key Upgrade Matrix

Feature Bit On	SCCP Hardware IS-NR			
	DSM-1 GB	DSM-2 GB	DSM-3 GB	DSM-4 GB
LNP	893-0110-04 (8M TNs)	893-0110-04 (8M TNs)	893-0110-04 (8M TNs)	893-0110-04 (8M TNs)
LNP12MIL	893-0110-05 (12M TNs)	893-0110-05 (12M TNs)	893-0110-05 (12M TNs)	893-0110-05 (12M TNs)
LNP18MIL ^b	N/A ^b	N/A ^b	N/A ^b	N/A ^b
LNP48MIL	893-0109-01 (ELAP)	893-0109-01 (ELAP)	893-0109-01 (ELAP)	893-0109-01 (ELAP)
	893-0110-05 (12M TNs)	893-0110-06 (24M TNs)	893-0110-07 (36M TNs)	893-0110-08 (48M TNs)
	893-0105-05 (100k LRNs)	893-0105-01 (150k LRNs)	893-0105-01 (150k LRNs)	893-0105-01 (150k LRNs)
	893-0094-01 (150k NPAs)	893-0094-02 (300k NPAs)	893-0094-02 (300k NPAs)	893-0094-02 (300k NPAs)

ELAP

The ELAP v3.0 upgrade must occur after the EAGLE v30.0 upgrade has occurred. This is to allow the EAGLE v30.0 time to soak with upgraded hardware such as **GPSM-II** and HMUX. During the ELAP upgrade process the RTDB database will be moved from its current location `/usr/rt` to the `/usr/db` location in preparation for the upgrade process and allows for back-out capabilities.

Once the LNP 48 Million tables are located in the `/usr/db` directory, new LNP 96 Million TNs architecture tables are created and populated through conversion of the old data. This avoids the Bulk Download procedures from the LSMS in order to populate the new architecture. Once conversion has occurred on one ELAP, it can then be loaded from the mate as part of the mate upgrade.

When upgrade of the ELAPs are complete, the DSM connection will be re-established. Once the ELAP-DSM connection is re-established, the VSCCP-DSM application will recognize the architectural change and set all connected DSM cards to **INCONSISTENT**. This will allow for continuation of LNP queries from the protocol, yet prevents any further DB updates. By re-booting the SCCP application, the reloading of data will take on the new architecture.



Note:

This specifically entails that a **COLD** re-start will occur on each DSM card being reloaded with the new 96 Million architecture, regardless of the LNP quantity setting in the feature key.



Note:

An ELAP v3.0 is not structurally compatible with and EAGLE Release v27, 28 and 29 (pre release 30.0); therefore it must not be connected in that configuration.

The steps involved in performing the upgrade are specific to maintaining provisioning capability to the EAGLE **DSM** cards at all times, starting with ELAP v1.0 or v2.0 units operating in duplex mode.

- **Maximum NPANXX Objects**
The maximum NPANXX objects is capped at 300,000 NPANXXs. Although feature keys have been allocated for further expansion in the future, they will not be permitted to be provisioned.
- **Maximum NPANXX Objects**
The maximum LRN objects is capped at 150,000 LRNs. Although feature keys have been allocated for further expansion in the future, they will not be permitted to be provisioned.
- **OAM-based Measurements Subsystem**
The OAM-based Measurements Subsystem will not support the LRN and NPANXX increase to 150,000 and 300,000 entries, respectively. The OAM will collect and report 100,000 LRNs and 150,000 NPANXXs only.

The NPANXXs reported will be the first 150,000 provisioned NPANXXs. Collection data for the remaining 150,000 NPANXXs will be discarded.

The LRNs reported will be the first 100,000 provisioned LRNs. Collection data for the remaining 50,000 LRNs will be discarded. Note that this could result in a significant change in the reported data set, if provisioning occurs during upgrade.

- OAM Upgrade

The OAM Upgrade will not execute if LNP18MIL = ON and LNP48MIL = OFF. Although this is a condition carried over from the LNP 18 Million TN feature (which became obsolete in EAGLE Release 27.0), it still may be encountered. In this event, the upgrade will return a failure, and will not continue until the LNP48MIL feature bit is turned ON.

4.16 LNP AIN Query Enhancement (PR28376) (Release 26.0)

Currently, the **LNP AIN** solution does not preserve the Charge Number and Charge Party Station type in the **LNP AIN** query and response. Without these parameters, **SSP**'s cannot set up calls to **IC** type trunk groups.

With this enhancement, the **EAGLE STP**'s **LNP** solution provides the ability to copy Charge Number and Charge Party Station type parameters from the **LNP AIN** query to the **LNP AIN** response. This capability is accessed on a per-**STP** basis via the **LNPOPTS**.

4.17 LNP Measurements Enhancements (Release 25.0)

Overview

This feature adds additional per **SSP** measurements for **LNP** Queries and for **LNP** Message Relay. It splits existing per **SSP** measurements into ported and non-porting measurements, and it adds Message Relay measurements for **CNAM** and **ISVM** messages to the existing **LIDB** and **CLASS** Message Relay measurements.

Message Relay Measurements per SSP

The following message relay measurements are pegged per **SSP**:

1. **LIDBGTP** - Ported **LIDB** transactions, per originating **SSP**
2. **LIDBGTNP** - Non-Ported **LIDB** transactions, per originating **SSP**
3. **CLASSGTP** - Ported Class transactions, per originating **SSP**
4. **CLASSGTNP** - Non-Ported Class transactions, per originating **SSP**
5. **CNAMGTP** - Ported **CNAM** transactions, per originating **SSP**
6. **CNAMGTNP** - Non-Ported **CNAM** transactions, per originating **SSP**
7. **ISVMGTP** - Ported **ISVM** transactions, per originating **SSP**
8. **ISVMGTNP** - Non-Ported **ISVM** transactions, per originating **SSP**

For the above counts, Ported means Successful 10 digit translations; non-Ported means an aggregate of the following:

- Successful 6 digit translations (non-porting numbers in portable **NPA-NXX**) either default **GTT** or normal **GTT**
- Successful 6 digit translations (non portable numbers) normal **GTT**

- Failed 6 digit translations (no **GTT** entry matched)

 **Note:**

Only **MSUs** with valid and supported parameters are pegged.

The originating **SSP** is derived from:

1. Calling Party address in the **SCCP** header. The point code must exist and the **RI** must **NOT = GT**.
2. **OR** the **OPC** of the **MTP** routing label.

This implementation will peg measurements under the above circumstances for any **ANSIUDT** or **UDTMSU** requiring global title.

For backwards compatibility, the following counts also are maintained on disk. These counts are the sum of the ported and non-ported measurements for that service:

1. **LIDBGTRQ** - Total **LIDB** transactions, per originating **SSP**
2. **CLASSGTRQ** - Total Class transactions, per originating **SSP**

$$\mathbf{LIDBGTRQ = LIDBGTP + LIDBGTNPCLASSGTRQ = CLASSGTP + CLASSGTNP}$$

The following figure illustrates the various subsystems involved in the **EAGLE/LNP**. The shaded boxes represent the subsystems affected by these new measurements. For measurements purposes all **GTT** measurements occur with the **SCRC** application, regardless of whether the **MSU** is a routine **GTT** or **MRGTT**. The transactions are recorded for **LNPMR** service and regular **GTT** entries.

 **Note:**

Only **MSUs** with valid **GTT** parameters and format are pegged.

Figure 4-13 LNP Block Diagram

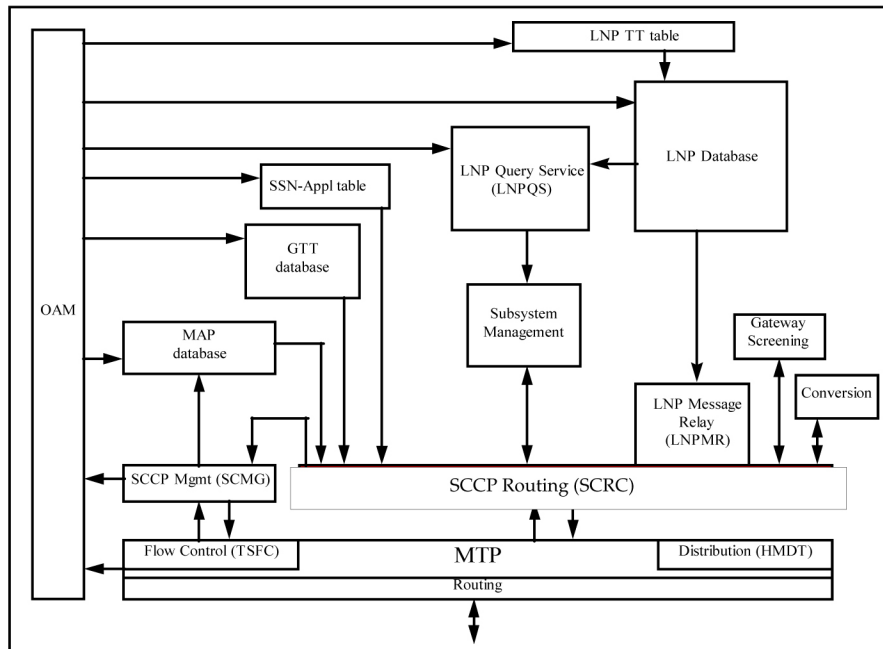

Message Relay Measurements per SSP

Limitations for Message Relay Measurements

1. Only valid **GTTMSUs** are pegged. The following conditions are considered invalid **MSUs**:
 - a. **SCCP** called **SSN** not included in **MSU**,
 - b. Called party **GT** indicator not equal to 0010 (**TT** only)
2. **ITUMSUs** are not pegged.
3. **CLASS**, **LIDB**, **CNAM**, and **ISVM** translations are recorded *only* if the **TT-SERV** table is provisioned with **CLASS**, **LIDB**, **CNAM**, and **ISVMTT** values
4. These measurements are recorded per originating **SSP** only so far as the point code exists in the provisioned routing table data base.
5. If the originating **SSP** does not have a full **PC** entry in the routing table, but does have a cluster entry, the measurement will be pegged for the cluster entry.

LNP Query Measurements per SSP

Before Release 25.0, the number of **LNP** Queries processed per **SSP** were pegged. Beginning with Release 25.0, this count is broken into two separate counts:

1. **SSPQRCVP** - Ported **LNP** Queries processed, per originating **SSP**
2. **SSPQRCVNP** - Non-Ported **LNP** Queries processed, per originating **SSP**

These measurements are pegged only if the message goes to **EAGLE**'s **LNP** subsystem. The message must also be formatted correctly.

The following types of **LNP** Queries are pegged:

- **AIN** Queries

- **IN** Queries
- Wireless **LNP** Queries
- **Triggerless LNP** Messages (**ISUPIAM** messages intercepted by **TLNP**)

The originating **SSP** is derived from:

1. Calling Party **Point Code** in the **SCCP** header (**AIN**, **IN**, and **WLNP** Only). The point code must exist and the **RI** must **NOT = GT**.
2. **OR** the **OPC** of the **MTP** routing label.

The originating **SSP** must be in the routing table, or the measurement will not be pegged. If the originating **SSP** does not have a full **PC** entry in the routing table, but does have a cluster entry, the measurement will be pegged for the cluster entry.

For backwards compatibility, **SSPQRCV** - the count of Total Queries processed, per originating **SSP**, will also be maintained on disk. This count is the sum of the ported and non-ported **LNP** Queries processed.

SSPQRCV = SSPQRCVP + SSPQRCVNP

Collection

These new measurements are added to the existing per **SSPLNP** measurements data maintained hourly and daily. The data is collected along with the existing per **SSP** data from all **SCCP** cards.

Storage

The per **SSP** measurements tables on disk are replaced with enhanced tables to store the additional registers.

Upgrade Considerations

The new software accommodates the old database during the upgrade. The new fields for the existing tables, such as the **NCR** bit in the feature table, defaults to 0 (**OFF**), and the **NCAI** parameter in the destination table defaults to 0 (**NO**).

Use the `rtrv-dstn` command to verify the status of the **NCAI** parameter (it should display `ncai = no` for existing cluster destinations). To activate the Nested **Cluster** Feature, the software release must contain the **CRMD** feature (non-nested cluster management).

4.18 LNP Message Relay Enhancement (PR28810) (Release 26.0)

In Release 24.0, a change was implemented to address a non-conformance to the **LNP** message relay function. This change involved discarding a message if it was related to a ported **TN**, with **LRN** override data provisioned, but not for the specific service. This change has resulted in these customers provisioning default service data into the override tables to continue this type of **LNP** message relay service portability functionality.

In order to address the needs of these customers while continuing to provide the enhanced solution, in Release 26.0 the **EAGLE** will allow for either method of operation for **LNP** message relay on a per **STP** basis.

Figure 4-14 Example Network

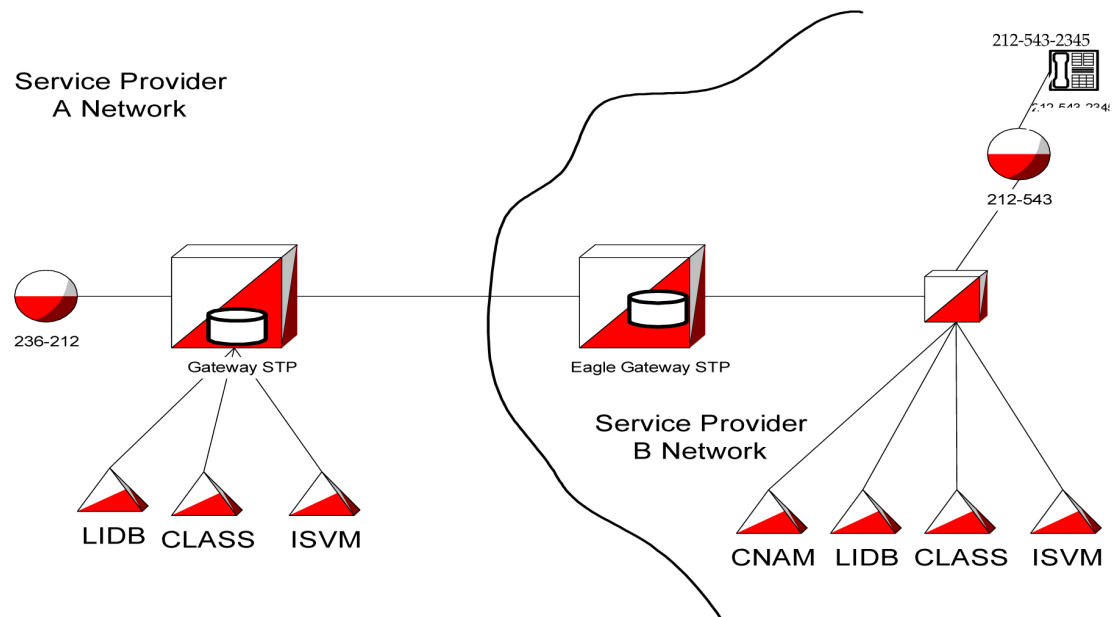

Consider the network depicted in the figure. If customer 212-543-2345 ports from Service Provider B to A, Service Provider A needs to provide **CNAM** functionality, as it does not provide **CNAM** service within its network. However, Service Provider B can potentially "resell" **CNAM** service to Service provider A. The **EAGLE LNP** subsystem for Service Provider B would require that only the override **GTT** for the **CNAM** service be provisioned at the **STP**. Calls from the customer requiring **LIDB** service that originate in Service Provider's B network would arrive at Service Provider's B **EAGLE** Gateway **STP**.

Since 212-543-2345 is ported out, the override **GTT** data is first used. If the override data contains only data for **CNAM** service, the **EAGLE** formerly used the default data in the **NPAC** subscription information for **LIDB** and route the query to Service Provider A's Gateway **STP**.

This functionality was changed so that individual services would not default to the **NPAC** subscription data if the override **GTT** data was provisioned for one service, but was missing for another service. Due to this change, if Service Provider B wanted to route the **LIDB** query to Service Provider A's gateway **STP**, Service Provider B would have to provision the **NPAC** default data into the override table in order not to reject the **LIDB** query. This could cause unacceptable provisioning requirements for Service Provider B.

4.19 LNP Response to STPLAN (PR28660) (Release 26.0)

Currently, **STPLAN** functionality does not include **LNP** responses generated from the **EAGLE LNP Database**. This is due to the fact that the response is an **EAGLE**-generated **MSU** that does not have the **STPLAN** copy flag set.

With this feature, the **LNP** Query Service application now supports the copying of **LNP** response messages to the **STP/LAN** application. All **LNP** response messages will have the **GWS** Action Set **ID** set to the value of the corresponding **LNP** query message. This ensures that all **LNP** query messages that passed gateway screening with the **STOP©** action set will have their responses copied to **STPLAN**.

The **LNP** response messages that are copied to **STP/LAN** are:

- **AIN**
- **IN**
- **TCAP** Error Response
- Wireless **LNP**
- **PCS 1900**

4.20 LNP Short Message Service (Release 28.2)

Description

EAGLE LNP currently supports the message relay function. **LNP** Short Message Service is an additional service offered in the message relay function. The **DPC/SSN** for the **WSMSC** is provisioned in the subscription versions received from the **NPAC** via the **LSMS**. This feature incorporates interface, administration, and protocol changes. All functions of the core **LNP** message relay feature are supported for the new **LNP** Short Message service. The **LNP** Short Message Service is unique, in that the service is supported for two protocols, **ANSI-41** and **PCS1900**.

All **EAGLEs** must be upgraded to the **LNP SMS** capable release prior to configuring the **LSMS** to send **WSMSC** data in the subscription version. The **LNP SMS** capable **EAGLE** release will be capable of receiving subscription versions with and without **WSMSC** data. This allows the **EAGLEs** to operate without receiving **WSMSC** data, until all **EAGLEs** are upgraded and the **LSMS** configuration change is made.

Protocol

Message relay operates on **GTT** messages with translation types administered as "**LNP Services**." The 10-digit ported number is extracted from the message, and used to perform a lookup in the **LNP** database. If the ported number is found, the appropriate ported number or **LRN** override routing information is used to route the message. If the number is not found, default **GTT** data is used, if provisioned. Otherwise, the traditional (non-**LNP**) global title function is performed, using all the digits present in the **SCCP** layer.

To perform the lookup, the 10-digit dialed number (**NPA-NXX-XXXX**) is required as the key. Two protocols are supported for the **WSMSC** support, **ANSI-41** and **PCS1900**. For **ANSI-41**, the **WSMSC DPC/SSN** in the subscription version locates the Message Center. For **PCS 1900**, the **WSMSC DPC/SSN** locates the **HLR**. The subscription version contains one set of **WSMSC DPC/SSN** data. Therefore, incoming messages with different **TTs** may resolve to the same information in the **TN** record, using **TT** aliasing.

Hardware Requirements

No new hardware is needed to support this feature.

Note:

This feature requires the **MPS** and **DSMs** on the **EAGLE** (i.e. 48 Million Number Architecture). This feature also requires the corresponding feature on the **LSMS**.

Measurements

Two new Measurements Registers have been added to the **LNP SSP** report.

Table 4-12 LNP Short Message Service Measurements Registers

Name	Description
WSMSCGTP	Number of WSMSC Global Title Translations for ported TNs received per originating SSP .
WSMSCGTPN	Number of WSMSC Global Title Translations for non-porting TNs received per originating SSP .

These new **LNP SMS** Measurements Registers are supported for two protocols: **ANSI-41** and **PCS 1900**. Also, they are supported with and without the Measurements Platform feature enabled. If the Measurements Platform feature is not enabled, the **LNP SSP** report is generated to the **FTA** area from which it can be downloaded via Kermit. If the Measurements Platform feature is enabled, the **LNP SSP** report is transferred to an **FTP** server.

4.21 LNP—10 Digit Telephone Number Subscription Commands (Release 22.0)

Refer to the *Commands Manual* for current usage information.

`ent-lnp-sub`

The `ent-lnp-sub` command is used to add an **LNP** 10 digit ported telephone number and its **LNP** query **LRN** or message relay global title information to the database.

`dlt-lnp-sub`

The `dlt-lnp-sub` command is used to remove an **LNP** 10 digit ported telephone number message relay service, **LRN**, or the entire telephone number subscription from the database.

`chg-lnp-sub`

The `chg-lnp-sub` command is used to change the attributes of an existing 10 digit telephone number subscription. The `chg-lnp-sub` command uses these parameters.

`rtrv-lnp-sub`

The `rtrv-lnp-sub` command displays all the **LNP** 10 digit ported **TNs** and their assigned services in the database.

`dlt-lnp-serv`

The `dlt-lnp-serv` command is used to remove an **LNP** service from the database.

`chg-lnp-serv`

This `chg-lnp-serv` command is used to change the attributes of an existing **LNP** service using the `chg-lnp-serv` command.

4.22 LNP—Allow Subsystem Command (Release 22.0)

The `alw-ss` command is used to bring a mated application subsystem back into service. This command uses only one parameter, `ssn`, the mated application subsystem number. This command can only be executed when the current state of the mated application subsystem is **OOS-MT-DSBLD** and the subsystem is online. When the subsystem has been successfully placed back into service, the primary maintenance state of the specified mated application subsystem is set to **IS-NR** (in service normal).

4.23 LNP—Automatic Call Gapping (Release 22.0)

Automatic call gapping controls the rate that location routing number (**LRN**) queries for a particular telephone number or a portion of a telephone number are received by the **EAGLE LNP** when a particular threshold is reached. **ACG** controls are used under two conditions:

1. When a node overload condition is detected and an **ACG** control is configured for that overload level, the **EAGLE LNP** sends an **ACG** component within each **LRN** query response it processes. The **ACG** control is invoked for the first 6 or 10 digits of the called party address in all queries sent to the **EAGLE LNP** to control the rate that queries are processed.
2. If no overload control is sent, the **EAGLE LNP** sends an **ACG** for a manually initiated control to control the rate of queries for a particular area code (3 digits), area code and prefix (6 digits), 10 digit telephone number, or part of a 10 digit telephone number (6 to 10 digits) are processed. The database can contain a maximum of 256 manually initiated **ACG** controls.
3. Refer to the *Database Administration Manual - LNP* for the current details of this feature.

4.24 LNP—Automatic Call Gapping Commands (Release 22.0)

Refer to the *Commands Manual* for current usage information.

`ent-acg-nog` The `ent-acg-noc` command is used to add an **ACG** node overload control level to the database.

`dlt-acg-noc` The `dlt-acg-noc` command is used to remove an **ACG** node overload control level from the database. The `dlt-acg-noc` command uses only one parameter, `lvl` - the overload levels 1 through 9. The database contains 10 **ACG** node overload levels, but only nine are configurable.

`chg-acg-noc` The `chg-acg-noc` command is used to change the values of an existing **ACG** node overload control level in the database.

`rtrv-acg-noc` The `rtrv-acg-noc` command displays the definitions of the node overload levels in the database. The definition is comprised of the threshold **LNP** query rates for node overload levels and the values for the **ACGs** to be sent when at the level. The `rtrv-acg-noc` command uses one parameter, `lvl`, to display a specific node overload level.

`ent-acg-mic` The `ent-acg-mic` command is used to assign **ACG** controls to all **LNP** queries or to specific **LNP** query services and called party digits. If the **EAGLE LNP** query service receives a query to which a control applies, then the **EAGLE LNP** sends an **ACG**, encoded as configured, with the response.

`dlt-acg-mic` The `dlt-acg-mic` command is used to remove an **ACG** manually initiated control.

`chg-acg-mic` The `chg-acg-mic` command is used to change an existing **ACG** manually initiated controls .

`rtrv-acg-mic` The `rtrv-acg-mic` command displays the values of **ACG** controls assigned to certain queries. The control can apply to all queries or to specific query services and called party digits. A set of controls is selected to be displayed by specifying the `type` of control(s), the service (`serv`), and/or the digits (`dgts`).

4.25 LNP—Call Completion to Ported Number (CCPN) (Release 22.0)

This capability allows the call to be completed to a telephone number that has been moved from one switch to another, a ported number. When a call is placed to a ported telephone number, the switch where the number used to reside sends a query to the **LNP** database to obtain the location routing number (**LRN**). The **LRN** gives the location of the new switch that the telephone number resides on. When a response to the query is returned to the old switch, the call is completed using the **LRN** to route the call to the new switch. To implement this capability, these features are required.

- **LRN** query processing - services **LRN** queries in real time and generates the appropriate **LRN** response. Multiple query types are supported.
- **SMS** interface - the **SMS** interface is required for **LNP** database management from an **SMS** system.
- **ACG** control - Automatic call gapping is required for overload control when an excessive number of **LRN** queries are received for a number.
- Local subsystem management - The **LNP** query processing application is implemented as a local **SCCP** subsystem and local subsystem management functions are performed in the **EAGLE LNP**.

4.26 LNP—Change Database Command (Release 22.0)

A new action, `import`, has been added to the `action` parameter of the `chg-db` command. The `action=import` parameter restores selected portions of the current **LNP** database from a removable cartridge created by the **LSMS**. If the **EAGLE LNP**'s database becomes severely out of sync with the **LSMS**'s **LNP** database, the `chg-db:action=import` command can be used to resynchronize the **LNP** portion of the database with the **LSMS**.

The removable cartridge containing a copy of the **LSMS**'s **LNP** database, formatted in **EAGLE** database format, is created at the **LSMS**. The action of the `chg-db:action=import` command is similar to the action of the `chg-db:action=restore:src=remove` command, except that only these tables in the **LNP** portion of the database are replaced.

- `servprov.tbl`

- `lnp_stat.tbl` (only a portion of this table is imported)
- `lnp_lrn.tbl`
- `lnp_mr.tbl`
- `lnp_npa.tbl`
- `lnp_4dig.tbl`
- `lnp_dbmm.tbl`

After the `chg-db:action=import` command has completed, this minor alarm is raised for all operational **TSMs** showing that the **TSMs** must be reinitialized to use the newly imported **LNP** data.

```
* 5022.0429 * CARD xxxx SCCP LNP database is inconsistent
```

When the `chg-db:action=import` command has completed successfully, both the active and standby **MASPs** are reinitialized.

4.27 LNP—Changes to Existing Commands (Release 22.0)

LNP—Self ID Commands

The `cpctype` parameter has been added to the `chg-sid` command to define the type of capability point code being added to the self **ID** of the **EAGLE LNP**. The **EAGLE LNP** can contain two types of capability point codes, **LNP** and **STP**. If the `cpctype=lnp` parameter is specified, the capability point code must be an **ANSI** point code. The **LNP** capability point codes are used to associate a specific **LNP** service or capability (for example, **Local Number Portability** Query Response and Message Relay service) with one or more of the capability point codes in the self **ID** of the **EAGLE LNP**. If the `cpctype=stp` parameter is specified, the capability point codes can be an **ANSI**, **ITU** international, or **ITU** national point code. The self **ID** of the **EAGLE LNP** can contain a maximum of 96 capability point codes.

The **CPCA (LNP)** field has been added to the output of the `rtrv-sid` command to display the **LNP** capability point codes contained in the self **ID** of the **EAGLE LNP**. The `cpctype` parameter has been added to the `rtrv-sid` command to display either the **LNP** capability point codes (`cpctype=lnp`) or the **STP** point codes (`cpctype=stp`).

LNP—Mated Application Commands

The `ent-map` and `chg-map` commands have been changed to allow the **EAGLE's** true point code and the **LNP** subsystem number to be entered into the mated application table, if the **LNP** feature is turned on. When the **LNP** subsystem number is specified, the multiplicity indicator can be either solitary (`mult=sol`) or dominant (`mult=dom`). If the **LNP** feature is not on, the point code specified in these commands must be in the routing table.

LNP—chg-feat and rtrv-feat Commands

The `lnp=on` parameter has been added to the `chg-feat` command to turn the **LNP** feature on. To show whether the **LNP** feature is on, the **LNP** field has been added to the `rtrv-feat` command output.

Before the **LNP** feature can be turned on, the global title translation feature must be on and the **EAGLE LNP** must be configured with this hardware.

- **TSM** - P/Ns 870-1289-xx, 870-1290-xx, 870-1291-xx, 870-1292-xx
- **MCAP** card - P/N 870-1307-xx

 **Note:**

Once any feature is turned on with the `chg-feat` command, they cannot be turned off.

4.28 LNP—clr-disk-stats Command (Release 22.0)

The `clr-disk-stats` command is a debug command used to clear the disk performance statistics and set all the disk performance statistic fields to 0. This command uses only one parameter, `loc` - the card location of the **MASPs**, either 1113 or 1115.

4.29 LNP—Degraded Mode (Release 22.0)

For the **LNP** application, software loading has been modified to verify the validity of the hardware configuration for both **MASP** and **SCCP** cards. The **MASP** hardware configuration is verified first. Once **MASPs** configuration is determined to be valid, then the **SCCP** hardware configuration is verified. The hardware configuration for **MASP** and **SCCP** cards is verified only when the **LNP** feature is turned on. The verification of the hardware includes:

- validity of the main assembly
- verification of applique's memory size

When the hardware configuration for the **MASP** is determined to be invalid for the **LNP** feature, the **MASP** enters a degraded mode. Degraded mode inhibits some **MASP** functionality in hopes of preventing more serious system fault conditions.

When the hardware configuration for an **SCCP** card is determined to be invalid for the **LNP** application, **SCM** automatically inhibits loading for that specific **SCCP** card. A minor alarm is generated indicating that card loading for that **SCCP** card has failed and has been automatically inhibited (i.e. prevented from reloading again). When card loading has been inhibited, the primary state of the card is set to **OOS-MT-DSBLD** and the secondary state of the card is set to **MEA** (Mismatch of Equipment and Attributes).

To activate loading of an **SCCP** card which has been automatically inhibited, enter the `alw-card` command. The `alw-card` command is rejected if the **LNP** is in degraded mode.

Degraded mode is entered under any of these situations:

- Active and standby **MASPs** do not have an E586 main assembly and an applique with a minimum of 256 Mbytes of memory.
- Any **IS-NR SCCP** card does not have an E586 main assembly and an applique with a minimum of 256 Mbytes of memory.

The following actions are taken during degraded mode:

- **LNP** database commands for configuring **LNP** data in the database is rejected. Retrieve commands is accepted.

- Loading of **SCCP** cards is disabled. **SCCP** cards requesting to be loaded will have loading automatically inhibited. **SCCP** cards already in service continue to run.
- The **LNP** subsystem is prevented from going online. (any attempt to execute the `alw-map-ss` is rejected). The **LNP** subsystem can be taken offline (the `inh-map-ss` is accepted).
- The **PST/SST** of each **MASP** with an invalid configuration is set to **IS-ANR/MEA**.
- The `rept-stat-sys` command output shows that the **EAGLE** is in degraded mode.

The method to recover from degraded mode is dependent upon the reason degraded mode was entered. The list below defines method(s) to recover from degraded mode for each possible reason the mode can be entered.

- The active and standby **OAMs** do not have the correct main assembly/applique combination.
Change the **MASP** hardware configuration to an E586 main assembly with a minimum of 256 Mbytes of memory on the applique.
- An **SCCP** card does not have the correct main assembly/applique combination.
Change the **SCCP** hardware configuration to an E586 main assembly with a minimum of 256 Mbytes of memory on the applique.

4.30 LNP—Destination Point Code Exception Report (Release 23.1)

The **EAGLE** requires that the destination point code contained in the global title translation data in the database has a route assigned to it so the **MSU** can be routed to the destination point code. The **LNP** subscription data the **EAGLE** receives from the **LSMS** can contain global title translation data with destination point codes that do not have routes assigned to them in the **EAGLE** database. Normally this type of data would be rejected since the **EAGLE** does not know how to route to the destination point code. However, since this data is coming from the **LSMS** for **LNP** updates, the **EAGLE** must accept it.

This feature generates a report of **LNP** subscriptions in the database whose destination point codes have not been assigned to a route. Two types of reports are generated:

- All destination point codes in the **LNP** database that are not assigned to a route.
- For each telephone number, all destination point codes in the **LNP** database that are not assigned to a route.

4.31 LNP—disp-disk-stats Command (Release 22.0)

The `disp-disk-stats` command is a debug command that displays the disk performance statistics. The **MASPs** maintain disk read/write access times as well as statistics for each table and application showing the number of disk accesses and cache accesses. The application and table statistics that have zero values will not be output if an application **ID** or table **ID** is not specified; only non-zero statistics are displayed in the default report.

Refer to the *Commands Manual* for current usage information.

4.32 LNP—EAGLE LNP Configuration (Release 22.0)

The **EAGLE LNP** uses the same platform as the **EAGLE STP**, but with these changes.

The **LNP** data is stored on the fixed disk drive on the **TDM**. The fixed disk is partitioned to store both the **LNP** data and the **STP** data to prevent a failure of either database from affecting the other. The **LNP** data is downloaded from the fixed disk drive to the **TSM**, an **ASM** containing 1 Gbyte of memory. The **TSM** is made up of an E586 main assembly and 4 **M256** appliques. Each **M256** applique contains 256 Mbytes of memory.

To configure an **EAGLE LNP** for the **LNP** feature, these software changes have been made.

- The **LNP** feature must be turned on with the `chg-feat` command. No **LNP** commands can be executed if the **LNP** feature is not turned on. The **LNP** feature cannot be turned on if the **SCCP** memory (**ASM** or **TSM**) is not large enough to hold the **LNP** data.
- If a **TSM** card is loading data, **LNP** data cannot be configured until the loading process has completed.
- The **LNP** database is audited every 24 hours.

The **LNP** database contains this data.

- Six global title translation services requiring message relay service. This data is received from the **LSMS**.
- Default global title translation for each ported **NPANXX**. This data is received from the **LSMS**.
- A list of ported **NPANXX** requiring **SCCP** message relay service at the **EAGLE LNP**. This data is received from the **LSMS**.
- An indication for each translation type (applicable for only ported **NPANXXs** requiring **LIDB**, **CLASS**, **ISVM**, and **CNAM** message relay service) indicating if **SCCP CDPA** includes 10 digits. The default is “Yes.” This indicator is used only when the length of the **SCCP CDPA** is 10 digits, but only 6 digits are included. If the length of the **CDPA** is 6 digits, this indicator is ignored. This data is received from the **LSMS**.
- Six digit global title translation for **LNP** query messages. This data is not required if this global title translation is performed in a preceding **STP**. The results of the global title translation is an alias point code (or true point code of the **EAGLE LNP**) and **SSN** of the **LNP** query function. The alias point code represents the **LNP** query function. Using the alias point code instead of true point code allows using same global title translation record in both mated **STPs**. This global title translation data can be configured from **SEAS** or **EAGLE LNP** terminals.
- **LNP** information for each 10 digit ported telephone number. This data is received from the **LSMS**.
 - Directory number (**DN**) or range of directory numbers
 - Location routing number (**LRN**)
 - Current facilities based service provider **ID**
 - Service 1 global title translation data through Service 6 global title translation data (**DPC/SSN**, routing indicator, etc.)
 - Billing Service Provider **ID**

- If the global title translation is a final global title translation, then the mated application and related data (loadshare mode, concerned point code list, etc.) corresponding to the global title translation data.
- Parameters required to customize **LNP** query and response processing. These are configured on each **EAGLE LNP**.
 - **AMAslpID** value
 - Indicator to include or exclude **AMAslpID** parameter in the **AIN** response
 - Billing indicators (call type and feature **ID**) for the **IN** connection control response
 - 3 or 4 digit **CIC** for **IN** connection-control response

Parameters for treatment of outgoing global title translation messages. The new translation type and global title address indicator can be configured for each **DPC**, as long as the **DPC** is used in an existing non-final global title translation. The global title address indicator shows the outgoing global title address treatment, either the telephone number or **LRN**.

4.33 LNP—Element Manager System (EMS) (Release 22.0)

The **EMS** is an interface between the **EAGLE LNP** and the **LSMS** and converts the **LSMS** protocol (**CMIP**) to an asynchronous serial format. Two terminal disk module (**TDM**) ports (**RS-232**) running at 19,200 bps connect the **EMS** to the **EAGLE**. The **EMS** is connected to the **LSMS** using the Q.3 interface. The **EMS** is mounted in the **OAPF** frame.

The **EMS** performs these functions.

- Receiving **LNP** data and requests from the **LSMS** and converting the **LNP** data to **EAGLE LNP** commands
- Connection management to the **LSMS**
- Support data audit function between **EAGLE LNP** and the **LSMS**

The data downloaded to the **EAGLE** through the **EMS** is stored in the fixed disks on the **TDMS**.

The **EMS** is a **TEXAS MICRO™** Intelligent Processor Unit Telecommunications Server, model 9605 (Sparc 05, 85 **MHz** processor) and contains:

- 32 megabytes of **RAM**
- a 1.02 gigabyte hard drive using a **SCSI** interface
- a 1.44 megabyte floppy disk drive, a high-speed serial interface (**HSI**) **SBUS** card (with 4 synchronous ports)
- **RS-232C**-extender **SBUS** communications board (with 4 asynchronous ports).

The **EMS** is powered from the **OAP** frame's fuse and alarm panel with -48 **VDC**.

The **EMS** uses this software to allow the **EAGLE** to communicate with the **LSMS**.

- **SUN™** Solaris version 2.4 operating system
- SunLink Solaris version 9 for X.25
- The **EMS** application software.

The **EMS** is deployed in pairs at each **EAGLE LNP** for redundancy.

4.34 LNP—Enhanced Global Title Translation Routing Services (Release 22.0)

This capability locates the **LNP** database using 10 digit global title translation. To implement this capability, these features are required.

- Ported **NPANXX** detection - the **EAGLE LNP** maintains a list of all ported **NPANXXs** for each translation type that the node must perform 10 digit global title translation for. The first pass search shows if the number belongs to a ported **NPANXX**.

If the number does not belong to a ported **NPANXX**, normal global title translation is performed on the number.

If the number belongs to a ported **NPANXX**, two options are available for performing **LNP** global title translation.

- The **EAGLE LNP** is not responsible for performing 10 digit **LNP** global title translation. The **EAGLE LNP** performs normal global title translation which results in routing the **MSU** to an external **LNP** database (for example, an **LNP SCP**) or another **STP**.
- The **EAGLE LNP** is responsible for performing 10 digit **LNP** global title translation. This routes the **MSU** to an internal **LNP** subsystem for performing 10 digit **LNP** global title translation.
- Message Relay - This function is required to perform 10 digit **LNP** global title translation while maintaining backward compatibility with existing non-**LNP OSSs**. Currently, **OSSs** (and some switches) use 6 digit global title translation for certain services. To minimize the impact of **LNP** on these systems, they will continue to route using 6 digit global title translation. If the called party address does not include 10 digits, the 10 digits are extracted from the **TCAP** portion of the message and are used as a global title address (**GTA**).
- Prevention of **SCCP** looping - The complexity of **LNP** data administration across multiple carrier networks increases the chances of data inconsistencies and may result in **SCCP** circular looping. The global title translation feature has been enhanced to modify the translation type (**TT**) and global title address (**GTA**) as result of translation. The **GTA** is replaced by the location routing number. This function is optional and can be configured by the user.
- **SMS** interface - the **SMS** interface is required for loading **LNP** global title translation data from an **SMS** system.
- 10 digit final **LNP** global title translation - The **EAGLE LNP** requires that final global title translation is performed on 10 digits. When the **STP** performs 10 digit final global title translation, it will be capable of supporting routing and management of mated databases. All existing functions (load sharing between databases, primary/backup relationship between databases, remote subsystem management, translation type mapping, translation aliasing, etc.) are performed with the 10 digit final **LNP** global title translation.
- 6 digit default **LNP** global title translation - If the 10 digit global title translation does not find a match (for example, when a number is not ported but belongs to a ported **NPANXX**), the **EAGLE LNP** performs a 6 digit default global title translation.

4.35 LNP—Inhibit Subsystem Command (Release 22.0)

The `inh-ss` command is used to place a mated application subsystem out of service. This command uses two parameters, `ssn` and `force`. The `ssn` parameter specifies the subsystem number of the mated application subsystem to be taken out of service. If the `inh-ss` command is entered with the `force` parameter set to `yes`, the mated application subsystem is forced out of service. When the subsystem has been successfully taken out of service, the primary maintenance state of the specified mated application subsystem is set to **OOS-MT-DSBLD** (out of service maintenance disabled).

4.36 LNP—Impact of LNP on Other Features (Release 22.0)

Gateway Screening

Gateway screening has been modified to help prevent the looping of **SCCP** messages. When **LNP** global title translation is performed at **SCCP** level, **SCCP Called Party Address** screening is performed after the 6 digit default global title translation, if required, or after 10 digit **LNP** global title translation.

Translation Type Mapping

Translation type mapping is used on internetwork linksets to prevent the looping of **SCCP** messages between networks. For example, an originating network maps the translation type **x** to the new value **y** before transmitting it to the destination network. The new translation type value **y** is used in the destination network for translating and routing the **MSU** to a node inside the destination network. The **MSU** stays inside the destination network and message looping is prevented.

STPLAN

Gateway screening is used for **STPLAN** feature to selectively copy **MSUs**. This has the same impact as gateway screening.

Database Transport Access (DTA)

LNP has no impact on the **DTA** feature because **MSUs** are only redirected by the **DTA** feature before any global title translation takes place.

Other Features

Because **LNP** applies only to **ANSI SS7** networks, the **LNP** feature has no impact on these features.

- **ITU/ANSI** Interworking
- **X25/SS7** Interworking

4.37 LNP—Location Routing Number Commands (Release 22.0)

Refer to the *Commands Manual* for current usage information.

```
ent-lnp-lrn
```

The `ent-lnp-lrn` command is used to add an **LNP** location routing number (`lrn`) and its corresponding overriding message relay global title translations (`mrgt`) to the database.

```
dlt-lnp-lrn
```

The `dlt-lnp-lrn` command is used to remove a location routing number or its corresponding overriding message relay global title translations from the database.

```
chg-lnp-lrn
```

The `chg-lnp-lrn` command is used to change the attributes of an existing **LRN** and its corresponding overriding message relay global title translations in the database.

```
rtrv-lnp-lrn
```

The `rtrv-lnp-lrn` command displays all the **LRNs** and their associated final overriding message relay global title translations in the database.

4.38 LNP—Mapping LNP Translation Type Commands (Release 22.0)

Refer to the *Commands Manual* for current usage information.

```
chg-lnp-ttmap
```

The `chg-lnp-ttmap` command is used to change globally administered **NGT** and **RGTA** indications for each point code and translation type combinations for a group of existing telephone numbers in the database.

```
rtrv-lnp-ttmap
```

The `rtrv-lnp-ttmap` command displays all globally administered **NGT** and **RGTA** indications for each point code and translation type combinations for a group of existing telephone numbers in the database.

4.39 LNP—Measurements (Release 22.0)

Overview

LNP measurements are obtained using the `rept-meas` command and specifying the report types **MTCH** (`:type=mtch`, an hourly maintenance report) or **MTCD** (`:type=mtcd`, a daily maintenance report) and the entity type **LNP** (`:enttype=lnp`). When a report of **LNP** measurements is requested with the `rept-meas` command, four comma delimited text files containing the **LNP** measurement information are created in the file transfer area on the active fixed disk. For a daily maintenance report, these files are created.

- **MDAY_LNP.CSV** - Daily **LNP** System Wide Measurements
- **MDAY_SSP.CSV** - Daily **LNP** Measurements per **SSP**
- **MDAY_LRN.CSV** - Daily **LNP** Measurements per **LRN**
- **MDAY_NPA.CSV** - Daily **LNP** Measurements per **NPA**

For an hourly maintenance report, these files are created.

- M60_LNP.CSV - Hourly LNP System Wide Measurements
- M60_SSP.CSV - Hourly LNP Measurements per SSP
- M60_LRN.CSV - Hourly LNP Measurements per LRN
- M60_NPA.CSV - Hourly LNP Measurements per NPA

LNP—System Wide Measurements

Table 4-13 MTCD - LNP and MTCH-LNP System Wide Measurement Report

Event Name	Description	Unit
LNPQRCV	The number of total queries received by LNPQS.	peg count
LNPQDSC	The number of invalid queries that are discarded as no reply can be generated.	peg count
LNPQTCPE	The number of error replies with TCAP error code.	peg count
LNPSREP	The number of successful replies.	peg count
LNPQUNPA	The number of correct queries received for non-ported DN when NPANXX is not provisioned.	peg count

This is an example of the text file created when a system wide LNP measurement report is requested.

```
"rlghncxa03w 97-06-30 15:51:37 EST Rel 22.0.0 "<cr><lf>
"TYPE OF REPORT: DAILY MAINTENANCE MEASUREMENTS ON LNP SYSTEM"<cr><lf>
"REPORT PERIOD: LAST"<cr><lf>
"REPORT INTERVAL: 97-06-29, 00:00:00 THROUGH 23:59:59 "<cr><lf>
<cr><lf>
"LNPQRCV", "LNPQDSC", "LNPQTCPE", "LNPSREP", "LNPQUNPA"<cr><lf>
4294967295, 4294967295, 4294967295, 4294967295, 4294967295<cr><lf>
```

SSP Measurements

Table 4-14 MTCD - LNP and MTCH-LNP SSP Measurement Report

Event Name	Description	Unit
SSPQRCV	The number of correct queries received per originating SSP.	peg count

This is an example of the text file created when an SSP LNP measurement report is requested.

```
"rlghncxa03w 97-06-30 15:51:37 EST Rel 22.0.0 "<cr><lf>
"TYPE OF REPORT: DAILY MAINTENANCE MEASUREMENTS ON LNP SSP"<cr><lf>
"REPORT PERIOD: LAST"<cr><lf>
"REPORT INTERVAL: 97-06-29, 00:00:00 THROUGH 23:59:59 "<cr><lf>
<cr><lf>
"SSP", "SSPQRCV"<cr><lf>
"002-002-100", 123456789<cr><lf>
```

```
"004-052-033",23456789<cr><lf>
"001-023-073",456789<cr><lf>
"240-098-019",345<cr><lf>
"123-043-099",99999<cr><lf>
"123-048-059",4294967295<cr><lf>
```

LNP—LRN Measurements

Table 4-15 MTCD - LNP and MTCH-LNP LRN Measurement Report

Event Name	Description	Unit
LRNQRCV	The number of correct queries received per LRN .	peg count

This is an example of the text file created when an **SSP LNP** measurement report is requested.

```
"rlghncxa03w 97-06-30 15:51:37 EST Rel 22.0.0 "<cr><lf>
"TYPE OF REPORT: DAILY MAINTENANCE MEASUREMENTS ON LNP LRN"<cr><lf>
"REPORT PERIOD: LAST"<cr><lf>
"REPORT INTERVAL: 97-06-29, 00:00:00 THROUGH 23:59:59 "<cr><lf>
<cr><lf>
"LRN", "LRNQRCV"<cr><lf>
9194560000,123456789<cr><lf>
4087550001,23456789<cr><lf>
5155550000,456789<cr><lf>
3022330001,345<cr><lf>
7032110002,99999<cr><lf>
8123048059,4294967295<cr><lf>
```

NPANXX Measurements

Table 4-16 MTCD - LNP and MTCH-LNP NPANXX Measurement Report

Event Name	Description	Unit
NPAQRCV	The number of correct queries received per NPANXX for non-ported DN .	peg count

This is an example of the text file created when an **NPANXX LNP** measurement report is requested.

```
"rlghncxa03w 97-06-30 15:51:37 EST Rel 22.0.0 "<cr><lf>
"TYPE OF REPORT: DAILY MAINTENANCE MEASUREMENTS ON LNP NPXNXX"<cr><lf>
"REPORT PERIOD: LAST"<cr><lf>
"REPORT INTERVAL: 97-06-29, 00:00:00 THROUGH 23:59:59 "<cr><lf>
<cr><lf>
"NPANXX", "NPAQRCV"<cr><lf>
919456,123456789<cr><lf>
408755,23456789<cr><lf>
515555,456789<cr><lf>
```

```
302233,345<cr><lf>  
703211,99999<cr><lf>  
812304,4294967295<cr><lf>
```

Once the **LNP** measurement files have been created in the file transfer area on the active fixed disk, these files can be transferred to another computer using the `act-file-trns` command for further processing. To make the file transfer, the computer that the files are transferred to must have these items.

- a **VT320** or **KSR** connection to the **EAGLE LNP**
- a communication program that emulates **VT** terminals and supports Kermit file transfer, for example, ProComm[®] for Windows
- a spreadsheet software program that interprets comma separated value text files, for example, Microsoft Excel[®]

Once the measurement text files have been created, they must be transferred to another computer. When the files have been transferred, they must be removed from the file transfer area with the `dlt-fta` command. If these files are not removed, no other **LNP** measurement reports of that report type can be created.

4.40 LNP—Message Relay (Release 22.0)

Message Relay (**MR**) contains these enhancements to existing global title translation functions.

- Extraction of 10 digit dialed number from the **TCAP** portion of the message: If the **MSU** contains a 6 digit called party address, the 10 digit dialed number is extracted from the **TCAP** portion of the **MSU**.
- Increased number of translations: For each 10 digit dialed number, up to 6 translations are available. The previous limit was 270,000 total translations. The number of dialed numbers that can be entered depends on the hardware, but the minimum hardware configuration supports 500,000 dialed numbers, so 3 million translations can be entered on the minimum hardware configuration. The maximum hardware configuration supports 2 million dialed numbers, so 12 million message relay translations can be entered on the maximum hardware configuration.
- Replacing the global title address: The global title address in the called party address can be replaced with the **LRN** associated with the ported dialed number.

Message Relay is performed in three stages:

1. The message arrives at the **EAGLE LNP** `route-on-gt`. The **EAGLE LNP** performs 6 digit (**NPANXX**) translation. The result of this translation indicates if message relay is required. If it is required, the result of this translation also gives the default data that may be used in stage 3.
2. If the results of stage 1 indicates message relay is required, the **EAGLE LNP** performs 10 digit message relay. If the 10 digit number is found, the translation data for the 10 digit number is used to route the message.
3. If the 10 digits are not found, the dialed number is not ported, and the default data from stage 1 is used to route the message.

4.41 LNP—MSU Trap and Trace Command (Release 22.0)

Refer to the *Commands Manual* for current usage information.

The `ent-trace` command is a debug command used to trace **MSUs** sent to **SCCP** cards.

4.42 LNP—MTP and SCCP Management to Support LNP (Release 22.0)

When the **LNP** subsystem goes offline, the **EAGLE** sends **SSPs** that cause messages with the routing indicator set to **SSN** to be diverted to the mate subsystem. But these will not cause messages with the routing indicator set to **GT** to be diverted. In order to make other nodes divert the messages with the routing indicator set to **GT** to the mate, the **EAGLE** sends response method **TFPs** for these messages that require either message relay or **LNP** query.

There are two reasons the **EAGLE** generates a response method **TFP**.

While the **LNP** subsystem is offline, a message arrives with the routing indicator set to **GT** for one of **EAGLE**'s capability point codes. The result of the global title translation is the **EAGLE**'s **LNP** subsystem or that message relay is required on **EAGLE**.

In both of these cases, the **EAGLE** generates a **TFP** concerning the capability point code and sends the **TFP** to the **OPC** in the message. This **TFP** should cause the **OPC** to divert traffic to the mate. If a message arrives with the routing indicator set to **GT** for **EAGLE**'s true point code, **EAGLE** does not generate a **TFP**. Nodes that send traffic to **EAGLE** with the routing indicator set to **GT** should use one of **EAGLE**'s capability point codes, not **EAGLE**'s true point code.

If the **EAGLE** receives an **RSP** (**Route Set Test Message - Prohibited**) for a capability point code that is used for **LNP**, and the **LNP** subsystem is offline, the **EAGLE** does not reply. If the **EAGLE** receives an **RSR** (**Route Set Test Message - Restricted**) for a capability point code for **LNP**, and the **LNP** subsystem is offline, the **EAGLE** replies with a **TFP** concerning the capability point code. When **LNP** subsystem is online, the **RSRT** replies to both **RSRs** and **RSPs** for a capability point code that is used for **LNP** with a **TFA**.

4.43 LNP—New LNP Input and Output Groups (Release 22.0)

The **LNP** commands described in the New Commands section are assigned to three new command classes: **LNP Basic**, **LNP Database Administration**, and **LNP Subscription**. To allow users to execute these commands, three new parameters have been added to the `ent-user`, `chg-user`, and `chg-secu-trm` commands: `lnpbas`, `lnpdb`, and `lnpsub`. To show the values assigned to these parameters, the `lnpbas`, `lnpdb`, and `lnpsub` fields have been added to the `rtrv-secu-user`, `rtrv-user`, and `rtrv-secu-trm` command outputs.

Two new unsolicited output message groups have been added to support the **LNP** feature: **LNP Database Administration** and **LNP Subscription**. To allow these types of messages to be output on a specific terminal, the `lnpdb` and `lnpsub` parameters have been added to the `chg-trm` command. To show the values assigned to these parameter, the **LNPDB** and **LNPSUB** fields have been added to the `rtrv-trm` command output.

4.44 LNP—New Unsolicited Alarm Messages (UAMs) (Release 22.0)

LNP Degraded Mode Alarm

This critical alarm is displayed when the system automatically puts itself in a degraded mode because of invalid **OAM** hardware configuration for the **LNP** feature.

UAMs

```
*C 0012.0419 *C SYSTEM           Entering LNP Degraded Mode
```

When the reason the system has entered degraded mode is resolved, this message is displayed showing that system has returned to normal operation.

```
0012.0420     SYSTEM           Exiting LNP Degraded Mode
```

LNP—Auto Inhibit/Uninhibit Alarms

This minor alarm is displayed when an **SCCP** card does not have the hardware configuration required for the **LNP** application. Loading of the **SCCP** card is automatically inhibited.

```
* 0012.0421 * CARD 1108 SCCP           CARD REPAIR: Incorrect HW
configuration
```

This minor alarm is displayed when an **SCCP** card hardware configuration does not have enough memory for the **LNP** data. Loading of the **SCCP** card is automatically inhibited.

```
* 0012.0422 * CARD 1108 SCCP           CARD REPAIR: Insufficient
memory for LNP
```

When the `alw-card` command is executed, loading of the **SCCP** card is attempted. This message is displayed indicating that card loading is no longer inhibited.

```
0012.0423     CARD 1108 SCCP           CARD REPAIR: Card reload
attempted
```

LNP Subsystem Alarms

This critical alarm is displayed when the **LNP** subsystem is unavailable.

UAMs

```
*C 0012.0424 *C LNP SYSTEM          LNP Subsystem is not available
```

This minor alarm is displayed when the **LNP** subsystem is available, but the **LNP** Status of all of the **SCCP** cards is not **ACTIVE**.

```
* 0013.0425 * LNP SYSTEM          LNP normal, card(s) abnormal
```

This message is displayed when the **LNP** subsystem becomes available.

```
0014.0426 LNP SYSTEM          LNP subsystem is available
```

4.45 LNP—New Unsolicited Information Messages (UIMs) (Release 22.0)

LNP—Subsystem State Change Failures

When the `inh-ss` command is entered and the subsystem is not inhibited, but an inhibit request is already outstanding, this message is displayed.

UAMs

```
RLGHNCXA03W 97-06-30 16:28:08 EST Rel 22.0.0  
0002.1164 SYSTEM INFO Inh LNP SS request already  
outstanding  
Report Date: 94-03-30 Time: 16:27:19
```

The failure of a coordinated state change of the **LNP** subsystem resulting from the `inh-ss` command will be reported with this message.

```
RLGHNCXA03W 97-06-30 16:28:08 EST Rel 22.0.0  
0002.1165 SYSTEM INFO Failure Inhibiting LNP SS  
Report Date: 94-03-30 Time: 16:27:19
```

LNP—ACG Overload Level Change

When the overall **ACG** overload level of the system has changed, **UIM 1166** is displayed.

UAM

```
RLGHNCXA03W 97-06-30 16:28:08 EST Rel 22.0.0  
0003.1166 SYSTEM INFO ACG Node Overload Level Change
```

OLD ACG LEVEL= 4 NEW ACG LEVEL= 5
Report Date: 94-03-30 Time: 16:27:19

4.46 LNP—NPANXX Commands (Release 22.0)

Refer to the *Commands Manual* for current usage information.

`ent-lnp-npanxx`

The `ent-lnp-npanxx` command is used to add an **LNP NPANXX** (area code and office prefix) and its associated default global title translations to the database.

`pdlt-lnp-npanxx`

The `dlt-lnp-npanxx` command is used to remove an **LNP NPANXX** or its associated default global title translations from the database.

`chg-lnp-npanxx`

The `chg-lnp-npanxx` command is used to change the attributes of an existing **LNP NPANXX** and its associated default global title translations in the database.

4.47 LNP—Query Routed as Final Global Title Translation (Release 22.0)

Description

This is a case where the final global title translation is performed by a different **STP** before routing the **LNP** query to the **EAGLE LNP**. The first **STP** performs the 6 digit final global title translation and routes the message using **EAGLE LNP**'s true point code and subsystem number of **LNP** query application. The **EAGLE LNP** processes **LNP** query and sends an **LNP** response. The following figure illustrates this action.

Figure 4-15 LNP Query Routed as Final Global Title Translation

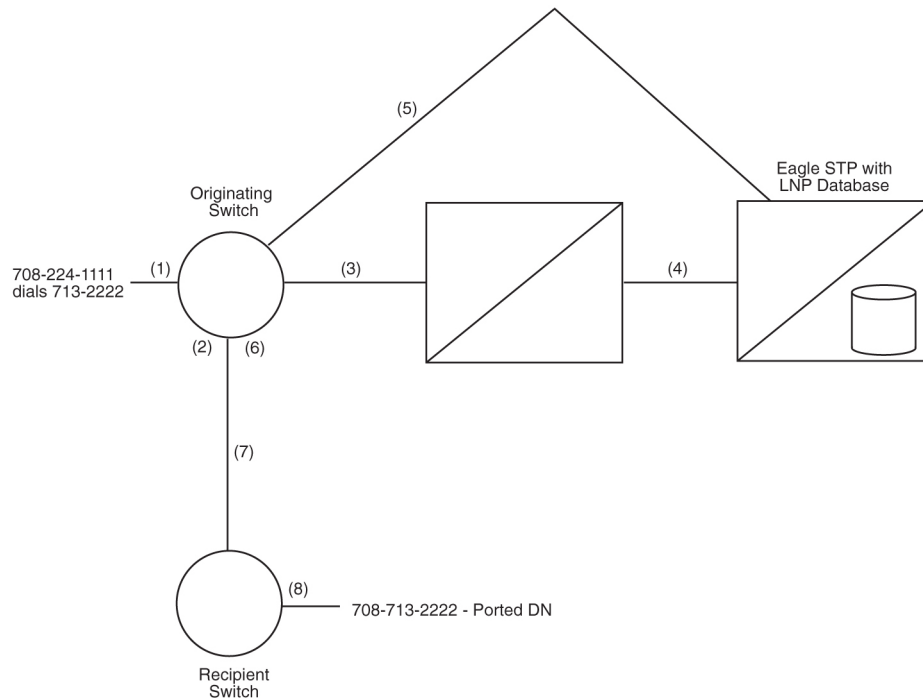

1. Line A (708-224-1111) dials Line B (708-713-2222).
2. The originating switch performs digit analysis on the dialed digits to determine how to route the call. The switch determines that B is in a portable **NPANXX** (708-713) and the line does not reside on the switch.
3. The switch sends an **AIN** (Info_Analyzed) or **IN** (InstructionStart) query based on the dialed digits to the capability point code of the first **STP**.
4. The **STP** performs final global title translation using 6 digits, determines that the query should be routed to **EAGLE LNP**. The query is routed to **LNP** application at **EAGLE LNP** using its true point code and subsystem number identifying **LNP** query application.
5. The **LNP** application at **EAGLE LNP** finds the telephone number in its **LNP** database and sends an **AIN** (Analyze_Route) or **IN** (ControlConnect) response containing the **LRN** of the recipient switch.
6. The originating switch receives the **LNP** response and analyzes the data. The **LRN** is translated in the **LNP** routing tables and an **ISUP** route out of the switch is determined. The **LRN** is stored in the called party number parameter and the dialed digits are stored in the generic address parameter of the **ISUP IAM** message. The **FCI** translated called number indicator is set to indicate a query has been done (set to "translated number").
7. The call is routed to the recipient switch based on the **LRN**.
8. The recipient switch receives and processes the contents of the **IAM** message. The switch determines that an **LRN** is received and that it is the switch's **LRN**, and the switch replaces the called party number parameter's contents with the dialed digits stored in the generic address parameter. The switch does digit analysis on the dialed digits and finds the subscriber on the switch. The recipient switch completes the call to the subscriber.

Global Title Translation Examples

CLASS TCAP Queries for Portable NPANXX to Another Network

Figure 4-16 Internetwork Class Query

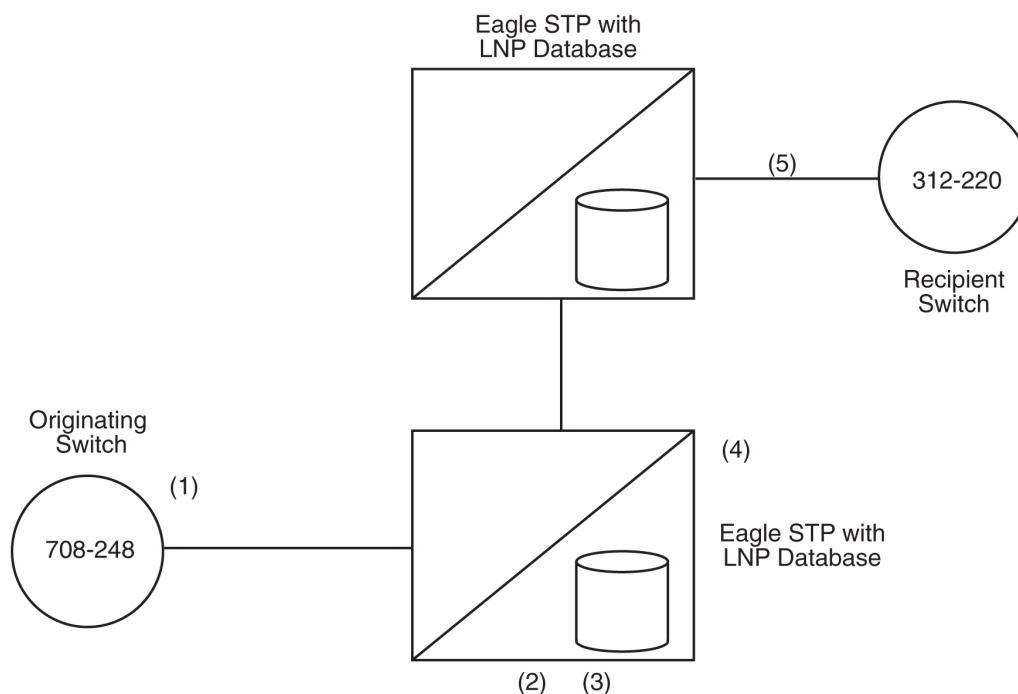

1. The originating switch (708-248) needs to launch a **CLASS** query for 312-727-1111. The switch formulates the query using the alias point code of the **EAGLESTP** as the destination, and codes the **SCCP** global title address as the queried number (312-727-1111). The translation type is coded as appropriate for a **CLASS** query.
2. The **EAGLESTP** receives the query and looks up the global title address of 312-727-1111 in the six digit global title translation table identified by the translation type. Since 312-727 has been designated as a portable **NPANXX**, the six digit global title translation indicates that message requires 10 digit global title translation on **EAGLE**.
3. The **EAGLE** message relay function checks to see if there is a ten digit translation for the number in the global title address. If there is, the translation information is used to forward the query to the gateway **STP** of the switch currently serving that telephone number. If no 10 digit translation is found, then the telephone number is still associated with the donor exchange, and a default six digit translation for the **NPANXX** value would be performed before forwarding the query.
4. The **STP** performs **MTP** routing for the message.
5. The gateway **EAGLESTP** performs ten digit final global title translation and routes the **CLASS** query to the recipient switch. Remote subsystem management is performed. The recipient switch processes it as appropriate. The destination **SSP** can route the response message directly to the originating **SSP**, since the point

code and **SSN** for the originating **SSP** would have been carried unchanged in the calling party address of the **SCCP**.

Internetwork LIDB Query with 6 Digits Included in the Global Title Address

Figure 4-17 Internetwork LIDB Query with 6-Digit GTA

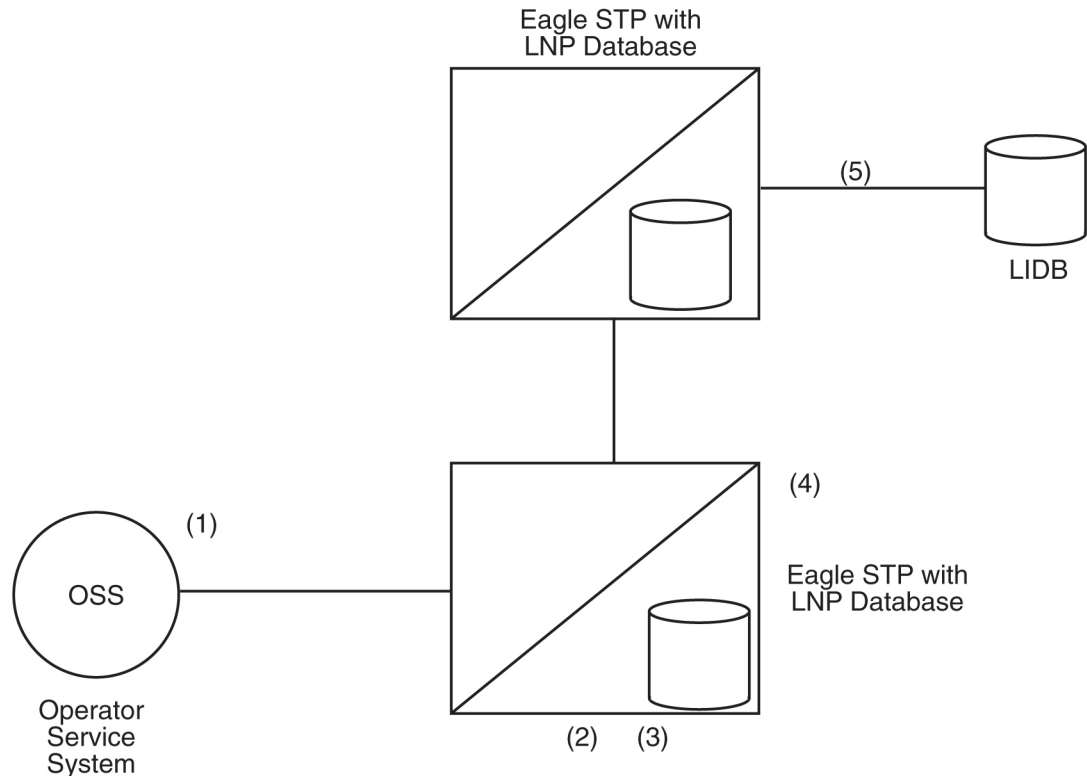

1. The operator service system launches a **LIDB** query for 312-727-1111. The switch formulates the query using the alias point code of the **STP** as the destination, and codes the **SCCP** global title address with the **NPANXX** of the queried number (312-727). The translation type is for a **LIDB** query.
2. The **STP** receives the query and looks up the global title address of 312-727 in the six digit global title translation table identified by the translation type. Since 312-727 has been designated as a portable **NPANXX**, the **EAGLESTP** forwards the query to the local **LNP** global title translation function.
3. The **LNP** global title translation function recognizes that only 6 digits are present in the global title address. Based on the translation type, the type of query (**LIDB**) is determined, and the **LNP** global title translation function decodes the necessary portion of the **LIDBTCAP** message to determine the ten digit telephone number for the **LIDB** query. Once the telephone number has been retrieved from the **TCAP** portion, the **LNP** global title translation function checks to see if there is a ten digit translation for the number. If there is a match on the full 10 digits of the telephone number, the translation information is used to route the message. (When no match is found for the 10 digit telephone number in the global title translation translations, the default data would be examined on a six digit basis to determine the translation information.) In this case, the ported number is served by another network, so the ten digit translation indicates a non-final global title translation to route to that network's gateway.

4. The **EAGLESTP** would perform **MTP** routing for the message. The message would be routed to the gateway **STP** in the next network.
5. The gateway **STP** receives the **LIDB** query and processes it as appropriate. The gateway **STP** may be able to perform a final global title translation based on the six digit global title address value, or may need to perform an **LNP** global title translation to route the message on ten digits. The gateway **STP** performs remote subsystem management.

4.48 LNP—Query Routed as Non-Final Global Title Translation (Release 22.0)

This is a case where the **LNP** query is routed as a non-final global title translation **MSU**. The **EAGLE STP** first performs the regular 6 digit global title translation. If the result of the global title translation is an internal **LNP** query application, the **LNP** query is processed and the response is sent to the originating switch. This example illustrates both normal 6 digit global title translation and **LNP** query processing are done on the same **STP**. The originating switch uses a separate capability point code (different from capability point code used for non-**LNP** global title translation) to route **LNP** global title translation traffic. The advantage of using a separate capability point code is that Level 3 network management can be performed independently for **LNP** global title translation traffic and non-**LNP** traffic, such as 800 global title translation traffic. For example, if the **LNP** application is manually taken out of service, the **STP** can divert the **LNP** traffic to the mate by sending a **TFR** concerning the **LNP** capability point code. The **EAGLE LNP** continues to process 800 global title translation traffic.

Figure 4-18 LNP Query Routed as a Non-Final Global Title Translation

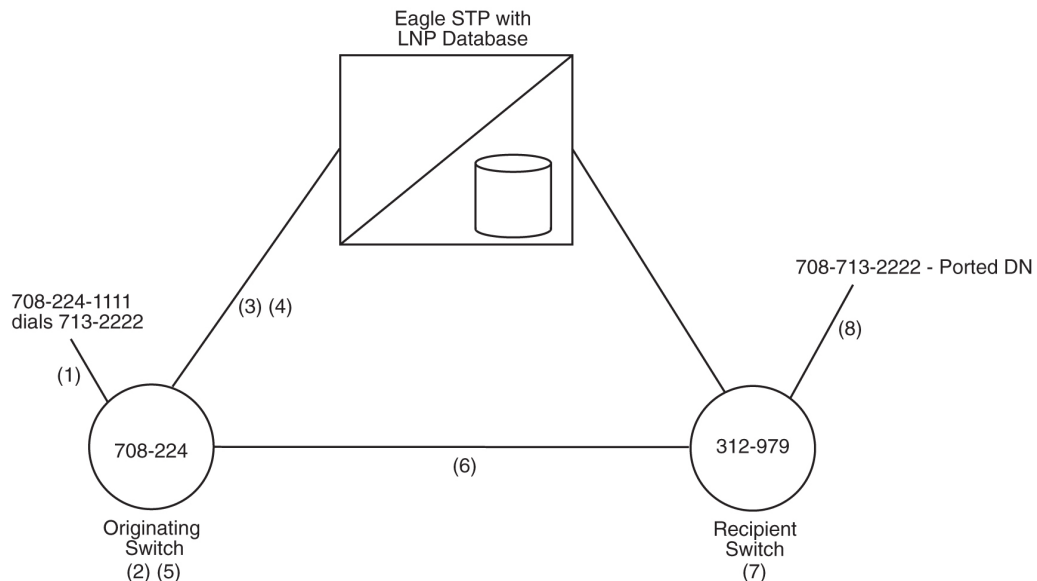

1. Line A (708-224-1111) dials Line B (708-713-2222).
2. The originating switch performs digit analysis on the dialed digits to determine how to route the call. The switch determines that B is in a portable **NPANXX** (708-713) and the line does not reside on the switch.

3. The switch sends an **AIN** (Info_Analyzed) or **IN** (InstructionStart) query based on the dialed digits to the capability point code of the **EAGLE STP** pair. Different capability point codes are used for **LNP** and non-**LNP** global title translation.
4. The **EAGLE STP** performs global title translation on the query and sends the query to a local **LNP** subsystem. The local **LNP** subsystem finds the telephone number in its **LNP** database and sends an **AIN** (Analyze_Route) or **IN** (ControlConnect) response containing the location routing number (**LRN**) (312 979) of the recipient switch.
5. The originating switch receives the **LNP** response and analyzes the data. The **LRN** is translated in the **LNP** routing tables and an **ISUP** route out of the switch is determined. The **LRN** is stored in the called party number parameter and the dialed digits are stored in the generic address parameter of the **ISUP IAM** message. The **FCI** translated called number indicator is set to indicate a query has been done (set to “translated number”).
6. The call is routed to the recipient switch based on the **LRN**.
7. The recipient switch receives and processes the contents of the **IAM** message. The switch determines that an **LRN** is received and that it is the switch's **LRN**, and the switch replaces the called party number parameter's contents with the dialed digits stored in the generic address parameter. The switch does digit analysis on the dialed digits and finds the subscriber on the switch.
8. The recipient switch completes the call to the subscriber.

4.49 LNP—Report LNP Status Command (Release 22.0)

The `rept-stat-lnp` command displays the current status of **LNP**. This command uses the two parameters, `loc` and `card`.

The `loc` parameter is used to display a detailed status of **LNP** information for the **TSM** specified by the `card` location. This detailed report includes information for each of the global title translation (**GTT**), **LNP** message relay (**LNPMR**), **LNP** query service (**LNPQS**) and automatic call gapping (**ACG**) functions.

The `card` parameter has only one value, `sccp-all`. When `card=sccp-all` parameter is specified, a detailed status of **LNP** information for all **SCCP** cards is provided.

When the `rept-stat-lnp` command is entered with no parameters, a summary of the **LNP** status of all equipped **TSMs** is provided. This summary includes global title translation (**GTT**) and **LNP** function status for every **TSM** as well as **LNPQS** system information. The possible states of the global title translation status are **ACTIVE** and **SWDL** (software loading). The possible states of **LNP** Status are **ACTIVE**, **OFFLINE** and **SWDL**.

Refer to the *Commands Manual* for current information on this command.

4.50 LNP—Rerouting Messages for the Local Subsystem (Release 22.0)

If the local **LNP** subsystem is unavailable and the mated subsystem is available, **EAGLE** uses the routing indicator to determine whether to reroute the message.

If the routing indicator of the message is **SSN**, **EAGLE** does not reroute the message to the mate. In this case, **EAGLE** is acting as an end node, and end nodes do not reroute. If the return on error option is set, **EAGLE** will generate a **UDTS**, otherwise it discards the message

If the routing indicator of the message is **GT**, **EAGLE** reroutes the message to the mated subsystem.

4.51 LNP—Retrieve LNP Database Time Stamp Command (Release 22.0)

The `rtrv-lnp-dbts` command displays the **LNP** database time stamp corresponding to the latest **LNP Database** update applied by the **LSMS**.

The time stamp displayed by this command is updated when an **LNP** database is downloaded from the **LSMS** with the `chg-db:action=import` command or when a command updating a 10 digit telephone number subscription is received from the **LSMS**.

Refer to the *Commands Manual* for current information on this command.

4.52 LNP—SCCP Management on the LIMs (Release 22.0)

SCCP Management (SCMG) on the **LIM** is used when the **LIM** does not have an **SCCP** card assigned to it. The following figure shows the message flow for **SCMG**. If an **SCCP** message arrives destined for **EAGLE**, the cluster manager (**CM**) attempts to send the message to an **SCCP** card. If the **LIM** is not assigned to an **SCCP** card, the cluster manager sends the message to **SCMG** on the **LIM**.

Figure 4-19 SCMG on the LIM

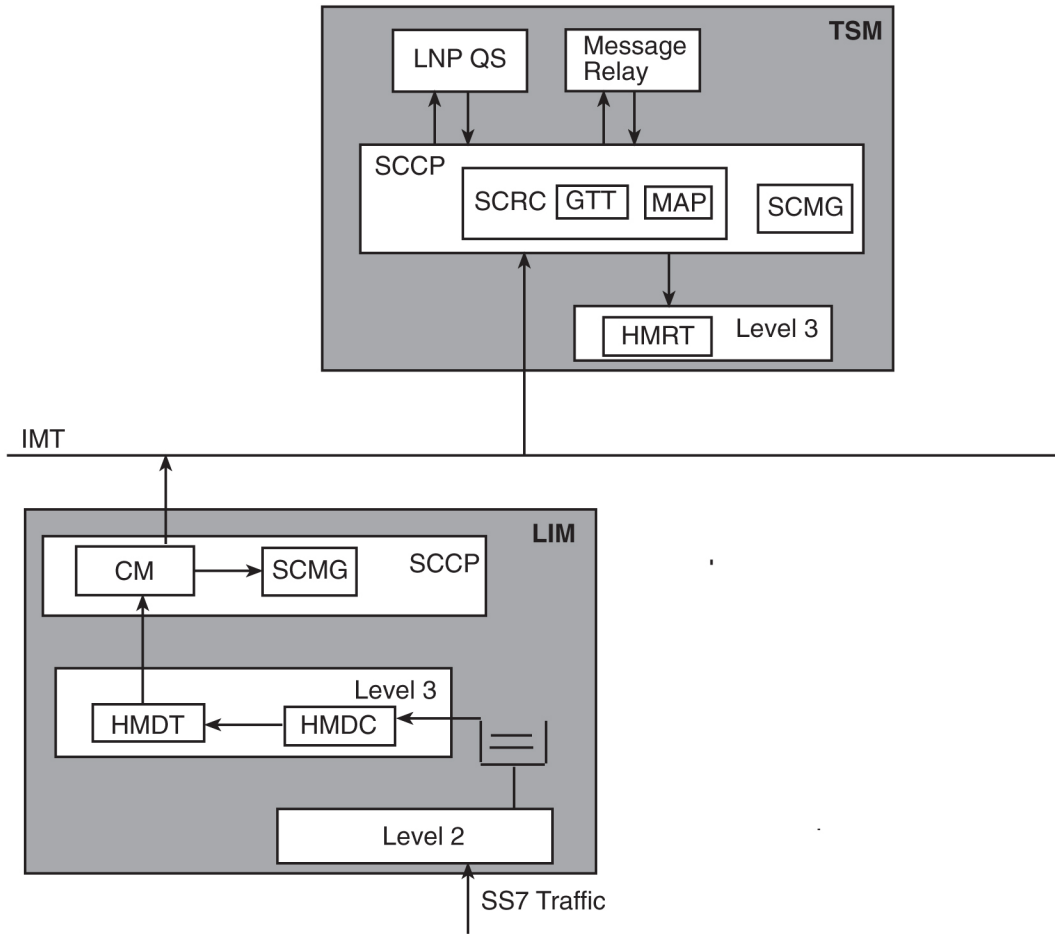

SCMG on the **LIM** first determines if all **SCCP** cards have failed. It performs the following functions when all **SCCP** cards are unavailable:

1. Generate response method **SSPs** if the routing indicator in the message is **SSN** for a local subsystem, other than **SCMG**.
2. Notify **MTP** to generate response method **TFPs** if the routing indicator of the message is **GT** and is destined for an **EAGLE** capability point code that is used for **LNP**.
3. Generate **UDTS** messages if the incoming message is a **UDT** with the return on error option.

If some **SCCP** cards are available, **SCMG** does not send **SSPs** or **TFPs**. In this case, the **SCCP** cards are available, but are overloaded. This is a partial failure: some **LIMs** have been denied service, but other **LIMs** have **SCCP** service. **SCMG** on the **LIM** still generates **UDTS** messages if the incoming message is a **UDT** with the return on error option.

 **Note:**

If the **UDT** message has a calling party address whose routing indicator is set to **GT**, the **LIM** does not generate a **UDTS**, because the **LIM** cannot perform global title translation.

The following table shows what actions the **EAGLE** takes when **SCCP** cards are unavailable and a message arrives requiring **LNP**.

Table 4-17 Receiving Messages when SCCP is Unavailable

Routing Indicator in Incoming Message	DPC	Full or Partial Failure	LNP Status	Message Handling	Network Management
GT	Capability Point Code	Full	--	Generate UDTS	Send TFP Concerning CPC
GT	True Point Code	Full	--	Generate UDS	Send UPU
SSN	Capability Point Code	Full	--	Generate UDS	None
SSN	True Point Code	Full	--	Generate UDS	Send SSP Concerning True Point Code
GT	LNP Capability Point Code	Partial	Online	Generate UDS	None
GT	True Point Code	Partial	Online	Generate UDS	None
SSN	LNP Capability Point Code	Partial	Online	Generate UDS	None
SSN	True Point Code	Partial	Online	Generate UDS	None
GT	LNP Capability Point Code	Partial	Offline	Generate UDS	Send TFP Concerning CPC
GT	True Point Code	Partial	Offline	Generate UDS	None
SSN	LNP Capability Point Code	Partial	Offline	Generate UDS	None
SSN	True Point Code	Partial	Offline	Generate UDS	Send SSP Concerning True Point Code
GT	Non LNP Capability Point Code	Partial	--	Generate UDS	None
SSN	Non LNP Capability Point Code	Partial	--	Generate UDS	None

4.53 LNP—Service Commands (Release 22.0)

Refer to the *Commands Manual* for current information on the following commands.

`ent-lnp-serv`

The `ent-lnp-serv` command is used to assign an **LNP** translation type to a unique **LNP** service.

Refer to the *Commands Manual* for current information on this command.

4.54 LNP—Service Provider Commands (Release 22.0)

Refer to the *Commands Manual* for current information on the following commands.

`ent-lnp-sp`

The `ent-lnp-sp` command is used to assign an **LNP** service provider to the database. The `ent-lnp sp` command uses only one parameter, `sp`—4 alphanumeric characters identifying the service provider.

`dlt-lnp-sp`

The `dlt-lnp-sp` command is used to remove an **LNP** service provider from the database. The `dlt-lnp-sp` command uses only one parameter, `sp`—4 alphanumeric characters identifying the service provider.

`rtrv-lnp-sp`

The `rtrv-lnp-sp` command displays the **LNP** service provider information in the database.

4.55 LNP—Split NPA Commands (Release 22.0)

Refer to the *Commands Manual* for current information on the following commands.

By splitting the **NPANXX**, the user can force 2 different **NPANXXs** to reference the same last 4 digits of a 10 digit ported telephone number in the database. When either **NPANXX** is updated, the 10 digit ported telephone numbers in each **NPANXX** with the same last 4 digits are updated. When the **NPANXX** is split, all existing **NPANXX** data for the **NPANXX** being split is copied to the new **NPANXX**.

`ent-split-npa`

The `ent-split-npa` command is used to add a split **NPANXX** to the database.

`dlt-split-npa`

The `dlt-split-npa` command is used to remove a split **NPANXX** from the database. The `dlt-split-npa` command uses only one parameter, `npa` - the split **NPANXX**, the value in either the **NPANXX** or **NEW NPANXX** fields of the `rtrv-split-npa` command output.

`rtrv-split-npa`

The `rtrv-split-npa` command displays all split **NPANXXs** in the database. Displaying the split **NPANXX** is done from the perspective of the old **NPANXX**, the **NPANXX** which contains default data.

4.56 LNP—Subsystem Application Commands (Release 22.0)

Refer to the *Commands Manual* for current information on the following commands.

`ent-ss-appl`

The `ent-ss-appl` command is used to reserve a subsystem number for the **LNP** application and place the **LNP** application either online or offline using the `ent-ss-appl` command.

`dlt-ss-appl`

The `dlt-ss-appl` command is used to remove a subsystem application from the database using the `dlt-ss-appl` command. The `dlt-ss-appl` command uses only one parameter, `:appl` = the subsystem application,. The **EAGLE LNP** contains only one subsystem application, the **LNP** subsystem application.

`chg-ss-appl`

The `chg-ss-appl` command is used to set an existing subsystem application either online or offline using the `chg-ss-appl` command.

`rtrv-ss-appl`

The `rtrv-ss-appl` command is used to display all of the applications from the database. The command displays the application type, subsystem number, and application status.

4.57 LNP—System Options Commands (Release 22.0)

Refer to the *Commands Manual* for current information on the following commands.

`chg-lnpopts`

The `chg-lnpopts` command is used to change the **LNP** specific options.

`rtrv-lnpopts`

The `rtrv-lnpopts` command displays the **LNP** specific system options in the database.

4.58 LOCREQ Query Response (Release 42.0)

The LOCREQ Query Response feature allows the EAGLE 5 ISS to respond to LOCREQ queries with a LOCREQ response message for both ported and non-ported subscribers.

The **LOCREQ** Query Response feature populates the RN of the ReturnResult message. Service Portability (**S-Port**) processing is used to control whether Generic Routing Number (**GRN**) or default RN digits are used for the **RN** in the ReturnResult message.

4.58.1 Feature Control Requirements

- FAK for Part Number 893-0385-01
- The A-Port (Part Number 893-0166-01) or IS41 GSM Migration (Part Number 893-0173-01) feature must be turned on before the LOCREQ Query Response feature can be enabled.
- The S-Port feature (Part Number 893-0379-01) must be turned on before S-Port processing can occur.
- The MNP service must be online before message processing can occur.

4.59 Login Failure Message (Release 21.0)

When a user attempts to log in to the **EAGLE** and enters either an invalid user **ID** or password, the **EAGLE** currently responds with the following message.

Error Messages

```
E2264 Cmd Rej: Password verification failed
```

Error message E2264 is the same message that is issued when the new and verify passwords entered during a password change do not match.

When this message is issued after a failed login attempt, it implies that only password was invalid, when an invalid user **ID** was entered with a correct password, or both the user **ID** and password were invalid.

Now, after a failed login attempt, the **EAGLE** responds with a new message,

```
E2757 Cmd Rej: Invalid userID/password combination.
```

When this message is received, the user should verify both user **ID** and password.

Error message E2264 is still issued when the new and verify passwords entered during a password change do not match.

4.60 Login Success or Failure Tracking (Release 21.0)

When a user has successfully logged on to the **EAGLE**, a message is displayed followed by 2 lines of login history information. The login history information contains the number of login failures that have occurred since the last time the user successfully logged in to the **EAGLE** and the date and time of the user's last successful login and the terminal that the user logged in to the **EAGLE** on. At each successful login, the login history messages are displayed to the user in the scroll area.

```
xxxx LOGIN failures since last successful LOGIN  
Last successful LOGIN was on port zz on yy-mm-dd @ hh:mm:ss
```

where:

xxxx—the number of unsuccessful login failures since the last successful login

zz—the number (1 - 16) of the port on which the last successful login occurred.

yy-mm-dd—the date of the last successful login

hh:mm:ss—the time of the last successful login

An unsuccessful login attempt is any use of the `login` command, while not already logged on, that does not result in the user getting logged on to the **EAGLE**. Some examples of an unsuccessful login in which the failure count maintained for the user **ID** is incremented are:

- user **ID** valid, password invalid
- user **ID** valid, password valid, user **ID** is already logged on at some other port.
- user **ID** valid, password valid, user **ID** has been suspended
- user **ID** valid, password valid, a password change is required and the new password is not valid
- user **ID** valid, password valid, the password is older than allowed by the `page` parameter of either the `ent-user`, `chg-user`, or `chg-secu-dflt` commands, the new password is not valid.
- user **ID** valid, password valid, the user **ID** has been inactive for a period of time that is greater than the value of the `uout` parameter of either the `ent-user`, `chg-user`, or `chg-secu-dflt` commands.

Login attempts that are rejected while a terminal port is temporarily locked out due to excessive login failures are not counted. While the terminal port is temporarily locked out, the **EAGLE** immediately rejects all login attempts regardless of the user **ID** specified on the `login` command and makes no attempt to verify that the specified user **ID**.

4.61 Logout on Communications Failures (Release 22.0)

Whenever communications is lost between the **EAGLE** and a terminal, the user logged on to that terminal will be automatically logged off. Some examples of communications loss are:

- terminal is powered off
- telephone connection between dial-up terminal and **EAGLE** is disrupted
- directly-connected terminal is unplugged from the backplane.

When communications between **EAGLE** and the terminal are re-established, the user must login on the terminal again to access the **EAGLE** on that terminal.

This does not apply to **SEAS** terminals. **SEAS** terminals are considered to be connected to the **EAGLE** by secure lines and the `login` command cannot be entered on that terminal.

When a user is logged off of a terminal because of a communications loss, the following message is displayed to all terminals that are able to receive unsolicited system administration messages in addition to the affected terminal.

```
User xxxxxxxx auto logged out (communications failure) on port yy.
```

Where:

xxxxxxx = the user **ID** that was logged off

yy = the affected terminal port (1 - 16)

If a user is logged off a terminal when the system is in the middle of processing a command that gathers passwords (for example, the `chg-pid`, `chg-user`, or `ent-user` commands), any prompt that is being displayed is removed and the character echo (which was disabled so that the password could be entered) is re-enabled. If the communications loss occurs while the system is in the middle of processing other types of commands (such as a database backup or restore), the user is logged off the terminal, but the command will continue to be executed until it has completed.

If the communications loss occurs while displaying the password prompt while the `login` command is being executed, the command is not interrupted since while the `login` command is in progress, the user is not yet logged in.

If the keyboard is locked when the communications loss occurs, the user is logged off and the keyboard is unlocked.

If a communication failure occurs while a file transfer is in progress, the user is logged off the terminal, but the file transfer continues. The communications failure may or may not affect the successful transfer of the file.

4.62 LRN Table Increase (Release 26.1)

This feature increases the size of the **LRN** table within **EAGLE** from 30000 **LRN** entries to 100000 **LRN** entries. It provides the user the ability to administer up to 100,000 **LRN** entries at the **EAGLE STP**. This number was selected because there are possibly 25,000 end offices, with two **LRNs** per office (2X maximum capacity).

The enlarged number of **LRN** entries applies to the **OAM** and **SCCPs GPLs**.

4.63 M2PA on IPLIMx (Release 29.1) (IP7 Release 7.1)

Description

The **M2PA** on **IPLIMx** feature provides support for the **IETF's SS7 MTP2-User Peer-to-Peer Adaptation Layer (M2PA)** protocol to the **IPLIMx**, prior to **RFC** status of the protocol.

The **SS7 MTP2-User Peer-to-Peer Adaptation Layer (M2PA)** protocol supports the transport of **SS7 Message Transfer Part (MTP)** Layer 3 signaling messages over **IP**, using the services of **SCTP**. This protocol would be used between the **IPLIMx** and an **IP** Signaling Point employing the **MTP** Level 3 protocol. **M2PA** is an **IETF-based** replacement for the **EAGLE STP IP** Transport feature.

This protocol is intended for use between:

- a Signaling Gateway (**SG**) and a Media Gateway Controller (**MGC**)
- an **SG** and an **IP** Signaling Point (**IPSP**)
- an **SG** and another **SG**

where Signaling Gateway (**SG**) is the **IPLIMx**-equipped **EAGLE STP** or **IP⁷** Secure Gateway.

The **M2PA** on **IPLIMx** feature enhances **IPLIMx** in the following ways:

- Adds the **M2PA** adapter type when provisioning an association for an **IPLIMx** card.
- Provides an **M2PA** implementation on **IPLIMx** that is compliant with v6 of the **M2PA** internet draft.
- A **M2PA** link provides for zero message loss on fail-over, while a **M3UA** link can lose messages.
- A **M2PA** link provides additional **MTP2** features beyond that provided by either **SAALTALI** or **M3UA** links.
- A **M2PA** association acts as both server and client. Both sides of an **M2PA** link may initiate the association. Two **EAGLEs** or Secure Gateways can be connected using **M2PA** links.

The following aspects of **IPLIMx** remain unchanged by this feature:

- **IPLIMx** on **SSEDCM** (870-2372-xx) continues to support both **SAALTALI** and **M3UA** links.
- **IPLIMx** on **SSEDCM** continues to provide a card capacity of 3000 **TPS**. Application-rated capacity on other cards is unaffected by this feature.
- **IPLIMx** on **SSEDCM** now supports a maximum of eight signaling links. This maximum applies to links of the **SAALTALI**, **M3UA**, and **M2PA** types.
- **IPLIMx** continues to support only **DPC-SLS** routing. Routing keys are not supported.
- Multiple **ITU-N** groups support is provided by **SAALTALI** and **M3UA** links. Support of multiple **ITU-N** groupcodes over **M2PA** links is provided only for links connecting two Tekelec **SGs**. Multiple **ITU-N** groupcode support is not provided by a **M2PA** link connecting a Tekelec **SG** to a non-Tekelec **IP** signaling point.
- **IPLIMx** does not support **ISUP** Normalization.

This feature allows for convergence of some signaling and data networks. Switched Circuit Network signaling nodes would have access to databases and other devices in the **IP** network domain that do not employ **SS7** signaling links.

Likewise, **IP** telephony applications would have access to **SS7** services over B, C, and D links. There also may be operational cost and performance advantages when traditional signaling links are replaced by **IP** network "connections."

Hardware Requirements

This feature requires the Single Slot **EDCM** (870-2372-01).

Limitations

The **M2PA** draft v6 protocol provides no facility for specifying network context, such as a group code or network appearance.

IPLIMx supports multiple **ITU-N** groupcodes over a **M2PA** link, when the link connects two Tekelec **SGs**, and each Tekelec **SG** has the **ITUDUPPC** feature bit enabled. **IPLIMx** does not support multiple **ITU-N** groupcodes over a **M2PA** link, when the link connects a non-Tekelec signaling point, or the Tekelec **SG ITUDUPPC** feature bit is disabled.

4.64 M2PA RFC Support (Release 34.3)

The **MTP** Level 2 Peer to Peer Adaptation Layer (**M2PA**) is a protocol used between the **SCTP** and the **MTP** Level 3 that enables **SS7** links to run over **IP**.

M2PA provides a mechanism to transport **SS7 MTP2** user signaling (e.g., **MTP3** messages) over **IP** using **SCTP**. **M2PA** enables seamless operation between **MTP2** user peers in the **SS7** and **IP** space.

The **M2PA RFC** Support feature adds functionality to support the **M2PA RFC** implementation while continuing to support earlier (Draft 6) implementations.

To aid the transition from Draft 6 to **RFC**, the following changes are implemented:

1. 20 new **M2PA** timer sets are created for **M2PA RFC** associations.
2. Existing associations are changed to have **ver=d6** during upgrade.
3. **M2PA** Draft 6 timer set values were not changed during upgrade (T16 changed from ms to s, hence table values are multiplied by 1000).
4. **M2PA** Draft 6 associations use the **d6** timers.
5. **M2PA RFC** adapters use the **rfc** timers.

Note:

It is not necessary to change the **m2patset** value on the association to retrieve the new timer values.

6. The **chg-m2pa-tset** command defaults to the **rfc** values.
7. To change the **M2PA** Draft 6 timers, a new **ver=d6** parameter is specified.

4.65 M3UA Protocol Enhancements (EAGLE Release 30.0/IP7 Secure Gateway Release 8.0)

Description

Customers for **M3UA** have requested the implementation of the enhancements to **RFC3332** to ease **Application Server** development, enhance robustness, and incorporate support for the **SG** abating congestion and maintaining congestion status of **SS7** destinations on behalf of **AS**'s.

Since the introduction of the **IETF** Sigtran protocols in **IP7** Secure Gateway Release 5.0, the **IETF** has created newer versions of these protocols. This feature updates the **IP7** Secure Gateway and **EAGLE IPLIMx** implementation of these protocols to the current revisions.

The following summarizes the **M3UA RFC** updates to this feature:

- Tekelec's **M3UA** implementation adds support for the optional **ASP ID** parameter.
- Congestion Control
 - The Secure Gateway prevents a **UA** (IETF User Adaptation Layers) association from remaining congested forever.
 - The Secure Gateway maintains congestion status of **SS7** destinations on behalf of the Applications Servers, as well as abates congestion.
- This feature complies with **RFC3332**, and supports additional protocol updates.
- This feature also supports several “custom” extensions to **RFC3332**, to satisfy customer requests.

Hardware Requirements

The **M3UA** for **IP7** 8.0 feature runs on existing hardware, i.e. the Single Slot Enhanced **DCM** (P/N 870-2372-01).

Limitations

1. Tekelec's implementation neither supports nor prevents hooking up **M3UA** to **M3UARFC** associations, and relies on the **M3UA** user to configure both ends correctly. A mismatch between versions can transition to the **ASP-UP** and **ASP-Active States**, although **DATA** Messages and others may fail with error messages returned. No adverse affects should occur either.
2. In Tekelec's implementation, since individual queues are not allocated to **ASs**, any initiation of the **AS** Recovery Timer $T(r)$ causes the **L3_L2** queue for the entire **IPGWx** card to be placed on hold, queuing messages for all of the **AS's ASPs** assigned to the card. Because multiple **ASs** can effectively be assigned to one card, multiple instances of $T(r)$ can be in effect at one time controlling the same **L3_L2** queue.

The net result is that the total time the **L3_L2** queue is on hold is longer than the duration of the first timer instance, and is not predictable. Because the delay between multiple instances of the timer can't be predicted, the overlap can't be predicted. If each **AS** is assigned a different value of $T(r)$, this complicates the problem. Therefore, the total time the queue can be on hold is bounded by either an absolute 200 ms, or by the queue depth exceeding congestion thresholds.

Tekelec's implementation will not account for the **ASP ID** Race Condition. If two **ASPs** send **ASP-UP** messages containing the same **ASP ID** on two different cards simultaneously, there's the potential that the same **ASP ID** value will be assigned to both the **ASPs**.

4.66 Make DB Split Feature and GFlex MAP Layer Routing Work With Each Other (Release 46.5)

This feature allows GTT Action Services to work together with the RTDB Split Feature (120M DN and 120M IMSIs via split database). The SCCP card selection on LIM cards is done on the basis of the Opcodes from the MAP layer. If the Opcode is not supported, selection is then done on the basis of the SNP parameter. For the GTT Actions table, the dependency to activate "EPAP Data Split" and GFLEX MLR is removed and the user can use the functionality of both features together. This compatibility occurs when GTT Action is executed on GTT enabled LIM cards (in cooperation with the Add GTT on SLIC IPSPG (6500 TPS) enhancement).

The Services in GTT Action can also be configured if the 240 Million SPLIT DB feature is enabled, and vice versa.

4.67 Management of Unused User IDs (Release 21.0)

In Release 21.0, the **EAGLE** maintains the date and time that each user **ID** last successfully logged on to the **EAGLE**. During the login process, the system computes how many days have elapsed since the last successful login. If the number of elapsed days exceeds the value of the `uout` parameter, used with either the `ent-user`, `chg-user`, or `chg-secu-dflt` commands, access to the **EAGLE** is denied, and the following message is displayed to the user.

Error Message

```
E2752 Cmd Rej: UserID has become obsolete and cannot be used
```

This test for inactivity is performed after the user **ID** and password combination has been validated, and before any of the password aging tests.

The `rstlsl=yes` parameter with the `chg-user` command resets the last successful login date associated with the user to the current date. This allows that user to login to the system.

When a user **ID** is initially created, the last successful login date and time that is entered in the database is set to the date and time that the user **ID** was created. If a user **ID** is created and never used, it becomes obsolete when the number of days the user **ID** was inactive, measured from the creation date, is greater than the value of the `uout` parameter. At that time, the system does not allow a login session to be established with that user **ID**.

This feature does not apply to all user **IDs** assigned to the Security Administration command class. If the **EAGLE** detects that all user **IDs** have been inactive longer than value of the `uout` parameter (for example, the system administrator mis-typed the date 10 years in the past with the `set-date` command resulting in all user **IDs** appearing obsolete to the system), no one would have access to the **EAGLE** and the **EAGLE** would be un-administrable. Since the **EAGLE** requires at least one user **ID** to be assigned to the Security Administration command class, by having this feature not apply to any user **IDs** assigned to the Security Administration command class ensures that at least one user will always have access to the **EAGLE**.

4.68 Managing deprecation of Java Applet plugin support from Browsers (Release 16.2)

This feature makes the EPAP GUI Banner independent of Java. The Java Applet plugin is no longer needed to launch the EPAP GUI Banner. See "EPAP GUI Main Screen" in *Administration Guide* for details on the updated EPAP Banner Components.

4.69 Manual Deactivation of SRST Message (Release 21.0)

When a destination for a route becomes restricted or prohibited, the **EAGLE** starts sending signaling route set test (**SRST**) messages for that destination. This feature allows a user to manually stop sending signaling route set test messages for a specific destination on a specific route using the `dact-rstst` command. The destination of the route must be either

the **DPC** of the route, a cluster point code of a route, or an entry on the cluster routing exception list. The route's status is changed to allowed.

If the **SRST** messages for a particular destination have been manually deactivated and that destination becomes restricted or prohibited again, the `dact-rstst` command must be issued again to manually stop sending the **SRST** messages for that destination.

4.70 MAP Table Increase (Release 29.0)

Description

With the **MAP** Table Increase feature, the number of **GTT MAP** Table entries can be increased from 1024 to 2000 or 3000, independent of the **GTT** capacity. The **GTT MAP** Table is used for final global title applications. This feature is also known as the **XMAP** feature.

Hardware Requirements

All existing **SCCP ASM** cards must be replaced with **SCCP TSM** or better (**DSM**) equipment when activating **XGTT**.

All existing **SCCP ASM** cards must be replaced with **SCCP TSM** or better (**DSM**) equipment when activating **XMAP**.

4.71 Measurements Enhancements (Release 22.0)

These new measurements are being added to the **EAGLE**.

- The **GTWY** measurement report type.
- The **RBASE** measurement report type.
- These measurements in the daily reports (**MTCD** and **MTCPTH**): **OCTRETRN**, **TLNKACTV** and **MSURCERR**.
- The **MTCH** measurement report type for the **LNP** entity. This report contains measurements that apply to the **LNP** feature. The details of this report are discussed in the **LNP** Feature Notice.

The **GTWY** measurement report collects and reports gateway-related data from the **STP**. The gateway related data collected for this report is the network management and global title translation load on the **EAGLE**, and the source of this load. The level and source of pass through **TCAP** traffic is also collected. In previous releases, the **MTP** cards in the **EAGLE** did not measure the data required to be reported for the **GTWY** measurement report. In release 22.0, the **MTP** cards measure this data which is reported when requested. The **MTP** cards are polled every 30 minutes for the gateway-related data. The gateway-related data is retained by the **EAGLE** for 24 hours.

The addition of the **GTWY** measurements increases the amount of measurements data collected and reported. To make sure that no measurements data is lost when the data is printed on a printer, Release 22.0 requires that the minimum baud rate of the printer is 9600 bps and that the printer must be able to print at a minimum at 1200 characters per second.

The **RBASE** measurement report reports various data related to the configuration or status of the **EAGLE**'s major configurable components. The data that appears in this

report could be obtained in an existing system by issuing a variety of `rtrv-xxxx` and `rept-stat-xxxx` commands. In release 22.0, this information can be obtained by entering a single command and can be displayed in a single report. The data in this measurement report is obtained from either the database or from maintenance tasks performed on the **EAGLE**. The data is not periodically collected and stored in same the manner of other measurements data, but it is collected on demand when a **RBASE** measurement report is requested.

4.72 Measurements Platform Filename with CLLI (Release 31.3)

The Measurements Platform Filename with **CLLI** feature allows **Measurement Platform** processors on several **EAGLEs** to send their measurements reports to a single directory on a centralized **FTP** server without duplicate file name problems or overwritten files caused by multiple **EAGLEs** writing to the directory.

The Measurements Platform Filename with **CLLI** function is controlled. Feature **ON/OFF** status is controlled by a measurements option. when the option is turned **ON**, the unique **CLLI** field for each **EAGLE** is prepended to the beginning of the measurements report file name.

The only other major impact of this feature on the filenames generated to the **FTP** server is that when the option is **ON** the year is not included as a part of the name.

4.73 Measurements Platform IP Security (Release 31.6)

Description

Secure Shell defines a protocol for secure network services over any non-secure network. The **Secure Shell** utility **SFTP** is a file transfer replacement for **FTP** used for transferring Measurements Platform measurement reports.

SFTP uses the same provisioning information as **FTP** (**IP** address, username, password) and transparently replaces **FTP**. The **EAGLE OA&M IP Security Enhancements** feature provides the **Secure Shell SFTP** file transfer program on the **EAGLE** for the Measurements Platform **IP Security** feature (and for the **IP** User Interface telnet sessions).

The **EAGLE OA&M IP Security Enhancements Feature** provides tools to securely pass data across an otherwise non-secure network. Once the **EAGLE OA&M IP Security Enhancements Feature** is turned on, the **EAGLE** provides secure measurements information transfer between the **EAGLE** and the target server.

In order to use security, the target server needs to support **Secure Shell Server** with **SFTP** specified with subsystem option in **SSH** Server configuration file. When operational, the secure file transfers requires **SSHD** Server & **SFTP** server, version 2.0, to be available. (Customer responsibility)

The hardware baseline for **EAGLE 31.6** software release only supports **EDSM-2G** (870-2372-03) for the **MCP** application. If any **DSM-2G** card is presently configured to run the **MCP** application in an **EAGLE 31.6** system, it will be auto-inhibited during it's loading process. The hardware baseline is independent of activated features. Therefore if an **MCP** is provisioned in any 31.6 system, it must be running on an **EDSM-2G**.

The swap of hardware from **DSM-2G** to **EDSM-2G** for **MCPMs** must be done prior to the system being upgraded to **EAGLE 31.6**. The upgrade command will verify that all **MCP** provisioned in a system are running **EDSM-2G** prior to executing the upgrade. In event of an **MCP** running on a **DSM-2G**, the **MO** must be removed and the system will need to be booted

out of upgrade and the hardware swapped, prior to any re-attempt. This check is to prevent the loss of any **MCP** service.

If the **IP** security feature is activated before the software upgrade to Release 31.6, a secure **FTP** server should be in the Measurements **FTP** server list before starting the upgrade. The **FTP** server list can be retrieved via `rtrv-ftp-serv`. All servers listed with `app=meas` are Measurements **FTP** servers. A maximum of two can be Measurements **FTP** servers. Servers may be provisioned with the `ent-ftp-serv` command. After the **MCP** software is upgraded during **EAGLE** Upgrade to 31.6, it will immediately begin transferring files to the secure **FTP** server. If no secure **FTP** server is found, the report transfers will fail. No servers can be provisioned during upgrade, so the servers must be provisioned before upgrade in order to transfer all measurements.

The **EAGLE OA&M IP** Security Enhancements feature provides the **Secure Shell SFTP** file transfer program on the **EAGLE** for the Measurements Platform **IP** Security feature.

Once the **EAGLE OA&M IP** Security Enhancements Feature is turned on, the **EAGLE** provides secure measurements information transfer between the **EAGLE** and the target server.

Hardware Required

The Measurements Platform feature in Release 31.6, with or without use of the **IP** Security feature, requires an **MCPM** card with 32MB **FSRAM** and 2 **GB RAM** (**EDSM-2G**, part number 870-2372-03). This is a hardware baseline change for the **MCPM** to be upgraded to the **EDSM-2G**.



Note:

Release 31.X baseline hardware includes **GPSMIIs**, **HMUXs**, -10s **TDMs**. If these modules are not equipped the act-upgrade command will be rejected.

Limitations

- This feature provides secure access for the **EAGLE** transfer of data off-board to remote **SFTP** servers.
- This feature does not provide the remote **Secure Shell** client or server applications (**SSH**, **SFTP**).
- The **EAGLE OA&M IP** Security Enhancements feature is an On/Off feature. Turning on the **EAGLE OA&M IP** Security Enhancements disables the unsecure **FTP**, and telnet functions for all **MCPM** and **IPSM** cards, and enables secure data transfer. Turning off the **EAGLE OA&M IP** Security Enhancements feature disables the secure data transfer for all **MCPM** and **IPSM** cards and enables Telnet/**FTP** functions. Security cannot be enabled and disabled separately for telnet and Measurements Platform.
- If data transfer is in progress when the **EAGLE OA&M IP** Security feature is turned on or off, the transfer will be allowed to complete. Subsequent transfers will occur in the mode that is enabled by the change in the feature status (on or off, secure or not secure). The Measurements Platform entries in the **FTP** Servier table must be defined to allow the switch between secure and unsecure data transfer.

- Multiple **SFTP** sessions are not allowed on an **MCPM** card. Each **MCPM** card in an **EAGLE** system shall support one **SFTP** session, but only one session is allowed to be in progress at any given time on the Measurements Platform, regardless of the number of **MCPMs** installed.
- The Measurements Platform as **FTP** Client provides no inherent control of access to the **FTP** session (there is no available way to manually exchange server keys on the **EAGLE**). Access is controlled at the **FTP** Server. Thus, references to **IP** Security on the Measurements Platform essentially describe encryption of the data transmitted during the **FTP** session.
- There is the potential for the restart data to be over-written on **EDSMs**. Should a software error occur, the **MCPM** card will cold-reboot and request reload from mate. Should the fault occur simultaneously on both **MCPM** cards, Measurement data will be lost.

4.74 Measurements Platform—Phase 1 (Release 28.0)

Description

The Measurements Platform supports the growth path of the **EAGLE STP** beyond 700 links by providing a dedicated processor for collecting and reporting **STP**, **LNP**, **INP**, **G-Flex**, and **G-Port** Measurements data. This platform consists of multiple **MCPM (Measurement Collection and Polling Module)** cards in a primary/secondaries configuration, in which a single primary **MCPM** performs all collection and reporting functions. The secondary **MCPM** cards serve as backup for the primary.



Note:

The measurements platform is required for customers with more than 700 links.

The following figure presents a logical diagram of the Measurements Platform and its interfaces to the customer's network and the existing **EAGLE** architecture. The **EAGLE** interface is via the standard **IMT** bus, and allows communications with the network elements and the **OAM**. The interface to the customer's network supports the **FTP** transfer of Measurements reports to an **FTP** server.

Refer to the **Database Administration Manual - System Management** for configuration information. Refer to the **Maintenance Manual** for detailed measurements information.

Figure 4-20 Measurements Platform Architecture

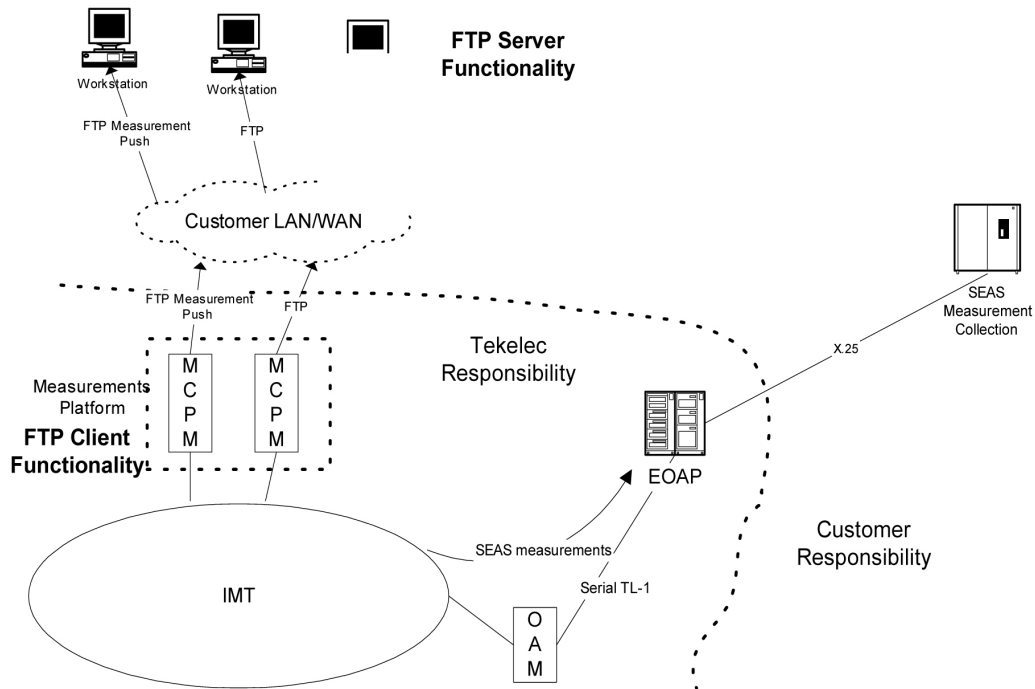

Hardware Required

The Measurements Platform requires a minimum of 2 **MCPM** cards with at least 2 **GB** of memory. For Release 28.0, the **Measurement Platform** uses **GPSM-II** based cards (P/N 850-0622-01) as the **MCPM** cards.

Caution:

Never install or initialize **MCAP** cards in **MASP** slots 1113 and 1115 after features that require **GPSM-II** cards are provisioned. Attempting to initialize **MCAP** cards with **GPSM-II** features provisioned will cause a system outage. Before replacing an existing **GPSM-II** card in a **MASP** slot (1113 and 1115) contact Tekelec Customer Service.

During card boot up, the amount of memory in the card is verified; if it is less than 2 **GB**, the card is inhibited.

For detailed information on hardware, refer to the **NSD Hardware Manual**.

4.75 Message Flow Control Replacement for TVG (Release 44.0)

Message Flow Control (MFC) provides a framework to control the flow of data between cards based on the capacity of the services provided by the cards. The MFC framework can be used to replace the Group Ticket Voucher (TVG) framework.

When a server card determines that the capacity for a service is reached, the service is considered to be '**in flow control**'. The server card broadcasts a message to all cards indicating that the service is not available for the remainder of a configured time slice and specifies the interval that defines the remainder of the time slice. When the time slice expires, the service is automatically marked available again on all client cards, and the server card is considered to be '**out of flow control**'.

MFC supports two service types:

- **Card Services** are provided by a card, and the capacity stated by that card service only affects the usage of that card. If the capacity of a card service is exhausted, only that service on that card is affected. The client card can obtain the service from another card. A card service is used for features with an 'N+1' configuration.
- **System Services** are provided by the system as a whole. Several cards can provide the same system service, and each card can have a different rated capacity. A service request that is sent to a system service is sent to all cards that provide the service. If the capacity of the system service is exhausted on one card, the service for the whole system group is in flow control. A system service is used when the available pool of resources must be limited by the weakest link (the card with the lowest rated capacity).

When an application that is using the MFC framework needs to use a service, the application looks through a list of cards or services and makes a service request. For card services, if the desired card is in flow control, the application selects a different card and uses MFC to qualify its flow control status. For system services, if any card providing a system service is in flow control, the application has to wait until the system service is out of flow control.

4.75.1 Feature Control Requirements

MFC is provisioned using the `on=mfc` option in the `chg-stpopts` command. After MFC has been provisioned, the [My Oracle Support \(MOS\)](#) must be contacted to return control to TVG.

4.76 MFC for EROUTE (Release 44.0)

Message Flow Control (MFC) can be used to control EROUTE traffic from the MTP/OAM application to the EROUTE application. If MFC is off, then TVG is used for flow control (for cards that support TVG).

See [Message Flow Control Replacement for TVG \(Release 44.0\)](#) for additional information about MFC, including Feature Control and Hardware Requirements.

4.77 MFC for MTP3 (Release 44.0)

Message Flow Control (MFC) can be used to control the flow for INM and SNM MSUs and MTP layer 3 routing. If MFC is off, then TVG is used for flow control for INM and SNM (for cards that support TVG), and for the linkset rerouting that is used in MTP Layer 3 routing.

See [Message Flow Control Replacement for TVG \(Release 44.0\)](#) for additional information about MFC, including Feature Control and Hardware Requirements.

4.78 MFC for SCCP (Release 44.0)

Message Flow Control (MFC) can be used to control the flow of SCCP traffic between LIM cards and Service Module cards. If MFC is off, then TVG is used for flow control (for cards that support TVG).

See [Message Flow Control Replacement for TVG \(Release 44.0\)](#) for additional information about MFC, including Feature Control and Hardware Requirements.

4.79 MFC for SLAN (Release 44.0)

Message Flow Control (MFC) can be used to control STP LAN service requests. If MFC is off, then TVG is used for flow control (for cards that support TVG).

See [Message Flow Control Replacement for TVG \(Release 44.0\)](#) for information on MFC, including Feature Control and Hardware Requirements.

4.80 Miscellaneous Command Adjustments (Release 26.0)

Refer to the *Commands Manual* for current command usage information.

Activate Echo to a Terminal

Customers want the ability to echo a terminal to another terminal(s), in addition to a printer. This capability will allow customers to monitor terminal command input and output from another terminal. This will also allow Tekelec's Technical Services group to monitor customer terminal activity while dialed in on a customer's switch.

Also, during upgrades, this feature will allow Technical services to monitor what the customer is entering into the terminal, step-by-step.

Note that unsolicited output (alarm and network messages) still require the `chg-trm` command to be sent to the screen.

The terminal receiving the echo must be logged on.

Figure 4-21 Echoing Remote Terminal Input/Output

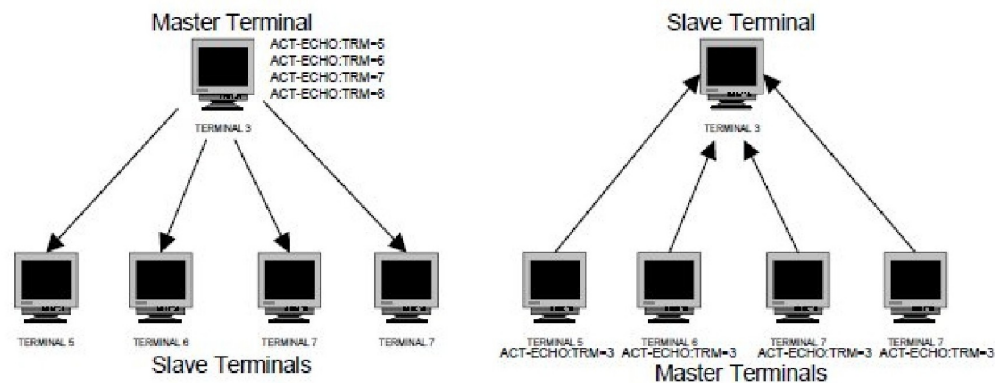

4.81 Miscellaneous Command Adjustments (Release 26.1)

Customers desire multiple enhancements to the administration functionality for the **OAM**. The following sections describe the enhancements implemented for Release 26.1.

Different Database Level Alarm Repetition When UAM 34 Has Been Raised (PR28908)

When a card in the system is at a different database level than the active **OAM**, a **UAM 34** is sent to the terminal. Because this occurs only once, operators may not notice the alarm at the card, or might enter a `rtrv-trbl` command to see that the card's database is inconsistent with the **OAM**. Customers wish to have this alarm added to the list of alarms that are reissued to the terminal at prescribed intervals.

For every card in the **EAGLE** system that is at a different database level than the active **OAM**, **UAM 34** is logged and issued to the terminal 30 minutes after the database mismatch occurs, and 30 minutes thereafter.

Output Example

```
**      Alarm Summary: Card database is inconsistent   (xxx of yyy shown)
**
-----
**      card 1101,  card 1201,  card 1202,  card 1203,  card 3113,  card
1314,
**      card 4101,  card 4102,  card 4103,  card 4104,  card 4105,  card
4106,
```

Ent-/Chg-GTT Failure Message Should Show Overlap (PR28909)

When customers enter or modify **GTT**'s, they are able to do so for a range of Global Title Addresses. If **GTT** entries already exist within that range, the command is rejected and displayed in the scroll area. Customers want the ability to see the actual condition that caused the command to fail, instead of having to execute a `rtrv-gtt` or `rtrv-gta` command on that range.

This enhancement affects the `ent-gtt/-gta`, `chg-gtt/-gta`, and `dlt-gtt/-gta` commands.

For `ent-gtt`, the scroll area message shows the first instance of an overlap for an entry/range.

For `chg-gtt`, the scroll area message shows the first instance of the two existing entries/ranges that the user attempted to change.

Examples: VGTT feature is off:

TT	GTA	EGTA	PC	XLAT	RI
253	3037070000	30370799999	1-1-3	DPC	GT
253	3037071000	30370729999	1-1-4	DPC	GT
253	3037073000	30370799999	1-1-1	DPCSSN	SSN

The command `ent-gtt:gta=3037073333` would display an E2401 message, and the scroll area message would be displayed, since there is an overlapping range.

The command `chg-gtt:gta=3037072000:egta=3037074000` would display an E2401 message, and the scroll area message would be displayed, since the change covers two entries. (See the examples below.)

`chg-gtt`

This example shows what happens when the database contains point codes within the range of 800555000 to 800555999, and the user attempts to change a point code that overlaps that range. In this situation, error message E2401 is generated:

Error Message

```
E2401 Cmd Rej: GTA range overlaps a current range
```

Output Example

```
Enter UI command or 'exit':
chg-gtt:type=2:gta=8005550000:egta=8005555999:pc=5-5-2
chg-gtt:type=2:gta=8005550000:egta=8005555999:pc=5-5-2
Command entered at terminal #4.
    The following GTA ranges overlap the input GTA range
    START GTA          END GTA
    8005550000         8005551999
    8005552000         8005553999
    8005554000         8005555999
E2401 Cmd Rej: GTA range overlaps a current range

    CHG-GTT: MASP A - Command Aborted
```

```
dlt-gtt
```

This example shows what happens when the database contains point codes within the range of 800555000 to 800555999, and the user attempts to change a point code that overlaps that range. In this situation, error message E2401 is generated:

```
E2401 Cmd Rej: GTA range overlaps a current range
```

Output Example

```
Enter UI command or 'exit':
dlt-gtt:type=2:gta=8005550020:egta=8005555900
dlt-gtt:type=2:gta=8005550020:egta=8005555900
Command entered at terminal #4.
    The following GTA ranges overlap the input GTA range
    START GTA          END GTA
    8005550000         8005551999
    8005552000         8005553999
    8005554000         8005555999
E2401 Cmd Rej: GTA range overlaps a current range

    DLT-GTT: MASP A - Command Aborted
```

4.82 MO-Based GSM SMS NP (Release 37.5)

The **MO**-Based GSM SMS NP feature provides network information to the short message service center (**SMSC**) for subscribers using the GSM network. This information allows the SMSC to select a protocol to deliver **SMS** messages to the called party.

The MO-Based GSM SMS NP feature:

- Intercepts SMS messages after they have undergone Prepaid SMS (**PPSMS**) and Portability Check for Mobile Originated SMS (**MNPSMS**) processing and before they reach the SMSC.

 **Note:**

The MO-Based GSM SMS NP feature does not require the PPSMS or MNPSMS features to be enabled.

- Decodes the TCAP/MAP message destination address and performs lookup in the number portability (**NP**) database
- Modifies the destination address in the TCAP message with directory number (**DN**) porting information, and
- Relays the message to the SMSC

The SMSC uses the DN porting information to determine whether to forward the message to other operators or to process the message for an in-network subscriber.

The MO-Based GSM SMS NP feature applies to ForwardSM SMS MSUs with ITU TCAP/MAP for either ITU or ANSI MTP messages.

4.82.1 Options

The MO-Based GSM SMS NP feature provides the following configurable options for controlling the processing of GSM **SMS** messages:

- Modifying SMS destination address information for processing
- Outbound digit format
- When an **NP** DB lookup is considered to be successful
- Handling of sub address field in destination address

4.82.2 Feature Control Requirements

The MO-Based GSM SMS NP feature has the following feature control requirements:

- A FAK for part number 893-0194-01
- The G-Port feature must be enabled and turned on before the feature can be enabled and turned on.
- The feature cannot be enabled if LNP is enabled.
- A temporary FAK cannot be used to enable the feature.
- The feature cannot be turned off after it has been turned on.

4.82.3 Hardware Requirements

There are no additional hardware requirements for this feature.

4.82.4 Limitations

When this feature is implemented, the capacity limits for combinations of DN/IMSI will be less than what is supported today.

- Existing limit: {DN, IMSI} = {36M, 60M}, {12M, 82M} and {6M, 90M}
- New limit for EPAP 10.0: {DN, IMSI} = {36M, 52M}, {12M, 75M} and {6M, 82M}

This decrease in capacity is based on high-level engineering design for the feature. Since these combinations are not used in the field, this limitation does not affect any customers.

4.83 MO-Based IS41 SMS NP (Release 37.5)

The **MO**-based IS41 SMS NP feature provides network information to the Short Message Service Center (**SMSC**) for subscribers using the IS41 network. This information allows the SMSC to select a protocol to deliver Short Message Service Delivery Point-to-Point (**SMDPP**) messages to the called party.

The MO-Based IS41 SMS NP feature:

- Intercepts SMDPP messages after they have undergone Prepaid SMS (**PPSMS**) and Portability Check for Mobile-Originated SMS (**MNPSMS**) processing and before they reach the SMSC.

 **Note:**

The MO-Based IS41 SMS NP feature does not require the PPSMS or MNPSMS features to be enabled.

- Decodes the TCAP/MAP message destination address and performs lookup in the number portability (**NP**) database
- Modifies the destination address in the TCAP message with Directory Number (**DN**) porting information, and
- Relays the message to the SMSC

The SMSC uses the DN porting information to determine whether to forward the message to other operators or to process the message for an in-network subscriber.

The MO-Based IS41 SMS NP feature applies to ANSI TCAP/MAP and ANSI transport (**MTP** and **SCCP**) messages.

4.83.1 Options

The MO-Based IS41 SMS NP feature provides configurable options for controlling the processing of **SMDPP** messages. These options specify the following:

- How to consider SMDPP destination address for processing

- Outbound digit format
- When an **RTDB** lookup is considered to be successful
- Handling of sub-address field in destination address

4.83.2 Feature Control

The MO-Based IS41 SMS NP feature has the following feature control requirements:

- A FAK for part number 893-0195-01
- The A-Port feature must be enabled and turned on before this feature can be enabled and turned on.
- The feature cannot be enabled if the LNP feature is enabled.
- A temporary FAK cannot be used to enable the feature.
- The feature cannot be turned off after it has been turned on.

4.83.3 Hardware Requirements

There are no additional hardware requirements for this feature.

4.83.4 Limitations

When this feature is implemented, the capacity limits for combinations of DN/IMSI will be less than what is supported today.

- Existing limit: {DN, IMSI} = {36M, 60M}, {12M, 82M} and {6M, 90M}
- New limit for EPAP 10.0: {DN, IMSI} = {36M, 52M}, {12M, 75M} and {6M, 82M}

This decrease in capacity is based on high-level engineering design for the feature. Since these combinations are not used in the field, this limitation does not affect any customers.

4.84 MO SMS B-Party Routing (Release 39.1)

The MO SMS B-Party Routing feature allows global translation type (GTT) routing to be performed on IS41 MO SMDPP and GSM MO_FSM messages based on the SMS B-party digits from the MAP layer of the message.

If the B number is a short code, then a short message service (SMS) can be directed to a specific short message service center (SMSC) based on the short code dialed by the SMS sender. If the B number is the MSISDN/MDN of the SMS recipient, then the SMS can be directed to a specific SMSC based on subscriber groupings or types.

4.84.1 Feature Control Requirements

The MO SMS B-Party Routing feature has the following feature control requirements:

- The Enhanced GTT (EGTT) feature must be turned on before the MO SMS B-Party Routing feature can be enabled.
- FAK for part number 893-0246-01
- A temporary FAK cannot be used to enable the feature.

4.84.2 Hardware Requirements

The MO SMS B-Party Routing feature requires Service Module cards.

The MO SMS B-Party Routing feature cannot be enabled if a TSM card running the SCCP application is provisioned. A TSM card running the SCCP application cannot be provisioned after the feature is enabled.

4.84.3 Limitations

The MO SMS B-Party Routing feature works with only non-segmented MO SMS messages.

4.85 MO SMS Migration Enhancements (Release 40.0)

The MO SMS Migration Enhancements feature includes the addition of a new MO SMS IS41-to-GSM Migration feature and enhancements to existing MO SMS features. The addition and enhancements are discussed below.

4.85.1 MO SMS IS41-to-GSM Migration

The MO SMS IS41-to-GSM Migration feature allows IS41 to GSM Migration to occur with or without number portability. This feature also allows the IS412GSM Migration Prefix to be used for lookup instead of the routing number (**RN**) obtained from the RTDB.

4.85.1.1 Feature Control Requirements

The MO SMS IS41-to-GSM Migration feature has the following feature control requirements:

- FAK for part number 893-0262-01
- The feature can be turned on and off.
- A temporary FAK cannot be used to enable the feature.
- The feature cannot be enabled if TSM cards running the **sccp** application are present in the system.
- The feature cannot be enabled if the North American LNP (LNP ELAP Configuration) feature is enabled.
- The feature must be turned on before message processing requirements can be applied.

4.85.1.2 Hardware Requirements

The MO SMS IS41-to-GSM Migration feature requires Service Module cards. TSM cards running the **sccp** application cannot be installed after the feature is enabled.

4.85.2 Enhancements to Existing MO SMS Features

The MO SMS Migration Enhancements feature includes enhancements to existing MO SMS features. For complete descriptions of all associated commands, refer to *Commands Manual* of your EAGLE 5 ISS Release 40.0 documentation set.

- The MO-based IS41 SMS NP, MO-based GSM SMS NP, and [MO SMS IS41-to-GSM Migration](#) features can use the HomeSMSC Match with Digits option. The MO-based IS41 SMS NP and the MO SMS IS41-to-GSM Migration features can also bypass the HomeSMSC address check if the SCCP called party address (CdPA) digits do not contain the SMSC address.
The `chg/rtrv-gsmsmsopts` and `chg/rtrv-is41smsopts` commands are enhanced to allow the Home SMSC option to be provisioned for the MO-based GSM SMS, MO-based IS41 SMS NP, and MO SMS IS41-to-GSM Migration features..
- The MO-based IS41 SMS NP and [MO SMS IS41-to-GSM Migration](#) features can use the original destination address (**ODA**) in the IS41 MO SMDPP for B number lookup and prefixing instead of the destination address (**DA**).
The `chg/rtrv-is41smsopts` commands are enhanced to allow the ODA or DA to be provisioned.
- The MO-based IS41 SMS NP and [MO SMS IS41-to-GSM Migration](#) features can support the ITU lower layer protocols. The MO-based IS41 SMS NP feature adds support for the IS41 MAP / ANSI TCAP / ITU SCCP / ITU MTP protocol stack. The MO SMS IS41-to-GSM Migration feature supports the IS41 MAP / ANSI TCAP / ANSI SCCP / ANSI MTP and the IS41 MAP / ANSI TCAP / ITU SCCP / ITU MTP protocol stacks.
- The MO-based GSM SMS feature can be turned on if the GSM Mobile Number Portability (G-Port) feature (893-0172-01) is not turned on.
The `chg-ctrl-feat` command is enhanced to allow the MO-based GSM SMS NP feature to be turned on if the G-Port feature is not turned on.
- The MO-based IS41 SMS NP can be turned on if the ANSI-41 Mobile Number Portability (A-Port) feature (893-0166-01) is not turned on.
The `chg-ctrl-feat` command is enhanced to allow the MO-based IS41 SMS NP feature to be turned on if the A-Port feature is not turned on.

4.86 MO SMS NPP (Release 40.1)

The MO SMS NPP feature applies comprehensive Numbering Plan Processor (**NPP**) number conditioning and service logic execution to the following existing features:

- MO SMS B-Party Routing
- MO SMS IS41-to-GSM Migration
- MO SMS Prepaid Intercept on B-Party
- MO-based GSM SMS NP
- MO-based IS41 SMS NP
- Portability Check for MO SMS
- Prepaid SMS Intercept Phase 1 (PPSMS)

The MO SMS NPP feature causes execution of all of the above features to be controlled by NPP, whether the feature is turned on or off.

This feature also adds new MO SMS ASD and MO SMS GRN features, which are used to support Additional Subscriber Data and Generic Routing Number information, respectively.

The MO SMS NPP feature supports GSM and IS41 protocols and IS41 SMDPP and GSM Forward SM Mobile Originated messages.

4.86.1 Feature Control Requirements

The MO SMS NPP feature has the following feature control requirements:

- The feature of interest must be enabled and turned on, using its current FAK.
- The GTT feature bit and EGTT feature bit must be turned on before any of the existing features can be enabled.
- The **mosmsgcdpn** or the **mosmsgcgpn** NPP service must be turned on before the MO SMS Prepaid Intercept on B-Party or the PPSMS feature can function.
- The **mosmsgcgpn** NPP service must be turned on before the Portability Check feature can function.
- The **mosmgcdpn** NPP service must be turned on before the MO-based GSM SMS NP feature can function.
- The **mosmsicdpn** NPP service must be turned on before the MO-based IS41 SMS NP feature can function.
- The MO SMS ASD feature requires a FAK for Part Number 893-0267-01.
- The MO SMS GRN feature requires a FAK for Part Number 893-0266-01.
- The **mosmsgcdpn**, **mosmsgcgpn**, **mosmsicdpn**, or **mosmsicgpn** NPP service must be turned on before the MO SMS ASD or MO SMS GRN feature can function.
- The MO SMS ASD and MO SMS GRN features can be turned on and off.
- A Temporary FAK cannot be used to turn on the MO SMS ASD or MO SMS GRN feature.

4.86.2 Limitations

The MO SMS NPP feature has the following limitations:

- If both **migrate** and **cdpnp** Service Actions are provisioned, then the outgoing number format can only have a single format. For example, a migrated subscriber cannot be formatted with RN+DN while a ported subscriber is formatted with CC+RN+DN
- If a sub-address is present and needs to be stripped off before executing an RTDB lookup and restored with DN after the RTDB lookup, then the NPP final Formatting Action must be **dn**.

4.87 MO SMS Prepaid Intercept on B-Party (Release 39.1)

The MO SMS Prepaid Intercept on B-Party feature allows the existing Prepaid Intercept Phase 1 feature to redirect MO SMS messages based on whether the B-

Party of the subscriber is prepaid. This enhancement allows MO SMS messages for prepaid subscribers to be redirected to a different short message service center (**SMSC**) than postpaid subscribers.

**Note:**

The B-party is checked only if the A-party is not a prepaid subscriber.

This feature also allows the Prepaid Intercept Phase 1 feature to support ANSI MTP/SCCP messages.

4.87.1 Feature Control Requirements

The MO SMS Prepaid Intercept on B-Party feature has the following feature control requirements:

- The Prepaid Intercept Phase 1 feature must be enabled before the MO SMS Prepaid Intercept on B-Party option can be provisioned.
- The `chg-ppsopts:bpartychk=on` command must be specified before the option can be provisioned.

4.87.2 Limitations

The MO SMS Prepaid Intercept on B-Party feature has the following limitations:

- The feature works with only non-segmented MO SMS messages.
- The feature does not support IS41 protocol processing.

4.88 MO SMS Service Portability (Release 41.1)

Service Portability support for the MO-based SMS features determines whether Service Portability processing applies to SMDPP or MO-FSM messages for own-network subscribers. This support applies to the MO-based IS41 SMS NP and MO-based GSM SMS NP features. When Service Portability is applied, the GRN is used to prefix the Destination address in outgoing messages.

The CDPNNP NPP Service Action verifies that RTDB lookup using the conditioned digits is successful based on the GSM or IS41 MOSMSTYPE configuration option value. Service Portability processing can populate the NPP RN Formatting Action value with the GRN digits provisioned for the dialed number (**DN**), populate the SP Formatting Action value with RN/SP entity digits, and populate the SRFIMSI Formatting Action value with SRFIMSI digits from the RN/SP entity. The populated values depend on RTDB lookup and configuration option values.

Default Routing Number

A Default Routing Number (Default RN) for the MO-based IS41 SMS NP and MO-based GSM SMS NP features is introduced. This number can be used if the **HLR** address is not applicable, and a global routing number is required instead of the SP entity digits for all own-network subscribers.

This option applies to Number Portability and can be used whether the S-Port feature is on or off. The CDPNNP NPP Service Action can use the provisioned Default RN digits to populate

the RN Formatting Action value for own-network subscribers. Other Formatting Action values can be populated depending on the Default RN use and configuration option values.

SPFILL

An SPFILL option for the MO-based IS41 SMS NP and MO-based GSM SMS NP features is also introduced. This option applies to MO SMS NP functionality and can be used whether the S-Port feature is on or off. The option applies to the handling of own network subscribers and controls whether NPP populates both SP and RN Formatting Action Values.

4.89 Move GLS to EPM (Release 40.0)

The Move GLS to EPM feature moves the existing Gateway Screening Binder/Generic Loading Services software to an EPM-based hardware module. This feature introduces a new E5-TSM card (870-2943-03), which is used to download the Gateway Screening database to all cards running the **ss7** or **sccp** applications. This card can be hot-swapped with the TSM-256 cards and does not support network traffic.

The E5-TSM card is provisioned using the `ent-card:type=tsm:appl=gl` command. The card supports the new **glshc** GPL.

4.89.1 Feature Control Requirements

The Gateway Screening feature bit must be turned on before the E5-TSM card can be provisioned.

4.89.2 Hardware Requirements

HIPR cards must be installed in the shelves before the E5-TSM card can be provisioned. If HIPR cards are installed, then the E5-TSM card is hot-swappable with the TSM-256 cards.

4.90 MSISDN Truncation Support for G-Port (Release 31.6)

In some networks, the **SRI**-ack response returned by **G-Port** includes the Routing Number (**RN**) associated with a ported out number prefixed to the International **MSISDN** in the **MAP MSRN** parameter. Depending on the number of digits in the **MSISDN** and the **RN**, this prefixing could result in the **MSRN** parameter exceeding 15 digits. This can cause problems with certain **MSCs**. Therefore, a new option for **G-Port** allows a certain specified number of digits to be deleted from the beginning of the National **MSISDN** (**MSISDN** without Country Code) prior to formulating the **MSRN** parameter of the **SRI**-ack response. (This feature does not affect the encoding of any other parameters or any other messages processed by **G-Port**.)

A new option for **G-Port** allows a specified number of digits to be deleted from the beginning of the National **MSISDN** (**MSISDN** without Country Code) prior to formulating the **MSRN** parameter of the **SRI**-ack response.

4.91 MT-Based GSM MMS NP (Release 38.0)

The Mobile Terminated (MT)-Based GSM MMS NP feature allows number portability (NP) database lookup to be performed on multimedia message service (MMS) messages that are routed from a multimedia message service center (MMSC).

Note:

The MT-Based GSM MMS NP feature can be used only in conjunction with the MT-Based GSM SMS NP feature.

The MT-Based GSM MMS NP feature allows the EAGLE 5 ISS to intercept non-call related messages and reply with routing information for out-of-network destination subscribers using the following process:

1. An SRI_SM message is intercepted from the MMSC before the message reaches the home location register (HLR).
2. The message destination address (SCCP Called Party GTA), is extracted, the digits are conditioned, and lookup is performed in the NP database.
3. If the destination address/subscribers belongs to a foreign network, then a reply message is sent to the MMSC with routing information. If the destination address/subscribers belongs to a local network, then the SRI_SM message is relayed to the HLR.

The feature provides the following configurable options for controlling processing of SRI_SM messages and the content of the response:

- Selecting the MMSC response message type and digit format
- Specifying when an NP database lookup is considered to be successful
- Specifying the format of digits encoded in the response message.

4.91.1 Feature Control Requirements

The MT-Based GSM MMS NP feature has the following control requirements:

- The MT-Based GSM MMS NP feature must be enabled and turned on.
- A FAK for part Part number 893-0241-01
- The feature cannot be turned off after it has been turned on.
- A temporary FAK cannot be used to enable the feature.

4.91.2 Hardware Requirements

There are no additional hardware requirements for this feature.

4.91.3 Limitations

The 150-character limit on command line length may prevent a single `chg-gsmopts` command from being entered on a single line. If the command does not fit on one line, then the command must be broken into multiple commands.

4.92 MT-Based GSM SMS NP (Release 38.0)

The Mobile Terminated (**MT**)-Based GSM SMS NP feature allows number portability (**NP**) database lookup to be performed on SRI_SM messages. These messages are normally generated from the short message service center (**SMSC**) to determine the destination for a short message service (**SMS**) message.

The MT-Based GSM SMS NP feature allows the EAGLE 5 ISS to intercept non-call related messages and reply with routing information for out-of-network destination subscribers using the following process:

1. An SRI_SM message is intercepted from the SMSC before the message reaches the home location register (**HLR**).
2. The message destination address (SCCP Called Party GTA), is extracted, the digits are conditioned, and lookup is performed in the NP database.
3. If the destination address/subscribers belongs to a foreign network, then a reply message is sent to the SMSC with routing information. If the destination address/subscribers belongs to a local network, then the SRI_SM message is relayed to the HLR.

The feature provides configurable options for controlling processing of SRI_SM messages and the content of the response:

- Selecting the SMSC response message type and digit format
- Specifying when an NP database lookup is considered to be successful
- Specifying the format of digits encoded in the response message.

4.92.1 Feature Control Requirements

The MT-Based GSM SMS NP feature has the following control requirements:

- The `defcc` parameter in the `chg-stpopts` command must be set to a value other than **none** before the feature can be turned on.
- The `defmcc` parameter in the `chg-gsmopts` command must be set to a value other than **none** before the feature can be turned on.
- A FAK for part Part number 893-0200-01
- The G-Port feature must be enabled before the MT-Based GSM SMS NP feature can be enabled.
- The G-Port feature must be turned on before the MT-Based GSM SMS NP feature can be turned on.
- The MT-Based GSM SMS NP feature cannot be enabled if the LNP feature is enabled.
- A temporary FAK cannot be used to enable the feature.
- The feature cannot be turned off after it has been turned on.

4.92.2 Hardware Requirements

The MT-Based GSM SMS NP feature cannot be enabled if TSM cards running the **sccp** application are present in the system. A TSM card that is running the **sccp** application cannot be provisioned when this feature is enabled.

4.92.3 Limitations

The 150-character limit on command line length may prevent a single `chg-gsmopts` command from being entered on a single line. If the command does not fit on one line, then the command must be broken into multiple commands.

4.93 MT-Based IS41 SMS NP (Release 38.0)

The Mobile Terminated (**MT**)-Based IS41 SMS NP feature enhances the A-Port feature to allow wireless operators to route short message service (**SMS**) messages within a number portability (**NP**) environment. If the MT-Based IS41 SMS NP feature is not enabled and turned on, then messages are processed by the A-Port feature.

This feature provides the following configurable options for controlling processing of SMS routing request messages and the content of the response:

- Selecting the short message service center (**SMSC**) response message type and digit format
- Specifying when an NP database lookup is considered to be successful
- Specifying the format of digits encoded in the response message.

The MT-Based IS41 SMS NP feature acts as follows:

1. Intercepts an SMSREQ message from the SMSC before the message reaches the home location register (**HLR**).
2. Extracts the message destination address (SCCP Called Party GTA), conditions the digits, and performs lookup in the NP database.
3. If the destination address/subscribers belongs to a foreign network, then a reply message is sent to the SMSC with routing information. If the destination address/subscribers belongs to a local network, then the SMSREQ message is relayed to the HLR.

4.93.1 Feature Control Requirements

The MT-Based IS41 SMS NP feature (part number 893-0199-01) has the following control requirements:

- The `defcc` parameter in the `chg-stpopts` command must be set to a value other than **none** before the feature can be turned on.
- A FAK for part number 893-0199-01
- The A-Port feature must be enabled before the MT-Based IS41 SMS NP feature can be enabled.
- The A-Port feature must be turned on before the MT-Based IS41 SMS NP feature can be turned on.
- The feature cannot be enabled if the LNP feature is enabled.

- A temporary FAK cannot be used to enable the feature.
- The feature cannot be turned off after it has been turned on.

4.93.2 Hardware Requirements

The MT-Based IS41 SMS NP feature cannot be enabled if TSM cards running the **sccp** application are present in the system. A TSM card that is running the **sccp** application cannot be provisioned after the feature is enabled.

4.93.3 Limitations

The 150-character limit on command line length may prevent a single `chg-is41opts` command from being entered on a single line. If the command does not fit on one line, then the command must be broken into multiple commands.

4.94 MTP and other MRN Message Format Improvements (Release 21.0)

The following table shows the **MRNs** that have been added to Release 21.0.

Table 4-18 MRNs Added to Release 21.0

MRN	Alarm	Message Text
0010	None	MASP became standby
0061	None	Customer trouble detected
0063	Critical	Critical holdover clock trouble detected
0064	Major	Major holdover clock trouble detected
0065	Minor	Minor holdover clock trouble detected
0066	None	Holdover clock trouble cleared
0204	Minor	REPT-LKF: XER - SUERM threshold exceeded
0206	Minor	REPT-LKF: APF - lvl-2 T1 expd(not ready)
0264	None	REPT-LINK-CGST : congestion level 0 to 1
0265	None	REPT-LINK-CGST : congestion level 1 to 2
0266	None	REPT-LINK-CGST : congestion level 2 to 3
0267	None	REPT-LINK-CGST : congestion level 3 to 2
0268	None	RCVRY-LINK-CGST : congestion level 2 to 1
0269	None	RCVRY-LINK-CGST : congestion has cleared
0270	None	REPT-LINK-CGST : discard level 0 to 1
0271	None	REPT-LINK-CGST : discard level 1 to 2
0272	None	REPT-LINK-CGST : discard level 2 to 3
0273	None	RCVRY-LINK-CGST : discard level 3 to 2
0274	None	RCVRY-LINK-CGST : discard level 2 to 1
0275	None	RCVRY-LINK-CGST : discard has cleared
0300	Minor	Active OAM Grant Failure

Table 4-18 (Cont.) MRNs Added to Release 21.0

MRN	Alarm	Message Text
0301	None	Active OAM Grant Recovery
0302	Minor	CARD REPAIR: Card Auto Inhibited
0303	None	CARD REPAIR: Card Auto Uninhibited
0304	Minor	REPT-NMTSK-DSCD: SNM Discard Onset
0305	None	RECVY-NMTSK-DSCD: SNM Discard Abated
0306	Minor	SNM Overload Onset
0307	None	SNM Overload Abated
0319	Critical	REPT-MTPLP-DET: Circ rte det(cong)
0320	Critical	REPT-MTPLP-SUST: Sustained circ rte(cong)
0321	Minor	X-LIST occupancy threshold exceeded
0322	None	X-LIST occupancy below threshold
0338	Major	X-LIST space full-entry(s) discarded
0339	None	X-LIST space full condition abated
0340	None	RCVRY-MTPLP-RST: Circ rte status cleared
0341	Major	OAP unavailable
0342	Major	SEAS UAL unavailable
0343	Major	SEAS X.25 Link unavailable
0344	Minor	SEAS PVC unavailable
0345	Major	SEAS UAL unavailable
0346	Minor	SEAS PVC session unavailable
0347	None	SEAS X.25 Link is available
0348	Major	SEAS is at min service limit
0349	Critical	SEAS unavailable
0350	Critical	SEAS ports inhibited
0351	None	SEAS is available
0352	None	SEAS is removed
0353	None	OAP is available
0354	Major	One SEAS TDM Port unavailable
1083	None	GWS rcvd H0/H1 that is not allowed
1087	None	MTP RSTRT rcvd unexpected user traffic
1088	None	REPT-MTP-RSTRT MTP Restart started
1089	None	RCVRY-MTP-RSTRT MTP Restart completed
1099	None	String Data Dump
1146	None	REPT-XLST-TIMO: X- LIST entry expired
1147	None	MTP Invalid TFA received
1148	None	MTP Invalid TFR received

The following table shows the **MRNs** that have been changed from Release 20.0 to Release 21.0.

Table 4-19 MRNs Changed from Release 20.0 to Release 21.0

Release 20.0 MRN	Release 20.0 Alarm Level	Release 20.0 Message Text	Release 21.0 MRN	Release 21.0 Alarm Level	Release 21.0 Message Text
0082	Major	Alarm in Fuse Panel	0082	Minor	Alarm in Fuse Panel
0110	Minor	Minor failure detected on both IMTs	0110	Minor	Major failure detected on IMT
0200	None	SLK available: aligned	0200	None	RCVRY-LKF : link available
0201	Minor	SLK unavailable for traffic	0201	Minor	REPT-LKF : remote NE loopback
0202	None	SLK aligned	0202	Minor	REPT-LKF : HWP - too many link interrupts
0203	Minor	SLK unavailable: not aligned	0203	Minor	REPT-LKF : lost data
0205	Minor	SLK unavailable: link failure	0205	Minor	REPT-LKF : APF - Ivl-2 T1 expd (ready)
0207	Minor	SLK unavailable: remote blocked	0207	Minor	REPT-LKF : APF - Ivl-2 T3 expired
0208	Minor	SLK unavailable: local blocked	0208	Minor	REPT-LKF : APF - Ivl-2 T2 expired
0209	Minor	SLK unavailable: remote inhibited	0209	Minor	REPT-LKF : APF - failed proving period
0210	Minor	SLK unavailable: local inhibited	0210	Minor	REPT-LKF : OSA - received SIO
0211	None	SLK congestion has cleared	0211	Minor	REPT-LKF : OSA - received SIN
0212	None	SLK congestion onset from level 0 to 1	0212	Minor	REPT-LKF : OSA - received SIE
0213	None	SLK congestion onset from level 1 to 2	0213	Minor	REPT-LKF : OSA - received SIOS
0214	None	SLK congestion onset from level 2 to 3	0214	Minor	REPT-LKF : ABN - rcvcd 2 of 3 invalid BSN
0215	None	SLK discard has cleared	0215	Minor	REPT-LKF : ABN - rcvcd 2 of 3 invalid FIB
0216	None	SLK discard onset from level 0 to 1	0216	Minor	REPT-LKF : remote congestion timeout
0217	None	SLK discard onset from level 1 to 2	0217	Minor	REPT-LKF : excess acknowledge delay
0218	None	SLK discard onset from level 2 to 3	0218	Minor	REPT-LKF : COO - rcvcd changeover order
0219	None	SLK has received SIO	0219	Minor	REPT-LKF : false congestion restart

Table 4-19 (Cont.) MRNs Changed from Release 20.0 to Release 21.0

Release 20.0 MRN	Release 20.0 Alarm Level	Release 20.0 Message Text	Release 21.0 MRN	Release 21.0 Alarm Level	Release 21.0 Message Text
0220	None	SLK has received SIN	0220	Minor	REPT-LKF : MTP link restart delayed
0221	None	SLK has received SIE	0221	Minor	REPT-LKF : X25 link unavailable
0222	None	SLK has received SIOS	0222	Minor	REPT-LKF : remote FE loopback
0232	None	SLK Level-2 T2 timer expired	0232	Minor	REPT-LKF : remote blocked
0233	None	SLK Level-2 T1 timer exp (not ready)	0233	Minor	REPT-LINK-MANUAV : local blocked
0234	None	SLK Level-2 T1 timer exp (ready)	0234	Minor	REPT-LKF : RMI remote inhibited
0235	None	SLK has lost data	0235	Minor	REPT-LINK-MGTINH : local inhibited
0236	None	SLK is attempting to align	0236	Minor	REPT-LKF : not aligned
0248	None	SLK Level-3 T19 timer expired	1149	None	SLK Level-3 T19 timer expired
0253	None	SLK Inhibit denied	1150	None	SLK Inhibit denied
0254	None	SLK Inhibit response timeout	1151	None	SLK Inhibit response timeout
0255	None	SLK Uninhibit denied	1152	None	SLK Uninhibit denied
0256	None	SLK Uninhibit response timeout	1153	None	SLK Uninhibit response timeout
0317	None	Link Set allowed: RCVRY-LKSTO	0317	None	RCVRY-LKSTO : link set allowed
0318	None	Link Set prohibited: REPT-LKSTO	0318	Minor	REPT-LKSTO : link set prohibited

The following table shows the **MRNs** that have been removed from Release 21.0.

Table 4-20 Release 20.0 MRNs Removed from Release 21.0

MRN	Alarm	Message Text
0006	None	Card connected to IMT
0007	Minor	Card disconnected from IMT
0027	Major	Clock A distribution failed
0028	Major	Clock B distribution failed
0030	None	Clock A distribution normal
0031	None	Clock B distribution normal
0032	None	Clocks A and B distribution normal

Table 4-20 (Cont.) Release 20.0 MRNs Removed from Release 21.0

MRN	Alarm	Message Text
0129	Minor	Wrong card type in position
0223	None	SLK has become remotely blocked
0224	None	SLK received 2 out of 3 invalid BSN
0225	None	SLK received 2 out of 3 invalid FIB
0226	None	SLK SUERM threshold exceeded
0227	None	SLK detected remote congestion timeout
0228	None	SLK excessive delay of acknowledgment
0229	None	SLK received an unexpected SIOS
0230	None	SLK has failed proving period
0231	None	SLK Level-2 T2 timer expired
0239	None	Too many link interrupts have occurred
0240	None	SLK has received a changeover order
0241	None	SLK has been automatically canceled
0243	None	SLK has returned to service
0244	None	SLK has become locally uninhibited
0245	None	SLK has become remotely uninhibited
0246	None	SLK has become locally unblocked
0247	None	SLK has become remotely unblocked
0249	None	SLTC failure: invalid Point Code
0250	None	SLTC failure: invalid SLC
0251	None	SLTC failure: no response
0252	None	SLTC failure: bad data pattern
0257	None	SLK congestion cleared from level 2 to 1
0258	None	SLK congestion cleared from level 3 to 2
0259	None	SLK discard cleared from level 2 to 1
0260	None	SLK discard cleared from level 3 to 2

4.95 MTP Circular Route Detection (Release 21.0)

The **EAGLE** automatically tests for circular routing when congestion occurs on an **ANSI** signaling link. If the routing data were provisioned incorrectly, or were corrupted, **MSUs** could be routed in an endless circular route. The incorrect routing data could be on the **EAGLE** or at a remote **STP**. With the addition of cluster routing and E links, the danger of circular routing is greater.

The **EAGLE** starts the test when a signaling link reaches onset congestion threshold 1. The **EAGLE** only runs the test for one signaling link per linkset. If a second signaling link in the same linkset goes into congestion, the **EAGLE** does not start a new test. Each time the signaling link's congestion level increases, the test is restarted. The link interface module (**LIM**) that terminates to the congested signaling link determines which **DPCs** have the most **MSUs** transmitted on the signaling link. The **LIM** then

transmits a circular routing test message to the **DPCs** that have been sent the most **MSUs**. The circular route test message can be sent to a maximum of 10 **DPCs**. This value is configured by the `chg-stpopts` command with the `mtplctcdpcq` parameter. A circular routing test message is a routeset congestion test message with priority of 3.

If any **LIM** receives one of the test messages before the circular route test timer expires, the **EAGLE** performs the following actions.

- Marks the destination as prohibited due to circular routing.
- Broadcasts **TFPs** for the destination.
- Reports that circular routing was detected for the destination.
- Raises a critical alarm.

The circular route test timer can be configured by the user using the `chg-stpopts` command with the `mtplctst` parameter. The `mtplctst` parameter value is between 10 and 20 seconds, with 10 seconds being the default value. The **DPC** remains prohibited until it is manually allowed using the `rst-dstn` (reset destination) command.

If the destination is a cluster point code entry in the routing table, then an exception list (x-list) entry is created for the destination. If the cluster has the exception list exclusion indicator set to yes (meaning do not create x-lists for that cluster), then an x-list is not created, **UAM 319** is generated, and a critical alarm is raised for the cluster. The critical alarm can be cleared by entering the `rst-dstn` command for the cluster. The following is an example of **UAM 319**.

UAMs

```

RLGHNCXA03W 96-04-16 16:28:08 EST Rel 21.0.0
*C 0101.0319 *C DPC 011-210-*          REPT-MTPLP-DET: Circ rte det(cong)
      XMIT LSN=1s01   RC=10
      RCV LSN=1s14
      MEMBER=011-210-007

```

If the number of entries in the x-list has exceeded the maximum allowed for the x-list and circular routing is detected, then additional entries to the x-list are not added. In addition to **UAM 319** being generated, **UAM 321** is also generated. The following is an example of **UAM 321**.

```

RLGHNCXA03W 96-04-16 16:21:11 EDT Rel 21.0.0
* 0061.0321 * XLIST                    X-LIST occupancy threshold exceeded

```

When a point code is prohibited due to circular routing, the **EAGLE** ignores **TFx/TCx** management messages for that point code. The **EAGLE** does not send routeset test messages for the point code. The **EAGLE** discards any **MSUs** received for the point code and sends response method **TFPs** or **TCPs**.

When **EAGLE** detects circular routing for a destination, it sets the circular routing flag for the destination in the routing table. The `rst-dstn` command clears this flag. Once the circular routing flag is cleared, the status of the destination depends on what type of entry is used.

- If the destination is a member of a cluster for which **EAGLE** performs full point code routing only, all routes to the destination are marked as allowed and the destination's status is allowed. The **EAGLE** broadcasts **TFAs** for the destination.

- If the destination has a full point code entry in the routing table, and there is also an entry for the point code's cluster, then each route used by the point code that is also used by the cluster entry assumes the status of the route for the cluster entry. The **EAGLE** then determines the point codes route set status and broadcasts **TFA/TFR** if the point code becomes allowed or restricted.

If the `rst-dstn` command is entered for an x-list entry with the circular routing flag set, the x-list entry is deleted. The point code's status becomes the same as the cluster entry's status.

The circular route detection test feature can be turned on or off with the `mtp_lti` parameter of the `chg-stpopts` command.

The circular route detection test is not performed for **ITU** or X25 signaling links.

4.96 MTP Map Screening (Releases 31.7, 34.0)

Description

MTP MAP Screening is an enhancement to the existing **GMS/EGMS** features that adds the ability to route **MTP** traffic whose service indicator (**SI**) field is **SCCP** through the **MAP** Screening subsystem.

If the MTP MAP Screening feature is enabled and turned on and the linkset that an SCCP **MSU** arrives on has **GSMSCRN=ON**, the SCCP **MSU** arrives at the **MAP** Screening subsystem, even if it does not require **GTT**, and is **MTP**-routed. All **MAP** Screening measurements registers will contain counts for **MTP**-routed messages in addition to **GTT**-routed messages.

MTP MAP Screening added the following register to the per-path MTCH and MTCD-MAP hourly and daily MAP Screening reports:

MSCRNPAFP - Total number of messages that contained the forbidden parameter but were not rejected due to Screening action set as PASS

Hardware Required

This feature requires an **MCPM EDSM-2G** (870-2372-03) card and **DSM** cards.

4.97 MTP Messages for SCCP Applications (Release 36.0)

Description

The **MTP Messages for SCCP Applications (MTP Msgs for SCCP Apps)** feature allows **MTP**-routed **ANSI-41 LOCREQ** messages to be subject to the **A-Port**, **IS41 GSM Migration**, and G-flex processing. (The **GSM** messages are still not supported by the **IS41 GSM Migration** feature.)

The **MTP Msgs for SCCP Apps** feature can be used only when the **A-Port** feature or the **IS41 GSM Migration** feature or the **G-Flex** feature is on.

NOTE: Use of the **MTP Msgs for SCCP Apps** feature adversely affects the **SCCP** capacity, because all of the messages are counted under **SCCP** capacity.

Service Selection and Routing

All service selector options are not supported by the **MTP Msgs for SCCP Apps** feature. Only **MNP** services for the **A-Port** and **IS41 GSM Migration** features and **GFLEX** services for the **G-Flex** feature are supported by this feature.

Service re-route is not performed on **MTP**-routed messages.

If the **MTP Msgs for SCCP Apps** feature is turned on, all **SCCP** messages are routed to **SCCP** cards. **SCCP** cards perform **SCCP** decode and verification as they do for **GTT** today.

If the **MTP**-routed messages have **CDPA GTI =0** and the **IGM** feature is turned on, a message is sent for **MNP** processing. If **MNP** service is **OFFLINE**, **MTP** routing is performed on messages.

If the **MTP**-routed messages have **CDPA GTI** not zero, service selector lookup is performed using the **SCCP CDPA** information.

- If the result of the lookup is for **MNP** service, a message shall be sent to **MNP** handling. **MNP** shall check if the **TCAP** portion of the message is **ITU** or **ANSI**. If the message has **ITU TCAP**, the message is forwarded to **G-Flex** processing. If the message has **ANSI TCAP**, **A-Port** general **TCAP/MAP** verification is performed if **A-Port** or **IGM** feature is turned **ON**.
- If a service selector is not defined or does not match, or if the service is **OFFLINE**, **MTP** routing is performed on the messages. Service re-route is not performed on **MTP**-routed messages.
- Only **LOCREQ** messages are supported. See the **A-Port** and **IGM** feature descriptions for **LOCREQ** message handling.

G-Flex Feature Processing

If the result of service selector lookup is for **G-Flex** service, **G-Flex** message processing is performed. This feature supports **GFLEX** service for **MTP**-routed **TCAP/MAP** messages. If the **MTP Map Screening** feature is on, **MTP Map Screening** is performed on post **G-Flex** messages and fall-through **MTP**-routed messages.

SMS Address Conversion

SMS Address conversion is not affected by the **MTP Msgs for SCCP Apps** feature; **SMS** conversion handles only Registration Notification and **SMS** Notification messages.

Feature Access Key

A feature access key (**FAK**) for part number 893017401 is required to enable the **MTP Msgs for SCCP Apps** feature.

- The **A-Port** feature or the **IS41 GSM Migration** feature or the **G-Flex** feature must be on before the **MTP Msgs for SCCP Apps** feature can be enabled.
- After the feature is enabled and turned on, it cannot be turned off.
- No temporary **FAK** is allowed for the feature.

Hardware Requirements

The **MTP Msgs for SCCP Apps** feature requires **DSM** cards.

Limitations

None

4.98 MTP Restart (Release 21.0)

The **MTP** restart feature provides an orderly process for bringing signaling links back into service after the **EAGLE** has been restarted after being isolated. During a node's isolation, its route status information could become incorrect. When the node is restarted, the node starts carrying traffic too soon without updating its routing tables. This results in sending traffic on prohibited and restricted routes which eventually are discarded. This increases loss of traffic and also burdens the network to process this unnecessary traffic.

As routes become available or unavailable during restarting, the node acts on a per event basis and propagates the route status to the rest of the network. The sequence of route status messages broadcast depends on the sequence in which the routes became available or unavailable. This can result in sending lot of redundant network management messages. Since the route status is propagated from one node to other, this may have a ripple effect and increases the network management load of the network.

When the **MTP** restart process is used, a restarting node does not start carrying user traffic until a sufficient number of signaling links are available and the routing tables are sufficiently updated with the current status. Also, the restarting **STP** broadcasts the network management messages only after its routing table are updated. This reduces the number of unnecessary network management messages broadcast to the adjacent nodes and also makes the behavior of restarting **STP** more predictable.

The **MTP** restart process is started when the **EAGLE** detects that it has been isolated under the following conditions.

1. **SS7** application subsystem loading (after power on reset, system initialization or **SS7** application subsystem initialization). In this case, route status is lost due to memory reset.
2. When the node is totally isolated for a period of time that is equal to the isolation timer (`mtprsit`) due to all signaling link failures (for example, losing both primary and secondary clock). The isolation timer is configurable. In this case, the status of the routes may become inaccurate due to the long amount of time that the node is isolated. The **MTP** restart procedure is started only if the node is isolated for a period of time that exceeds the value of the isolation timer. The reasons for waiting for the isolation timer to expire before starting the **MTP** restart process are:
 - a. If the amount of time that the node is isolated is less than the isolation timer, the status of the routes is more accurate.
 - b. Allows the **EAGLE** to force uninhibit signaling links and come out of isolation.

The following conditions should also be met for starting a full **MTP** restart:

- The **MTP** restart feature is enabled (`chg-stpopts:mtprsi=yes`)
- There is at least one restart-capable adjacent node (linkset parameter `mtprse=yes`)

There are other conditions in which the **EAGLE** may have inaccurate route status information such as a major but partial failure of the **EAGLE**. The **MTP** restart process is not invoked in these cases. However, such failures are likely to cause adjacent nodes to become unavailable. This may result in invoking of the **MTP** restart process in the role of being adjacent to a restarting node.

The **MTP** restart process brings the signaling links back into service in four steps.

1. The signaling links are activated and traffic is stopped.
2. The **EAGLE** receives route status information from all adjacent nodes.
3. The **EAGLE** broadcasts route status information to all adjacent nodes.
4. Traffic is restarted.

User traffic is not carried on the signaling links during the **MTP** restart process. Two new protocol messages have been defined to signal the adjacent nodes when traffic may be sent on the linkset connecting the restarting node and the adjacent node.

1. Traffic-restart-waiting (**TRW**) — an indication to the receiving **STP** that no user traffic can be sent to the sending signaling point.
2. Traffic-restart-allowed (**TRA**) — an indication to the receiving **STP** that user traffic can be sent to the node sending the **TRA** message.

The route status is exchanged using Transfer (**TFx**) and Transfer **Cluster** (**TCx**) messages.

The **MTP** restart feature is supported only for **ANSI** signaling links. This feature is not supported for **ITU** and X.25 signaling links.

The time it takes to come out of isolation (when the first signaling link is available to carry level 3 traffic) is not increased due to the **MTP** restart feature.

Message Routing

Route availability has two parts:

- The network route status. This is affected by the **TFx/TCx** network management messages received from the network. The network route status is in either an **Allowed**, **Restricted**, or **Prohibited** state.
- The local route status. This is affected by changes in the linkset states. Currently, this can be either **Allowed** or **Prohibited**.

The **MTP** restart feature affects the linkset state and thus affects the local route state of all routes using that linkset. Currently a linkset can be in one of the two states, **Available** or **Not Available**. With the **MTP** restart feature, in certain states of the restart procedure, a linkset is available to carry only certain type of messages. During these states, the linkset is available to carry network management messages, signaling test, and maintenance messages that are originated and terminated at the nodes engaged in the **MTP** restart process. The linkset is not available to carry other types of messages which are commonly referred as user traffic. The user traffic includes **ISUP**, **SCCP** and management messages like **TFC** which are not originated and terminated at the nodes engaged in the **MTP** restart process. A new state **Restart** has been added to the local route status during which it is not available to carry user traffic. The local route state of a route can now be in one of three states.

- **Prohibit** — Linkset failure, same as before
- **Restart** — Because of the **MTP** restart process, the linkset cannot carry user traffic
- **Allowed** — Linkset available to carry all traffic

Aligning Signaling Links in a fully Restarting Node

During the **MTP** restart process, all adjacent nodes are sending **TFx/TCx** messages to the restarting node. To handle this burst of traffic and to avoid excessive network management load, the signaling links are activated in the following order:

1. restart-capable signaling links
2. non-restart-capable signaling links
3. X.25 signaling links

If the **MTP** restart feature is turned on, the alignment of all **ANSI** signaling links is delayed until all the **LIMs** containing **ANSI** signaling links are in service. This allows the **EAGLE** to be restored to network service in an orderly fashion and allows all the **LIMs** containing **ANSI** signaling links to participate in the **MTP** restart process. The amount of time that the alignment of the signaling links is delayed is dependent on the number of **LIMs** in the **EAGLE** and is shown in the following table.

Table 4-21 MTP Restart Signaling Link Alignment Delay

Number of LIMs Containing ANSI Signaling Links	Signaling Link Alignment Delay
1 to 64	62 seconds
64 to 127	97 seconds
128 to 191	132 seconds
192 or more	167 seconds

Measurements

One new measurement has been added to support the **MTP** restart feature.

Number of MTP Restarts Initiated —The number of times a full **MTP** restart is initiated by the **STP**. This measurement count does not include the number of times the **MTP** restart process was initiated as a result of messages from adjacent nodes.

This measurement is collected for the whole system and is reported every hour in the **STP-SYSTOT** measurement report.

Event Reporting

Two new **UIMs** have been added to support the **MTP** restart feature.

UIMs

1. Commencement of **MTP** restart process (**UIM 1088**) — This **UIM** shows that the **EAGLE** has started the **MTP** restart process. The following is an example of **UIM 1088**.

```

RLGHNCXA03W 96-04-16 16:28:08 EST Rel 21.0.0
0002.1088    SYSTEM          INFO  REPT-MTP-RSTRT MTP Restart
started
Report Date: 96-04-16  Time: 16:27:19

```

2. Completion of **MTP** Restart (**UIM 1089**) — This **UIM** shows that the **EAGLE** has completed the **MTP** restart process. The following is an example of **UIM 1089**.

```

RLGHNCXA03W 96-04-16 16:28:08 EST Rel 21.0.0
0002.1089    SYSTEM          INFO  RCVRY-MTP-RSTRT: MTP Restart

```

Completed

Report Date: 96-04-16 Time: 16:27:19

Alarms

No new alarms are required for this feature. The definition of clearing an existing alarm messages has changed because of the **MTP** restart feature.

- Critical **Alarm 0308**—Node Isolated due to **SLK** failures

This alarm is cleared when the first signaling link becomes available at level 3 and not when the **EAGLE** is ready to carry user traffic like **ISUP/SCCP**. Even though this alarm is cleared, the **EAGLE** is not available to carry user traffic because the **MTP** restart process is in progress.

4.99 MTP Routed GTT (Release 42.0)

The MTP Routed GTT feature allows Global Title Translation (GTT) and [GTT Actions \(Release 42.0\)](#) functionality to be performed on MTP-routed SCCP messages. This feature is provisioned using options in the `chg-sccpopts` command.

4.99.1 Feature Control Requirements

The MTP Msgs for SCCP Apps (Part Number 893-0174-001) or MTP Routed GWS Stop Action (Part Number 893-0356-001) feature must be turned on before the MTP Routed GTT feature can be provisioned.

For actual processing to occur, the MTP Msgs for SCCP Apps must be turned on or the MTP Routed GWS Stop Action feature must be turned on and the SCCP stop action must be provisioned.

4.99.2 Hardware Requirements

Service Module cards must be installed before the MTP Routed GTT feature can be provisioned.

4.100 Multiple Capability Point Codes (Release 21.0)

Before Release 21.0, the **EAGLE** could have only one capability point code of each network type (**ANSI**, **ITU** international, and **ITU** national) defined with the self **ID** of the **EAGLE**. With this feature, the **EAGLE** can have up to 96 capability point codes and these capability point codes can have any mixture of network types. This feature also allows the **EAGLE** to use capability point codes when performing global title translation. The capability point code identifies a group of functionally related **STPs**.

Messages requiring global title translation can be sent to other **STPs** to determine the final destination of the message. Since each **STP** has its own unique point code, the message must be sent to a specific **STP**. There can be more than one **STP** in a network that can perform the global title translation on the message. To make it easier to route these messages to **STPs**, capability point codes are assigned to the **STPs** and the global title translation tables are configured with the capability point code instead of the self **ID** point code of the **STPs** in the network. The capability point codes can be assigned to more than one **STP** in the network.

This allows other **STPs** to handle the required translation if, for example, the desired **STP** fails and no action would be required at the sending **STP** or at the other signaling points in the network to route the message to other **STPs** in the network to get the required translation.

4.101 Multiple Country Code Support for G-Port (Release 31.6)

Description

Currently, the **EAGLE's G-Port MNP** feature allows entry of one Default Country Code (**DEFCC**) per system. The **DEFCC** has four main uses in **G-Port**:

To condition non-International format **MSISDNs** received by **G-Port** prior to performing a Mobile Number Portability (**MNP**) database lookup. (All Mobile Switching **Integrated Services Digital Network** Numbers (**MSISDNs**) stored in the **MNP** database are stored in International format. Therefore, if a **MSISDN** is received in National format, **G-Port** converts it to International by appending the **DEFCC**.)

To formulate the **CC+RN+MSISDN** response format for the **MSRN** parameter in **SRI**-ack responses. (In this case, **G-Port** compares the **DEFCC** against the leading digits of the International **MSISDN** (i.e. **CC+MSISDN**) to determine where to place the **RN** returned from the database.)

To formulate the **CC+RN+MSISDN** format in the outgoing **SCCP CdPA GTA** parameter in message relay scenarios for non-**SRI** messages. (As with **MSRN** formulation, **G-Port** uses the **DEFCC** to determine where to place the **RN**).

To perform HomeRN deletion. Again, **G-Port** uses the **DEFCC** to determine which digits are the **RN**.

Certain operators wish to use a single **MNP** database to handle portability for different countries, and some areas may have more than one country code defined. In this case, due to condition 1 noted above, **G-Port** would not be able to correctly condition numbers that are received in non-International format, because it will always append the same **DEFCC**. However, because numbers must be provisioned in International format in the **MNP** database, this limitation can be easily overcome by insuring that the Mobile Switching Centers (**MSCs**) always send the **MSISDN** in the **SCCP Called Party Address (CdPA)** in International format. Therefore, no conditioning needs to be performed.

On the other hand, if these customers also require the use of the **CC+RN+MSISDN** format in the **SRI**-ack response or for message relay, **G-Port** is currently unable to handle this condition. This is because **G-Port** currently uses the **DEFCC** to determine which digits of the International number are the **CC**, and there can be only one **DEFCC** per system.

Likewise, if the **EAGLE** is configured to perform non-**SRI** message relay using the digit action of "Insert", this will cause the **SCCP CdPA** of outgoing messages to be in the format **CC+RN+MSISDN**. Using only **DEFCC**, the same problems would be encountered when constructing the outgoing **SCCP CdPA** as detailed for the **MSRN** parameter above.

The Multiple Country Code Support for **G-Port MNP** feature addresses the problem noted in condition 2 above. The **G-Port MNP** feature is modified to provide support for up to 10 "Multiple Country Codes" (MultCCs) for use in formulating the **MSRN**

parameter of the **SRI**-ack response for **G-Port** Query Response, and for constructing the **SCCP CdPA** in certain cases of **G-Port** Message Relay.

The existing `defcc` parameter in the `chg-stpopts` command will continue to be used for conditioning of numbers to International format when necessary, and will also be used for constructing the **MSRN** and **SCCP CdPA** parameters in addition to the new **MULTCC** list.

This feature provides the ability to define multiple country codes in the system (up to 10) for use by the **G-Port MNP** feature, in addition to the existing default country code (`dsefcc`).

Limitations

- For a network using multiple country codes, it is assumed that all messages needing **G-Port** service will be sent with **MSISDNs** in International format. This is true whether the **SCCP CdPA** digits or the **MAP MSISDN** digits are used for the database lookup. (This is determined by the message type and the setting of the **SRIDN** option in **G-Port**). There continues to be only one default country code (**DEFCC**) per system for conditioning of non-International **MSISDNs**. All **MSISDNs** sent in National format will be conditioned using the same system-wide **DEFCC**, regardless of the actual country code that may be assigned to the **MSISDN**.
- This feature changes only the encoding of the **MAP MSRN** parameter in the **SRI**-ack response generated by **G-Port** for a ported out number and the encoding of the **SCCP CdPA** parameter for **G-Port** message relay when Digit Action = "Insert". It does not change the encoding of the **MAP MSISDN** or **SCCP CdPA** parameters in the **SRI**-ack, or **SCCP** parameters when Digit Action is not equal to "Insert".
- The country code search is a longest match search; for example, if **MSISDN** = 12345, and two country codes are provisioned equal to 1 and 123, **G-Port MULTCC** will match on 123 for this number and consider this to be the country code. There may be cases of overlap depending upon the country code and the digits allowed by the particular numbering plan. For example, assume 1 and 123 are both valid country codes for the node. Also assume that 2345 is a valid National **MSISDN** for country code 1. This will cause a problem with **G-Port** because **MULTCC** will match on 123 for this number, and consider the National **MSISDN** to be 45 instead of 2345. Therefore, the number returned will be 123RN45 instead of 1RN2345 as it should be. Using country codes of all one length will reduce the likelihood of a mismatch occurring.

4.102 Multiple Flash Download (Release 29.0)

Description

This feature reduces the total time required to update Flash **GPLs** (i.e. board **PROM**) by providing the capability to simultaneously update, via commands, the Flash **GPL** for multiple cards.

Hardware Requirements

No new hardware is needed to support this feature.

4.103 Multiple IDP Relay Instances (Release 43.0)

The Multiple IDP Relay Instances feature allows the existing Prepaid IDP Query Relay feature (Part Number 893-0160-01) to support up to 4 IDPRCDPN NPP services (IDPRCDPN, IDPRCDPN2, IDPRCDPN3, and IDPRCDPN4) for Called Party modifications.

Each service can be configured separately to process an incoming IDP message in a different way. Refer to the *Numbering Plan Processor (NPP) Overview* for more information.

**Note:**

The combined services are referred as IDPRCDPN(X) unless a specific service must be specified.

4.103.1 Feature Control Requirements

At least one of the IDPRCDPN(X) services must be configured before the Prepaid IDP Query Relay feature can be turned on.

4.104 Multiple LFS Tests (Release 26.0)

Overview

The Multiple **Link Fault Sectionalization (LFS)** Feature allows the maintenance craftsperson to perform up to 16 **DSOA** fault sectionalization tests from the **EAGLE**. The **LFS** tests are initiated by the **EAGLE**, and are used to test the functionality of the link from the **EAGLE SS7 LIM** through multiple channel banks to a remote **Network Element**. With this feature, a craftsperson can test up to 16 **SS7** links simultaneously. An unlimited number of tests are supported if the **EAGLE** is not the integrating node for the **LFS** test.

**Note:**

The Multiple **LFS** is a debug tool provided to the craftsperson. It should be used to help isolate a link failure. Improper use of this feature can result in a link element stuck in a far-end loop-back mode. If an **LFS** test is aborted by a card reset, it could leave the remote far-end loop-back condition active. Therefore, **LFS** tests must always be cancelled by the craftsperson if they need to be aborted.

Latching versus Non-latching LFS Tests

The process of activating and maintaining a loop-back is the major difference between latching and non-latching **LFS** tests.

Non-latching loop-backs are activated by the transmission of the following sequence:

- Minimum of 40 bytes of loop-back code, in multiples of 40 bytes, transmitted continuously until a software command is received to halt transmission or begin test data transmission.
- Alternating loop-back code and test data transmitted continuously until a message is received to halt transmission.

In this case, the loop-back is dropped if every other byte transmitted is not a loop-back code.

Latching loop-backs are activated by the transmission of a sequence of pre-defined control codes. In this case, once the loop-back is established, it can only be removed by another set of pre-defined control codes.

The following figure illustrates a link from an **EAGLE** to another **EAGLE** with two **DSO** Channel banks in the path, allowing for three **LBP** for Latching **LFS** Test.

Figure 4-22 DSO Link LBPs for LLT



The following figure illustrates a link from an **EAGLE** to a **CSU/DSU** with a **DSO** and **OCU** in the path, allowing for three **LBP** for Non-Latching **LFS** Test. A loop back cannot be set in the **DSO**.

Figure 4-23 OCU/DCU link LBPs for NLT

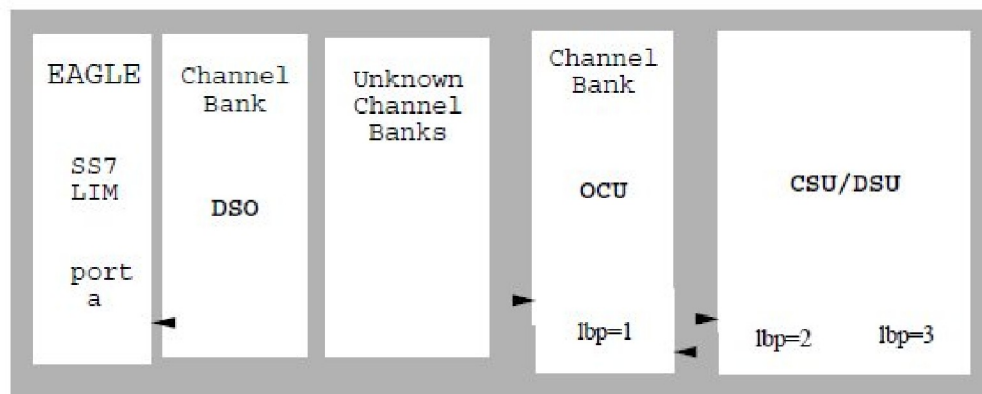

Administrative commands (`ent-lbp`, `chg-lbp`, `dlt-lbp` and `rtrv-lbp`) are used to store, change, delete and confirm the **SS7** link **RLEs** as **LBPs** in the **EAGLE** database, where the **RLE** nearest the **EAGLE** is known as **LBP one**.

The following figure shows the valid **RLE** types for **LLT** and **NLT**.

Table 4-22 Remote Link Element (RLE) Types

Element	RLE Description	Valid RLE for LLT	Valid for RLE for NLT
DSO	DSO Dataport.	Yes	No
OCU	OCU Dataport.	Yes **	Yes
CSU	CSU Dataport.	Yes **	Yes
DSU	DSU Dataport.	Yes **	Yes
NEI	Network Element Interface	Yes	No

UAM

** The OCU, CSU and DSU must be strapped/optioned to support Latching LFS loop back.

Maintenance commands (`act-lbp`, `dact-lbp`) should be used to initiate and stop the **LFS** feature. The **SS7 LIM** card must be powered up and in service with the link deactivated (**OOS_MT_DSBLD**) prior to invoking the **LFS** tests. No **SS7** traffic will be transferred to or from the signaling link by the **SS7 LIM** while the link is performing an **LFS** test.

4.105 Multiple Linksets to Single Adjacent PC (Release 37.5)

The Multiple Linksets to Single Adjacent PC (**MLS**) feature allows linksets to be established from up to 6 point codes on the EAGLE 5 ISS to a single point code on an adjacent node.

**Note:**

Multiple linksets involving IPGW links to an adjacent point code are not supported.

SLSCI Extension to ITU MSUs

With or without the MLS feature, only two linksets can have the same routing cost, which is used to loadshare across those two linksets. Even distribution of the load over all 32 links (16 links in each linkset) requires a minimum of 5 bits. ANSI MSUs have either 5-bit or 8-bit signaling link selector (**SLS**) values and meet the minimum requirements. However, ITU MSUs have 4 bit SLS values.

In order to use all 32 links in two ITU linksets, the 5-to-8 bit SLS conversion algorithm used for ANSI MSU traffic is extended to support 4-to-8 bit SLS conversion for ITU MSUs. The extended 8-bit value is used only for traffic distribution and is not included in the outgoing MSU for ITU messages.

4.105.1 Feature Control Requirements

The MLS feature has the following feature control requirements:

- A FAK for part number 893-0197-01
- After the feature is turned on, it cannot be turned off.
- A temporary FAK cannot be used to enable the feature.
- The Multiple Point Code (MPC) feature must be turned on at the EAGLE 5 ISS where the linksets originate before the feature can be enabled. It is NOT necessary for the MPC feature to be turned on at the adjacent node.

4.105.2 Hardware Requirements

The MLS feature does not have specific hardware requirements. However, the feature cannot be enabled if any of the following cards is present in the system:

- LIMDS0
- LIMV35
- LIMOCU
- ILA/EILA
- LIM-E1
- Dual-Slot DCM

If one of these cards is inserted after the feature is enabled, then the card will auto-inhibit.

4.105.3 Limitations

The MLS feature does not support multiple IPGW linksets to the same adjacent point code.

4.106 Multiple Point Code Support (Release 26.05)

Overview

Currently, the **EAGLE** supports three true point codes (one each for **ANSI**, **ITU-National**, and **ITU-International**). In addition, the **EAGLE** supports up to 96 capability point codes, each of which can be designated as either **ANSI**, **ITU-N**, or **ITU-I**. Each capability point code defined on an **EAGLE** node can be used for routing messages to that node. For various reasons, customers might need the **EAGLE** to support more than one true point code in a particular domain.

This feature adds the ability to support Secondary Point Codes (**SPCs**) in addition to the true point codes used by the **EAGLE** in any of the three domains **ANSI**, **ITU-N** and **ITU-I**. Secondary point codes are used by provisioning and routing as if they are the true point code of the **EAGLE**. **SPCs** are supported for any type of link (A, B, C, D, etc.). There is no effect on provisioning capability point codes as a result of this feature.

In addition to the one **True Point Code (TPC)** already supported for each of the **ANSI**, **ITU-N** and **ITU-I** domains, the **EAGLE** support a pool of 40 Secondary Point Codes (**SPC**), each of which may be assigned as either **ANSI**, **ITU-N**, or **ITU-I** (not to exceed a total of 40 in one system). **SPCs** can be used in the same ways that true **PCs** are used.

There are three main reasons for this feature:

1. Some customers desire to collapse multiple existing **STP**'s into one **EAGLE**. This can present problems in that end offices and other nodes may not be controlled by the carrier making reprovisioning of these network elements difficult. **Multiple Point Code (MPC)** support is designed to allow the **EAGLE** to assume more than one point code for **SS7** routing. **MPC** support is different in concept from capability point codes in that provisioning and routing will use secondary point codes as if they were the actual point code of the **EAGLE**.
2. Several customers in the international market want to deploy a single **STP** pair in multiple national (**ITU-N**) networks. This may not be possible without the **MPC** feature, as these operators are often forced to use a unique point code assigned by each national regulator of these target countries.
3. Customers may require additional links between two nodes beyond the number of links permitted by the protocol. For example, the maximum number of links between two nodes in an **ITU** network is 16. The **MPC** feature can allow for additional linksets between these nodes, increasing the number of links that can be used.

Replacing Two STP Pairs with One EAGLE Pair

The following example shows how an **EAGLE** pair can replace two existing **STP** pairs. In this example, each **EAGLE** in the pair uses one **True Point Code** and one **Secondary Point Code**.

As shown in the following figure, a new **EAGLE** first replaces one existing **STP** pair. In this case, **EAGLE**'s True Point code is set to the **True Point Code** of the old **STP**. The adjacent nodes are cut over to the **EAGLE** **STP** pair. The adjacent nodes do not need to be reconfigured.

Figure 4-24 Replacing the First STP Pair

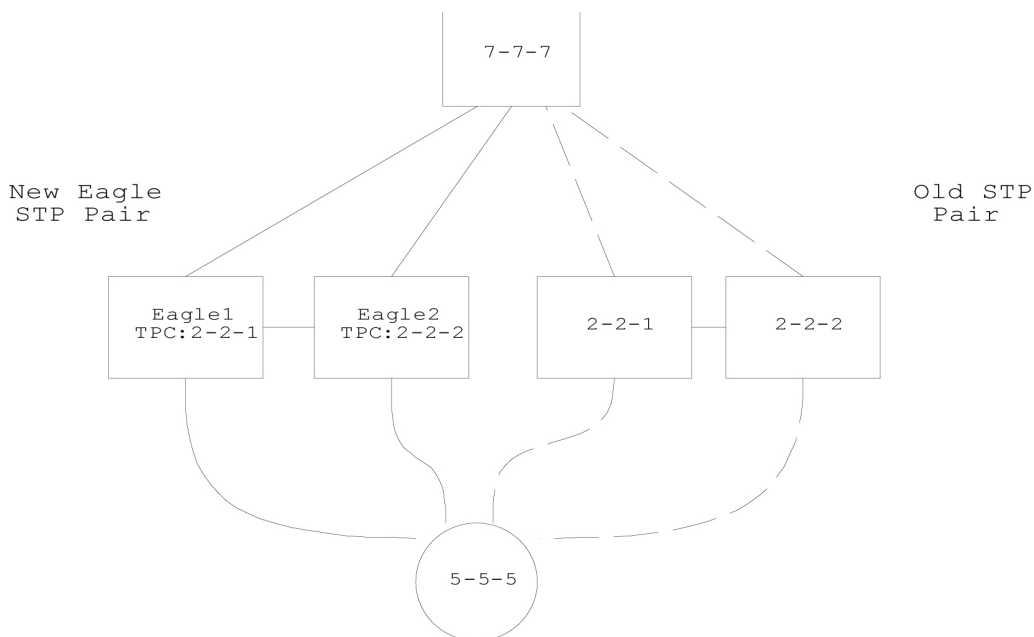

Next, a second **STP** pair is replaced with the **EAGLE** pair. As shown in the following figure, an **SSP** and an **STP** are being “re-homed” from an old **STP** pair to a new **EAGLE STP** pair. In this example, the **STP** (3-3-3) is reconfigured with new routes to recognize that it is now connected to Eagle1 and **EAGLE2** instead of 1-1-1 and 1-1-2. **STP** 3-3-3, if not an **EAGLE STP** with Multiple Point Codes, may not be able to support more than one linkset to the same point code. See “[Multiple Linksets between Two Nodes](#)” for a description of this capability. The interconnecting device (**STP** or **SSP**) can use either the **TPC** or **SPC** as the device requires.

At **EAGLE1**, the user would configure the secondary point code 1-1-1, using the `ent-spc` command. The user would also configure a route to 1-1-2 over the C-linkset. The user would then configure point code 4-4-4 in the **EAGLE**'s database to indicate that this point code uses the secondary point code 1-1-1, instead of the **EAGLE**'s true point code (`chg-dstn:dpc=4-4-4:spc=1-1-1`). This last step would be repeated for all other adjacent **SSPs** and **SCPs** that are re-homed from the old **STP** Pair to the new **EAGLE** Pair.

Similarly, at **EAGLE2**, the user would configure the secondary point code 1-1-2, and configure a route over the C-link to 1-1-1. The user would also configure point code 4-4-4 in **EAGLE2**'s database to indicate that this point code uses the secondary point code 1-1-2, instead of the **EAGLE**'s true point code.

When **EAGLE1** receives a message from the **SSP** destined for 1-1-1, **EAGLE** processes the message as if the message was sent to **EAGLE**'s True Point Code.

When **EAGLE1** generates a message (for example, Network Management, **Link Test** Messages, or **GTT** messages) that is destined for 4-4-4, **EAGLE1** puts the **OPC** 1-1-1 in the message. When **EAGLE1** generates a message that is destined for 3-3-3 or 5-5-5, it puts the **OPC** 2-2-1 in the message. When **EAGLE1** generates **GTT** and **SCMG** messages that are destined for non-adjacent **PCs**, it includes the **OPC** 2-2-1 in the message.

Figure 4-25 Replacing a Second STP Pair

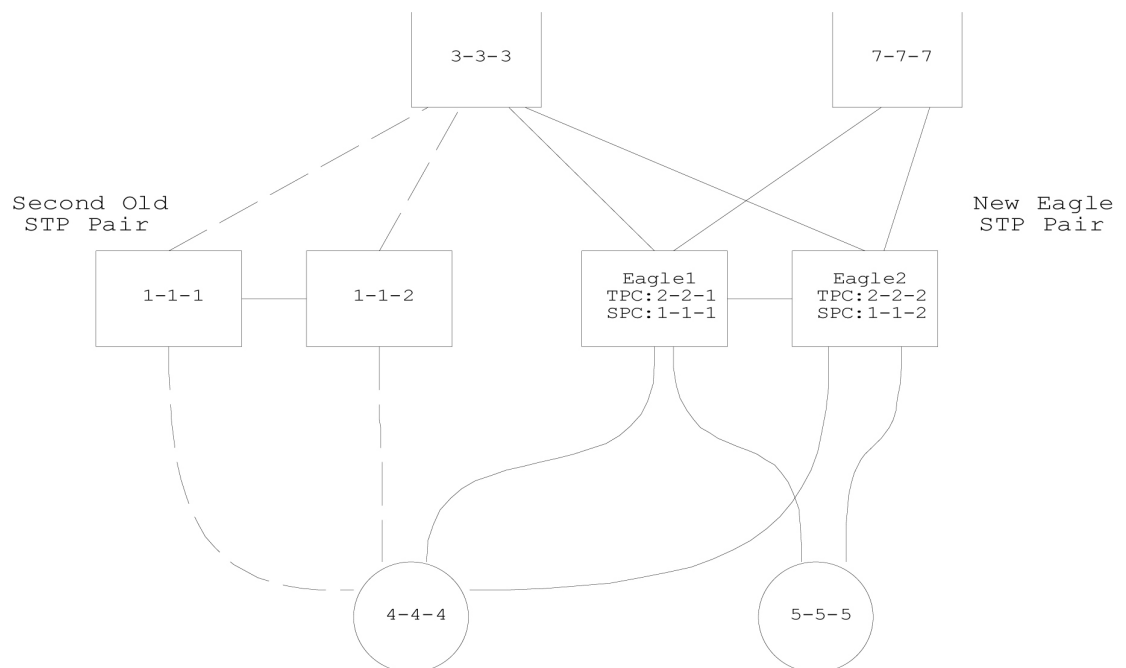

Multiple Linksets between Two Nodes

With this feature, it is possible to configure multiple linksets between two nodes, if the adjacent node also supports Multiple Point Codes. **EAGLE** continues to enforce the rule that each linkset must have a different adjacent point code.

One reason for provisioning multiple linksets between two nodes is to increase the number of links that can be configured between **STP** pairs. For example, in “[Multiple Linkset Example](#)”, **EAGLE** is connected to an **STP** pair that supports multiple point codes. Without this feature, only 16 **ITU** links can be configured between **EAGLE** and the **STP** pair (8 links in **LS1** and 8 links in **LS2**). In this example, two linksets are added, increasing the number of links to 32 (8 links in each of **LS1**, **LS2**, **LS3**, and **LS4**).

Figure 4-26 Multiple Linkset Example

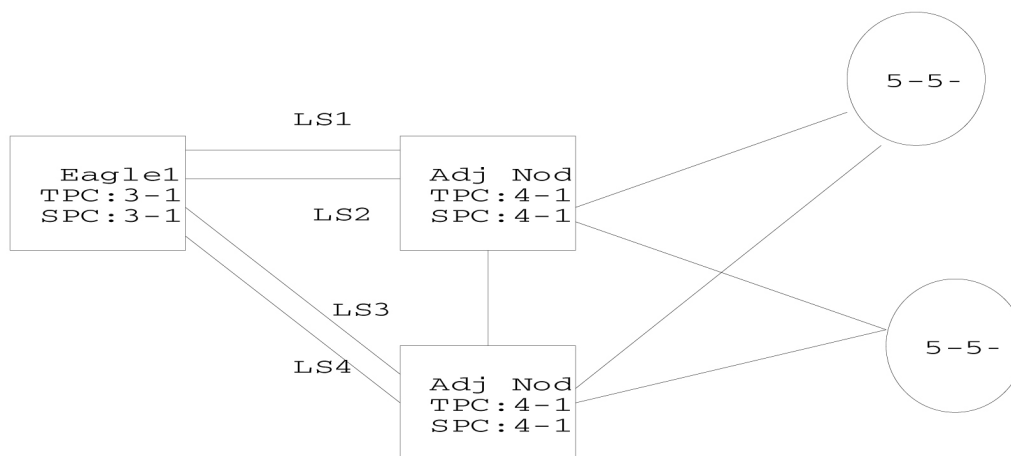

In this example, the adjacent point code (**APC**) for **LS1** is 4-1-0 and the **APC** for **LS2** is 4-1-1. 4-1-1 is assigned an **SPC** of 3-1-1. So adjacent, Adj Node1 sees **LS1** as having an **APC** of 3-1-0, and **LS2** as having an **APC** of 3-1-1.

To load balance over these 4 linksets, half the destinations that use the **STP** pair can be assigned **LS1** and **LS3** as a combined linkset. The other half of the destinations can be assigned **LS2** and **LS4** as a combined linkset.

The commands to provision **EAGLE1** for the above network are:

Input Examples

```
chg-sid:pc=3-1-0:
ent-spc=3-1-1
ent-dstn:dpc=4-1-0
ent-dstn:dpc=4-1-1:spc=3-1-1
ent-dstn:dpc=4-1-5
ent-dstn:dpc=4-1-6:spc=3-1-1
ent-dstn:dpc=5-5-1
```

```

ent-dstn:dpc=5-5-5
ent-ls:lsn=LS1:apc=4-1-0
ent-ls: lsn=LS2:apc=4-1-1
ent-ls: lsn=LS3:apc=4-1-5
ent-ls: lsn=LS4:apc=4-1-6
ent-rte:dpc=4-1-0:lsn=ls1:rc=10
ent-rte:dpc=4-1-1:lsn=ls2:rc=10
ent-rte:dpc=4-1-5:lsn=ls3:rc=10
ent-rte:dpc=4-1-6:lsn=ls4:rc=10
ent-rte:dpc=5-5-1:lsn=ls1:rc=10
ent-rte:dpc=5-5-1:lsn=ls3:rc=10
ent-rte:dpc=5-5-5:lsn=ls2:rc=10
ent-rte:dpc=5-5-5:lsn=ls4:rc=10

```

Impact on Other Features

Local Subsystems (LNP and Toll-Free)

EAGLE allows only the **True Point Code** to be entered into the **MAP** table. Also, **EAGLE** continues to allow the user to enter translations to the **True Point Code**. However, **EAGLE** does not allow the user to enter translation to a **Secondary Point Code**.

If a node sends a `rt-on-gt` query, the node should set the query's **DPC** to **EAGLE's Capability Point Code**. If a node sends a `rt-on-ssn` query, the node should set the query's **DPC** to the **TSPC** used by that node.

rt-on-gt Queries from a Node That Uses Secondary PC

Nodes that send `rt-on-gt` queries should use the **Capability PC**, regardless of whether these nodes use a **True** or a **Secondary Point Code**.

1. Node sends query with **DPC=EAGLE's LSS Capability PC**, **CDPA** is `rt-on-gt`, **CGPA PC=node's PC**
2. Result of translation on **EAGLE** is: **DPC=TPC**, **CDPA** is `rt-on-ssn`, **CDPA SSN = LSS Subsystem number**
3. **LSS** sends reply with **DPC=CGPA PC**, **OPC = SPC**, **CDPA** is `rt-on-ssn`

In this case, if the Local Subsystem on **EAGLE** fails or is taken offline, **EAGLE** sends a response method **TFP**:

TFP with **DPC = node's PC**, **OPC = SPC**, Concerned **PC = EAGLE's Capability PC**

This **TFP** causes the node to divert traffic to the mate.

If a node sends a `rt-on-gt` query to either **EAGLE's True Point Code** or a **Secondary Point Code**, **EAGLE** cannot divert traffic to the mate. In this case, **EAGLE** does not send a **TFP** concerning the **Secondary Point Code** or the **True Point Code**, so the node will not divert traffic to the mate.

rt-on-ssn queries from a Node That Uses Secondary PC

It is possible that nodes using a Secondary PC will send `rt-on-ssn` queries. In this case, these nodes should send the queries to the **Secondary Point Code**. **EAGLE** will accept `rt-on-ssn` queries from these nodes if the **DPC** is the **TPC** or an **SPC**. However, **SCCP Management** will not work correctly if the `rt-on-ssn` queries do not use **TSPC** associated with the sending node.

1. Nodes send query with **DPC=SPC**, **CDPA** is `rt-on-ssn`, **CDPA SSN = CDPA**, **SSN = LSS** Subsystem number, **CGPA PC=node's PC**
2. **LSS** sends reply with **DPC=CGPA PC**, **OPC = SPC**, **CDPA** is `rt-on-ssn`, **CGPA PC = SPC**

In this case, if the Local Subsystem on **EAGLE** fails or is taken offline, **EAGLE** broadcasts an **SSP** (assuming that the node is in the Concerned **Point Code** group):

SSP with **DPC = node's PC**, **OPC = SPC**, **Affected PC = SPC**, **Affected SSN = LSS** Subsystem number

Measurements

EAGLE pegs the following **ANSI** measurements for messages received from or destined for a different network:

- **MSURCVNA**
- **OCTRCVNA**
- **ORIGNET_30_SCCP_GTTUNTT**
- **ORIGNET_30_SCCP_GTTUNADDR**
- **ORIGNET_30_SCCP_GTTPFDCP**
- **ORIGNET_30_SCCP_GTTPFDCI**

For this feature it is likely, but not required, that the True **ANSI** point code and the **ANSI** Secondary Point codes will be in the same network. If they are in different networks, **EAGLE** uses only the network of the True **ANSI** point code to determine **EAGLE**'s network.

For example, assume that **EAGLE**'s True **ANSI** point code belongs to network A, and a Secondary point code is entered that belongs to network B. If a message arrives destined for point code in Network B (other than **EAGLE**'s **SPC**), **EAGLE** treats that message as if it were destined for a different network.

Gateway Screening

The use of the **Multiple Point Code** feature requires a customer who is also using the gateway screening feature to add provisioning rules to recognize the new site id point code provided by the **MPC** feature. Failure to add the appropriate rules could result in inappropriately blocked messages.

Provisioning Multiple Point Codes

To use this feature, the user must perform some extra steps when provisioning the **EAGLE**:

- Provision each **Secondary Point Code** using the `ent-spc` command.
- Provision a route to each of the mate's Secondary Point Codes.

- For each destination that uses a **Secondary Point Code**, enter the **Secondary Point Code** using the `ent-dstn` or `chg-dstn` command.

Upgrade Considerations

The upgrade of fielded **EAGLE** software takes into account the changes introduced by Multiple Point Codes and no degradation of system capability will occur as a result of performing the system upgrade.

Any Table Creation Utility (**TCU**) support needed to transfer information from the single Site Id table to the planned use of a combined Site Id Table and **Secondary Point Code** table form will be provided.

The **MPC** Feature Bit will be initialized to **OFF**.

Limitations

1. The same adjacent point code cannot be used for two different links.
2. Local **EAGLE** subsystems (e.g. **LNP**) must use the **True Point Code**.

4.107 Multiple Routing Contexts (Release 34.0)

Description

EAGLE 5 ISS RELEASE 34.0 supports Multiple Routing Contexts for **M3UA** and **SUA** protocols.

In the **M3UA** and **SUA** protocols, there is a Routing Context parameter that can be used by the application to distinguish between traffic associated with different Application Servers (**ASs**).

In the original **EAGLE 5 SAS** implementation, an **Application Server** Process (**ASP**) could be assigned to only a single **AS**. A single **AS** could be associated with any number of routing keys if the routing keys do not contain a Routing Context. A single **AS** could be associated with up to 4 Routing Keys if the routing keys contain a Routing Context. However, the traffic state (**ASP-Active/ASP-Inactive**) for the **ASPs** within an **AS** could not be independently controlled using the individual Routing Contexts. This effectively restricts the traffic on each **SCTP** association to 4 Routing Contexts that must all transition their traffic state in unison. If traffic to the same far end has different Routing Context values, the original **EAGLE 5 SAS** design requires multiple **SCTP** associations to the far end in order to support independent control of the traffic state using the Routing Context.

This feature enhances the original **EAGLE 5 SAS** Routing Context implementation to allow more than one Routing Context to be assigned to a single **M3UA/SUA SCTP** association, while supporting independent control of the traffic state using the Routing Contexts. The traffic state (**ASP-Active / ASP-Inactive**) can be modified for one Routing Context independently of any other Routing Context.

The following changes to **EAGLE 5 SAS IP** functions have been made in conjunction with the Multiple Routing Contexts implementation:

- This feature removes the **ASP** entity from **M3UA** and **SUA** configuration. Although the configuration of **ASPs** is being removed from the **EAGLE 5 SAS** for this feature, the **ASP** entity still exists in the **M3UA** and **SUA** architecture. The **ASP** states (**ASP-Down**, **ASP-Inactive**, and **ASP-Active**) are still used in the **EAGLE 5 SAS** when reporting the management and traffic handling states of each **Association/AS** combination within the **EAGLE 5 SAS**.

The **rept-stat-as** command can be used to retrieve association **ASP** states and **ASP-IDs** per **AS** or per association. The **asplog** pass-through command is renamed to **ualog**, and the log entries are enhanced to include a routing context indication for all applicable log entries. The **ASPNAME** parameter in the **ent-as**, **dlt-as**, **rtrv-as** and **ualog** commands has been changed to the **ANAME** parameter.

- With the removal of the **ASP** entity in configuration, the feature allows an **M3UA/SUA** association to be assigned to more than one **Application Server (AS)**.
Each time an association is assigned to an **AS**, it requires that the **IPGWx** card which hosts the **Association** maintain a unique adapter state for the association-**AS** combination. Each time a **TALI** socket is entered, it requires that the **IPGWx** card which hosts the socket maintain an adapter state for the **TALI** socket. This feature requires that the total number of adapter states maintained by a single **IPGWx** card is less than or equal to 50. On a given **IPGWx** card, the total number of all association-to-**AS** assignments and **TALI** connections cannot exceed 50. This total number could be reached by assigning a single association to up to 50 Application Servers.
- To ensure that it is not possible for an **M3UA** or **SUA** connection to be in the **ASP-Active** state without a routing key, the last routing key containing a given **AS** may not be deleted unless all associations in the **AS** are set to **OPEN=NO**.
- Prior to this feature, many of the **IP** database tables reference other **IP** database tables using name strings. In many cases, the name strings are not resolved to existing **IP** database entries at the time of provisioning. For example, a routing key can be successfully entered with an **Application Server** Name that does not exist in the **AS** table. As another example, it is possible to have a connection with an **LHOST** that cannot be resolved to a card because the matching **IPHOST** entry does not have a corresponding **IPLNK** entry. In this case the card location for the association cannot be determined. This lack of **IP** database cross-checking at provisioning time provides flexibility in command order and eases re-mapping of **IP** database entries, but it creates complexity and allows provisioning errors to go unnoticed.

This feature modifies the **IP** database provisioning rules to require a strict order of entry and deletion in order to prevent unresolved references. The **IP** database tables must be provisioned in the following order:

 **Note:**

In previous releases, the **IPHOST** table was required to be provisioned before the **IPLNK** table for a given **IP** address. This feature reverses the required order.

1. Provision the card (**ent-card** command)
2. Provision the **IPLNK** entry with the card's **IP** address(es) (**chg-ip-lnk** command).
3. Provision the **IPHOST** entry with the card's **IP** address and host name (**ent-ip-host** command).^{*} **IPHOST** entries for local hosts (**IP** cards in this **EAGLE 5 SAS**) will be designated as "local" in the **ent-ip-host** command and must exist in the **IPLNK** table. If the entry is not specifically designated as local or remote, it defaults to "local". Attempts to enter **IPHOST** entries as "remote" are rejected if the corresponding **IP** address exists in the **IPLNK** table.

4. Provision the **Association/Socket** connections (**ent-assoc** command and **ent-appl-sock** command). The **LHOST** parameter is now mandatory for these commands. The **LHOST** and **ALHOST** of the connection must exist and must be provisioned as “local” in the **IHOST** table. The **RHOST** of the connection is not required to be provisioned in the **IHOST** table. If the **RHOST** of the connection is provisioned in the **IHOST** table, it is not required to be provisioned as “remote”.
5. Provision the **Application Server** (**ent-as** command). Each association that is added to the **AS** must exist.
6. Provision the routing key (**ent-appl-rtkey** command). For **M3UA/SUA**, the **AS** being entered into the routing key must exist. For **TALI**, each socket entered into the routing key must exist.

Deleting of configuration entities that are referenced by other configuration entities is required before the referencing configuration entities can be modified or deleted (don't break the chain).

- Before the **IP** address or hostname assigned to an **IP** card's Ethernet interface can be changed, all connections referencing the hostname must be closed, removed from any Application Servers and/or routing keys that they are assigned to, and deleted or temporarily modified to reference another valid **LHOST/ALHOST**. This requires entry of more commands than in previous releases, but it does not present any new out-of-service conditions because the card has always been required to be inhibited prior to modifying its **IP** address(es).
- The **AS** recovery timer has been relocated from the **UAPS** Timer 1 in the **UAPS** table to the **AS** table. Because with this feature a single association can now exist in more than one **AS**, the **chg-as** command is now used to modify the **AS** recovery timer (instead of the **chg-uaps** command). The timer units are in milliseconds, and the valid range is 10-2000 ms.
- This feature modifies the existing reporting of primary service state (**PST**) and secondary service state (**SST**) for all **SCTP** associations. This change in **PST** function for **SCTP** associations results in a change in the meaning of the “**IP** Connection” alarms for **SCTP** (**M3UA/SUA/M2PA**) associations only. **TALI** socket **IP** Connection alarms remain unchanged.
- This feature removes support for **M3UA/SUA** connections on **IPLIMx** cards. All **M3UA** deployments must use **IPGWx** cards only. An **EAGLE 5 SAS** containing **M3UA IPLIMx** links cannot be upgraded to this release. The **EAGLE 5 SAS** Health Check procedure has been updated to detect this condition.

The following changes have also been made for **IPGWx** functions:

- **M3UA/SUA** connections must be assigned to an **Application Server (AS)** and the **AS** must have at least one routing key assigned to transition to **ASP-Active** state.
- Validation that the **ASP-ID** received in an **ASP-UP** message is unique across connections within the **AS** will be removed (this removes Strict/Relaxed **ASP-ID** validation); as a result, the **UAPS** Parm 3 becomes undefined.
- The **chg-appl-rtkey** command no longer has the capability to override the current **AS** in a routing key to another **AS**; or the current set of sockets in a routing key to a single socket. This prevents an **M3UA** or **SUA** association from being brought into service (**ASP-ACTIVE**) without having an assigned **AS** and routing key. The **NSNAME** and **NASNAME** parameters are no longer valid for the **chg-appl-rtkey** command. The equivalent function can be accomplished using the **dlt-appl-rtkey** and **ent-appl-rtkey** commands.

Hardware Requirements

No new hardware is required for this feature.

Limitations

Currently there is no maintenance action at the **EAGLE 5 SAS** to prohibit or allow an association's traffic state for a specific **AS**. For this reason, an association that is to be added to or removed from an **AS** must be set to **OPEN=NO**, preventing it from carrying traffic in any other **AS** during these provisioning activities. The **OPEN=NO** state ensures that there are other associations in the **ASs** being modified that can carry the traffic during the provisioning activities.

4.108 Multi-Port LIM (Release 27.1) (IP⁷ Release 6.0)

Description

The Multi-Port **LIM** feature improves the functionality of **SS7** routing within **EAGLE** by increasing the number of **SS7** links the **EAGLE** handles per **LIM** card. This will allow the **EAGLE** to interact in larger **SS7** networks, and reduces the footprint of an **EAGLE** (i.e. previously 250 cards would have been required to support 500 links; now only 63 cards are required).

The Multi-Port **LIM** feature has been engineered to satisfy the following requirements:

- Increase link capacity while reducing footprint
- Increase the number of ports on a **LIM** card from the current 2 to 8.
- Support the complement of low speed links with any combination of 2-port and multi-port **LIMs**.
- Allow easy transition to higher capacity **LIM** cards.
- Support alarms for higher-capacity **LIM** cards, and a larger number of links.

No new measurements are defined in this feature.

The Multi-Port **LIM** card supports all the card functionality and table capacity currently available (as of Release 26.1) for the 2-port **LIM DS0-A** card.

The Multi-Port **LIM** card can replace a 2-port **LIM DS0-A** within the same slot.

Table 4-23 Multi-Port LIM/2-Port LIM Provisioning Matrix

Provisioned Ports (56 kps)	LIM Type	System Response
A-B	2-port	Accept card
A-B	Multi-port	Accept card
A1-B3	2-port	Reject card
A1-B3	Multi-port	Accept card

A 2-port **DS0-A LIM** can replace a Multi-Port **LIM**, depending on the number of ports provisioned.

The Multi-Port **LIM** provides mapping of ports according to the diagram in the following figure.

Figure 4-27 Multi-Port LIM to 2-Port LIM Relationship

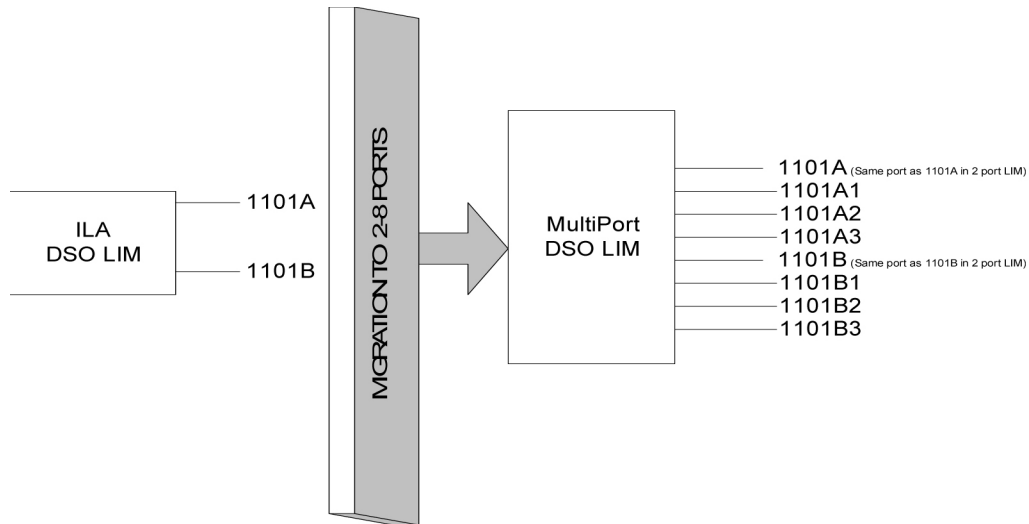

The provisioning of additional ports is not limited to a particular pattern. For example, customers can provision six ports with the following link identifiers:

Table 4-24 Link Identifier Example

1 st Port-1101A	1 st Port-1101A3
2 nd Port-1101B	2 nd Port-1101B
3 rd Port-1101A1	3 rd Port-1101A1
4 th Port-1101B1	OR 4 th Port-1101A2
5 th Port-1101A2	5 th Port-1101B2
6 th Port-1101B2	6 th Port-1101B3

Hardware Requirements

To support the increased data content in scheduled reports, terminal pacing must be increased, which requires a 19.2K baud terminal dedicated to output class **TRAFFIC**. For systems exceeding 350 links, a printer is not recommended.

For the Multi-Port **LIM** card, no new hardware other than the new **MPL** card (870-2061-01) itself is needed to support more than 8 ports.

Upgrade Considerations

Measurements data are not preserved from a prior release to the upgrade release during an upgrade. If the customer desires to retain a record of pre-upgrade measurements, a hardcopy of the measurements data can be obtained using the documented measurement report procedures. Alternatively, measurements data can be copied to a Measurements removable cartridge, using the `copy-meas` command. The data is then available for offline (non-**EAGLE**) processing. Measurements data cannot be restored to the upgraded **EAGLE**, due to potential changes in data formats as a result of the upgrade.

4.109 National Spare Network Indicator Support (Release 22.2)

The National Spare Network Indicator feature enables the **EAGLE** to support the National Spare value for Network Indicator for both **ANSI** and **ITU-National (ITU-N)** links. The National Spare Network Indicator feature is either enabled or disabled for each linkset, where the disabled state is the default condition.

Enabled States

When the National Spare Network Indicator feature is enabled for an **ANSI** linkset, the incoming message, National (10) or National Spare (11), is read and the outgoing message is forced to National Spare (11).

When the National Spare Network Indicator feature is enabled for an **ITU-N** linkset, the incoming message of International (00), National (10), or National Spare (11) is read, and the outgoing message is forced to National Spare (11).

Disabled States

When the National Spare Network Indicator feature is disabled for an **ANSI** linkset, the **EAGLE** can accept only National network indicator (10) and the outgoing message is National (10).

When the National Spare Network Indicator feature is disabled for an **ITU-N** linkset, the **EAGLE** can accept International network indicator (00) or National (10), and the outgoing message is National (10).

Gateway STP Impact

The National Spare Network Indicator impacts **ANSI** to **ITU-National** and **ITU-National** to **ANSI** message conversions when the **EAGLE** is configured as a Gateway **STP**. When enabled, the National Spare Network Indicator feature takes priority over those message conversions.

4.110 National Spare Network Indicator Support (Release 24.0)

The National Spare Network Indicator feature enables the **EAGLE** to support the National Spare value for Network Indicator for both **ANSI** and **ITU-National (ITU-N)** links. The National Spare Network Indicator feature is either enabled or disabled for each linkset, where the disabled state is the default condition.

Enabled States

When the National Spare Network Indicator feature is enabled for an **ANSI** linkset, the incoming message, National (10) or National Spare (11), is read and the outgoing message is forced to National Spare (11).

When the National Spare Network Indicator feature is enabled for an **ITU-N** linkset, the incoming message of International (00), National (10), or National Spare (11) is read, and the outgoing message is forced to National Spare (11).

Disabled States

When the National Spare Network Indicator feature is disabled for an **ANSI** linkset, the **EAGLE** can accept only National network indicator (10) and the outgoing message is National (10).

When the National Spare Network Indicator feature is disabled for an **ITU-N** linkset, the **EAGLE** can accept International network indicator (00) or National (10), and the outgoing message is National (10).

Gateway STP Impact

The National Spare Network Indicator impacts **ANSI** to **ITU-National** and **ITU-National** to **ANSI** message conversions when the **EAGLE** is configured as a Gateway **STP**. When enabled, the National Spare Network Indicator feature takes priority over those message conversions. The network indicator of the **MSU** will be the National Spare network indicator, no matter what other network indicator conversion rules are enabled for the **EAGLE**.

4.111 NEBS Compliance (Release 20.0)

The **EAGLE** will comply with the requirements of Bellcore's **TR-NWT-000063, Network Equipment-Building System (NEBS)** Generic Equipment Requirements. This document lists the generic requirements for all new telecommunications equipment systems used in central offices and other telephone buildings of a typical Bellcore Compliant Company. These requirements include:

- Spatial Requirements - vertical and horizontal space allocations within central offices for equipment frames, overhead cabling, lights, and air distribution elements.
- Environmental requirements for all new central office equipment systems including the cable distribution systems, distributing and interconnecting frames, power equipment, operations systems, and cable entrance facilities, and the methods for testing the equipment to determine if it meets the environmental requirements.

There have been no electrical or software changes made to the **EAGLE** for **NEBS** compliance. The following hardware changes have been made:

- The rear panel support brackets have now been completely welded to the frame instead of tack welded.
- The door closing mechanism is now threaded instead of notched.
- There have been minor changes made to the shelves to strengthen them.
- The end panels are now attached to the bottom of the frames with screws.

4.112 Need to decode Multiple components in a TCAP message (Release 46.5)

This feature allows TCAP Opcode Based Routing (TOBR) to check for the presence of more than one component in the MAP portion of the message. The appropriate OPCODE GTTSet is configured with the option to process multiple component sets. TOBR decodes both components, and 2 keys are formed:

- Key 1 - Package Begin/ ACN - ShortMsgGateway V3 / Opcode - ReportSMDeliveryStatus

- Key 2 - Package Begin/ ACN - ShortMsgGateway V3 / Opcode - SendSRIforSM

TOBR searches for both the keys. If both keys have matching translations in the GTTSet, then the translation with the higher priority number is chosen for TOBR processing.

EAGLE checks up to 3 components, and ignores components after the 3rd component in the message. If there are multiple components, EAGLE decodes the MAP operation of the first 3 components.

See the "TCAP Opcode Based Routing" section in *Database Administration - GTT User's Guide* for more information.

4.113 Nested Cluster Routing (Release 26.0)

Description

Nested **Cluster** Routing removes the restriction of having the full point code route on the same route as the cluster route. The **EAGLE** supports up to 500 nested cluster routes with full Network management functionality. A nested cluster route counts as 1 route entry in the route table, and does not otherwise affect the capacity of the route or xlist table.

4.113.1 Nested Clusters and Cluster Members

The cluster routing and management available in prior release of **EAGLE** software required cluster and cluster members to have same route set. With the Nested **Cluster** feature, however, users can have certain members of the provisioned cluster with different **FPC** route set. This different route set may be totally different, partially different, or exactly the same.

With the Nested **Cluster** Routing feature, routes to these members can be changed, deleted, or added. Deletion of a **FPC** route entry within a cluster will result in the member using the cluster entry for routing. Deletion of a cluster route entry will not delete the **FPC** route entry. This holds true even if the **FPC** entry and the cluster have the same route.

The **EAGLE** send cluster network management messages (**TCA**, **TCR**, **TCP**) based on the least restrictive of the cluster's route set status, and the route set status of any **FPC** entries within the cluster.

The Nested **Cluster** Routing feature provides a new routing model. (The **EAGLE** allows several routing models.) The table describes coupling between the cluster and its members. Coupling describes the relationship between the cluster and member route statuses.

Table 4-25 EAGLE Routing Models

EAGLE Routing Model	Characteristics	Issues and Resolution	Release
Full Point Code Routing (FPR) No coupling	<p>EAGLE will behave as a FPC router when CRMD feature bit is OFF. Only FPC destinations are provisioned.</p> <p>EAGLE will never generate TCX messages concerning clusters of provisioned members.</p> <p>Received TCX messages are applied to all members of the concerned cluster.</p>	No issues. There is not coupling between cluster status and member statuses due to the lack of clusters.	Rel 21
Cluster Routing (CR) No coupling NCAI=No	<p>With CRMD feature bit ON, EAGLE will allow provisioning of cluster destinations. For cluster destinations, only cluster entries are provisioned. EAGLE will generate TCX messages only for provisioned cluster destinations. All received TCX messages are applied to concerned cluster entry if it exists. Otherwise it is applied to all individual members.</p>	No issues. There is no coupling between cluster status and member status's due to the lack of members belonging to provisioned cluster.	Rel 21
Cluster Routing and Management Diversity (CRMD) Full coupling NCAI=No	<p>In this mode, EAGLE allows provisioning of clusters as well as members of same clusters. Here cluster and member have the same route set, and they are fully coupled.</p> <p>All TCX messages are applied to members and TCX messages generated by EAGLE reflect member status. In this mode, member status cannot be less restrictive than cluster.</p>	No issues regarding network management message generation and processing. Cluster and members cannot have a different route set, and thus E-links cannot be provisioned for member of a cluster.	Rel 21
Nested Cluster Routing No coupling NCAI=Yes	<p>In this mode, if the <code>ncai</code> parameter is <code>yes</code> (provided both the feature NCR and the feature CRMD are ON), the user can enter a cluster route set, then enter a different route set for a member of that cluster. In this case, member route set status can be less restricted than cluster route set status.</p>	<p>There is an issue regarding broadcasting network management messages. Because members can be less restricted than the Cluster, broadcast of cluster messages (TCA, TCR, TCP) is based on the least restrictive of the following:</p> <ul style="list-style-type: none"> The cluster's route set status The route set status of any full point code entries within the cluster <p>Also, when <code>ncai=yes</code>, EAGLE will not generate preventive TCPs.</p>	Rel 26

4.113.2 Administration

Nested **Cluster Routing (NCR)** is administered as a new feature in the **EAGLE's** database. In order to specify the `ncai` parameter (yes, no), both the **CRMD** feature and the **NCR** feature

must be **ON**. If `ncai` is `yes`, **EAGLE** allows certain members of the provisioned cluster to have different full point code route set.

If the `ncai` parameter is `no`, standard command handler rules apply (any full point code route set within a cluster must have the same route set as the cluster). If `ncai` parameter is specified as `yes`, new command handler rules apply (full point code route set can be different from the cluster route set). Following is an example of provisioning a nested cluster and associated member.

1. Turn **CRMD** feature on: `chg-feat:CRMD=ON`
2. Turn **NCR** feature on: `chg-feat:NCR=ON`
3. Enter nested cluster destination: `ent-dstn:dpc=5-5-* NCAI=yes`
4. Enter routes for nested cluster routing: Enter nested cluster's member X destination: `ent-dstn:dpc=5-5-1`
5. Enter route for associated member X: `ent-rte:dpc=5-5-1:lsn=lsA:rc=10`

Figure 4-28 Cluster Network Configuration

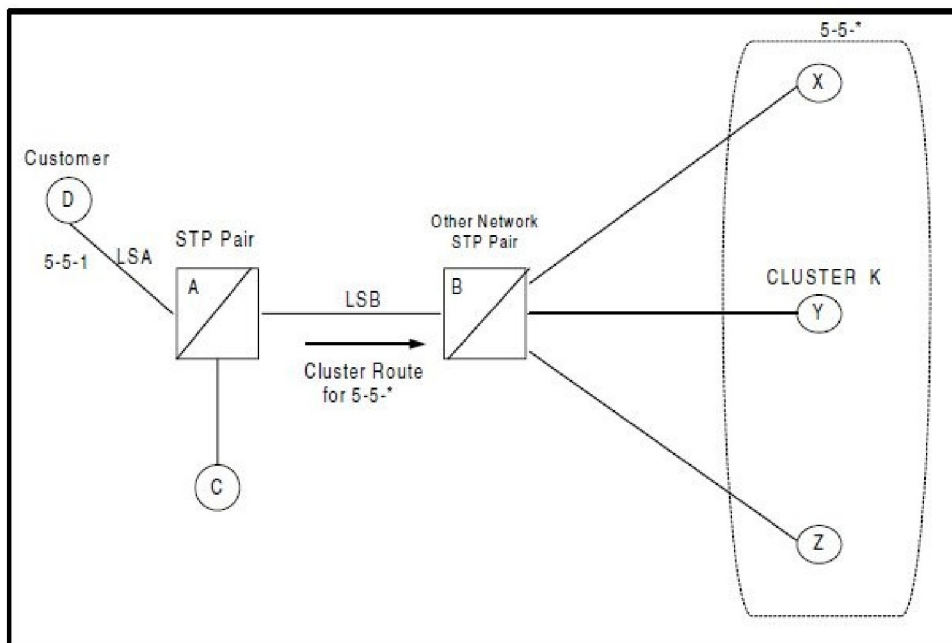

In the figure, cluster route 5-5-* exists from **STP-A** to **STP-B**. A member in that cluster, **SSP-D**, is directly connected to **STP-A**. If **SSP-C** is signaling to any member other than 5-5-1, it follows the cluster route to **STP-B**. The nested feature is used in **STP-A**.

4.113.3 General Requirements

Circular Routing

Danger of Circular Routing

Danger of circular routing means that if **EAGLE** receives an **MSU** on a linkset and then routes that **MSU**, circular routing may occur. In these cases, **EAGLE** normally sends preventive **TFPs** on these linksets.

This feature does not change the rules for determining if danger of circular routing exists for a destination and linkset. These rules are:

- Danger of **Circular Routing** only occurs on linksets that are part of the routeset for the destination
- Danger of **Circular Routing** only occurs if routing over an **STP** to a destination.
- If the linkset is a Higher cost route than the current route to the destination, there is no danger of circular routing.
- If the linkset is equal cost route as the current route to the destination, there is danger of circular routing.
- If the linkset is lower cost route than the current route to the destination, and the linkset is the least cost route, there is no danger of circular routing.

Figure 4-29 Determining If Danger of Circular Routing Exists

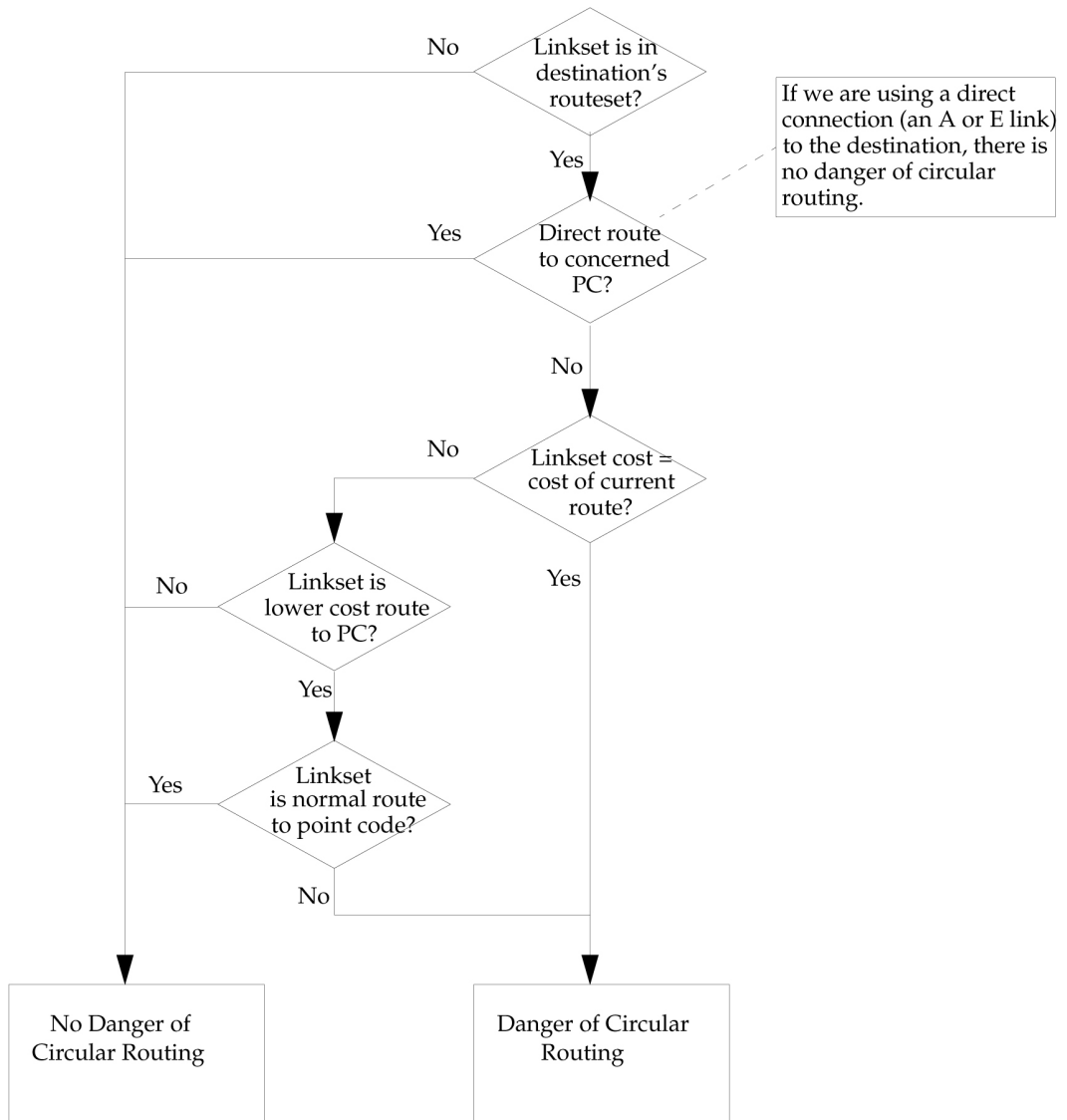

Nested Cluster Routing Rules of Operations

The following rules apply to nested clusters (cluster entries with **NCAI** set to **YES**):

1. **EAGLE** will allow the user to enter a full point code route set entry even if the point code is a member of a cluster that has a different route set.
2. When **EAGLE** performs broadcast, **EAGLE** will use the least restricted of the following to determine which cluster message (**TCA**, **TCR**, **TCP**) to send:
 - The **Cluster's** route set status
 - The route set status of any full point code entries within the cluster
3. Response method **TFP** or **TFR** will be used when the cluster destination is more restrictive than a **FPC** member. The modified **TFP** response method will send no more than one **TFP** per cluster member per T8 timer. The modified **TFR** response method sends no more than one response **TFR** per cluster member.
4. **EAGLE** will not send preventive **TCPs** when it begins routing towards a nested cluster. **EAGLE** will, however, send response method preventive **TFPs** if it receives an **MSU** when there is danger of circular routing
(Note that it will still send preventive **TFPs** when it starts routing towards a **FPC** member of a nested cluster.)
5. **EAGLE** will reply to **RCX** cluster route set test messages using the less restrictive route set status, as indicated in rule #2.
6. **EAGLE** will reply to **RSX** full point code route set messages using the full point code's route set status and danger of circular routing.

Received TFX /TCX Message Processing

For this feature, there is no change to received **TCx** message processing (although a change is required deciding whether to broadcast **TCX** messages), and there is only one change to received **TFx** message processing.

A **TFX** message received for a **FPC** member will be applied to the **FPC** member only. However, receiving a **TFX** message for a member of a nested cluster may cause **EAGLE** to broadcast a cluster message. This is a change from the way cluster routing currently works.

If **EAGLE** then receives a **TFP** from **STP** E concerning 5-5-5, **EAGLE** will apply that **TFP** to 5-5-5. Because all members of the cluster 5-5-* are at least **Restricted**, **EAGLE** will broadcast a **TCR** concerning 5-5-*. **EAGLE** will also begin routing traffic to 5-5-5 over **LSC**.

Broadcasting **TCR** (for nested cluster) will override the status of previously **TFPs** sent (for cluster members). However when traffic resumes and the conditions persists (**MSU** received and there is a danger of circular routing), **EAGLE** will again send response method **TFPs** for the affected cluster members.

EAGLE will still perform the following check for invalid **TFx** messages: If **EAGLE** receives a **TFx** message that is less restricted than the status of the route for the cluster, **EAGLE** will discard the **TFx** and generate a **UIM** (**UIM** #1147 for **TFA**, and **UIM**#1148 for **TFR**).

Generating TFX Messages

In regard to generating **TFX** messages, **FPC** members are considered individual full point code. Broadcast **TFX** messages, Preventive **TFPs** and back-routing **TFRs** are generated based on route set status and danger of circular routing. For example, in [Figure 4-28](#), when **LSE** is down, **EAGLE** will broadcast **TFR(X)** because alternate route **LSB** is still available. When **LSE** becomes available, **EAGLE** will broadcast **TFA(X)**.

If we have already sent a **TCP** (transfer cluster prohibited), we do not send a **TFP** (transfer prohibited for cluster members).

For full point code (**FPC**) members, a **TFX** condition is first broadcast and then sent in response method. If the **FPC** member's route set status is restricted, a **TFR** is broadcast after T11, then a one time response method **TFR** is sent after T18.

Generating TCX Messages

EAGLE will generate **TCX** messages based on the least restricted of the following (see rule #2):

- The **Cluster** route set status
- The route set status of any **FPC** entries within the cluster

For example, in [Figure 4-28](#), if the status of the cluster K route set changed from allowed to prohibited and the member D **FPC** route set status is allowed, **STP-A** will generate **TCA** message based on the least restricted route set status.

If all of the members in a nested cluster have the same route set status, then response method **TCX** messages will be sent after the broadcast.

If a **TCX** condition does not change but a **TFX** condition does, the **TCX** condition is not broadcast again. But if the **TCX** condition does change, then we do broadcast the new **TCX** condition.

The **EAGLE** will only broadcast **TCX** messages when the nested cluster's route set status changes. **TCR** broadcast for nested clusters should take place after the expiration of T11.

Generating RSX/RCX Messages

Generating RSX messages

Generating **RSX** messages will not change for the nested cluster feature.

Responding RSX/RCX Messages

Responding RCX Messages

EAGLE will not reply to **RCX** message when the status of the **RCX** message matches the status of the reply. If the **RCX** message is an **RCR** and the indicated reply is a **TCR**, **EAGLE** will not send a reply. If the **RCX** message is a **RCP** and the indicated reply is a **TCP**, **EAGLE** will not send a reply. If the `ncai` parameter is `yes`, the response to **RCX** messages will change.

EAGLE will reply to **Route Set Cluster** Test messages (**RCX**) using the least restrictive of the cluster's route set status and the route set status of any of the **FPC** entries within a cluster. The following table describes the **EAGLE** reply message upon reception of an **RCX** message.

Table 4-26 RCX Reply Message

Cluster Status	NCAI	Danger of Circular Routing for Cluster?	Status of Least Restricted member	Reply
A	N	N	A	TCA
A	N	Y	A	TCP
R	N	N	R	TCR
R	N	N	P	TCR
R	N	Y	R	TCP
R	N	Y	P	TCP
P	N	NA	P	TCP
A	Y	X	A	TCA
A	Y	X	R	TCA
A	Y	X	P	TCA
R	Y	X	A	TCA
R	Y	X	R	TCR
R	Y	X	P	TCR
P	Y	X	A	TCA
P	Y	X	R	TCR
P	Y	X	P	TCP

Y= Yes, N= No, NA= Not Applicable, X= Don't care, A= Allowed, P= Prohibited, R= Restricted

Responding RSX Messages

Whenever the **NCAI** parameter is set to **YES** and a **FPC** entry exists for the Concerned **PC**, **EAGLE** will reply based only on the status of the **FPC** and the danger of circular routing for the **FPC**. **EAGLE** will not reply to **RSX** message when the status of the message matches the status of the reply. If the **RSX** message is an **RSR** and the indicated reply is a **TFR**, **EAGLE** will not send a reply. If the **RSX** message is an **RSP** and the indicated reply is a **TFP**, **EAGLE** will not send a reply. The following table shows how **EAGLE** will reply when it receives a **Route Set Test (RSX)** message for a member of a cluster.

Table 4-27 RSX Reply Messages

FPC entry exists?	Cluster Status	Danger of Circular Routing for Cluster?	Status of FPC	Danger of Circular Routing for FPC?	Reply
Y	X	X	A	N	TFA
Y	X	X	A	Y	TFP
Y	X	X	R	N	TFR
Y	X	X	R	Y	TFP

Table 4-27 (Cont.) RSX Reply Messages

FPC entry exists?	Cluster Status	Danger of Circular Routing for Cluster?	Status of FPC	Danger of Circular Routing for FPC?	Reply
Y	X	X	P	NA	TFP
N	A	N	NA	NA	TFA
N	A	Y	NA	NA	TFP
N	R	N	NA	NA	TFR
N	R	Y	NA	NA	TFP
N	P	NA	NA	NA	TFP

Y= Yes, N= No, **NA**= Not Applicable, X= Don't care, A= Allowed, P= Prohibited, R= **Restricted**

Response Method TFX

Broadcasting **TFX** messages for all members of a cluster that do not have a full point code entry could create a huge amount of network management messages. For example, in a customer site of 200 nested clusters, a condition in which a B-link set fails but the E-links are available could generate 255 **TFPs** or **TFRs** per cluster, resulting in over 50,000 **TFPs** or **TFRs**. The change is not to broadcast **TFX** messages, but to send **TFX** messages by response method, with changes to the way we pace response method messages.

If a cluster destination is more restricted than a full point code member, the **STP** will send a cluster message (**TCA** or **TCR**) for the status of the least restrictive member. The **STP** will then immediately allow response method transfer messages (**TFP** or **TFR**) for individual members of the cluster. The **STP** will limit response method **TFPs** to 1 **TFP** per individual member per T8 timer. The **STP** will only send 1 **TFR** per individual member.

Response Method TFP

Once the cluster destination is inaccessible (B-link set fails but E-links are available), **EAGLE** sends a (**TCA** or **TCR**) message (cluster destination is more restricted than a full point code member). The T8 timer is started after sending the first link set response method **TFP**. **EAGLE** will send a response method **TFP** for every member of the cluster (up to 256) that does not have a provisioned **FPC** route entry.

Response Method TFR

Once the cluster destination is inaccessible (B-link set fails but E-links are available), **EAGLE** sends a (**TCA** or **TCR**) message (cluster destination is more restricted than a full point code member). T8 timer is started after sending first link set response method **TFP**. **EAGLE** will send a response method **TFP** for every member of the cluster (up to 256) that does not have a provisioned **FPC** route entry.

Preventive TCP/TFP

Normally, when **EAGLE** begins routing through an **STP** to a remote destination, **EAGLE** will send a **TFP** on any linkset where there is danger of circular routing. If the remote destination is a cluster entry with **NCAI=NO**, **EAGLE** will send a **TCP** on the linkset.

For example, in the next figure, when **EAGLE** begins routing over **LSB** to cluster K, **EAGLE** sends a preventive **TCP** concerning cluster K to **STP-B** and **STP-C**.

When `ncai=yes` for cluster, **EAGLE** will not send preventive **TCPs**. However, if **EAGLE** receives an **MSU** for the cluster on a linkset that has danger of circular routing, **EAGLE** will send a response method **TFP** and discard the **MSU**.

For example, in the next figure, when **EAGLE** begins routing over **LSB** to Cluster K, **EAGLE** will not send a **TCP** to **STP-B**. However, if **STP-B** sends **EAGLE** an **MSU** destined for 5-5-2, **EAGLE** will discard the **MSU** and send a **TFP** concerning 5-5-2 to **STP-B**. This will prevent a potential circular routing loop between **STP-B**, **EAGLE**, and **STP-A**.

Figure 4-30 Preventive TCP Example

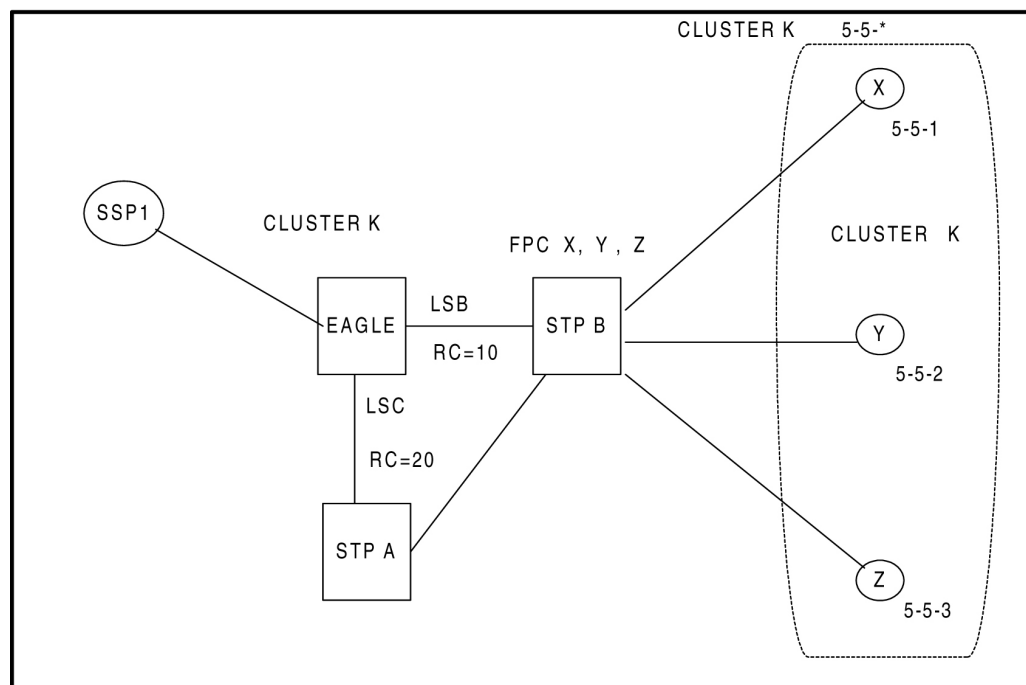

Route Table for Cluster K (5-5-*) 5-5-* **LSB, RC=10** 5-5-* **LSC, RC=20**

In the next figure, if **LSB** and the linkset between **STP-A** and **STP-B** fail, and if `NCAI=NO` for 5-5-*, **EAGLE** would send a preventive **TCP** to **STP-A** before trying to route traffic for 5-5-* over **LSC**. (Note that with `ncai=no`, **LSE** cannot be provisioned.) **STP-A** would also send a preventive **TCP** to **EAGLE** concerning 5-5-* before trying to route traffic to 5-5-* over **LSC**. After receiving the preventive **TCP** from **STP-A**, **EAGLE** would determine that the cluster 5-5-* is prohibited.

If both **EAGLE** and **STP-A** are using nested cluster routing with `ncai=yes` for 5-5-*, they will not send preventive **TCPs** when they start routing over the **LSC**. When an **MSU** destined for 5-5-2 arrives at **STP-A**, **STP-A** will route it over **LSC**.

When **EAGLE** receives the **MSU**, it will detect the danger of circular routing, and send a response method **TFP**. **STP-A** will then create an x-list for 5-5-2. When an **MSU** destined for 5-5-2 arrives at **EAGLE**, **EAGLE** will route it over **LSC**. When **STP-A** receives the **MSU**, it will detect the danger of circular routing, and send a response

method **TFP**. **EAGLE** will then create an x-list for 5-5-2. This scenario is repeated for each member of 5-5-* other than 5-5-1.

Nested Cluster Routing Examples

The next figure and table provide an example of nested cluster routing.

Figure 4-31 Nested Cluster Example #1

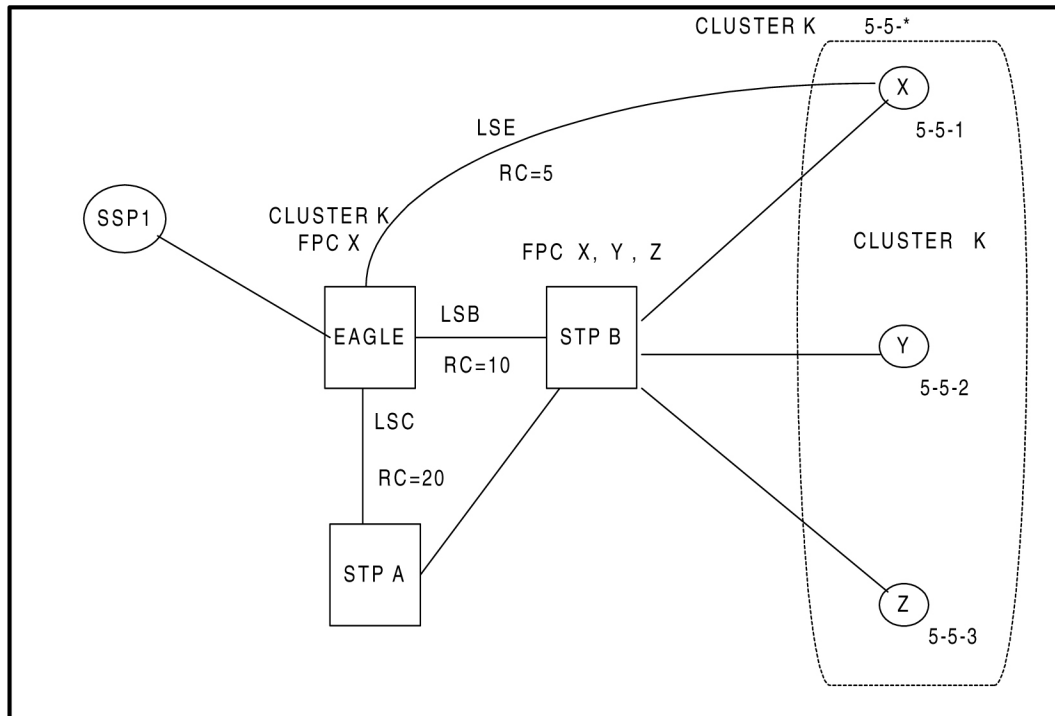

Route Table for Nested Cluster K (5-5-*)

5-5-* **LSB**, **RC=10**

5-5-***LSC**, **RC=20**

Route Table for FPC Member X (5-5-1)

5-5-1 **LSE**, **RC=5**

5-5-1 **LSB**, **RC=10**

5-5-1 **LSC**, **RC=20**

Table 4-28 Nested Cluster Routing Example

No	Event	Action
1	All link sets are up and all routes are available	EAGLE will not send preventive TCP(K) to STP-B because if K is a nested cluster, start routing messages to X using LSE and K using LSB . EAGLE will broadcast TCA(K) to SSP1 , SSP-X , STP-A , and STP-B .

Table 4-28 (Cont.) Nested Cluster Routing Example

No	Event	Action
2	Link set between STP-B and SSP-Y (5-5-2) fails, STP-B sends a TFP(Y)	EAGLE will create a (5-5-2) x-list entry and mark it to PROHIBITED on LSB . EAGLE will broadcast TFP to SSP1 , SSP-X and STP and sends response method TFP concerning 5-5-2 (Rule #3). EAGLE will start RSP for Y on LSB .
3	Link set between STP-B and SSP-X (5-5-1) fails, STP-B sends a TFP(X) to EAGLE.	EAGLE will mark FPC 5-5-1 to PROHIBITED on LSB , EAGLE routes the traffic to X via LSE . EAGLE will start RSP for X on LSB .
4	Link set between STP-B and SSP-Y(5-5-2) recovers and STP-B sends a TFA(Y) to EAGLE.	EAGLE will remove (5-5-2) x-list entry prohibited status on LSB , performs rerouting and start routing traffic to SSP-Y via LSB . EAGLE will broadcast TFA(Y) to SSP1 , SSP-X and STP-A . EAGLE sends a preventive TFP(Y) to STP-B
5	Link set between STP-B and SSP-X (5-5-1) recovers and STP-B sends a TFA(X) to EAGLE	EAGLE will mark FPC 5-5-1 to allowed status on LSB .
6	LSB fails	EAGLE will stop using LSB to send traffic to cluster K, mark PROHIBITED on LSB , perform forced re-routing, start T11(K), and start using LSC to switch messages to K. EAGLE will mark K RESTRICTED on LSC for all members of K except FPC X . When T11 expires, send TFR response method for all members of K except FPC X .
7	SSP1 sends an MSU with DPC=Y	EAGLE will respond with TFR(Y) to SSP1 . MSU will be routed on LSC .
8	SSP1 sends an MSU with DPC=X	EAGLE will route MSU to SSP-X using LSE .
9	LSB recovers	EAGLE will stop using LSC to send traffic to cluster K, performs controlling rerouting on K, and mark cluster K as ALLOWED on LSB , starts routing traffic to cluster K via LSB .
10	SSP sends a route set test (RSR) concerning Y to EAGLE	EAGLE responds with a TFA(Y).
11	LSC fails.	EAGLE will stop using LSC to send traffic to cluster K or FPC X and mark K and FPC X PROHIBITED on LSC .
12	LSC recovers.	EAGLE will mark cluster K and FPC X ALLOWED on LSC .
13	LSE fails.	EAGLE will stop using LSE to send traffic to SSP-X , marks PROHIBITED on LSE , perform forced rerouting, start T11(X), send preventive TFP(X) to STP-B and start using LSB to switch messages to FPC X . EAGLE will mark FPC X RESTRICTED on LSB . When T11 expires and broadcast TFR(X) to SSP1 and STP-A .
14	SSP1 sends an MSU with DPC=SSP-Y	EAGLE will route MSU to SSP-Y using LSB .
15	SSP1 sends an MSU with DPC=SSP-X	EAGLE will respond with a TFR(X) to SSP1 . MSU will be routed to SSP-X using LSB .

Table 4-28 (Cont.) Nested Cluster Routing Example

No	Event	Action
16	LSE recovers.	EAGLE will stop using LSB to send traffic to SSP-X, perform controlling rerouting on FPC X and mark FPC X as ALLOWED on LSE, start routing traffic to FPC X via LSE. EAGLE broadcast TFA(X) to SSP1, STP-A, and STP-B.

Route Table for Nested Cluster K (5-5-*)

5-5-* LSB, RC=10

5-5-* LSC, RC=20

Route Table for FPC Member P (5-5-1)

5-5-1 LSE, RC=10

5-5-1 LSC, RC=20

Route Table for FPC Member Q (5-5-5)

5-5-5 LSE, RC=10

5-5-5 LSC, RC=20

4.113.4 Upgrade Considerations

The new software accommodates the old database during the upgrade. The new fields for the existing tables, such as the **NCR** bit in the feature table, defaults to 0 (**OFF**), and the **NCAI** parameter in the destination table defaults to 0 (**NO**).

Use the `rtrv-dstn` command to verify the status of the **NCAI** parameter (it should display `ncai = no` for existing cluster destinations). To activate the Nested **Cluster** Feature, the software release must contain the **CRMD** feature (non-nested cluster management).

4.114 Network Conversion Grouping Time Enhancement (Release 46.0)

Grouping link-based cards by Application GPL creates multiple groupings. The Network Conversion Grouping Time Enhancement feature allows grouping based on the Flash GPLs of the link-based cards.

4.115 Network Routing (Release 26.0)

Overview

Network routing allows the user to provision a single routeset that will be used for all **MSUs** destined to members of that network. The advantages of network routing are:

- reduces the number of entries in the route table
- allows routing to members of a network without having to add those members to the route table

An **EAGLE** user can connect to a remote network by provisioning a single route table element. As the remote network grows, the **EAGLE** user does not have to add new route table entries for each new point code in the remote network.

4.115.1 Types of Routing Strategies Available

EAGLE currently allows a user to provision two types of routing strategies:

- full point code routing
- network/cluster routing (also called cluster routing)

This feature allows the user to provision a third type of routing strategy:

- network routing

It is possible to provision full point code entries, cluster entries, and network entries for members of the same network. Any overlaps in the routing strategies are handled by a specific searching hierarchy.

Example

All of these route table entries can coexist:

1. 8-1-1 full point code entry
2. 8-1-* cluster entry
3. 8-*-* network entry

The searching hierarchy will try to match against a full point code entry first, followed by a cluster entry, and finally a network entry. In the preceding example, when **EAGLE** routes an **MSU** destined for 8-1-1, it uses the full point code entry; when **EAGLE** routes an **MSU** destined for 8-1-2 it uses the cluster entry; and when **EAGLE** routes an **MSU** destined for 8-2-2, it uses the network entry.

4.115.2 Applications

Network routing is very useful when the destination node is located far from the source node. The reliability of network routing increases when the destination is further away. As shown in the following figure, routing from network A is more reliable to nodes in network C than to nodes in network B.

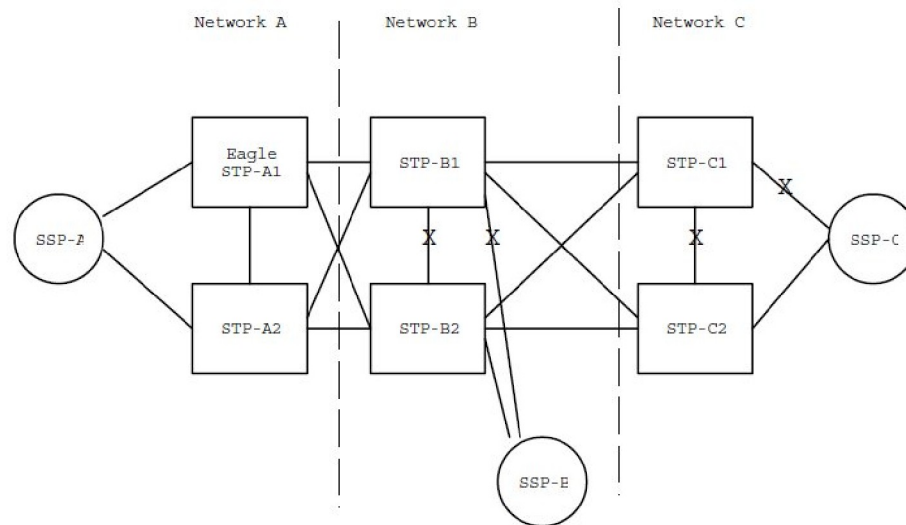
Figure 4-32 Example of Network Routing Reliability

If the **STPs** in Network A use network routing for Network C, Network A can still route traffic to **SSP-C**, even if two linksets fail. In this example, one of the A-linksets to **SSP-C** and the C-linkset between **STP-C1** and **STP-C2** fail. In this case, the **EAGLE** in Network A will continue to route half its traffic to **STP-B1**, and half to **STP-B2**. **STP-B1** and **STP-B2** (which do not use network routing) will route all traffic for **SSP-C** through **STP-C2**.

If the **STPs** in Network A use network routing for Network B, traffic going to **SSP-B** may be lost if two linksets fail. In this example, one of the A-linksets to **SSP-B** and the C-linkset between **STP-B1** and **STP-B2** fail. In this case, the **EAGLE** in Network A will continue to route half its traffic to **STP-B1**, and half to **STP-B2**. Traffic for **SSP-B** routed through **STP-B1** will be discarded, resulting in message loss.

4.115.3 MTP Requirements

Routing

In the following discussion, refer to the following figure:

Figure 4-33 Generic Network

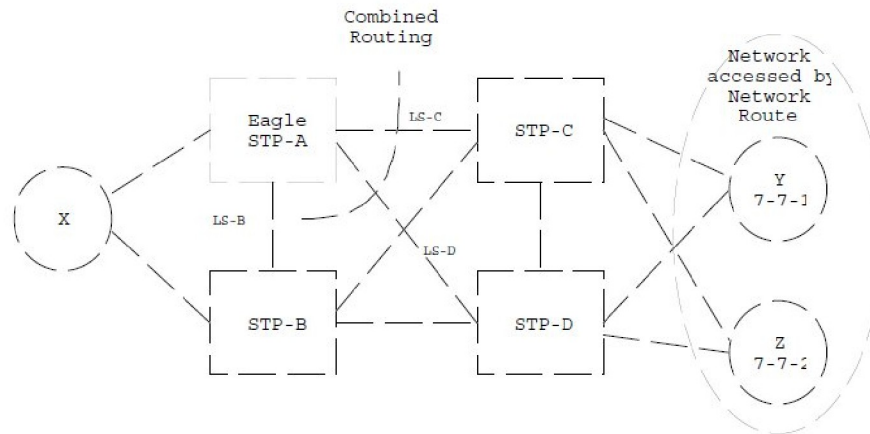

Route Availability

A route is one path to a destination. A routeset is a list of paths to a destination. **Route** availability consists of two parts:

1. local availability, and
2. remote availability

Remote availability is affected by **TFx** network management messages. Local availability is affected by linkset failures and recovers. **TFx** messages do not affect point codes accessed by network route entries. Therefore, for network route entries, route availability consists of only local availability. The highest priority linkset available for traffic will be used for routing **MSUs** regardless of the remote availability of that route.

Figure 4-34 Potential Routing Network Failure

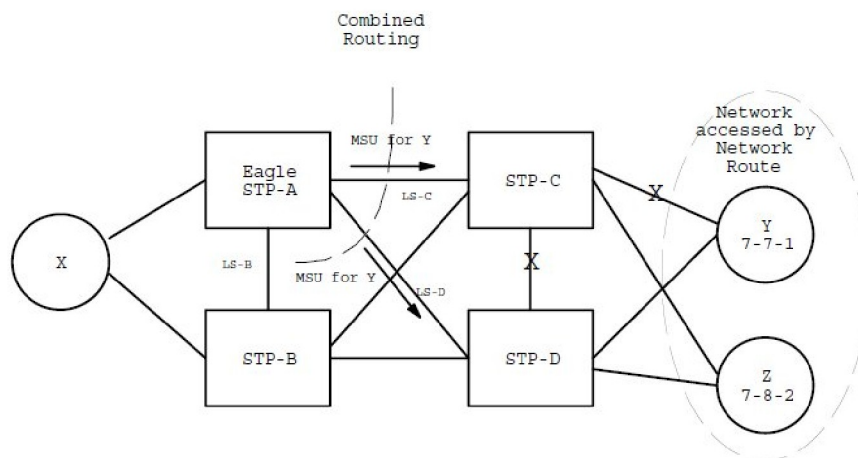

In the example in the following figure, linksets **LS-C** and **LS-D** form a combined route to network route 7-*. Because 7-*. is a network route, **EAGLE** will always consider

the non-adjacent status of the routes to be allowed. In the example shown, **EAGLE** routes traffic destined to 7-7-1 over **LS-C** and **LS-D**. **EAGLE** will ignore **TFPs** concerning 7-7-1 or **TCPs** concerning 7-7-*

Point Code Availability

A point code that is accessed by a network route entry is considered available if there is any linkset in the routeset that is available for traffic.

Routing MSUs

MTP message routing will search the routing table up to 3 times to find a routing entry for the received **MSU**.

The search order is:

1. a full point code match
2. a network/cluster match
3. a network match

Route Management

Congestion

Local Link Congestion

This feature has no impact on the generation of **TFC** messages. A **TFC** will be generated concerning point code X-Y-Z, even if X-Y-Z is routed using a network route entry.

Remote Congestion

Because **EAGLE** has global title capabilities, it is possible that a **TFC** is received by **EAGLE** concerning a point code that is accessed by a network route entry. Network route entries will not be affected by **TFC** messages.

Transfer Messages (TFP, TCP, TFR, TCR, TFA, and TCA)

Broadcast Transfer Messages

EAGLE will not broadcast **TFx** messages for network route entries.

Response Method Transfer Messages

EAGLE will send response method **TFx** messages for network routes as follows:

- Prohibited Network Routes

If **EAGLE** receives an **MSU** that is accessed by a network route entry, and that network route is prohibited, **EAGLE** will send a response method **TFP** or **TCP** message, as follows:

- If there is a full point code defined in the same cluster as the **MSU** (e.g. 8-*-1 and 8-1-1 are defined in **EAGLE**'s routing table, and **MSU** is destined for 8-1-2), **EAGLE** will send a **TFP** with Concerned **PC** set to the **MSU**'s **DPC**.
- Otherwise, **EAGLE** will send a **TCP** with Concerned **PC** set to the cluster of the **MSU**'s **DPC**.

EAGLE will pace response method **TCPs** or **TFPs** sent to 1 per link per T8 per network route.

For example, in figure [Figure 4-34](#), the network route for 7-*. becomes Prohibited due to the failure of **LS-B**, **LS-C**, and **LS-D**. When **EAGLE** receives an **MSU** from X destined for 7-7-1, **EAGLE** will send a response method **TCP** concerning 7-7-*. When **EAGLE** receives an **MSU** from X destined for 7-8-2, **EAGLE** will send a response method **TCP** concerning 7-8-*.

- **Danger of Circular Routing**

If **EAGLE** receives an **MSU** that is accessed by a network route entry, and **EAGLE** detects danger of circular routing (see [G-Port MNP Circular Route Prevention \(Release 28.1\)](#) for an explanation of circular routing dangers), **EAGLE** will send a response method **TFP** or **TCP** message, as follows:

- If there is a full point code defined in the same cluster as the **MSU** (e.g. 8-*. and 8-1-1 are defined in **EAGLE**'s routing table, and **MSU** is destined for 8-1-2), **EAGLE** will send a **TFP** with Concerned **PC** set to the **MSU**'s **DPC**.
- Otherwise, **EAGLE** will send a **TCP** with Concerned **PC** set to the cluster of the **MSU**'s **DPC**.

EAGLE will pace response method **TCPs** sent to 1 **TCP** per link per T8 per network route.

For example, in figure [Figure 4-33](#), all linksets are available. If **EAGLE** receives an **MSU** from **STP-C** destined for 7-7-1, **EAGLE** will detect danger of circular routing, and send a response method **TCP** concerning 7-7-*. **EAGLE** will also discard the **MSU**.

- **Restricted Network Routes**

If **EAGLE** receives an **MSU** that is accessed by a network route entry, and that network route is **Restricted**, **EAGLE** will send a one time response method **TFR** or **TCR** message, as follows:

- If there is a full point code defined in the same cluster as the **MSU** (e.g. 8-*. and 8-1-1 are defined in **EAGLE**'s routing table, and **MSU** is destined for 8-1-2), **EAGLE** will send a **TFR** with Concerned **PC** set to the **MSU**'s **DPC**.
- Otherwise, **EAGLE** will send a **TCR** with Concerned **PC** set to the cluster of the **MSU**'s **DPC**.

For example, in the following figure, the network route for 7-*. becomes **Restricted** due to the failure of **LS-C**, and **LS-D**. When **EAGLE** receives an **MSU** from X destined for 7-7-1, **EAGLE** will send a response method **TCR** concerning 7-7-*, then route the **MSU** over **LS-B**. When **EAGLE** next receives an **MSU** from X destined for 7-8-2, **EAGLE** will not respond, and will route the **MSU** over **LS-B**.

Reception of Transfer Messages

EAGLE will not apply received Transfer messages to a network route.

For example, in the following figure, if **EAGLE** receives a **TFP** concerning 7-7-1, it will have no effect on the routing status of 7-*. **EAGLE** will continue to send **MSUs** destined to 7-*. , including **MSUs** destined to 7-7-1, on **LS-C**.

As another example, if **EAGLE** receives a **TCP** concerning 7-8-*, it will have no effect on the routing status of 7-*. **EAGLE** will continue to send **MSUs** destined to 7-*. , including **MSUs** destined to 7-8-2, on **LS-C**.

Route Set Test

The **MTP** routeset test application will be able to handle the reception of full point code **RSx** and cluster **RCx** messages that apply to network route entries.

Reception of an RSx Message

If a route set test (**RSP** or **RSR**) is received, a full point code reply (**TFx**) is generated.

The responses to **RSP/RSR** will be modified according to the following table .

Note that the searching hierarchy applies.

Table 4-29 Reception of an RSx Message

Concerned point code is:	Result
Found by a full point code match	No change to existing rules.
Found by a cluster match	No change to existing rules.
Found by a network match	Send a TFx message based on the current routeset status. <ul style="list-style-type: none"> • Send a TFP if danger of circular routing. Otherwise: <ul style="list-style-type: none"> • Send a TFA if network route is Allowed • Send a TFR if network route is Restricted. • Send a TFP if network route is Prohibited.
Not found	No change to existing rules. Send a TFP.

Reception of an RCx Message

If a routeset cluster test (**RCP** or **RCR**) is received, a cluster reply (**TCx**) is generated. The responses to **RCP/RCR** will be modified according to the following table. Note that the searching hierarchy applies.

Table 4-30 Reception of an RCx Message

Concerned point code is:	Result
Found by a cluster match	No change to existing rules.
Found by a network match	Send a TCx message based on the current routeset status. <ul style="list-style-type: none"> • Send a TCP if danger of circular routing. Otherwise: <ul style="list-style-type: none"> • Send a TCA if network route is Allowed • Send a TCR if network route is Restricted • Send a TCP if network route is Prohibited.
Not found	No change to existing rules. Send a TCP.

4.116 Network Security Enhancements (Release 29.0)

Overview

The Network Security Enhancements feature enhances the **EAGLE's** network security by discarding messages that should not be received by the **EAGLE**. This feature is designed to

STP B should have issued a **TFP** for **SSP #1**. However, if the customer provisioned a route to **SSP#1** as shown by **MSU #1**, traffic would still be going to **SSP #1** through **STP B**. **STP D** should be using **D link-LSN 3** to route traffic to **SSP #1**.

It should be noted that messages following **MSU #1** call flow could be 2 possible types.

- **MTP** routed messages- these would **NOT** be blocked as the **OPC** in the routing label would be equal to **SSP #2**
- **GTT** routed messages/Messages Originated by **STP B**-these would be blocked as the **OPC** in the routing label would be the **OPC** of **STP B**.

Therefore, if **STP A** has the **SECMTPMATE** option active, **STP A** will discard messages received over any link other than **LSN 4** whose **OPC** is equal to the True, Secondary, or Capability point code of **STP B**. It should again be noted that this option enforces a standard network configuration rule that may not apply to all customers.

SECMTPSID Option

An example of the **SECMTPSID** option is shown by the flow of **MSU #2** in the following figure. Unauthorized **Network Element #1** potentially can flood and or send harmful bogus **SS7** messages over **LSN 10** that appear to have been generated by **STP A** by sending various messages with the **OPC =STP A**. This is obviously an undesirable situation and should not be allowed. The **EAGLE** should not receive a message with its own **OPC**, unless the message is a result of a circular route test or is an **SLTM** when the far end is in loopback.

Figure 4-36 SECMTPSID Option Diagram

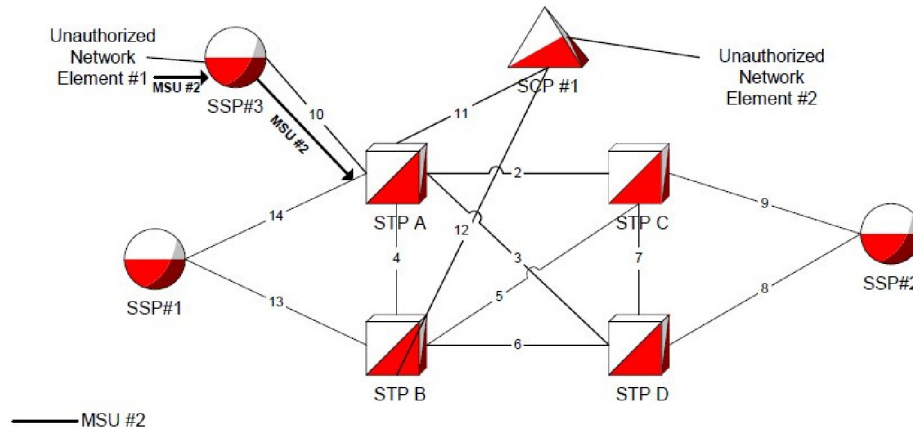

Therefore, assuming **STP A** has the **SECMTPSID** option active, it will discard all received messages with an Origination **Point Code (OPC)** equal to its True, Secondary or **Capability Point Code(s)**, unless all the following criteria are met:

- The **EAGLE's MTP Circular Route** Detection Mechanism sent the message with an **OPC** equal to the **EAGLE's TPC/SPC** (i.e. message is an **RCT** message with a priority of 3).

OR

- Message is an **SLTM** and has an **OPC** equal to the **EAGLE's TPC** or **SPC**.

 **Note:**

SLTMs with an **OPC** equal to the **EAGLE's TPC/SPC** can be received when the far end is in a physical loopback, and the **EAGLE** will transmit an **SLTM** (e.g. via TST-SLK). Instead of receiving an **SLTA** from the far end with an **OPC** of the far end, the **EAGLE's SLTM** message will be returned. Without this check, **SLTMs** would be discarded.

MTP Network Management Message OPC Verification (SECMTPSNM)

SECMTPSNM option functionality is based upon the assertion that the **EAGLE** should not receive an **MTP** network management message unless:

Rule #1 - The **OPC** is an adjacent point code

Rule #2 - The **EAGLE** has a route to the **OPC** of the **MTP** network management message on the linkset which the message was received.

Rule #3 - The **EAGLE** has a route to the destination field in the message (if applicable to the concerned message) on the linkset which the message was received.

For all link types, the following additions/exceptions apply:

- Rule #3 would not apply to **RSM** messages.
- Rule #1 would not apply to **UPU**, **TFC** and **RCT** messages.

SECMTPSNM Option for A and E Links

Assuming **STP A** has the **SECMTPSNM** option active and an **MTP** network management message is received over an A link, **STP A** will only allow the message to itself when all the criteria are met. Refer to the following figure.

Figure 4-37 SECMTPSNM A link Option Diagram

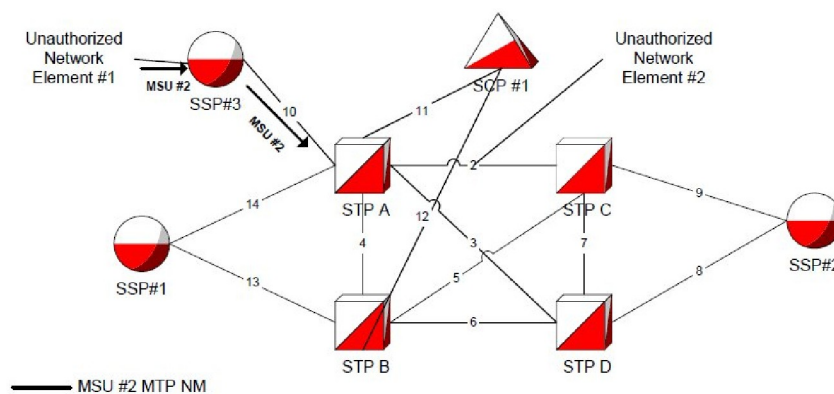

- As shown by **MSU #2**, **Unauthorized Network Element #1** can send a **TFP** with a destination field = **SSP#1**, an **OPC=SSP #3**, and a **DPC=STP A** to **STP A**. It would pass Rule #1, pass Rule #2 and fail Rule #3.
- Example of why **RSM** messages are excluded from Rule #3: If **LSN 14** and **LSN 13** were to fail, **STP A** would send a **TFP** to **SSP#3** concerning **SSP#1**. **SSP #3**

would subsequently send a **RSPs** to **STP A** concerning **SSP #1** via **LSN 10**. If Rule #3 applied to the **RSP**, it would be discarded, since **STP A** does not have a route to **SSP #1** on **LSN 10**.

SECMTPSNM Option for B-C-D Links

Assuming the **STP C** has the **SECMTPSNM** option active, it will allow all **MTP** network management messages received over B-C-D links when criteria listed in 2.2 are met. Refer to the following figure.

Figure 4-38 SECMTPSNM B-C-D link Option Diagram

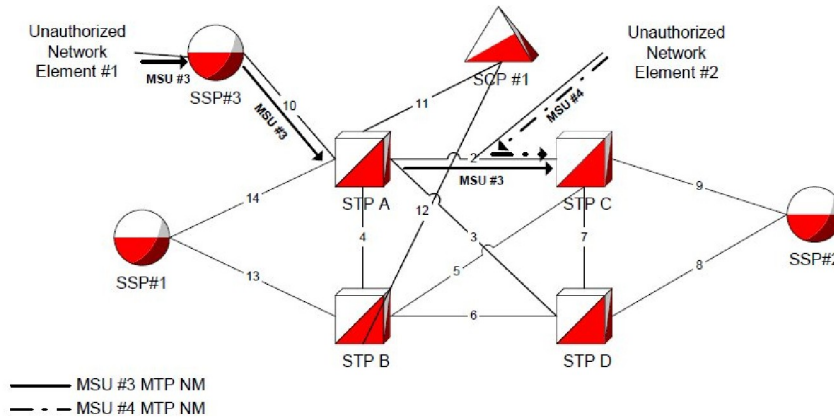

- As shown by **MSU #3**, **Unauthorized Network Element #1** can send a **TFP** with a destination field = **SSP#2**, an **OPC=SSP #3**, and a **DPC=STP C**. **STP A** would **MTP** route this message to **STP C** over **LSN 2**. **STP C** would receive this message and it would fail Rule #1, pass Rule #2 and fail Rule #3.
- Example of why **RSM** messages are excluded from Rule #3- **MSU #4**-if **Unauthorized Network Element #2** injected **RSP** messages with an **OPC=SSP#1**, **DPC=STP C** and a destination field= **SSP#2**. **STP C** would reject the message since **SSP#1** is a non-adjacent node and would subsequently fail Rule #1. Furthermore, if **Unauthorized Network Element #2** injected **RSP** messages with an **OPC=STP A**, **DPC=STP C**, and a destination field= **SSP#2**, **STP C** would **NOT** reject this message since Rules 1 and 2 would be passed.

SCMG AFTPC Verification (SECSCCPSCMG)

SECMTPSNM option functionality is based upon the assertion that the **EAGLE** should not receive a **SCCP** network management message unless:

1. The **EAGLE** has a route to the **OPC** of the **SCMG** message on the linkset, on which the message was received.
2. The **EAGLE** has a route to the **Affected Point Code** in the message on the linkset on which the message was received.

The **Affected Point Code** (industry term) and the **Concerned Point Code** (**EAGLE** term) are synonymous. This option will only apply to **SSP** and **SOR** messages. This feature will not affect the following messages: **SSA**, **SST**, **SOG**, **SBR**, **SNR** and **SRT**. Refer to the following figure.

Figure 4-39 SECSCCPSCMG Option Diagram

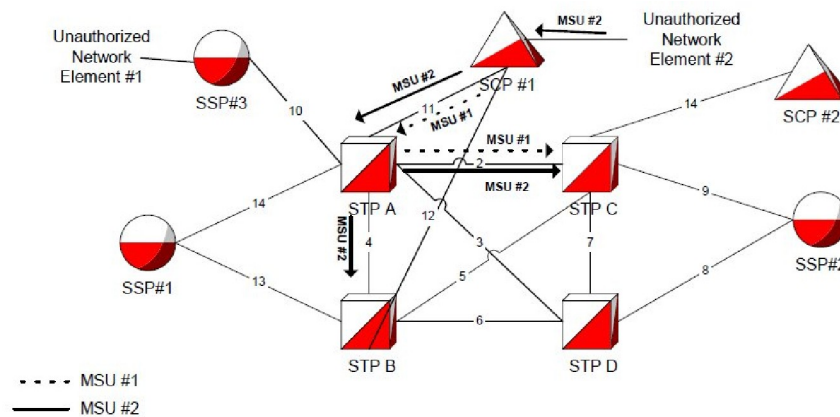

Normal operation for **SCMG** messages (e.g. **SSP**) would be for **SCP#1** to send an **SSP** to **STPA**. **STP A** will look in the Concerned **Point Code** table and broadcast **SSPs** to point codes listed in that table with an **OPC =STPA**. The **SSPs** that are broadcasted will have an **OPC= STP A** and an **AFTPC = SCP#1**.

As shown by **MSU #1** (normal operation), if **SCP #1** sends an **SSP** to **STP A** (**MSU #1**), **STPA** will look in the Concerned **Point Code** table to see which point codes should receive a broadcast **SSP** concerning **SCP#1**. Assuming **STP B** and **STP C** are in the **CSPC** table, **SSPs** are broadcast to **STP B** and **STP C** (**MSU #2**).

Assuming **STP C** has the **SECSCCPSCMG** option active, it will discard any **SSP** or **SOR** message received on a linkset for which the **EAGLE** does not have a route to the **AFTPC** on that linkset. This is similar in nature to the **SECMTPNM** option except the **AFTPC** field in the **SCMG** is checked, instead of the destination field in the **MTP** network management messages, and ensures that an **SSP** or **SOR** message is received over a linkset that **STP C** has a route for.

As shown by **MSU #2**, if Unauthorized **Network Element #2** attempts to send **SSPs** with an **AFTPC** of **SCP #2** and a **DPC** of **STP C** via **LSN 11**, **STP C** will receive the **SSP MTP** routed from **STP A** over **LSN 2** with the **OPC=SCP #2**, **DPC=STP C**, and **AFTPC=SCP #2**. Since **STP C** does not have a route to **SCP#2** over **LSN 2**, the message will be discarded.

Hardware Requirements

No new hardware is needed to support this feature.

Limitations

This feature will not be implemented on **GX25** cards.

It will be assumed that the **CPC** of the Mate **STP** will match the **CPC** of the **EAGLE**. This feature also assumes that routing is provisioned symmetrically between any two points (i.e., if a valid **NM** message is received on a link set, there should be a corresponding route provisioned to the **OPC** and destination over that incoming link set; e.g., if A can route to B through C, B should also be able to route to A through C).

4.117 Network Surveillance Enhancements (Release 28.0)

Description

The Network Surveillance Enhancement feature adds a new terminal type to the **EAGLE** system. This terminal type, the Management Terminal (**MGMT**), provides a machine-to-machine messaging interface between the **EAGLE** and network Operations Support Systems, **OSS**. This feature lets the **EAGLE** integrate more smoothly with most network monitoring devices.

Hardware Requirements

No new hardware is required to support this feature.

4.118 New Control Shelf Backplane (Release 23.0)

A new backplane for the control shelf has been introduced in Release 23.0 with these changes:

- The maintenance bus has been removed from the backplane.
- The backplane has been redesigned to distribute the clock signals for the high-speed **ATM** signaling links at 1.544 Mb/s.
- Two serial port connections (**DB-15** connectors) have been added to the control shelf backplane, one providing emergency access to the standby **MASP**, the other providing a connection to the **TDM** for critical indications.
- The control shelf backplane now contains four -48VDC power and ground connections (**DB-26** connectors). Two of these connectors are labeled Primary A and B and are connected to the fuse and alarm panel. The other two are labeled Secondary A and B and are connected to another power source, allowing the **EAGLE** to remain in service when replacing the fuse and alarm panel.
- All **EAGLE** shelves have a binary address to identify the shelf to the system. The control shelf backplane address is permanently configured and cannot be changed. This allows only one control shelf in the **EAGLE**. The shelf address has been expanded from four bits to six bits, increasing the maximum number of addressable card slots from 250, or 500 signaling links, to a theoretical limit of 1018, or 2036 signaling links. The actual number of addressable card slots is limited by the system software and the hardware configuration of the **EAGLE**. In Release 23.0, the actual number of addressable card slots is 378, or 756 signaling links, but is limited by the system software to 250 cards, or 500 signaling links.
- To allow the **TDMs** to determine which version of the control shelf backplane they are connected to, the control shelf backplane uses pins A49, A50, and A52 on connectors P2 and P4 to send a binary signal to the **TDMs**. On previous backplanes, these pins were left unconnected, creating a binary signal of 111. On this backplane, the least significant bit of the signal, pin A49, is connected to ground, creating a binary signal of 110. This signal corresponds to this version of the control shelf backplane.

4.119 New Hardware (Release 23.1)

Description

Release 23.1 introduces improvements to these cards in the **EAGLE**.

- **TDM**
- **MDAL**
- **IPMX**
- E486 main assembly for the **ASM**, **ACM**, **LIM**, and **MCAP** card
- E586 main assembly for the **TSM-256** and **MCAP-256** card

It also introduces a new card into the **EAGLE**, the integrated **LIM-AINF**.

The electrostatic discharge (**ESD**) clips on these cards have been redesigned so they do not bend easily, making the insertion and extraction of the cards easier.

Each card has been redesigned so that the tooling holes and holes used for mechanical attachment cannot be used as functional plated-through holes and provide electrical connections between the conductor layers of the card.

The nut and washer assembly used for attaching the faceplate to each card has been replaced with **PEM** nuts, reducing the labor required to assemble the card.

A diode has been added to the -48V return path to prevent the **TDM** from being powered by the other **TDM** through the connections for the fuse alarms.

The **BITS** clock recovery circuit on the **TDM** has been improved to tolerate more noise on the clock input and make the **BITS** clock recovery circuit more stable.

To ensure that the **TDM LED** comes on when it is supposed to, the controlling resistor for the **LED** has been changed from 10K Ohms to 1K Ohms.

These design modifications do not have any impact on the software functionality of these cards.

Integrated LIM-AINF Card

A new card is being introduced to the **EAGLE**, the integrated **LIM-AINF** card, P/N 870-1484-xx. The integrated **LIM-AINF** card contains all the functionality of the **LIM-AINF** card, P/N 870-1014-xx, and is contained on one board. The **AINF** applique is not used or required for the integrated **LIM-AINF** card. No other applique can be used with this card. It can only serve as a **LIM**. The integrated **LIM-AINF** contains the three **LIM** interfaces, **DS0**, **OCU**, and **V.35** and uses the system software to select the interface, the same as on the old **LIM-AINF** card.

4.120 New Hardware (Release 26.05)

Multi-Purpose Server (MPS)

The **MPS** hardware system is being deployed in conjunction with the **EAGLE** STP Database Service Module (**DSM**) subsystem for both the **G-Flex** C7 Relay and Intelligent Network Application Part (**INAP**)-based Number Portability features. See [G-](#)

[Flex C7 Relay \(Release 26.2\)](#) and [INAP-based Number Portability \(INP\) \(Release 26.05\)](#) for discussion of these features.

The **MPS** hardware system includes the **MPS**, supporting **Local Area Network (LAN)** devices and associated peripheral units.

Refer to the **NSD Hardware Manual** for current information on the **MPS** hardware.

4.121 Non-ANSI Point Code Support (Release 20.0)

The **EAGLE** supports the use of the network identifier of “0” to accommodate networks outside of the **ANSI** network with nonconventional point codes. This network identifier can also be used as a test point code in some applications within the U.S.

4.122 Non-Generation of Duplicate SEAS Autonomous Messages (Release 22.0)

This feature allows only one copy of a **SEAS** autonomous message to be sent to the first available **SEAS** port. This prevents duplicate **SEAS** autonomous message from being sent to the **SEAS** ports.

4.123 Non-SCCP/ISUP Routing (IP⁷ Releases 1.0, 2.0)

This feature, which was available only in a laboratory environment in release 1.0, allows **SS7** nodes to exchange non-**ISUP** and non-**SCCP** protocol messages with one or more **TCP/IP**-based devices residing on an **IP** network. The following figure shows a network example for this feature. The **IP⁷** Secure Gateway node maps the destination point code and service indicator (non-**ISUP**, non-**SCCP**) to a **TCP/IP** address and port.

Figure 4-40 Non SCCP/ISUP Routing

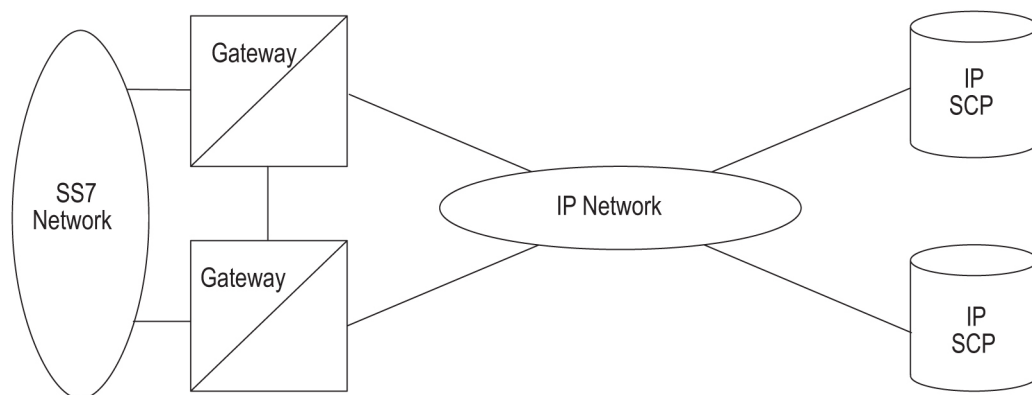

4.124 Notification of Congestion Level Increase (Release 22.0)

When the congestion or discard level on a signaling link increases from one Elevel to the next, the **EAGLE** issues one of these **UIMs** to the **EAGLE** terminals.

UIMs

UIM 264—REPT-LINK-CGST: congestion level 0 to 1

UIM 265—REPT-LINK-CGST: congestion level 1 to 2

UIM 266—REPT-LINK-CGST: congestion level 2 to 3

UIM 270—REPT-LINK-CGST: discard level 0 to 1

UIM 271—REPT-LINK-CGST: discard level 1 to 2

UIM 272—REPT-LINK-CGST: discard level 2 to 3

In release 22.0, when one of these **UIMs** is issued, the **EAGLE** sends the **SEAS** message **REPT-LINK-CGST** to the **SEAS** interface.

The threshold of each congestion or discard level is included in the **REPT-LINK-CGST** message and is defined as the number of **MSUs** being transmitted on the signaling link or the number of **MSUs** being discarded because of the congestion.

4.125 Notification of Inability to Perform a Global Title Translation (Release 22.0)

Whenever the **EAGLE** is unable to perform a **GTT** due to administration table problems, and an **MSU** is discarded, the **EAGLE** issues one of these **UIMs**.

UIMs

UIM 1043 — SCCP did not route - bad translation

UIM 1046 — SCCP did not route - DPC not in MAP tbl

UIM 1049 — SCCP did not route - SS not in MAP tbl

In Release 22.0, when any of these **UIMs** are issued, the **EAGLE** sends the **REPT-NOTRNS** message to the **SEAS** interface. To control the number of **REPT-NOTRNS** messages being sent to the **SEAS** interface, the **REPT-NOTRNS** message is only sent if less than 10 previous **REPT-NOTRNS** messages have been sent during a 5 minute period. If 10 **REPT-NOTRNS** have already been sent during the 5 minute period, no **REPT-NOTRNS** messages are sent until the 5 minute period has expired. When this 5 minute period expires, a new 5 minute begins and the **EAGLE** resumes sending **REPT-NOTRNS** messages.

4.126 Notification of Link Set Outage (Release 22.0)

When all signaling links in a linkset become unavailable because of multiple signaling link failures or processor outages, the **EAGLE** issues **UIM 318 - REPT-LKSTO: Link set prohibited**.

In Release 22.0, when **UIM 318** is issued, the **EAGLE** sends the **SEAS** message **REPT-LKSTO** to the **SEAS** interface. Included in the **REPT-LKSTO** message is the number of signaling links that have failed (the primary state of the signaling links is **OOS-MT**) and the number of signaling links that have been inhibited (the

4.127 Notification of Link Set Recovery (Release 22.0)

When the linkset outage condition, reported with **UIM 318** or the **SEAS REPT-LKSTO** message, has been corrected, the **EAGLE** issues **UIM 317 - RCVRY-LKSTO: Link set allowed**.

In Release 22.0, when **UIM 317** is issued, the **EAGLE** sends the **SEAS** message **RCVRY-LKSTO** to the **SEAS** interface. Included in the **RCVRY-LKSTO** message is the number of signaling links in the linkset that are back in service.

4.128 Notification of Locally Initiated Database Copy (Release 22.0)

This feature requires the **EAGLE** to send the **REPT-DBCPY** message to the **SEAS** interface any time the **EAGLE** database is backed up or restored with the **EAGLE** command `chg-db`. This message is sent regardless of whether the `chg-db` command was entered correctly or completed successfully.

The following table defines the indicators used to show which version of the database the **REPT-DBCPY** message is reporting about.

Table 4-31 REPT-DBCPY Database Indicators

Database Indicator	SEAS Definition	EAGLE Definition
C	Current active version of the database	The database in the current partition of the fixed disk
P	Primary version of the database	The database in the backup partition of the fixed disk
X	Copy of the database on an external device	The copy of the database on a removable cartridge device

A completion code of **COMPLD** (completed **OK**) is sent to the **SEAS** interface when the `chg-db` command completes with no errors.

A completion code of **NSD** (not started) is sent to the **SEAS** interface when the `chg-db` command is rejected because of semantic errors.

A completion code of **ABTD** (aborted) is sent to the **SEAS** interface when the `chg-db` command fails during execution.

This message is not sent if the **EAGLE**'s `copy-tbl` or `copy-disk` commands are used to overwrite the active database.

4.129 Notification of MTP-Level Routing Error (Release 22.0)

When an **MSU** is discarded because the **EAGLE** has received the **MSU** with an undefined point code or an invalid **SIO**, these **UIMs** are issued.

UIMs**UIM 1004—MTP rcvd unknown DPC****UIM 1018—MTP rcvd invalid SIO**

In Release 22.0, when either of these **UIMs** are issued, the **EAGLE** sends the **REPT-MTPERR** message to the **SEAS** interface. To control the number of **REPT-MTPERR** messages being sent to the **SEAS** interface, the **REPT-MTPERR** message is only sent if less than 10 previous **REPT-MTPERR** messages have been sent during a 5 minute period. If 10 **REPT-MTPERR** have already been sent during the 5 minute period, no **REPT-MTPERR** messages are sent until the 5 minute period has expired. When this 5 minute period expires, a new 5 minute begins and the **EAGLE** resumes sending **REPT-MTPERR** messages.

4.130 Notification of Recovery from Link Congestion (Release 22.0)

When the congestion or discard level on a signaling link increases from one level to the next, the **EAGLE** issues one of these **UIMs** to the **EAGLE** terminals.

UIMs**UIM 267—RCVRY-LINK-CGST: congestion level 3 to 2****UIM 268—RCVRY-LINK-CGST: congestion level 2 to 1****UIM 269—RCVRY-LINK-CGST: congestion has cleared****UIM 273—RCVRY-LINK-CGST: discard level 3 to 2****UIM 274—RCVRY-LINK-CGST: discard level 2 to 1****UIM 275—RCVRY-LINK-CGST: discard has cleared**

In release 22.0, when one of these **UIMs** is issued, the **EAGLE** sends the **SEAS** message **RCVRY-LINK-CGST** to the **SEAS** interface.

The threshold of each congestion or discard level is included in the **RCVRY-LINK-CGST** message and is defined as the number of **MSUs** being transmitted on the signaling link or the number of **MSUs** being discarded because of the congestion.

4.131 NPP Conditioning Action Support for Extracting Variable Length Area Code from CgPN (Release 44.0)

Numbering Plan Processing (NPP) Conditioning Action support is added to extract area codes of different lengths from the Calling Party Number (CgPN). Conditioning Actions ACCGPN1 - ACCGPN8 are added to specify the length of Area Code to be extracted from the CgPN while processing the NPP service.

After stripping the Country Code from the CgPN, the Conditioning Action extracts the appropriate length of the area code from the CgPN. The area code token is then populated with the extracted digits.

The ACCGPN1 - ACCGPN8 Conditioning Actions are mutually exclusive with each other and with the existing ACCGPN Conditioning Action.

The logic used by the ACCGPNx Conditioning Actions is the same as that of the ACCGPN Conditioning Action. The only difference is that the length of area code to be extracted from the CgPN is not determined by the SCCOPTS:ACLEN, GSMSMSOPTS:MOSMSACLEN, or IS41SMSOPTS:MOSMSACLEN parameter. Instead, the digit suffixed 'X' for the ACCGPNX parameter is used to specify the length of the AC to be extracted. For example, Conditioning Action ACCGPN4 extracts an area code of 4 digits from the CgPN.

The ACCGPNx Conditioning Actions are supported by the TIF, TIF2, TIF3, IDPRCDPN, IDPRCDPN2, IDPRCDPN3, IDPRCDPN4, MOSMSGCDPN, and MOSMSICDPN NPP Services.

4.132 NPP Enhancements: More NPP Formatting Actions for the INP Routing service part of IDP Relay (Release 45.0)

The Prepaid IDP Query Relay feature (IDP Relay) is enhanced to allow the DRA digits in the IDP Connect Response message generated by the INPRTG Service Action to be formatted based on the NPP framework from the incoming message.

Five new Formatting Action (FA) lists are added to allow different combinations of digit formatting in the generated responses:

- DFLT—Digits are formatted using the TTROPTS:CDDRA and TTROPTS:CGDRA parameters
- FANE—Format digits when neither the SP nor the RN network entity is associated with the DN in the RTDB
- FANF—Format digits when the DN is not present in the RTDB
- FARN—Format digits when the RN network entity is associated with the DN in the RTDB
- FASP—Format digits when the SP network entity is associated with the DN in the RTDB

The `chg-npp-as` command is used to populate an FA list with Formatting Actions. The Formatting Actions that are added to the FA list are used in to format the digits in the response message.

For example, the command `chg-npp-as:asn=asn1:fa=cc,ac,grn,sn:fatype=fane` populates the FANE FA list with the the CC, AC, GRN, and SN Formatting Actions. These formatting actions are then used to "format digits when neither the SP nor the RN network entity is associated with the DN in the RTDB" as shown in the definition of the FANE FA list.

4.133 NPP Single Digit Wild Card Optionality (Release 44.0)

NPP Single Digit Wild Card (**SDWC**) Optionality allows the desired single digit wild card functionality to be selected by turning a new NPP Unlimited SDWC Characters feature (Part Number 893-0393-01) on or off.

If the NPP Unlimited SDWC Characters feature is turned on:

- An unlimited number of SDWC characters is allowed for each Numbering Plan Processor (**NPP**) service.
- A maximum of 3 SDWC characters is allowed in a Filter Prefix (**FPFX**) value.
- The SDWC characters must be within the first 6 digits (except the last digit) of the FPFX value.

If the NPP Unlimited SDWC Characters feature is turned off or is not enabled:

- A maximum of 25 SDWC characters is allowed for each NPP service.
- An unlimited number of SDWC characters is allowed in an FPFX value.
- The SDWC characters are allowed in any FPFX digit location except the last digit.

4.133.1 Feature Control Requirements

- FAK for Part Number 893-0393-01
- The feature cannot be turned on if any existing NPP service rules have more than 3 SDWCs specified for the FPFX value.
- The feature cannot be turned on if any existing NPP service rules have an SDWC specified after the sixth digit of the FPFX value.
- The feature cannot be turned off if an SDWC is specified for the FPFX value more than 25 times across all of the rules for an NPP service.
- A temporary FAK cannot be used to enable the feature.
- The feature can be turned on and off.

4.134 Number Pooling (Release 24.0)

Number pooling involves assigning a portion of an **NPA-NXX**, for example a thousands block (**NPA-NXX-X**), to a service provider (block holder) which is different from the **NPA-NXX** holder (the code holder). Before number pooling, numbers were assigned to service providers on an **NPA-NXX** basis. For smaller service providers needing fewer than 10,000 numbers, this method results in many unused, but reserved numbers. Number pooling is used to allow the allocation of numbers on a smaller block basis.

In the **EAGLE**, a number no longer owned by the **NPA-NXX** holder can be viewed the same as a number ported to a new service provider. Any or all of the numbers in a given **NPA-NXX-X** can be ported to the block holder by generating subscription versions with the block holder's data.

The subscription data in the **EAGLE** has been modified to show which of three **LNP** types have been assigned to the **LNP** subscription.

- **LSSP** – Local Service Provider Portability
- **LISP** – Local Intra-Service Provider Portability
- **POOL** – Pooled Block Number Port

In the **EAGLE**, the **LNP** subscriptions containing telephone numbers that are ported to an **NPA-NXX-X** block holder are designated with the **LNP** type of **POOL**. Telephone numbers that are ported before having the **LNP** type assigned to the telephone subscription are assigned the **LNP** type **NONE**.

The **LNP** type is not part of the subscription version data received from the **LSMS**, but must be assigned to the subscription data using either the `ent-lnp-sub` or the `chg-lnp-sub` commands.

4.135 Number Pooling/Efficient Data Representation (EDR) (Release 26.1)

Overview

Currently, the assignment of 10,000 (**NPA-NXX**) blocks of phone numbers to service providers for number portability results in large numbers of unused phone numbers in the **NPA-NXX** block, especially for smaller service providers. To conserve new **NPA-NXX** blocks of numbers and to provide more efficient use of existing **NPA-NXX** blocks, pooling of 1000 number blocks was mandated by **NANC**.

Number Pooling/**EDR** allows the **NPA-NXX** service provider holder (code holder) to assign a portion of an **NPA-NXX**, i.e. a thousand block (**NPA-NXX-X**), to another service provider (block holder). **EDR** allows this thousand block of numbers to be represented as a single record.

Currently, number pooling is implemented in the industry without **EDR**. This means that when the 1000 number blocks **TN's** are pooled (ported out from the code holder), the pool of 1000 numbers comes across the **NPAC/LSMS** interface as individual records (a 1000 **TN** port at one time). This can result in interface performance and database utilization problems.

Efficient Data Representation (**EDR**) was conceived so that pooled 1000 blocks of **TN's** could be managed as one subscription object. The numbers in a given **NPA-NXX-X** can be ported from the code holder to the block holder by generating subscription versions with the block holder's data. This type of port is designated with an **LNP** type of "**POOL**," which is maintained as part of the subscription version from the **SOA** to the **NPAC** to the **LSMS** and down to the **EAGLE**.

This feature is dependent upon the North American Numbering Council (**NANC**) 3.0 release, and the associated feature in **LSMS** 3.0.

End Office Perspective

Current switching mechanisms for number portability query and response have been modified to support Number Pooling/**EDR**. Default routing functionality is maintained.

Because 1000 blocks of **TNs** are pooled from the code holder to the block holder, special arrangements must be made, since the block holder may not have customers for all the 1000 **TNs** that were pooled.

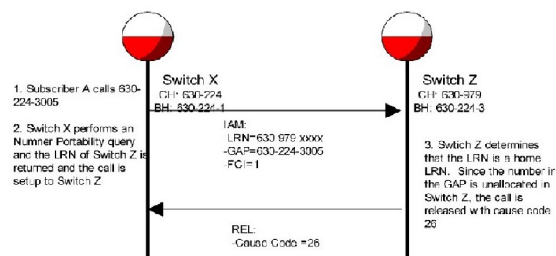
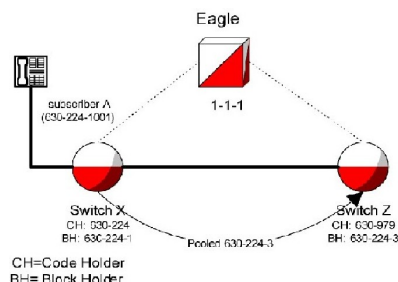

This event would cause both Switch X and Z service providers to think the call was misrouted, when indeed it was not.

To remedy this situation, a **NP-Reserved** marking is used on Switch Z to suppress code 26 and provide unallocated number treatment (for example, "You have reached a number that is not in use").

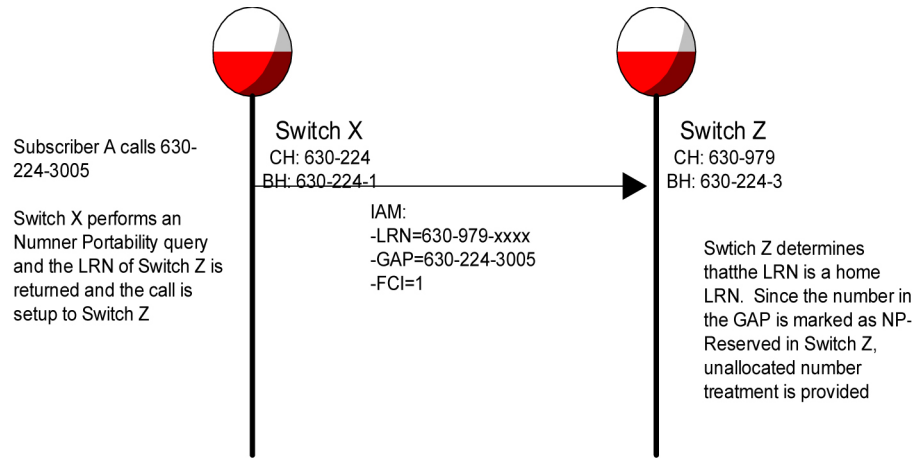

In this scenario, if 630-224-3005 were assigned to subscriber E, switch Z would find subscriber E in the **NPDB**, and route the call in Switch Z's network. If subscriber E subsequently ports to a new service Provider, Switch Y, the pooled block in Switch Z indicates that 630-224-3005 is ported to Switch Y, and normal **LRN** routing occurs for the call.

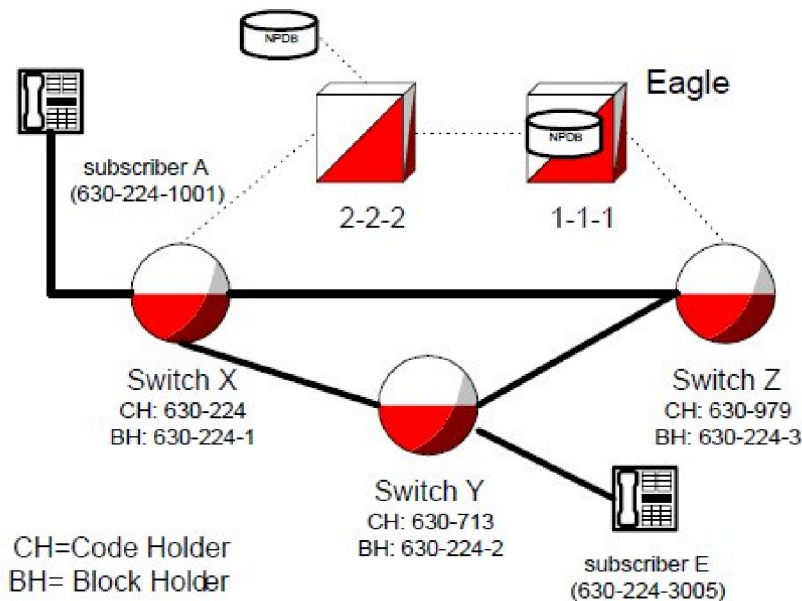

If there is a timing issue with subscription records being updated from the **NPAC** to each switch's **NPDB**, errors in routing can occur. For example, if the **NPDB** for Switch X is not updated due to equipment problems, a call from subscriber A to subscriber E would be routed by Switch X with the **LRN** received from its non-updated **NPDB**. Switch Z detects the **LRN** as a home **LRN**, and because the **GAP** is marked as **NP-Reserved** on the switch, Switch Z provides unallocated number treatment. Switch Z should have released the call with cause code 26.

To alleviate this timing issue, when subscriber E ports to Switch Y, the number from the **NPAC** can be marked as Ported Out. This marking in the preceding example will operate as follows:

When Switch Z receives the call with the home **LRN**, the number is marked as ported out at Switch X when subscriber E ports. Then, when Switch Z receives the call with the **GAP** parameter marked as Ported Out, Switch Z will correctly provide cause code 26 treatment.

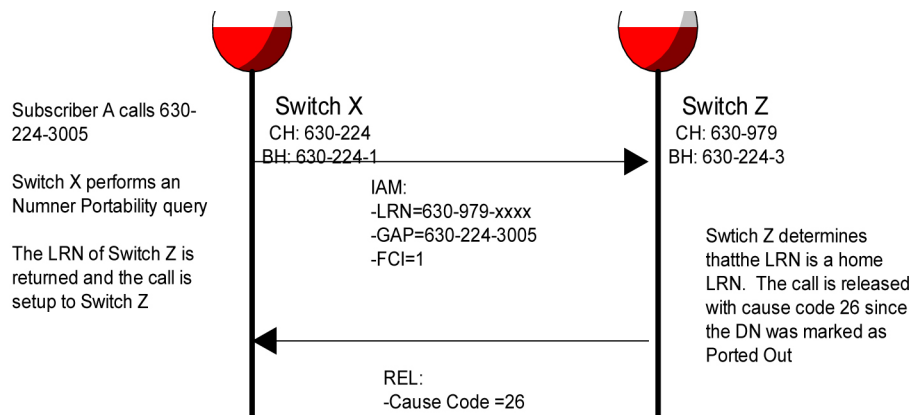

In addition, if subscriber E disconnects service, 630-224-3005 is "snapped back" to Switch Z. Typically, the Ported Out marking is removed, and the **NP** Reserved Marking is reinstated.

When an **NPA-NXX** is split, the pooled blocks of 1000 **TN**'s will have the same **NPA** after the split. This means that if area code 919 was split into 919 and 376 area codes, any pooled numbers (919-460-1xxx, 919-345-3xxx, etc) would have the same **NPA** (919) after the split.

EAGLE Perspective (LNP Database)

From the **EAGLE** perspective, Number Pooling/**EDR** can be viewed as another table lookup prior to defaulting to the default **GTT** data. Pooled ranges become an intermediate step in a **TN** lookup.

Figure 4-41 Database Lookup Hierarchy

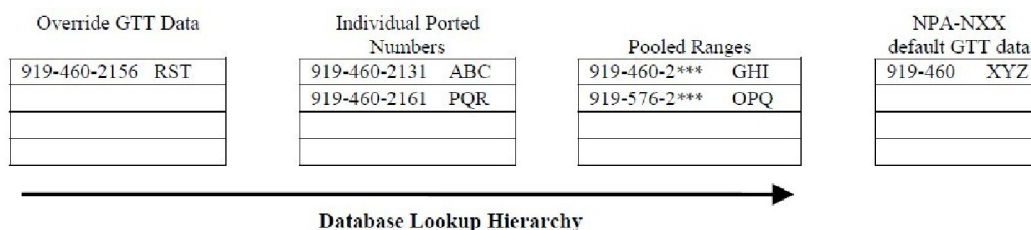

Upgrade Considerations

While no new upgrade requirements have been identified, note that the **EAGLE** must rely on **LSMS** to provision newly pooled objects, and remove individual subscription exceptions that are contained within the pooled block, in order to take advantage of the **EDR** capability. The **EAGLE** database update performance will depend on method that is used to do it. For High-speed bulk-load/reconcile, the **EAGLE** database will be updated at 200 **TPS** and additional time it takes to do the finish-edl process on the **EAGLE**. If slow-speed reconcile is used, **EAGLE** will be updated at 2 **TPS**.

Limitations

The **EAGLE** must be upgraded to support **EDR** data records prior to upgrading the **OAP**. The **OAP** must be upgraded to support **EDR** data records prior to upgrading the **LSMS**.

4.136 OAP Upgrade Enhancement (Release 27.2)

The **OAP** is now self-configuring, for the purpose of determining the **OAP** operating mode.

4.137 OCTRETRN in 30-Minute Measurements Reports (Release 31.4)

The **OCTRETRN** register is added to the output of the **COMP-LINK** report for **EAGLE** for both the Measurements Platform and **OAM** generated measurements.

The **OCTRETRN** (octets retransmitted) peg is available on 30 minute intervals. previously, it was only available on 24 hour interval.

4.138 Online Cartridge Formatting (Release 20.0)

The **EAGLE** supports online formatting of the removable cartridge. The removable cartridge can be formatted to hold either system data (the database and the **GPLs**) or measurements data.

4.139 OpCode Options Added to the ECAP Configuration Menu (ECAP 40.1)

The addition of the *Allow/Filter OpCodes* options to the ECAP Configuration menu allows control over the Op Codes included in the measurements data that ECAP sends to the Aggregator from the ECAP.

The *OpCode Filtration Mode* can be set to either *AllowAll* or *DiscardAll*. The *AllowAll* mode is the default mode for ECAP and allows all OpCodes received by ECAP to be sent to the Aggregator. The *DiscardAll* mode discards all OpCodes received by ECAP and sends none to the Aggregator. The defaults for each mode can be modified using other filtrations options.

For more information about the options used to filter the OpCodes, refer to [Table 4-32](#).

Table 4-32 Allow/Filter OpCodes Menu Options

Menu Option	Description	Range of Values
Allow / Filter OpCodes	Displays a set of options that allows control over the set of opcodes that are included in the measurements data.	[1..5, E]

Table 4-32 (Cont.) Allow/Filter OpCodes Menu Options

Menu Option	Description	Range of Values
OpCode Filtration Mode	Sets the OpCode Filtration mode for the ECAP by specifying the manner in which OpCodes are filtered. (Start with all OpCodes being counted or no OpCodes being counted).	[1 for AllowAll, 2 for DiscardAll] Note: The default behavior for each mode is as follows: <ul style="list-style-type: none"> • AllowAll - All MSU packets will be counted by the ECAP. This is the default mode for the ECAP. • DiscardAll - All MSU packet counts are discarded by the ECAP.
Allow OpCodes	Sets the OpCodes which are counted by the ECAP. In DiscardAll mode, the specified Opcode will be added to the list of allowed OpCodes. In AllowAll mode, the specified OpCodes will be removed from the list of discarded OpCodes.	[OpCode Values]
Filter OpCodes	Sets the OpCodes which will be discarded by ECAP. In AllowAll mode, the specified OpCodes will be added to the list of discarded OpCodes. In DiscardAll mode the specific OpCodes will be removed from the list of allowed OpCodes.	[OpCode Values]
Display the List of Allowed / Discarded OpCodes	Displays a list containing all of the discarded or allowed OpCodes specified for the active mode.	
Return to the Default Behavior of the Active Mode [AllowAll, DiscardAll]	Clears the list of all the discarded or allowed OpCodes. This returns the active opcode filtration mode to the default behavior.	

4.140 Option for Subsystem Prohibit (Release 29.0)

Description

This feature allows the network operator the option to have selected subsystems still marked as prohibited even though an **MTP-RESUME** has been received (i.e. point code is allowed). This allows a clearer delineation between the concept of a point code and a subsystem for **SCCP Management**.



Note:

This feature does not contain any restrictions regarding **ITU/ANSI** point code formats.

The following figure provides an example of a network view of this feature.

Figure 4-42 SSN Prohibit Option Diagram

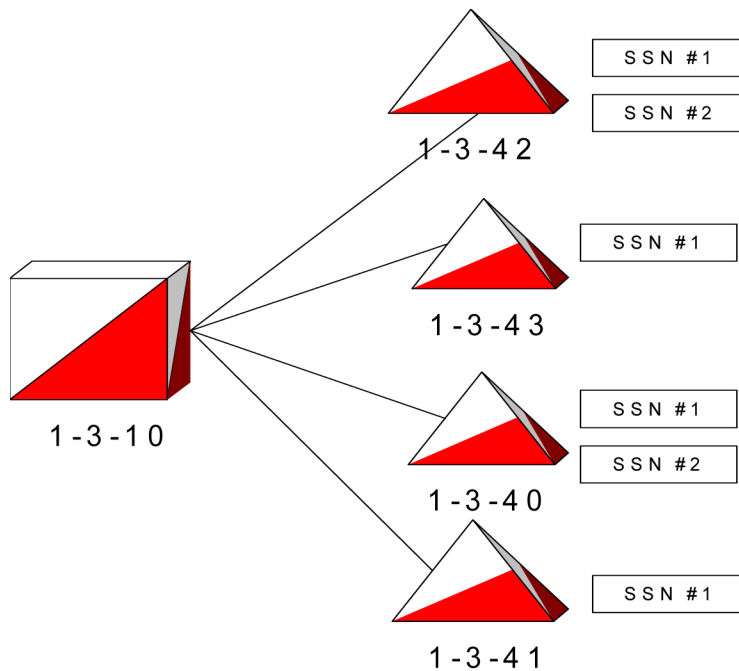

In this figure, **STP 1-3-10** is set up so that it is load sharing the application denoted by **SSN#1** across all **SCP's** and is in dominant mode (as primary) for **SSN#2**.

Currently, if point code 1-3-42 goes down, **EAGLE** marks all **SSN's** associated with 1-3-42 as prohibited and will broadcast **SSP's** to nodes contained in the respective **CSPC** group. The **EAGLE** will subsequently load share **SSN #1** across 1-3-43, 1-3-40, and 1-3-41. Traffic destined for **SSN #2** will be served by 1-3-40. This operation does not change for this feature.

Prior to this feature, when point code 1-3-42 came back in service and an **MTP-RESUME** was received, the **EAGLE** would:

1. Mark **SSN #1** and **SSN #2** related to 1-3-42 as allowed and broadcast **SSA's** to nodes contained in the respective **CSPC** group. This was done regardless of the actual status of the subsystem within the point code.
2. If **SSN #2** was still down at 1-3-42, the **EAGLE** would wait for a message destined for **SSN#2**, send the message to **SCP 1-3-42** and subsequently receive an **SSP** for **SSN#2** from 1-3-42.
3. **EAGLE** would then subsequently broadcast **SSP's** to nodes contained in the respective **CSPC** group, and initiate **SST's** to **SSN#2** to poll for subsystem status.

This feature changes the behavior in steps 1 and 2 above, when the option is on for both **SSN #1** and **SSN #2** for 1-3-42 to the following when an **MTP-RESUME** is received:

1. Send **SST's** to 1-3-42 concerning **SSN #1** and **SSN #2** and receive either an **SSP** or **SSA** from **SCP 1-3-42** concerning **SSN #1** or **SSN #2**.

2. Broadcast **SSA/SSP**'s, depending on the result of the **SST**'s, to nodes contained in the respective **CSPC** group.

Hardware Requirements

No new hardware is needed to support this feature.

4.141 Option for Turning on Class 1 Sequencing (Release 31.6.3)

Description

This feature addresses the problem where messages are sent as Class 1 even though they are not segmented or sequenced and the customer wants to be able to load share these messages among 8 **GTT** destinations.

The release 36.1.3 feature number 53481 "in-sequence delivery of Class 1 **UDT** messages," guarantees that Class 1 messages (both **XUDT** and **UDT**) are transmitted out of the **EAGLE** in the same order they are received. A by-product of the initial implementation of this feature is that the existing **GTT** load sharing mechanism (where a message can be load shared among 8 **GTT** destinations) no longer works for Class 1 messages. The Class 1 messages can only be delivered to a primary node with backup. This is a change to previous **EAGLE** behavior where Class 1 **UDT** messages could be load shared among 8 **GTT** destinations in the same manner as Class 0 messages.

The original thinking was that if a customer is using Class 1, they should not want them spread out among different end nodes. Even if they did, the thought was that they could simply use Random **SLS** Generation feature set to "Class 1" to get a load share distribution. However, due to the way the end node processes received traffic, they are unable to use Random **SLS** set to Class 1. As a result, the behavior of release 31.6 with Class 1 messages will break the current routing mechanism because there is no way to turn off the sequencing algorithm and go back to allowing full load sharing (but not guaranteed sequencing) on these messages.

An option is added to the **EAGLE** that turns **ON/OFF** the guaranteed in-sequence delivery of Class 1 (X)**UDT** messages. When **ON**, the **EAGLE** guarantees that these messages are delivered in the order they were received, but the messages will not be **GTT** load shared. When **OFF**, the **EAGLE** is able to **GTT** load share the messages but does not guarantee in-sequence delivery.

This design provides the option to turn **ON/OFF** the Class 1 Guaranteed Sequencing Algorithm. This requires storage, a user interface, and conditional logic to control Class 1 sequencing based upon the new parameter setting.

Limitations

EAGLE does not guarantee that Class 1 **ITU** messages will be delivered in sequence when **CLASS1SEQ** is **ON** and **RANDSLS** is **ALL**.

4.142 Option to suppress NumberPortabilityStatusIndicator in SRI_ACK (Release 42.0)

The Option to suppress NumberPortabilityStatusIndicator in SRI_ACK feature allows the Number Portability Status Indicator (**NPSI**) to be omitted from all SRI_ACK messages.

4.142.1 Feature Control Requirements

The G-Port (Part Number 893-0172-01) or IS41 GSM Migration (Part Number 893-0173-01) feature must be enabled before the functionality to suppress the NPSI can be provisioned.

4.143 Optional SCCP conversion for ITUi to ITUn and for ITUn to ITUi (Release 45.0)

The Optional SCCP conversion for ITUi to ITUn and for ITUn to ITUi allows SCCP conversion to be skipped for the Calling Party Address (CgPA), when the CgPA GT=RI and GTI=0 and when the domain crossing is from ITUi <-> ITUn.

This functionality is provisioned using the `chg-sccpopts` command.

4.143.1 Feature Control Requirements

The ANSI/ITU SCCP Conversion feature must be turned on before this functionality can be provisioned.

4.144 Origin-based MTP Routing (Release 35.0)

Description

The Origin-based Message Transfer Part (MTP) Routing feature allows traffic to be routed to the same destination through different networks, depending on the origin of the messages. This flexibility is achieved by enabling EAGLE 5 ISS to be configured to use additional criteria when making MTP routing decisions.

The Origin-based MTP Routing feature provides the following route types:

- DPC + OPC (processed first)
- DPC + originating linkset
- DPC + CIC

Note:

DPC + CIC routing is only applicable to ISUP messages that have the CIC field, not as a parameter.

- DPC + SI
- DPC (processed last)

If available, EAGLE 5 ISS always uses the route of a more preferred route type. Route cost is used to choose from routes of the same type. Therefore, a DPC + OPC route with a route cost of 20 is chosen ahead of a DPC + SI route with a route cost of 10.

The Origin-based MTP Routing feature introduces the DPC + OPC, DPC + incoming linkset, and DPC + CIC route types. These route types are considered exception routes, and do not factor into the availability status of a destination. A routeset is a collection of routes to a destination. Each routeset can have up to 6 routes, with 16 links to a route. An exception routeset is a collection of up to 6 exception routes that have the same DPC, exception class and criteria. If all of a destination's DPC-only routes become unavailable, the destination is considered unreachable by EAGLE 5 ISS, even if an exception route to that specific destination is still capable of carrying traffic.

New Concepts

The Origin-based MTP Routing feature introduces the following concepts:

- CIC Handling
- Network management and exception routes
- Congestion handling
- Circular route detection
- Gateway nodes
- SCCP handling

CIC Handling

The Origin-based MTP Routing feature allows exception routes to be entered based on the CIC and/or a range of CIC values. This feature uses the value placed after the routing label for all CIC triggers, instead of a CIC value placed within the mandatory fixed, variable or optional part.

Network Management and Exception Routes

The Origin-based MTP Routing feature operates on an end-to-end scheme instead of point-to-point to prevent impacts to routing. This management method has the following results:

- Adjacent point codes do not have exception routes.
- Exception routes do not factor into the status of a destination. A destination's status is only defined by the standard routes entered.
- If all the DPC-based routes to a destination are unavailable, then the status of the destination is listed as Prohibited even if exception routes are available.
- Preventative and broadcast TFX or TCX are not sent based on the status of exception routes. If an exception route is unavailable, the next exception route is chosen ending in the standard provisioned routes.

Congestion Handling

The CPC is the only identifying characteristic of a TFC message: therefore, the EAGLE 5 ISS cannot determine whether the message is a node or whether the route to the destination is congested.

The Origin-based MTP feature ensures that there are many routesets to a destination. However, the EAGLE 5 ISS is still unable to determine if the TFC is regarding an Exception or Normal route or if the node itself is congested. Therefore, once a TFC is received regarding a node within exception routes provisioned against it, the EAGLE 5 ISS lists all routesets to that destination as congested.

To ensure that the EAGLE 5 ISS has the correct congestion status of the destination, an RCT regarding the destination over each impacted route is sent. This ensures that the destination does not “bounce” in and out of congestion. The EAGLE 5 ISS starts T15 at the beginning of the broadcast and T16 at the completion; if the EAGLE 5 ISS receives a TFC regarding that destination in response to the poll, the EAGLE 5 ISS maintains the congestion level against it, even if it was received over a linkset which is part of an exception routeset.

Circular Route Detection

If the EAGLE 5 ISS detects that traffic originated from a route is to be sent back over the same route, it changes the status of the DPC to Prohibited, so that the linkset does not enter into congestion and potentially impact other valid routes. To reduce the impact to the true route of the DPC, the EAGLE 5 ISS prohibits only the impacted route to a destination, and not the destination itself. This ensures that only the route provisioned as the exception route is impacted if CRD is detected, and all other remaining traffic is able to reach the DPC.

 **Note:**

The `rst-dstn` command is the recommended method for clearing this CRD condition.

Gateway and Exception Nodes

The Origin-based MTP Routing feature allows the provisioning of exception routes across networks, where the OPC and DPC do not exist within the same network type (ANSI, ITU-I or ITU-N). However, exception routes are only provisionable through the full point code values, not aliases or clusters.

Each OPC used within a Gateway Exception Routeset must have an alias entry within the destination table for the network where the DPC resides.

SCCP Handling

The Origin-based MTP Routing feature provides the `MOBRSCCPOPC` SCCP option which allows the OPC to be selected in the routing header, the EAGLE 5 ISS TPC, or the `CGPA` OPC for SCCP routing.

Hardware Requirements

The Origin-based MTP Routing feature has the following hardware requirement:

- EAGLE 5 ISS cards:
 - LIM-ATM: 870-1293-02
 - EDCM: 870-2372-01
 - MPL/MPL-T: 870-2061-xx

- E1/T1 MIM: 870-2198-xx
- HC-MIM: 870-2671-xx
- TSM: 870-1289-xx, 870-1290-xx, 870-1291-xx, 870-1292-xx
- DSM: 870-1984-03

 **Note:**

The Origin-based MTP Routing feature does not support 2-Port LIM cards or Dual-Slot DCM cards.

Limitations

The Origin-based MTP Routing feature has the following limitations:

- The Origin-based MTP Routing feature cannot be used with LIMDSO/V35/OCU, LIM-E1, or Dual-Slot DCM cards.
- All destinations must have DPC-only routes.
- MTP Low Priority Route Set Test (MLPRST) must be turned on (`chg-stpopts` command) before this feature can operate.
- CIC-based routing is supported only for ISUP traffic.
- Adjacent routes cannot have exception routes.
- Exception routes do not factor into the status of a destination. A destination's status is defined only by the standard routes entered.
- If all DPC-based routes to a destination are unavailable, then the status of the destination is listed as Prohibited even if exception routes are available.
- CIC handing considers only the value after the MTP Routing Header and not any values within the ISUP parameters. This includes handling of CIC ranges.
- Full point code OPC criterion always takes precedence before wildcard OPC criterion regardless of the assigned route cost. For example, if an OPC exception criteria of 1-1-1 with a route cost of 20 and 1-1-* with a route cost of 10 are entered, 1-1-1 is used even though 1-1-* has a lower route cost.
- Exception routes for cluster exceptions do not inherit exception routes for the cluster member. Exception routes for the cluster exception must be applied individually if desired.

4.145 Origin-based SCCP Routing (Release 35.0)

Description

The **Origin-based SCCP Routing** feature allows EAGLE 5 ISS to route SCCP messages based on CdPA GTA, CgPA GTA, CgPA SSN, CgPA PC, and/or OPC fields.

This feature allows EAGLE 5 ISS to operate in CgPA GTT, Advanced (Adv) CdPA GTT, and CdPA GTT mode. These modes are combined in a GTT Mode hierarchy, which determines the preference of GTT modes and the order in which the fields are searched in incoming MSU.

The following GTT Mode Hierarchy combinations are supported by the Origin-based SCCP Routing feature:

- CdPA only
- Adv CdPA, CdPA
- CgPA, Adv CdPA, CdPA
- Adv CdPA, CgPA, CdPA
- Adv CdPA, CdPA, CgPA
- CgPA, CdPA
- CdPA, CgPA
- CgPA only

The Global Title Translation process starts with the first GTT Mode of the GTT hierarchy. If translation is found there, the whole GTT is stopped. If translation is not found in this first GTT Mode, the GTT process tries to find a translation in the next GTT Mode of the hierarchy.

The GTT Mode hierarchy can be configured on a system wide basis and on a per linkset basis. The system wide option is used to define the default value for all linksets by default. Each linkset can then be configured to use one of the GTT Mode Hierarchies. The linkset option overrides the system default for that linkset only. Any linkset that is not changed continues to use the system default.

In Adv CdPA mode, one or more of the following additional translations can be configured to apply on top of the mandatory CdPA GTA translation: none, CgPA GTA only, CgPA PC only, SELID only, CgPA GTA + OPC, CgPA PC + OPC, SELID + OPC, or OPC only. Each additional translation can have a subsequent translation on CgPA SSN.

In CgPA mode, a CgPA GTA translation with or without a subsequent CgPA SSN translation, or a CgPA PC translation with or without a subsequent CgPA SSN translation search (CgPA GTA and CgPA PC are mutually exclusive) can be configured. The search order is predefined and cannot be changed.

 **Note:**

The CdPA GTI is always validated before GT starts processing SCCP MSUs. The CgPA GTI is not validated: therefore, when a subsequent lookup in Adv CdPA GTT mode is based on SELID or for CgPA TT, the attempt to find a CgPA GTT Set in the GTTSEL table may fail because of an invalid or unsupported CgPA GTI in the arrived MSU.

Hardware Requirements

The Origin-based SCCP Routing feature has the following hardware requirements:

- The SCCP application must run on a DSM card or higher.
- No SCCP application can be provisioned in the system if TSM cards are used.

Limitations

The Origin-based SCCP Routing feature has the following limitation:

Due to a 150-character limit on command length, a single `ent/chg-gta` command may not fit in a single line, especially for range entries with MGTT parameters. If an `ent-gta` command does not fit on one line, execute the command with fewer parameters, then execute `chg-gta` to modify the translation. If the `chg-gta` command does not fit on one line, break it into multiple commands.

4.146 Output Measurements File Size Reduction (ECAP 41.1)

The Accounting File Size Reduction feature provides various options to reduce the output measurement file. Reducing the size of the output measurement file will decrease the transfer time and the congestion experienced on the network during the file retrieval period by the Aggregator.

- [Variable Measurements Collection Period](#)
- [Variable File Transfer Offset Time](#)
- [Multiple Output File Formats](#)
- [Compression of Output Measurement Files](#)

4.146.1 Measurement File Reduction Options Added to the ECAP Configuration Menu

[Table 4-33](#) and [Table 4-34](#) display the parameters that can be configured to reduce the size of the output measurements file using the `ecapcfg`.

Table 4-33 Measurement File Configuration Menu Options

Menu Option	Description
Measurement File Format	Sets the output format for the measurement files. File format can be XML or CSV. By default, this field will be set to XML.
Measurement File Compression Required	Compresses the output measurement data files before they are transferred to the Aggregator. By default, this field will be set to N (disabled).
Data Write Intervals	Sets the interval, in minutes, at which the Integrated Accounting Feed application generates the data file. By default, the data write interval will be set to 5.

Table 4-34 File Mover Configuration Menu Option

Menu Option	Description
File Transfer Time	Sets the number of minutes after the half hour that data files are sent to the Aggregator. By default, the file transfer time will be set to 5.

4.146.2 Variable Measurements Collection Period

The provisioned time period that the ECAP collects measurements before writing to a measurement file is specified by the Data Write Interval. The ECAP server generates a measurement data file per data write interval.

By default, the data write interval is set to 5 minutes. The Data Write Interval field can now be configured at run-time using the `ecapcfg` tool. This time interval can be set to 1, 5, 10, 15, or 30 minutes.

For more information on the variable measurements collection period option, refer to [Table 4-33](#).

4.146.3 Variable File Transfer Offset Time

The ECAP server generates a measurement data file per data write interval. These files are stored on the ECAP server and transferred to the Aggregator at periodic intervals of 30 minutes.

The File Transfer Offset field sets the number of minutes after the half hour at which the Measurement files are sent to the Aggregator. For example if the value is set to 5 for a collector, then the measurement files will be transferred at clock timings of `xx:05` and `xx:35`.

By default, the file transfer time is set to 5 minutes. The File Transfer Time field can now be configured at run-time using the `ecapcfg` tool. The time interval can be any integer value ranging from 1 to 29.

For more information on the variable file transfer offset option, refer to [Table 4-34](#)

4.146.4 Multiple Output File Formats

The ECAP will be capable of creating output measurement files in any of the two formats:

- XML
- Comma Delimited ASCII (CSV)

The CSV format will enable reduction of the size of the output measurement file. This not only enables minimum space usage, but also enables a faster rate of data transfer to the Aggregator.

Each measurement file will follow a single format. By default, the measurement files are created in XML format. The Measurement Files Format field can be changed at run time with the `ecapcfg` tool. When the file format is changed from one format to another, the new file format is used for the creation of new output files. Any old/ historical files stored on the ECAP will not change.

For more information on the multiple output file format option, refer to [Table 4-33](#) .

4.146.5 Compression of Output Measurement Files

The ECAP will now be capable of reducing the size of the output (XML or CSV) file by applying a compression scheme. To accomplish this requirement, ECAP will use `gzip` compression tool.

By default, no compression is applied to the output files. This configuration can be changed at run-time with the `ecapcfg` tool. After the compression option is enabled on the `ecapcfg` tool, the compression scheme is applied to the files.

For more information on the compression of e output measurement files, refer to [Table 4-33](#).

5

Features P - Z

This chapter describes features starting with letters from P to Z.

5.1 Password Aging (Release 21.0)

When a password is changed, either by the user or by a systems administrator, the date that the change took place is entered in the database along with the updated password.

During the login process, after the system has verified that the user has correctly entered the password, the system uses the date the password was changed to compute the number of days that have elapsed since the password was last changed. The password's age is compared against the value of the `page` parameter (maximum password age) of either the `ent-user`, `chg-user`, or `chg-secu-dflt` commands. If the password's age is greater than the value of the `page` parameter, then a password expired message appears in the command area. The user is prompted to enter and verify a new password. If the new password is acceptable, it is entered in the database along with the date that the change took place (the current date as shown by the **EAGLE** time-of-day clock).

The maximum age of a specific password (`page`) can only be specified with the `ent-user` command or the `chg-user` command. If the `page` parameter is not specified with the `ent-user` command, then the password's age is taken from the system default value. The system default value for the password's age is set with the `page` parameter in the `chg-secu-dflt` command. If the `page` parameter is not specified with the `chg-user` command, then the existing value for the password's age does not change.

The system administrator can set a password's maximum age to 0. This indicates that the password aging is not applied to the password and the password remains valid regardless of how many days have elapsed since it was last changed.

When the user attempts to login with a password that is older than its maximum allowable age, the following message is displayed in the command area after the password has been validated and before the login session is established:

```
Enter new password (password has expired and must be changed) :
```

The user is then prompted to enter and verify a new password. If the password is acceptable, the user is logged on. Otherwise, one of the invalid password error messages is displayed (see [Password Requirements \(Release 21.0\)](#)) and access to **EAGLE** is denied.

5.2 Password Encryption (Release 21.0)

To prevent passwords from being disclosed, in Release 21.0, the passwords are stored on the system in an encrypted form. The encryption algorithm that is used is a one-way encryption algorithm, meaning once the passwords are encrypted using the algorithm, the passwords cannot be decoded. Also, any passwords temporarily stored in memory are overwritten with null characters as soon as they are no longer needed.

5.3 Password Requirements (Release 21.0)

Currently, the only requirement for a password used in the **EAGLE** is that the password must contain from five to eight alphanumeric characters

In Release 21.0, the rules for passwords have changed to meet Bellcore password requirements. The requirements for passwords can now be configured in the database with the `chg-secu-dflt` command. Passwords on the **EAGLE** can contain a maximum of 12 characters.

Refer to the *Commands Manual* for current information on commands.

5.4 PCS 1900 LNP Query (Release 26.0)

Description

This feature provides for **LNP** query/response in a **PCS** wireless environment using the **LRN** method in order to support Service Provider Number Portability, thus extending **EAGLE**'s **LNP** capability.

PLNP addresses the following capability in the network:

Call Completion to Ported Number (**CCPN**)

This network facility allows completion of a call to a ported directory number, when an **MSC** trigger is used (i.e. the **MSC** must be an **LNP**-capable switch). For **PLNP**, the **MSC** sends a query containing a **DN**, which is a 10-digit **NANP** called party number for a wire-line subscriber. The **DN** is used to perform an **LNP** database lookup in order to find the associated **LRN**.

Feature Functions

In order to support this new capability, **PLNP** utilizes the following, currently existing, **LNP** functions:

1. **LNP** Query processing: This function services **LRN** queries in real-time and generates associated **LRN** values. Multiple query types (**AIN**, **IN**, **IS-41**) are supported.
2. **LNP Database**: The database supports **LNP** Query and Message Relay processing, though Message Relay functionality is not supported in the industry.
3. **SCCP** Subsystem Management: **SCCP** supports local subsystems. This includes routing to a local subsystem, and performing network management when a local subsystem goes online or offline.
4. **Database Audit**: This periodically audits the **LNP Database** to ensure that it has not been altered by unapproved mechanisms, and to ensure that all cards have an identical copy of the **LNP Database**.
5. **LNP** related Administration: Support is in place to provision the existing **LNP** services. Support for provisioning the **PLNP** service has been added to the existing commands.
6. **LNP**-related Maintenance: Maintenance supports **LNP**. This includes reporting the status on the **LNP** subsystem, and generating alarms, measurements, and **UIMs**. Minor enhancements have been made to the `REPT-STAT-LNP` command.

No new alarms are introduced for this feature. Although no new measurements or **UIMs** have been defined, measurements for **PLNP** will be maintained and reported separately from other **LNP** query services.

7. **LSMS** and the **LSMS ↔ EAGLE** interface: No impact on these functions.

PLNPQS Details

All the **LNP** query messages for call completion to ported number received by **EAGLE** are processed by **PLNPQS**. **PLNPQS** receives queries from the subsystem management task, and implements the processing to parse the query, perform the lookup, and generate the response.

LNP Query is performed as follows:

1. The message arrives at **EAGLE**.
2. If global title is required, and the translation type is **PLNP**, the data is routed to the local **LNP** query subsystem and Site **ID True Point Code (SID)** and **SS_APPL** tables). Only one **LNP** subsystem exists for all **LNP** query processing. If **SID/SS_APPL** data has not been administered, a **UIM** is generated and the message is discarded.
3. If global title is not required, the message is routed to the appropriate destination, local subsystem if the **EAGLE DPC** and **SSN** are the destination, **MTP** routed for others.

PLNPQS Query Verification

This section shows the process used by **EAGLE**, as part of **PLNPQS**, to verify a **PLNP** query.

A summary of the verification follows.

PLNP will verify the following values in the **MTP** and **SCCP** part:

1. **MSU** is **ANSI** national, and point codes are national
2. **MSU** is **SCCP UDT** message
3. **MSU** is **SCCP** Class 0
4. **GTI** is 0010 when rt-on-gt, or 0000 when rt-on-ssn
5. **TT** is the provisioned **PLNP TT** value
6. **PC** of originating **SSP** is in route table, extract **PC** and **SSN** for use in the response
7. Length of user part sufficient to hold minimum **TCAP** part

PLNP will verify the following values in the **TCAP** part:

1. **TCAP** package is Query with Permission
2. **TCAP** package length fits within **SCCP** user part
3. **TCAP** transaction **ID** present, and length = 4, extract value for use in the response
4. Component sequence **ID** present, and length valid
5. Invoke Last component present, and length valid, extract Invoke **ID** for use in the response
6. **PCS** ProvideInstructions:Start operation code present
7. Digit **ID** parameter, Called Party Number present
8. Calling Party Number, **LATA**, and **ORG** station are present

PLNPQS Query Decoding

This section shows the process used by **EAGLE** to decode a **PLNP** query. The process is identical to the existing **EAGLE** implementation to decode **IN** queries, except that:

- the numbering plan for this query is E.164, rather than E.163
- the dialed number must be exactly 10 digits, rather than at least 10

PLNP will verify the following values in the **TCAP** part:

1. **TCAP** length valid
2. Parameter Set present, and length valid
3. Service **Key** present, and length valid
4. Digit **ID** parameter, Called Party Number is present, length is valid, and the following applies:
 - Type is National
 - Encoding is **BCD**
 - Numbering Plan is **ISDN** (E.164)
 - 10 digits present
 - Each digit is correctly encoded (**BCD** value is 0 to 9, inclusive)

PLNPQS Query Response Generation

PLNPQS response messages can be of the following types: normal messages and error messages.

Normal Responses

This section shows the fields filled in by **EAGLE** for a "normal" response to a **PLNP** query. The normal response is sent when the query passes verification and decode, and an **LNP** database lookup is performed.

Normal responses are identical to the existing **EAGLE LNP** implementation for **IN** query/response, except that the numbering plan used for the query and response will be E.164 (**ISDN**), rather than E.163 (Telephony).

The Routing Number in the normal response is filled in as follows:

- if the database lookup succeeds and returns an **LRN**, the Routing Number in the response is set to the **LRN** value (i.e. the **DN** refers to a ported number).
- if the database lookup fails (i.e. the number is not ported), the **DN** value from the query is used as the Routing Number in the response.

The normal **PLNP** response is required to include the Digits(Carrier), and Billing Indicators parameters. These parameters are not essential for number portability, but are mandatory parameters for the response. Each will be set to a benign filler value, as shown in the template.

Error Responses

MTP and **SCCP** level error responses are unchanged from the existing **EAGLE** implementation.

The general rule for error responses are as follows:

- Protocol errors in the component portion (incorrect package or component) are reported with a Reject component in a Response package
- Command errors (where the query completed with an error, though the command was received correctly) are reported with a Return Error component in a Response package

Error handling for **PLNP** will come into play once a message is routed to the **PLNPQS** for handling as a **PLNP** request.

Upgrade Considerations

Adding additional measurements to support the feature will result in the **SCCP** maintenance block being modified. During upgrade, **OAM** must support the old and new version at the same time. During an upgrade back out, the **SCCP** card must support polling for the old version.

Since this feature does not change any **DMS** tables, no table conversion will be required.

All **SCCP** cards must be upgraded to the release that contains **PLNP** prior to provisioning the **PLNP** service.

Limitations

1. When the **PLNP** feature is enabled, and the **PLNP** service is provisioned, it is not possible to route **PLNP** queries arriving as **Route** on **GT** to an external node. All **Route-on-GT PLNP** queries will be processed locally under these conditions. This means that customers will not be able to split processing of **PLNP** queries across multiple network elements.

The product is implemented in this manner in order to retain backward compatibility with the current **LSMS** product. Rather than utilizing the **LSMS** to provision **PLNP** service on a per **NPA-NXX** basis, the **PCS** query service is enabled/disabled for all messages.

2. Due to limitation 1, when the **LNP** database is unavailable, **EAGLE** will return an error response without performing **LNP**. Network management for these **LNP** queries will be used to divert future traffic. A summary of the network management response is shown in [Table 5-1](#).

Table 5-1 Response When PLNP Is Unavailable

Query MSU Routing Indicator	DPC	Message Handling	Network Management
Rt-on-gt	True point code	generate UDTS	Send UPU
	Capability point code	generate UDTS	Send TFP concerning EAGLE's CPC
Rt-on-ssn	True point code	generate UDTS	Send SSP to OPC concerning DPC
	Capability point code	generate UDTS	None

3. **PLNP** only supports **ANSI** messages.
4. There is no Automatic Code Gapping (**ACG**) for **PLNP**. Excessive **PCS** query messages can cause **ACG** to be initiated for **AIN** and **IN** queries, potentially starving out those services if the excessive **PCS** query messages continue to be sent to **EAGLE**.
5. Message Relay is not supported for messages which use the **PLNP Translation Type**.

5.5 PDBA Proxy (EPAP 7.0)

Description

The EPAP PDBA Proxy feature provides a more reliable connection to the **EPAP PDBA** in the event of a failure of the active **PDBA**. Connection redundancy is accomplished by allowing the customer's provisioning system to still use a single **IP** address, even though the connection may logically be to the previously standby **PDB**.

During normal provisioning operations, one **PDBA** is active and the other **PDBA** is in standby. However, from the customer's provisioning system perspective, the active and standby **PDBAs** are accessible through a single **IP** address. If the active **PDBA** fails, the local **EPAP B** box will forward provisioning updates to the mated **PDB**.

When the previously active **PDBA** recovers, it is aware that the standby **PDBA** has become active and now both active **PDBAs** need to be reconciled.

The advantages this feature provides are:

1. The customer's **G-Flex** network can absorb a single **EPAP** failure and automatically transfer provisioning to the standby **PDBA** using the same **IP** address.
2. A means of reconciling both active **PDBAs** when the failed **PDBA** becomes available again.

Limitations

1. The **EPAP PDBA** Proxy feature cannot be installed on a non-provisionable site.
2. This feature does not require the **ADR** feature.
3. This feature only provides Virtual **IP** functionality when the **EPAP-A** fails.
4. Failure of the network connection to both **EPAP A** and **B**, or similar failures that take down both devices require the customer's provisioning system to manually connect to the standby **PDB's IP** address.

5.6 Performance Enhancements (IP⁷ Release 3.0)

The Performance Enhancements feature provides a set of rules for specifying **DCM** throughput under different configurations. This feature touches on a wide variety of **IP⁷** Secure Gateway system and application issues.

Primary Aspects

The following items can be considered primary aspects of the Performance Enhancements feature:

- Maximum application capacity per **DCM** is increased to 3000 **MSUs** per second, with limitations.
- **DCM** communications processor **MSU** throughput capacity is increased to 5000 per second.
- The software-imposed limit to maximum **TVG** request rate is increased to 5000, which requires a limit on active cards present in the system.

- Application performance is enhanced through the use of Nagle's algorithm on all sockets. For more information on Nagle's algorithm, see [Nagle's Algorithm](#).
- Application performance is enhanced through optimizations in the use of shared memory.
- The `msucount` pass-through maintenance command, used with the `pass` command, is enhanced to provide values for average **MSUs** per second transmitted and received over a period of time.

Secondary Aspects

The following items can be considered secondary aspects of the Performance Enhancements feature:

- The **TCP/IP** stack is modified such that the timer used for Nagle's algorithm has a much lower time-out, such as 25 milli-seconds rather than 200 milli-seconds.
- Socket message flow control is modified for the higher capacity.
- **TCP** re-transmissions at the higher capacity is addressed by increasing socket buffer size from 8 kilo-bytes to 16kilo-bytes.
- The card-level congestion control algorithm is modified for the higher capacity.
- The change-over/change-back control algorithm is modified for the higher capacity.

Limitations Summary

Achievement of the maximum application capacity of traffic requires the following:

- No more than 150 active cards may be present in the system.
- Average **MSU** size of application traffic must be no greater than 120 octets.
- **STPLAN** copy on outbound messages is not supported at the capacity rate of traffic, but is still supported at rates up to 2000 **MSUs** per second.
- Nagle's algorithm must be enabled for all traffic-carrying sockets.

5.7 Per-Linkset Random SLS (Release 36.0)

Description

The Per-Linkset Random SLS (Signaling Link Selection) feature is an enhancement of the existing Random **SLS** Generation feature, to allow the user to apply Random **SLS** generation on selected linksets instead of system-wide to all linksets. The **Per-Linkset Random SLS** feature provides an **STP** option that can help to resolve load balancing problems on specific linksets without affecting the entire routing scheme of the **EAGLE 5 ISS**.

The **EAGLE 5 ISS** uses the Random **SLS** option to decide if it has to generate a new **SLS** value. This randomly generated **SLS** value is used to select an outgoing linkset and a link to achieve load balancing. Linkset provisioning is enhanced to allow configuring of specific linksets for Random **SLS** generation.

To use the feature in an upgraded system that has the Random **SLS** option set to **CLASS0** or **ALL**, the operator must provision the individual linksets and per-linkset options appropriately before changing the **STP** option to function per linkset.

The **Per-Linkset Random SLS** feature can operate on both **ITU SCCP** Class 0 and **ITU SCCP** Class 1 traffic. The **Per-Linkset Random SLS** feature allows each linkset to inherit all

the options related to **SCCP** Class 0 and Class 1 traffic that are currently available for the Random **SLS** Generation feature.

Hardware Requirements

None

Limitations

Different **Per-Linkset Random SLS** configurations on two linksets that are part of a combined linkset for the routes defined for a destination node might result in undesired **SLS** distribution. The **EAGLE 5 ISS** does not prompt or reject the linkset provisioning command if provisioning will result in an undesired **SLS** distribution.

5.8 Persistent Device States (Release 29.0)

Description

This feature provides persistent states for supported **EAGLE** card, terminal, signal link and **TCP/IP** link devices. This capability makes it unnecessary to manually log device states prior to an `init-sys`, and retains the **OOS-MT-DSBLD** device state during an **OAM** switchover. Supported devices are cards, terminals, **SS7** signaling links and **TCP/IP** data links.

During the `init-sys` process, the **OAM** will restore supported devices to their maintenance states, resulting in an initialized and configured **EAGLE**. Non-supported devices continue to be processed using the current method.

This feature presents a very efficient mechanism to restore an **EAGLE** to its pre-`init-sys` state. This `init-sys` aspect of the feature is controlled by a system wide "restore device" option administered by the craftsperson with the `chg-stpopt` command. Turning off this option causes the current `init-sys` processing to occur.



Note:

The default value for this option remains **OFF**.

With this feature, faster standby-to-active recovery during a switchover operation are possible, since device states are maintained on the standby **MASP**, and do not require craftsperson intervention following initialization. Disabled or inhibited devices retain their state, provided the **PDS** data is valid. Otherwise, current switchover processing occurs, and devices may be driven to their default state.

Hardware Requirements

No new hardware is needed to support this feature.

Limitations

Persistent state data will not be maintained on the standby **MASP**, in the case of different version numbers for the **PDS** tables in the active and standby **MASPs**. The **PDS** table version changes only if there are new devices supported by the **PDS**, or more information is added to the table for the supported devices.

5.9 Point Code and CIC Translation (Release 43.0)

The Point Code and CIC Translation (**PCT**) feature allows the EAGLE 5 ISS to change the destination point code (**DPC**) or originating point code (**OPC**) of an MTP-routed MSU to previously configured values. This functionality allows external networks to continue using the old point codes by emulating and mapping them to the new real point codes within the networks. The feature can also be used to change the circuit identifier code (**CIC**) of the MSU.



Note:

ITUN24 point codes, spare point codes, and private point codes are not supported by PCT translations.

A new PCT table is used to define translations between real and emulated point codes.

Network nodes can send and receive traffic to and from the emulated point code (**EPC**) without 'knowing' the real point code (Real PC) that is being emulated by the EPC. This ability allows the Real PC to be changed transparently from the rest of the network, which can continue using the EPC to route traffic.

If PCT is configured, either system wide or for the incoming linkset, then a DPC lookup is performed on the incoming MSU. If a translation is found during the DPC lookup, then the DPC of the MSU is replaced by the Real PC as the MSU is received by the EAGLE 5 ISS. If a Real CIC was provisioned in the translation, then the CIC of the MSU is changed to the value from the Real CIC range.

If the MSU was not modified by the DPC lookup, then an OPC lookup is performed on the outgoing MSU. If a translation is found during the OPC lookup, then the OPC of the MSU is replaced by the EPC of the matching translation as the MSU leaves the EAGLE 5 ISS. If an Emulated CIC was provisioned in the translation, then the CIC of the MSU is changed to the value from the Emulated CIC range.

Features and functionalities in the EAGLE 5 ISS use the real point code in provisioning.

The PCT feature is a quantity feature. The quantity is used to define the maximum number of allowed translations.

5.9.1 Feature Control Requirements

- FAK for the Part Number of the desired quantity feature:
 - 893-0372-01—25 translations
 - 893-0372-02—50 translations
 - 893-0372-03—75 translations
 - 893-0372-04—100 translations
 - 893-0372-05—150 translations
 - 893-0372-06—200 translations
 - 893-0372-07—250 translations
 - 893-0372-08—1000 translations

- After a PCT feature has been enabled, a PCT feature with a lower quantity cannot be enabled.
- A temporary FAK cannot be used to enable the feature.

5.9.2 Hardware Requirements

The `pct pass` command is not supported on E1/T1 MIM, E1-ATM, LIM-ATM, and MPL cards.

5.9.3 Limitations

All Network Management may not work fully due to the overlap of CIC across multiple point codes.

5.10 Point-to-Point Connectivity for ITU Point Codes (IP⁷ Release 2.2)

Description

The `iplimi` application provides the same functions for International Telecommunications Union (ITU) point codes as the `iplim` application provides for **American National Standards Institute (ANSI)** point codes, with the exception of any functions that are supported only by **ANSI** protocols. (Full Restart, Partial Restart, Adjacent Restart, False **Link** Congestion, and **Circular Routing** Detection are **ANSI**-only features.)

Each `iplimi` link provides one point-to-point connection either to an international ITU network node (ITU-I) or to a national ITU network node (ITU-N) for the purpose of carrying **SS7** traffic over a **TCP/IP** network. These links:

- Can be added to a multiple-link linkset in which the other links can be either `iplimi` links or links of another type, such as `css7itu`.
- Fully support **SS7** changeover and changeback procedures, including retrieval.
- Have the standard **SS7** restriction of 16 links per linkset.

Mixed Networks Using the ANSI/ITU Gateway Feature

If you have also installed the **ANSI/ITU** Gateway feature (previously available for **SS7** networks only), the addition of the `iplimi` application enables the IP⁷ Secure Gateway to use the **ANSI/ITU** Gateway feature for IP networks as well. Using these features enables IP⁷ Secure Gateway to act as an interface between nodes that support **ANSI**, ITU-I, and ITU-N protocols. [Figure 5-1](#) shows an example of a complex network that includes all these types of nodes. [Table 5-2](#) provides more detail about the nodes, network types, and point codes used in this example.

The following **SS7** protocol constraints determine how the network must be configured:

- A linkset is a group of links that terminate into the same adjacent point code. All links in the linkset can transport compatible **MSU** formats. The network type of the linkset is the same as the network type of the adjacent point code assigned to the linkset.

- When nodes in different networks need to communicate, each node must have either a true point code or an alias point code for each of the network types. For example, if Node 1 (in an **ANSI** network) needs to communicate to Node 7 (in an **ITU-N** network), Node 1 must have an **ANSI** true point code and an **ITU-N** alias point code, while Node 7 must have an **ITU-N** true point code and an **ANSI** alias point code.
- **STPs** are usually deployed as mated pairs. The links connecting the **STP** to its mate are C links. Each **STP** must have a C linkset for each network type that the **STP** connects to. Therefore, in [Figure 5-1](#), Nodes 5 and 6 are connected with three linksets, one each for **ANSI** traffic, **ITU-I** traffic, and **ITU-N** traffic.
- To perform routing, the **IP⁷** Secure Gateway must convert the routing labels in **MSUs**. To perform this conversion, every destination point code (**DPC**), originating point code (**OPC**), and concerned point code must be defined in the routing table. Even if the **IP⁷** Secure Gateway does not route **MSUs** to these nodes, they must be provisioned in the routing table to provision the alias point codes required in the conversion process.

Figure 5-1 Complex Network with ANSI, ITU-I, and ITU-N Nodes

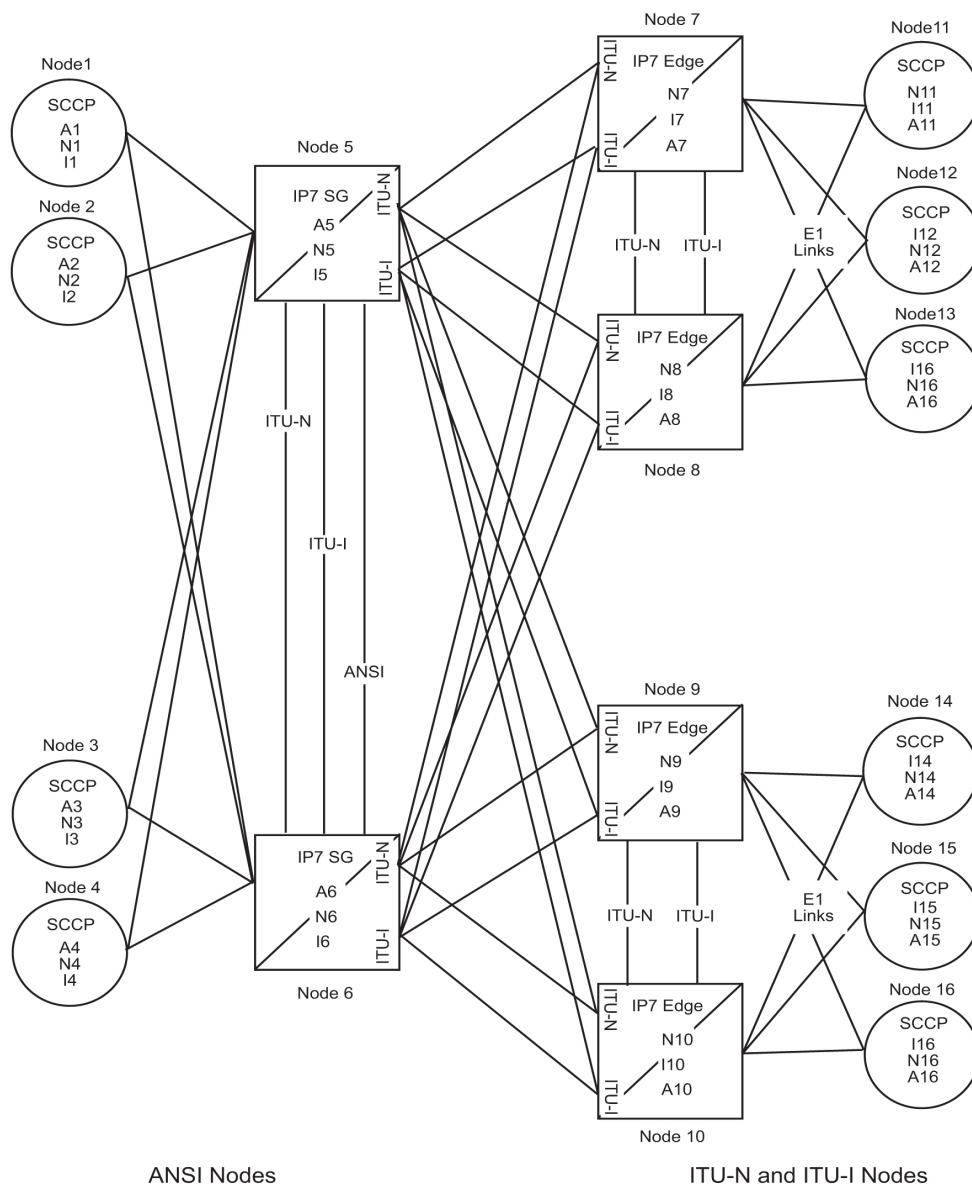

Table 5-2 Nodes and Point Codes in Complex Network Example

Node	Node Type	Network Types Supported	True Point Codes ¹	Alias Point Codes ²
1	SSP	ANSI	A1	N1, I1
2	SSP	ANSI	A2	I2
3	SSP	ANSI	A3	N3, I3
4	SSP	ANSI	A4	N4
5	STP (with IP ⁷)	ANSI, ITU-N, ITU-I	A5, N5, I5	
6	STP (with IP ⁷)	ANSI, ITU-N, ITU-I	A6, N6, I6	
7	STP (with IP ⁷)	ITU-N, ITU-I	N7, I7	A7

Table 5-2 (Cont.) Nodes and Point Codes in Complex Network Example

Node	Node Type	Network Types Supported	True Point Codes ¹	Alias Point Codes ²
8	STP (with IP ⁷)	ITU-N, ITU-I	N8, I8	A8
9	STP (with IP ⁷)	ITU-N, ITU-I	N9, I9	A9
10	STP (with IP ⁷)	ITU-N, ITU-I	N10, I10	A10
11	SSP	ITU-N	N11	I11, A11
12	SSP	ITU-I	I12	N12, A12
13	SSP	ITU-I	I13	N13, A13
14	SSP	ITU-N	N14	I14, A14
15	SSP	ITU-I	I15	N15, A15
16	SSP	ITU-I	I16	N16, A16

Notes:

1. A true point code (TPC) defines a destination in the IP7 Secure Gateway's destination point code table. **ATPC is a unique identifier of a node in a network.** Each Signal Transfer Point (STP) must have a TPC for each network type that the STP connects to. Each Service Switching Point (SSP) connects to only one type of network, so it has only one TPC.
2. An alias point code is used to allow nodes in other networks to send traffic to and from an STP or SSP when the STP or SSP does not have a TPC for the same network type.

The many configured links and point codes in the complex network shown in [Figure 5-1](#) allows most nodes to communicate with other nodes. However, note that Node 2 cannot communicate with Node 13 or Node 16 because Nodes 13 and 16 do not have **ANSI** alias point codes.

Routing and Conversion Within a Single Network Type

The following steps demonstrate how an IP⁷ Secure Gateway routes and converts **MSUs** that one ITU-N node sends to another ITU-N node. For example, assume that Node 11 in [Figure 5-1](#) sends an **MSU** to Node 14. The **MSU** is routed from Node 11 to Node 7 to Node 5 to Node 9 to Node 14. The following steps describe the actions performed at Node 5 (an IP⁷ Secure Gateway):

1. An ITU-N formatted **MSU** (which has a network identifier (NI)=10b and a 14-bit destination point code/originating point code) is received on an `iplimi` card (for this example at location 1103).
2. **MSU** discrimination is performed with the following substeps:
 - a. Compare the received network identifier (NI) to the list of valid NIs. (Each configured linkset for a receiving link has a defined list of valid NIs.) If the comparison fails, the **MSU** is discarded and an **STP** measurement is logged. In this example, the received NI (10b) is valid for an `iplimi` card.
 - b. Extract the NI and destination point code (DPC) from the received **MSU**.
 - c. Determine whether the destination of the received **MSU** is this **STP**. If not (as is the case in this example), the **MSU** is passed to the **STP**'s routing function.

3. The routing function selects which outgoing link to use by searching a routing table for an entry for the **DPC** (N14 in this example). The routing table identifies another `iplimi` card (for this example at location 1107) to be used for the outgoing link.
4. Determine whether **MSU** conversion is required (required when the source network type is not the same as the destination network type). In this example, both Node 11 and Node 14 are **ITU-N** nodes, so conversion is not required.
5. Forward the **MSU** across the Interprocessor Message Transport (**IMT**) bus from location 1103 to location 1107, where the **MSU** is transmitted out the link towards Node 14.

Routing and Conversion Between Different Network Types

The routing and conversion steps performed by an **IP⁷** Secure Gateway when an **ITU-N** node sends an **MSU** to an **ITU-I** node are the same as the steps shown in “[Routing and Conversion Within a Single Network Type](#)”, except for the conversion step.

For example, assume that Node 11 in [Figure 5-1](#) sends an **MSU** to Node 16. The **MSU** is routed from Node 11 to Node 7 to Node 5 to Node 9 to Node 16. The following steps describe the actions performed at Node 5 (an **IP⁷** Secure Gateway):

1. Perform steps 1 through 3 as shown in “[Routing and Conversion Within a Single Network Type](#)”. In this example, assume that the routing function determines that the outgoing link is configured on the **DCM** card at location 1203.
2. Determine whether **MSU** conversion is required (required when the source network type is not the same as the destination network type). In this example, Node 11 is an **ITU-N** node and Node 16 is an **ITU-I** node, so conversion is required. Conversion consists of two phases: **Message Transfer Part (MTP)** conversion and user part conversion.
3. Perform **MTP** conversion (also known as routing label conversion). The following parts of the **MSU** can be affected by **MTP** conversion:
 - Length indicator—for **ITU-N** to **ITU-I** conversion, the length of the **MSU** does not change
 - **Service Information Octet (SIO)**, Priority—for conversion to **ITU**, the priority is set to 0. For conversion to **ANSI**, the priority is set to a default of 0, which can later be changed based on user part conversion.
 - **Service Information Octet (SIO)**, Network Indicator—the **NI** bits are set to the **NI** value for the destination node. In this example, **NI** is set to 00b.
 - Routing Label, **Destination Point Code (DPC)**—the **DPC** is replaced with the destination’s true point code. In this example, N16 is replaced by I16.
 - Routing Label, **Originating Point Code (OPC)**— the **OPC** is replaced with the appropriate network type’s alias point code for the originating node. In this example, N11 is replaced with I11.
 - Routing Label, **Signaling Link Selector (SLS)**—no **SLS** conversion is required between **ITU-I** and **ITU-N** nodes. However, if one of the nodes were an **ANSI** node, conversion would be required between a 5-bit or 8-bit **SLS** for **ANSI** nodes and a 4-bit **SLS** for **ITU** nodes.
4. Perform user part conversion, if necessary. Currently, only **SCCP** traffic and network management messages have additional conversion. All other user parts have their data passed through unchanged.

5. Forward the **MSU** across the Interprocessor Message Transport (**IMT**) bus from location 1103 to location 1203, where the **MSU** is transmitted out the link towards Node 16.

5.11 Portability Check for Mobile Originated SMS (Release 29.1)

Description

In **GSM** networks, when a mobile subscriber sends a short message, or Mobile Originated Short Message Service message (**MO SMS**), using his or her handset, the message is first deposited in a Short Message Service Center (**SMSC**). This **SMSC** is then responsible for determining where the intended recipient, who is also a mobile subscriber, is located. The **SMSC** accomplishes this by querying the Home Location Register (**HLR**) of the recipient to determine which Mobile Switching Center (**MSC**) the subscriber is currently on. Once the location is determined, the **SMSC** sends the **SMS** to the recipient.

In a portability environment, this could lead to problems. The **SMSC** address to which a message is routed is programmed into the **GSM** mobile handset. When a subscriber ports to another network, the handset is reprogrammed with the **SMSC** address for the new network. However, the subscriber could then change this address back to the address from his old network. This would cause **SMS** to be incorrectly sent to the subscriber's old network **SMSC**, rather than to the new network **SMSC**. Since the old network would not have billing records for the ported-out subscriber, the subscriber essentially would receive free **SMS** service.

The Portability Check for Mobile Originated **SMS** (**MNP SMS**) feature is designed to prevent such a possibility from occurring. With this feature, the **EAGLE** filters incoming messages based on **MAP** Operation Code. If the message is a **MO** Forward Short Message (**MO FSM**), the originating subscriber's Mobile Subscriber **Integrated Services Digital Network** (**MSISDN**) number (i.e. phone number) is used to search the G-Port Mobile Number Portability database.

If a match is found, indicating the subscriber has been ported-out, the **EAGLE** uses the destination **SMSC** address obtained from the **SCCP CdPA** to search a list of "home network" **SMSC** addresses. If a match is found, indicating the ported-out subscriber is attempting to send a short message using the old network's **SMSC**, the message is discarded. An error message is then generated and returned to the originating **MSC**.

When the **MNP SMS** feature is on, the **EAGLE** performs the following functions:

1. **EAGLE** receives a **UDT** message.
2. Checks if the service selector matches G-Port. If so, continues to Step 3; else goes to step 16.
3. Checks if the CdPA **SSN** matches one of the **SSNs** provisioned with object type as **MSC**. If so, continues with Step 4. If the **CdPA SSN** matches one of the **SSNs** provisioned with object type as **HLR**, then proceeds to step 17; else goes to Step 11.
4. Checks if the message is a **MO** Forward Short Message (**MO FSM**). If so, it continues to step 5; else go to step 11.
5. Checks if **PPSMS** feature is **ON**. If so, goes to step 12; else continues with Step 6.
6. Checks if **MNPSMS** feature is **ON**. If so, continues to step 7; else goes to step 11.
7. The originating subscriber's Mobile Subscriber **Integrated Services Digital Network** (**MSISDN**) number (i.e. phone number) is used to search the G-Port Mobile Number Portability database. If **MSISDN** Number is found in the **PDB/DN** table, continue to step 8; else goes to step 11.

8. Checks the portability type of the subscriber. If it matches "Ported-out/ Not Known/ **FNPTFN**" then continues to step 9. If portability type is "Prepaid-1/Prepaid-2," goes to step 11.
9. Uses **SCCP CdPA** Address to search the list of "home network" **SMSC** addresses. If a match is found, indicating the ported-out subscriber is fraudulently attempting to send **SMS** using the old network's **SMSC**, then continues to step 10; else goes to step 11.
10. The message will be discarded, **UIM #1129** is printed, and an error message generated and returned to the originating **MSC**. Go to Step 19.
11. It's a fall-through case. Continue with Normal **GTT** processing: go to step 19.
12. Checks if message is from one of the **IN** Platforms (**PPSMS** Servers). If so, goes to step 18; else continues with step 13.
13. The originating subscriber's Mobile Subscriber **Integrated Services Digital Network (MSISDN)** number (i.e. phone number) is used to search the **G-Port** Mobile Number Portability database. If **MSISDN** Number is found in the **PDB/DN** table, continue to step 14; else go to step 11.
14. Checks the portability type of the subscriber. If it matches "Prepaid1/Prepaid2," go to step 18; else continue with step 15.
15. If the subscriber portability type is "Ported out / **FNPTFN**/ Not Known" and **MNP SMS** feature is also **ON**, goes to step 9; else goes to step 11.
16. Exits from **MNP SMS** feature functionality and continues with existing processing for other services or **GTT**.
17. Exits from **MNP SMS** feature functionality and continues with existing processing for **GPORT**.
18. Exits from **MNP SMS** feature functionality and continues with existing processing for **PPSMS**.
19. Exits **MNP SMS** feature functionality.

The following figure illustrates these functions.

Figure 5-2 Flowchart of MNP SMS Functions

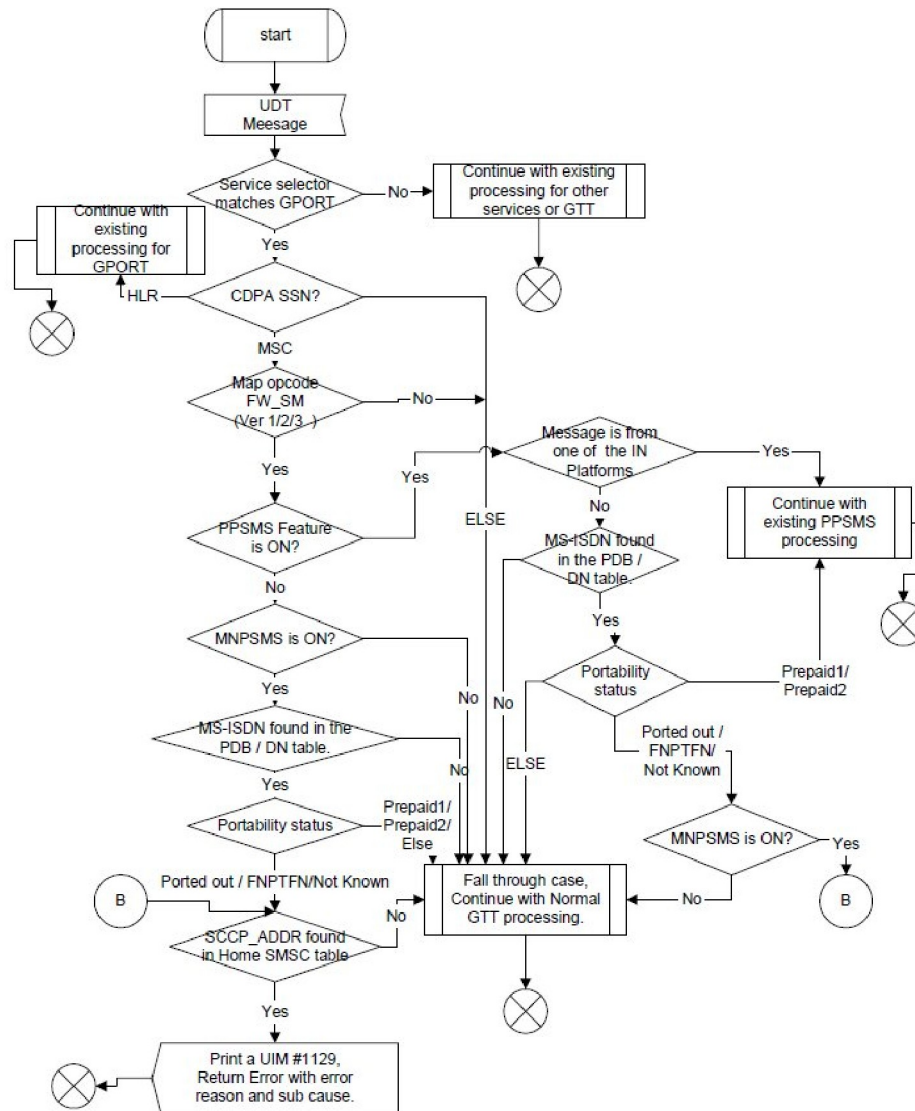

Hardware Requirements

No new hardware is needed to support this feature.

5.12 Pre-LNP Query Service GTT processing (Release 43.0)

The Pre-LNP Query Service GTT processing feature allows Global Title Translation (GTT) to be performed on messages before the messages are processed by the LNP local subsystem.

GTT is used to determine whether the originator of the query has an agreement with the LNP service provider to perform LNP database lookup. If an agreement exists, then LNP service processing is performed and an appropriate response is sent to the originator. If an agreement does not exist, then the query is routed as per the GTT result.

This functionality is available for LNP Query Services (AIN, IN, LRNQT, LNPQS, PCS, and WNP).

5.12.1 Feature Control Requirements

The EGTT feature must be turned on before the Pre-LNP Query Service GTT processing functionality can be provisioned.

5.12.2 Hardware Requirements

The Pre-LNP Query Service GTT processing functionality requires an E5-SM4G or higher card.

5.13 Prepaid IDP Query Relay Enhanced

The Prepaid IDP Query Relay feature has been enhanced to support the route on SSN message with GTI=0 for true point code as well as MTP routed messages. For messages with GTI=0, CSL screening has been done on OPC/DPC instead of the screening based on CDPA GTA. A new list type OPCDPC has been defined in the CSL table. The OPC/DPC parameters are supported in the CSL commands (ent/dlt-csl) for new list type OPCDPC for the IDP Relay feature.

The dlt/ent/rtrv-csl and the dlt/ent/rtrv-srvsel commands were updated to support this enhancement.

See *Prepaid IDP Query Relay Feature* in *IDP-Related Features User's Guide* for more information.

5.14 Prepaid IDP Query Relay (IDP Relay) Service Portability (Release 41.1)

Service Portability support for the IDP Relay feature allows the CDPNNP Service Action to recognize own network IS41 and GSM subscribers. When Service Portability is applicable, the GRN digits can be used during execution of the Formatting Actions for the NPP rule.

SPFILL and RNSPFILL

The SPFILL and RNSPFILL configuration options are introduced for the IDP Relay feature.

The SPFILL option controls the behavior of the CDPNNP and CGPNNP Numbering Plan Processor (**NPP**) Service Action Handlers in the use of RTDB SP digits. The option indicates whether SP digits are used if Default RN or GRN is used for local subscribers. This option allows use of these Service Action Handlers in NPP rules containing a Formatting Action set that includes both RN and SP.

The RNSPFILL option controls the behavior of the CDPNNP and CGPNNP Service Action Handlers in the use of RTDB RN or SP digits. The option indicates whether SP digits are set to the value of the RN entity digits or the RN digits are set to the value of the SP entity digits, according to the NPTYPE and Default RN option values.

5.15 Prepaid Initial Detection Point Query Relay (Release 34.1)

Description

The purpose of the Prepaid Initial Detection Point (**IDP**) Query Relay feature is to provide a mechanism to insure that prepaid subscribers are accurately charged for their calls in a portability environment.

This feature allows the EAGLE 5 ISS to intercept the **SCP** number portability database query from the **MSC**, perform the portability check on the called number, insert the portability information (i.e. Routing Number or **HLR** Address), and forward the **IDP** query to a prepaid **SCP** for processing. When the **SCP** receives the **IDP** query, it will have all of the information it needs to accurately charge for and process the call.

For message discrimination on **DSM** cards, the **IDP** Relay feature uses the service selector (**SRVSEL**) framework already present in the EAGLE 5 ISS..

Not all messages for the **IDP** Relay service will have their outgoing **TCAP DN** conditioned.

The **IDP** Relay feature performs the following filters and checks on the intercepted messages to verify that the:

- Service selected is the **IDP** Relay (:**srvsel=idpr**) service.
- **MSU** has the **ITU TCAP** package
- **MSU** opcode = **IDP**
- **SCCP/TCAP/INAP** are successfully decoded
- **SK** and event **BCSM** parameters are present and decoded correctly
- **CDPN** or **CDPN (BCD)** parameter is present and decoded correctly
- **SCCP CDPA** exists in the common screening **GTA** list for the **IDP** Relay feature
- **SK+BCSM** exists in the common screening **SKBCSM** list for the **IDP** Relay feature
- Number condition of the **TCAP** is successful based on Table *ID Relay Number Conditioning*..
- Conditioned **TCAP DN** prefix match exists in the common screening **CCNDC** list for the **IDP** Relay feature.
- Prefixnum=4 in the Prefix table and , the **SCCP CGPA** is checked for a default country code (**DEFCC**) match.
- Conditioned **TCAP DN** is found in the **RTDB** single/ Range table with either an **SP** or **RN** entity type.
- Based on the Prefixnum=1, 2, 3, the outgoing **TCAP DN** is conditioned. See for more details.
- The message is forwarded to the **GTT** handling based on the original incoming **SCCP CDPA**.

Table *IDP Relay Number Conditioning* shows the number conditioning performed on the incoming **TCAP DN** for the **IDP** Relay feature.

Table 5-3 IDP Relay Number Conditioning

Incoming Address			Number Conditioning	Outgoing Address	
TCAP DN NAI	Perform SCCP CGPA DEFCC Check?	TCAP DN Format		NAI	Format
International	No	<CC><DN>	None Do RTDB Lookup	If PFX3 =unknown NAI =unknown Else NAI =International	<PFX1><CC> <RN><DN>
National	If PFX4 =On	<DN>	Add DEFCC Do RTDB Lookup	If PFX3 -unknown NAI =unknown Else NAI =National	<PFX2><RN> <DN>
Unknown	No	<IEC><CC> > <DN>	CSL Delete prefix found, (P1=International), remove it Do RTCB Lookup	NAI =unknown	<IEC><CC><RN><DN>
Unknown	If PFX4 =On	<NEC><DN> >	CSL delete prefix found, (P1=International), remove it Do RTCB Lookup	NAI =unknown	<NEC><RN><DN>
Unknown	If PFX4 =On	<DN>	No CSL delete prefix found, ADD DEFCC Do RTDB Lookup	NAI =unknown	<RN><DN>



Note:

See the Glossary for a list of terms and acronyms used throughout this document.

Common Screening List

Common Screening Lists are used for screening messages in various features. The **IDP** Relay feature can screen up to 4 Common Screening Lists.

The **Common Screening List** lists supported by this command are not considered part of **Gateway Screening** or **GSM MAP** Screening.

One or more Common Screening Lists may be associated with a particular feature. Table Summary of CSL-supported Features. lists each supported feature, the associated screening list names, and other details about the entries that are supported.

Table 5-4 Summary of CSL Supported Features

Feature Name	Screening List Name	Card Type	Parameter	Maximum Number of Entries	Range of Values
Prepaid IDP Query Relay	GT	DSM	DS	50	1 to 15 digits [0-9, a-f, A-F] or none
Prepaid IDP Query Relay	CCNDC	DSM	DS	20	1 to 6 digits [0-9, a-f, A-F] or none
Prepaid IDP Query Relay	SKBCSM	DSM	DS	25	4 digits [0-9, a-f, A-F] or none
Prepaid IDP Query Relay	DELPFX	DSM	DS	10	1 to 5 digits [0-9, a-f, A-F] or none
Prepaid IDP Query Relay	DELPFX	DSM	P1 (National / International)	10	1 digit [0-1], where: 0:= National , 1:= International

Hardware Requirements

The **IDP Relay** feature cannot be enabled if Application Services Module (**ASM**) cards or **TSM** cards are in the system, or if **SCCP** gpls are entered in the system.

The **IDP Relay** feature runs on the **VSCCP** gpl with **DSM** cards connected to the **EPAP**. **VSCCP** GPLs can also be entered once the feature is enabled.

Limitations

The **GTT** feature must be on before the **IDP RELAY** feature can be enabled.

The **IDP RELAY** feature and the **LNP** feature cannot be enabled at the same time in the system.

The **IDP RELAY** feature cannot be enabled if **ASM** or **TSM** cards running the **SCCP** application are present in the system.

5.16 Prepaid SMS Intercept - Phase 1 (Release 28.1)

Mobile operators offering prepaid short message service (**SMS**) need an efficient way to perform credit checks on the subscriber sending the message, prior to allowing the message to be delivered. Intelligent network (**IN**) databases are generally used to perform the actual credit check. However, these databases can become overloaded if messages are sent to them for evaluation unnecessarily. An example of such a case is when all short messages, including those from or to contract (postpaid) subscribers, are sent to the **IN** platform for evaluation. The messages from contract subscribers do not need a credit check; thus this is additional traffic the **IN** platform must process unnecessarily.

Therefore, additional filtering and screening is needed in the **SS7** network to provide a finer granularity in determining which messages actually need to be sent to the **IN** platform, and which may simply be routed to the **SMSC**.

The Prepaid **SMS** Intercept - Phase 1 feature screens incoming messages from **MSC** based on **MAP** operation code. If the op-code indicates the message is a **MAP_MO_FORWARD_SHORT_MESSAGE (MO_FSM)**, the sender's **MSISDN** is retrieved and a database lookup performed. If the **MSISDN** belongs to a contract subscriber, the message will be routed to the **SMSC**. If the **MSISDN** belongs to a prepaid subscriber, the message will be diverted to a third-party **IN** platform for a credit check before allowing the message to be delivered to the **SMSC**.

The **MAP_FORWARD_SHORT_MESSAGE**, referred to as **FSM** in this document, is a message used to carry a text message (i.e. the "short message") being transmitted from the mobile handset of one subscriber to the mobile handset of another subscriber. In practice, the short message is delivered first to the Short Message Service Center (**SMSC**) of the sending subscriber. The **SMSC** is then responsible for sending the short message to the intended recipient. In **MAP** versions 1 and 2, the **FSM** message is used for both legs of the delivery. In **MAP** version 3, a **MO_FSM** (mobile originated) message is used to deliver the message from the sender to the **SMSC**, and a **MT_FSM** (mobile terminated) message is used to deliver the message from the **SMSC** to the recipient.

Refer to the *Feature Manual - G-Port* for current details on this feature.

Hardware Requirements

No new hardware is needed to support this feature.

5.17 Prevention of Congestion from Rerouted Traffic (Release 21.0)

When the status of the route is changed to allowed (when the route was restricted) or restricted (when the route was prohibited), a burst of rerouted traffic can occur on that route, thus congesting the route. To help keep this from happening, the **EAGLE** in Release 21.0 can control the rate that it broadcasts **TFR** and **TFA** messages to adjacent signaling points. This can regulate the amount of traffic the adjacent signaling points can send to the **EAGLE** when the route becomes allowed or restricted.

The rate that the **EAGLE** sends the **TFR** and **TFA** messages, (the pacing rate), can be configured with the `tfatfrpr` parameter of the `chg-stpopts` command. The value of the `tfatfrpr` parameter is from 0 to 1 second and can be set in 0.1 second intervals. The default value for the `tfatfrpr` parameter is 1 second. A value of 0 for the `tfatfrpr` parameter indicates that the pacing should stop. The pacing of **TFR/TCR** is stopped and all remaining **TFR/TCR** are broadcast at once if the current alternate route used to route traffic to the affected point code is in danger of congestion.

The **TFA/TCA** and **TFR/TCR** for each affected point code are sent in groups of 20%. For each time period defined by the pacing rate, 20% of the messages that are to be sent to the adjacent signaling points are broadcast to those signaling points.

This feature is applicable only for **ANSI** signaling links. The pacing is not done towards **ITU** networks.

If the destination becomes inaccessible or accessible before all of the **TFR/TCR** messages are broadcast, then the remaining **TFR/TCR** messages are not sent.

TFA/TFC messages for multiple affected destinations are sent in parallel.

The pacing of **TFR/TCR** messages is stopped and all remaining **TFR/TCR** messages are broadcast at once if the current alternate route used to route traffic to the affected point code is in danger of congestion.

The broadcast of **TFA/TFR** messages sent about X.25 pseudo point codes is controlled by this feature.

5.18 Prevention of Link Oscillation (Release 21.0)

A variety of network problems can cause signaling links to oscillate in and out of service causing frequent changeovers and changebacks and excessive network management message generation. If many links simultaneously oscillate, congestion can occur. When the **EAGLE** begins restoring an out of service signaling link, the **EAGLE** starts the level 3 T32. If the signaling link fails again before the level 3 T32 expires, the **EAGLE** does not attempt to bring the signaling link into service until the level 3 T32 timer expires. When the level 3 T32 timer expires, the **EAGLE** attempts to restore the signaling link into service.

The value of the level 3 T32 timer is set with the `chg-13t` command. The range of values for the level 3 T32 timer is from 60 seconds to 120 seconds. The default value for the level 3 T32 timer is 60 seconds.

The link alignment procedures are not delayed under the following conditions:

1. When a signaling link is manually taken out of service using the `dact-slk` command, the level 3 T32 timer is stopped (if it is running).
2. When the signaling link is brought back into service using the `act-slk` command.
3. When a new signaling link is first aligned.

The level 3 T32 timer can only be assigned to **ANSI SS7** linksets and signaling links.

5.19 Preventive Cyclic Retransmission (PCR) (Release 20.0)

Preventive cyclic retransmission is one of the two forms of error correction for the **SS7** protocol. Basic error correction is the other. Preventive cyclic retransmission is a forward error correction scheme that uses positive acknowledgments to support the forward error correction. Negative acknowledgments are not used for retransmission. **PCR** is used when the one-way delay on a link is greater than or equal to 15 milliseconds. A typical example is a satellite link.

Each message signal unit transmitted is retained at the transmitting end of the signaling link. Copies of that **MSU** are transmitted to the receiving end of the signaling link until the transmitting end of the signaling link receives a positive acknowledgment from the receiving end that it has received a good **MSU**. When the transmitting end of the signaling link has received the positive acknowledgment, the **MSU** it has retained is discarded.

The **PCR** feature should be used in the following circumstances:

- When the one-way propagation delay on a signaling link is greater than or equal to 15 milliseconds.
- When the signaling links are established via satellite.

The **PCR** feature has two modes of operation, normal retransmission and forced retransmission.

Normal Retransmission

The following rules apply to normal **PCR**:

1. If new **MSUs** are available, the new signal units are sent.
2. If new **MSUs** are available and retransmission is occurring, retransmission stops, and the new signal units are sent.
3. If no new **MSUs** are available to be transmitted, **MSUs** in the retransmission buffer are retransmitted cyclically.

For this example, assume the following:

1. There are only 3 new **MSUs** to be transmitted from **STP A** to **STP B**.
2. The transmission buffer is empty.
3. Both **STPs** are using **PCR** for error correction.

Figure 5-3 illustrates how normal **PCR** works.

Figure 5-3 Example of Normal Retransmission with PCR

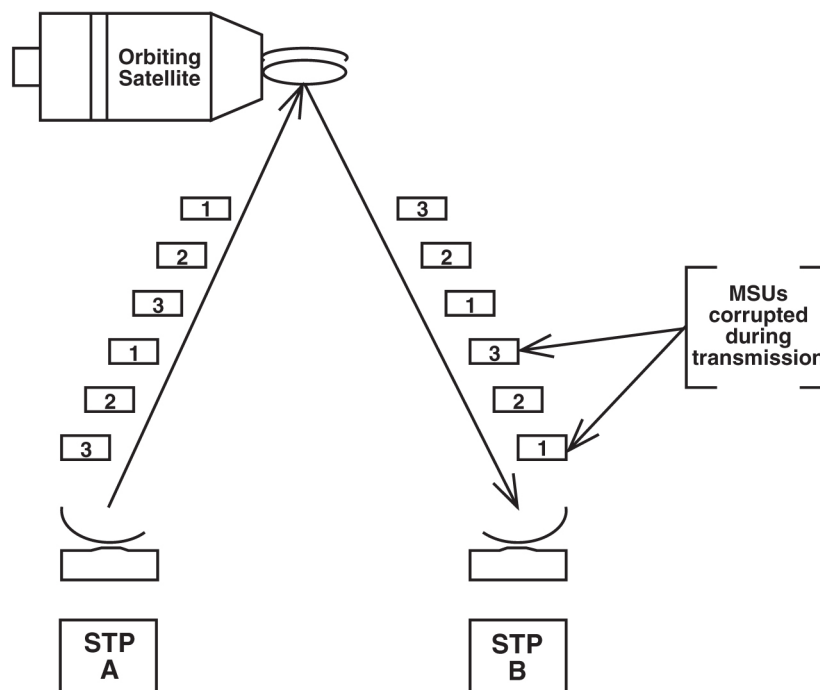

MSUs 1 through 3 are sent from **STP A** to **STP B** and are copied to the retransmission buffer. During transmission, packets 1 and 3 are corrupted before reaching the remote **STP B**.

STP A knows to retransmit the **MSUs** in the retransmission buffer since no new **MSUs** are available. Figure 5-3 shows several more copies of packets 1 through 3 are retransmitted.

On the receiving side, **STP B** receives the corrupt **MSUs** and discards them. Since **PCR** is used, **STP B** does not send a negative acknowledgment to **STP A**. **STP B** knows that more copies of the packets are arriving.

Under normal conditions, when no message signal units are to be transmitted or cyclically retransmitted, **FISUs** are sent. In some particular cases, **LSSUs**, continuous **FISUs** or flags may be sent.

Example of Basic Error Correction vs. PCR

Figure 5-4 illustrates how **PCR** outperforms basic error correction when a link experiences a long transmission delay. Assume the delay between the **EAGLE** and the **SSP** is 1 second for both basic error correction and **PCR**. The **MSU** size is 50 octets, and the transmission speed is 64 Kbps.

Examine the Basic Error Correction side of the figure. An **MSU** is sent from the **EAGLE** to the **SSP**.

During transmission, the **MSU** is corrupted. The **EAGLE** is notified two seconds later that it needs to retransmit the signal unit. Another second later, the valid **MSU** is received by the **SSP**. The total amount of time is 3 seconds.

Examine the **PCR** side of Figure 5-4. An **MSU** is sent from the **EAGLE** to the **SSP**. During transmission, the **MSU** is corrupted. Since **PCR** error correction is used, a negative acknowledgment is not sent. The receiving end knows that another copy is coming. The corrupted **MSU** arrives at the **SSP** in 1 second, and the valid **MSU** arrives 0.00625 seconds later. The total time is 1.00625 seconds. This formula is used to calculate the time interval between the first **MSU**'s arrival and the second **MSU**'s arrival.

$$\frac{8 \text{ bits}}{1 \text{ octet}} \times \frac{1 \text{ second}}{64000 \text{ bits}} \times 50 \text{ octets} = .00625 \text{ seconds to generate another MSU}$$

Figure 5-4 Basic Error Correction vs. PCR

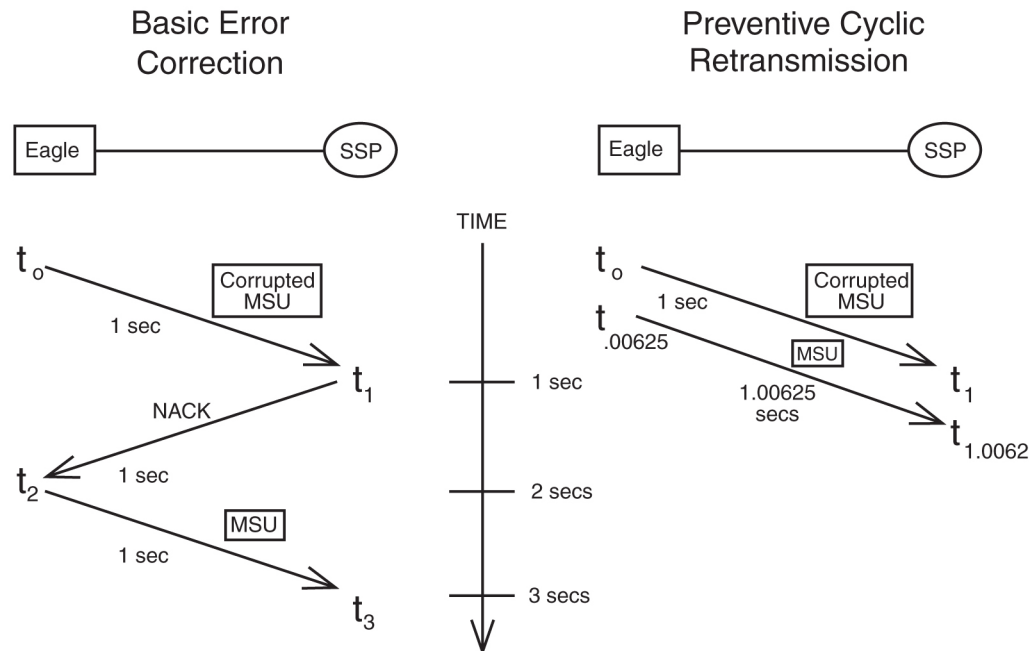

Forced Retransmission

To complement preventive cyclic retransmission, the message signal units available for retransmission are retransmitted with priority when a threshold of outstanding **MSUs** or a threshold of the number of message signal unit octets available for retransmission has been reached. This is forced retransmission.

With **PCR**, two thresholds are continuously monitored. These thresholds are the number of message signal units available for retransmission, N_1 , and the number of message signal unit octets available for retransmission, N_2 .

If the N_1 or N_2 value reaches its threshold, no new message signal units or fill-in signal units are sent, and forced retransmission begins. **MSUs** in the retransmission buffer are sent in the same order that they were originally transmitted. Retransmission continues until all of **MSUs** have been retransmitted.

 **Note:**

All **MSUs** are sent even if acknowledgments are received during forced retransmission. After all **MSUs** have been retransmitted, acknowledgments, if any, are processed, and the N_1 and N_2 thresholds are re-evaluated.

If both the N_1 and N_2 values are below the their respective thresholds, the normal **PCR** procedure can be resumed.

However, if the N_1 or N_2 value is still at its threshold, forced retransmission continues.

Example of Forced Retransmission

The following example shows how forced retransmission occurs. For this example, 5 **MSUs** are transmitted. Assume the N_1 threshold is 3, and N_2 is 3800 octets. The average **MSU** size is 50 octets.

[Figure 5-5](#) shows that the **EAGLE** begins transmitting **MSUs** to the **SSP** and copying **MSUs** to the retransmission buffer.

Figure 5-5 Example of Forced Retransmission

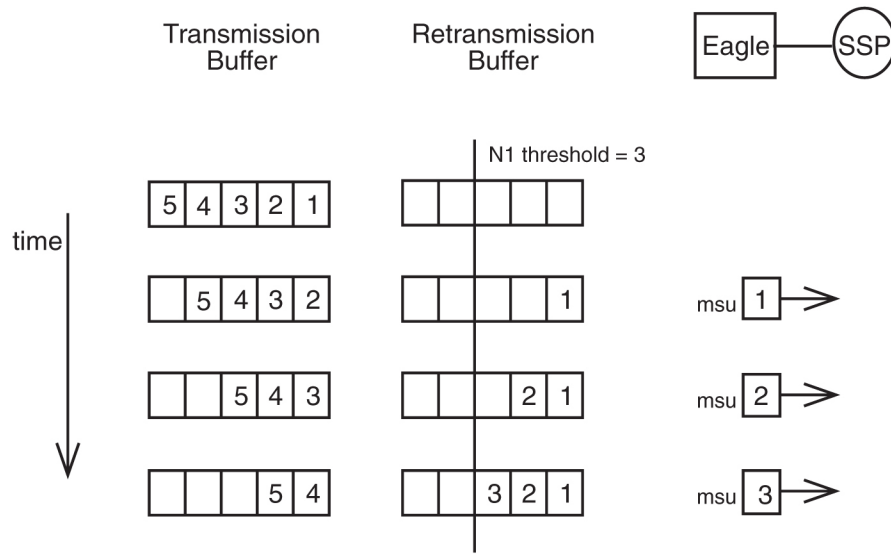

At this point, the threshold for unacknowledged **MSUs** in the retransmission buffer, N_1 has been reached.

Figure 5-6 shows forced retransmission beginning and continuing until all **MSUs** in the retransmission buffer have been retransmitted.

Figure 5-6 Example of Forced Retransmission – All MSUs Retransmitted

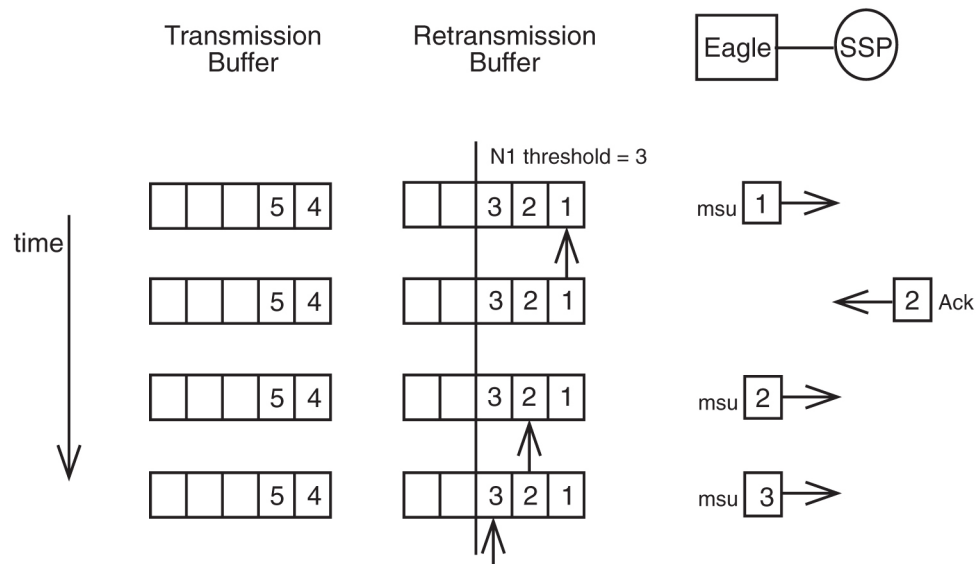

An acknowledgment for **MSUs** 1 and 2 comes in before 2 is retransmitted. This does not affect the retransmission of **MSU** 2. Forced retransmission dictates that all signal units in the retransmission buffer are retransmitted.

After all **MSUs** have been retransmitted, N_1 and N_2 are re-evaluated. In this case, acknowledgments for **MSUs** 1 and 2 have been received; thus, N_1 has been reduced and normal **PCR** resumes. Figure 5-7 shows the new **MSUs** in the transmission buffer being sent.

Figure 5-7 Example of Forced Retransmission – New MSUs Sent

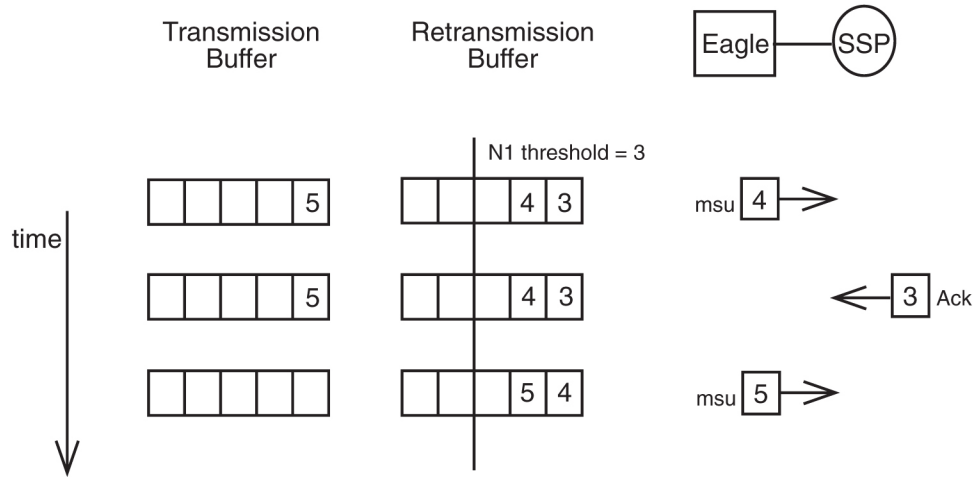

Derivations for N_1 and N_2

The user is responsible for setting the values for N_1 and N_2 . The following rules serve as a guide for determining these thresholds.

- N_1 is limited by the maximum numbering capacity of the forward sequence number range which dictates that not more than 127 **MSUs** can be available for retransmission on 56 Kbps or 64 Kbps signaling links.
- N_2 , in the absence of errors, is limited by the signaling link loop delay, T_L . The value of N_2 must ensure that not more than $T_L/T_{eb} + 1$ **MSU** octets are available for retransmission.
- T_L is the signaling loop delay, that is, the time between the sending of a message signal unit and the reception of the acknowledgment for this message signal unit in undisturbed operation (see Figure 5-8).

Figure 5-8 Determining Value of Signaling Link Loop Delay Timer (T_L)

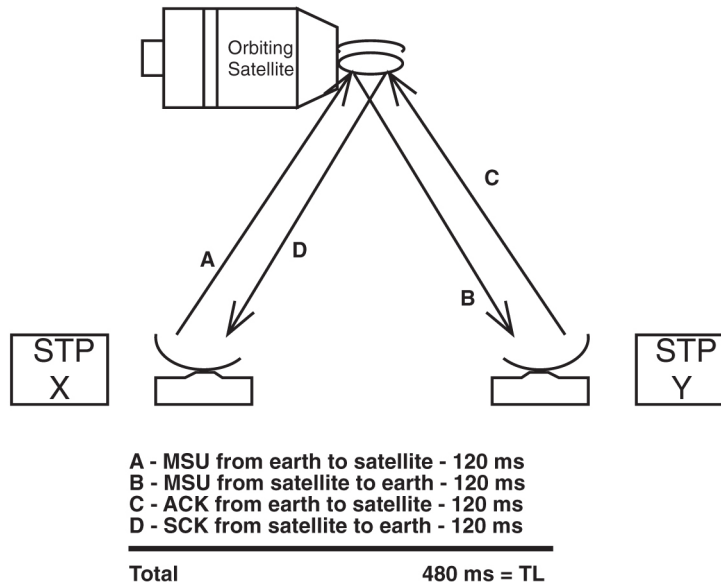

Assume that $T_L = 480$ milliseconds or 0.480 seconds. This value is based on a satellite located 22,300 miles above the earth and the signal propagating at a rate of 186,000 miles per second. A minimum of 120 milliseconds are required for a signal to reach a satellite from earth.

- T_{eb} is the emission time of one octet
- Default value for $N_1 = 76$ outstanding **MSUS**
- Default value for $N_2 = 3800$ octets

Table 5-5 Limitations for Various Line Speeds

Channel Speed	$T_{eb} = 1 \text{ octet} / \text{channel speed}$	$(T_L / T_{eb}) + 1$ rounded to nearest hundred, $T_L = .480 \text{ seconds}$
64 Kbps	1.25×10^{-4} seconds	~3800 octets
56 Kbps	1.43×10^{-4} seconds	~3400 octets
38.4 Kbps	2.08×10^{-4} seconds	~2300 octets
19.2 Kbps	4.17×10^{-4} seconds	~1200 octets
9.6 Kbps	8.33×10^{-4} seconds	~600 octets
4.8 Kbps	1.67×10^{-3} seconds	~300 octets
2.4 Kbps	3.33×10^{-3} seconds	~100 octets

The calculations for the default values assume an average **MSU** of 50 octets.

Default N_1 calculation:

$N_1 = 3800$ octets from table above / 50 octets from average **MSU** = 76 outstanding **MSUS**

Default N_2 calculation:

$N_2 = T_L / T_{eb} + 1 = 3800$ octets from table above for 64Kbps signaling link.

5.20 Priority Processing of Network Management Messages (Release 21.0)

Some of the new protocol features like cluster routing and diversity management have increased the processing complexity of network management functions. Under large failure conditions, it is possible that too many network management functions need to be performed, causing an application processor overload. In the releases prior to release 21.0, if such a condition was encountered, the **EAGLE** discarded the network management messages regardless of what kind of network management message they were. This method of handling network management messages may have an impact on the network's recovering capability under large scale failure conditions when several critical network management functions must be performed.

This feature provides the capability to prioritize the network management functions to make sure that critical network management functions receive high processing priority under such overload conditions.

During normal operation, the network management functions are processed with equal priority, but the **EAGLE** closely monitors for excessive unexpected events which may result in an application processor overload. The prioritizing of network management functions is triggered when the application processor overload is experienced on any **LIM**.

For this feature, the **EAGLE** collects one measurement, Network Management Messages Discarded due to Network Management Overloading. This measurement collects the number of network management messages discarded when the network management processor overload condition has been reached. Measurements are collected for discarded network management messages at each priority level. This measurement is collected for each signaling link in the system.

The **EAGLE** generates the following **UAMs**:

UAMs

- **UAM 304 - Network Management Task Priority Discard Threshold Reached (REPT-NMTSK-DSCD)** — a minor alarm generated when a network management message is discarded because the application processor of a **LIM** is overloaded.
- **UAM 305 - Recovery from Network Management Task Priority Discard Processing (RECVY-NMTSK-DSCD)** — generated when the network management overload condition is cleared.

This feature is applicable only for the **ANSI** network. Network Management events triggered due to change in status of **ITU** network elements (links, routes, linksets, destination) are processed on first come first served basis.

5.21 Private Point Code (Releases 31.12, 34.0)

Private point codes (**PPCs**) are used for internal routing within the **EAGLE**. **PPCs** may be used for "internal point codes" which are used for the End Office feature, and adjacent point codes for **IPGWx** linksets. The principle difference between private point codes and non-private is whether the point code is known outside the **EAGLE**. Point codes within the **EAGLE** are useful for routing messages within the **EAGLE**, but when these point codes are non-private, they consume a point code value in the

network. By making these point codes private, it is possible to have a point code value indicated as private and still have the same point code value (as not private) available for network configuration.

PPCs must be supported in every supported domain. **ANSI**, **ITU-I**, **ITU-N**, **ITUI-Spare**, **ITUN-Spare**, **ITUN24** must all support a private version of a point code.

PPCs will be allowed for **IPGWx APCs** (adjacent point codes). Currently there are special rules for provisioning **IPGWx APCs**. A special parameter **IPGWAPC=YES** on the **ent-dstn** and **ent-ls** commands allows point codes with otherwise invalid ranges (e.g., **ANSI** point code 0-0-1) to be used. This parameter also identifies the linkset as one that may only contain **IPGWx** links. With the implementation of this feature, **PPCs** will also be allowed for this purpose. The **IPGWAPC** parameter will remain, however, since not all **PPCs** are **IPGWx APCs**.

PPCs will also be allowed for **SAPCs** on **IPGWx** linksets. Like **IPGWx APCs**, **SAPCs** on **IPGWx** linksets are not "real" point code, and the network beyond the **EAGLE** does not need to be aware of them.

PPCs will also be allowed used for the provisioning the End Office feature. In order to support this, **PPCs** must be allowed for the Remote Application (**RMT-APPL**) table, and **GTT** table, in addition to the **Destination** and **Route** tables.

Existing Internal Point Codes and **IPGW** linkset adjacent point codes will not be modified during upgrade. After upgrade, both private and non-private point codes can be used for these purposes.

Note that static routing keys are never needed for **RMT-APPL** point codes or **IPGWx** adjacent point codes. For the End Office feature, a true or secondary point code routing key is needed, while for **IPGWs** adjacent point codes, no routing key is needed.

Limitations

1. This feature does not allow the **EAGLE** to **MTP** convert between National and National Spare Point Codes. Likewise, this feature does not allow the **EAGLE** to **MTP** convert between International and International Spare Point Codes.
2. In the destination table, an **ITU-I** alias and an **ITU-I** Spare alias cannot be defined for the same **Point Code**, likewise an **ITU-N** alias and an **ITU-N** Spare alias cannot be defined for the same point code
3. The feature is not supported on the **SEAS** interface. Spare point codes are only supported for **ITU** point codes, and **SEAS** only supports **ANSI** point codes. Any Private **ANSI** point code provisioned using the standard **EAGLE** command line interface is not displayed by the **SEAS VFY-** command.
4. **ITU** National and **ITU** National **Spare Point Code** are implemented as separate network domains that can co-exist within the same **STP**.
5. Spare point codes are not supported for **IPGWI** sockets using **TALI** protocols. The spare point code feature may not be enabled if any application sockets have been provisioned on **IPGWI** cards.
6. The existing implementation of **Gateway Screening** does not support Group Code (Duplicate Point Codes). **Gateway Screening** will also not support **PPCs**.
7. The **Spare Point Code** and **PPC** prefix value, s- and p- do not apply to domain type point codes for **ANSI** and **ITU-N24**.

8. **ITU-N** and **ITU-N24** Point Codes cannot co-exist as **SID Destination** True Point Codes and therefore **ITU-N Spare** and **ITU-N24** Point Codes cannot coexist as **SID Destination** True Point Codes.
9. A single **STPOPTS** value (cnvcgdi) will be used to control message handling for **ITU-I** and **ITU-I Spare** messages when the **CgPA PC** does not have a required alias
10. A single **STPOPTS** value (cnvcgdn) will be used to control message handling for **ITU-N** and **ITU-N Spare** messages when the **CgPA PC** does not have a required alias
11. The existing implementation of the **SRVSEL** command interface to the **SRVSEL** table does not provide a way to separate **MSU** traffic for different **ITU** National Group Code networks. Therefore no provision is made for the **SRVSEL** command to control the separation of **ITU** spare and non-spare traffic. The **SRVSEL** table applies to the **EPAP** based features **G-FLEX**, **INP**, **G-PORT**, **SMS** Prepaid, and **IS-41** to **GSM** Migration. Likewise, no provision is made for the **GTTSEL** command interface to the **GTTSEL** table to allow separation of **ITU** spare and non-spare traffic for **EGTT**, **VGTT** and **MGTT**.

5.22 Prohibit Removing the Last Route to a Destination if that Destination is being Referenced by Mated Applications or Concerned Signaling Point Code Groups (Release 22.0)

In previous releases when a route was being removed from the database, the **EAGLE** checked to make sure other routes to the **DPC** were defined if the **DPC** of the route was being used by a global title translation. When this condition was detected, the **EAGLE** issued a message warning that the condition was present, but allowed the route to be removed from the database.

In release 22.0, a new rule has been added to the **EAGLE**'s `dlt-rte` command and the **SEASDLT-RTE** command function that does not allow the specified route to be removed from the database if this condition is present. If the user attempts to remove a route under this condition, the command is rejected. On an **EAGLE** terminal, this error message is displayed.

```
2356 Cmd Rej: Destination referenced by GTT cannot be delete
```

5.23 Prohibit the Assigning of a Linkset with Linkset Types A or E to a Cluster Route (Release 22.0)

In previous releases, a user could assign a cluster route to a linkset with a linkset type of either A, B, C, D, or E from both the **EAGLE** terminal and the **SEAS** interface. In release 22.0, the only linkset types that can be assigned to a cluster route are B, C, or D. The **EAGLE**'s `ent-rte` command and **SEAS ASGN-RTE** command function have been changed to allow only these linkset types to be assigned to cluster routes. If the user attempts to assign a cluster route to a linkset with a linkset type of either A or E,

the command is rejected. On an **EAGLE** terminal, the following error message is displayed.

```
E2349 Cmd Rej: Link Set Type invalid for Cluster Destination
```

5.24 Provide 2 HSL and 64 LSL on SLIC (Release 46.5)

This feature provides two (2) High-Speed Links (HSL) and 64 Low-Speed Links (LSL) on the card in order to support TDM links and increase card efficiency. This feature allows SLIC to replace the HC-MIM (same capacity in one card slot instead of two card slots) or to replace the E5-E1T1 (doubles the capacity).



Note:

Channel bridging is not supported on SLIC cards. Channel bridging for the location (if any) should be removed by the operator before hot swapping an HCMIM with a SLIC card.

5.24.1 Hardware

There are sixteen (16) LEDs, two for each E1/T1 port used to indicate port and channel (signaling link) status. One LED per E1/T1 port indicates the E1/T1 port status, and one LED per E1/T1 port indicates the aggregated channel status.

Table 5-6 HCMIM and SLIC-E1T1 LED Configuration

E1/T1 port Status LED	Aggregated Channel Status LED
Green (No alarms, port has acquired timing and framing synchronization)	Green (if all channels provisioned = ISNR)
Amber (Remote alarm condition)	Amber (indicates port is the "reflected" port in Channel Bridging mode of operation. Applies only to "even" numbered ports)
Amber blinking (Loss of Frame Synchronization)	Amber blinking (if any channels provisioned = OOS)
Red blinking (all other alarms)	Red blinking (if all channels provisioned = OOS)
Red (Port not provisioned)	Red (if no channels are provisioned)

5.25 Provisioning Database Interface (PDBI) Command Statistics (EPAP 13.0)

The PDBI Command Statistics feature provides the ability to monitor EPAP provisioning performance using reports. These reports are stated in commands per second. Reported statistics include information on provisioning patterns, degradation of performance, and performance impact due to various activities (maintenance related or not).

This feature generates reports for a period of time containing at least the following information:

- Average number of PDBI connections for the reported period

- Peak number of PDBI connections for the reported period
- Average system PDBI commands per second (CPS) for the reported period
- Peak system PDBI commands per second (CPS) for the reported period (calculated per second)
- Percentage of commands with a return code of zero that successfully updated the database for the reported period (ent/upd/dlt commands only).

Statistics related to numbers of PDBI connections are based on the number of PDBI connections at one time.

These reports is accessible via Command Line Interface (CLI) and GUI. PDBI statistics are kept for a specific period called the retention period. During the retention period, reports can be generated on-demand.

Report intervals:

- 5 minutes interval
- 1 hour interval
- 1 day interval - When the daily PSR type is generated, the statistical data for a 24 hour period is displayed in the report. Only daily boundary timings are considered for this purpose.

For this feature to work in the event of a PDBA Switchover, the feature must be ON for both PDBA systems (Active PDBA and Standby PDBA).

On T1200 AS, the PDBI Command Statistics Feature is ON by default. On T1000 AS, the PDBI Command Statistics Feature is OFF by default.

User Interface (EPAP GUI)

The EPAP GUI shall provide the following two new menu options for this feature:

1. PDBA --> List PDBI Connections
2. PDBA--> PDBI Statistics Report

PDBI Statistics Report

This feature will provide a new menu option “PDBA--> PDBI Statistics Reports” to enable EPAP GUI users to view available statistics reports.

Clicking this menu item will display a new screen in a browser’s right frame to view a statistics report. Select the report generation type and identify the time period for the report.

Click on the “Generate Report” button to display the report.

List PDBI Connections

This feature provides a new menu option “PDBA--> List PDBI Connections” to enable EPAP GUI users to view all provisioning connections to the PDBA. This GUI provides non-persistent data about PDBI and SOG connections along with some performance data based on the totals for the entire lifetime of each connection.

Upgrade Considerations

A new MySql database must be created to house PDBI statistical data on MPS-A servers during an upgrade or fresh install.

Limitations

PDBI statistical-data reports will be generated on-demand and are only available if the PDBI Command Statistics feature is ON. This feature is OFF by default, except on T1200 AS where it is ON by default.

This feature is not intended to provide the customer with an instantaneous (less than 1 second) performance rate. Dedicating too much processing power to keeping and calculating rates could be detrimental to performance. Additionally, performance rates calculated on too small of a time period could provide misleading information.

Peak CPS values in the PSR or listPDBIConns.pl output shall be displayed as whole number values (no fractional values or anything less than 1 CPS) since these are calculated with the reported number of commands that completed processing in a one-second time frame. A majority of commands under normal processing will take fractions of a second to perform. The average CPS values for larger time periods (minutes) will provide a much more accurate indication of system PDBI performance.

Due to current implementations, data in the EPAP pdba.cmd log, PDBI Statistics Report and List PDBI Connections may not match due to slight differences in the timestamps used to record a PDBI command. This discrepancy between a PDBI Statistics Report and List PDBI Connections might be most noticeable for a peak CPS on a system with a single provisioning stream.

This feature is not supported on non-provisionable EPAP systems. This feature is also not supported on B servers of a provisionable EPAP pair.

Note:

The Peak CPS reported in both the GUI PDBI Statistics Report and List PDBI Connections menus is not sustainable. It is provided for information purposes only. Customers should not expect to get this rate on a regular basis for any sustained period of time.

5.26 Provisioning Range for Gateway Screening (Release 22.0)

The values for certain parameters used to configure gateway screening can be entered as a range of values. Allowing a range of values for these parameters reduces the number of entries in the gateway screening tables required to support a particular configuration. The parameters whose values can be entered as a range of values are:

Parameters

- `ni` - the network identifier for an **ANSI** point code
- `nc` - the network cluster for an **ANSI** point code
- `ncm` - the network cluster member for an **ANSI** point code
- `pri` - the message priority in the **SIO** field of an **MSU**
- `h0` - the H0 heading code in the **SIF** field of an **MSU**
- `h1` - the H1 heading code in the **SIF** field of an **MSU**
- `type` - the translation type in the called party address field of an **MSU**

A range of values for these parameters can be specified for gateway screening commands entered on an **EAGLE** terminal or on the **SEAS** interface.

The range of values for a parameter is specified by the two values defining the range separated by two ampersands, &&. The value to the left of the ampersands must be less than the value to the right of the ampersands, for example, `:ni=002&&100`. In this example, the value of the `ni` parameter is all values from 002 to 100, including the values 002 and 100.

A range of values for an **ANSI** point code parameter can be specified with wildcards (*) or single values for other point code parameters. [Table 5-7](#) shows the valid combinations of these parameter values.

Table 5-7 Valid Value Combinations for ANSI Point Code Parameters

NI	NC	NCM
Single Value	Single Value	Single Value
Single Value	Single Value	Range of Values
Single Value	Single Value	Wildcard
Single Value	Range of Values	Wildcard
Single Value	Wildcard	Wildcard
Range of Values	Wildcard	Wildcard
Wildcard	Wildcard	Wildcard

A range of values for the `H0` and `H1` heading codes can be specified with wildcards (*) or single values for other heading code parameter. [Table 5-8](#) shows the valid combinations of these parameter values.

Table 5-8 Valid Value Combinations for H0 and H1 Parameters

H0	H1
Single Value	Single Value
Single Value	Range of Values
Single Value	Wildcard
Range of Values	Wildcard
Wildcard	Wildcard

When changing or removing an existing gateway screening entry, the **ANSI** point code values, priority values, `H0` and `H1` heading code values, or translation type values specified with the command must match the values configured in the database for the specified screening reference. If the specified parameter value in a specific screening reference is part of a range of values for that parameter already configured for that screening reference, the command is rejected.

For example, the database contains a gateway screening entry for the range of allowed **OPCs** 010-010-010 to 010-010-100 in **Allowed OPC** screening reference `opc1`. If an attempt is made to remove or change **Allowed OPC** screening reference `opc1` and the **ANSI** point code 010-010-025 is specified, the command is rejected because point code 010-010-025 is a part of the point code range configured in the database. To remove or change **Allowed OPC** screening reference `opc1`, these point

code parameters must be specified with the command, `ni=010,nc=010,ncm=010&&100`.

If the **ANSI** point code, priority value, H0 and H1 heading code values, or translation type values specified with an enter command is within the range of values already configured for the specified screening reference, the command is rejected. For example, the `ent-scr-opc` command is entered with the point code 010-010-050 assigned to screening reference `opc1`. If the database contains the range of point codes 010-010-010 to 010-010-100, specified as `ni=010,nc=010,ncm=010&&100`, the command is rejected. If the database contains an entry for all point codes with the network identifier of 010 and network cluster of 010, `ni=010,nc=010,ncm=*`, the command is rejected.

A range of values can be specified when displaying gateway screening entries. The range of values does not have to match the values configured in the database. The range of values specified with a retrieve command is used to limit the number of entries to search for. There are some restrictions for using **ANSI** point code values with retrieve commands. [Table 5-9](#) shows the valid combinations of the **ANSI** point code parameters.

Table 5-9 Valid Parameter Combinations for ANSI Point Code Parameters

NI	NC	NCM
Single value	Single value	Single value, a range of values, a wildcard, or NCM value not specified
Single value	A range of values, a wildcard, or the NC value is not specified	the NCM value is not specified
A range of NI values, a wildcard, or the NI value is not specified	the NC value is not specified	the NCM value is not specified

5.27 Proxy Point Code (Release 37.5)

The Proxy Point Code (**PPC**) feature allows the EAGLE 5 ISS to assume the point codes of other nodes. This ability provides seamless migration from direct connection between SS7 networks to connection through an EAGLE 5 ISS STP.

The PPC feature is used when an STP is first brought into a network. If an EAGLE 5 ISS is introduced into a network that directly connects to a separate or 'foreign' SS7 network, and if the PPC feature is enabled and turned on, then a user can specify the point code of the home network as a proxy point code, which is then assumed by the EAGLE 5 ISS.

After the point code is assumed, the SS7 node in the home network is connected to the EAGLE 5 ISS instead of directly connected to the SS7 node in the foreign network. The EAGLE 5 ISS provides routing connectivity in the home network to the foreign node and allows the foreign node to connect to the home network. The node in the foreign network continues to function as if it is connected to the original node in the home network.

The proxy point code is used as the originating point code for all EAGLE 5 ISS generated messages that are routed to the adjacent node of the linkset (referred to as the proxy linkset). The proxy point code can be reached by all nodes in the home network and can access all STP routing functionality in the foreign network. The EAGLE 5 ISS routes SS7 messages coming from the foreign network SS7 node into the home network based on the destination point code. A maximum of 100 point codes can be designated as proxy point codes.

 **Note:**

IPGWx linksets cannot be assigned a proxy point code as an adjacent point code: therefore, **M3UA** links and SUA links are excluded.

The proxy point code must be a full point code and can be any of the following network types:

- ANSI
- ITU-N
- ITU-I
- ITU-N Spare
- ITU-I Spare
- ITU-N24

5.27.1 Feature Control

The PPC feature has the following feature control requirements:

- The PPC feature is a quantity feature. The FAK that is used to enable the feature determines the maximum number of point codes that can be specified as proxy point codes. The allowed maximum ranges from 10 to 100, increasing in increments of 10. Each increment has a separate part number as shown:
 - 10: 893-0187-01
 - 20: 893-0187-02
 - 30: 893-0187-03
 - 40: 893-0187-04
 - 50: 893-0187-05
 - 60: 893-0187-06
 - 70: 893-0187-07
 - 80: 893-0187-08
 - 90: 893-0187-09
 - 100: 893-0187-10

A FAK for the part number corresponding to the desired quantity is required.

- The PPC feature is both enabled and turned on by the `enable-ctrl-feat` command. The `chg-ctrl-feat` command is not used.
- Once a feature quantity is entered, the quantity value cannot be decreased.
- After the feature is enabled and on, it cannot be turned off.
- A temporary FAK cannot be used to enable the feature.
- The Multiple Point Code (MPC) feature must be turned on at the EAGLE 5 ISS before the PPC feature can be enabled. It is not necessary for the MPC feature to be turned on at the adjacent node.

5.27.2 Hardware Requirements

The PPC feature does not have specific hardware requirements. However, the feature cannot be enabled if any of the following cards are present in the system:

- LIMDS0
- LIMV35
- LIMOCU
- ILA/EILA
- LIM-E1
- Dual-Slot DCM

If one of these cards is inserted after the feature is enabled, then the card will auto-inhibit.

5.27.3 Limitations

The PPC feature has the following limitations:

- Only 'A' link types are supported on a linkset using a proxy point code.
- Secondary adjacent point codes are not supported on a proxy linkset.
- M3UA links and SUA links are excluded for proxy point codes.
- If the routeset from the EAGLE 5 ISS to the proxy node is prohibited, then all links in any proxy linkset using the proxy point code are unavailable for traffic.
- If more than 50% of the links in the linkset are down, then congestion may occur.
- Only one linkset to an adjacent point code is supported by the EAGLE 5 ISS unless the Multiple Linksets to Single Adjacent PC feature is enabled and turned on.
- Configurations where the same proxy point code is a member of both the foreign and home networks are not supported.
- Global title translation (GTT) to a proxy node is not supported.

5.28 Quality of Service Enhancements (IP⁷ Release 3.0)

It is becoming necessary for networks to employ Quality of Service (QoS) techniques. QoS is a concept that allows elements of data transmission to be measured, improved, and, to some extent, predicted. As networks evolve, consideration must be given to guarantee acceptable levels of bandwidth, jitter, and latency for **IP** communication protocols, such as VoIP. The QoS enhancements added in release 3.0 provide the solution for these and other network communications parameters.

Quality of Service enhancements provide the ability to set the Type of Service (**TOS**) field in the IP packet header for QoS routing. This feature does not implement quality of service on its own. It does, however, provides the customer with the ability to set socket options, including the TOS field bits within the outgoing packet. Tekelec does not specify how the TOS bits should be set or interpreted. It is solely up to the customer to implement QoS using scheme best suited for them, by setting the TOS field bits.

TOS

The 8-bit TOS socket option is used to control the quality of service for network traffic. The intent of QoS is to route packets differently according to the TOS value. TOS is set on outgoing packets. The following sections describe the TOS bit field and give an example of a QoS model.

TOS Bit Field

Figure 5-10 describes the TOS bit field structure. The 8-bit TOS field resides in the IP header (Figure 5-9) and is used to identify different priorities/levels/interactions of service used by network routers, such as low-delay service. The TOS field within the outgoing datagram is set from values in the application socket's protocol control block (PCB). The TOS value defaults to 0 (normal service), since the PCB is initialized to zero. The TOS bits may be set to other values and read using the *setsockopt* and *getsockopt* system calls, which provide access to the TOS byte within the PCB.

Figure 5-9 IP Header Fields

4-bit version	4-bit header	8-bit TOS	16-bit total length (in bytes)	
16-bit authentication		3-bit flags	13-bit fragment offset	
8-bit TTL	8-bit protocol	16-bit header checksum		
32-bit source IP address				
32-bit destination IP address				

Figure 5-10 TOS Field

7	6	5	4	3	2	1	0
		Reliability	Throughput	Delay	IP precedence		

DS Bit Field

The first network QoS decoding scheme used the **TOS** bit field description (Figure 5-10). Another QoS decoding scheme is the **IETF** Differentiated Services (DiffServ) model. DiffServ renamed the TOS field to the **DS** field. Figure 5-11 describes the DS bit field structure. **DS** bits 0-5 are reserved for code points (**DSCP**). The upper two bits (**CU**) are currently unused. DiffServ code points are broken down into three pools, each pool representing the number of bits used within the DSCP field. Code pool 1, which provides 32 code points, is available for general use, while pools 2 and 3, providing 16 code points, are designated for experimental use only.

Figure 5-11 DS Field

7	6	5	4	3	2	1	0
CU		DSCP					

Figure 5-12 DiffServ Code Point Pool Table

Pool	Code Point Space	Use
1	Xxxxx0	Available
2	xxxx11	Experimental
3	xxxx01	Experimental

This feature allows the customer to modify the full 8-bit **TOS** socket option to control QoS. The customer is free to implement any QoS model that uses the 8-bit structure within the IP header **TOS/DS** bit fields.

Nagle's Algorithm

Nagle's algorithm is currently disabled for all **IP⁷** Secure Gateway sockets. So every message is transmitted via Ethernet as soon as possible. This means there is a one-**TCP**-packet-per-**MSU** relationship. This minimizes message latency, which is very important to Secure Gateway deployment in networks. While minimizing message latency, this mode of operation results in more packets, and therefore more **CPU** utilization processing packet headers, and also results in less efficient **LAN** utilization. When Nagle's algorithm is enabled, it allows the TCP/IP stack to hold onto messages for a period of time in an effort to pack multiple messages into a single TCP packet. At the expense of higher message latency, fewer packets are generated and processed, resulting in lower CPU utilization, and the fewer and larger packets result in more efficient LAN utilization. At high rates of traffic through a socket, message latency is minimal, since the threshold packet size is reached (messages fill the packet) very quickly, causing the stack to transmit the packet. At low rates of traffic, a stack timer governs how long a packet will be held prior to transmission. The application of Nagle's Algorithm only affects packet transmission and has no effect on the processing of received packets.

This feature allows the customer to enable or disable Nagle's algorithm. The socket option is defined as a 1-bit Boolean socket option; 1=Enable, 0=Disable.

Feature Implementation

[Figure 5-13](#) illustrates the overall design for implementing the QoS feature. The example shows how an application socket's **TOS** value can be changed using commands. The example also could be extended to cover modifying other socket options, including enabling/disabling of Nagle's algorithm. When an application socket is created, it is always assigned to **DCMPS** parameter set #10, containing the default socket options. Socket options may then be changed using one of the following commands:

chg-appl-sock

In [Figure 5-13](#), example 3, an application socket is changed to a different **DCMPS** parameter set. In this example the new **DCMPS** parameter set contains a different **TOS** value. This is accomplished by issuing the following admin command:

```
CHG-APPL-SOCK:SNAME=sockname:DCMPS=new_param_set
```

Changing an open socket to a different **DCMPS** set forces the socket to use the new **DCMPS** set's **TOS** value. This change occurs "on-the-fly." The socket does not need to be closed or inhibited. System call `setsockopt()` is invoked with the new **DCMPS** set **TOS**, thereby updating the affected socket's **PCB**.

chg-dcmpls

In [Figure 5-13](#), example 4, the **DCMPS** parameter set's **TOS** parameter is changed to a different value. This causes all sockets using the modified **DCMPS** parameter set to use the new **TOS** value. This is accomplished by issuing the following admin command:

```
CHG-DCMPS:SET=setnum:PARAM=1:PVALUE=new_tos_value
```

Changing the **TOS** parameter within a **DCMPS** set forces all existing sockets using that **DCMPS** set to use the new **TOS** value. For all open sockets, this change occurs "on-the-fly."

System call `setsockopt()` is invoked for all sockets using the modified DCMP5 set, updating the socket's **PCB** with the new TOS.

Only sockets affected using the above administration commands allow their socket options to be updated/changed.

Figure 5-13 ToS Setup

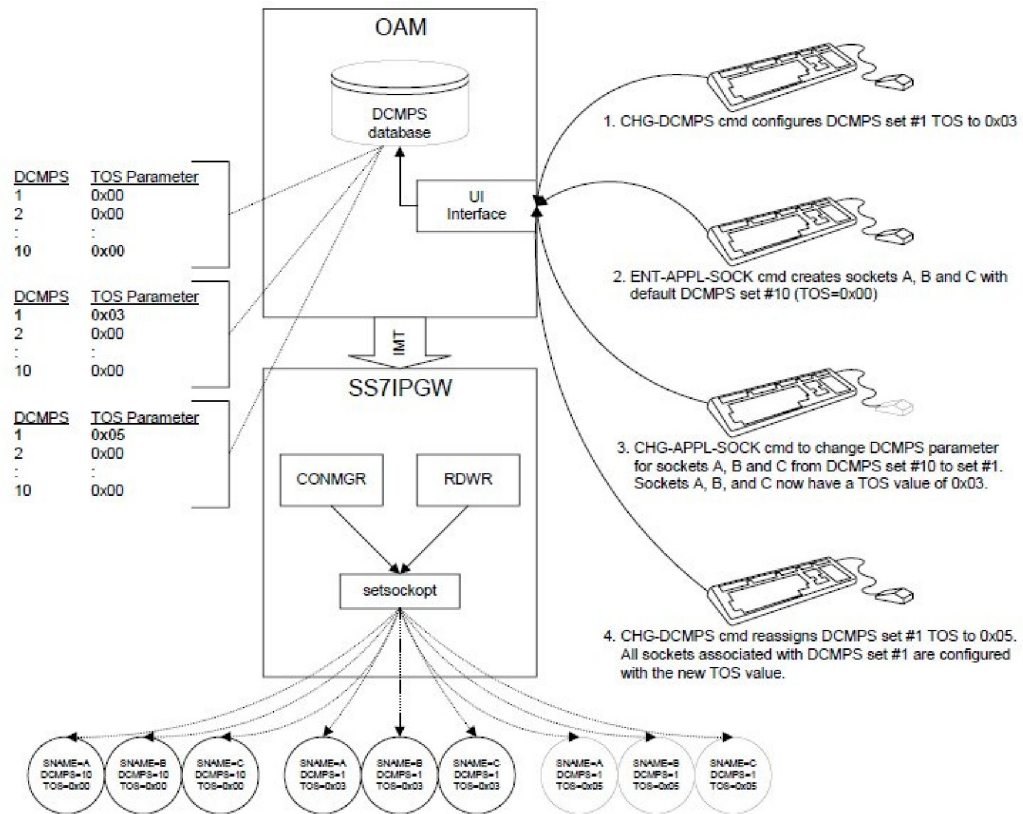

5.29 Random SLS Generation (Release 28.0)

The Random **SLS** Generation feature allows operators to overcome some of the **ITU** protocol limitations by ignoring the **SLS** value in the incoming **SS7** message when selecting an outgoing link for the message. This is accomplished by generating a new 8-bit **SLS** value that is used internally by the **EAGLE** to randomly select an outgoing link to the destination.

This feature does not alter the **SLS** value in the outgoing message; it is the **SLS** value received in the message. The newly-generated **SLS** is used for link selection only.

5.30 Remote Backup (Release 39.2)

The Remote Backup feature allows the database to be saved to and restored from a remote server, using FTP. If the **EAGLE** OA&M IP Security feature is turned on, then Secure FTP is used for data backup.

For a database backup, the **EAGLE** 5 ISS packs and compresses all files in a TAR file before transferring to a remote server. For a database restore, the **EAGLE** 5 ISS

unpacks and uncompresses the files and places the files on the active partition group of the TDMs.

5.30.1 Feature Control Requirements

There are no feature control requirements identified for this feature.

5.30.2 Hardware Requirements

The Remote Backup feature requires E5-IPSM cards.

5.30.3 Limitations

No limitations are associated with this feature.

5.31 Remote Upgrade Download (Release 39.2)

The Remote Upgrade Download feature allows new software to be downloaded to the EAGLE 5 ISS from a remote server, using FTP. If the EAGLE OA&M IP Security feature is turned on, then Secure FTP is used for data transfer.

The EAGLE 5 ISS downloads software by downloading a single TAR file that contains compressed files associated with the software release. The EAGLE 5 ISS unpacks and uncompresses all files of a software release and places them on the inactive partition of the **TDMs**. A remote server must be set up within the customer network to support data transfer to the EAGLE 5 ISS.

5.31.1 Feature Control Requirements

There are no feature control requirements identified for this feature.

5.31.2 Hardware Requirements

The Remote Upgrade Download feature requires E5-IPSM cards.

5.31.3 Limitations

No limitations are associated with this feature.

5.32 REPT-STAT-CLK Enhancements for Clocking (Release 28.2)

Description

This feature implements the following enhancements:

- New "mode=full" parameter and report. This report prints out a list of cards that are presenting with a clock failure.

 **Note:**

HS clock information is included in the new report when a card capable of supporting **HS** links is provisioned (regardless of link provisioning).

Hardware Requirements

No new hardware is needed to support this feature.

5.33 REPT-STAT-TRBL Enhancement (Release 29.0)

This feature is intended to allow users to display only the non-inhibited troubles for captures. This facility allows customers to quickly identify new alarms, versus the old ones they no longer wish to see.

Hardware Requirements

No new hardware is needed to support this feature.

5.34 Response to Commands Issued Prior to Login (Release 21.0)

Currently, if a command is entered prior to logging in to the **EAGLE** that contains a syntax error, the **EAGLE** responds with a syntax error message. When the user corrects the command and re-enters it, the **EAGLE** then responds with an authority violation error message. This is annoying to the user. The command would not have been accepted prior to being logged into the **EAGLE**, regardless of whether its syntax was correct.

If a command is entered before the user is logged in to the **EAGLE**, the **EAGLE** responds with the

```
Command Rejected : Authority violation
```

message regardless of whether the command's syntax is correct.

5.35 Revoking a User ID (Release 21.0)

In Release 21.0, the system administrator can prevent the use of a user **ID** without having to remove it from the database. When a user **ID** is revoked, any future login attempts with the suspended user **ID** is rejected with the following message:

```
E2751 Cmd Rej: UserID has been revoked
```

The check for user **ID** revocation is made during the login process after the user has entered a valid user **ID** and password combination, and before any checks are made to see if the user's password must be changed.

A user **ID** is revoked by using the `revoke=yes` parameter of the `chg-user` command. The `rtrv-user` command output report shows which user **IDs** are revoked.

Revoking a user **ID** while the user is currently logged on to the system is allowed. In this case, the login session for the user immediately ends and the user is not allowed to enter any other commands.

The **EAGLE** does not allow user **IDs** assigned to the security administration command class to be revoked. If this is attempted, the `chg-user` command is rejected with the following error message:

```
E2759 Cmd Rej: Revocation of security admin userID not allowed
```

This prevents the system from becoming un-administrable because all user **IDs** have been revoked.

A revoked user **ID** can be put back into service using the `revoke=no` parameter with the `chg-user` command.

5.36 Route SRI_SM for non-local or ported out subscribers using GTT (Release 42.0)

The Route SRI_SM for non-local or ported-out subscribers using GTT functionality allows SRI_SM messages to be modified so that the message can be routed to an alternate network using Global Title Translation (GTT). This functionality allows processing to occur when the DN in the database is associated with both the Service Point (SP) and Generic Routing Number (GRN) network elements and the GRN is not present in the EAGLE 5 ISS HomeRN table, or when the subscriber is ported out and associated with the RN.

The message is altered by changing the SCCP Called Party Address to the country code (CC) + GRN + Directory Number (DN) or to CC + RN + DN. This alteration allows GTT to redirect the query to an alternate network. If a CC is not located in the DN, then the SCCP CdPA is converted to a GRN + DN or RN + DN format.

This conversion is performed only on ITU TCAP Begin SRI_SM MSUs.

If the MT-Based GSM SMS NP or the IS41 GSM Migration feature generates a response for the SRI_SM message then this functionality is not applicable.

5.36.1 Feature Control Requirements

The G-Port (Part Number 893-0172-01) or IS41 GSM Migration (Part Number 893-0173-01) feature must be enabled before the SRI_SM message routing functionality can be provisioned. One of the features must be turned on before processing can occur.

5.37 Routing Key Enhancements (IP⁷ Release 3.0)

The **Routing Key** Enhancements feature provides routing to **IP** devices with an **ITU** National or International Point code. In addition, routing for **TUP** messages is also provided.

Routing Key Enhancements, including the following features:

- Multiple **Routing Key** Registration allows for the registration of up to three routing keys in a single **TALI** message.
- **Q.BICC** Routing provides routing to **TCP/IP** sockets for **BICC** messages. **BICC** messages are very similar to **ISUP** messages, except the **CIC** has been expanded to 32 bits. Routing for **ANSI** or **ITU BICC** messages is based on **SI=13**, **OPC**, **DPC**, and **CIC**. The point codes within the routing key must be **ANSI**, **ITU National** or **ITU International**.
- **ITU Routing Key** Enhancements provide the following additional routing capabilities for international users:
 - **ITU ISUP CIC** Routing provides **OPC/DPC/CIC** routing to **IP** devices for **ITU ISUP** messages. Routing for **ITU ISUP** messages to an **IP** device is based on **SI=5**, **OPC**, **DPC**, and **CIC**. The point codes within the **ITU ISUP** routing key must be either **ITU National** or **ITU International**.
 - **ITU DPC-SSN** Routing provides **DPC/SSN** routing to **IP** devices for **ITU SCCP** messages. Routing for **SCCP** messages to an **IP** device is based on **SI=3**, **DPC**, and Subsystem. The point codes within the **ITU SCCP** routing key must be either **ITU National** or **ITU International**.
 - **ITU DPC-SI** Routing provides **DPC/SI** routing to **IP** devices for non-**ISUP** and non-**SCCP** **ITU** messages. Routing to **ITU** point codes on the **IP** network for non-**ISUP** and non-**SCCP** messages is based on the **Destination Point Code** and **SI** indicator, where **SI** is not 3, 4 (**ITU**), 5, or 13. A message with **SI=4** bound for an **ITU National** or **International** point code is assumed to be a **TUP** message, and is routed as such. The point codes with the **ITU DPC-SI** routing key must be either **ITU National** or **ITU International**.
 - Telephone User Part (**TUP**) Routing provides **OPC/DPC/CIC** routing to **IP** devices for **TUP** messages. Routing **TUP** messages to an **IP** device with an **ITU** point code is based on **SI=4**, **OPC**, **DPC**, and **CIC**. The point codes within the routing key must be **ITU National**. An **MSU** with **SI=4** bound for an **ANSI** point code will continue to be routed on **DPC-SI**.

5.38 RTDB Download Enhancement (Release 46.0)

With EAGLE 46.0 and EPAP 16.0, the RTDB download time from EPAP to EAGLE is improved, which results in a reduced delay for the EAGLE Service Module cards to achieve In-Service status.

5.39 RTDB Reload from Remote Time Interval (EPAP 16.0)

Reloading the Real-Time Database (RTDB) from the remote EPAP server and reloading the Service Module cards completes within one hour.

5.40 RTDB Retrieve (EPAP 9.0)

Description

The RTDB Retrieve feature allows the user to query (from the web GUI) data that resides in the RTDB (Real-Time Database). This feature enables the user to compare data in the PDB (Provisioning Database) with data in the RTDB to verify that they are consistent.

In previous releases of EPAP, queries on EPAP have been supported only by the PDB. The ability to retrieve RTDB data assists in troubleshooting cases where data is absent on EAGLE 5 ISS, but present in the PDB.

Data returned from RTDB is presented on the EPAP GUI in a format that is similar to data from the PDB. This similarity makes it easier to compare data between the two databases when a discrepancy is suspected.

New menu items been added to the EPAP menu:

- Single DNs
- DN Blocks
- Network Entities
- Single IMSIs
- IMEIs
- IMEI Blocks

RTDB retrieval screens are selectively revocable to users and groups by User Interface administrators.

Data can be retrieved while application software is running. Input screens look like the PDBA (Provisioning Database Application) input screen sections for single retrieval of the same data type. Output screens look like the PDBA output screen for the same data type.

A failure message will identify an item as not found if this is the cause of lookup failure.

Hardware Requirements

None.

Limitations

None.

5.41 RTRV-RTE/RTRV-DSTN: Support of PC Wildcards (Release 35.0)

Description

The RTRV-RTE/RTRV-DSTN Support of PC Wildcards feature enhances the `rtrv-rte` command to retrieve destinations by specifying the `**` (double asterisk) or `***` (triple asterisk) value for the `nc` and `ncm` subfields of the ANSI point code as follows:

- `rtrv-rte:dpc=ni-nc-**`
- `rtrv-rte:dpc=ni-nc-***`
- `rtrv-rte:dpc=ni-**-ni`
- `rtrv-rte:dpc=ni-***-***`
- `rtrv-rte:dpcn=-aa`
- `rtrv-rte:dpcn=nnnnn-*`
- `rtrv-rte:dpcn=m1-m2-m3-m4-*`

 **Note:**

If *, **, or *** is used for the nc subfield, then *, **, or *** must be also be used for the ncm field.

A double asterisk in the nc subfield of a network routing point code produces a summary report that shows all point code destinations that are members of the given network (21-**-*). This does not include the specified network routing point code. The following example shows a report generated using two asterisks in the This is the same function that currently exists for the rtrv-dstn command.

Hardware Requirements

The RTRV-RTE/RTRV-DSTN Support of PC Wildcards feature has no hardware requirements.

Limitations

The RTRV-RTE/RTRV-DSTN Support of PC Wildcards feature has no limitations.

5.42 RTRV-STP Command (Release 35.0)

Description

The RTRV-STP Command feature provides the new `rtrv-stp` command, which provides the functionality of the `rtrv-bip`, `rtrv-gpl`, `rtrv-card`, and `rept-stat-card` commands in a single command. The `rtrv-stp` command displays the current power consumption and power thresholds for all frames or for a specified frame, allowing users to retrieve the card location, board part number, revision, assembly serial number, DB Size, card type, GPL type, and GPL version for all card locations.

Hardware Requirements

The RTRV-RTE/RTRV-DSTN Support of PC Wildcards feature has no hardware requirements.

Limitations

The RTRV-STP Command feature has the following limitations:

- Since the Frame Power Consumption value is updated periodically at SCM from the FPBA task, the power consumption value displayed by `rtrv-stp` may not be the latest value but the last updated value.
- The `rtrv-stp` command may produce 850 Board Part Numbers instead of 870 Board Part Numbers.

5.43 RTRV-STP on FTRA

Description

The **RTRV-STP on FTRA** feature allows a user to retrieve **rtrv-stp** command information in a **CSVGEN** comma-delimited format, using **FTRA** Release 4.0. Refer to

the **FTP-Based Table Retrieve Application (FTRA) User Guide** in your Release 35.1 Customer Documentation for more information on **FTRA**.

Hardware Requirements

The **RTRV-STP** on **FTRA** feature has no hardware requirements.

Limitations

The **RTRV-STP** on **FTRA** feature has no limitations.

5.44 RTRV-TBL-CAPACITY Enhancement (Release 29.0)

This enhancement introduces the new command `rtrv-tbl-capacity`, which retrieves table use summary information.

Hardware Requirements

No new hardware is needed to support this feature.

5.45 EAGLE 5 SCCP Capacity Increase (Release 41.1)

The E5-SM4G Throughput Capacity feature is enhanced to support a 6800 TPS transaction rate per E5-SM4G card.

As part of this enhancement, the E5-SM4G Throughput Capacity feature is now a quantity feature. Part Number 893-0191-01 continues to support a maximum capacity of 5000 TPS per E5-SM4G card. Part Number 893-0191-02 supports 6800 TPS per E5-SM4G card.

[Table 5-10](#) shows the TPS capacities that are supported.

Table 5-10 TPS Capacities

Part Number	Maximum TPS Capacity per E5-SM4G Card	Maximum System Capacity
893-0191-01	3125	75,000 TPS with one or more EPAP-related features enabled and 24+1 cards
	5000	150,000 TPS with no EPAP-related or ELAP-related feature traffic and 31+1 cards
		120,000 TPS with G-Flex and the ANSIGFLEX STP option enabled and 24+1 cards
		40,000 TPS with ELAP and 8+1 cards
893-0191-02	6800	210,800 TPS with no EPAP-related or ELAP-related feature traffic and 31+1 cards
		163,200 TPS with one or more EPAP-related features enabled and 24+1 cards
		54,400 TPS with ELAP and 8+1 cards

5.45.1 Feature Control Requirements

The E5-SM4G Throughput Capacity feature requires a FAK for the desired quantity Part Number:

- 893-0191-01—5000 TPS Capacity
- 893-0191-02—6800 TPS Capacity

If the 6800 TPS Capacity quantity is enabled, then the 5000 TPS Capacity quantity cannot be enabled.

5.45.2 Hardware Requirements

E5-SM4G cards must be installed in the system before either E5-SM4G Throughput Capacity quantity can be used.

5.46 SCCP Loop Detection (Releases 35.6, 37.5)

The SCCP Loop Detection feature allows the EAGLE 5 ISS to detect SCCP looping of UDT/XUDT and UDTS/XUDTS messages for all concerned signaling transfer points (STPs).

An STP sends GTT messages to the capability point codes (CPCs) of mated nodes for load sharing; however, SCCP looping can result if the destination point code (DPC) is the same as either the originating point code (OPC) or the point code of any intermediate in the network. The CPC cannot be omitted because it is used in other functionality.

The SCCP Loop Detection feature allows a correlation to be made between true/secondary point codes and CPCs for all concerned STPs. This correlation allows the EAGLE 5 ISS to compare the OPC of an incoming MSU to the post-GTT DPC to determine the possibility of looping.

A Loopset table is provisioned to define the correlation between the true/secondary point codes and the CPCs.

The SCCP Loop Detection feature operates in the Notify and Discard modes. In the Notify (default) mode, the SCCP Loop Detection feature generates a UIM when it detects SCCP looping and does not discard the MSU. This UIM allows the user to capture and verify MSUs throughout the system for SCCP looping. In the Discard mode, the SCCP Loop Detection feature generates the same UIM when it detects SCCP looping and discards the MSU.

5.46.1 Feature Control Requirements

The SCCP Loop Detection feature has the following feature control requirements:

- A FAK for part number 893-0165-01
- The feature cannot be turned off after it has been turned on.
- A temporary FAK cannot be used to enable the feature.

5.46.2 Hardware Requirements

The SCCP Loop Detection feature requires DSM (4 GB) or higher cards. TSM cards are not supported.

5.46.3 Limitations

When this feature is implemented, the capacity limits for combinations of DN/IMSI will be less than what is supported today.

- Existing limit: {DN, IMSI} = {36M, 60M}, {12M, 82M} and {6M, 90M}
- New limit for EPAP 10.0: {DN, IMSI} = {36M, 52M}, {12M, 75M} and {6M, 82M}

This decrease in capacity is based on high-level engineering design for the feature. Since these combinations are not used in the field, this limitation does not affect any customers.

5.47 SCCP Message Type Screening (Release 22.0)

The allowed calling party address (**CGPA**) screen can screen messages for these **SCCP** message types: **UDT**, **UDTS**, **XUDT**, and **XUDTS**. A new parameter, `sccpmt`, has been added to the `ent-scr-cgpa`, `dlt-scr-cgpa`, and `chg-scr-cgpa` commands to configure the allowed **CGPA** screen to screen for these messages. A new field, **SCCPMT**, has been added to the output of the `rtrv-scr-cgpa` command to show the **SCCP** message type in the allowed **CGPA** screen.

5.48 SCCP on SLIC TPS Increase [13.6k] (Release 46.6)

With this feature, the max SCCP throughput supported on a SLIC card is increased to 13.6K TPS under certain conditions, and the nodal max SCCP throughput increases to 544K TPS.

An SCCP64 card will support 13,600 TPS if all of the following conditions are true:

- The card is a SLIC card
- If the card is provisioned as `data=EPAP`, the EPAP240MB option in STPOPTS must be OFF
- GSM Map Screening is not enabled for any linkset in the EAGLE

5.48.1 Hardware

The new 13,600 TPS rate is applicable only to cards running the SCCP64 application on SLIC cards.

5.49 SCCP Service Re-Route Capability (Release 34.3)

Description

The **SCCP** Service Re-Route Capability feature is designed to re-route **G-Flex** and **G-Port** traffic from a node that is unable to process traffic to alternate nodes within an operator network. This feature allows the user to mark the **G-Flex** or **G-Port** services **OFFLINE**, which causes messages to be re-routed to provisioned destinations, either alternate point codes

(PCs) or a **GTT** option. When the user returns either or both services to **ONLINE**, the services resume processing traffic. The **SCCP Service Re-Route** Capability feature is optional and doesn't affect normal **G-Flex** or **G-Port** functionality.

The **G-Flex** and **G-Port** services normally run in tandem with the **SCCP** service, with no way to halt **G-Flex** or **G-Port** without bringing down the entire **SCCP** service. The **SCCP Service Re-Route** Capability feature allows the user to mark the **G-Flex** and/or **G-Port** services **OFFLINE**, which re-routes traffic for those services to alternate nodes. The user can mark either or both services **ONLINE** to cause the service to resume processing traffic.

For example, in [Figure 6](#), **G-Flex** and **G-Port** traffic originating from **SSP_A**, **SSP_B**, and **SSP_C** is distributed between **STP_1** and **STP_2**. **G-Flex** and **G-Port** traffic is addressed to the relevant service **Capability Point Code (CPC)** of **STP_S1** and **STP_S2**. **GTT** traffic is addressed to **STP_1** and **STP_2**.

When the **G-Flex/G-Port** service is unavailable on **STP_1**, **STP_1** sends a response method **TFP** message regarding **STP_S1**. This causes **SSP_A** to stop using **Link_A1** for **G-Flex/G-Port** traffic. **STP_1** can re-route all in-transit **G-Flex/G-Port** traffic to **STPs** **STP_S2**, **STP_S3**, and **STP_S4** if provisioned. **SSP_A** now sends all of its **G-Flex/G-Port** traffic on link_A2. **GTT** traffic and **MTP** routed traffic is not impacted. Other **SSPs** perform similar rerouting.

When **G-Flex/G-Port** service is available on **STP_1**, **STP_1** responds with a **TFA** message (when route-set-test message is received) regarding **STP_S1**. This causes **SSP_A** to start sending the **G-Flex/G-Port** traffic through link_A1. Other **SSPs** perform similar rerouting.

Figure 5-14 G-Flex and G-Port Network Diagram

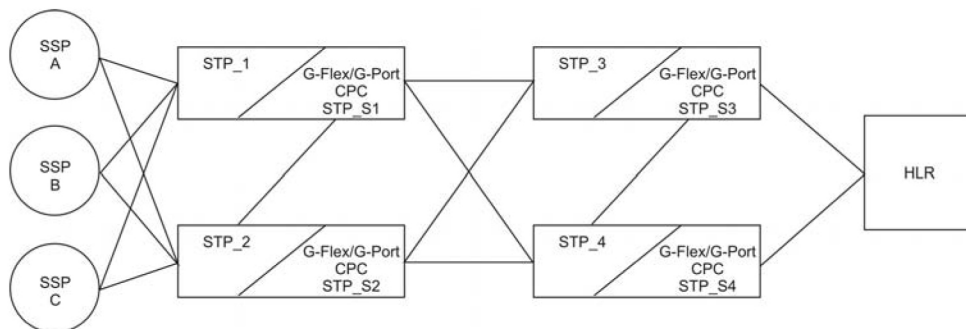

New Concepts

The **SCCP Service Re-Route** Capability feature introduces the following new concepts:

- “Service State”
- “Service Re-routing”
- “Service **Capability Point Code**”

Service State

Service State is an administered state of a **RTDB**-based service and indicates whether a service is **ONLINE** or **OFFLINE**. The **SCCP Service Re-Route** Capability feature supports Service State for the **G-Flex** and **G-Port** services only.

Service State allows a user to mark the **G-Flex** and **G-Port** services **OFFLINE** or **ONLINE**. If a user identifies a problem with **G-Flex** or **G-Port**, they can mark the service **OFFLINE** to initiate re-routing.

Once the service is returned to **ONLINE**, the **G-Flex** or **G-Port** service starts processing messages if at least one **SCCP** card is **IS-NR**.

 **Note:**

When the **SCCP Service Re-Route** Capability feature is first turned **ON**, the **G-Flex** and **G-Port** Service States are automatically set to **OFFLINE**. The user must change the relevant state to **ONLINE** before any traffic is processed by **G-Flex** or **G-Port**.

Service Re-routing

Service Re-routing is an optional function that allows a user to determine the destination of a re-routed message by use of a list of up to seven alternate **PCs** per domain or the **GTT** option. The **SCCP Service Re-Route** Capability feature supports Service Re-routing for the **G-Flex** and **G-Port** services only.

Re-routing is activated by marking a service **OFFLINE**. When a service is **OFFLINE**, any messages destined to that service are re-routed to available alternate **PCs** that have been defined for that service. If alternate **PCs** are not defined, or if none of the **PCs** are available, then the **GTT** option is invoked. If the **GTT** option is **YES**, then messages destined to that service go to **GTT**.

Service Capability Point Code

The **SCCP Service Re-Route** Capability feature provides **CPC** support for **G-Flex** and **G-Port** services. For messages destined to a service, the use of **CPCs** aids the adjacent nodes in knowing about service outage. When a service is brought down through administrative commands, all traffic destined to this service node performs the following actions:

- Generate response method **TFP** message to the adjacent node about service **CPC**. The **TFP** response to the adjacent node causes the traffic originating nodes to stop sending service traffic to this node. All service traffic coming into this node is sent to the alternate service nodes. Adjacent nodes initiate route-set-test procedures after receipt of the **TFP**.
- If the messages are destined to **EAGLE 5 SAS TPC**, then **TFP** messages are not generated when a service is **OFFLINE**. Therefore, the originator is not aware of the outage.
- Once the service is back in service on the **EAGLE 5 SAS**, a **TFA** is sent to the traffic adjacent nodes in response to route-set-test message. The traffic originating nodes then start sending service traffic to this node.

Hardware Requirements

The **SCCP Service Re-Route** Capability feature runs on **DSM** cards.

5.50 SCCP/TCAP Over IP Gateway for Point-to-Multipoint Connectivity (IP⁷ Release 1.0)

The **SCCP/TCAP-over-IP** feature allows **SS7** nodes to exchange **SCCP/TCAP** Query/Responses with an **IP-SCP**. The **IP⁷** Secure Gateway manages the point codes and subsystem numbers for the **IP-SCP**. From the **SS7** network perspective, the **TCAP** queries are routed using these **Point Code/SSNs**. The signaling gateway maps the **Point Code/SSN** to one or more **TCP** sessions, converts the **SS7 MSUs** to **TCP/IP** packets by embedding the **SCCP/TCAP** data inside a **TCP/IP** packet, and routes it over an **IP** network. The gateway also manages the application subsystem status from the **IP** network's perspective and the **SS7** network's perspective.

Figure 5-15 SCP Connectivity via TCAP over IP

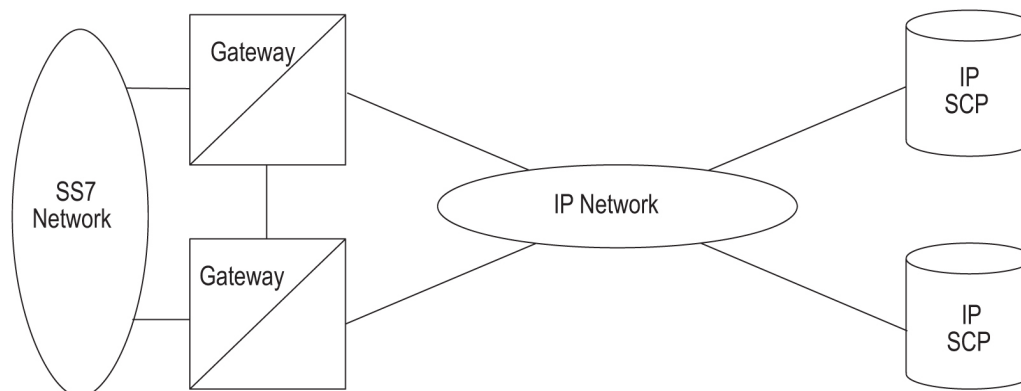

This feature provides **TCP/IP** point-to-multipoint connectivity by way of a new **GPL**, **SS7IPGW**, running on the **DCM** which, together with the hardware, provides connectivity to databases (or other switching equipment) for **SS7** devices that reside on ethernet **TCP/IP** networks.

A single **DCM** card running the **SS7IPGW application** provides connections to multiple **IP** devices (**IP-SCPs**, class 4 switches, class 5 switches, VoIP gateways, media gateway controllers, or remote access servers.) Multiple **DCM** cards running the **SS7IPGW** application are required, with similar configuration, to provide redundancy. The following is a common sequence of events that illustrates the use of point-to-multipoint connectivity:

1. Traditional **SS7** devices route **MSUs** (such as **TCAP** Queries) to the **STP**.
2. The gateway performs a global title translation and forwards the translated **MSU** to the correct **TCP/IP** device based on point code and **SCCP** subsystem information in the **MSU**.
3. The **TCAP** query is processed at the **IP-SCP**, and the **IP-SCP** sends a **TCAP** reply back to the **STP**.
4. The **STP** forwards the **TCAP** reply back to the sender of the original query.

To provide point-to-multipoint connections, a number of administration steps must first be performed, as follows:

- Links, link sets, destinations and routes to the destinations must be configured.
- The socket connections at each **DCM** card running the `SS7IPGW` application must be configured.
- The **SS7** routing keys that are transported over each defined socket at each card must be configured. **SS7** routing keys are filters consisting of values representing the **DPC**, **SI** and **SSN** fields from an incoming **MSU** message. All **MSUs** that match the filter are sent to the corresponding socket. The sockets represent **TCP** sessions. These keys allow for distribution of **MSUs** on the **IP** network.

5.51 SCCS Interface Support (Release 21.0)

This feature allows the **EAGLE** to interface to the **SCCS** terminals using existing **EAGLE** message input and output formats. The **SCCS** type is used for some network monitoring and surveillance applications. The **SCCS** terminals are the same as **KSR** terminals, except that a predefined “start-of-message” character is added to indicate the beginning of a new command response or unsolicited message.

Use the Change Terminal (`chg-trm`) command to configure the operational characteristics of the **SCCS** terminal. Refer to the Commands Manual of your current Documentation Suite.

The following error message is new to this feature:

```
E2149 Cmd Rej: TYPE = SCCS and PRTY=NONE combination is not allowed
```

Refer to the Commands Error Recovery Manual of your current Documentation Suite.

5.52 SCTP Checksum for Support for ADLER-32 and CRC-32 on per-card basis (Release 37.11)

The SCTP Checksum for Support for ADLER-32 and CRC-32 on per-card basis enhancement allows an SCTP checksum algorithm to be selected per IPLIMx or IPGWx card. Both the Adler-32 and CRC-32c checksum algorithms are supported for the specified card.

The selected SCTP checksum type is used by all the SCTP associations on the card, after all the SCTP associations for a specific IPLIMx/IPGWx card are closed and re-opened, or after the IPLIMx or IPGWx card is reloaded.

Note:

The system-wide SCTP checksum algorithm has precedence over the per card SCTP checksum algorithm setting.

5.52.1 Feature Control Requirements

There are no feature control requirements identified for this feature.

5.53 SCTP Checksum Update (EAGLE Release 30.0/IP7 Secure Gateway Release 8.0)

Description

Shortly after the introduction of the **Stream Control Transmission Protocol (IETF RFC 2960)**, a fundamental weakness was detected in the Adler-32 checksum algorithm currently used in the **RFC**. One requirement of an effective checksum is that it evenly and smoothly spreads its input packets over the available check bits. For small packets, Adler-32 provides weak detection of errors.

After much debate and research, the **IETF** has produced an improved checksum algorithm, **CRC-32c**, to be used with **RFC 2960**. The **SCTPChecksum Update** feature implements this improved algorithm. The **SCTPChecksum Update** feature provides a choice of **SCTP** checksum algorithms, and a user interface to both change and display the type of algorithm used.



Note:

This feature is a **SSEDCM**-based feature only (P/N 870-2372-01).

The **IPGWx** and **IPLIMx** support both **SCTP** checksum algorithms; the current Adler 32 checksum algorithm and the new **CRC-32c** checksum algorithm. The **CRC-32c Checksum** algorithm is implemented on all **SCTP**-based cards in the **IP7** or **EAGLE** node.

Background

Checksums provide protection against data corruption in the network. The sender of an **SCTP** packet computes a checksum according to an algorithm. The checksum is placed in the **Checksum** field residing in the **SCTP** Common Header (see [Table 5-11](#)). The receiver then re-computes the checksum, using the same algorithm. The **SCTP** packet is accepted if the checksum is valid; otherwise, the packet is discarded.

Table 5-11 SCTP Common Header Format

0	1	2	3	4	5	6	7	8	9	0	1	2	3	4	5	6	7	8	9	0	1	2	3	4	5	6	7	8	9	0	1				
Source Port Number										Destination Port Number										Verification Tag								Checksum							

Adler-32

Adler-32 was the only **SCTP** checksum algorithm supported and used by the **SG** prior to this feature. The **IETF** has determined that the Adler-32 checksum does not provide strong protection against error detection when applied to small packets. Because

¹ Checksums validate the correctness of the received data—specifically in the **SCTP** protocol stack, this technique ensures the integrity of the transmitted data from the far-end host.

SCTP protocol signaling messages are typically less than 128 bytes, a better-suited checksum algorithm is needed. This algorithm continues to be supported by the **SG**.

CRC-32c

Now supported by the **SG**, the **CRC-32c SCTP** checksum algorithm solves the limitations of Adler-32. **CRC-32c** provides better error detection for small packets than does Adler-32.

Hardware Requirements

This feature requires the **SSEDCM** (P/N 870-2372-01).

5.54 SCTP Payload Protocol Identifier needs to handle Big Endian or Little Endian byte order (Release 42.0)

For M2PA associations, the `chg/rtrv-uaps` commands are updated to indicate the byte format for the SCTP Payload Protocol Indicator (PPI) value that is received and transmitted in MSUs. The `uaps` parameter 4, bit 0 indicates whether the SCTP PPI value is received and transmitted in Network Byte Order (Big Endian) or Host Byte Order (Little Endian).

```
rtrv-uaps:set=1
```

```
eagle10213 10-01-07 14:01:00 EST EAGLE 42.0.0
SET  TIMER      TVALUE  PARM      PVALUE
  1     1         0        1         3
  1     2        3000     2         0
  1     3       10000     3         0
  1     4         5000     4         0
  1     5          0        5         0
  1     6          0        6         0
  1     7          0        7         0
  1     8          0        8         0
  1     9          0        9         0
  1    10          0       10         0
```

TIMER 2: False IP Connection Congestion Timer, max time an association can be congested before failing due to false congestion. SS7IPGW and IPGWI applications enforce 0-30000(ms). Not supported on IPSP application.

TVALUE : Valid range = 32-bits

TIMER 3: UA HeartBeat Period Timer T(beat), time (ms) between sending of BEAT msgs by NE. IPSP, SS7IPGW and IPGWI applications enforce 100(ms)-60000(ms).

TVALUE : Valid range = 32-bits

TIMER 4: UA HeartBeat Received Timer T(beat ack), timeout period for response BEAT ACK msgs by NE. IPSP, SS7IPGW and IPGWI applications enforce 100(ms)-10000(ms).

TVALUE : Valid range = 32-bits

PARM 1: ASP SNM options. Each bit is used as an enabled/disabled flag for a particular ASP SNM option. Not supported on IPSP application.

```

PVALUE : Valid range = 32-bits
        BIT                               BIT VALUE
        0=Broadcast                       0=Disabled ,
1=Enabled
        1=Response Method                 0=Disabled ,
1=Enabled
        2-5=Reserved
        6=Broadcast Congestion Status Change 0=Disabled ,
1=Enabled
        7-31=Reserved

PARM 2: ASP/AS Notification options. Each bit is used as an
        enabled/disabled flag for a particular ASP/AS
        Notification option. Not supported on IPSP application.
PVALUE : Valid range = 32-bits
        BIT                               BIT VALUE
        0=ASP Active Notifications        0=Disabled ,
1=Enabled
        1=ASP Inactive Notifications     0=Disabled ,
1=Enabled
        2=ASP AS State Query             0=Disabled ,
1=Enabled
        3-31=Reserved

PARM 3: UA Serviceability Options. Each bit is used as an
        enabled/disabled flag for a particular UA Serviceability
        option. Supported on IPSP, SS7IPGW, and IPGWI
        applications.
        UA Graceful Shutdown supported on IPSP for M3UA only.
PVALUE : Valid range = 32-bits
        BIT                               BIT VALUE
        0=UA Heartbeats                   0=Disabled ,
1=Enabled
        1=UA Graceful Shutdown            0=Disabled ,
1=Enabled
        2-31=Reserved

PARM 4: SCTP Payload Protocol Indicator byte order option. Bit
        indicates
        PPI value is RCV/TX in Big Endian or Little Endian byte
        format.
        Supported on IPSP-M2PA associations only.
PVALUE : Valid range = 32-bits
        BIT                               BIT VALUE
        0=Payload Protocol Indicator      0=Big Endian , 1=Little
        Endian
        1-31=Reserved

```

The `chg-assoc` command is updated to support M2PA associations for the `uaps` parameter. The `rtrv-assoc` command is updated to display the **uaps** value for M2PA associations. The output is also updated to increase readability.

Example 1 retrieves all associations.

```
rtrv-assoc
```

ANAME	CARD LOC	IPLNK PORT	LINK	ADAPTER	LPORT	RPORT	OPEN	ALW
a23456789012345	1305	A	A	M3UA	20000	30000	YES	YES
b23456789012345	1305	B	A	M3UA	20001	30001	NO	NO
c23456789012345	1307	A	A	SUA	20002	30002	YES	YES
d23456789012345	1307	B	A	M3UA	20003	30003	NO	NO
e23456789012345	1315	A	A	SUA	20004	30004	YES	YES
f23456789012345	1315	A,B	A	M3UA	20005	30005	YES	YES
g23456789012345	1317	B,A	A	SUA	20006	30006	YES	YES
m2pa1105b3	1105	A	B3	M2PA	31105	31105	YES	YES
m2pa1107a0	1107	A	--	M2PA	1107	1107	NO	NO
m2pa1107a1	1107	A	--	M2PA	11107	11107	NO	NO
m3ua1211a0	1211	A	A	M3UA	1211	1213	YES	YES
m3ua1211a1	1211	A	**	M3UA	11211	11213	YES	YES
m3ua1211a2	1211	A	B1	M3UA	21211	21213	YES	YES
m3ua1211a3	1211	A	A3	M3UA	31211	31213	YES	YES
m3ua1213a0	1213	A	A	M3UA	1213	1211	YES	YES
m3ua1213a1	1213	A	A1	M3UA	11213	11211	YES	YES
m3ua1213a2	1213	A	A2	M3UA	21213	21211	YES	YES
m3ua1213a3	1213	A	A3	M3UA	31213	31211	YES	YES
ipg1215a01	1215	A	**	M3UA	11215	1111	YES	YES
ipg1215a02	1215	A	**	M3UA	11215	1112	YES	YES
ipg1215a03	1215	A	--	M3UA	11215	1113	NO	NO
ipg1215a04	1215	A	--	M3UA	11215	1114	NO	NO
ipg1215a05	1215	A	--	M3UA	11215	1115	NO	NO
ipg1215a06	1215	A	--	M3UA	11215	1116	NO	NO

IP Appl Sock/Assoc table is (24 of 4000) 1% full

```
;
```

Example 2 retrieves a specified M2PA association.

```
rtrv-assoc:aname=m2pa1
```

ANAME	m2pa1							
LOC	1305	IPLNK	PORT	A	LINK	B1		
ADAPTER	M2PA	VER	M2PA	RFC				
LHOST	e1011001.1305a							
ALHOST	---							
RHOST	e1011501.1305a							
ARHOST	---							
LPORT	2005	RPORT	2005					
ISTRMS	2	OSTRMS	2	BUFSIZE	200			
RMODE	LIN	RMIN	120	RMAX	800			
RTIMES	10	CWMIN	3000	UAPS	7			
OPEN	NO	ALW	YES	RTXTHR	0			
RHOSTVAL	RELAXED	M2PATSET	1					
LSN	lsm2pa05							

5.55 SCTP Retransmission Control (Release 28.1) (IP7 Release 6.0)

This feature offers users a choice of two retransmission policies and enhanced control over the behavior of data retransmissions of **SCTP** associations in the **IP7 SG**. This functionality allows users to tailor retransmissions to their networks, on an individual association basis, to address these time-critical protocol constraints.

Note:

This is a non-orderable feature required for the three **IETF** Connectivity features and the **IPLIM** Protocol Support Enhancement feature.

Hardware Requirements

This feature requires a **SSEDCM** (Single Slot Enhanced **DCM**).

5.56 SEAS Enhancements (Release 26.0)

These enhancements are part of Tekelec's ongoing effort to become **SEAS**-compliant.

- The **EAGLE** now supports High Speed Links (**ATM-1.536 Mbps**) through the **SEAS** Interface]. (**CHG-slk** is not required to be supported.)
- The **EAGLE** now supports provisioning of supplier-specific parameters for the following **SEAS** commands:
 - **ADD/CHG/VFY-LS** (**Linkset**)
 - **ASGN/CHG/VFY-SLK** (**Link**)
 - **add/chg/vfy-gtwyls** (**Gateway Linkset**)
 - **ADD/CHG/VFY-DSTN** for the **NCAI** parameter

Note:

There is no functionally equivalent **EAGLE** command for the **SEAS** commands **ADD/CHG/VFY-GTWYLS**. Parameters for the link and screen set on the **EAGLE** will be used to provide the supplier-specific parameter for the **ADD/CHG/VFY GTWYLS** commands. Supporting screen set names as a supplier-specific parameter is not required.

Affected Commands

add-ls (**Linkset**)

The parameters in [Table 5-12](#) are not currently supported by the **SEAS** definition of the **ADD-LS** command:

Table 5-12 Supplier-Specific Parameters

Supplier-Specific Parameters	Description	Allowed Values
BEI	Broadcast Exception Indicator	YES, NO
GWSA	Gateway Screening Allowed Mode	ON, OFF
GWSM	Gateway Screening Messaging Mode	ON, OFF
GWSD	Gateway Screening Discard Mode	ON, OFF
SCRN	GWSScreen Set Name	AYYY
SLSCI	SLS Conversion Indicator	ON, OFF
ASL8	Adjacent SLS	YES, NO
SLTSET	SLTM Set ID	1 –20
NIS	Network Indicator Spare	ON, OFF
MTPRSE	MTP Restart Equipped	YES, NO

In order to allow users of the **SEAS** interface the ability to set values for **EAGLE**- specific parameters, the **unshaded** parameters in [Table 5-12](#) are allowed to be specified using the **SEAS** supplier specific parameter block. The **GWS**- specific parameters are not allowed in the supplier-specific parameter block because they are implemented as part of the supplier-specific parameter block of the **GTWYLS** entity; see [add-gtwyls](#).

The syntax for supplier-specific parameter “Z” of the **SEASADD-LS** command is as follows:

Syntax

```
"[BEI],L3TSET,[SLSCI],[ASL8],[SLTSET],[NIS],[MTPRSE]"
```

The following example is provided to help customers understanding the new capability of specifying supplier-specific parameter blocks via **SEAS** commands on the **EAGLE**.

Suppose the user wants to add a linkset where all of the Supplier Specific parameters get set to the default value. This can be done in four different ways:

Input Example

1. ADD-
LS::LS1201:000003:50,RCH::LNSCLLI1201-012001001:A::,G63D45G25-001-07
2. ADD-
LS::LS1201:000003:50,RCH::LNSCLLI1201-012001001:A:",,,,,,",":,G63D45G25-001-07
3. ADD-
LS::LS1201:000003:50,RCH::LNSCLLI1201-012001001:A:"0,1,0,0,1,0,0":,G63D45G25-001-07
4. ADD-
LS::LS1201:000003:50,RCH::LNSCLLI1201-012001001:A:",,0,0,1,0,0":,G63D45G25-001-07

The first method simply leaves out parameter "Z" and the appropriate default values are assigned.

The second method specifies parameter "Z" enclosed in quotes. All the members of the supplier-specific parameter block are optional, and can be omitted (the colons must always be specified if parameter "Z" is specified).

The third method specifies the appropriate default values for each supplier-specific parameter within the block.

The fourth method specifies default values for **SLSCI**, **ASL8**, **SLTSET**, **NIS**, and **MTPRSE**. All four commands will result in the same entry created in the **EAGLE** database.

chg-ls

The following parameters are not currently supported by the **SEAS** definition of the **CHG-LS** command.

Table 5-13 Supplier-Specific Parameters for chg-ls

Supplier Specific Parameters	Description	Allowed Values
TFATCABMLQ	TFA/TCA Broadcast Min. Link Quantity	0 –16
BEI	Broadcast Exception Indicator	YES, NO
GWSA	Gateway Screening Allowed Mode	ON, OFF
GWSM	Gateway Screening Messaging Mode	ON, OFF
GWSD	Gateway Screening Discard Mode	ON, OFF
SCRN	GWSScreen Set Name	AYYY
SLSCI	SLS Conversion Indicator	ON, OFF
ASL8	Adjacent SLS	YES, NO
SLTSET	SLTM Set ID	1 –20
NIS	Network Indicator Spare	ON, OFF
MTPRSE	MTP Restart Equipped	YES, NO

In order to allow users of the **SEAS** interface the ability to set values for **EAGLE** specific parameters the highlighted parameters above are allowed to be specified using the **SEAS** supplier specific parameter block. The **GWS**-specific parameters are not allowed in the supplier specific parameter block because they are implemented as part of the supplier-specific parameter block of the **GTWYLS** entity; see [add-gtwyls](#).

The syntax for supplier-specific parameter "Z" of the **SEASADD-LS** command is as follows:

Syntax

```
" [TFATCABMLQ] : [BEI] : L3TSET : [SLSCI] : [ASL8] : [SLTSET] : [NIS] : [MTPRSE] "
```

dlt-ls

There are no supplier specific parameters available for the **SEASDLT-LS** command.

vfy-ls

There are no supplier-specific parameters available for the **SEAS**VFY-LS command on input. However, the output of the VFY-LS command includes the following output for the supplier specific parameter block:

Syntax

```
"TFATCABMLQ:BEI:L3TSET:SLSCI:ASL8:SLTSET:NIS:MTPRSE"
```

add-gtwyls (Gateway Linkset)

In order to allow users of the **SEAS** interface the ability to set values for **EAGLE**-specific parameters the **unshaded** parameters in Table 5-14 are allowed to be specified using the **SEAS** supplier-specific parameter block.

Only **GWS**-specific parameters are allowed in the supplier specific parameter block. The shaded parameters (with exception to the **SCRN** parameter) are supported in the Linkset supplier-specific parameter block.

Table 5-14 Supplier-Specific Parameters for add-gtwyls

Supplier Specific Parameters	Description	Allowed Values
BEI	Broadcast Exception Indicator	YES, NO
GWSA	Gateway Screening Allowed Mode	ON, OFF
GWSM	Gateway Screening Messaging Mode	ON, OFF
GWSD	Gateway Screening Discard Mode	ON, OFF
L3TSET	Level 3 Timer Set	1
SCRN	GWSScreen Set Name	AYYY
SLSCI	SLS Conversion Indicator	ON, OFF
ASL8	Adjacent SLS	YES, NO
SLTSET	SLTM Set ID	1 –20
NIS	Network Indicator Spare	ON, OFF
MTPRSE	MTP Restart Equipped	YES, NO
ACTNAME	Stop Action Set Name	Alphanumeric(6)
DESTFLD	Destfld Screening	YES, NO

dlt-gtwyls

There are no supplier-specific parameters associated with the DLT-GTWYLS command.

chg-gtwyls

The supplier-specific parameter block for the CHG-GTWYLS command is equivalent to the supplier-specific parameter block for the ADD-GTWYLS command (see [add-gtwyls](#)).

vfy-gtwyls

There are no supplier specific parameters available for the **SEAS**VFY-GTWYLS command on input. However the output of the VFY-GTWYLS command will include the following output for the supplier-specific parameter block:

Syntax

```
"[GWSA],[GWSM],[GWSM],[ACTNAME],[DESTFLD],[SCRN]"
```

asgn-slk (Signaling Link)

In order to allow users of the **SEAS** interface the ability to set values for **EAGLE** specific-parameters, the **EAGLE** supports a supplier-specific parameter block for the **SEAS** command **ASGN-SLK**. The supplier-specific parameter block consists of all the parameters from [Table 5-15](#).

Table 5-15 Supplier Specific Parameters of asgn-slk

Supplier Specific Parameters	Description	Allowed Values
L2TSET	Level 2 Timer Set	1-20
L1MODE	Mode of Operation Used to Select Link Clocking Source	DTE, DCE
TSET	Transmitter Signal Element Timing	ON, OFF
ECM	Error Correction Method	BASIC, PCR
PCRN1	Number of MSUs Available For Retransmission Threshold	1-127
PCRN2	Number of MSU Octets Available For Retransmission Threshold	300-35500
LPSET	Link Parameter Set Identifier	1-20
ATMTSEL	ATM Timing Selector	LINE, INTERNAL, EXTERNAL
VCI	Virtual Channel Identifier	0-65535
VPI	Virtual Path Identifier	0-4095
LL	ATM Line Length	0-7

The syntax for supplier-specific parameter "Z" , of the **SEASASGN-SLK** command, is as follows:

Syntax

```
"[L2TSET]:[L Adresse 1MODE]:[TSET]:[ECM]:[PCRN1]:[PCRN2]:[LPSET]:[ATMTSEL]:[VCI]:[VPI]:[LL]"
```

dlt-slk

No supplier-specific parameter support is required for the **SEASASGN-SLK** command.

chg-slk

No supplier-specific parameter support is required for the **SEASCHG-SLK** command.

vfy-slk

There are no supplier-specific parameters available for the **SEAS**`VFY-SLK` command on input. However, the output of the `VFY-SLK` command includes the following output for the supplier-specific parameter block:

Syntax

```
"[L2TSET] : [L1MODE] : [TSET] : [ECM] : [PCRN1] : [PCRN2] : [LPSET] : [ATMTSEL] : [VCI] :
[VPI] : [LL]"
```

5.57 SEAS Enhancements, Autonomous Messages (Release 22.0)

The **EAGLE** in release 22.0 supports these **SEAS** autonomous messages.

- **REPT-GTWYACT** - notification that the gateway threshold has been exceeded
- **REPT-SCRREJ** - notification that an **MSU** has been discarded because of gateway screening.
- **REPT-DBCOPY** - notification that the **EAGLE**'s database has been either backed up or restored.
- **REPT-NOTRNS** - notification that the **EAGLE** is unable to perform a global title translation because of problems with the **GTT** tables and the **MSU** has been discarded.
- **REPT-MTPERR** - notification that the **EAGLE** cannot perform **MTP** level routing for a received **MSU** and that **MSU** has been discarded.
- **REPT-LKSTO** - notification that all signaling links in a linkset are unavailable because of multiple signaling link failures or processor outages.
- **RCVRY-LKSTO** - notification that the **EAGLE** has recovered from a previously reported linkset outage condition.
- **REPT-LINK-CGST** - notification that the value *occupancy threshold reached/exceeded* field in the **MSU** is set to a fixed value regardless of the congestion level being reported.
- **RCVRY-LINK-CGST** - notification that the value *occupancy threshold reached* field in the **MSU** is set to a fixed value regardless of the congestion level being reported.

This feature prevents duplicate autonomous messages to be sent to the **SEAS** ports.

This feature also introduces these new **EAGLE** commands to configure the thresholds for the **REPT-GTWYACT** and the **REPT-SCRREJ** messages.

- `set-gtwy-acthresh` - configures the gateway threshold
- `rtrv-gtwy-acthresh` - displays the current values of the gateway threshold
- `set-scrrej-prmtrs` - configures the quantity of **REPT-SCRREJ** messages are sent to **SEAS**
- `rtrv-scrrej-prmtrs` - displays the quantity of **REPT-SCRREJ** messages are sent to **SEAS**

These actions can also be performed from the **SEAS** interface with these **SEAS** command functions, **SET-GTWY-ACTHRESH**, **RTRV-GTWY-ACTHRESH**, **SET-SCRREJ-PRMTRS** and **RTRV-SCRREJ-PRMTRS**.

5.58 SEAS Gateway Audit Command (CHK-UNREF-ENT) (Release 22.0)

Release 22.0 introduces the `chk-unref-ent` command on the **EAGLE** and supports the **CHK-UNREF-ENT** command function on the **SEAS** interface.

This feature gives users the ability to identify unreferenced entities in the **EAGLE**'s gateway screening entity sets. These unreferenced entities can be dealt with by the user as required.

Unreferenced gateway screening entity sets are those entity sets that are not referenced by another entity with the next screening function identifier (**NSFI**) and next screening reference (**NSR**) combination or with the link set screening reference (that is, a screen set used by a link set). Any unreferenced gateway screening entities are displayed by the entity set name (screen set name) and screening reference (**NSFI**).

The **EAGLE**'s `chk-unref-ent` command uses these parameters.

Parameters

- `:aftpc`= Is the Affected **PC/SSN** entity set to be checked?
- `:blkopc`= Is the Blocked **OPC** entity set to be checked?
- `:blkdpc`= Is the Blocked **DPC** entity set to be checked?
- `:cdpa`= Is the Allowed **CDPA** entity set to be checked?
- `:cgpa`= Is the Allowed **CGPA** entity set to be checked?
- `:destfld`= Is the Affected **DESTFLD** entity set to be checked?
- `:dpc`= Is the **Allowed DPC** entity set to be checked?
- `:opc`= Is the **Allowed OPC** entity set to be checked?
- `:sio`= Is the **Allowed SIO** entity set to be checked?
- `:tt`= Is the **Allowed TT** entity set to be checked?
- `:all`= Are all the gateway screening entity sets to be checked?

The values for these parameters are either `yes` or `no`, with the default value being `no`.

5.59 SEAS Interface Support (Release 21.0)

This feature allows the **EAGLE** to interface with the **Signaling Engineering and Administration System (SEAS)**. The **Signaling Engineering and Administration System (SEAS)** is an interface defined by Bellcore and used by the Regional Bell Operating Companies (**RBOCs**), as well as other Bellcore Client Companies (**BCCs**), to remotely administer and monitor the signaling points in their network from a central location. **SEAS** provides a single, reliable, machine-to-machine interface by which commands are entered from a Signaling Engineering and Administration Center (**SEAC**) or a Signaling Network Control Center (**SNCC**) to various signaling points, such as **STPs**. These signaling points then provide command responses back to the

SEAC. The signaling points also provide automatic alarm and measurement data to the **SEAC**. Specifically, **SEAS** is used for the following functions.

- Memory Administration (Recent Change and Verification)
- Network Maintenance
- Network Data Collection (Measurements)
- Network Traffic Management Surveillance
- **SEAS** Application Control
- Supplier Specific Functions

The **SEAS** interface has the following capabilities:

- Flow through messages - This allows any **EAGLE** command to be entered into the system from a **SEAS** console.
- Recent change and verify (immediate activation only) for following data entities:
 1. **MTP** (routes, route sets, signaling links, linksets, point codes, etc.)
 2. **GTT** (global title translations, subsystems, and mated applications)
 3. **GWS** (all gateway screening tables)
- Data collection (autonomous and on-demand) for existing measurement data
- On-occurrence output capability for existing reports
- Supports one active X.25 signaling link and one backup X.25 signaling link. Each X.25 signaling link supports a minimum of 10 **PVCs** on a **LIMV35** card at data rates of 64 kbps, 56 kbps, 19.2 kbps, 9.6 kbps, 4.8 kbps and 2.4 kbps on a per link basis.

The **SEAC** uses X.25 links to transmit data to and receive data from the signaling points it is monitoring. Terminal inputs to the **EAGLE** use asynchronous **RS-232** ports. An operations system support applications processor (**OAP**) is used to allow the **EAGLE** to communicate with the **SEAC**. The **OAP** is an adjunct processor that interfaces to a **BX.25** link and converts the data stream to an asynchronous serial format. All conversion from **SEAS** to **EAGLE** command sets takes place on the **EAGLE**. Two terminal disk module (**TDM**) ports (**RS-232**) running at 19,200 bps connect the **OAP** to the **EAGLE**. Two **BX.25** links connect the **OAP** to the **SEAC**. The **OAP** is mounted in a frame similar in design to the other frames used in the **EAGLE**, and is labeled as **OAPF**.

The **OAP** is a **TEXAS MICRO™** Intelligent Processor Unit Telecommunications Server, model 9605 (Sparc 05, 85 **MHz** processor) and contains:

- 32 megabytes of **RAM**
- a 1.02 gigabyte hard drive using a **SCSI** interface
- a 1.44 megabyte floppy disk drive, a high-speed serial interface (**HSI**) **SBUS** card (with 4 synchronous ports)
- **RS-232C**-extender **SBUS** communications board (with 4 asynchronous ports).

The **OAP** is powered from the **OAP** frame's fuse and alarm panel with -48 **VDC**.

The **OAP** uses the following software to allow the **EAGLE** to communicate with the **SEAC**:

- **SUN™** Solaris version 2.4 operating system
- SunLink Solaris version 9 for X.25
- The **SEAS** application software.

 **Note:**

Some of the names of the **EAGLE** measurement counters have been changed to match the names used by **SEAS**. [Table 5-16](#) shows the names of the measurement counters that have changed and the measurement reports and entity types that contain these counters.

Table 5-16 Changed EAGLE Measurement Names

Measurement Report	Measurement Entity Type	Current Measurement Name	New Measurement Name
ALL	STP	IMSINVDPC	MSINVDPC
ALL	STP	IMSINVSIO	MSINVSIO
COMP	LINK	DURLNKUNV	DRLKOTG
COMP	LINKSET	MSURGTT	MSUSRGTT
COMP	LINKSET	OCTRQGTT	OCTRCGTT
MTCB, MTCBTH	LINK	LNKAVALT	LNKAVAL
MTCB, MTCBTH	LINK	DRLNKINH	DRLKINHB
MTCB, MTCBTH	LINK	SURCVERR	MSURCERR
MTCB, MTCBTH	LINK	NEGACKRCV	NEGACKS
MTCB, MTCBTH	LINK	NEARMGINH	NEARMGIH
MTCB, MTCBTH	LINK	NDCLFABN	NDCFLABN
MTCB, MTCBTH	LINK	NDCLFXDA	NDCFLXDA
MTCB, MTCBTH	LINK	NDCLFXER	NDCFLXER
MTCB, MTCBTH	LINK	NDCLFXDC	NDCFLXDC

5.60 SEAS Over IP (Release 37.5)

The SEAS Over IP (SOIP) feature provides a TCP/IP-based interface for SEAS. The SEAS interface constitutes the path between the EAGLE 5 ISS and the Common Channel Signaling Message Router (CCS MR).

After the SEAS Over IP feature is enabled and turned on, the EAGLE 5 ISS acts as a client and connects to the CCS MR, which acts as the server. Data is passed between the EAGLE 5 ISS and the CCS MR using the SR-5129 protocol.

The SEAS Over IP feature can be used to replace the current EOAP in the EAGLE 5 ISS and will be used as the sole solution for future SEAS interface installations. However, the EOAP feature is still supported. If the EOAP is correctly provisioned, then EOAP functionality resumes automatically when the SEAS Over IP feature is turned off. The EOAP and SEAS Over IP features cannot operate at the same time.

The SEAS Over IP feature is integrated into the **ipshc** GPL on the E5-IPSM card. The E5-IPSM card allows one of eight IP terminals to be configured as the SEAS terminal to provide connectivity between the CCS MR and the EAGLE 5 ISS. The E5-IPSM card provides the EAGLE 5 ISS with generic IP-based services, such as Telnet and FTP, on the remaining 7 IP terminals.

The SEAS Over IP feature must be configured on both the EAGLE 5 ISS and the CCS MR. EAGLE 5 ISS commands are used to configure CCS MR information on the EAGLE 5 ISS. The CCS MR is configured directly. Refer to *Telcordia Configuration Specification "Telcordia Technologies System Documentation", BD-SNAM-ADMIN-4 Issue 14, November 2006* for information on configuring the CCS MR.

The SEAS Over IP feature supports the configurations shown in the following table:

Table 5-17 SEAS Over IP Configurations

SOIP Configuration	Description
Dual E5-IPSM with Single CCS MR	<p>Consists of two E5-IPSM cards with one SEAS terminal connection to a single CCS MR. Up to 3 E5-IPSM cards can be provisioned per system; however, the SEAS terminal is supported on only two out of the three E5-IPSM cards.</p> <p>The connection to the CCS MR is dedicated to SEAS; however the E5-IPSM card can be used for other IP-based operations.</p> <p>The E5-IPSM cards operate redundantly, allowing two active connections to the CCS MR. Different SEAS information can be transmitted and received separately over each connection to the CCS MR.</p>
Dual E5-IPSM with Dual CCS MR (loosely coupled)	<p>Consists of two E5-IPSM cards connected to a loosely coupled pair of CCS MRs. The CCS MRs operate in a round robin manner if they each have an active connection to an E5-IPSM card.</p>
Simplex E5-IPSM	<p>Consists of one SEAS terminal configured on one E5-IPSM card to create a connection to one CCS MR. This configuration does not provide redundant connections to the CCS MR and is intended to serve as a restricted mode until another E5-IPSM card can be returned to service.</p> <p>The connection to the CCS MR is dedicated to SEAS; however, the E5-IPSM card can be used for other IP-based operations. All SEAS information is transmitted over the single IP connection to the CCS MR. The SEAS system is in an IS-ANR/Restricted state if the system is in Simplex E5-IPSM SEAS operation, and a Major alarm is present on the SEAS system.</p> <div data-bbox="1122 1503 1458 1705" style="border: 1px solid #0070C0; background-color: #E6F2FF; padding: 10px; margin-top: 20px;"> <p> Note:</p> <p>Simplex SEAS operation is not recommended.</p> </div>

5.60.1 Feature Control Requirements

The SEAS Over IP feature has the following feature control requirements:

- A FAK for part number 893-0188-01

- The feature is an On/Off feature.
- A temporary FAK cannot be used to enable the feature.
- The IPUI feature must be enabled before the SEAS Over IP feature can be enabled. The IPUI feature must be turned on before the SEAS Over IP feature can be turned on.

5.60.2 Hardware Requirements

At least one E5-IPSM card must be provisioned in the EAGLE 5 ISS.



Note:

Two E5-IPSM cards are recommended for redundant connectivity to the CCS MR.

5.60.3 Limitations

The SEAS Over IP feature has the following limitations:

- MMI messages are not supported.
- The CCS MR node name is not configurable by the EAGLE 5 ISS. The CCS MR must be assigned a name by Telcordia.
- The only supported Authentication Mode in EAGLE 5 ISS for Client Authentication for communication with the CCS MR with the Security Feature ON is Password Authentication.

5.61 SEAS Verify Signaling Route-Set Status and SCCP Application Status Command (VFY-SRSAPST) (Release 22.0)

Release 22.0 supports the **VFY-SRSAPST** command function on the **SEAS** interface which is used to display the status of the current **MTP** signaling routesets, the status of individual routes, and the status of the **SCCP** application subsystem for specified destinations and applications that the **EAGLE** routes traffic to. This feature reduces the need to use non-**SEAS EAGLE** commands with the **SEAS** Flow-Through command to display this information.

5.62 Secure GUI Access (EPAP 16.0)

As an enhancement to system security, the default protocol for GUI access to the EPAP is changed from HTTP to HTTPS protocol. EPAP uses TCP port 443 for HTTPS and port 80 for HTTP. The customer must reconfigure the existing installation for HTTPS prior to upgrading the EPAP software to EPAP Release 16.0. During this reconfiguration, if the customer uses a firewall, the firewall must be configured to allow traffic on the HTTPS port 443.

5.63 Security Enhancements (EPAP 14.0)

Security features for EPAP 14.0:

Rebase to TPD 4.0 or higher

EPAP is rebased to TPD 4.0 to pick up security improvements and better password restrictions.

Change of kernel parameters to prevent network attacks

Kernel parameters are modified to reduce the possibility of network attacks and other security breaches.

Removal of .rhosts

The `/home/epapall/.rhosts` file is removed from EPAP to prevent unauthorized access to the servers.

Restrict root account access

A new `allowRoot` script is introduced to modify Access Restriction for root account.

usage:

```
* [ allowRoot OFF] -
Comment all the entries in /etc/securetty
- PermitRootLogin Yes|No in /etc/ssh/sshd_config
- Uncomment|Comment the line:
"#auth required /lib/security/$ISA/pam_wheel.so use_uid" in file
/etc/pam.d/su

* [ allowRoot ON] -
Uncomment all entries in /etc/securetty except ttyS0
- PermitRootLogin Yes|No in /etc/ssh/sshd_config
- Uncomment|Comment the line:
"#auth required /lib/security/$ISA/pam_wheel.so use_uid" in file
/etc/pam.d/su

* [ allowRoot tty ON|OFF] -
Uncomment|Comment all ttyN in /etc/securetty

* [ allowRoot ttyN ON|OFF]

- Uncomment|Comment only ttyN specified by user

* [ allowRoot ttyS0 ON|OFF]

- Uncomment|Comment only ttyS0

* [ allowRoot ssh ON|OFF] -

PermitRootLogin Yes|No in /etc/ssh/sshd_config
* [ allowRoot allowSU
ON|OFF] - Uncomment|Comment the line:
```



```
"#auth required /lib/security/$ISA/pam_wheel.so use_uid" in file  
/etc/pam.d/su
```

TCP Wrappers

A new script `manageEPAPAuthIp` is introduced. This script is used to list, add, or delete Authorized IPs. If the value of `Restrict` server access to authorized IPs is set to `no`, then the server can be accessed from any IP address. If the value is set to `yes`, then the server can be accessed only from the IP addresses that are added in file `/etc/hosts.allow`.

5.64 Security Log Increase (Release 26.05)

Security Logging is used to store the commands that are issued on **EAGLE**, either using the **EAGLE** terminal, or via **SEAS** Port. The Security Logging facility also stores additional information about the command, such as, date/time received, terminal on which received, UserID, and result of the command execution.

The **Security Log** Increase feature increases the Log size from 10K entries to 50K entries.

Increasing the FTA (File Transfer Area)

The **FTA** is used to store the security logs and the hourly and daily measurements (weeks worth of measurements data [5]). The **FTA** is designed to contain four security logs, each of size 2.5 **MB** (10K entries * 256 record size). Since the size of the security log has been increased from 10K to 50K, the **FTA** has been increased by at least 40MB. Hence the **FTA** has been increased to 100MB to accommodate this feature.

Upgrade Considerations

Before the upgrade, entire security log *must* be uploaded. The procedure to upload the security log follows:

1. Issue the `REPT-STAT-SECULOG` command to determine which security log should be uploaded. Under normal operating conditions, the standby **OAM**'s security log should always contain 0 in the **ENTRIES** column, and thus should never need uploading. However, if the standby **OAM**'s log contains one or more un-uploaded entries, it should be uploaded as well.
2. Issue the `COPY-SECULOG` command with appropriate parameters to cause the log to be copied to the **FTA** area. Note the name of the file that is created in the **FTA** area, and also the location 1114/1116 of the **FTA** area which received the copy. This information will be displayed in the scroll area at the successful conclusion of the `COPY-SECULOG` command.

If the security log has to be ported onto a **PC**, the following two steps need to be performed as well

3. On an **EAGLE** terminal that is being emulated on a suitably-equipped **PC** (e.g. a **PC** running ProComm), issue the `ACT-FILE-TRNS:LOC=xxxx` command, specifying `xxxx` as the location 1114 or 1116 of the **FTA** area containing the log to be uploaded.
4. Start a Kermit download session on the **PC**. If using ProComm, this is accomplished by selecting the "Online" menu item, then "Kermit command", then "Get file". At this point a dialog box will be presented asking for the name of the file

to be transferred. Enter the name of the file noted during the `COPY-SECULOG` command in step 3, and press the **OK** button to transfer the file from the **EAGLE** to the **PC**.

Limitations

Due to the circular nature of the security logs, if the security log is not uploaded when it is full, it will start to overwrite the contents. Hence the security log should be uploaded when "log full" alarm is raised. This feature does not affect any other **GPL**'s running on other cards.

5.65 Selective Alarm Inhibiting (Release 22.0)

This feature allows the user to turn off major and minor alarms for specific devices. Critical alarms cannot be turned off. The following are examples of situations where a user may want to turn off alarms.

- When repeated alarms from malfunctioning equipment could mask valid alarms, for example, a signaling link that is out of service because of a physical break that cannot be repaired for days, the alarm for that signaling link can be turned off.
- The **EAGLE** database is being configured. Alarms are generated immediately after entries are entered into the database. If these alarms are ignored and a problem develops that requires immediate attention, that problem may be ignored.

Alarms can only be turned off for these devices or entities.

- cards in the database
- signaling links in the database
- linksets in the database
- **EAGLE** terminals
- system clock
- **TCP/IP** data links in the database
- customer defined troubles
- **SEAS** X.25 links

When the system has alarms only for devices that have their alarms turned off, all the alarm indicators (visual and audible) are turned off. If alarms exist for devices that have not been turned off, or for entities whose alarms cannot be turned off, the alarm indicators remain on.

The alarm indicators are turned on only for devices or entities that do not have their alarms turned off, or that cannot be turned off.

When an alarm is turned off, no unsolicited alarm messages (**UAMs**) are generated for the device when an alarm condition for that device is detected.

When an alarm is turned off, **UIM 0004** is displayed to inform the user that the alarm for the specified device has been turned off. In this example, the alarms for card 1201 have been turned off.

UAM

```
RLGHNCXA03W 97-06-07 14:56:48 EST Rel 22.0.0  
5005.0004    CARD 1201 SS7ANSI    Device alarms inhibited
```

If an alarm is turned off, it remains off even if the **MASP** is reset.

A count of the alarms that are turned off is shown in the alarm status region of the **VT320** display terminal (Figure 5-15). The alarm status region (Figure 5-16) of the terminal display contains four boxes with numbers underneath. The boxes contains the labels for the alarm types and the numbers show the number of each type of alarm that has been detected on the **EAGLE**.

- **CRIT** - critical alarms - Indicates a severe, service-affecting condition has occurred and that immediate corrective action is needed, regardless of the time of day or the day of the week
- **MAJR** - major alarms - Indicates a serious disruption of service or the failure of important circuits is taking place. These troubles require attention and response to restore or maintain system capability
- **MINR** - minor alarms - Indicates a trouble, but does not have a serious effect on service.
- **INH** - inhibited alarms - alarms that have been turned off.

Figure 5-16 EAGLE Terminal Display

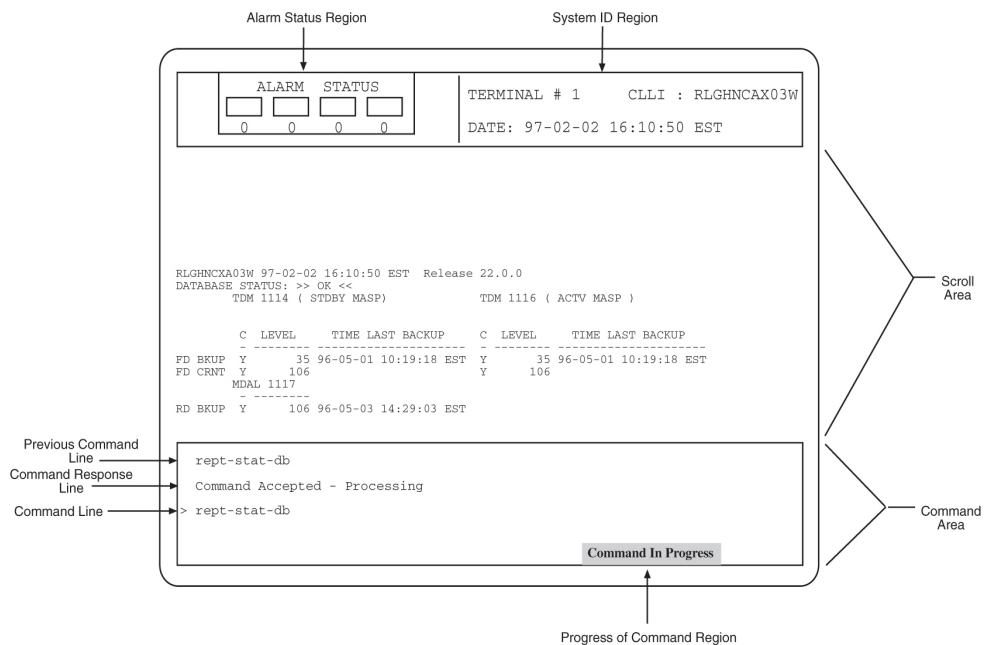

Figure 5-17 Alarm Status Region of the EAGLE Terminal Display



5.66 Self Healing DN Range in EPAP Database (EPAP 14.0)

The Self Healing DN Range in EPAP Database feature sports a single DN Block conflict in the EPAP database by allowing the EPAP database to *self heal* when a command is executed to create a new DN Block that conflicts with existing DN Blocks. This feature allows defragmentation of the DN Blocks, where a DN Block is split into child DN Blocks when conflicting DN Blocks are added and then returned to the parent DN Block upon deletion of particular child DN Blocks.

For typical provisioning configurations, the average provisioning rate is approximately 50 Commands per Second (CPS). With the Self Healing DN Range in EPAP Database feature turned on, the average provisioning rate may decrease below 50 CPS. In worst case conditions, the provisioning rate may decrease to 18 CPS.

By limiting the number of commands in an import file, the provisioning rate can be improved, depending on the provisioning configuration. For example, multiple import files limited to 200,000 commands are more efficient than a single import file of several million commands. Other performance factors related to the Self Healing DN Range in EPAP Database feature are associated with the internal data distribution, which cannot be directly influenced by the user. If provisioning performance falls below expected levels, contact [My Oracle Support \(MOS\)](#).

When a self healing EPAP database encounters a conflict:

1. Pre-existing/conflicting DN Blocks are automatically deleted from the EPAP database.
2. New DN Blocks are created successfully with new attributes.
3. Old DN Blocks are split to create more DN Blocks for the range not covered by the new DN block.

When a new DN Block is deleted, a range of numbers is returned to the original DN Block.

Rules for the Self Healing DN Range in EPAP Database feature

- If the new DN Block is a subset of an already existing DN Block with different properties, the old DN Block is split into either 2 or 3 new DN Blocks.
- The new DN Block cannot have the same **bdn** and **edn** as an existing DN Block.
- The new DN Block cannot have a single DN address.
- The resulting DN Block cannot have a single DN address.
- More than one conflicting DN Block cannot exist in the EPAP database.
- If the new DN Block is a subset of an existing block with same properties, then the DN Block cannot be created.
- If the new DN Block conflicts with an existing block and is not its subset, then the new DN Block cannot be created.
- A DN Block that conflicts with a DN Block and has a `split` option of `no` cannot be inserted.
- A DN that conflicts with a DN Block and has a `split` option of `no` cannot be inserted.
- If a DN Block that is created by splitting an existing DN Block is deleted, then the complete DN Block that existed before the split is returned to the EPAP database.

Error Codes

Error Codes Introduced by the Self Healing DN Range in EPAP Database feature:

- **PDBI_MULTI_DNB_CONFLICT**: More than one conflicting DN Block exists in the EPAP database.
- **PDBI_DNB_SAME_PROPERTIES**: A DN Block with the same properties exists in the EPAP database and is a superset of the requested DN Block. Splitting eligibility of a DN Block is not a property for this error.
- **PDBI_DNB_SPLIT_NOT_ALLOWED**: an existing DN Block that was specified at the time of its creation or update is ineligible for splitting.
- **PDBI_DNB_DLT_NOT_ALLOWED**: A fragment of a master range cannot be deleted while its subranges are present.
- **PDBI_DNB_PARENT_PROPERTY_MISMATCH**: A fragment of a master range with differing attributes cannot be deleted. Splitting eligibility of a DN Block is a property for this error.

5.67 Selective Homing of EPAP RTDBs (Release 29.0)

Currently, the **RTDBs** on an **EPAP** (A or B) will look for and receive updates from the local **PDBA** process on the local **EPAP A** (**PDBA** on the same **MPS** node as the **RTDB**), regardless of whether it is the active or standby **PDB**. An **RTDB** will only receive updates from the remote **PDBA** process on the mate **MPS** node if the local **PDBA** cannot be accessed.

Some customers would prefer to have all **RTDBs** within an "**MPS System**" (both nodes of a mated pair, or even multiple nodes within several mated pairs) always receiving updates from the active **PDBA** process, regardless of whether it is the local or remote **PDBA**.

The Selective Homing of **EPAP RTDBs** feature implements an **EPAP** configuration option that allows the customer to choose whether the **RTDBs** on a given **MPS** node will receive updates from a specific **PDBA** process (which may or may not be active), or from the active **PDBA** process (which may or may not be local). This option is selectable via the **EPAP UI**.

The terminology "specific **PDBA**" is used instead of "local **PDBA**," because architectures may result in an **MPS** without a **PDB** on **EPAP A**, in which case the **RTDBs** on that node would not have a "local **PDBA**." Specific homing would specify the **IP** addresses of the **MPSs** with the first and second choices of **PDBA**. In a two-node **MPS** system, this maps directly to "local" homing.

Hardware Requirements

No new hardware is required to support this feature.

Enhancements to the User Interface

A new section will be added to the **RTDB Status** screen of the **EPAP UI** to display the **RTDB Homing** policy for both **RTDBs** on the **MPS**.

The **PDBA Status** sections of both the **RTDB Status** and **PDBA status** screens will be enhanced to display the current **RTDB** clients.

Upgrade Considerations

This feature does not impact the **EPAP** 1.x/2.x to 3.0 upgrade. New **EAGLEs** may not be included for provisioning until all affected sites have been upgraded to **EPAP** 3.0. **RTDB** homing policy may not be changed until all affected sites have been upgraded to **EPAP** 3.0. Interaction with **EAGLE** is not affected by this feature.

5.68 SFAPP Use Case 3 — VLR Validation using IMEI (Release 46.7)

This use case is for Outbound roaming MAP messages: Time, Location Check messages, as defined by GSMA PRD FS.11, SS7 Interconnect Security Monitoring and Firewall Guidelines. This use case challenges the VLR after the Update Location procedure is complete by asking for the IMEI information in the Provide Subscriber Information message.

The four main Time, Location Check messages include:

- **Send Authentication Info** - VLR or the SGSN initiates the MAP Send authentication info procedure to retrieve authentication information from the HLR.
- **Provide Subscriber Info** - This message is sent by EAGLE to the VLR or SGSN to retrieve the subscriber state, location information, in this case IMEI.
- **Provide Subscriber Info ACK** - This message is sent as an acknowledgment to the PSI from EAGLE to the VLR or SGSN.
- **Purge MS** - If a roaming subscriber is suspected to be a malicious or fake user, EAGLE generates this message to HLR. On receiving this message, HLR marks the subscriber unreachable.

This use case challenges the visited VLR after the update location procedure has been completed by asking for the subscriber's IMEI information in a PSI message. One of these actions can then be taken:

1. The IMEI information can then be compared against an external database to validate the IMEI and consequently the VLR by either allowing the original procedure to complete or fail it by initiating in a Purge MS operation, or
2. The IMEI information can be added to/updated in the external database if the VLR is trusted and the IMEI is validated.

Figure 5-18 shows the call flow.

Figure 5-18 Graylisted VLR Challenge

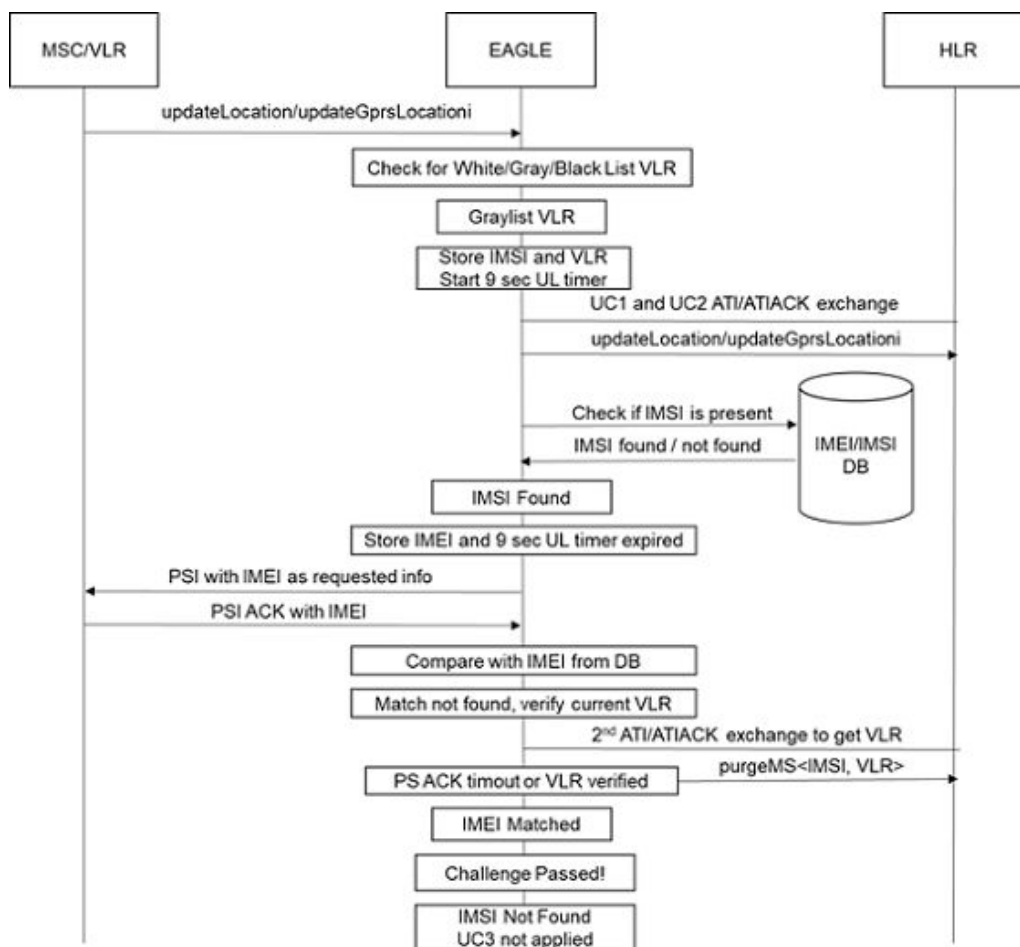

Limitations

The limitations include:

- This use case is only supported on SLIC cards.
- The stateful screening of messages may add up to 300 ms latency on average.
- The stateful security solution is only applied on Gateway STP nodes.
- SFAPP UC3 and SS7 firewall SFLOG features cannot coexist on same node.
- The following features are not compatible with SFAPP:
 - GSM MAP screening - SFAPP card does not support EGMS.
 - HLR Routing feature (GFLEX) on the same node. GFLEX interaction may be required for the ATI messages that need to be routed to the correct HLR for messages that do not have HLR address in the CdPA. This can be done by routing the message using the EAGLE mate using the C-Links.

For complete Use Case information, see the *Stateful Applications User's Guide*.

5.69 SFAPP Use Case 4 - Intelligent VLR Whitelist (Release 46.7)

This use case is for Outbound roaming MAP messages, as defined by GSMA PRD FS.11, SS7 Interconnect Security Monitoring and Firewall Guidelines. This use case uses a whitelist that is created as part of learning from the validation attempts defined in Use Cases 1 through 3.

To implement a whitelist 'learning' based validation for the VLR, where the VLR addresses are validated from tables configured/stored on a disk in the STP, the tables are differentiated into two classes: Static and Dynamic VLR tables. Both classes contain VLR Tables.

The two static VLR tables are:

- Static VLR profile table
- Static VLR roaming table

The two dynamic VLR tables are:

- Dynamic VLR profile table
- Dynamic VLR roaming table

Figure 5-19 shows the VLR challenge flow.

Figure 5-19 Dynamic VLR Learning (VLR Whitelisting)

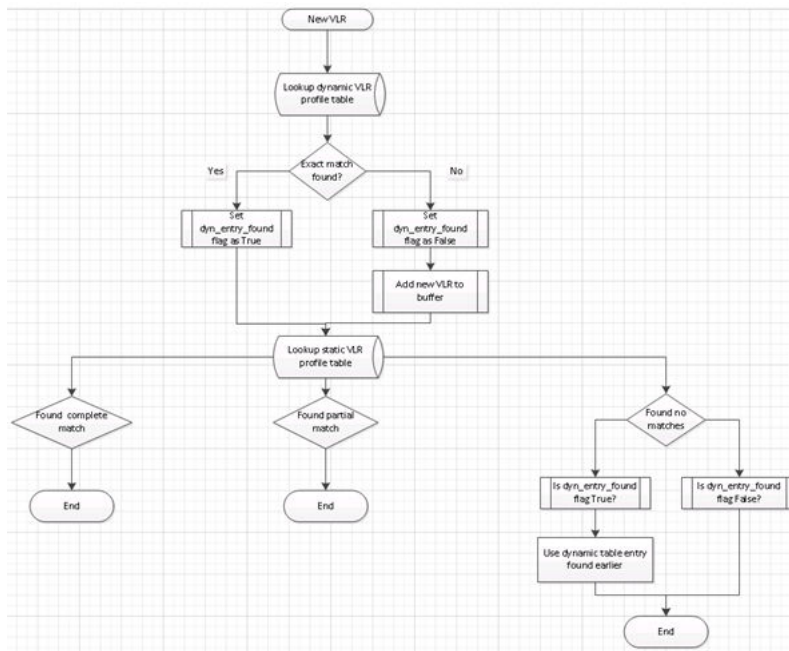

Limitations

The limitations include:

- This use case is only supported on SLIC cards.
- The stateful screening of messages may add up to 300 ms latency on average.
- The stateful security solution is only applied on Gateway STP nodes.
- SFAPP UC3 and SS7 firewall SFLOG features cannot coexist on same node.
- Exist on same node. The following features are not compatible with SFAPP:
 - GSM MAP screening - SFAPP card does not support EGMS.
 - HLR Routing feature (GFLEX) on the same node. GFLEX interaction may be required for the ATI messages that need to be routed to the correct HLR for messages that do not have HLR address in the CdPA. This can be done by routing the message using the EAGLE mate using the C-Links.

For complete Use Case information, see the *Stateful Applications User's Guide*.

5.70 Sigtran IPSP application on SLIC card (Release 46.3)

This feature allows for porting of the current IPSP application onto the Oracle Communications EAGLE Service and Link Interface Card (**SLIC**) (P/N 7094646). The SLIC operates with the same functionality as the E5-ENET-B (870-2971-01) card running the IPSP application.

See *Hardware Reference* for more information on the SLIC.

5.71 SIGTRAN Measurements Phase 1 (Release 38.0)

The SIGTRAN Measurements Phase 1 (SIGTRAN) feature allows measurements for the IPGWx and IPLIMx cards that are currently obtained using the EAGLE 5 ISS `pass` commands to be obtained through EAGLE 5 ISS measurement collection and reporting mechanisms. The SIGTRAN feature also obtains measurements for the IPSP cards that are introduced in Release 38.0.

Note:

The `pass` commands continue to be supported as a separate means of displaying the associated data.

On-demand measurement reports can be obtained through the User Interface or the Measurements Platform. Scheduled measurement reports must be obtained through the Measurements Platform.

The SIGTRAN feature provides measurement capabilities for the following protocols.

- UA
The UA protocol consists of a combination of the **M3UA** and **SUA** protocols. UA measurements are collected for IPGWx and IPSP cards per association (**ASSOC**) on the application server (**AS**).

 **Note:**

IPSG cards support only M3UA protocols.

Measurements for UA messages that are received without a routing context or with multiple routing context values are pegged to the default AS value and the appropriate **ASSOC**. The **RXMLRCMS** register is used to indicate the number of messages received with multiple routing context values. This register is always pegged using the default AS value. The AS value can also be set to the default AS for all UA data.

All UA data for IPSG cards is pegged against the default AS.

- SCTP
SCTP measurements are collected for IPGWx, IPLIMx, and IPSG cards per CARD and ASSOC.
- M2PA
M2PA measurements are collected on IPLIMx and IPSG cards per LINK.

5.71.1 Feature Control Requirements

There are no feature control requirements identified for this feature.

5.71.2 Hardware Requirements

The SIGTRAN feature requires SSEDCEM or E5-ENET cards.

 **Note:**

The **iplim** and **ss7ipgw** GPLs run on SSEDCEM cards. The **iplhc**, **ipghc**, and **ipsg** GPLs run on E5-ENET cards.

5.71.3 Limitations

The SIGTRAN Measurements Phase 1 feature has the following limitations:

- No new scheduled reports are available on the EOAM.
- SCTP measurements are not supported on the SEAS interface.
- If the active MASP boots during EAOM based measurement collection, then data for that period is lost.
- 120K LNP NPANxx, and 80K LNP LRN may not have the CPU bandwidth to collect additional measurements.
- The format of the existing COMP-LINK, MTCN-LINK, and MTCNTH-LINK reports on both the EOAM and the MCP has been modified. If these reports are passed to additional computer systems for automated parsing and analysis, then the software may have to be modified on the target systems to adjust to the changes.
- If an AS with the name default exists before upgrade, then accurate collection of measurement data for that AS cannot be guaranteed.

- The ACTIVE period for UI reports is not supported for any reports that are generated for the IPSP card.

5.72 Simplifying BIP (Board ID PROM) for EAGLE STP Boards (Release 23.1)

This feature changes the 7- and 8-digit serial numbers currently used to identify a board in the **EAGLE** to serial numbers that contain 7, 8, 11, 12, and 14 digits. The serial number is contained in the board **ID PROM** on each board in the **EAGLE**.

The 7- and 8-digit serial numbers are used on older systems and require no changes to support. The 11-digit serial number is presently used by Tekelec manufacturing, but was not fully supported by the **EAGLE** system software. The 12-digit serial number adds a special character to the serial number used by manufacturing. The 14-digit serial number uses four digits to show the year that the board was manufactured. All the serial number formats are compliant with the Year 2000 feature.

Table 5-18 shows the format of each of the five serial number formats.

Table 5-18 Serial Number Formats

Serial Numbers	Formats
7-digit serial number	ywwxxxx
8-digit serial number	yywwxxxx
11-digit serial number	nnnywwxxxx
12-digit serial number	nnnyww*xxxx
14-digit serial number	nnnyyyww*xxxx
y = year digit (0 - 9)	
w = week digit (0 - 9)	
n = product identifier digit (0 - 9)	
x = serial number digit (0 - F hexadecimal)	
* = special character (0 - 9, a - z, or A - Z, alphanumeric characters)	

Hourly Status Message Report

The indicator **INHAUDB** has been added to the Condition Type field of the Hourly Status Message Report. This indicator shows that the user has manually turned off the alarms for this device. The date and time that the alarm for the device was turned off is displayed in the report. The report also includes the alarm status periodic reminder added to the end of the report to summarize the status of the alarms.

Output Example

```
RLGHNCXA03W 97-06-07 15:00:00 EST Rel 22.0.0
5023.0000 REPT COND CARD
"CARD 1201:,MTCEINT-0,,97-06-07,14:58:24,,,,,"
"CARD 1202:0013,,SA,97-06-07,14:44:38,,,,**"
"CARD 1203:0013,,SA,97-06-07,14:44:38,,,,**"
"CARD 1204:0013,,SA,97-06-07,14:44:38,,,,**"
"CARD 1206:0013,,SA,97-06-07,14:44:38,,,,**"
```

```

"CARD 1207:0034,,NSA,97-06-07,14:52:56,,,,,* "
"CARD 1208:0013,,SA,97-06-07,14:44:38,,,,**"
"CARD 1216:0013,INHAUDB,NSA,97-06-07,13:44:38,,,,,"
"CARD 1101:0034,MTCEINT-0,NSA,97-06-07,14:52:56,,,,,* "
"CARD 1115:0143,,NSA,97-06-07,14:57:52,,,,,* "
;
RLGHNCXA03W 97-06-07 15:00:02 EST Rel 22.0.0
5034.0000 REPT COND ALARM STATUS
"ALARMS:INHIBITED,0,17,8"
"ALARMS:ACTIVE,2,0,0"
"ALARMS:TOTAL,2,17,8"
"ALARMS:STATUS,AUDIBLE,SILENT,SILENT"

```

The alarm status periodic reminder contains four fields, **ALARMS:INHIBITED**, **ALARMS:ACTIVE**, **ALARMS:TOTAL**, and **ALARMS:STATUS**.

The **ALARMS:INHIBITED** field shows the number of alarms of each type that have been turned off.

The **ALARMS:ACTIVE** field shows the number of alarms of each type that are active and not turned off.

The **ALARMS:TOTAL** field shows the total number of alarms of each type that the **EAGLE** has detected.

Following each of these fields are three numbers separated with commas. These numbers show the number of each alarm type the **EAGLE** has detected. The first number shows the number of critical alarms. The second number shows the number of major alarms. The third number shows the number of minor alarms.

The **ALARMS:STATUS** field shows whether the critical, major, and minor alarms are silent or audible.

In this example, the **EAGLE** has 17 major alarms and 8 minor alarms turned off, 2 critical alarms active for a total alarm count of 2 critical alarms, 17 major alarms, and 8 minor alarms. Only the critical alarms are audible.

5.73 Single Slot Enhanced DCM (Release 28.1) (IP⁷ Release 6.0)

The dual-slot **DCM** card (870-1945-03) occupies two slots on the **EAGLE**; the single slot **EDCM** (**SSEDCM**, 870-2372-01) card occupies only one slot. Unlike the **DCM Card**, the single slot **EDCM** card can be provisioned in any slot. Only **IPLIMx** and **IPGWx** applications are allowed to run on the single slot **EDCM Card**. The **DCM** card can always be hot-swapped with a single slot **EDCM** card.

Refer to the **NSD Hardware Manual** for current details of the **SSEDCM**.

Hardware Requirements

This release introduces a new **DCM** type family board called the Single Slot **EDCM** (**SSEDCM**). Just as the name implies, the **SSEDCM** card occupies only one slot in an **EAGLE** shelf, as opposed to the dual-slot **DCM** boards. The provisioning rules for a **DCM** type board allow provisioning of any slot where a **DCM** type board can physically be inserted.

5.74 SIP Application - FAX and MODEM URI Support and Configurable Thresholds (Release 46.0)

The SIP Application - FAX and MODEM URI Support and Configurable Thresholds feature adds support of FAX and MODEM as allowed schemes in SIP URI to perform Number Portability lookup on SIP INVITE message in the SIP application. The user can configure thresholds for the throughput limits. Alarms are raised based on the limits specified by the user.

5.75 SIP NP Feature SIPOPTS Enhancements

These SIP NP enhancements add new values GRNASD and RNGRNDN for the SIPOPTS Parameters RNFMT and NPRSPFMT to support new format options for the RN parameter and the Contact header URI in the SIP 302 response.

The `chg-sipopts` command was updated to support these enhancements.

See *SIP Number Portability Configuration* in *Database Administration – Features User's Guide* for more information.

5.76 SIP NP on SLIC Network Redundancy Enhancement (Release 46.5)

This feature introduces network communication redundancy on the SLIC card. Four network interfaces will support SIP - two for ExAP communication and two interfaces for signaling. One SLIC card running the SIP application can connect to two ExAPs and two signaling networks at the same time. Interface A/D is used for ExAP connectivity, and interface B/C is used for the signaling network.

Figure 5-20 SIP on SLIC Network Redundancy Model

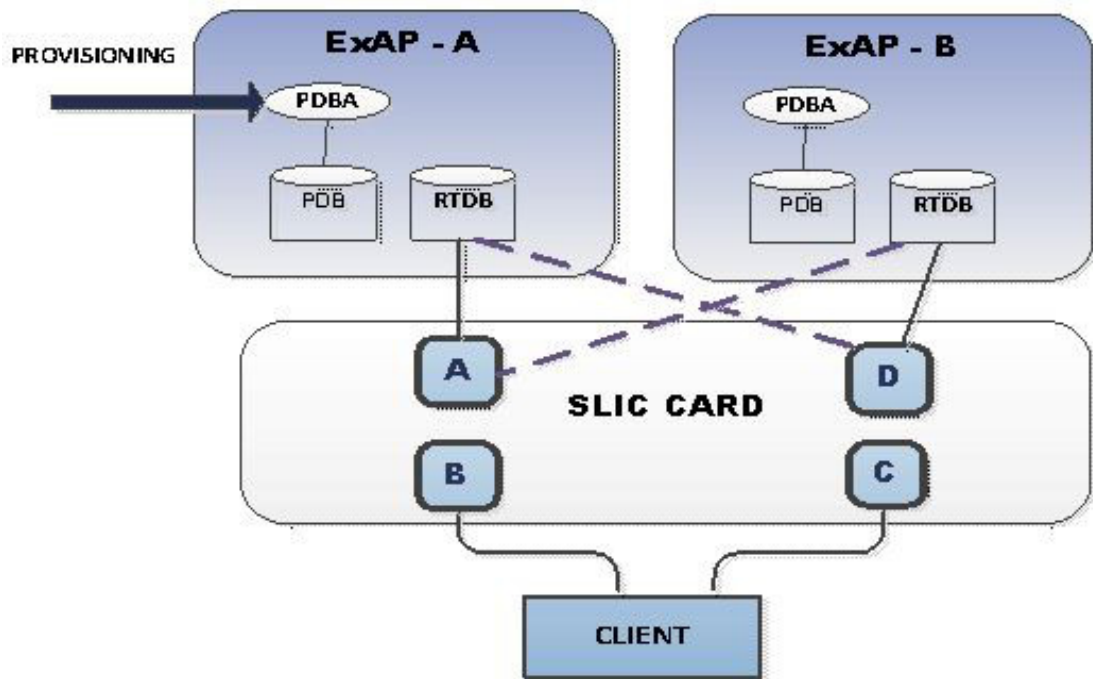

See *Database Administration - Features User's Guide* for more information.

5.76.1 Hardware

Ethernet Interface A and D are used for ExAP connectivity on SLIC cards.

Ethernet Interface B and C will be used for signaling network connectivity on SLIC cards.

5.77 SIP Number Portability (Release 45.0)

The SIP Number Portability feature provides SIP-based Number Portability using the RxDB (RIDB or RTDB) of the EAGLE. This feature adds a SIP interface to allow SIP NP requests to be received by an EAGLE card and processed by the RxDB. A response is then returned to the requestor. A new SIPHC GPL supporting a SIP stack over TCP is added. The new SIPHC GPL runs on E5-SM8G-B.

The EAGLE supports configuring SIP cards with EPAP, with ELAP, or with EPAP and ELAP on the same system. The SIP Number Portability feature can co-exist with all other EPAP-based and ELAP-based applications. The SIP cards handle only SIP traffic. No other SCCP traffic is handled by the SIP cards.

SIP Performance

- TCP is the supported protocol.
- The supported rate is 500 TPS per card. Sending unsupported SIP messages may degrade this rate.
- The maximum traffic supported per card is 500 TPS. A customer provided load-balancer may be required, in front of the STP SIP cards, in order to load-share the traffic between

the cards and the sites. For more information on load sharing, see the "SIP Redundancy" section in *Database Administration Manual - Features*.

- Card Protection/Traffic Protection is not guaranteed and may have unpredictable results if the traffic exceeds 500 TPS.

 **Note:**

A UIM 1439 will alarm if SIP card reaches or exceeds 100% of capacity.

5.77.1 Feature Control Requirements

- FAK for Part Number 893-0406-01
- The feature cannot be turned off after it has been turned on.

5.77.2 Hardware

The SIPHC GPL allows only E5-SM8G-B cards to be provisioned as Service Module cards. If any card other than an E5-SM8G-B card is plugged into a card slot configured as SIPHC GPL, the card will be auto-inhibited.

5.78 SIP Stack Improvements (Release 46.0)

The SIP Stack Improvements feature replaces the existing SIP stack with a faster and more stable SIP Stack into EAGLE.

5.79 SLAN on E5-ENET Assembly (Release 37.0)

Description

The SLAN on E5-ENET Assembly feature supports running the **stplan** application on the E5-ENET card.

The SLAN on E5-ENET Assembly feature allows the E5-ENET card to support the features currently implemented on the DCM card (SSEDCM, or EDCM-A assembly).

The E5-ENET card running the **slanhc** GPL and the **stplan** application is referred to as the E5-SLAN card.

 **Note:**

The DCM, SSEDCM, EDCM-A, and E5-SLAN cards run the **stplan** application. The **vwxslan** application is no longer used.

Because the DCM card and the E5-SLAN card are both provisioned with card type **dcm** and the **stplan** application, the two cards can be "hot-swapped" without re-provisioning the card information in the system.

**Note:**

Hot-swapping the DCM and E5-SLAN cards requires cable adaptors.

HIPR cards must be installed in each shelf where E5-SLAN cards are installed. At least two cards running the **stplan** application must be provisioned in the EAGLE 5 ISS to provide “n+1” redundancy. A maximum of 32 STPLAN/E5-SLAN cards can be provisioned.

If a shelf contains HMUX cards, then E5-SLAN cards must be provisioned in shelves adjacent to that shelf. The optimum configuration is to provision half of the E5-SLAN cards in the previous shelf and half in the next shelf.

The SLAN on E5-ENET Assembly feature allows the link speed and duplex configuration to be set either automatically or manually. The `auto` parameter in the `ent-dlk` command can be set to `yes` to enable auto-negotiation, which configures speed and duplex for the link automatically. The `duplex` and `speed` parameters in the `ent-dlk` command can be used to set duplex and speed manually.

If auto-negotiation is enabled, the E5-SLAN card operates at 12,000 TVG grants per second when the IP port operates at 100 Mbps full duplex, and at 1200 TVG grants per second when the IP port operates at 10 Mbps full or half duplex, or 100 Mbps half duplex.

Thermal management and alarming provisions are provided for the E5-SLAN card.

Feature Control Requirements

None.

Hardware Requirements

The SLAN on E5-ENET Assembly feature has the following hardware requirements:

- HIPR cards must be installed at card locations 9 and 10 in the shelf where the E5-SLAN card is installed.
- Backplane cable adaptors

Limitations

- The `-m`, `-p`, and `-h` suboptions of the `-d` option for the `netstat` command are not supported for the E5-SLAN card.
- The E5-SLAN card does not preserve memory across boots. The application will not remain intact across card boots.
- The performance of the E5-SLAN card is limited by the data rate of the Ethernet port and the capability of the external LAN/WAN.

5.80 SLS Bit Rotation on Incoming Linkset (Release 40.0)

The SLS Bit Rotation on Incoming Linkset (**ISLSBR**) feature allows the EAGLE 5 ISS to rotate the 4 least significant bits (LSBs) of the signaling link selection (SLS) field, according to the linkset of the incoming message. This ability allows traffic to be fairly distributed across links and linksets. If selected, this rotation applies to all ITU and ANSI messages.



Note:

ANSI messages use a 5 or 8 bit SLS value. This feature allows bit rotation for only 4 of the bits.

This feature modifies only the link selection algorithm. The value of the SLS field is not changed.

SLS Bit rotation is performed only once for an ITU message. If both incoming and outgoing SLS rotation is selected for an ITU message, then incoming SLS rotation takes precedence over outgoing SLS rotation.

5.80.1 Feature Control Requirements

The ISLSBR feature has the following feature control requirements:

- FAK for part number 893-0265-01
- A temporary FAK cannot be used to enable the feature.
- The feature cannot be turned off after being turned on.

5.81 SMSREQ Handling for Migrated or Ported Subscribers (Release 41.1)

The A-Port, IGM, MNP CRP, and MT-based IS41 SMS NP features are enhanced to support MTP-routed SMSREQ messages. If the SMSREQ message cannot be processed by any of these features, then the SMSREQ is MTP routed.

5.82 SMS-MO Blocking SCCP Spoofing (Release 46.3)

The SMS-MO Blocking SCCP Spoofing feature allows a consistency check between the SCA (service center address) in the SCCP part and SMRPDA/SMRPOA in the MAP part in order to manage and prevent SMS fraud. These validations are provisioned using MAP parameter based routing above the existing TCAP based Routing and FLOBR.

5.83 SNMP Interface on EPAP (EPAP 16.0)

With the SNMP Interface on EPAP feature, the EPAP can be managed directly by an Element Management System (EMS) in the standard SNMP interface. The SNMP Interface on EPAP feature supports the following:

- Configuration of EMS is allowed with various parameters from the `epapconfig` utility.
- The EPAP sends SNMPv2c trap messages to the configured EMS on the basis of the configurable parameter `SNMP Alarm Feed`. If `SNMP Alarm Feed` is set to *on*, the traps are sent to the EMS. If `SNMP Alarm Feed` is set to *off*, the traps are not sent to the EMS. SNMP trap messages can be sent to a maximum of five EMSs.

- The EMS can receive and set the value of one MIB element *resyncVar*.
- The EMS can resynchronize its alarm database with the active alarms on the EPAP by sending a SET request to the EPAP to set the object value of *resyncVar* to 1.

All alarms can be reported via this SNMP Northbound Interface. Visual alarms are allowed in the GUI, and also reported via the SNMP Northbound Interface.

5.84 SNMPv3 support for interface towards OCEEMS (Release 16.2)

EPAP supports SNMPv3 security enhancement and user/group management, secure alarm synchronization with SNMPv3 Oracle Communications EAGLE Element Management System (OCEEMS), and traps tailored to SNMPv3. This version of the protocol introduces enhanced encryption and secured authentication mechanisms.

EPAP will interact with OCEEMS or other Network Management Systems (NMS) in the SNMP interface to send traps in SNMPv3 as well as existing the SNMPv2c mode. It also provides security services by User-based Security Model (USM) and View-based Access Control Model (VACM) in SNMPv3 mode.

Enhancement from SNMPv2c to SNMPv3 include:

1. SNMP global mode - EPAP provides three different modes for SNMP support:
 - SNMPv2c only
 - SNMPv3 only
 - Both SNMPv2c and SNMPv3
2. SNMP configuration with various parameters from the epapconfig menu
3. Trap forwarding to OCEEMS in the format of SNMPv3 as well as the existing SNMPv2c
4. Alarm resynchronization between EPAP and OCEEMS in the format of SNMPv3 as well as the existing SNMPv2c:
 - Supports SNMP GET and SET of the *resyncVar* **MIB** element
5. SNMP v3 security model support:
 - SNMPv3 views (Read/Write for EPAP MIB variables), groups and users management

See *Administration Guide* for more information.

5.85 Spare Point Code (Release 31.12)

The **EAGLE** ITU International/National **Spare Point Code** feature allows a network operator to use the same Point Codes across two networks (either **ITU-I** or **ITU-N**). The feature also enables National and National Spare traffic to be routed over the same linkset. The **EAGLE** uses the **MSU** Network Indicator (**NI**) to differentiate the same point code of one network from the other. In accordance with the **SS7** standard, unique Network Indicator values are defined for **ITU-I**, **ITU-N**, **ITU-I Spare**, and **ITU-N Spare Point Code** types.

The **EAGLE** currently provides full support for four types of point codes:

- **ANSI**, ITU-National (**NI**=10binary)
- **ITU-National** 24-bit

- **ITU-International (NI=00 binary)**
- **ITU National Spare PCs (NI=11 binary)** can be primarily supported via a combination of the following two items:
 1. Support for **ITU-National Spare** can be set on a per linkset basis using the linkset **NIS** parameter. If set, the **EAGLE** will allow receipt of messages with **NI=11binary** on the designated linkset and will force all outgoing messages on that linkset to have **NI=11binary**.
 2. The Duplicate **Point Code** routing feature, combined with the **Multiple Point Code Support** feature, can be used to create a separate routing group for a National **Spare Point Code** network.

While these two functions can be combined to support **ITU National Spare Point Code** routing, there are limitations described as follows:

- The **EAGLE** cannot distinguish between messages with different network indicators received over the same linkset. For example, the **EAGLE** will route a message with **DPC = 1-1-1 (NI=10binary)** the same way as a message with **DPC = 1-1-1 (NI=11binary)**.
- Forcing the user to use the Duplicate **PC** Routing feature requires that all linksets in the system be placed in one of the defined groups.

The **Spare Point Code** Support feature addresses the above limitations. by The feature provides a new **PC** sub type named Spare. The spare point code supports the **ITU-N Spare** and **ITU-I Spare Point Code** feature.

Additionally, this feature requires a single linkset to support multiple outgoing network indicators (e.g. 11 binary, 00 binary). In turn, messages are routed according to the **Point Code** on the outgoing node that corresponds to the associated network indicator.

Limitations

1. This feature does not allow the **EAGLE** to **MTP** convert between National and National Spare Point Codes. Likewise, this feature does not allow the **EAGLE** to **MTP** convert between International and International Spare Point Codes.
2. In the destination table, an **ITU-I** alias and an **ITU-I Spare** alias cannot be defined for the same **Point Code**, likewise an **ITU-N** alias and an **ITU-N Spare** alias cannot be defined for the same point code
3. The feature is not supported on the **SEAS** interface. Spare point codes are only supported for **ITU** point codes, and **SEAS** only supports **ANSI** point codes. Any Private **ANSI** point code provisioned using the standard **EAGLE** command line interface is not displayed by the **SEAS VFY-** command.
4. **ITU National** and **ITU National Spare Point Code** are implemented as separate network domains that can co-exist within the same **STP**.
5. Spare point codes are not supported for **IPGWI** sockets using **TALI** protocols. The spare point code feature may not be enabled if any application sockets have been provisioned on **IPGWI** cards.
6. The existing implementation of **Gateway Screening** does not support Group Code (Duplicate Point Codes). **Gateway Screening** will also not support **PPCs**.
7. The **Spare Point Code** and **PPC** prefix value, s- and p- do not apply to domain type point codes for **ANSI** and **ITU-N24**.

8. **ITU-N** and **ITU-N24** Point Codes cannot co-exist as **SID Destination** True Point Codes and therefore **ITU-N** Spare and **ITU-N24** Point Codes cannot coexist as **SID Destination** True Point Codes.
9. A single **STPOPTS** value (cnvcgdi) will be used to control message handling for **ITU-I** and **ITU-I** Spare messages when the **CgPA PC** does not have a required alias
10. A single **STPOPTS** value (cnvcgdn) will be used to control message handling for **ITU-N** and **ITU-N** Spare messages when the **CgPA PC** does not have a required alias
11. The existing implementation of the **SRVSEL** command interface to the **SRVSEL** table does not provide a way to separate **MSU** traffic for different **ITU** National Group Code networks. Therefore no provision is made for the **SRVSEL** command to control the separation of **ITU** spare and non-spare traffic. The **SRVSEL** table applies to the **EPAP** based features **G-FLEX**, **INP**, **G-PORT**, **SMS** Prepaid, and **IS-41** to **GSM** Migration. Likewise, no provision is made for the **GTTSEL** command interface to the **GTTSEL** table to allow separation of **ITU** spare and non-spare traffic for **EGTT**, **VGTT** and **MGTT**.

5.86 Split Allowed CGPA Table (Release 22.0)

The Allowed **CGPA** screen has been changed in Release 22.0 to allow for different next screening values depending on the value of the routing indicator (ri) parameter. These options are summarized in [Table 5-19](#).

Table 5-19 Next Screening Options for the Allowed CGPA Screen

RI	NSFI
GT, *	STOP, TT
DPC, *	STOP, CDPA

The messages can be screened on the routing indicator (**RI**) field. In previous releases, the routing indicator was included in the Allowed **CGPA** screening entry, but was not part of the screening process. This allowed only one message routing indicator value, or range of values, for each Allowed **CGPA** entry with a specific *sr/ni/nc/ncm/sccpmt/ssn* parameter combination. In Release 22.0, different routing indicator values can be specified for an **Allowed SIO** entry with a specific *sr/ni/nc/ncm/sccpmt/ssn* parameter combination, along with different next screening values for each entry. For example, the **Allowed SIO** screen in Release 22.0 can contain the following entries.

Output Example

```

RLGHNCXA03W 97-06-07 15:58:16 EST Rel 22.0.0
SCREEN = ALLOWED CGPA
SR   NI      NC      NCM      SSN      RI      SCCPMT  NSFI     NSR/ACT
IEC  240     001     010     012     DPC    017     CDPA     NSR1
IEC  240     001     010     012     GT     017     TT       NSR2

```

5.87 Split of Allowed SIO Table (Release 22.0)

The **Allowed SIO** screen has been changed in Release 22.0 to allow for different next screening values depending on the value of the service indicator (si) parameter. These options are summarized in [Table 5-20](#).

Table 5-20 Next Screening Options for the Allowed SIO Screen

SI	NIC	PRI	H0	H1	NSFI
00	single value or wildcard	single value, range, or wildcard	single value, range, or wildcard	single value, range, or wildcard	DESTFLD, DPC, BLKDPC, STOP
01, 02	single value or wildcard	single value, range, or wildcard	single value, range, or wildcard	single value, range, or wildcard	DPC, BLKDPC, STOP
03	single value or wildcard	single value, range, or wildcard	Not Specified	Not Specified	CGPA, CDPA, DPC, BLKDPC, STOP
04 - 15	single value or wildcard	single value, range, or wildcard	Not Specified	Not Specified	DPC, BLKDPC, STOP

Also in Release 22.0, messages can be screened on the message priority (PRI) field. In previous releases, the message priority was included in the **Allowed SIO** screening entry, but was not part of the screening process. This allowed only one message priority value, or range of values, for each **Allowed SIO** entry with a specific `sr/si/nic/h0/h1` parameter combination. In Release 22.0, different message priority values can be specified for an **Allowed SIO** entry with a specific `sr/si/nic/h0/h1` combination, along with different next screening values for each entry.

5.88 S-Port Subscriber Differentiation (Release 42.0)

The Service Portability (**S-Port**) Subscriber Differentiation feature allows multiple routing numbers to be provided for a subscriber. This functionality allows different processing to be performed on different groups of subscribers.

This feature uses the Additional Subscriber Data (**ASD**) as the subscriber's private routing number (for message relay features) and the Generic Routing Number (**GRN**) as the subscriber's public routing number (for query/response features). If ASD is not provisioned, then subscribers follow standard S-Port processing using the GRN.

The feature overrides the S-Port application of the GRN by using the ASD, if present, for call flows resulting in message relay.

5.88.1 Feature Control Requirements

- FAK for Part Number 893-0379-01
- The S-Port feature (Part Number 893-0343-01) must be enabled before the S-Port Subscriber Differentiation feature can be enabled.
- A temporary FAK cannot be used to enable the S-Port Subscriber Differentiation feature.
- The S-Port Subscriber Differentiation feature cannot be turned off after it has been turned on.
- The INP feature (Part Number 893-0179-01) with the MR service, Info Analyzed Relay Number Portability feature (Part Number 893-0261-01), MO-based GSM SMS NP feature (Part Number 893-0194-01), MO-based IS41 SMS NP feature

(Part Number 893-0195-01), or Prepaid IDP Query Relay feature (Part Number 893-0160-01) must be turned on before S-Port Subscriber Differentiation processing can occur.

5.89 SS7 Firewall Enhancements (Release 46.6)

The SS7 Firewall Enhancements feature is a combination of several enhancements for the SS7 Firewall feature. These enhancements include the following:

- Display GTTSETIDX in RTRV-GTTSET command - Adds GTT set index (setdix) column to the `rtrv-gttset` command output. This allows GTT set information to be retrieved based on the GTT index number. Up to 7 setdix can be specified in the list.
- GTT Per Path Measurement feature enhancement -
- RTRV-GTA should allow any combination of PKGTYPE, ACN, and OPCODE - The `rtrv-gta` command allows any combination of the `pkgtype`, `acn`, and `opcode` parameters.
- Segmented XUDT first segment support in TOBR and MAP Based Routing - The TOBR feature is able to decode a partial TCAP segment in the first segment of a segmented XUDT message. It will try to decode the TCAP package Type with the ACN or Opcode, or both, and apply the TOBR feature on that MSU.
- Traffic volume measurements on individual rules/GTTSets - Introduces two (2) measurement registers per GTTSet. One register shows MSUs that don't have any matching rule. The second shows all MSUs for which a matching rule was found and the rule has the option to count MSUs.
- Treat differently by SCCP message type - Provides the ability to apply separate routing or security rules based on the SCCP message type.

5.90 SS7 Firewall on EAGLE (Release 46.3)

The SS7 Firewall feature provides a set of capabilities to monitor, throttle or validate messages. This feature enhances the existing FLOBR/TOBR/GTT Actions framework to support more parameters in the selection criteria (DN, IMSI, VLR Nb, etc.). This feature also creates a new logging engine to feed a "Network Security" log and adds Throttling to a destination feature.

See *Database Administration - GTT User's Guide* for more information.

5.90.1 Hardware

The SS7 Firewall Logging functionality is supported on the E5-ENET-B card. A maximum of 5 IPS cards can be configured per EAGLE. A maximum of 2 IPS cards are allowed to be provisioned as SFLOG type.

Logging IPS cards will use Ethernet Interface Port A for IP connectivity.

5.91 SS7 Firewall - Stateful Applications (Release 46.6)

SS7 Firewall - Stateful Applications allows the Signaling Transfer Point (STP) to validate the messages coming in for a subscriber roaming out by validating them against the Visitor Location Register (VLR) the subscriber was last seen by the Home Location Register (HLR). Once the HLR provides a validity of the new VLR, the EAGLE then lets the message into the

network. If the message is not validated, it is handled per configuration (either silent discard, fallback, or respond with error).

The interaction of the Stateful Applications card in EAGLE is depicted in the following figure. The message forwarding from LIM to SFAPP cards will only work with IPSG+GTT SLIC cards. For IPSG-only SLIC cards, messages will be forwarded to the SCCP cards, which will then forward the message to the SFAPP SLIC cards:

Figure 5-21 Call Flow for VLR Validation

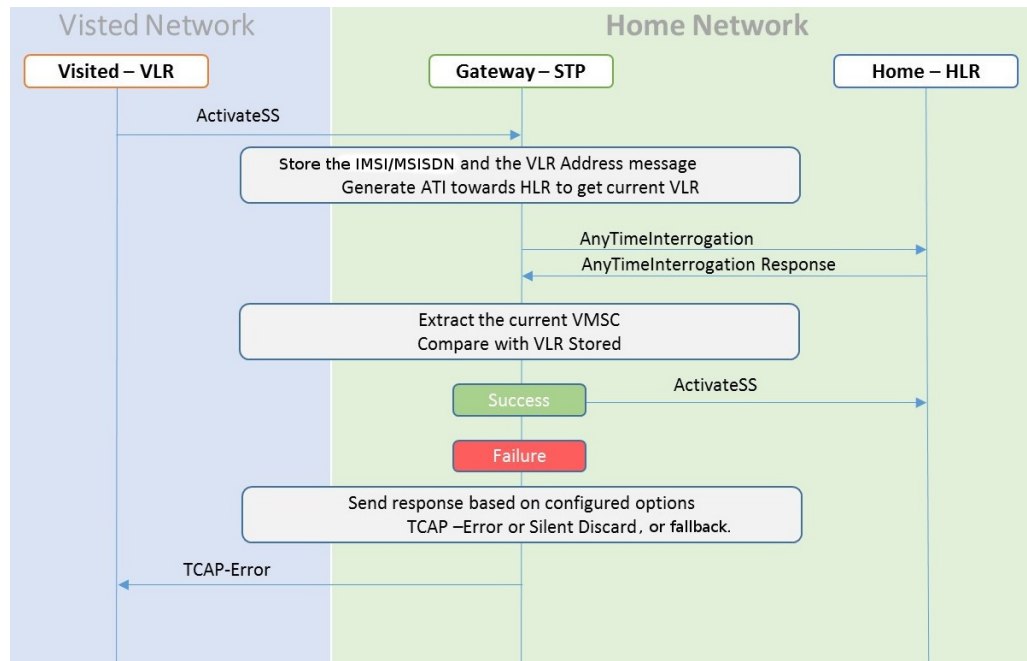

As seen in the previous figure, VLR Validation uses the information stored in the HLR about the current VLR to validate the VLR from which the message is received.

Figure 5-22 Call Flow for Velocity Check Using ATI

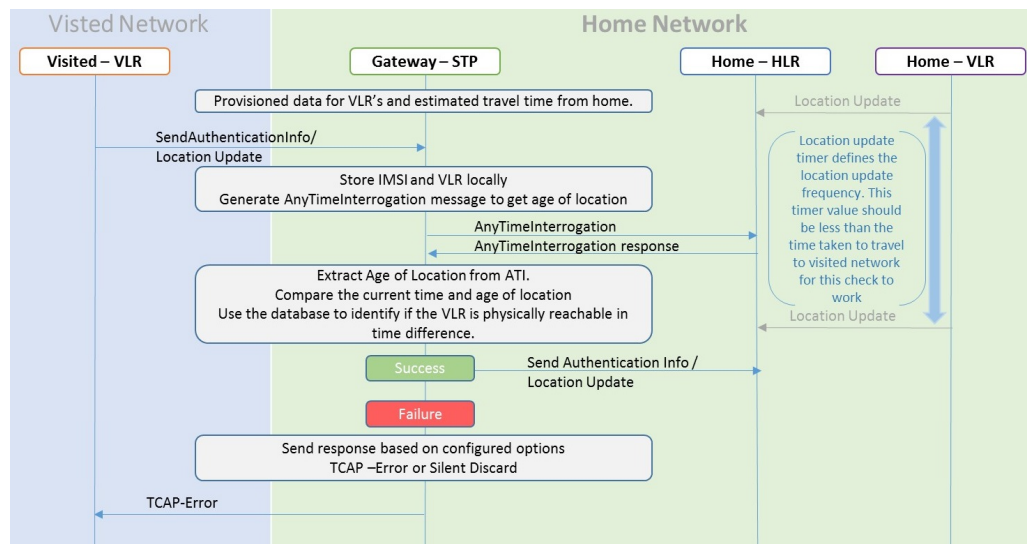

As seen in the previous figure, Velocity Check using ATI uses the information stored in the HLR about the current VLR and the age of location parameter to identify if the new VLR is reachable from the current VLR, stored in HLR.

This use case is dependent on the validity of the information stored in the VLR and the T3212 timer (periodic update location timer). In case the time distance between two networks is less than the value of T3212 timer configured for the network, this use case test would provide false positives.

See *Stateful Applications User's Guide* for more information.

5.91.1 Hardware

SS7 Firewall - Stateful Applications is only compatible with SLIC hardware.

SS7 Firewall - Stateful Applications is only supported on the 64-bit flash GPL.

5.92 SS7 Firewall (Stateless Screening Enhancements) (Release 46.6)

The SS7 Firewall (Stateless Screening Enhancements) feature adds support for the following operations in MAP Based Routing:

- PurgeMS
- RestoreData
- Reset
- RegisterSS
- USSD-Request
- USDD-Notify
- SAI
- CheckIMEI
- PSL
- SubscriberLocationReport
- UpdateGPRSLocation

This feature also adds support for IMEI as a parameter. See *Database Administration - GTT User's Guide* for more information.

5.93 SS7 Message Rejection Due to Screening (Release 22.0)

The **EAGLE** produces these **UIMs** to alert the user that an **MSU** has been discarded because of gateway screening.

UIMs

- **UIM 1005** — **GWS** rcvd **OPC** that is not allowed
- **UIM 1006** — **GWS** rcvd **DPC** that is not allowed
- **UIM 1007** — **GWS** rcvd **OPC** that is blocked

- **UIM 1008** — **GWS** rcvd **DPC** that is blocked
- **UIM 1009** — **GWS** rcvd **SIO** that is not allowed
- **UIM 1010** — **GWS** rcvd a priority that is not allowed
- **UIM 1011** — **GWS** rcvd **TFC**, **AFTPC** not in routing tbl
- **UIM 1012** — **GWS** rcvd Clg Party that is not allowed
- **UIM 1013** — **GWS** rcvd Cld Party that is not allowed
- **UIM 1014** — **GWS** rcvd **Translation Type** not allowed
- **UIM 1015** — **GWS** rcvd **SCMG** with not allowed **AFTPC**

These messages cannot be received at the **SEAC** unless the **SEAS** port is configured to receive unsolicited system maintenance messages. In release 22.0, when any of these **UIMs** are generated, the **REPT-SCRREJ** message is sent to **SEAS**, regardless of the configuration of the **SEAS** port to alert the user at the **SEAC** that the **EAGLE** has discarded an **MSU** because of gateway screening.

This feature allows the user to limit how many of these **UIMs** are sent to the **EAGLE** terminals and how many **REPT-SCRREJ** messages are sent to **SEAS**. This limit is configured with the `set-scrrej-prmtrs` command to control the number of **UIMs** sent to the **EAGLE** terminals, and with the **SET-SCRREJ-PRMTRS** command function on the **SEAS** interface to limit the number of **REPT-SCRREJ** messages are sent to **SEAS**.

5.94 SS7 over High-Speed Signaling Link (Release 23.0)

The **ATM** high-speed signaling link feature introduces signaling links transmitting at 1.544 Mb/s. Before Release 23.0, the fastest transmission speed on a signaling link was 64 kb/s. This feature uses the **ATM** (asynchronous transfer mode) protocol to implement this feature. **ATM** is a specific packet-oriented transfer mode that uses an asynchronous time-division multiplexing technique to multiplex information flow in fixed blocks called cells.

Tekelec's implementation of **ATM** differs from the Bellcore **ATM** model in these ways.

- The **AAL5CP** protocol support (primarily segmentation and reassembly of user data **PDUs**) is provided by the hardware, from the **AATM** applique of the high-speed **ATM** signaling link card, not from the software. The **AATM** applique also provides **CRC10** support for **OAM F5 ATM** cell flows.
- The **ATM** driver is not a defined block in the protocol model, but is needed in the Tekelec implementation to control and interface with the **AATM** applique. The **ATM** driver provides the software interface to the **AAL5CP** hardware functionality. The **ATM** driver also provides the **ATMM** (**ATM** layer management) functions that are supported in the **EAGLE**.
- As a part of providing new **ATM** (**MTP**-level 2 equivalent) functions into the existing **EAGLE** software (based on **MTP-3** and **MTP-2**, not **MTP-3** and **SAAL**), some of the interfaces to and from **MTP** level 3 are to and from the **MAAL** (management **ATM** adaptation layer), rather than the **SSCF** (service specific coordination function) handling all **MTP-3** interaction.

5.95 SS7-Over-IP Gateway for Point-to-Point Links (IP7 Release 1.0)

This feature allows the use of an **IP** network in place of point-to-point **SS7** links to carry **SS7 MSUs**. For example, the C links between a mated pair of **STPs** or B/D Quad links between **STPs** can be replaced by an **IP** transport network with gateway **STPs** deployed on both ends of the link. The gateway converts the **SS7 MSUs** to **IP** packets on one end of the link and **IP** packets to **SS7 MSUs** on the other end of the link. Full **MTP** level 3 functionality is provided with this feature.

Figure 5-23 STP Connectivity via MTP over IP

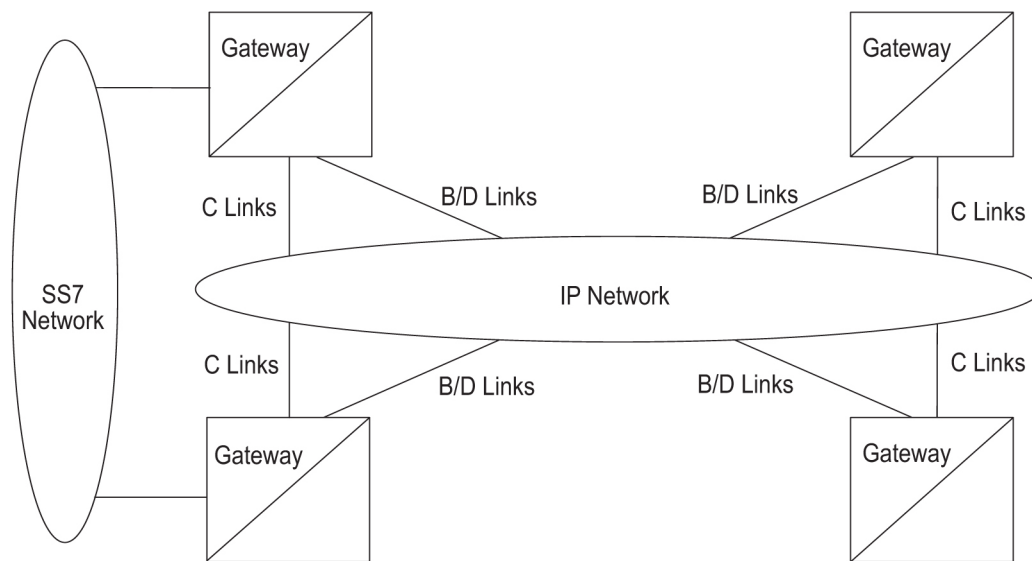

This feature provides single **TCP/IP** point-to-point connectivity by way of a new **GPL**, **IPLIM**, running on the **DCM** which, together with the hardware, provides a **TCP/IP** point-to-point connection to carry **SS7** traffic.

To provide point-to-point connections, a number of administration steps must be performed, as follows:

- Links, link sets, destinations, and routes to those destinations via the existing **EAGLE SS7** administration capabilities must be configured.
- Socket connections that should be created at each **IPLIM** card must be configured.

Unlike the point-to-multipoint configuration, the user is not required or allowed to configure **SS7 Routing Key** associations for **IPLIM** socket connections. A single socket exists on the **DCM** card running the **IPLIM** application. All **SS7** traffic is carried over the single socket.

5.96 SS7 SCCP-User Adaptation Layer (SUA) Request for Comment (RFC) (Release 31.10)

The current **SUA** Draft Version 3 support on the **IPGWx GPL** will be enhanced to comply with **SUA RFC** with the following feature highlights:

- **SUA** Draft Version 3 support on the **IPGWx GPL** is **REPLACED** with support for **SUA RFC**
- Support **SCCP** Connectionless messages via **SUA CLDT** and **CLDR**. Connection Oriented messages are not supported
- Support **SUA Signaling Network Management** Messages
- Limited support for Routing Context - up to 4 Routing Contexts per **ASP (SUA and M3UA)**.

Hardware Requirements

The **EDCM** (single-slot) P/N 870-2372-01 Rev E is required for **SUA RFC**.

Limitations

- The version of **SUA** implemented in this release is **NOT** backward compatible with the **SUA** version currently available on **EAGLE** releases.
- Only the Connections Message transfer part of the **SUA** protocol is supported for class 0 and class 1 **SCCP** messages.
- Limited support for Routing Context - up to 4 Routing Contexts per **ASP (SUA and M3UA)**.
- To remove a routing context from a routing key, the routing key must be deleted and re-entered.

5.97 Standalone PDB on EPAP (EPAP 16.0)

This enhancement allows the EPAP to operate in a standalone mode with only the Provisioning Database (PDB). An EPAP operating in standalone or PDB-only mode runs on a single E5-APP-B server. Geographical redundancy is permitted, which allows the Active and Standby PDB in different locations. An EPAP can operate without a local mate. This enhancement also increases the PDBI performance.

EPAP operating both PDB and Real-time Database (RTDB), or Mixed EPAP, continues to be available. EPAP operating in standalone mode, or PDB-only mode, is optional and must connect to a non-provisioning EPAP with RTDB to load the EAGLE Service Module cards. The PDB-only EPAP software supports all interfaces currently available in Mixed EPAP configurations related to PDB or Operations and Maintenance (O & M). Both mixed EPAP mode and standalone (PDB-only) mode support a maximum of 22 non-provisioning sites (44 servers). When PDB and RTDB coexist on the provisioning EPAP pair, the limit increases to 48 servers.

5.98 STC on E5-ENET Assembly (Release 37.0)

Description

The STC on E5-ENET Assembly feature supports the use of the E5-ENET card as an STC card running the **eroute** application.

The STC on E5-ENET Assembly feature allows the E5-ENET card to support the functions currently implemented on the STC card (SSEDCM, DCM, or EDCM-A assembly) for the EAGLE 5 Integrated Monitoring Support feature.

The E5-ENET card running the **erthc** GPL and the **eroute** application is referred to as the E5-STC card.

Because the SSEDCM STC card and the E5-STC card are both provisioned with card type stc and the eroute application, the two cards can be “hot-swapped” without re-provisioning the card information in the system.



Note:

Hot-swapping the SSEDCM and E5-STC cards requires cable adaptors.

A minimum of two cards running the eroute application must be provisioned in the EAGLE 5 ISS to support the EAGLE 5 Integrated Monitoring Support feature (“n+1” to provide redundancy). A maximum of 32 STC/E5-STC cards can be provisioned.

HIPR cards must be installed in each shelf where E5-STC cards are installed.

If a shelf contains HMUX cards, then E5-STC cards must be provisioned in shelves adjacent to the shelf that contains the cards being monitored. The optimum configuration is to provision half of the E5-STC cards in the previous shelf and half in the next shelf.

If IP signalling links are being monitored, then only single-slot STC cards can be provisioned. HIPR cards must be used in the shelves where the IP links are located.

The E5-STC card operates at 12,000 TVG grants per second when the IP port operates at 100 Mbps full duplex, and at 1200 TVG grants per second when the IP port operates at 10 Mbps full or half duplex, or 100 Mbps half duplex. The E5-STC card is preconfigured to use auto-negotiation to set duplex and speed automatically.

Thermal management and alarming provisions are provided for the E5-STC card.

Feature Control Requirements

None.

Hardware Requirements

The STC on E5-ENET Assembly feature has the following hardware requirements:

- Two HIPR cards must be installed in the shelf where the E5-STC card is installed.
- Backplane cable adaptors

Limitations

The STC on E5-ENET Assembly feature has the following limitations:

- The suboptions **{-m, -p, -h}** of the **-d** option for the `netstat` command are not supported for E5-STC card.
- The E5-STC card does not preserve memory across card boots: therefore, the application does not remain intact across card boots.
- The performance of the E5-STC card is limited by the data rate of the Ethernet port and the capability of the external LAN/WAN.

5.99 STP LAN Feature (Release 20.0)

The **EAGLE STP LAN** feature allows the **EAGLE** to support a **TCP/IP** connection from any interface shelf to external hosts. Message signal units (**MSUs**) processed by the **EAGLE** can be copied and directed through the **LAN** interface to an external server or microcomputer application.

The **STP LAN** feature is an optional feature that is off by default. To use the **STP LAN** feature, it must be turned on by entering the appropriate command. Once this feature is turned on, it cannot be turned off.

This feature requires a new circuit card, the application communication module (**ACM**) card. The **ACM** card provides an Ethernet interface at the interface shelf backplane and the processing power required to support message encapsulation and **TCP/IP** support.

The Ethernet connection uses an adapter that is connected to a single port media access unit (**MAU**). The **MAU** is attached to the backplane interface connector of the **ACM** and supports standard Ethernet function.

From the **MAU**, the user may attach any compatible host system. The host system must be using **TCP/IP** as the higher layer protocol and must support 10BASE2 Ethernet as the transmission method.

The **EAGLE** software on the **ACM** card receives **SS7 MSUs** from the **LIMs** and **ASM-SCCP** cards and copies those **MSUs** into memory on the **ACM** card. The copied **MSU** is encapsulated and transmitted using **TCP/IP** packets and Ethernet to the host computer. The host computer is responsible for reassembling the original message and processing the data.

This feature is designed to provide an open system architecture, allowing third parties to design applications that can be attached as adjuncts to the **EAGLE STP**.

The gateway screening feature provides a copy function. When an **MSU** passes all screening criteria, the **MSU** is allowed to pass through the **EAGLE STP** out to the **SS7** network. With the copy function, the **MSU** is copied, and the copy is sent through the **STP LAN** interface to a host application. This allows the host to track which **MSUs** from an external network were allowed to pass through the **EAGLE**.

The entire **MSU** is copied, including the **MTP**, which allows the host application to process the entire message. Total octet counts, including **MTP** level 2 and level 3, can be tallied and used for a variety of external measurements.

Messages from an X.25 signaling link reflect the translated message. The message is passed to the interface, and the screening and copy functions for an X.25 packet are

invoked, after the **EAGLE** has completed protocol conversion. The result is an **SS7** message that can be processed by the external application.

One **ACM** card is capable of servicing a maximum of 30 link interface modules (**LIMs**), regardless of the **LIM** type. This allocation is determined by the **EAGLE**'s internal load balancing algorithm that is capable of reassigning **LIMs** to other **ACM** cards in the event an **ACM** card should fail, or if the traffic rate to a single **ACM** changes significantly.

Typically you should provision extra **ACM** cards for redundancy. By provisioning extra **ACM** cards, the load balancing software ensures that when an **ACM** card fails, the **LIMs** assigned to the failed **ACM** card are reassigned to another **ACM** card, providing it has been configured. The **EAGLE STP** can support up to 32 **ACM** cards.

The **IP** addresses of adjacent hosts are entered into the **EAGLE** by using the **EAGLE** database administration commands. The **EAGLE** also provides load balancing for all **ACM** cards. A threshold is set through the database administration commands for each card, which determines when the **EAGLE** begins shedding traffic from the specified **ACM** card and redistributes that traffic to another **ACM** card.

This method of load balancing allows the user to configure each **ACM** card with a threshold, and provides an automatic mechanism by which traffic can be evenly distributed over multiple **ACM** cards. In addition to load balancing, this feature also reassigns traffic when an **ACM** card fails, so that all traffic can still be supported even when an **ACM** card fails. The **ACM** cards are capable of handling approximately 400 messages per card.

5.100 STPLAN Port to DCM (Release 26.0)

This feature ports existing **STPLAN** functionality to the **DCM (Database Communications Module)** hardware platform. The **DCM** provides the **EAGLE** with two 10/100 Base-Tx **IEEE 802.3/Ethernet** ports capable of carrying **IP** traffic.

This feature provides:

- the same functionality as **STPLAN** on **ACM**
- the same command interface
- the same network interfaces (single 10BaseT port; no 100BaseT)
- the same provisioning rules as for the **ACM**

Note:

The **DCM** is **NOT** a drop-in replacement for **ACM**. If a **DCM** is used as a replacement for an **ACM** card, the replacement is not a “plug-in” type replacement. The **STPLAN** card and datalink must be reprovisioned. Also, fans and a new **GPL** for the **DCM** are required.

Hardware Requirements

The **DCM** card currently takes up two slots in the **EAGLE** shelf card cage due to the large heat sink on the top of the **DCM** card. Because of this, the **DCM** cannot be provisioned in any arbitrary slot. Because certain slots in the card cage are adjacent to the cage sides, and/or are adjacent to metal supports welded into the card cage, these slots cannot be used to house a **DCM** card.

Also, the **DCM** card requires a substantial amount of power. Due to the way the **EAGLE** fuses power pairs of card slots, the **DCM** should always be provisioned into an odd-numbered card slot. For example, fuse 1A provides power to both slots 1101 and 1102. The combined current draw for both of these slots must not exceed 3A or the fuse may blow. Inserting a **DCM** into slot 1102 when there is another card in 1101 could cause the total current requirements for both of these slots to exceed 3A.

Additionally, the shelf equipped with the **DCM** card must be equipped with fans in order to keep the card from overheating.

Fan Assembly

The fan assembly is provided with the **EOAP** and is also a necessary item for the **DCM**.

Note that the airflow provided by the Fan Assembly is approximately 100 cubic feet per second.

5.101 STPLAN SSEDCEM Capacity Increase (Release 34.0)

Description

This feature allows the user to select either 10 Mbps or 100 Mbps for the data link speed of the Ethernet connection on the Single Slot Enhanced **Database** Communication Module (**SSEDCEM**) **STPLAN** card.

Hardware Requirements

The **VXWSLAN** card is required for 100 Mbps data links.

5.102 STPLAN with Default Router (Release 23.0)

The **STPLAN** application allows the user to selectively copy received messages to a remote host for further processing. The external link consists of an Application Communication Module (**ACM**) equipped with an Ethernet interface using the **TCP/IP** protocol to communicate to an external processing device. Each **ACM** card supports a single destination host. In previous releases, each **ACM** and corresponding host had to be in the same network. This feature allows messages to be sent to a remote host on a different network using a **TCP/IP** router between the **ACM** and the corresponding host. Messages destined for a host in a different network or subnetwork are sent to the default router for routing. Messages destined for a host that is in the same network as the **TCP/IP** data link is not sent to the router but is sent directly to the remote host. The router is not part of the **EAGLE**.

Figure 5-18 shows an example of using a router with the **STPLAN** feature. **ACMs** 1 and 2, with **IP** addresses 193.4.202.50 and 193.4.202.57, need to route their traffic to the remote host at **IP** address 200.11.202.44. The **ACMs** and the remote host are in two different networks, the network **ID** of the **ACMs** is 193.4.202 and the network **ID** of the remote host is 200.11.202. The **EAGLE** can only connect to **TCP/IP** nodes that are in the same network as the **EAGLE**. A **TCP/IP** router is placed in between the **EAGLE** and the remote host. The **TCP/IP** router is located in the same network as the **EAGLE**, with the **IP** address of 193.4.202.87. The messages can now be sent to the remote host through the **TCP/IP** router.

Figure 5-24 STPLAN Router Example

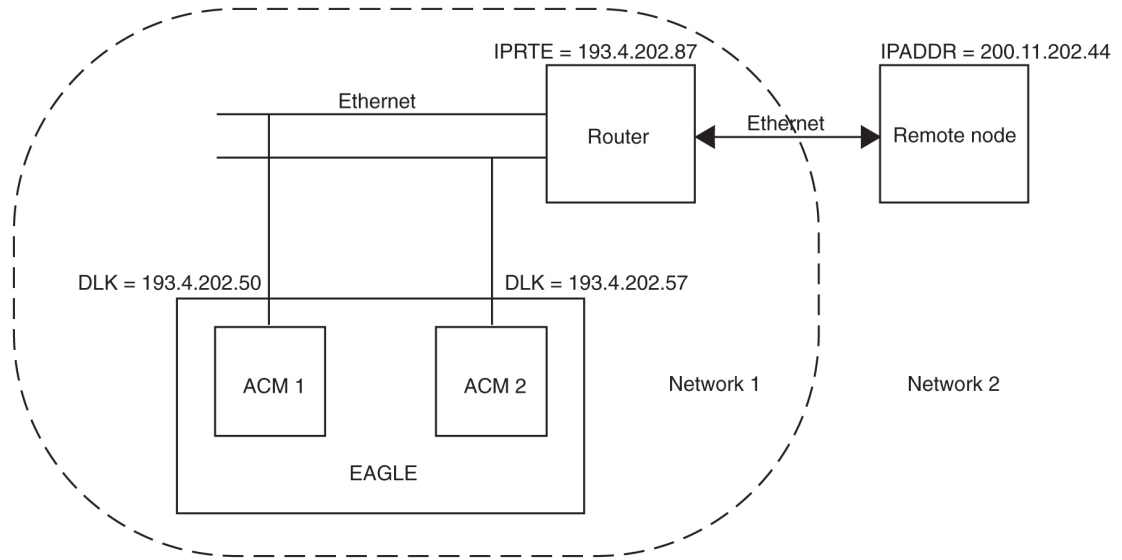

The **EAGLE** requires that a default router be entered when the class and network **ID** of the data link's **IP** address and the host's **IP** address do not match or when subnet routing is used. The **EAGLE** cannot tell whether the user has deployed a large network or is using subnet routing. In a large network, no **TCP/IP** routers are required because all the nodes are directly connected to a single Ethernet network as shown in [Figure 5-19](#).

Figure 5-25 STPLAN in a Large Network

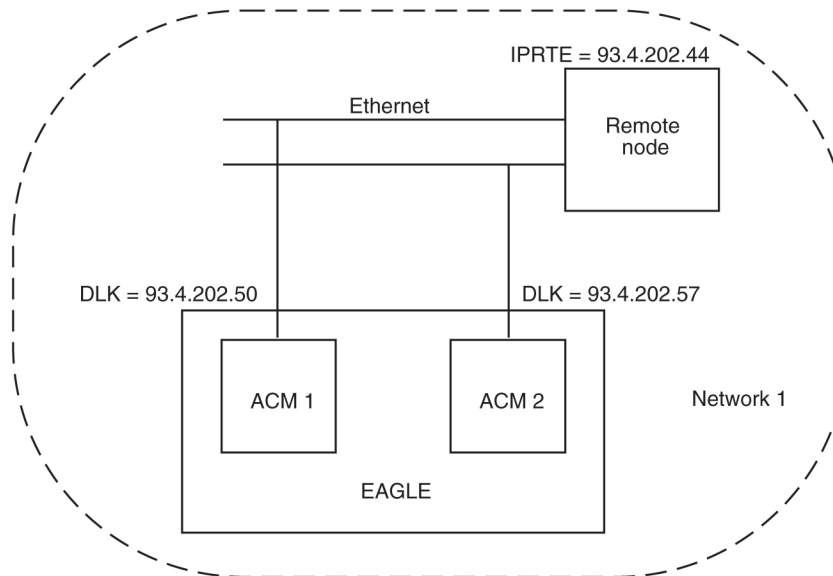

If a user is using subnet routing and therefore multiple Ethernet networks, **TCP/IP** routers are required and must be configured in the **EAGLE** as shown in [Figure 5-20](#).

Figure 5-26 STPLAN Network with Subnet Routing

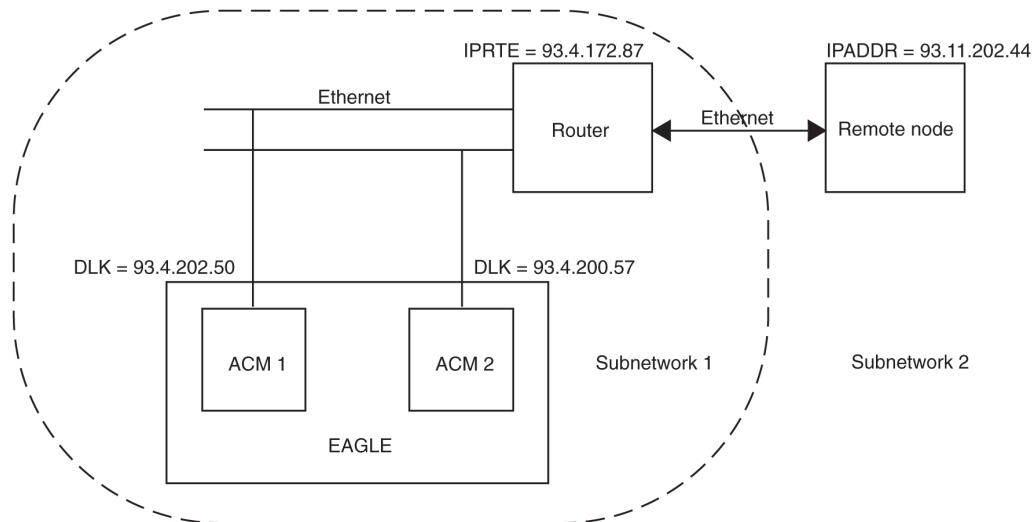

The **EAGLE** cannot distinguish between a large network and the use of subnet routing, and cannot detect the omission of a **TCP/IP** router. For example, the **IP** addresses of the **TCP/IP** data links and the remote node are the same in Figures 5-19 and 5-20. In Figure 5-19, the remote node is in the same network as the **TCP/IP** data links, so no **TCP/IP** router is needed. In Figure 5-20, the user is using subnet routing. The remote node is in one subnetwork, and the **TCP/IP** data links are in another subnetwork. Even though the network portion of the **IP** addresses of the **TCP/IP** data links and the remote node are the same (93, a Class A **IP** address), a **TCP/IP** router is required because the user is using subnet routing.

If, when the user is configuring **STPLAN** according to the network in Figure 5-20, the **TCP/IP** router is not configured with the `ent-ip-node` command, the **EAGLE** will not detect that the **TCP/IP** router has been omitted. No warnings will be given that the **TCP/IP** router has been omitted. The data link will be unable to function since it will not be able to connect to the **TCP/IP** node. The **EAGLE** sees the remote node as a **TCP/IP** node in the same network as the **TCP/IP** data links, because of the class of the **IP** addresses, and does not require the user to specify the `iprte` parameter of the `ent-ip-node` command.

5.103 SUA DAUD with SSN Support (Release 37.0)

Description

The SUA DAUD with SSN Support feature allows the EAGLE 5 ISS to update SCCP cards on the status of remote subsystems connected to the EAGLE 5 ISS and to use destination state audit (DAUD) messages that contain the `ssn` parameter to query the status of any subsystem.

The SUA DAUD with SSN Support feature enables to the EAGLE 5 ISS to perform the following functions:

- Update the SCCP cards with the status of remote subsystems to indicate whether the subsystems are allowed or prohibited

- Determine the status of any subsystem using destination audit (DAUD) messages that contain the **ssn** parameter.

When a node for a remote subsystem becomes available or unavailable, then the SUA DAUD with SSN Support feature allows the MAP table, maintained on the EAGLE 5 ISS SCCP cards, to be updated with the new status.

When a DAUD message containing an ssn parameter is sent over an SUA association to the EAGLE 5 ISS, Gateway Screening is performed by a card that contains the SS7IPGW, IPGWI, or IPGHC GPLs. The message is then sent to the SCCP card to query the availability status of the subsystem. The EAGLE 5 ISS sends one of the following responses based on the subsystem status:

- Status is available—Destination Available (DAVA) message
- Status is unavailable—Destination Unavailable (DUNA) message
- Status cannot be determined—Subsystem Status Unknown error message

Feature Control Requirements

None.

Hardware Requirements

None.

Limitations

The SUA DAUD with SSN Support feature has the following limitations:

- DAUD messages that contain the SSN parameter are not subjected to the Gateway Screening service.
- Subsystem status updates are implemented only when the route key is full SCCP (DPC-SI[3]-SSN). If a subsystem is present on a remote ASP connected by an AS that has only DPC or DPC-SI route key, then the IPGWx code does not send updates on the status for the remote subsystem to the SCCP management module.

5.104 Support >25 SCCP cards with EPAP T1200 application server (Release 42.0)

The Support >25 SCCP cards with EPAP T1200 application server allows up to 32 SCCP cards to be supported when any EPAP-based feature is turned on and an EPAP T1200 application server is used. This feature also increases the system **SCCP** transactions per second (TPS) to (Maximum card TPS * 32 cards).

This functionality impacts the **TPS** quantities implemented by the E5-SM4G Throughput Capacity feature. [Table 5-21](#) shows the revised TPS capacities for each E5-SM4G Throughput Capacity quantity.

Table 5-21 TPS Capacities

Feature Quantity Part Number	Maximum TPS Capacity per E5-SM4G Card	Maximum System TPS Capacity*
893-0191-01	3125	75,000 TPS with one or more EPAP-related features and 24+1 cards
		96,875 TPS with one or more EPAP-related features enabled and 32 cards
	5000	150,000 TPS with no EPAP-related or ELAP-related feature traffic and 31+1 cards
		120,000 TPS with G-Flex and the ANSIGFLEX STP option and 24+1 cards
		155,000 TPS with G-Flex and the ANSIGFLEX STP option and 31+1 cards (EPAP running on T1200 AS)
893-0191-02	6800	40,000 TPS with ELAP and 8+1 cards
		85,000 TPS with ELAP and 17+1 cards
		210,800 TPS with no ELAP-related or without EPAP-related feature traffic and 31 + 1 cards
		163,200 TPS with one or more EPAP-related features and 24+1 cards
		54,400 TPS with ELAP and 8+1 cards
		115,600 TPS with ELAP and 17+1 cards

*32 cards implies an N+1 configuration, so 31 cards are used for calculating actual TPS capacity.

5.104.1 Hardware Requirements

- All cards must be DSM or E5-SM4G cards.
- A T1200 Application Server is required.
- 4 Telco GigE switches are required for the EAGLE 5 ISS and EPAP inter-connection.

5.105 Support 12 Million Ported Numbers (Releases 24.0, 25.0)

This feature is not supported in initial shipments of Release **EAGLE** 25.0. Tekelec will issue a notice when the feature becomes available.

The Support for 12 Million Ported Numbers feature allows the **EAGLE** to contain and process 12 million ported telephone numbers for the local number portability (**LNP**) application. Before Release 25.0, the **EAGLE** could contain only four million ported telephone numbers.

Note:

For Release 24.0, the **EAGLE** supports only 4 million ported telephone numbers.

For the **EAGLE** database to contain up to 12 million ported telephone numbers, six `lnp_4digit` database objects must be in the database. Each `lnp_4digit` database object consists of two tables, one in the current partition and one in the backup partition of the database. The **EAGLE** database currently contains one `lnp_4digit` database object containing up to two million ported telephone numbers. This database object contains the database tables named `lnp_4dig.tbl` and `lnp_4dig.bkp`.

Refer to the **Database Administration Manual - LNP** and the **LNPDatabase Synchronization Manual** for the current details on this feature.

5.106 Support 22 Non-Provisionable EPAP Nodes (EPAP 13.0)

EPAP supports two provisionable EPAP nodes feeding up to 22 non-provisionable EPAP nodes. Each EPAP node contains two EPAP servers, or a total of 48 EPAP servers. The provisioning server should be a T1200 AS, and the non-provisioning EPAPs can be either T1000 or T1200 ASs

Hardware Requirements

A T1200 Application Server

5.107 Support Changing the Linkset Name (Release 28.0)

With this feature, the **EAGLE** supports changing the linkset name via an **EAGLE** terminal or **SEAS**, without having to delete or change any other data associated with the linkset (e.g. `ent-ls` command parameters, links, routes).

The ability to change the linkset name via **SEAS** is supported via the following methods:

- A supplier-specific parameter for the `chg-ls` and `chg-gtwyls` commands
- Flow-through

All **EAGLE** data that referenced the old linkset name will now reference the new linkset name, except for *old* entries in the security log.

5.108 Support CHG-GTT to change the GTA (Release 35.0)

Description

The Support CHG-GTT to change the GTA feature enhances the `chg-gtt` and `chg-gta` commands to a GTT or EGTT range to be extended or reduced with a single command instead of deleting the original range and entering a new range.

For example, extending the range `5551234-5554567` to `5551234-5559999` can be performed in one command, using the `chg-gtt` or `chg-gta` command.

Likewise, reducing the range `5551234-5552999` to `5551234-5554567` can be performed in one command, using the `chg-gtt` or `chg-gta` command.

Hardware Requirements

The Support CHG-GTT to change the GTA feature has no hardware requirements.

Limitations

The Support CHG-GTT to Change the GTA feature has the following limitations:

- Range consolidation or 'self-healing' ranges, (`5551234-5554567` and `5554668-5559999`, for example) remain two entries. A user can delete `5554668-5559999`, then enter `chg-gtt` for `5551234-5554567` to be changed to `5551234-5559999`, but this action requires two commands.
- Overlapping ranges are rejected, (`5551234-5554567` and `5557000-5559999`, for example). The user cannot use `chg-gta` on the first entry such that the EGTA is greater than `5556999`, because it would create overlapping GTT entries. The same applies for single GTT entries.

5.109 Support CRP check for SRI_SM using TCAP digits (Release 43.0)

The Support CRP check for SRI_SM using TCAP digits feature allows SCCP or TCAP MSISDN digits of SRI_SM messages to be used as the Directory or Dialed Number (DN) for MNP Circular Route Prevention (MNPCRP) processing performed by the MT-Based GSM SMS NP feature.

If the TCAP MSISDN is used as the DN, a Home Routing Number (RN) match is found in the incoming TCAP MSISDN digits, and the SRI_SM message is to be relayed, then the RN digits from the TCAP MSISDN are stripped before relaying the message to the Home Location Register (HLR).

5.109.1 Feature Control Requirements

The MT-Based GSM SMS NP feature (Part Number 893-0200-01) must be enabled before the Support CRP check for SRI_SM using TCAP digits functionality can be provisioned.

5.110 Support FastCopy on IPGW (Release 42.0)

The Support FastCopy on IPGW feature provides support for monitoring M3UA and SUA traffic on E5-ENET cards running the IPGHC GPL using Fast Copy-based or **STC** monitoring.

5.110.1 Hardware Requirements

The Fast Copy feature requires E5-ENET cards.

If Fast Copy monitoring is active, and an E5-ENET card is replaced by a DCM card, then the DCM card will perform STC-based monitoring, and any remaining E5-ENET cards will perform Fast Copy monitoring.

5.111 Support for 16 GTT Lengths in VGTT (Release 41.0)

The existing **VGTT** feature is enhanced to allow provisioning of 16 different GTT digit string lengths per translation type in a GTT set.

5.111.1 Feature Control Requirements

Feature control requirements for the Support for 16 GTT Lengths in VGTT feature include:

- The VGTT feature must be turned on before the Support for 16 GTT Lengths in VGTT feature can be enabled.
- A FAK for part number 893-0248-01
- A temporary FAK cannot be used to enable the feature.
- The feature cannot be turned off after it is turned on.

5.111.2 Hardware Requirements

The Support for 16 GTT Lengths in VGTT feature requires an E5-SM4G or higher card.

5.112 Support for 32 Prepaid SMS Intercept Platforms (Release 37.0)

Description

The Support for 32 Prepaid SMS Intercept Platforms feature enhances the capability of the EAGLE 5 ISS to support routing from 3 to a maximum of 32 Intercept Platforms and increases the number of Prepaid Portability Types by the EPAP to 32 to specifically identify a subscriber with an SCP.

The Support for 32 Prepaid SMS Intercept Platforms feature increases the number of Prepaid Portability Type (PPT) subscribers and Intelligent Network (IN) SCP Point Code + Routing Indicator (PC + RI) translations that can be supported by the Prepaid SMS Intercept Phase 1 (PPSMS) feature to 32. Each translation corresponds to an IN platform and can be either ITU-N, ITU-I or a combination of the two.

Any subscriber that is not one of the 32 PPTs is considered to be a postpaid/contract subscriber.

The Support for 32 Prepaid SMS Intercept Platforms feature allows any Mobile Station Integrated Services Digital Number (MSISDN) in the RTDB to be associated with any of the 32 PPTs. Each PPT can then be associated with any of the IN platforms.

Loadsharing can be performed across 8 of the IN platforms, using the MAP and MRN tables. If the Transaction-Based Weighted GTT feature is turned on, then loadsharing can be performed across all 32 platforms.

If the Flexible GTT Loadsharing (FGTTLS) feature is turned on, then lookup in the MAP or MRN table is performed using the set ID (SETID) obtained from the PPSOPTS table. If the FGTTLS feature is turned off, then lookup is performed on only the default MAP or MRN set.



Note:

The Support for 32 Prepaid SMS Intercept Platforms feature removes the dependency of the PPSMS feature on the G-Port feature. PPSMS can now be enabled without enabling G-Port.

Feature Control Requirements

The Support for 32 Prepaid SMS Intercept Platforms feature is enabled when the PPSMS feature is enabled. The G-Port feature does not have to be enabled before enabling the PPSMS feature.

Hardware Requirements

None.

Limitations

None.

5.113 Support for 32 Prepaid SMS Intercepts (EPAP 9.0)

Description

The Support for 32 Prepaid SMS Intercepts feature increases the number of supported Prepaid SMS Intercepts from 8 to 32.

Supported GTT (Global Title Translation) destinations have been expanded to 32, and IN SCP (Intelligent Network Service Control Point) platforms and EPAP portability types have been expanded to 32 from 8.

The PPSMS (Pre-paid Short Message Service) Phase 1 feature uses a G-Port DN portability type (PT) field to identify the types of prepaid subscribers whose originated short messages (as part of SMS) need to be intercepted and forwarded to a corresponding intelligent network platform for verification.

In EPAP 9.0, the PPSMS Phase 2 feature expands the PT range to support 32 types of prepaid subscribers.

For PPSMS, the PT parameter on the `ent_sub`, `upd_sub`, and `rtrv_sub` commands identifies a DN as one of 32 types needing PPSMS intercept.

Hardware Requirements

None.

Limitations

None.

5.114 Support for 2000 ITU Links per Node (Release 35.1)

Description

The Support for 2000 **ITU** Links per Node feature increases the total capacity of an **EAGLE 5 ISS** node from 1500 to 2000 links.



Note:

Although the Support for 2000 **ITU** Links per Node feature increases the total capacity of the node, the increase applies to **ITU** links only. The maximum number of **ANSI** links that can be supported by the node remains 1500.

This feature requires a **Feature Access Key**.

Hardware Requirements

The Support for 2000 **ITU** Links per Node feature has the following hardware requirements:

- **HIPR** cards installed on every provisioned shelf in the system
- The following link/card counts are supported:
 - Maximum 115 **LIM-ATM** cards
 - Maximum 100 **IPLIM** cards
 - Maximum 64 **IPGWx** cards
 - Maximum 64 **SE-HSL** links

Limitations

The Support for 2000 **ITU** Links per Node feature has the following limitations:

- This feature is supported for **ITU** links only. **STP-LAN** and **ANSI** links are not supported.
- The following cards are not supported for **ITU** configurations above 1500 links/node: **MPL**, **MPL-T**, **LIM-ATM**.
- The following cards are not supported for any configuration above 1500 links/node: **LIM-DS0**, **LIM-OCU**, **LIM-V.35**, **LIM-AINF**, **LIM-ILA**, **LIM-EILA**

5.115 Support for 2800 Provisioned Links Per Node (Release 41.1)

The Support for 2800 Provisioned Links per Node feature extends the Large System # Links feature to allow up to 2800 SS7 links to be provisioned on an EAGLE 5 ISS node.

Current limits on the maximum number of cards and links for each application continue to be supported as shown in [Table 5-22](#).

Table 5-22 Links and Cards Limits per Application

Application/GPL	Maximum Number of Cards	Maximum Number of Links/ Card
IPSG	100 (E5-ENET)	32
IPLIM	100 (E5-ENET)	16
IPGW	125 (E5-ENET)	1
SS7 (ANSI/ITU)	250 (E5-E1T1)	32 (E1/T1)
	125 (HC-MIM)	64 (E1/T1)
	64 (HC-MIM)	2 (SE-HSL)
ATM	90 (E5-ATM)	2
VSCCP	32	N/A
GLS	8	N/A
STPLAN	32	N/A

5.115.1 Feature Control Requirements

- The Large System # Links feature (Part Number 893-0059-11) must be enabled
- If any card other than those provided in the [Hardware Requirements](#) section is present in the system, then the feature cannot be enabled.
- This Large System # Links feature is an enable-only feature. Once enabled, the default status of the feature is ON.
- The feature cannot be turned off after it is enabled.
- A temporary FAK cannot be used to enable the feature.

5.115.2 Hardware Requirements

- The following cards are supported with 2800 links on an EAGLE node:
 - HC-MIM
 - E5 E1/T1
 - E5-ATM
 - E5-SM4G
 - E5-ENET
 - E5-OAM

- HIPR
- SLAN (SSEDCM and E5-SLAN)
- STC (SSEDCM and E5-STC)
- MCPM
- IPSM/E5-IPSM
- TSM/E5-TSM (for GLS)

If any other card is installed after the feature is enabled, then the card is auto-inhibited.

- The active and standby OAM cards must be based on E5-OAM.

5.115.3 Limitations

Certain card types and link types combinations prevents achievements of 2800 links capacity. Refer to [Table 5-22](#) for the current limits on card and link types.

5.116 Support for IP7 8.0 Gateway Features (EAGLE Release 30.0/IP7 Secure Gateway Release 8.0)

Description

EAGLE Release 30.0 supports the feature content of **IP⁷ Secure Gateway Release 8.0** (i.e. **SCTP Checksum** Update, **M3UA** Protocol Enhancements), as well as all **IP⁷** content supported by **EAGLE** Release 29.x.

5.117 Support for IPSG M3UA and SCTP Graceful Shutdown (Release 41.0)

The Support for IPSG M3UA and SCTP Graceful Shutdown feature consists of two aspects:

- **M3UA Graceful Shutdown**
The **ipsg** application is updated to increase the shutdown timer to 2 seconds, which allows the ASP to deplete all the messages from its queue before the ASP is brought down. The M3UA software is also enhanced to progress the shutdown when a designated response is received from a peer.
- **SCTP Graceful Shutdown**
SCTP functionality of the **ipsg** application is updated to allow manual initiation of graceful shutdown for an M3UA association.

5.117.1 Hardware Requirements

M3UA and SCTP shutdown is performed on only E5-ENET cards running the **ipsg** application.

5.118 Support for LSMS Audit Enhancements (Release 26.1)

LSMS users need a method of auditing locally provisioned data as well as data that is sent from the **NPAC** to the **LSMS** and subsequently sent to the **EAGLE**. Currently the following data cannot be audited from the **LSMS** and raises concerns about database consistencies.

- Default **GTT**
- Override **GTT**
- **NPA-NXX** Split Data

This feature provides support for the **LSMS** audit of default **GTT**, override **GTT**, and **NPA-NXX** split data residing at the **EAGLE**. The **LSMS** audits the data, which is locally provisioned at the **LSMS**, against the data at the **EAGLE LNP** databases. **EAGLE** support allows **LSMS** retrieval of the data from the **EAGLE** database. (The **LSMS** will offer a mechanism to reconcile any discrepancies detected.)

In previous releases, even though the **EAGLE** allows the **LSMS** to provision Default **GTT**, Override **GTT**, or service provider database entries, it provided no mechanism to allow the **LSMS** to retrieve the **DB** entities that it has provisioned. This hampered the **LSMS** from determining exactly what was present in the **EAGLE LNP DB** for these entity types: the **LSMS** could add and delete these entity types, but could not retrieve them.

This feature rectifies this situation by adding the following new commands to facilitate additional auditing capabilities at the **LSMS**:

- `vfy-lnp-6ddt`
- `vfy-lnp-lrnovr`
- `vfy-split-npa`

These commands are used similarly to the existing `vfy-lnp-10dt` command:

- They are sent by the **LSMS** to the **EAGLE** via the **OAP** across the **OAP ↔ EAGLE** serial interface (also known as the "2 TN/sec channel," or the "slow channel").
- They support retrieval of a single **DB** entity (see section 3.1.2 on page 13)
- The command response is returned to the **LSMS** via the **OAP**, and is formatted similarly to the `vfy-lnp-10dt` output (i.e. machine-readable).

See [Component Interaction Scenario](#) more information on these commands.

Auditing the **EAGLE** via High-Speed Audit

EAGLE Release 25.0 introduced a new feature, "Enhanced Bulk Download & Audit," which allows the **LSMS** to audit the subscription component of the **EAGLE LNP DB** at a very high speed, using an ethernet connection that directly connects the **LSMS** and **EAGLE**. This audit proceeds as follows:

1. **LSMS** tells **EAGLE**, via the ethernet connection, what range of subscriptions are to be returned. A starting and ending **NPANXX** is specified, and all subscriptions provisioned within that range are returned.

2. The **BLM** card on the **EAGLE** (which has a complete copy of the **EAGLE LNP DB** resident in its **RAM** memory) retrieves each subscription in the start/end range from its database, computes a checksum for the subscription, and returns the subscription's **TN** (i.e. its "key") and computed checksum to the **LSMS**, again using the ethernet connection
3. **LSMS** computes a checksum for each of the requested subscriptions, and then compares them against the checksum returned by the **EAGLE**:
 - Matching checksums indicate that the subscription information on the **EAGLE** exactly matches the information on the **LSMS**.
 - Mismatching checksums indicate that the **EAGLE** has the subscription in its database, but that one or more attributes of the subscription (e.g. **LRN**) are different. The **LSMS** should update the subscription information in the **EAGLE** to bring the **EAGLE** into sync with the **LSMS**.
 - If the **EAGLE** does not return a **TN**/checksum pair for a subscription that the **LSMS** has, this indicates that the **EAGLE** is missing the subscription. The **LSMS** should add the subscription to the **EAGLE** database.
 - If the **EAGLE** returns a **TN**/checksum pair for a subscription that the **LSMS** does not have in its database, this indicates that the **EAGLE** still has a subscription that should have been deleted. The **LSMS** should delete the wayward subscription from the **EAGLE**'s database.

The Support **LSMS** Audit Enhancements feature also allows auditing, via the high-speed ethernet link, of the **EAGLE**'s database components:

- default **GTT** (**NPANXX**)
- override **GTT** (**LRN**)
- **NPA** split

The auditing of the default **GTT**, override **GTT**, and **NPA** split database entities takes place in a manner similar to that described above for subscriptions, i.e. **LSMS** will request checksums for a range of entities, and the **EAGLE** returns the information (**DB** entity key/checksum) via the high-speed ethernet connection.

Component Interaction Scenario

As mentioned, the new auditing and provisioning capabilities that these features provide can take place over either the **OAP** serial channel, or over the high-speed **IP** channel. The following scenarios describe the sequence of events that occur over each.

New Audit Capabilities via OAP Serial Channel

In the following list, the item numbers correspond to the *circled* numbers in [Figure 5-27](#).

1. The user at the **LSMS** terminal decides to audit something via the serial **OAP** connection: override **GTT**, default **GTT**, **Split NPA**, subscriptions, etc. The user enters auditing parameters (e.g. start/end range, etc.) at **LSMS GUI** screen.
2. The **LSMS** sends a request to the **OAP** requesting the first **DB** entity to be retrieved for audit. The **OAP** converts this request into a "**SEAS-like**" command (e.g., `vfy-1np-6ddt`).
3. A **SEAS-like** retrieval command is forwarded to the **EAGLE**.
4. The **EAGLE** retrieves the requested **DB** entity from the active **OAM** fixed disk and formats the data into a response using "**SEAS-like**" syntax.
5. A "**SEAS-like**" response is sent to the **OAP** in **ASCII** format

6. The **OAP** converts and transmits the **ASCII** response into a format suitable for the **LSMS**.
7. The **LSMS** compares the **EAGLE DB** entity against its own database, and displays discrepancy information to the user at the **LSMS** console.

This retrieve/compare/display cycle repeats until all **DB** entities have been audited, or until the **LSMS** user cancels the audit.

Should the **LSMS** user elect to reconcile the problem(s) detected by the audit, the reconcile commands (e.g. `upd-split-npa`, etc) are sent to the **EAGLE** using the same **OAP** serial connection. If the **EAGLE** database was severely out of sync, the **LSMS** operator can elect to reconcile the problem using the Enhanced Bulk Download feature.

Note that the **LSMS** operator has a choice as to how any **DB** updates are sent to the **EAGLE**: the **LSMS** operator can choose to send them either via the serial connection (makes sense if the number of commands to be sent is small), or via the high-speed **IP** connection (makes sense if the number of commands is very large).

Figure 5-27 LSMS Auditing/Split Provisioning: Sequence of Events

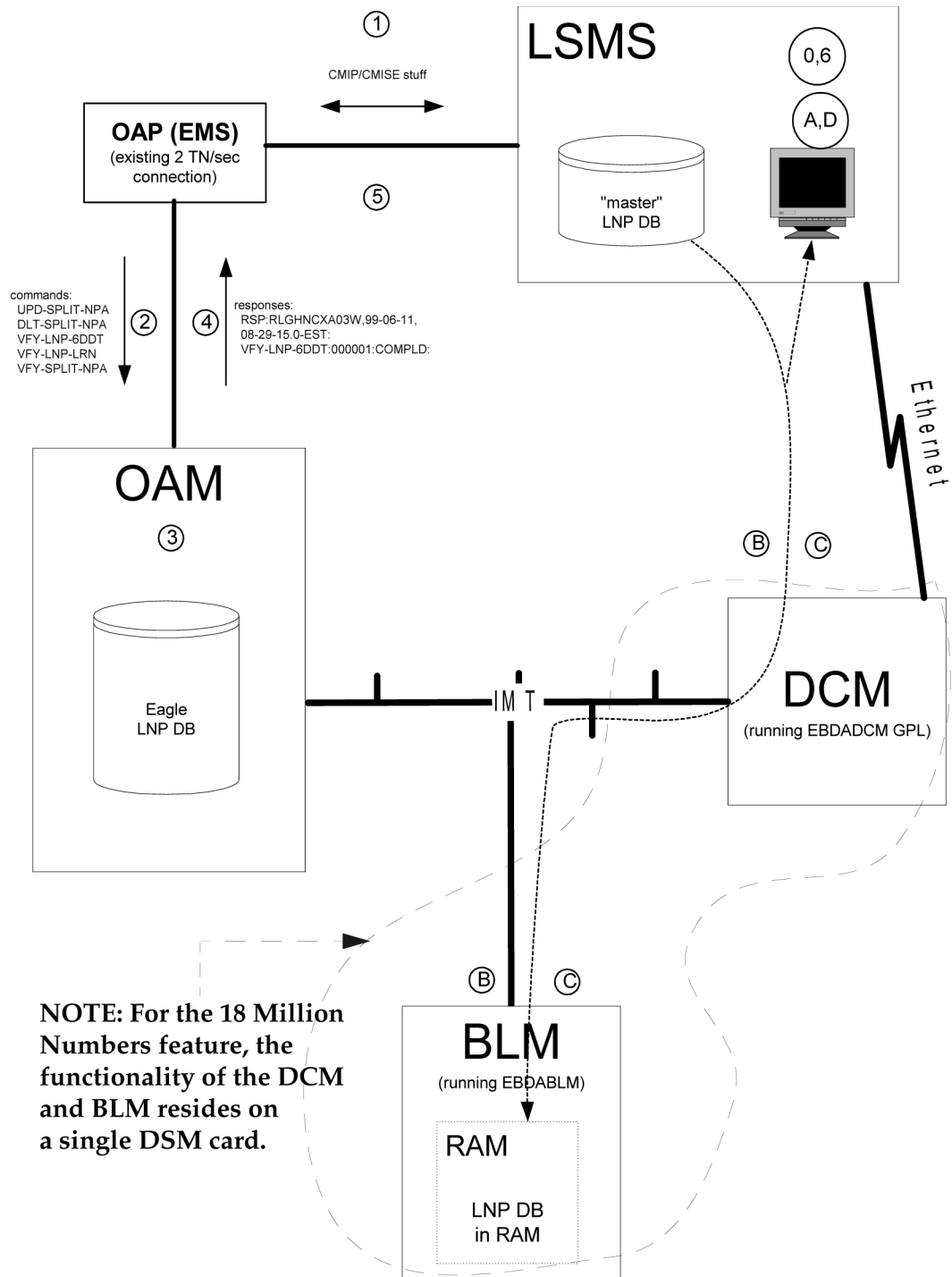

New Audit Capabilities via High-Speed IP Channel

The items in the following lettered list correspond to the *circled* letters in [Figure 5-27](#):

1. The user at the **LSMS** terminal decides to audit something via the high-speed **LSMS ↔ EAGLE IP** connection: override **GTT**, default **GTT**, **Split NPA**, subscriptions, etc. The user enters auditing parameters (e.g. start/end range, etc.) at **LSMS GUI** screen.

2. The **LSMS** sends a request to **EAGLE's DCM** card (running **EBDADCM GPL**) via the **IP** connection, which is forwarded across **IMT** to **EAGLE's BLM** card (running **EBDABLM GPL**).
3. The **BLM** card retrieves requested **DB** entities (e.g. Override **GTT** entries), generates a **CRC-32** checksum for each entity, and returns the entity key (e.g. for Override **GTT** entity, the key would be the **LRN**) and its corresponding checksum to the **DCM**, which is then forwarded to the **LSMS** via the high-speed **IP** connection.
4. The **LSMS** retrieves the corresponding **DB** entity from its own database, computes the **CRC-32** checksum, then compares the checksum against what the **EAGLE** has provided. Any mismatching of the checksums indicates that what the **EAGLE** has for this entity is different than what the **LSMS** has. Furthermore, the **DB** entity keys that are returned from the **EAGLE** allow the **LSMS** to detect superfluous entries in, and entries that are missing from, the **EAGLE LNP DB**. All discrepancies are displayed to the **LSMS** operator.

This retrieve/checksum/compare/display cycle repeats until all **DB** entities have been audited, or until the **LSMS** user cancels the audit.

Should the **LSMS** user elect to reconcile the problem(s) detected by the audit, the reconcile commands (e.g. `upd-split-npa`, etc.) would likely be sent to the **EAGLE** using the **OAP** serial connection. If the **EAGLE** database was severely out of sync, the **LSMS** operator could elect to reconcile the problem using the Enhanced Bulk Download feature.

Limitations

The new verify (`vfy-xxxxxx`) commands mentioned above do not support the retrieval of ranges of database entries. Instead, each command accepts the key of a single database entity to be retrieved. The command output shows the details of the single database entity that was specified, assuming that the entity exists, or error information (if it doesn't).

5.119 Support for LSMS Split Provisioning (Release 26.1)

NPA-NXX splits currently are provisioned locally at the **LSMS** and at the **EAGLE**. This is not the optimum method of provisioning **LNP** data, as the **LSMS** can service multiple **EAGLEs**, making coordination of entering split data cumbersome.

This feature allows **NPA-NXX** Split data to be provisioned at the **LSMS** and forwarded to the **EAGLE**, instead of being provisioned at the **EAGLE** separately. This feature supports a single point **NPA** Split administration from the **LSMS**.

Over OAP Serial Channel

This feature implements a set of commands that allow the **LSMS** to provision and query **NPA** split information at the **EAGLE**, using the connection that exists between the **EAGLE** ↔ **LSMS** provided by the **OAP**. These new commands are:

- `upd-split-npa`
- `dlt-split-npa`
- `vfy-split-npa`

See the *Commands Manual* for more information on these commands.

Via Enhanced Bulk Download

This feature supports downloading of **NPA** split information to the **EAGLE** as part of a high-speed bulk download. This existing high-speed bulk download facility has been expanded to allow **NPA** split information to be downloaded.

Limitations

The new verify (`vfy-xxxxxx`) command mentioned above does not support the retrieval of ranges of database entries. Instead, each command accepts the key of a single database entity to be retrieved. The command output shows the details of the single database entity that was specified, assuming that the entity exists, or error information (if it doesn't).

5.120 Support for Matching Self-ID Rule in SEAS CHG-SID (Release 22.0)

In previous releases the **SEAS ASGN-SID** and **CHG-SID** command functions could change the self **ID** point code and **CLLI** of the **EAGLE** if either **SEAS** command were entered. From the **SEAS** interface, only the **ASGN-SID** command function can change the point code and **CLLI** of the self **ID**. The **CHG-SID** command function is not supposed to change the point code or **CLLI** of the **EAGLE**, but those parameters are used to verify whether they match the current point code and **CLLI** of the **EAGLE**.

This feature adds a rule to the **SEAS CHG-SID** command function on the **EAGLE** that requires that the specified point code and **CLLI** to match the current self **ID** point code and **CLLI** of the **EAGLE**. If they do not match the current values, the **CHG-SID** command attempt is rejected.

This gives customers using the **SEAS** interface protection against accidental changing of the **EAGLE**'s self **ID**. This feature does change the functions of the **SEAS ASGN-SID** and **EAGLE chg-sid** commands.

5.121 Support for MTP Status Functions (IP⁷ Release 2.0)

This feature, available only on **DCM** cards that support the **ss7ipgw** application, allows the **Message Transfer Part (MTP)** status of point codes in the **SS7** networks to be made available to **IP**-connected media gateway controllers (**MGCs**) and **IP-SCPs**. This feature is similar to the **MTP3** network management procedures used in an **SS7** network.

This feature enables an **IP** device to:

- Divert traffic from an **SG** that is not able to access a point code that the mated **SG** can access
- Audit point code status
- Build up routing tables before sending traffic
- Be warned about **SS7** network congestion
- Abate congestion
- Obtain **SS7** User Part Unavailability status

5.122 Support for Provisioning Multiple EPAPs (Release 29.0)

Currently, it is only possible to provision a single mated pair of **MPS** nodes, where each **MPS** node contains one **EPAP A** and one **EPAP B**. **EPAP A** contains a **PDB** and an **RTDB**. **EPAP B** contains only an **RTDB**. For customers who need to deploy more than one pair of **MPSs**, this requires them to provision each pair separately.

Many customers desire the ability to add more **MPSs** without having to change their provisioning system, or provision from multiple sources.

This feature is transparent to the **PDBI** clients. Each client can provision data in the same manner, no matter if it is provisioning a single **MPS** pair, or multiple **MPS** pairs.

With **EPAP 3.0**, customers may choose to add **EAGLEs** to their network without changing the way that they provision data. **EPAP** Software updates the Real-time databases at the additional sites. The two **MPSs** that contain the **PDB** are called "provisionable" because these are the sites to which the customer provisioning application may connect. The additional **MPSs** are called "non-provisionable."

Newly added non-provisionable **MPSs** will use the Selective Homing of **EPAP RTDBs** feature to specify the **PDB(s)** from which to receive updates.

Hardware Requirements

The **MPS** platform is required to support the ability to install both provisionable and non-provisionable **EPAP MPSs**.

Enhancements to the User Interface

With the addition of Support for Provisioning multiple **EPAP RTDBs**, references to the "Local" and "Remote" **PDB** may no longer have meaning. These references will be changed throughout the text **UI** and **GUI** to specify the **IP** address of the **PDB** being identified.

Upgrade Considerations

This feature does not impact the **EPAP 1.x/2.x** to 3.0 upgrade. New **EAGLEs** may not be included for provisioning until all affected sites have been upgraded to **EPAP 3.0**. Interaction with **EAGLE** is not affected by this feature.

5.123 Support for SCCP XUDT/XUDTS Messsages, In-Sequence Delivery of Class 1 SCCP UDT/XUDT Messages (Release 31.6)

Description

With the introduction of various new applications in the wireless industry, the size of application data on top of **SCCP** layer has increased to a point where it does not fit in a single **MTP** message. This has led to the requirement of segmentation and reassembly of the **SS7** messages - both at **SCCP** level and at higher application levels (like **TCAP**). These messages are carried over **SCCP** class 0 protocol and **SCCP**

class 1 protocol. Class 1 is used when the sequence of the segments of the message and number of message within the same transaction or dialogue needs to be guaranteed at the arriving node.

The **EAGLE** distributed architecture and internal method of load sharing across **SCCP** processing cards means that one message of a sequence could arrive at one **SCCP** card for processing, while another message in the same sequence could arrive at a different **SCCP** card for processing. Depending upon the current loads and buffer levels in the two **SCCP** cards, it is possible that the second message may complete **SCCP** processing and arrive at the outgoing link ahead of the first message. Thus, the second message will arrive at the destination before the first, and the end node will be unable to process the sequence.

The In-sequence Delivery of **SCCP** Messages feature addresses the in-sequence delivery requirement of **SCCP** protocol class 1 message.

The Support of **SCCP** Extended User Data (**XUDT**)/Extended User Data Service (**XUDTS**) messages feature addresses the processing of **EAGLE** destined **XUDT/XUDTS** messages and in-sequence delivery requirement of **SCCPXUDT/XUDTS** protocol class 1 messages.

Long User Data (**LUDT**)/Long User Data Service (**LUDTS**) messages along with other non-**UDT/XUDTSSCCP** messages will not be supported by **SCCP**. **UIM 1023** is generated on the incoming **LIM** card when **LUDT/LUDTS** messages is received and is destined to **EAGLE**. **MTP** routed **LUDT/LUDTS** messages will continue to be supported by **EAGLE**. However, **GWS**, **TT** mapping and Network Security features will not support **LUDT/LUDTS** messages.

EAGLE support is provided for the following features and functions when processing **XUDT/XUDTS** messages:

- **GTT, EGTT, VGTT**
- All supported link types, including **E1/T1MIM**, **E1-ATM HSL**, **IPLIMx**, and **IPGWx**
- Multiple and duplicate point codes
- **SLAN** and Sentinel Copy
- **G-Flex**
- **LNP** services for Class 1 **UDT** messages
- **INMPR** services (but not **INPQ**)
- **G-Port**, **G-Port** Message Relay, and **IS-41** to **GSM** Migration - **XUDT/XUDTS** messages are supported as long as the **G-PortGSNSRI** or **PPSMS** query or **IS-41** Loc Req messages are not segmented. If a query is segmented, it will be treated as a **G-Port** non-**SRI** or **IS-41** non-Loc **Req** message and message relay will be performed using the **SCCPCDPA** portion of the message.

The In-sequence delivery of **SCCP** messages feature addresses the in-sequence delivery requirement of **SCCP** protocol class 1 message.

The Support of **SCCPXUDT/XUDTS** messages feature addresses the processing of **EAGLE** destined **XUDT/XUDTS** messages and in-sequence delivery requirement of **SCCPXUDT/XUDTS** protocol class 1 message.

- Both **ANSI** and **ITU** Class 1 **UDT** and **XUDT/XUDTS** (both Class 0 and Class 1) messages are supported.

Limitations

- The **NP**, **EIR**, **LNP**, **PPSMS**, **MNPSMS** and **MAP** Screening features that use **TCAP** data do not support **XUDT/XUDTS** messages.

- **EAGLE** does not perform re-ordering of **XUDT/XUDTS** Segmented messages.
- **EAGLE** does not perform any conversion of **XUDT/XUDTS** to **UDT** message and vice versa.
- The Weighted **SCP** Load Balancing and **IGTTLS** features do not support load sharing of messages across equal cost destinations for Class 1 **UDT/ XUDT/ XUDTS** messages (when `rands1s` is **OFF** or **CLASS0**)
- **EAGLE** supports **XUDTS** messages as long as the message length is ≤ 272 bytes.

5.124 Support for Secure Gateway Functionality through IP⁷ 7.0 (Release 29.0)

EAGLE Release 29.0 supports the feature content of **IP⁷** Secure Gateway Release 7.0 (i.e. **IP** User Interface: Telnet Support and **FTP** Retrieve and Replace.

5.125 Support for TALI Architecture (IP⁷ Release 4.0)

Each release of the **IP⁷** Secure Gateway is built to the current level of the Transport Adapter Layer Interface (**TALI**) protocol. This release of the **IP⁷** Secure Gateway supports **TALI** Release 3.0.

5.126 Support for the CLLI Parameter for Adding or Changing Linksets (Release 22.0)

In Release 22.0, the **EAGLE** accepts the **FE-CLLI** parameter when adding a linkset, changing a linkset, and displaying linksets on the **SEAS** interface. The **FE-CLLI** of the point code is not stored in the linkset table, but in the destination point code table.

When the **FE-CLLI** is specified while adding a linkset or changing a linkset's attributes from the **SEAS** interface, the **FE-PC** and **FE-CLLI** are compared with entries in the destination point code table of the **EAGLE**. If the specified values match an entry in the destination point code table, the command adding the linkset is accepted. If either value does not match any entries in the destination point code table, the command is rejected. When changing a linkset's attributes from the **SEAS** interface, the **FE-CLLI** value cannot be changed.

The **EAGLE**'s linkset configuration commands, `ent-ls`, `chg-ls`, and `rtrv-ls`, have also been changed to support this feature. The `clli` parameter has been added to the `ent-ls` and `chg-ls` commands. If the value of the `clli` parameter, specified with either the `ent-ls` or `chg-ls` commands, does not match the value of the **CLLI** of the adjacent point code, shown in the destination point code table by the `rtrv-dstn` command, the command is rejected with this error message.

Error Message

```
E2335 Cmd Rej: CLLI is not identical to that of matching Destination
```

The output of the **EAGLE's** `rtrv-ls` command has been changed to support this feature. The following is an example of the output of the `rtrv-ls` command if a **CLLI** has been assigned to the adjacent point code of the linkset.

5.127 Support for the New Linkset Name Parameter for Changing the Attributes of a Route (Release 22.0)

The linkset name parameter (`nlsn`) has been added to the **EAGLE's** `chg-rte` command and to the **SEAS CHG-RTE** command function. This eliminates the requirement on the **EAGLE** to remove an existing linkset and re-enter the linkset with a different linkset name to change the linkset name.

Error Messages

The following error messages displayed on the **EAGLE** terminal have been added to the `chg-rte` command.

- Either the `nlsn`, or `rc` parameters must be specified with the `chg-rte` command. In neither of these parameter are not specified, the command is rejected and this error message is displayed.

E2136 Cmd Rej: At least one optional parameter is required

- The new linkset specified by the `nlsn` parameter cannot be assigned to any existing routes. If the new linkset is assigned to any existing routes, the command is rejected and this message is displayed.

E2355 Cmd Rej: Linkset already assigned to route

- If a new link set name (`nlsn`) is specified in the `chg-rte` command, that link set name must be defined in the linkset table. If the new linkset name is not defined in the linkset table, the command is rejected and this error message is displayed.

E2346 Cmd Rej: Linkset not defined

- If a new link set name (`nlsn`) is specified in the `chg-rte` command, that linkset must contain at least one signaling link. If the new linkset does not contain at least one signaling link, the command is rejected and this error message is displayed.

E2128 Cmd Rej: Linkset assigned to route must have at least one link

- The new linkset specified by the `nlsn` parameter can be assigned to an adjacent point code that is a cluster point code as long as the linkset type of this linkset is either B, C, or

D. If the linkset type of the linkset that is assigned to a cluster point code is either A or E, the command is rejected and this error message is displayed.

```
E2349 Cmd Rej: Link Set Type invalid for Cluster Destination
```

5.128 Support for Up to 41 IPLIMx DCMs (IP7 Release 2.2)

The IP7 Secure Gateway supports up to 41 **DCMs** that run either the `iplim` application or the `iplimi` application. In previous releases, the limit of **DCM** cards supported for the `iplim` application was six.

In addition, the IP7 Secure Gateway can support two **DCMs** that run the `ss7ipgw` application.

5.129 Support G-Flex at 1700 TPS per DSM (ANSI only) (Release 31.6)

This feature allows the **DSM** card to run at 1700 **TPS** when the **G-Flex** feature is turned on in an **ANSI** environment. Only **G-Flex** can be on to achieve the 1700 **TPS** per **DSM**.

This feature provides an **STP** option to allow the **DSM** card to run at 1700 **TPS** when the **G-Flex** feature is turned on in an **ANSI** environment.

Limitations

- **G-Flex** at 1700 **TPS** per **DSM** is supported only when **G-Flex** is the only database feature active and there are no **ITU** service selectors provisioned.

5.130 Support IPSPG Link Capacity Sharing (Release 42.0)

The Support IPSPG Link Capacity Sharing feature enhances the IPSPG flow control by allowing all of the signaling links on an IPSPG card to share in the Transactions Per Second (TPS) of the card.

Each IPSPG linkset is configured for the **SLKTPS** (also referred to as the **Reserved SLKTPS**) and the **Maximum SLKTPS**. The **Reserved SLKTPS** is the signaling link TPS capacity that is reserved or guaranteed for each link in an IPSPG linkset. The **Maximum SLKTPS** is the maximum TPS capacity that a link is allowed if enough unused capacity is present on the host card. Linksets share available card capacity when presented with a load in excess of the **Reserved SLKTPS** up to the **Maximum SLKTPS** value.

During provisioning, the EAGLE 5 ISS verifies that neither the **Reserved SLKTPS** nor the **Maximum SLKTPS** exceed 5000 TPS and that the sum of the **Reserved SLKTPS** for all of the links hosted by an IPSPG card does not exceed 5000 TPS for the card.

Operation of IPSPG links when IPSPG Link Capacity Sharing is used:

- Links operate independently if their traffic load falls within their respective reserved capacity. The unconsumed portion is available to other links hosted by the same card.

- If the traffic load exceeds the Reserved SLKTPS, then the link can draw from the card unused TPS. If the traffic load exceeds the Maximum SLKTPS for the card, then the link limits processing at the maximum SLKTPS and may enter congestion.
- If the traffic load exceeds the Reserved SLKTPS, and enough card capacity originally existed to allow the link to process the load, but the available card capacity changes so that there is not enough available card capacity to process the load, then the link can enter congestion without affecting other links hosted by the card.
- If multiple links hosted by an IPSG card exceed their Reserved SLKTPS, then the links compete for available capacity on a round-robin basis.

5.131 Support Java 1.5 on ELAP (ELAP 7.0)

Description

The ELAP GUI has been upgraded to be compatible with Java 1.5. The ELAP GUI now requires Java 1.5 or later.

If your browser does not support Java 1.5, when you attempt to connect to the ELAP GUI, your browser will be prompted to install Java 1.5. The Java installation process is described in the *ELAP Administration Manual*.

Hardware Requirements

None.

Limitations

None.

5.132 Support Java 1.5 on EPAP (EPAP 9.0)

Description

The EPAP GUI has been upgraded to be compatible with Java 1.5. The EPAP GUI now requires Java 1.5 or later.

If your browser does not support Java 1.5, when you attempt to connect to the EPAP GUI, your browser will be prompted to install Java 1.5. The Java installation process is described in the *EPAP Administration Manual*.

Hardware Requirements

None.

Limitations

None.

5.133 Support LSMS Disaster Recovery (Release 23.1)

When a disaster occurs and the main **LSMS** is disabled, the user can switch from the main **LSMS** to an optional shadow **LSMS**. The shadow **LSMS** is a geographically remote **LSMS** that actively receives data from the **NPACs**. The shadow **LSMS** serves as a backup to the main **LSMS**. The shadow **LSMS** is continually queuing the transactions for the **OAPs**. The

OAPs are configured to receive data only from the main **LSMS**. Before the switchover can occur, the shadow **LSMS** must be in stable condition. The shadow **LSMS** should have no active alarms or hardware failures and cannot be in the recovery mode with any **NPAC**.

Once the health of the shadow **LSMS** is confirmed, the **OAPs** must be disassociated from the main **LSMS** and associated with the shadow **LSMS**. When an **OAP** tries to establish the association with the shadow **LSMS**, the resynchronization procedure automatically begins.

Before Release 23.1, changing the association of the **OAP** and **LSMS** was performed manually from the **OAP** and often required the assistance of Tekelec Technical Services. This feature allows a user to use the **EAGLE** terminal to change the association of the **OAPs** and the main **LSMS** and shadow **LSMS**. Two new commands have been introduced to change the **OAP LSMS** association, `chg-oap-config` and `rtrv-oap-config`.

```
chg-oap-config
```

The `chg-oap-config` command is used to change the **LSMS** association with the **OAP** in the **EAGLE** database.

```
rtrv-oap-config
```

This command displays **OAP** configuration information in the **EAGLE** database.

Auditing the OAP Database

In order to keep **OAP** database synchronized with the **EAGLE**, a checksum is created using all of the **OAP** configuration data stored on the **EAGLE**. The **OAP** also calculates this checksum based on the data it has. This checksum is returned by the **OAP** with every forced maintenance poll allowing the **EAGLE** to compare and act on the result. If the checksum values do not agree, the **EAGLE** generates a minor alarm (**UAM 0364**) within 10 seconds:

5.134 Support Migration of EPAPs from T1000 to T1200 (EPAP 13.0)

The Support Migration of EPAPs from T1000 to T1200 feature provides the procedure to migrate an existing EPAP 13.0 system running on a T1000 AS to a T1200 AS server.



Note:

The provisioning server should be a T1200 AS, and the non-provisioning servers can be either T1000 or T1200 ASs.

The T1200 AS is connected to the SM cards using switches instead of hubs when compared to a T1000 AS. Using switches allows the software to take advantage of SM4G cards by using a full duplex 100 Mbps connection between the switches and the cards.

The T1200 AS will require new IP addresses if possible, and the software should be fully configured and operational before running health checks or migration procedures.

If new IP addresses cannot be provided for the T1200 AS, the software on the T1200 AS should not be started until the database backups have been copied over, and the T1200 AS has been configured with the IP addresses of the T1000 AS.

Hardware Requirements

A T1200 Application Server is required.

The 830-1104-04 adapters are required for SM4Gs that connect to the T1200 AS.

Limitations

Both the T1000 AS and T1200 AS must be running TPD 3.3.2 and have the same EPAP 13.0 release installed. The T1200 servers must have pre-configured switches, and both systems must be up and running prior to the migration.

5.135 Support of 4 IP Addresses for IPSP Signaling Ports on SLIC card

This permits 4 signaling networks to be connected to a SLIC card, using the third and fourth Ethernet ports (ports C and D) for signaling if not being used for Fast Copy.

The `chg/ent-assoc` and the `chg-eisopts` commands were updated to support this enhancement.

5.136 Support of 750K System (SIGTRAN + ATM) TPS (Release 42.0)

The Support of the 750K System TPS core enhancement consists of four components:

- The maximum allowed system TPS that can be provisioned is increased to 750,000 TPS.
- All TPS-based limitations on the number of IPLIM, IPGW, IPSP, and ATM/E5-ATM cards that are allowed within the EAGLE 5 ISS are removed. The maximum number of cards that can exist on the EAGLE 5 ISS can be added.

Note:

Links cannot be added to a card if the new link would exceed the maximum allowed System TPS.

- The provisioned system TPS is limited using the HIPR2 High Rate Mode feature. If the feature is turned off, then the provisioned system TPS must be less than or equal to 500,000. If the feature is turned on, then the provisioned system TPS must be less than or equal to 750,000. The EAGLE 5 ISS must be configured with HIPR2 cards and the HIPR2 High Rate Mode feature must be turned on before the increased capacities are supported.
- IPLIM card TPS and ATM links TPS are included in the calculation of the total provisioned system TPS.

The provisioned System TPS calculation is calculated by summing the TPS values for the IPGW and IPSP linksets + number of IPLIM cards with provisioned link(s) + the TPS values for the **ATM** links.

If the configuration before upgrade exceeds the maximum allowed system TPS, the EAGLE 5 ISS continues to function as it did before upgrade: however, changes that increase the provisioned system TPS are not allowed. After upgrade, once the system provisioned TPS has reached its allowed maximum, no further changes can be made that will increase the provisioned TPS.

5.136.1 Feature Control Requirements

The HIPR2 High Rate Mode feature (Part Number 893-0201-01) must be turned on before more than 500K TPS can be provisioned in the system.

5.136.2 Hardware Requirements

HIPR2 cards must be installed before more than 500K TPS can be provisioned in the system.

5.137 Support of E1 Master Clock Interface for SS7 Signaling Links (Optional) (Release 22.2)

As an option for Release 22.2, the **E1** Master Clocking **TDM** card provides support for Master **E1** clocking. The **TDM-E1** card supports master clocking of high-speed links at **E1** speeds (2.048Mbits/sec) and provides **E1** clocks to all cards in the **EAGLE** system.

Upgrade Considerations

The following considerations must be taken into account when upgrading to this option:

- Customers with Release 22.2 hardware who want to add the Master Timing support option must upgrade their **TDM** to the **TDM-E1**.
- Customers who choose to upgrade a system currently using **DS-0** links will not have these links available after upgrade when using Master clocking.

5.138 Support of E1 Interface for SS7 Signaling Links (Optional) (Releases 22.2, 24.0)

The **E1** Interface card (**E1/Channel** appliqué) provides a 2.048 Mbit/sec **E1** interface that complies with ITU-T recommendations G.703, G.704, and G.706.

Refer to the *Database Administration Manual - SS7* for current information on this feature.

5.139 Support of IPv6 on EAGLE Query Server (Release 1.0)

The EAGLE Query Server supports the configuration of both IPv4 and IPv6 addresses on provisioned EPAPs in order to establish a connection with the Master and Slave QS, as well as with the MySQL Query Client.

See *Query Server User's Guide* for more information on IPv4 and IPv6 address support.

5.140 Support SCCP on SLIC (Release 46.4)

This feature ports SCCP capability (SCCP64 GPL) to SLIC to achieve 10k TPS.

5.141 Supported Java Client (EPAP 16.0)

The EPAP GUI supports Java 1.7 client.

5.142 Suppression of Gateway Measurements on Non-Gateway Linksets (Release 25.0)

Release 25.0 adds the capability to exclude non-gateway linksets from the P_GTWY schedule. The exclusion can be applied to reports going to the terminal interface, the **SEAS** interface, both, or neither. The P_GTWY measurement schedule allows for the collection and reporting of gateway-related data from the **STP**. The P_GTWY schedule, as currently implemented in the **EAGLE**, provides measurement data on all linksets defined in the linkset table.

This new feature, however, provides the **EAGLE** with the capability of optionally reporting only on linksets that are defined as gateway linksets. Gateway linksets are linksets that have a screenset assigned to them, or that have been defined as gateway linksets via **SEAS**.

The implementation of this feature does not change the measurement data provided by the schedule, but rather controls which linksets are included in the report. This feature also does not change the **SEAS** command interface to the **EAGLE** for the collection of the P_GTWY schedule.

The optional capability is controlled by a new field, `gtwy_ls_fltr`, which is located in the measurement control table, and can be initialized to independently control reports for **EAGLE HMI** and **SEAS** interfaces.

5.143 Synchronous E1 High Speed Link (SE-HSL) (Release 34.0)

Description

The Synchronous E1 High Speed Link (SE-HSL) feature provides “unchannelized” E1 high-speed link interfaces (as defined in ITU-T Q.703 Annex-A) where time-slot 0 is used for framing and error control, and the remainder of the bandwidth equivalent to 31 channels of 64 Kbps data is used as a single data link yielding a total capacity of 1.984 Mbps. SE-HSL links can be used to connect two signaling points that require bandwidth greater than that provided

by 8 low-speed links. The HC-MIM card is used as an SE-HSL card; any 2 of the 8 HC-MIM card ports can be used for SE-HSL E1 interfaces.

The SE-HSL feature supports the following functions:

- Timing modes (external master and line), HDB3 and AMI encoding, and CRC4 encoding.
- Local and line loopback testing at the port level.
- Provisionable FISU/LSSU rate to ensure a minimum density of signaling units on outbound links. The default rate is 1 signaling unit per millisecond.
- The new `apctype` linkset parameter to support changeover messages for ITU National links in China and outside of China.
- A Feature Access Key must be enabled to provide a maximum of 4, 8, 16, 32, 40, 48, 56, or 64 SE-HSL signaling links in the system. A mixture of channelized links and SE-HSL links is not supported on an HC-MIM card.
- Linkset commands—The `rtrv-ls` output shows LSN headings for adjacent point code types ITU-N and ITU-N 24-bit that are used for changeover processing (the `ent-ls` and `chg-ls` commands indicate the type with the new `apctype` parameter).
- E1 commands—The `rtrv-e1` command output shows headings LINKCLASS and MINSURATE (these are new E1 command parameters for SE-HSL). The LINKCLASS parameter indicates whether the HC-MIM card is used for “channelized” E1 links or for “unchannelized” SE-HSL E1 links. In EAGLE 5 SAS Release 34.0, the LINKCLASS parameter default value CHAN (“channelized”) always appears in the `rtrv-e1` output; dashes always appear in the MINSURATE column.
- MTP Level Timer commands—The number of level 2 timer sets has increased from 20 to 30. The `rtrv-l2t` command output shows the default values for the Level 2 timers in each of the 30 timer sets.

Hardware Requirements

The HC-MIM card is used as the SE-HSL card to run software that provides “unchannelized” E1 functions.

Each shelf that contains at least one HC-MIM card must contain HIPR cards in slots `xy09` and `xy10` (`x` is the frame, `y` is the shelf).

Each shelf that contains at least one HC-MIM card must contain a fan tray assembly. The fan feature bit must be turned on in the EAGLE 5 SAS.

Limitations

The SE-HSL feature inherits all the limitations of HC-MIM as listed in the HC-MIM “Limitations” section

The SE-HSL feature does not support the following functions:

- PCR for satellite links
- Link Fault Selection (LFS) testing

During the Changeover/Changeback/Controlled rerouting, the source card on EAGLE 5 SAS buffers the signaling data destined for the concerned link until the Changeover/Changeback/Controlled rerouting procedure is completed. This could take as long as two seconds. Therefore a queue large enough to buffer two seconds worth of data is

required on the source card. When the link is operating at 1 Erlang, two seconds worth of data amounts to 21564 MSUs. An SE-HSL enabled card can support two HSLs, therefore two queues of size 21564 are reserved on the source card.

Another aspect is rerouting the on-hold data off the source card. Rerouting this much data has ramifications associated with it. SE-HSL supports buffering and rerouting at 0.4 Erlang to avoid the possibility of congestion or discard. Above 0.4 Erlang, buffering and rerouting may result into congestion or loss of data.

SE-HSL supports timers T1-T6 values up to 550 milliseconds. However, setting the T1-T6 times to 550 msec opens a possibility for mis-sequencing. EAGLE 5 SAS supports only one Layer 3 timer set. Once provisioned for high-speed links, all the links in the system use the T1-T6 limit of 550 milliseconds.

5.144 Synchronous T1 High Speed Link (Release 41.0)

The Synchronous T1 High Speed Link (**ST-HSL-A**) feature provides support for a high speed link, referred to as an ST-HSL-A link, on an unchannelized T1 card.

5.144.1 Feature Control Requirements

The ST-HSL-A feature is a quantity-controlled feature. FAK numbers are used to provision the number of ST-HSL-A links that can be enabled on the EAGLE 5 ISS. After a quantity has been provisioned, a lower quantity cannot be provisioned.

Table 5-23 ST-HSL-A Quantities

Number of ST-HSL-A Links	FAK
4	893-0273-01
8	893-0273-02
16	893-0273-03
24	893-0273-04
32	893-0273-05
40	893-0273-06
48	893-0273-07
56	893-0273-08
64	893-0273-09
72	893-0273-10
80	893-0273-11
88	893-0273-12
96	893-0273-13
104	893-0273-14
112	893-0273-15
120	893-0273-16
128	893-0273-17
136	893-0273-18
144	893-0273-19
152	893-0273-20
160	893-0273-21
168	893-0273-22

Table 5-23 (Cont.) ST-HSL-A Quantities

Number of ST-HSL-A Links	FAK
176	893-0273-23
180	893-0273-24

5.144.2 Hardware Requirements

The ST-HSL-A feature requires E5-E1T1 cards.

The E5-E1T1 card supports 1 ST-HSL-A link. Support for the ST-HSL-A link is combined with the support for the current channelized and unchannelized links. Supported link types cannot be mixed on the same active card.

5.145 TALI "A" Link Connectivity (Release 28.0)

Description

This feature provides the capability to interface the **EAGLE STP** with an **SCP** by utilizing the **TALI/IP** protocol stack and the **TCAP-over-IP** feature of the merged Secure Gateway code. Specifically, this feature provides a **TCAP-over-IP** interface for **SCP** connectivity using **TALI 3.0**. This will allow the **EAGLE** to perform the **SS7** interface functions of the **SCP**, eliminating the need for the **IP7** Front End in this application.

The **EAGLE STP** uses the following features from the **IP7** Secure Gateway feature set.

- **TCAP Over IP** Gateway Connectivity to **IP-SCPs**
- Feature key support
- **TALI 3.0**

The **TCAP-over-IP** feature allows **SS7** nodes to exchange **SCCP/TCAP** Query/Responses with an **IP** enabled **SCP**. The Secure Gateway will map the **Point Code/SSN** to one or more **TCP** sessions, convert the **SS7 MSUs** to **TCP/IP** packets by embedding the **SCCP/TCAP** data inside a **TCP/IP** packet, and route it over an **IP (IPGTWY)** network.

For more information on the **TALI A Link** Connectivity feature, refer to the **Database Administration Manual - SS7**.

New Hardware Required

No new hardware is required for this feature.

5.146 TALON Development Kit (IP⁷ Release 2.0)

Release 2.0 of the **IP⁷** Secure Gateway also optionally includes the **TALON** Release 2.0 Development Kit. This kit includes:

- iGate, which includes:

- iGate clients, which provide the client-side implementation of the Transport Adapter Layer Interface (**TALI**) protocol, Release 2.0.
- Application message queues, which hold messages sent between the iGate clients and the customer's application.
- iGate controller, which controls starting and stopping of iGate clients.
- iGate command line interface, through which the user enters commands to start up, shut down, and reconfigure iGate components, to send **TALI** service and management messages, and to obtain status and measurements.
- **TALON** Assessor, a tool used to test and verify an implementation of the **TALI** Release 2.0 protocol. The Assessor can implement both sending and receiving messages as either a **TALI** client or server, as well as provide logging and measurements.
- **ISDN** User Part (**ISUP**) Access Library, a collection of C++ classes that allow customers to rapidly develop C++ applications that need to encode and decode **ISUP** messages. This library allows customer's applications to either set or get the value of an **ISUP** message or parameter without needing to directly access the bit stream of the **ISUP** message. Customers can compile their applications in the library, connect to **TALON** iGate queues, and then receive, parse, process, and send **ISUP** messages.

For more information about the **TALON** Development Kit, refer to the **TALON** Release 2.0 User Manual, which is included on the **CD-ROM** that contains the **TALON** software.

5.147 TCAP Opcode Based Routing (Release 41.0)

The TCAP Opcode Based Routing (**TOBR**) feature allows GTT routing to be based on information in the TCAP portion of ANSI or ITU messages or on the SCCP Called Party Subsystem Number (**CdPA SSN**).

For ITU messages, the information in the TCAP portion includes ITU TCAP package type, application context name, and operation code. For ANSI messages, the information includes ANSI TCAP package type, family, and operation code specifier.

All UDT, UDTS, Unsegmented XUDT, and Unsegmented XUDTS queries are supported. Segmented XUDT messages are supported for SSN routing.

TCAP Segmented SMS Support Phase 2

The TOBR feature allows all segmented TCAP SMS messages within a transaction to be routed to the same destination. The messages are routed based on the TCAP OpCode and Dialogue portion of the message.

5.147.1 Feature Control Requirements



Note:

The TOBR feature is not quantity based: however, a quantity-based FAK is used to determine the number of Opcode translations that are allowed in the system.

Feature control requirements for the TOBR feature include:

- The FLOBR feature must be turned on before the TOBR feature can be enabled.

- A FAK for Part Number 893-0278-01
- The appropriate FAK for the desired quantity:
 - 3 opcode translations (893-0279-01)
 - 6 opcode translations (893-0279-02)
 - 12 opcode translations (893-0279-03)
 - 24 opcode translations (893-0279-04)
 - 48 opcode translations (893-0279-05)
 - 96 opcode translations (893-0279-06)
 - 1 million opcode translations (893-0279-07)
- Quantity FAKs must be entered in ascending order. After a quantity is provisioned, a lower quantity cannot be provisioned. The quantities do not have to be provisioned sequentially.
- A temporary FAK cannot be used to enable the feature.
- The feature cannot be turned off after it has been turned on.

5.147.2 Hardware Requirements

The TOBR feature requires E5-SM4G or higher cards.

5.148 TCAP Segmented SMS Support Phase 1 (Release 39.0)

The TCAP Segmented SMS Support Phase 1 enhancement allows the Portability Check for MO SMS and MO-based GSM SMS NP features to correctly process TCAP Segmented SMS messages. If a segmented message is subjected to the service associated with either of these features, then the EAGLE 5 ISS routes the initial TC_Begin message using standard GTT processing. The subsequent TC_Continue message is subjected to the specified service.

For MO-based GSM SMS NP, the TC_Continue message is routed to the short message service center (**SMSC**) with a modified B-Party address. The redirection option in the MO-based GSM SMS NP feature is not supported for segmented messages, even with this enhancement.

For Portability Check for MO SMS, the EAGLE 5 ISS determines whether to route or discard the TC_Continue message. If the TC_Continue message is discarded, then the EAGLE 5 ISS also properly closes the open transaction at both the MSC and SMSC by sending a TC_End and a TC_Abort message, respectively. If the TC_Continue message is not discarded, then the EAGLE 5 ISS relays the message to the SMSC indicated by GTT.

5.148.1 Feature Control Requirements

The GTT feature and either the Portability Check for Mobile Originated SMS or the MO-based GSM SMS NP feature must be turned on before the TCAP Segmented SMS Support Phase 1 enhancement can be provisioned.

5.148.2 Hardware Requirements

There are no additional hardware requirements for this feature.

5.148.3 Limitations

No limitations are associated with this feature.

5.149 TDM Global Timing Interface (Release 31.6)

The **TDM** Global Timing Interface (**TDM-GTI**) is used with an enhanced, backward compatible, **TDM** card providing the following added functions:

- Ability to generate high speed master clocks from a recovered **E1/T1** clock
- Ability to optionally reload the clock Logic Cell Array (**LCA**) bitfile when the mated **GPSPM-II** is initialized.

TDM-GTI provides the ability to generate high speed master clocks from a recovered **E1/T1** clock, in addition to the **RS422** clock.

5.150 Temporary Alarm Inhibiting and Offline Functions (Release 25.0)

Overview

These features provide a two-part enhancement to the Selective **Alarm** Inhibit feature introduced with Release 22.0. First, the craftsperson can choose to have an alarm inhibited until the problem is fixed and the alarm clears (Temporary **Alarm** Inhibiting).

Second, these features give the craftsperson the mechanism for inhibiting critical alarms (Offline Functions). This is useful when a critical alarm has been investigated, the cause is known, and the critical alarm expected based on the current network. By allowing acknowledgment of specified critical alarms, new critical alarms are not masked.

Currently, alarms are inhibited until the inhibit is manually removed (Permanent Inhibit). Temporary **Alarm** Inhibiting lets the user specify a temporary inhibit indicating that the inhibition of the alarm should be cancelled when the condition clears. This allows a new occurrence of the same alarm to be issued.

A craftsperson may choose to inhibit existing alarms or future alarms in order to focus on higher severity or unknown alarms. A craftsperson may choose to inhibit alarms for various reasons, including:

- In a special maintenance situation where repeated alarms from malfunctioning equipment would tend to mask more critical unknown alarms (e.g. an out-of-service link due to a physical break that cannot be repaired for days).
- In the situation where the system is being provisioned. Currently alarms are generated immediately after entities are entered into the database. The craftsperson probably ignores these alarms while the system is being configured. Ignoring alarms due to entry of entities could result in the masking of alarms that may require immediate attention.

- In a situation where the craftsperson, while working on repeating alarms from malfunctioning equipment, might tend to mask more critical additional alarms. The craftsperson will want to temporarily inhibit the repeating alarms. When the repeating alarm is cleared, it will be uninhibited, and the craftsperson will be able to see it if it reoccurs.
- In a situation where a device is going to be put offline, or is offline and the repeated critical alarms associated with the offline equipment would tend to mask more critical alarms.

The method for inhibiting alarms is the same, regardless of the reason for inhibition. The craftsperson can either turn off (i.e. Temporary Inhibit or Permanent Inhibit) or turn on (i.e. Uninhibit) specified alarms through command entry. Permanent alarms are persistent.

Alarm System Functionality

There are four **Alarm** Indicators and one Control/Status display in the system. The fuse panels and row panels have lights to indicate alarms. The Local Maintenance Center and Remote Maintenance Center have signals that can be monitored for alarms.

All of these indicators have separate lines for critical, major, and minor alarms. The Control/Status Display is in the Status Area of the **VT320** Screen. The same data is available through the `rept-stat-alm` command.

Figure 5-28 Alarm Indicators

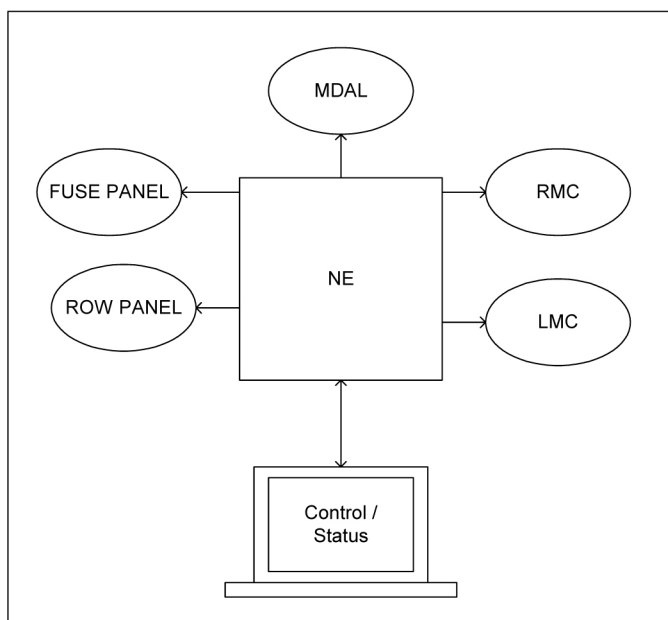

Customer Use Scenario

A typical case where these features are needed follows:

- In an office with alarms that cannot be repaired quickly, "stuck alarm" (e.g. a cut link)...

- and only the remote maintenance center will be monitoring the alarms.

Because the alarms have not been repaired, all the indicators continue to be active (i.e. lights/signals on). When a new alarm arrives that is not for the device that has the "stuck alarm," the **RMC** indicator cannot accurately inform the maintenance personnel that a new alarm has occurred.

These features allow the maintenance personal to inhibit the "stuck alarm" that will turn off the appropriate alarm indicators. Now, at the **RMC**, the indicators will be cleared (i.e. lights off), and any alarm generated for a device that does not have its alarms inhibited will activate the indicators (i.e. lights on).

The mechanism for clearing the indicators is by inhibiting the alarms for the failed devices. When all devices that have alarms have had their alarms inhibited, the indicators are cleared.

The **RMC** indicators in the following table presents one possible scenario that illustrates the use of the inhibit alarm feature (i.e. Offline Functions) Without the ability of having a cleared indicator, the **RMC** personnel might not react as quickly as possible to the subsequent link failure.



Note:

This example does not address the output generated to the **RMC** maintenance channel. When link 4107 port B failed, the system generated the appropriate output message.

Table 5-24 Example of Inhibit Alarms Use

ACTION	CONTROL COUNTS (Inhibited)			RMC INDICATOR		
	CRIT	MAJR	MINR	CRIT	MAJR	MINR
System clear -- no failed devices in the system	0	0(0)	0	off	off	off
A span is cut at 4:50pm -- cannot be repaired for 10 hours						
Link 1201, A generates alarm because of physical failure	0	1(0)	0	off	ON	off
Link 2318, B generates alarm because of physical failure	0	2(0)	0	off	ON	off
Link 5205, B generates alarm because of physical failure	0	3(0)	0	off	ON	off
Link Set Is1234 generates alarm because all links in link set are Out of Service	0	4(0)	0	off	ON	off
User inhibits alarm for link set Is1234	0	4(1)	0	off	ON	off
User inhibits alarm for link 1201,A	0	4(2)	0	off	ON	off
User inhibits alarm for link 2318,B	0	4(3)	0	off	ON	off
User inhibits alarm for link 5205,B	0	4(4)	0	off	off	off
User turns control over to the Remote Maintenance Center for the night.						

Table 5-24 (Cont.) Example of Inhibit Alarms Use

ACTION	CONTROL COUNTS (Inhibited)			RMC INDICATOR		
	CRIT	MAJR	MINR	CRIT	MAJR	MINR
New alarm -- Link 4107, B fails not due to physical span failure	0	5(4)	0	off	ON	off
RMC reacts to the event and investigates the failure						

The scenario presented in the following table illustrates the use of the temporary inhibit alarm feature. Without the ability of having a cleared indicator, the **RMC** personnel might not react as quickly as possible to the subsequent link failure.



Note:

This example does not discuss the output generated to the **RMC** maintenance channel. When link 4107 port B failed, the system generated the appropriate output message.

Table 5-25 Example of Temporary Alarm Inhibit Use

ACTION	CONTROL COUNTS (Inhibited)			RMC INDICATOR		
	CRIT	MAJR	MINR	CRIT	MAJR	MINR
System clear -- no failed devices in the system	0	0(0)	0	off	off	off
A span is cut at 4:50pm – cannot be repaired for 10 hours						
Link 1201, A generates alarm because of physical failure	0(0)	1(0)	0	off	ON	off
Link 2318, B generates alarm because of physical failure	0(0)	2(0)	0	off	ON	off
Link 5205, B generates alarm because of physical failure	0(0)	3(0)	0	off	ON	off
Link Set ls1234 generates alarm because all links in link set are Out of Service	0(0)	1(0)	0	off	ON	off
DPC prohibited critical alarm	1(0)	4(0)		ON		
User temporarily inhibits critical alarm	1(1)	4(0)		off		
User temporarily inhibits alarm for link set ls1234	1(1)	4(1)	0	off	ON	off
User temporarily inhibits alarm for link 1201,A	1(1)	4(2)	0	off	ON	off
User temporarily inhibits alarm for link 2318,B	1(1)	4(3)	0	off	ON	off
User temporarily inhibits alarm for link 5205,B	1(1)	4(4)	0	off	off	off
User turns control over to the Remote Maintenance Center for the night.						

Table 5-25 (Cont.) Example of Temporary Alarm Inhibit Use

New alarm – Link 4107, B fails not due to physical span failure	1(1)	5(4)	0	off	ON	off
RMC reacts to the event and investigates the failure	1(1)	5(4)	0	off	ON	off
Link 4107, B failure and physical span failure corrected.	1(1)	4(4)	0	off	off	off
Link 1201, Span fixed, alarm cleared	1(1)	3(3)	0	off	off	off
Link 2318, Span fixed, alarm cleared	1(1)	2(2)	0	off	off	off
Link 5205, Span fixed, alarm cleared	1(1)	1(1)	0	off	off	off
Link Set Is1234 has no failed links, all alarms cleared.	1(1)	0(0)	0	off	off	off
DPC prohibited – critical alarm cleared	0(0)			off	off	off
A span is cut at 4:00 am – cannot be repaired for 10 hours						
Link 1201, A generates alarm because of physical failure	0(0)	1(0)	0	off	ON	off
Craftsperson knows the span failure has reoccurred.						

Administration

Two commands, `inh-alm` and `unhb-alm`, which were created in Release 22.0, have been enhanced to accommodate the Temporary Inhibit feature and the Offline Functions feature in Release 25.0. These changes allow for the following:

- The craftsperson will be allowed to temporarily inhibit the alarms on a device. The alarms will be inhibited until the alarm is cleared, at which point the device's alarms no longer will be inhibited.
- If a device's alarms are inhibited, the craftsperson will not be able to re-inhibit the same device's alarms. This is important for the scenario where the craftsperson tries to change a permanently inhibited alarm on a device to be temporarily inhibited. The craftsperson must uninhibit the alarms and inhibit them more precisely.
- A craftsperson is provided with a mechanism to inhibit critical alarms. This mechanism includes first allowing the **STP** option `critalminh`, which allows the inhibiting of critical alarms.
- When a craftsperson inhibits an alarm and specifies that critical alarms will be inhibited, the effect is that critical, major and minor alarms are all inhibited. If the craftsperson inhibits an alarm and specifies that major alarms will be inhibited, the effect is that major and minor alarms are all inhibited.

See [Thresholding of UIM Messages \(Release 25.0\)](#) for more information on the `inh-alm` and `unhb-alm` commands.

Administration Rules:

1. A device must exist as a database or system-fixed entity.
2. You cannot inhibit an already inhibited device.
3. You cannot uninhibit an uninhibited device.

4. Normal database rules apply for an administration change to the database.

The command handler parameter combinations for the `inh-alm` and `unhb-alm` appear in the following table.

Table 5-26 Device/Parameter Command Matrix

	No para meter s	LOC	PORT	LSN	ID	DPC	DPCA	DPCI	DPCN
CARD		1101..6118							
SLK		1101..6118	A and B						
LS				Link Set Name s					
ROUTE						nnn-ccc- mmm	nnn-ccc- mmm	z-aaa- i	nnnnn
TRM			1..16						
SYSCLK	No param eters								
DLK		1101..6118							
CDT					1..16				
LSMSQ3			A1,A2,B 1, B2						
SEASX2 5			A1,A2,B 1, B2						

Maintenance

There are several actions that the maintenance system must control:

- Visual Indicator Control
- Visual Control Area banner display of the inhibited alarm count
- Suppression of alarm output
- Generation of Inhibit Message
- `rept-stat` command changes
- Hourly Status Report changes

Each is discussed in the following sections.

Control Area Changes

There are four boxes on the **VT320** Control Area, of which only three were used prior to Release 21.0. The fourth currently displays the number of devices that have alarms inhibited. Viewed from left to right on the screen, they indicate Critical, Major, and Minor alarms, and the number of devices that have alarms inhibited.

Suppression of Output

Suppression of the output occurs when the function call is made to "generate unsolicited alarm output." This prevents any changes to the analysis code. Within the "generate unsolicited output," the action has been changed to "generate unsolicited alarm with no output." This function is used during **OAM** initialization to set alarms without generating output, and effectively suppresses the output.

New UAMs

Two **UAM**'s inform the user that the device has had its alarms inhibited:

```
RLGHNCXA03W 99-07-07 00:57:31 EST Rel 25.0.0
0100.0294 CARD 1201 SS7ANSI REPT-ALMINH: alarm output Perm
inhibited
;
RLGHNCXA03W 99-07-07 00:57:31 EST Rel 25.0.0
0100.0296 CARD 1201 SS7ANSI REPT-ALMINH: alarm output Temp
inhibited
;
```

Status Command Changes

Device Status Commands

The associated state of a card is displayed as "**ALMINH**" when a card's alarms are inhibited.

The 'stat' option for these commands has been extended to support '**ALMINH**', which displays all cards whose alarms are inhibited. When the Associated State is set to **ALMINH**, it is overwritten by other states (e.g. **BIP**) until the inhibition is removed.

See the *Commands Manual* for more information.

Hourly Status Report

The Condition Type field in the Hourly Status Report has the **INHAUDB** value added to possible values. The full list of Condition Types follows.

1. **SCMMA** - The device has been disabled due to manual maintenance action (e.g. `inh-card`). This condition applies regardless of previous alarm state.
2. **MTCEINT-0** - The reported device is off-normal (**ANR**), but there is no alarm associated with this device. An alarmed condition for another device typically impacts the state of this device, e.g. **OOS** links affect linksets, **OOS DLKs** affect **SLAN** cards.
3. **MAN** - The reported device is off-normal (**OOS-MT**), but there is no alarm associated with this device. The off-normal condition was caused manually, e.g. `ent-dstn` command entry.
4. **NULL** - No specific 'cond type' is currently supported for this release. There is sufficient information to ascertain the device condition from the report. The craftsperson may use `rept-stat-xxx` command(s) to collect further information.
5. **INHAUDB** - The user has manually inhibited alarms for this device. The time when the device was inhibited is recorded, and displayed during the hourly report.

The Hourly Status Report includes the alarm status periodic reminder added at its end. A new status indicates alarms that have been inhibited.

Output Example

```

RLGHNCXA03W 99-07-07 00:57:31 EST Rel 25.0.0
5023.0000 REPT COND CARD
"CARD 1201:,MTCEINT-0,,96-11-19,14:58:24,,,,,"
"CARD 1202:0013,,SA,96-11-19,14:44:38,,,,**"
"CARD 1203:0013,,SA,96-11-19,14:44:38,,,,**"
"CARD 1204:0013,,SA,96-11-19,14:44:38,,,,**"
"CARD 1206:0013,,SA,96-11-19,14:44:38,,,,**"
"CARD 1207:0034,,NSA,96-11-19,14:52:56,,,,* "
"CARD 1208:0013,,SA,96-11-19,14:44:38,,,,**"
"CARD 1216:0013,INHAUDB,NSA,96-11-19,13:44:38,,,,,"
"CARD 1101:0034,MTCEINT-0,NSA,96-11-19,14:52:56,,,,* "
"CARD 1115:0143,,NSA,96-11-19,14:57:52,,,,* "

RLGHNCXA03W 99-07-07 00:57:31 EST Rel 25.0.0
5034.0000 REPT COND ALARM STATUS
"ALARMS:TEMP INHIBITED,1,3,4"
"ALARMS:PERM INHIBITED, 2,14,4"
"
"ALARMS:ACTIVE,2,0,0"
"ALARMS:TOTAL,5,17,8"
"ALARMS:STATUS,AUDIBLE,SILENT,SILENT"

```

Note that the alarm status is shown in the following sequence: critical, major, and minor. Thus the bold text means there are two critical alarms, fourteen major alarms, and 4 minor alarms.

5.151 Thresholding of UIM Messages (Release 25.0)

Description

This feature suppresses the generation of a **UIM** message when it exceeds a certain user-settable threshold. It allows the user to set, delete, or display the **UIM** threshold and interval on a per-**UIM** number basis.

The thresholding capability provided by this feature is limited by the systemwide threshold of 4 **UIMs** per second, i.e. any threshold set using this new feature is superseded by the systemwide threshold, which is not administrable.

In support of this feature, the following commands have been created:

- `set-uim-acthresh` (to set **UIM** threshold and interval)
- `rtrv-uim-acthresh` (to display the **UIM** threshold and interval)
- `dlt-uim-acthresh` (to delete the **UIM** threshold and interval)

In addition, a **UIM** logging feature has been introduced primarily as a complement to the **UIM** Thresholding feature. (The **UIM** Thresholding feature allows for the suppression of **UIM** messages when they exceed a certain user settable threshold.

The user can define the threshold such that no **UIM**'s will be displayed.) The new logging feature provides a way to retrieve all the **UIM** messages that would have been printed, even those not displayed due to the **UIM** threshold feature.

The craftsperson can retrieve the logged **UIMs** with the `rtrv-log` command, using the new value "**UIM**" for the `type` parameter.

The **UIMs** are stored on disk only by the active **OAM**. However, the **UIMs** that were stored on the standby when it was active can be retrieved with the `rtrv-log` command.

UIM logging occurs on a continuous basis. When the **UIM** log is full, the oldest event is overwritten by the newest event. A total of 65,536 **UIMs** can be maintained in the log. This represents a history of time of 4.55 hours, at a maximum creation rate of 4 **UIMs** per second. The term "creation rate" is defined here as **UIMs** that are printed or would have been printed if the **UIM** Threshold feature was not used.

Creation of UIMs

Figure 5-23 shows how **UIMs** are generated throughout the system. It is important to note that the point where the decision is made to discard **UIMs** due to thresholding has changed with this feature.

The applications running on cards send **UIMs** and alarms to the **ATH** application. The **ATH** application on every card is polled by **STH** every 1.28 seconds for the **UIM** and **Alarm** information on those cards. Each **ATH** has a buffer of a total of 10 **UIMs** and Alarms it can send to the **STH** during that interval. The **STH** forwards all the **UIMs** to **SIH** for handling. **SIH** processes 6 **UIMs** every 20ms. If **SIH** decides the **UIM** should be printed, it places the **UIM** on the **HI** or **LO** queues. **SIH** then paces the output to **UI** at a rate of approximately 4 **UIMs** per second.

Figure 5-29 Depiction of UIM Creation, Logging, and Thresholding

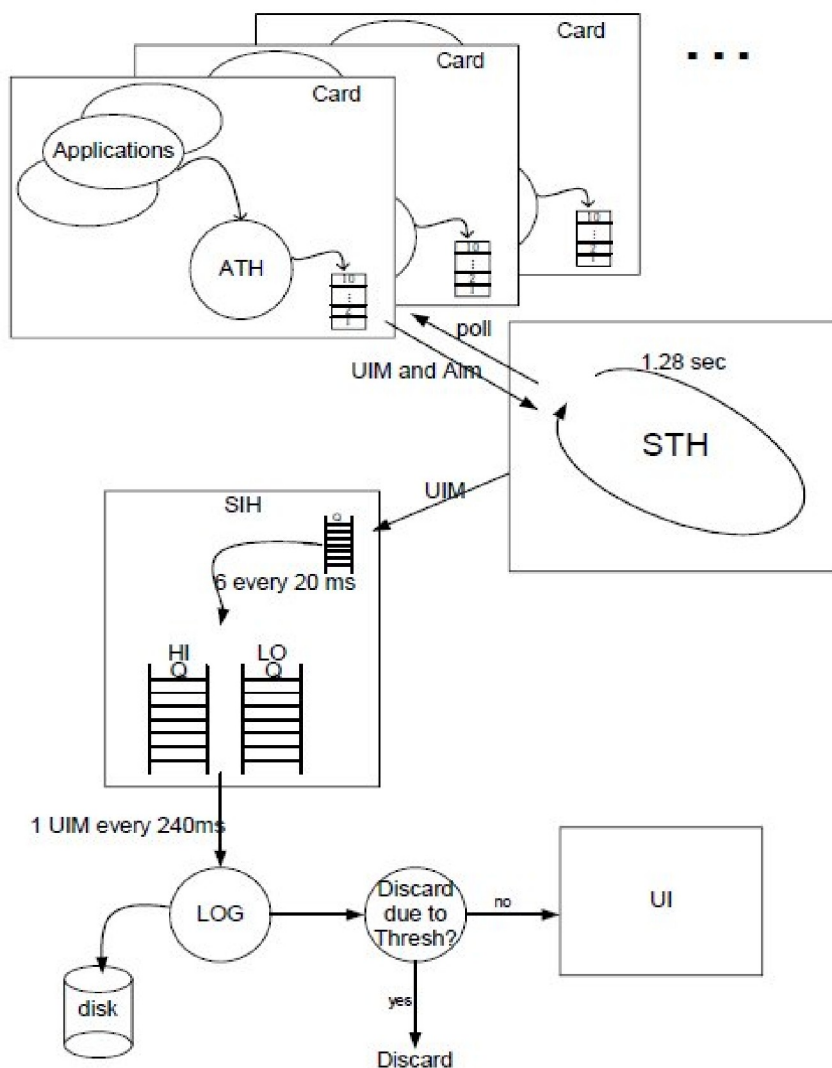

Upgrade Considerations

The **UIM** logging feature requires that a new file be created and initialized during upgrade from any pre-release 25.0 **EAGLE**. This new file holds the history of **UIM** events. If this file is not created in a release 25.0 **EAGLE**, the **OAM** will detect the absence of the file and automatically disable logging. The **OAM** does so by entering the **DISABLED** logging-state, and will remain in that state until the **OAM** reboots and can then access the file. If the **OAM** is in the **DISABLED** logging state for **UIM** logging, it means it can not log **UIMs**.

The new file is 11 Mbytes in size and can hold 65,536 **UIMs**.

Changed Event Log Command

The `rtrv-log` command retrieves records from one of the logs generated by the Maintenance system; it selects these records based on a span of time or a specific log file index.

Prior to Release 25.0, the only log supported was the **Alarm** Log.

As of Release 25.0, the `type` parameter can be used to retrieve the events of either the **Alarm** log (`type=alarm`) or the **UIM** log (`type=uim`), but not both. The default is `alarm`.

Refer to the *Commands Manual* for current usage information.

Limitations

The implementation of the **UIM** logging feature contains the following limitations. These limitations may need to be communicated to the Customer and are candidates for future feature enhancements:

1. Due to the fact that the **HI** priority queue gets serviced before the low priority queue in **SIH**, the events may not be logged in the order in which they occurred (put another way, their timestamps might not be ordered due to the nature of **SIH**). Also, when the time/date is changed (e.g. with the set-time command) the display of these records may appear (from the date-time stamp) to been written in the incorrect order. Taking both these into consideration, there is a timestamp for when the **UIM** occurred and when the **UIM** was logged. This aids the retrieval of **UIMs**.
2. The information in the Log is not self-evident. Technical documentation and/or files must be provided to allow such a file to be analyzed off the **EAGLE**.
3. **UIMs** are written only to the **UIM** Log on the active **OAM**. However, events that were logged previously on the current standby (when it was the active) can be retrieved with the `rtv-log` command.
4. The writing of **UIMs** to the Log will continue, unaffected, during a removal of the Log via either a `copy-tbl` or with the Kermit facility.
5. The Log will not be included in the **BACKUP/RESTORE** capability.
6. The repairing of the Log must be accomplished by a `copy-tbl` command from the removable, should the Log become corrupted.

5.152 TIF Calling Party Number Conditioning (Release 44.0)

The Triggerless ISUP Framework (**TIF**) is enhanced to add TIF Calling Party Numbering Plan Processor (**NPP**) services. This enhancement allows NPP to be called separately for Called Party numbers (**CdPN**) and Calling Party numbers (**CgPN**), and allows the CgPN access to all NPP conditioning and formatting controls.

The TIFCGPN, TIFCGPN2 and TIFCGPN3 NPP services are added for TIF CgPN Numbering Plan Processing. These services are invoked using the CgPN portion of an ISUP IAM message.

The ASDOTHER and GRNOTHER Formatting Actions are added to support TIF CgPN Conditioning. The ASDOTHER Formatting Action allows the Additional Subscriber Data (ASD) returned from an RTDB search in the ASDLKUP Service Action for a TIF CgPN service to be used in CdPN formatting. The GRNOTHER Formatting Action allows the Generic Routing Number (GRN) returned from an RTDB search in the GRNLKUP Service Action for a TIF CgPN service to be used in CdPN formatting.

A TIF CdPN NPP service can invoke a TIF CgPN NPP Service. TIF CgPN NPP services are tied to TIF CdPN NPP services (TIF, TIF2, TIF3) in a one-to-one manner. For example, if an MSU is filtered by the TIF2 GWS stop action, then the TIF2 NPP service is invoked based on the CdPN portion of the message. The TIF2 NPP Service Action processing can then invoke the TIFCGPN2 NPP Service using the CgPN portion of the message.

The TIF Additional Subscriber Data, TIF Generic Routing Number, TIF Number Substitution, and TIF Simple Number Substitution features and various existing Service Actions are enhanced to support TIF CgPN Conditioning. Refer to the *Feature Manual - TIF* and to the *Numbering Plan Processor (NPP) Overview* for the Release 44.0 Documentation Set for additional information.

5.152.1 Hardware Requirements

TIF CgPN Number Conditioning requires Service Module cards.

5.153 TIF NP Service Portability (Release 41.1)

Service Portability support for TIF NP applies to TIF Number Portability (NP) Relay and TIF **NP** Release. This support determines whether the GRN from the RTDB lookup is used by the NPRELAY and the NPRLS Service Actions, respectively.

Note:

The NPRELAY and NPRLS Service Actions are no longer mutually exclusive. They can be provisioned in the same Service Action set.

The TIFOPTS NPTYPE configuration parameter is expanded to two TIFOPTS parameters, NPTYPERLY and NPTYPERLS. The NPTYPERLY option determines the network entity type behavior for the NPRELAY Service Action and the NPTYPERLS option determines the network entity type behavior for the NPRLS and NPNRLS Service Action. This expansion allows configuration of the release and relay Service Actions for non-ported subscribers and ported subscribers independently.

SPFILL

An SPFILL option is introduced for the TIF NP feature. This option indicates whether SP digits are used if the Default Routing Number (Default RN) or the Generic Routing Number (GRN) is used for local subscribers. If the SPFILL option is on, then the RTDB network SP entity digits are populated. This option can be provisioned whether Service Portability is supported or not.

5.154 TIF Number Portability (Release 39.2)

The TIF Number Portability feature uses the [Triggerless ISUP Framework \(Release 39.2\)](#) (**TIF**) to perform number portability functions.

Note:

The TIF Number Portability feature is used to replace the TINP feature. Only customers that had the TINP feature enabled prior to upgrading to 39.2 can use the TINP feature after upgrade has occurred. All other customers will use the TIF Number Portability feature.

The TIF Number Portability feature includes the following capabilities:

- **Terminating Actions**
Number portability can be performed on called party numbers (CdPNs), and either the Relay or Release termination action can be provisioned as the result.
- **Circular Route Prevention**
Circular Route Prevention is used when circular routing is caused by incorrect information in one or more networks' number portability databases. If the routing number (**RN**) of the called number is the RN of the network receiving the message (the incoming RN is found in the HomeRN list.), then if the result of the **RTDB** lookup is another RN, a loop is detected and the call is released.
- **Enhanced CgPN Lookup**
Calling party number lookup can be performed for certain call types.
- **Filtering**
A combination of Gateway Screening and TIF filters can be used to select the Service Actions required.
- **Number Conditioning for EPAP Database Lookups**
Prefixes can be deleted from a number string and used for either RTDB lookup or in formatting the outgoing message.
- **Release Handling**
The Release message can be configured to include the redirection number.

5.154.1 Feature Control Requirements

The TIF Number Portability feature has the following feature control requirements:

- FAK for part number 893-0189-01
- The GTT feature bit must be turned on before the feature can be enabled.
- The Gateway Screening feature bit must be turned on before the feature can be enabled.
- The feature cannot be turned off after it has been turned on.
- A temporary FAK cannot be used to enable the feature.

5.154.2 Hardware Requirements

The TIF Number Portability feature requires Service Module cards. The feature cannot be enabled if TSM cards running the **sccp** application are provisioned in the system. TSM cards running the **sccp** application cannot be provisioned if the TIF Number Portability feature is enabled.

5.154.3 Limitations

No limitations are associated with this feature.

5.155 TIF Number Substitution (Release 41.0)

The Triggerless ISUP Framework (**TIF**) Number Substitution feature allows called party and/or calling party numbers on an incoming Initial Address Message (**IAM**) to be substituted with associated numbers from the RTDB on the outgoing IAM.

When an IAM is received, a lookup is performed on the called party number (**CdPN**) or calling party number (**CgPN**) in the RTDB database. If a successful retrieval of the called party

directory number (**DN**) occurs, then the CdPN is substituted in the outgoing IAM. If a successful retrieval of the calling party DN occurs, the CgPN is substituted in the outgoing IAM

The feature introduces the **nscdpn** and **nscgpn** Service Actions, which are used to perform a lookup for the incoming CdPN and CgPN, respectively. These Service Actions are used with the Numbering Plan Processor (**NPP**). For information on the Numbering Plan Processor and TIF, refer to the *Numbering Plan Processor (NPP) Overview* and the *Feature Manual - TIF*, respectively, of the latest EAGLE 5 ISS documentation set.

5.155.1 Feature Control Requirements

Feature control requirements for the TIF Number Substitution feature include:

- A FAK for Part Number 893-0225-01
- The feature cannot be enabled if the ELAP LNP Configuration feature is enabled.
- The feature cannot be enabled with a temporary FAK.
- The feature can be turned on and off.

5.156 TIF Range CGPN Blacklist (Release 44.0)

The TIF Range CgPN Blacklist feature generates an ISUP RELEASE (ISUP REL) message back to the originator of an incoming IAM message based on the Calling Party Number (CgPN) if one of the following conditions exists:

- A CgPN beginning with a specific prefix is found during Numbering Plan Processing (NPP).
- The CgPN parameter is not present in the IAM.
- The CgPN parameter is present but does not contain any digits.
- An NPP rule to generate an ISUP REL message is found for the Calling Party Number.

Two new CgPN Service Actions are created to support this feature:

- FPFXRLS-generate an REL message if a Calling Party rule is found in NPP
- NOCGPNRLS-generate an REL message if the Calling Party is not present in the IAM or is present with no digits

5.156.1 Feature Control Requirements

- FAK for Part Number 893-0377-01
- The GTT feature must be turned on before the TIF Range CgPN Blacklist feature can be enabled.
- The Gateway Screening feature must be turned on before the TIF Range CgPN Blacklist feature can be enabled.
- A temporary FAK cannot be used to enable the feature.
- The feature can be turned on and off.

5.156.2 Hardware Requirements

The TIF Range CgPN Blacklist feature requires Service Module cards.

5.157 TIF SCS Forwarding (Release 39.2)

The TIF SCS Forwarding feature allows messages to be forwarded to the Tekelec Service Creation System (**SCS**) after [Triggerless ISUP Framework \(Release 39.2\)](#) (TIF) processing has completed.

5.157.1 Feature Control Requirements

The TIF SCS Forwarding feature has the following feature control requirements:

- FAK for part number 893-0222-01
- The GTT feature bit must be turned on before the TIF SCS Forwarding feature can be enabled.
- The Gateway Screening feature bit must be turned on before the TIF SCS Forwarding feature can be enabled.
- A temporary FAK cannot be used to enable the feature.

5.157.2 Hardware Requirements

The TIF SCS Forwarding feature requires Service Module cards. The feature cannot be enabled if TSM cards running the **sccp** application are provisioned in the system. TSM cards running the **sccp** application cannot be provisioned if the TIF SCS Forwarding feature is enabled.

5.157.3 Limitations

No limitations are associated with this feature.

5.158 TIF Selective Screening (Release 45.0)

The TIF Selective Screening feature is an enhancement to the existing TIF framework to allow customers to build more advanced filtering rules. The main use is to be able to take formatting actions against the CgPN and CdPN of ISUP messages.

The TIF Selective Screening feature adds SAxDGTS support for NPP SELSCR Service Action and two lists of formatting actions - FASCRCDD, and FASCRCG - to allow formatting of CdPN digits and CgPN digits in ISUP message. These formatting actions are applied when the Called Party Number in the ISUP message passed the TIF Selective Screening process.

FASCRCDD

Formatting action list to format ISUP CdPN digits when the Called Party Number passes TIF Selective Screening process

FASCRCG

Formatting action list to format ISUP CgPN digits when the Called Party Number passes TIF Selective Screening process

SAXDGTS

Generic name for Service Action Data Digit String value parameters (SA1DGTS, SA2DGTS, SA3DGTS, ... SA8DGTS) that store the call types for all of the CdPNs that match the NPP rule containing the SELSCR Service Action

5.158.1 Feature Control Requirements

- FAK for Part Number 893-0402-01
- A temporary FAK cannot be used to enable the feature.
- The feature requires EPAP, and is mutually exclusive with ELAP and the TIF Number Substitution feature.
- The feature can be turned off after it has been turned on.

5.159 TIF Simple Number Substitution (Release 39.2)

The TIF Simple Number Substitution feature uses the [Triggerless ISUP Framework \(Release 39.2\)](#) to replace the calling party in an ISUP IAM message with a configured calling party number from the TIFOPTS table. The RTDB is not used.

5.159.1 Feature Control Requirements

The TIF Simple Number Substitution feature has the following feature control requirements:

- FAK for part number 893-0240-01
- The GTT feature bit must be turned on before the feature can be enabled.
- The Gateway Screening feature bit must be turned on before the feature can be enabled.
- The feature cannot be turned off after it has been turned on.
- A temporary FAK cannot be used to enable the feature.

5.159.2 Hardware Requirements

The TIF Simple Number Substitution feature requires Service Module cards. The feature cannot be enabled if TSM cards running the **sccp** application are provisioned in the system. TSM cards running the **sccp** application cannot be provisioned if the TIF Simple Number Substitution feature is enabled.

5.160 TIF Subscriber CgPN Blacklist (Release 44.0)

The TIF Subscriber CgPN Blacklist feature generates an ISUP RELEASE (ISUP REL) message back to the originator of an incoming IAM message based on the Calling Party Number (CgPN) if one of the following conditions exists:

- The CgPN is found in the RTDB, and the RTDB entry has CgBL flag = YES.

- The CgPN is not found in the RTDB.

Two new CgPN Service Actions are created to support this feature:

- BLRLS-generate an ISUP REL message if the Calling Party Number is found in RTDB and the CgBL flag = YES
- BLNFNDRLS-generate an ISUP REL message if the Calling Party Number is not found in RTDB

5.160.1 Feature Control Requirements

- FAK for Part Number 893-0376-01
- The GTT and Gateway Screening features must be turned on before the TIF Subscriber CgPN Blacklist feature can be enabled.
- If the ELAP feature (Part Number 893-0109-001) is turned on, then the TIF Subscriber CgPN Blacklist feature cannot be enabled.
- If an LNP quantity is turned on, then the feature cannot be enabled.
- If the ANSIGFLEX option is turned on in the `chg-stpopts` command, then the feature cannot be enabled.
- The feature requires EPAP.
- A temporary FAK cannot be used to enable the feature.
- The feature can be turned on and off.

5.160.2 Hardware Requirements

The TIF Subscriber CgPN Blacklist feature requires Service Module cards.

5.161 Time Stamps for rept-stat-trbl Report (Release 31.6)

The `display=timestamp` parameter value has been added to the `rept-stat-trbl` command, to display all alarms with the date and time when the alarm was logged.

Only one parameter value for `display` is allowed in the command at one time. Therefore, timestamps cannot be displayed for just inhibited or active alarms (`display=inhb` and `display=act`).

The `display=timestamp` parameter value of the `rept-stat-trbl` command displays all alarms with the date and time when the alarm was logged.

5.162 Time-Based Inhibit Alarm (Release 35.0)

Description

The Time-Based Inhibit Alarm feature allows alarms at or below a configurable severity to be suppressed on a device for a configurable period. This feature allows only desired alarms to be viewed during testing or other maintenance activities.

Hardware Requirements

The Time-Based Inhibit Alarm feature has no hardware requirements.

Limitations

The Time-Based Inhibit Alarm feature has no associated limitations.

5.163 TINP (Release 38.0)

The Triggerless ISUP Number Portability (**TINP**) feature allows the EAGLE 5 ISS to perform number portability database (**NPDB**) lookup on selected ISUP IAM messages to determine whether a called party number (**CdPN**) is ported. Gateway screening is used to determine which messages receive NPDB lookup. After NPDB lookup is performed, the EAGLE 5 ISS can relay the IAM message or generate a release message to inform the user that the CdPN is ported.

The TINP feature can be used to provision the EAGLE 5 ISS to determine whether the CdPN contains a Home Routing Number (**HOMERN**) and to remove the number if it is located.

The TINP feature co-exists with all EAGLE 5 ISS features requiring EPAP and is mutually exclusive with all EAGLE 5 ISS features requiring ELAP. Turning on the TINP feature overrides the ISUP NP with EPAP feature.

5.163.1 Feature Control Requirements

The TINP feature has the following feature control requirements:

- The GTT and GWS features must be turned on before the TINP feature can be enabled.
- A FAK for part number 893-0189-01
- A temporary FAK cannot be used to enable the feature.
- The feature cannot be turned off after it has been turned on.

5.163.2 Hardware Requirements

The TINP feature requires E5-SM4G cards or DSM cards. The feature cannot be enabled if TSM cards running the **sccp** application are present in the system.

5.163.3 Limitations

The TINP feature has the following limitations:

- The collection of digits from SAM is not supported. If SAM is part of the call setup, it is assumed that the SAM is for international calls which are not ported.
- Outgoing digits that are longer than 21 digits are truncated.
- Splitting of digits between IAM and SAM is not supported.
- If an IAM is relayed to a different network type, then ISUP information is not converted to the new network type.
- IAMs larger than 253 bytes (ANSI/ITU-N24) and 256 (ITU-I/ITU-N14) bytes are not supported.
- If the TINP feature and the ISUP NP with EPAP feature are both enabled, the TINP feature overrides the ISUP NP with EPAP feature.

5.164 TOS Field Marked in Outgoing Packets (Release 46.0)

The TOS Field Marked in Outgoing Packets feature allows setting the TOS (DSCP) field in outgoing packets from EAGLE. With this feature, Table IPOPTS entries are in Table EGLEOPTS.

5.165 Transaction-based GTT Loadsharing (Release 36.0)

Description

The **Transaction-based GTT Loadsharing** feature (**TBGTTLS**) is an enhancement to intermediate and final **Global Title Translation** load-sharing. The **Transaction-based GTT Loadsharing** feature enables **GT**-routed messages that are part of the same transaction to be loadshared to the same destination in a **MAP** group or **MRN** group.

The **Transaction-based GTT Loadsharing** feature uses the transaction parameter to control loadsharing for Class 0 and Class 1 **SCCP** messages. The **Transaction-based GTT Loadsharing** feature also controls loadsharing for unit data (**UDT**) and extended unit data (**XUDT**) messages.

EAGLE 5 ISS generates a unique key for each **MSU** when transaction-based **GTT** loadsharing is performed. This key, called the **MSUKey**, is a unique 4-byte number. The value of the **MSUKey** depends on the selected transaction parameter. The transaction-based **GTT** loadsharing algorithm ensures that message signal units (**MSUs**) that have the same **MSUKey** value are routed to the same destination within the Entity Set.

- For **UDT** messages, the key is based on **MTP**, **SCCP** or **TCAP** transaction parameters
- For **XUDT** messages, the key is based on **MTP** parameters or **SCCP** parameters
- For **TCAP**, the **TCAP ID** is the **MSUKey** value.
- For **SCCP** in **XUDT/XUDTS** and **UDT/UDTS** messages, the last 4 bytes of the **GTA** field of **CdPA** in the inbound **MSU** are the **MSUKey**.
- For **MTP** in **XUDT/XUDTS** and **UDT/UDTS** messages, the last 3 bytes of incoming **OPC** and 1 byte of **SLS** are combined to create a unique **MSUKey**. This structure applies to both **ANSI** and **ITU** point codes. This is the default parameter for performing **TBGTTLS**.

The **EAGLE 5 ISS** provides multiple forms of Intermediate and Final **GTT** loadsharing. These loadsharing modes are determined by the relative cost of each entity in the Entity Set. Of the possible configurations (Solitary, Dominant, Load-Shared, and Combined Load-Shared/Dominant), **TBGTTLS** affects only entities that work in the Load-Shared and Combined Load-Shared/Dominant loadsharing modes.

- In Load-Shared mode, the entire Entity Set is a part of one **RC** group and **MSUs** are load-shared based on the transaction parameter within the entities in the Entity Set. If none of the entities in the Entity Set are available for routing, the message is dropped and a **UDTS/XUDTS** message is generated if “return on error” is set in the **SCCP** message. A **UIM** is generated to notify the user that the **MSU** has been dropped.
- In Combined Load-Shared/Dominant mode, **TBGTTLS** is initially applied to the **RC** group, where the **PC/PC+SSN** belongs that is obtained as a result of **GTT**.
 - If none of the entities are available for routing within that particular **RC** group, the next higher cost **RC** group shall be chosen and **TBGTTLS** is applied to the new **RC**

group. This process is repeated until there is no available entity in the Entity Set for routing.

- If none of the entities are available for routing, the message shall be dropped and a **UDTS/XUDTS** message is generated if “return on error” is set in the **SCCP** message. A **UIM** is generated to notify the user that the **MSU** has been dropped.

A feature access key (**FAK**) for part number 893017101 is required to enable the **Transaction-based GTT Loadsharing** feature.

- The **GTT** feature must be on before **TBGTTLS** can be enabled.
- After the feature is enabled and turned on, it cannot be turned off.
- No temporary **FAK** is allowed for the feature.

Hardware Requirements

The **Transaction-based GTT Loadsharing** feature has the following hardware requirements:

- **DSM** cards
- **TSM** cards that run the **SCCP** application cannot be provisioned if the feature is enabled. The feature cannot be enabled if **TSM** cards that run the **SCCP** application are configured in the system.

Limitations

The **Transaction-based GTT Loadsharing** feature has the following limitations:

- If the Transaction-based Loadsharing and Weighted **GTT** Loadsharing features are both enabled, then transaction-based loadsharing has higher priority. This guarantees that messages of a single transaction are loadshared to the same entity within the **MAP** group or **MRN** group.
- For transaction-based routing, loadsharing can be guaranteed only when incoming messages are well distributed over **MTP/SCCP/TCAP** parameters. When the incoming traffic is well distributed using the **MTP/SCCP/TCAP** parameters, then **EAGLE 5 ISS** will distribute traffic (at least 1,000 messages) in accordance with load sharing applicable to the **MAPSET/MRNSSET** with an allowed deviation of $\pm 5\%$. If a new entry is added or an existing entry is deleted from an **RC** group within a Entity Set while **MSUs** are getting routed to one of the entities in that particular **RC** group, the **EAGLE 5 ISS** might not be able to maintain the load share distribution and allowed deviation for the loadshared traffic.
- When the **Transaction-based GTT Loadsharing** feature and the Weighted **GTT** Loadsharing feature are both on, the following scenario can occur:
 - An **RC** group (for example, **RC1**) becomes prohibited and all of its traffic is rerouted to an alternate **RC** group (for example, **RC2**).
 - A node comes up in **RC1** (which was the initial destination for an **MSU** routed base on **TBGTTLS**), but the weight percentage of **RC1** is still below the in-service weight threshold.
RC1 is still considered prohibited and traffic is not sent to the node in **RC1**.
- If the number of available entities within the **RC** group differs between successive **MSU** transmissions, all the **MSUs** that are getting routed to alternate destination

(because the primary destination was not available) get rerouted, even if the entity that has become unavailable is not the destination entity for those **MSUs**.

- When the Primary **Destination** is inhibited and the traffic is failed over, the node state might not be maintained if other nodes also fail.
- When an entity is added to a group or deleted from a group, so that the number of entities in the group changes, the assignments within the group could all change.

5.166 Translation Type Mapping (Release 21.0)

Certain **SCCP** messages contain a called party address parameter that contains a translation type field. The translation type field indicates the type of global title processing the **EAGLE** must perform. The values used within any particular network may be different than the standardized values that are defined for internetwork applications.

The translation type mapping feature maps standardized internetwork translation type values to intranetwork translation type values used within any particular network. This feature also maps intranetwork translation type values to standardized internetwork translation type values.

The only **SCCP** messages that are affected by translation type mapping are **UDT** and **XUDT** messages, received or transmitted, whose global title indicator is 0010 (**ANSI/ITU**) or 0100 (**ITU**). Other messages that contain the called party address parameter are not affected. For example, **UDTS** messages are assumed to be **MTP** routed and need not be examined. **XUDTS** messages are either **MTP** routed or use one translation type value indicating global title to point code translation and should not be mapped.

The translation type mapping feature is configured for any linkset, however, translation type mapping has no effect on messages in X.25 linksets, since this feature has not been implemented for X.25 linksets. There is currently no specification for translation type mapping in **ITU** networks, therefore, the **EAGLE** provides the same translation type mapping function as for **ANSI** networks.

Translation type mapping is performed on each **LIM** in the linkset. Incoming translation type mapping is performed before global title translation, gateway screening, or the **MSU** copy associated with the **STP LAN** feature. Outgoing translation type mapping is performed after global title translation, gateway screening, and the **MSU** copy associated with the **STP LAN** feature.

When outgoing translation type mapping is provisioned and the **MSU** is copied for the **STP LAN** feature, the copied **MSU** is mapped. This is done because the mapped translation type may have a different meaning in the local network, causing the **MSU** to be interpreted incorrectly.

If the database transport access feature is being used, and the **MSU** encapsulated by the gateway screening redirect function contains a translation type that must be mapped on an incoming basis, the encapsulated **MSU** contains the mapped translation type. The translation type of the new **MSU** is obtained from the gateway screening redirect table.

The **EAGLE** supports 64 translation type mappings for each linkset. This includes both incoming and outgoing translation type mappings. Since the **EAGLE** supports a total of 255 linksets, the total number of translation type mappings that can be provisioned in the **EAGLE** is 16,320.

A new measurement report has been created to report the new daily measurements of the linkset, the `mtcd-linkset` measurement report. Three new measurements are collected and reported.

- **ZTTMAP** — translation type mapping translations performed - The total number of translation type mappings performed by the entire **STP** maintained over 30 minute intervals. This is displayed in the `sysot-stp` report.
- **ZTTMAPI** — translation type mapping translation performed - **MSUs** received on the gateway linkset - The number of incoming translation type mappings performed per linkset over 30 minute and daily intervals. These are displayed in the `comp-lnkset` report every 30 minutes and the daily `mtcd-lnkset` report.
- **ZTTMAPO** — translation type mapping translation performed - **MSUs** transmitted on the gateway link set - The number of outgoing translation type mappings performed per linkset over 30 minute and daily intervals. These measurements are displayed in the `comp-lnkset` report every 30 minutes and the daily `mtcd-lnkset` report.

5.167 Triggerless ISUP Framework (Release 39.2)

The Triggerless ISUP Framework (**TIF**) provides an overall structure for various features that allow the EAGLE 5 ISS to intercept and process ISUP messages that would normally be thru-switched.

Note:

At least one of the TIF features must be turned on before the TIF capabilities are available.

Existing Gateway Screening rules are used to separate ISUP traffic and forward the appropriate MSUs to the TIF for processing. The TIF decodes the MSU, invokes the Numbering Plan Processor (NPP) on Service Module cards, and encodes the results. TIF features provide Service Actions (**SAs**) to the NPP. These SAs provide database access, data evaluation, and special handling for the MSU.

The TIF introduces a TIFOPTS table.

Note:

Only customers that had TINP enabled prior to upgrade to Release 39.2 will be able to access both the TINPOPTS and TIFOPTS tables and use the TINP feature after the upgrade occurs. All other customers will only be able to access the TIFOPTS table after the upgrade occurs.

5.167.1 Feature Control Requirements

The TIF has the following feature control requirements:

- The GTT feature bit must be turned on before any TIF feature can be enabled.
- The Gateway Screening feature bit must be turned on before any TIF feature can be enabled.
- At least one TIF feature must be enabled before the TIFOPTS table can be provisioned.

- The associated feature must be enabled before the desired SA can be enabled.
- The **tif**, **tif2**, or **tif3** service must be turned on before the run-time behavior for any TIF feature can execute.

5.167.2 Hardware Requirements

The TIF and all TIF features require Service Module cards. The TIF is not supported on TSM cards running the **sccp** application. TSM cards running the **sccp** application cannot be provisioned if a TIF feature is enabled.

5.168 Triggerless LNP (Release 24.0)

The **Triggerless LNP** feature provides service providers a method to route calls to ported numbers without having to upgrade their signaling switch (end office or mobile switching center) software. In a trigger-based **LNP** solution, the service providers have to modify the end office (**EO**) or mobile switching center (**MSC**) to contain the **LNP** triggers. These triggers cause the **EO/MS**C to launch the query to the **LNP** database and route the call based on the returned location routing number (**LRN**).

Refer to the **Database Administration Manual - LNP** for current configuration information on this feature.

5.169 TSM Warm Restart and Incremental Loading (Release 26.0)

Overview

In prior releases, when a **TSM/BLM** card running the **SCCP/EBDABLM GPL** boots unexpectedly or is manually booted (i.e. init-card), the **GPL** and the database on the card are reloaded from the **OAM**. The reload time is significantly affected by the **LNP** database size, which requires approximately 5 minutes for every one million ported numbers.

However, a complete LNP data reload may not be required if the LNP database on the card is coherent at the time of the reset. If no LNP updates occur from the time the TSM/BLM goes off-bus to the time comes back on the bus, the LNP database on the card is the same as the LNP database on the OAM.

In the event LNP updates occur while the TSM card is not in service, the Incremental Loading feature tracks the updates, and applies them to the card when it is ready.

In either case, a complete data reload may be unnecessary if the on-card LNP database is at or near the same level as the OAM LNP database. Warm restart bypasses data loading of the LNP database only. GPL and non-LNP table data/dynamic data loading is unaffected. Incremental loading applies only to LNP updates, non-LNP database updates are not supported.

Warm Restart

The Warm Restart feature modifies the default EAGLE operation to preserve the LNP database during a TSM/BLM card reset provided the requirements for performing a warm restart are met (see the following table). Those requirements are that:

- power to the card is uninterrupted

- card level checks determine a warm restart is allowed
- card database level is the same as the **OAM** database level or can be incrementally loaded to the current level
- **LNP** audit is **ON** and has run at least once (otherwise all **LNP** checksums on the **OAM** are unknown)
- card database is coherent at the time of reset and the **LNP** database audit during card initialization passes

Table 5-27 Conditions for Performing Warm Restart

Condition	Description
POWER ON	Power on reset (card is pulled and reinserted).
XILINX VERSION	M256 Xilinx program version has changed from previous version.
DB VERSION	LNP Database version has changed from previous version. On-line Memory allocation (alloc-mem), import or bulk downloads (chg-db), or changes from release to release may alter the DB version.
DB LEVEL	DB level not supported or difference exceeds incremental loading capability. Caused by reset of OAMs or if the number of updates exceeds the incremental loading capability.
DB STATUS	DB status of the card is incoherent at the time of a reset. Can be caused by a failed network card update or a reset during a database update to the card.
HW ERROR	Hardware error bit checks on the card fail during card initialization.
AUDIT FAILED	Checksum comparisons of the LNP database fail during card initialization. Data on the card is determined to be corrupted after the reset (was not yet detected by normal auditing).
AUDIT TIMEOUT	LNP initialization audit timed out (SW failure).
NO AUDIT	Unable to perform LNP audit. LNP audit not on (LNP Options has AUDIT=OFF. Or, the rate of LNP updates exceeds LNP audit's ability to compute checksums (excessive unknown checksums). This is more likely on a small database where there are fewer checksums. The percentage of known checksums must be 99% or more. The percentage is based on the number of checksums in use, which is smaller for small databases (such as 2 MIL TNs or less).
USER REQUEST	User initiated <code>init-card</code> or <code>init-sys</code> command reload type cold. The default restart type for these commands is a cold or full LNP data reload. User must specify <code>data=persist</code> for warm restart on command.
UNKNOWN / OTHER	Unknown or other type of software failure.

Incremental Loading

The Incremental Loading/Warm Restart feature modifies the reload procedure for an LNP database card (i.e. TSM). The LNP database will remain persistent as long as power is not removed from the card. In the event of a card reload, the TSM will check to see if an LNP database full reload is required. If a full reload is required, the OAM will be allowed to continue to process LNP updates from the LSMS to the other TSM

cards. The OAM will track the database changes required for the reloading TSM card and apply those updates when the TSM is ready to be placed back in service.

This circumvents the need to inhibit LNP updates in most cases. The requirements to perform these operations are:

- A database level and restart type indication from the restarting card can be accepted and processed.
- **Card** requests for both warm and cold restarts can be processed.
- Changes in the OAM LNP database can be tracked and applied on an "as needed" basis per reloading card.
- DB operations (e.g., init card with DATA = PERSIST/REFRESH) can be processed properly.
- OAM can temporarily inhibit LNP updates for a small period of time in order to complete the loading process when necessary with out losing EOAP/OAP status or Q.3 association with the LSMS.
- Incremental loading will support up to 25 TSM cards and 1 BLM card for incremental loading purposes.

Maintenance

The following sections describe the maintenance changes required as part of the Warm Restart and Incremental Loading features.

Loading Process

The loading process involves the continuous tracking of LNP database changes and applying those changes to cards that are coming into service. Changes to the LNP database occur each time that an LNP transaction takes place. A single LNP transaction (i.e., change) can affect multiple LNP tables. Each LNP transaction generates a new level within the same version of the LNP database (see). In other words, each LNP database version can go through a number of levels (changes).

Figure 5-30 Database Levels

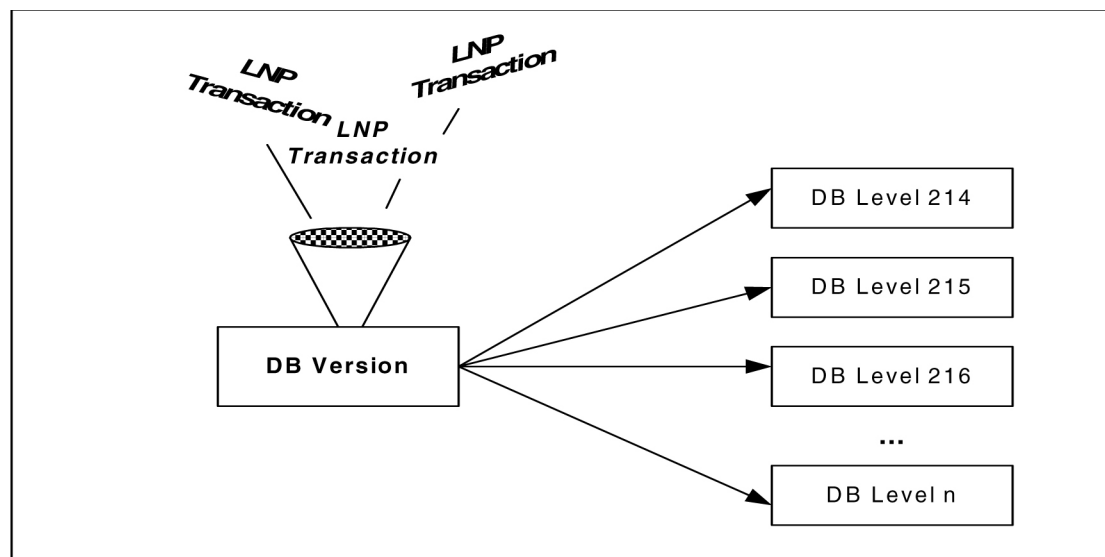

Applying the LNP data to the card(s) may be done either incrementally or as a full database restoration: cards at the same LNP database version but at different database levels can be incrementally loaded while cards at a different LNP database version must receive a full database download.

In order to track LNP database changes for incremental loading, a table of database levels and modified memory pages will be maintained by OAM. This will allow cards at varying database levels to be incrementally downloaded with a subset of the entire database. As the data changes in time, the changes are to be tracked and then applied to the appropriate cards that are in an active load list. Note that all cards appearing within a particular load list will receive the same dataset.

The following subsections discuss the approaches for delivering the LNP data to the appropriate cards and for tracking LNP database alterations.

Card Loading For Warm Restarts

System loading for the SCCP/EBDABLM GPL at the TSM/BLM card will be modified to determine whether to perform a warm or cold restart. The following figure depicts the SCCP/EBDABLM on-card decision making process for this feature.

Figure 5-31 On-Card Warm Restart Decision Flow

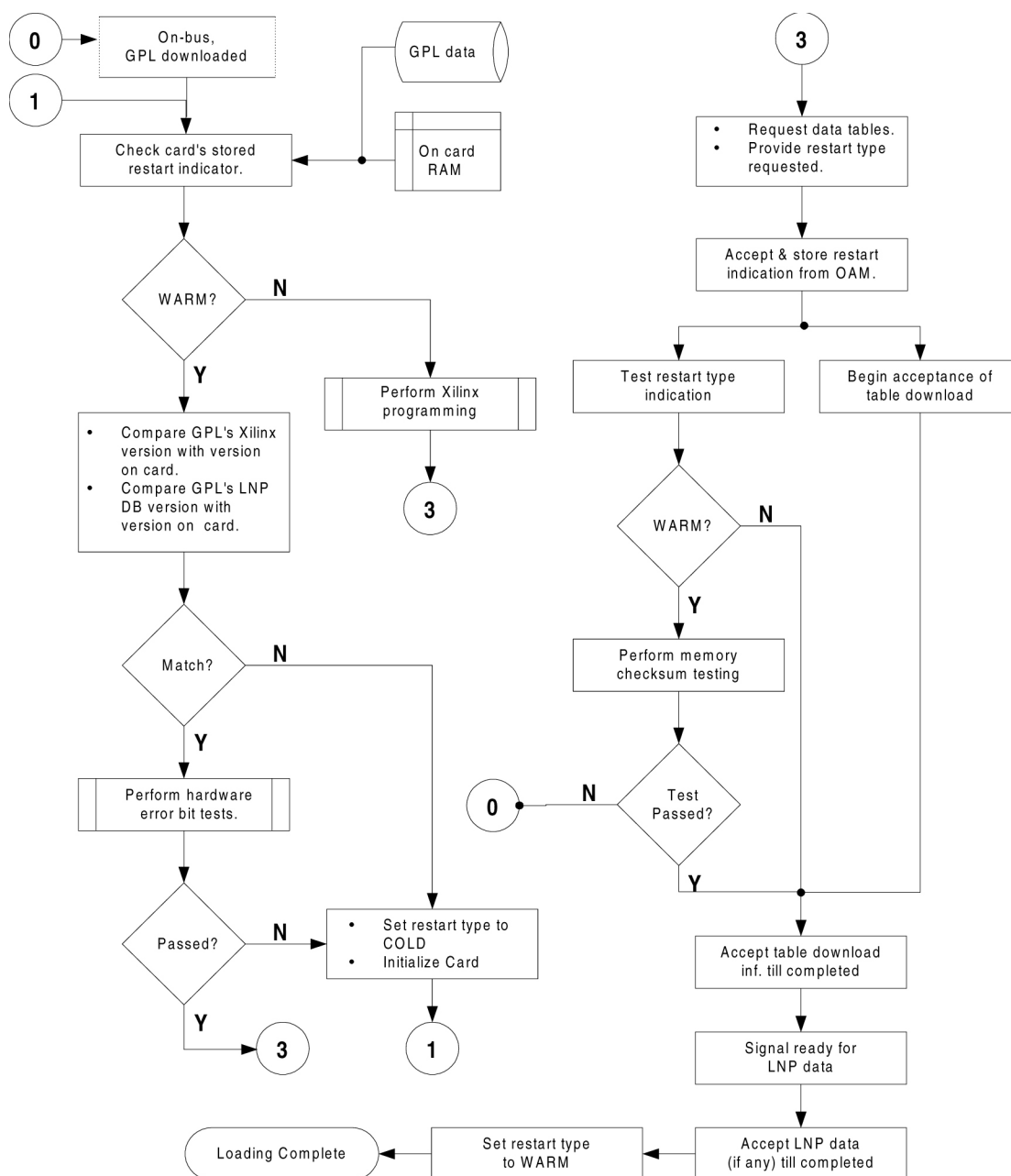

The figure shows that the check for the stored restart type is performed first. The restart type value shall always be warm by default. This value can be set to cold by either an indication to the card from the user (i.e., a forced cold restart) or by the card when some error condition occurred (e.g., LNP database versions did not match). The warm restart type may also be changed at some point during the restart process.

For example, the OAM may determine that the request for a warm restart cannot be honored and deliver an indication for a cold restart (i.e., a full LNP download).

The decision process involves several checks to verify eligibility for a warm restart request. If all of the criteria are met, the request for a warm restart is made. In order to minimize delays

in the download process, the **SCCP/EBDABLM GPLs** shall perform the memory checksum tests in parallel with the data table loading whenever a warm restart is in progress.

Once the non-LNP tables have been loaded and the checksum tests have passed, an indication of the card's readiness to receive LNP data will be raised. At this point, **OAM** will begin delivery of the LNP tables followed by a new checksum table.

The OAM must be in agreement (i.e., there is no cause to override the request), then the warm restart is performed and an incremental download of the LNP database is carried out if required. The criteria for OAM to be in agreement are as follow:

- The cards reported database level is not greater than the OAMs current database level.
- The cards reported database level must be in the DB Level Transition List (card can be incrementally loaded).
- There are approximately 99% known LNP AUDIT checksums (sufficient to perform on card audit).

SCCP/EBDABLM GPL Impacts

The SCCP and EBDABLM GPLs will be modified to incorporate the decision making ability with regards to the type of restart needed (see figure). Specifically, the decision to request a warm restart will be made if:

- **M256** Xilinx is programmed and the bit file has not changed.
- **LNP** database version has not changed.
- Hardware error bit checks on the card do not fail.
- **Checksum** comparisons of the **LNP** database do not fail. Each applicable card shall be able to compare the **LNP** database on the card to the **LNP** database on the **OAM**.
- `init-card` or `init-sys` command with a reload type of **COLD** was not requested.

The **SCCP** and **EBDABLM GPLs**, operating on the **TSM/BLM** cards respectively, shall be capable of storing, retrieving, and reporting pertinent information for the restart decision process using non-volatile memory.

The software will maintain, at a fixed memory location, the:

- Xilinx program changed indication.
- **LNP** database version.
- **LNP** checksum table.
- Restart request type (warm, cold).

The initialization sequence of the application software must not reprogram the **M256** Xilinx. The **M256** Xilinx is unable to maintain **DRAM** data integrity during the reprogramming process. The Xilinx shall be reprogrammed only if a cold restart is to be performed. In addition, if the Xilinx is already programmed and the version has not changed, the **DRAM** check bit initialization shall be bypassed.

An **LNP** checksum table is downloaded by the **OAM** at the end of the download process. This table will be preserved in memory and used to verify the **LNP** database during the next restart operation.

When a warm restart is requested and agreed upon by **OAM**, an incremental loading of the **LNP** database will be performed if required. Should a cold restart be requested or a warm restart request be overridden by **OAM**, a full **LNP** database download will be performed.

OAM Impacts

In order for the **SCCP/EBDABLM** restart type request to be processed during card loading, the **OAM GPL** will require modifications. The changes will involve:

- All information necessary for the card to determine if it can perform a warm restart will be delivered in the initial download to the card.
- Reacting to a specific restart request type from an authorized card.
- Tracking changes to the **LNP** database will occur at all times.
- Possibly performing an early card deletion from load list for warm restart if a different restart type is required.
- Downloading the **LNP** checksum table at the end of the loading process.
- **LNP** Audit checksum table and incremental load list is cleared upon an import or restore.

The **SCCP/EBDABLM GPL** will report its current database level to **OAM** (see [Figure 5-30](#) and [Figure 5-31](#)). The **OAM** must verify that the database level has not incremented beyond an acceptable point for incremental loading. The restart type may be overridden by the **OAM** and an indication of such will be delivered back to the restarting card in the form of all **LNP** database data being delivered.

In addition, if a cold restart is required and the card cannot be incrementally loaded, **LNP** updates and **LNP** audits must be ignored by the affected card.

Tracking LNP Changes for Incremental Loading

In order to provide an incremental download of **LNP** data, modifications to the database must be tracked. The database change engine (**DBCD**) will write the modified table ids and record entry numbers into a table as changes occur.

Figure 5-32 LNP Data Tracking and Loading Overview

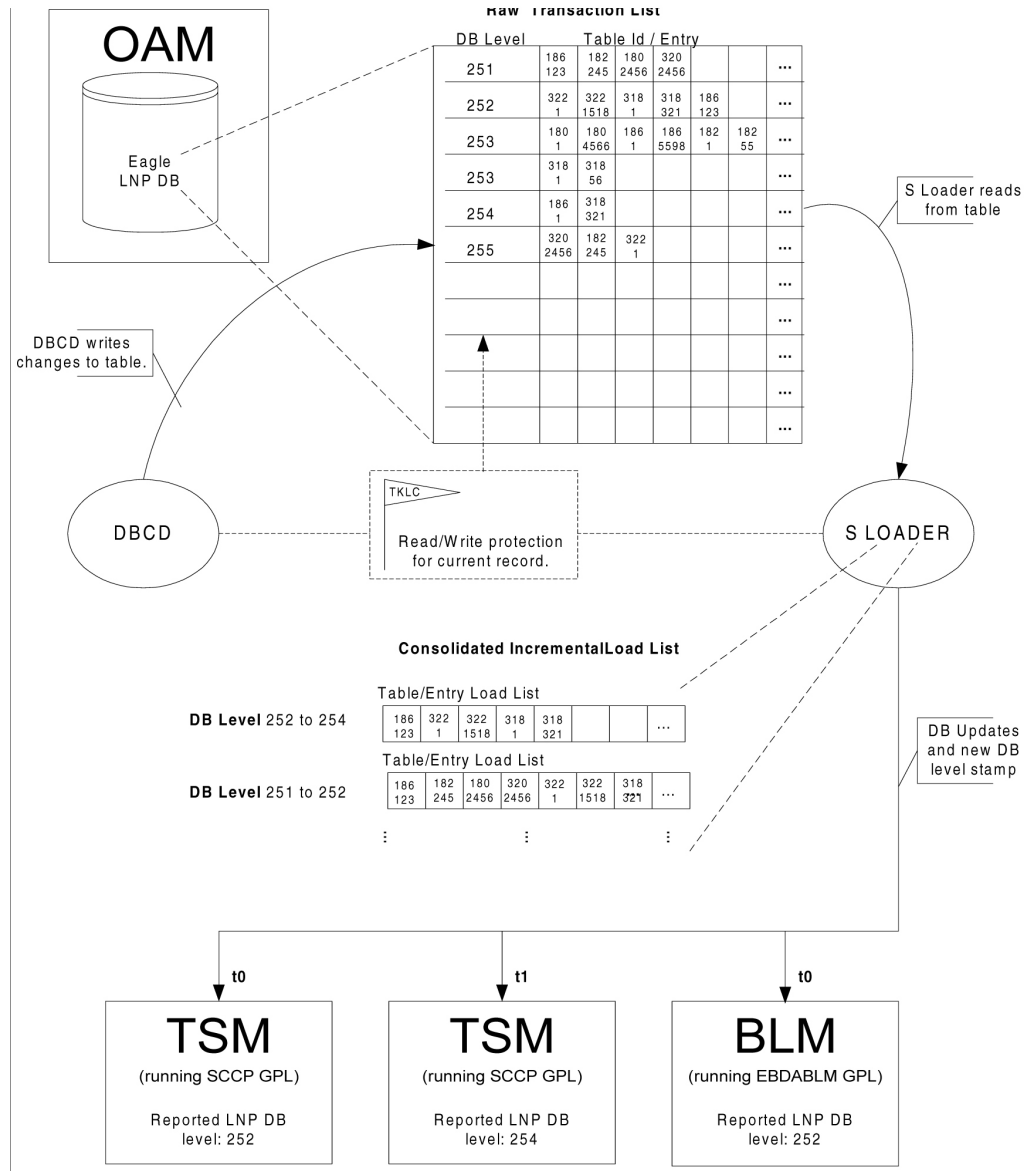

Each **LNP** database change generates a new database level. The new level shall become the current level and all level entities associated with the **LNP** transaction will be indicated with the same database level table entry. The table shall be circular so that changes can be tracked and applied to the cards in a continuous manner.

If the number of entities is exceeded within a database level record, the record will be marked as continued and the next entry will contain the same database level, thus extending the database level record entry.

System Loader will read the database transition to determine which entities are to be downloaded to a particular card based upon its reported database level. A protective mechanism shall be used to prevent the System Loader task from reading a record while it is being written to.

System Loader shall create card load lists and associate the database level entities that must be downloaded based upon database levels. Each time period (i.e., an iteration in time, t_0 , t_1 , etc., where $t_n = t_n - t_{n-1}$) will represent some number of database levels: the set of changes that occurred within a given time period. System Loader shall have one list that is the "active list". The active list will represent the cards that are currently receiving **LNP** data. System Loader shall also maintain additional lists of cards that are waiting for an **LNP** data download at other **DB** levels (see [Figure 5-32](#)). Once a list becomes the active list, no new entries shall be made. Any cards requesting **LNP** data would have to be placed into a new/other list.

Cards will be assigned to a particular load list based upon their reported database level as well as the time of their request for **LNP** data. Thus, a card reporting a level of 259, for example, may be placed in a list being formed for level 257 in order to grant its request for data without delay. While this methodology would download data that is not needed by some cards within the group, it prevents cards from waiting for a new list to be formed and takes into account that there is a finite number of lists available.

When Incremental Loading detects that a small amount of time is needed to complete a **TSM/BLM** download to reach the current **DB** Level then Incremental Loading will automatically inhibit **LNP** updates for the time needed to complete the download. Thereby avoiding continuous circular incremental loading of sustained 2TN modifications.

LNP Audit

In order to guarantee the integrity of the **LNP** database, the **TSM/BLM** cards shall perform an audit of their **LNP** database during a warm restart. To achieve this the following changes to the **LNP** audit process on the **OAM** and **TSM/BLM** cards are required:

- **TSM/BLM** cards shall be capable of ignoring **RADB LNP** update and **LNP** audit messages during data loading.
- **LNP** checksum table shall be downloaded to all **TSM/BLM** cards during data loading.
- **LNP** audit's checksum table shall be maintained on the **OAM** and **TSM/BLM** cards.

A warm restart is allowed only if **LNP** audit has completed an audit of the current database at least once and the **LNP** checksums are approximately 99% known.

LNP AUDIT considers each of the **LNP** database tables to be segmented into "pages" where a page is defined as the number of table records that can be read into a 32KB buffer using a single disk operation. A "dirty page" is a page that has recently been modified during a database update for which the associated **LNP** audit checksum is unknown.

During card initialization **LNP** audit shall checksum the **LNP** database and compare against the **LNP** checksum table maintained on the **TSM/BLM** card. As a result, the **LNP** checksum table must be downloaded to all **TSM/BLM** cards during data loading and must be maintained on the **TSM/BLM** cards during database updates and audit queries.

Currently the checksum table is not loaded to the cards. When a **LNP** database update occurs the checksums on the card will be set unknown for any dirty pages. When a dirty page is audited the **LNP** checksum table on the card is updated accordingly by storing the recalculated checksum in the table. During data loading **LNP** updates and audit notifications shall be ignored at the card: currently a **LNP** update during loading would reset the **TSM/BLM** card.

During the warm restart process dirty pages will not be audited, as the checksums for the dirty pages are unknown. The **LNP** checksums must be approximately 99% known or a warm restart is not permitted (currently a maximum of 250 dirty pages). This initial audit to determine if a warm restart is allowed is performed using the current **LNP** checksum table in the card's persistent database.

If the checksum compare fails a card reset and full **GTT** and **LNP** data reload shall be performed. No application trouble or obituaries will result; the card will simply restart the loading process. The existing **LNP** audit process currently generates 1 checksum calculation every 1.36 seconds. Typically, **LNP** updates will dirty the same page(s) as previous updates and thus require significantly fewer writes to disk when collected over multiple updates.

LNP audit does not audit recently changed dirty pages, thus allowing them to be collected over multiple updates. Performance measurements of the existing **LNP** audit showed on average 5 or fewer unknown checksums (total) for typical sequential updates during 2 **TN**/sec operation.

If an incremental load to the card is required during a warm restart, the incremental load will complete and then a final audit shall be performed prior to data load complete and going **IS-NR**. This final audit includes pages dirtied prior to the reset only (checksum is unknown in the persistent **LNP** checksum table prior to the download of the new **LNP** checksum table).

A cold restart will result in no pages being audited following the incremental load. Should this final checksum compare fail, indicating that the warm restart failed, a full **LNP** data reload shall be attempted.

The **LNP** checksum table shall be reloaded to the cards only after incremental loading is complete and **LNP** updates have been inhibited. The cards will then complete the audit process for all dirty pages not initially audited during the warm restart verification.

The **LNP** download and audit timeline for a warm restart is depicted in [Figure 5-30](#) and [Figure 5-31](#).

Hardware Requirements

The Warm Restart and Incremental Loading functions require existing **EAGLE** hardware; no new or additional hardware is required for these features. All modifications are at the software level.

- **TSM (SCCP)** card
- **BLM (EBD&A)** card.
- **MCAP (OAM)** card.

The **TSM/BLM** cards must be equipped with enough daughterboard memory to load the entire **LNP** database. The daughterboard requirements for the **EBD&A BLM** card are exactly the same as the memory requirements for a **TSM** card running the **SCCP** application.

Upgrade Considerations

Warm restart shall be supported following upgrade to release 26.0. Warm restart shall not be supported during Release 26.0 upgrade. The warm restart feature provides new functionality at the card level for maintaining over a reset the database level, status, checksum, and other information, which is required to determine if a warm restart should be allowed. Without this functionality the integrity of the **LNP** database cannot be verified. As a result warm restart cannot be supported during the initial upgrade to Release 26.0.

Subsequent upgrades will have the capability to perform a warm restart of **TSM/BLM** cards provided the warm restart conditions as outlined by this document are met. Additional conditions imposed on a warm restart would include:

- card-level capability for converting the existing **LNP** database if the upgrade requires any **LNP** table conversions.
- ability to download new **LNP** tables during a warm restart which are not defined in the source release database on the card.

Currently, new feature development that requires table conversions is written only for the **OAM** database and the data is loaded to the cards following conversion. In order to perform a warm restart during an upgrade requiring **LNP** table conversions, the conversion functions must also be written for the **TSM/BLM** cards. If the **LNP** database version does not change and no table conversions are required, upgrades after release 26.0 will be capable of warm restart provided the network conversion utilizes the `data=persist` parameter when initializing **TSM/BLM** cards.

Dependencies

The warm restart and incremental loading features must be implemented together for a complete solution to exist. These features have no other dependencies.

Limitations/Restrictions

1. **LNP** audit must be **ON** and have run at least once to completion. If **LNP** audit is not turned on, all **LNP** checksums on the **OAM** are set to unknown. A warm restart is allowed only if **LNP** audit has completed an audit of the current database at least once and the **LNP** checksums are approximately 99% known. Without the **LNP** checksums in a known state, the database on the **TSM/BLM** cards cannot be verified following the reset. Warm restart may not be allowed if a worse-case 2 **TNs** is maintained.

Sustained 2 **TNs** on a small database will prevent a warm restart. Fewer checksums are in use for a small database. As a result, an update will make a greater percentage of the in-use checksums unknown. Thus the percentage known of the checksums depends on the size of the database.

2. Non-**LNP** database provisioning which affects the **TSM/BLM** cards (such as **GTT** updates to the **TSM** cards or alloc-mem 4 digit object updates to all **TSM/BLM** cards) during loading may result in a card reset. Unlike the continuous stream of **LNP** updates automatically applied to the **EAGLE** from the **LSMS**, non-**LNP** updates are controllable by the customer. The customer must decide whether to suspend these updates during **TSM/BLM** loading based on minimum service and their current priorities.

If the update being applied affects tables already loaded, the card will not reset (i.e. the database class of the update was already loaded by the card).

3. **Card** loading, including Incremental Loading, is inhibited while the import and restore operations are in progress.
4. **Database** btree rotations will limit the time tracking capabilities by causing excessive database level entities and multiple database level records to be stored for a single database level.

5.170 TT Independence for LNP Queries (EAGLE Release 30.0/IP7 Secure Gateway Release 8.0)

Description

Currently, the translation type in the query message is used to determine the type of **LNP** query (**AIN**, **IN**, **WNP**) for correct decoding and response formulation. **LNP** queries between

networks are defined to use **TT=11**, regardless of the protocol used. Also, there are other cases where the **TT** alone may not be enough to determine the type of protocol being used, thus making it impossible to correctly decode all queries. Refer to [Figure 5-27](#).

Figure 5-33 Inter-Network Support for LNP Queries

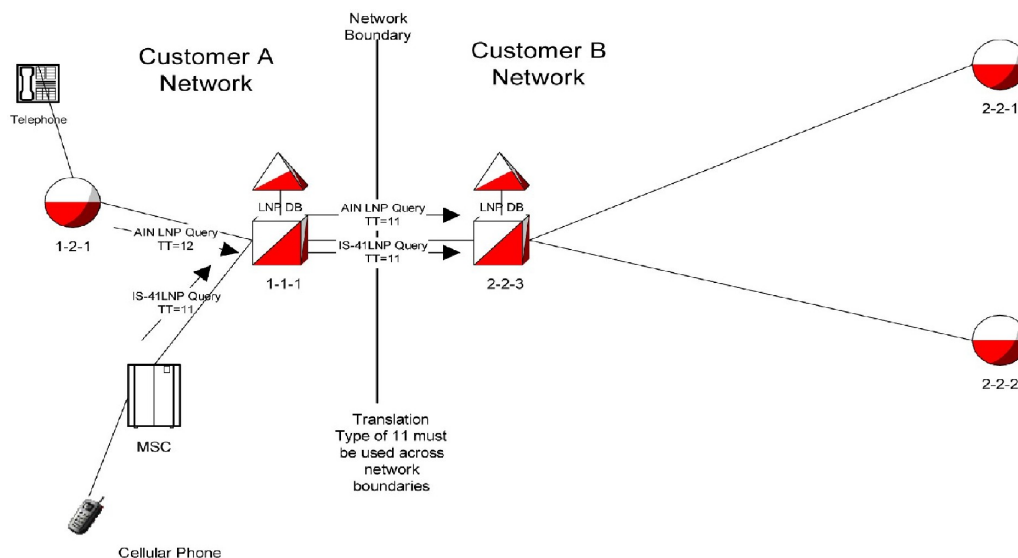

In this example, Network B would not be able to differentiate between the two types of **LNP** queries received from Network A.

The **TT Independence for LNP Queries** feature addresses this issue by providing a new method of protocol determination of an incoming query.

With the **TT Independence for LNP Queries** feature, the **LNP** subsystem will be able to determine the protocol of the query based on other fields in the **SS7** message, rather than relying on the **TT** value. This allows the same translation type to be used for multiple protocols. It allows a query between two networks to be properly handled. (All **LNP** queries between networks are defined to be **TT 11**.)

Hardware Requirements

No new hardware is needed to support this feature.

Upgrade Considerations

While this feature does not affect the upgrade process, note that all **SCCP** cards must be upgraded to the release that contains the **TT Independence for LNP Queries** feature, prior to provisioning the **LNPQS** service.

Limitations

With the implementation of **TT Independence**, **PLNP** Queries with **TT** associated with **LNPQS** will be processed and pegged as **IN LNP** Queries.

Despite the fact that the legacy **EAGLE**'s interface allows the provisioning of the **LNP NPANXX** table's Default Translation (**MRGT**) using the command `ent-lnp-npanxx`,

this should not be done for **LNP** services. Thus, **EAGLE** will *not* use the **NPANXX** Default Translation for **LNP** Queries, even if this data is provisioned.

5.171 TUP Message Type Screening (Release 31.6)

Telephone User Part (**TUP**) protocol is a predecessor to **Integrated Services Digital Network (ISDN) User Part (ISUP)** that remains in use for some market areas. **ISUP** and **TUP** share the same screen function table. **TUP** is supported for **Gateway Screening (GWS)** by overloading the **ISUP** screening table. To use **TUP** screening, the screen set defines the screening order to have an **SIO** table with the rule **SI=4** for **TUP** to screen the **TUP** messages. This **SIO** screening reference is specified in the `ent-scr-isup` command as the next screening reference (`nsr`) value in a screening reference for **TUP** message types.

Point Code screening of **DPC** and **BLKDPC** can be used with the overload of the **ISUP** screen function with **TUP**, as long as an **SIO** screen comes first. To do this there should be an **SIO** rule for **SI=4** to screen for **TUP** protocol and another rule with **SI=5** for **ISUP** protocol, these two rules must also have separate Next Screen Functions. This allows the screening rules after the **SIO** to have two separate streams, one that ends with true **ISUP**, the other that ends with **TUP** overloading **ISUP**.

To use **TUP** screening, the screen set defines the screening order to have an **SIO** table with the rule **SI=4** for screening the **TUP** messages.

Limitations

- **Point Code** screening of **DPC** and **BLKDPC** can be used with the overload of the **ISUP** screen function with **TUP**, as long as an **SIO** screen comes first. To do this there must be an **SIO** rule for `si=4` to screen for **TUP** protocol and another rule with `si=5` for **ISUP** protocol. These two rules must also have separate Next Screen functions. This allows the screening rules after the **SIO** to have two separate streams, one that ends with true **ISUP** and the other that ends with **TUP** overloading **ISUP** in the screening table.
- For the Support **TUP** Message Type Screening feature, the **LSONISMT ISUP** and **TUP** messages are pegged by message type only. There is potential for overlap because **TUP** and **ISUP** share a common message type value and the screens are set up to screen this value. Therefore there is no way to know whether the message was **ISUP** or **TUP** from a measurements point of view. The **UIMs** generated include the **SIO** value, but measurement reports do not.
- For the Support **TUP** Message Type Screening feature, the potential for overlap of message type values for **ISUP** and **TUP** also applies to the screening function. Care must be given to provision the screenset order with **SIO** screen rules to separate **SI=4** (for **TUP**) and **SI=5** (for **ISUP**) prior to the **ISUP** screening function. Although the `-scr-isup` commands support the two separate parameters `isupmt` and `tupmt`, the parameters are handled by the database as the common generic parameter named `isupmt`.

5.172 Two-Point IPLIMx (EAGLE 27.1, IP⁷ Release 2.2)

Two-point **IPLIMx** allows a single **DCM** card loaded with the `iplim` application or the `iplimi` application to support two point-to-point links. In previous releases, each point-to-point link required a separate **DCM** card.

Two sockets can be provisioned for each **DCM** card that runs an `iplim` application or `iplimi` application. One socket is associated with the A port and one with the B port. In this

case, a port is a signaling link. Both sockets use the same physical interface connection and the same **IP** address.

Refer to the **Database Administration Manual - SS7** for current information on this feature.

5.173 Unmate IP Security for Terminal and Measurements (Release 45.0)

The Unmate IP Security for Terminal and Measurements feature provides the capability to unmate the IP security for Telnet and FTP. This is a core enhancement to the OAM IP Security feature. Enabling OAM IP Security requires two steps: process. The first step is to turn ON the OAM IP Security feature. The second step will be enabling security options for a specific network interface (Telnet or FTP).

With the Unmate IP Security for Terminal and Measurements feature, the following combinations are allowed for the well-known ports when OAM IP Security feature is on.

- Neither SSH nor SFTP - allows Telnet and FTP access
- SSH only - allows SSH and FTP access. Telnet and SFTP access are blocked.
- SFTP only - allows Telnet and SFTP access. SSH and FTP access are blocked
- Both SSH and SFTP - allows both SSH and SFTP access. Telnet and FTP access are blocked.

The Terminal security (SSH) is controlled by a new `terminal` option in the Security Default table. This option can be set to ON to enable SSH or set to OFF to disable SSH.

5.174 Unregistered Routing Key Treatment (IP⁷ Release 3.0)

Unregistered **Routing Key** Treatment (**URKT**) provides options for routing misdirected **ISUP** messages, as well as options for routing other signaling information types such as **SCCP** and **TUP**. New Partial and Default routing key types have been introduced to improve the treatment of unregistered routing keys. Supported Partial keys include: **DPC+SI+OPC** for **CIC** traffic, **DPC+SI** for **CIC** and **SCCP** traffic, **DPC** only, and **SI** only for **CIC**, **SCCP**, and **MTP3-Other** traffic.

Each Partial and Default routing key is associated with a socket, or a list of sockets.

A hierarchy of lookups occurs for each **MSU** that does not match a full entry in the routing key table. [Table 5-28](#) clarifies how a hierarchical lookup that attempts to deliver each **MSU** to the best location is performed. Before the lookups can begin, the type of **MSU** must be determined based on the following:

- Type of **MSU** equals **CIC** when the **MSU** has an **SI** value of 5, 13 (**ANSI** and **ITU**) or 4 (**ITU** only).
- Type of **MSU** equals **SCCP** when the **MSU** has an **SI** value of 3 (**ANSI** and **ITU**).
- Type of **MSU** equals Other **SI** for all other **MSUs**.

Table 5-28 Unregistered Routing Key Hierarchy

MSU Type	Lookup Order	Portion of MSU that Must Match Routing Key	Full/Partial/Default
CIC	1	DPC + SI + OPC + CIC	Full
	2	DPC + SI + OPC (<i>ignore CIC</i>)	Partial
	3	DPC + SI (<i>ignore OPC & CIC</i>)	Partial
	4	DPC (<i>ignore SI, OPC & CIC</i>)	Partial
	5	SI (<i>ignore DPC & OPC & CIC</i>)	Partial
	6	None	Default
SCCP	1	DPC + SI + SSN	Full
	2	DPC + SI (<i>ignore SSN</i>)	Partial
	3	DPC (<i>ignore SI, OPC & CIC</i>)	Partial
	4	SI (<i>ignore DPC & SSN</i>)	Partial
	5	None	Default
OtherSI	1	DPC + SI	Full
	2	DPC (<i>ignore SI</i>)	Partial
	2	SI (<i>ignore DPC</i>)	Partial
	3	None	Default

The hierarchy is intended to guarantee that the **MSU** is delivered to the best possible location, based on closest match to the **MSU** content. An **MSU** that does not match a routing key is discarded.

5.175 Update Validation (Release 34.0)

Description

The Update Validation feature provides additional data validation checks prior to applying an update or change from the **RTDB** at the **EPAP** or **ELAP** to the **RTDB** on the **DSM** cards. These additional checks are designed to prevent overwriting of existing data records with new data records when operators are provisioning new subscribers.

Hardware

No new hardware is required for this feature.

5.176 Upgrade Procedure Enhancements (Release 22.0)

With release 22.0, current **EAGLE** users of release 20.0 can be upgraded directly to release 22.0 without having to be upgraded to release 21.0 or release 21.1. Users of Release 21.0 and 21.1 can be upgraded directly to Release 22.0.

The upgrade procedure is executed in two parts.

- **Database and GPL Upgrade** — the current databases are converted to the release 22.0 format and the **GPLs** are upgraded with the release 22.0 **GPLs**.
- **Network Upgrade** — distributes the upgraded **GPLs** through out the system and distributes the converted databases to the upgraded **GPLs**.

The upgrade procedure uses the `act-upgrade` command and, if upgrading from a release 20.0 system, the `init-network` command. The upgrade procedure also uses these items.

- A removable cartridge containing the release 22.0 software.
- A removable cartridge containing the software of the current release (20.0, 21.0, or 21.1).
- A spare **TDM** containing the current databases for the current release (20.0, 21.0, or 21.1).

The `act-upgrade` command converts the current, release 20.0, 21.0, or 21.1, database on the active **MASP** to a release 22.0 database and controls the **MASPs** during the upgrade process.

The `act-upgrade` command has only one parameter, `action`, which details the type of upgrade action to be performed. The `action` parameter has three values, `converttoam`, `oamcomplete` and `dbstatus`.

The `action=converttoam` parameter converts the databases on both the active and standby **MASPs**.

The `action=oamcomplete` parameter sets the upgrade phase to phase 3, sets the database to coherent on the active and standby fixed disks, and places the **SEAS** terminal ports back in service.

The `action=dbstatus` parameter displays the status of all the database partitions on both the active and standby **MASPs**. The output is identical to the output of the `rept-stat-db:display=version` command.

No Reportable Downtime on Network Restart

Release 22.0 provides for network restarts of the **EAGLE STP**, using the `init-network` command, that require less than 30 seconds of nodal isolation and thus do not require reporting of any **STP** downtime (**GR-929-CORE**, section 3.1.1, page 3-3). This enhancement prevents reportable downtime for both network restarts due to unusual conditions and for network restarts during in-service upgrades.

Network restart is the procedure that allows all non-**MASP** cards to be rebooted and restored to service in an orderly and controlled fashion with the intent to minimize network nodal isolation time, the time during which an **EAGLE STP** is unable to communicate to another node in the network (no signaling links are aligned).

Currently, if an **EAGLE STP LIM** running the **SS7ANSI** application is rebooted, it takes approximately 42 seconds to reload the card, align the signaling link, and restart traffic on that signaling link. Thus, with the goal to minimize network nodal isolation to be less than 15 seconds during in-service network upgrades and abnormal conditions requiring network restarts, the network restart process initiated by the `init-network` command will be as follows:

1. Before the network restart process can be started, the **MASPs** must be in one of two possible states, either the **GPL** status of the **MASPs** should be in the Upgrade Phase 3 Mode; or the **MASPs** must be in full function mode. If the **MASPs** are not in the proper state, the command is rejected with this message.

Error Message

E2980 Cmd Rej: Must be in upgrade phase 3 or full function mode

The term Upgrade Phase 3 Mode means that the **MASPs** are running the approved **GPLs**, but the other network processors are only prepared to be upgraded. The Upgrade Phase 3 Mode is reached by entering the `act-upgrade:action=oamcomplete` command during the upgrading process.

The term Full Function Mode means that the **MASPs** are running the approved **GPLs**. The full function mode is the normal operating mode for the **MASPs**.

2. The system chooses two **LIMs** running either the **SS7ANSI** or **CCS7ITU** applications equipped with an in-service active link based on the best available priority scheme. Each **LIM** must have one signaling link in an in-service active state. These **LIMs** are referred to as the alternate cards. These **LIMs** are the first to be preloaded and eventually crossloaded during the network initialization.

The best available priority scheme used by the `init-network` command is as follows:

All the **LIMs** running either the **SS7ANSI** or **CCS7ITU** applications are searched to create a list of a maximum of four **LIMs** sorted by highest priority link type, with each **LIM** containing at least one active signaling link. The priority of link types are C, B, A, D, and E in that order. **LIMs** with two active signaling links, that contain the same link type as **LIMs** with one active link, are given priority in the list.

After the list has been created, the **LIMs** are identified as alternate or main cards. If four cards are in the list, then two cards are the alternate cards, and two cards are the main cards. If three cards are in the list, then two cards are the alternate cards, and one is the main card. If two cards are in the list, then one card is an alternate card, and one card is the main card. If only one card is in the list, then it is the main card and there is no alternate card. If no cards are in the list, then the `init-network` command is rejected with this message.

Error Messages

E2981 Cmd Rej: Already in nodal isolation

The `init-network` command requires the four **LIMs** running either the **SS7ANSI** or **CCS7ITU** applications with at least one active signaling link on each **LIM**. If four **LIMs** are not available in the **EAGLE**, the `force=yes` parameter must be specified with the `init-network` command. If the `init-network` command is entered with less than four **LIMs** available, and the `force=yes` parameter is not specified, the command is rejected with this message.

E2371 Cmd Rej: Force parameter is required

3. The value of the `mtprsit` (**MTP** restart timer) parameter of the `chg-stpopts` command is checked. If the value of this timer is less than 30 seconds, the `init-network` command is rejected with this message.

Error Message

E2983 Cmd Rej: STPOPTS table MTPRSIT value must be at least 30000.

This makes sure that the **MTP** restart timer does not expire when the `init-network` command is executed and disabling the **MTP** restart feature.

4. The system sets the Inhibit Dynamic Data Loading indicator on the **LIMs** (running the **SS7ANSI**, **CCS7ITU**, or **SS7GX25** applications) **ACMs**, and **ASMs** running the **SCCP** application.

The term dynamic data loading applies to all of the **LIMs** (running the **SS7ANSI**, **CCS7ITU**, or **SS7GX25** applications) **ACMs**, and **ASMs** running the **SCCP** application; and refers to software used to hunt for a card that already has its application software loaded and to crossload dynamic data from that card. Dynamic data is the data maintained on the main assemblies of the **LIMs**, **ACMs**, and **ASMs** that change in response to system conditions.

5. The system reloads all the **ASMs** running the **GLS** application and one of the **ASMs** running the **SCCP** application, if there is more than one **ASM** running the **SCCP** application.
6. After the all the **ASMs** running the **GLS** application have been reloaded, and the one **ASM** running the **SCCP** application has been preloaded. Then the alternate cards are reloaded. After the alternate cards have been reloaded and are waiting to crossload the dynamic data, then all the other **LIMs**, **ACMs**, and **ASMs** running the **SCCP** application, excluding the main cards, are reset.
7. When these **LIMs**, **ACMs**, and **ASMs** have completed resetting, the system resets the main cards.
8. The system removes the Inhibit Dynamic Data Loading indication first on the preloaded **ASM** running the **SCCP** application and the alternate cards. This allows all the **LIMs**, **ACMs** and **ASMs** running the **SCCP** application to complete crossloading and align.
9. All cards reset become active, and traffic is restarted.

5.177 Upgrading the Application Processor of the Main Assemblies from the Intel 286/386 to the Intel 486 Microprocessor (Release 20.0)

The main assembly for the **EAGLE**'s link interface modules (**LIMs**), applications services modules (**ASMs**) and application communications modules (**ACMs**), has been upgraded to the Intel 486 (32 bit, 25 Mhz) microprocessor, replacing the Intel 286 (16 bit, 16 or 20 Mhz) microprocessor. Using the Intel 486 microprocessor more than doubles the internal processing capability of each **LIM**, **ASM**, or **ACM**, and provides 4295 Megabytes of addressable memory map versus just 1 Megabyte for the Intel 286 microprocessor in the non-protected mode. The new design also includes field upgradable socketed memory space to accommodate up to 68 Megabytes of **RAM** for each main assembly.

Intel 486-based modules are currently being shipped to customer sites for all new **EAGLE STP** installations. These are fully backward compatible with the existing Intel

286-based **LIMs**, **ASMs**, and **ACMs**, and function identically when equipped with all pre-Release 20.0 software, now in use on more than 90 installed **EAGLE STPs**. **EAGLE STPs** equipped with the Intel 486-based modules are hardware-ready for all features currently being developed or planned through 1997.

5.178 Use IMT Bus Instead of MBUS (Release 23.0)

In previous releases, the maintenance bus (**MBUS**) has been used to communicate with the cards in the **EAGLE** without using the **IMT** bus. The maintenance bus was used to connect or disconnect cards from the **IMT** bus and to reinitialize the cards in the **EAGLE**. The maintenance bus was carried on the “A” clock cable from the control shelf to the extension shelves.

In Release 23.0, the maintenance bus has been removed from the **EAGLE**, and the messages that were sent across the maintenance bus are now sent on the **IMT** bus. The maintenance bus can now be used for other purposes, such as distributing the clock signals for the high-speed **ATM** signaling links.

The commands now using the **IMT** bus instead of the maintenance bus are: `init-card`, `init-sys`, `disc-imt`, `conn-imt`, `inh-imt`, and `alw-imt`. The operation and performance of these commands from a user’s perspective has not changed.

5.179 User-Initiated Keyboard Locking (Release 22.0)

In Release 22.0, a user will be able to secure the terminal while temporarily away from the terminal without having to log off the terminal with a new command, `lock`.

When the `lock` command is entered, the keyboard is immediately locked, the *Command Executed* response appears in the command information area of the terminal display, a **KEYBOARD LOCKED** indicator is displayed in the lower-right portion of the **VT320** terminal (this indication is not displayed on **KSR** terminals), and a counter of consecutive failed attempts to unlock the terminal is set to 0. The following message appears in the scroll area of the terminal.

```
Terminal keyboard is locked. Enter UNLOCK command to unlock.
```

When the terminal keyboard is locked, the only input allowed on the keyboard is the `unlock` command which is used to unlock the keyboard. If any command other than the `unlock` command is entered while the keyboard is locked, the command is rejected with the following message.

```
E2004 Cmd Rej: Keyboard is locked. Enter UNLOCK command
```

This message is displayed regardless of whether or not the command contained any command syntax errors. In addition, while the keyboard is locked, only these terminal function keys are enabled.

- F6 - refresh screen
- F8 - toggle scroll lock
- F11 - toggle between **VT320** and **KSR** terminal modes

Other terminal function keys are ignored. If one of these function key is pressed no error message is displayed.

When the `unlock` command is entered, the user is prompted for the user's password with the following message.

```
Enter LOGIN password to unlock keyboard :
```

The password that must be entered is the password of the user that was logged on to the terminal when the `lock` command was entered.

If the password entered at the `unlock` command prompt does not match the password of the user logged on to the terminal, then the `unlock` command is rejected with the following error message.

```
E2765 Cmd Rej: Invalid password. Keyboard is locked. Enter UNLOCK  
command.
```

Each time the `unlock` command is entered, the system increments the counter of consecutive failed `unlock` command attempts by 1. If the counter equals or exceeds the login failure threshold for the terminal port as defined by the `mxinv` parameter of the `chg-trm` command, then the following message is issued to each terminal able to receive unsolicited system administrator messages.

```
Info: xxxxxxxxxx successive UNLOCK failures on port yy
```

where:

xxxxxxx = the number of consecutive failed `unlock` command attempts (0 - 4,294,967,295)

yy = the number (1 - 16) of the terminal port on which the failed `unlock` command attempt occurred.

In addition, for every consecutive `unlock` command failure that is an even multiple of login failure threshold value, assuming the login failure threshold is greater than 0 (for example, if the value of the login failure threshold is 3, the even multiple of this value is 6), the terminal port is disabled for the period time specified by the `dural` parameter of the `chg-trm` command.

If any commands are entered during the period of time when the terminal port is disabled, the commands are rejected with the following message.

Error Messages

```
E2770 Cmd Rej: Port temporarily disable due to excessive UNLOCK  
failures.
```

Specifying a value of 0 for the `mxinv` parameter turns off the temporary terminal port lockout feature and no messages regarding `unlock` command failures and login

failures are issued and the terminal port is not disabled. If the value of the `mxinv` parameter is greater than 0 and the value of the `dural` parameter is 0, the **EAGLE** issues the information message reporting the number of consecutive login failures when that number exceeds the value of the `mxinv` parameter, but the terminal port is not disabled.

If the password entered at the prompt from the `unlock` command matches the password of the user that is logged on to the terminal, the keyboard is unlocked. The following message is displayed in the scroll area of the terminal,

```
Info: Keyboard unlocked. xxxxxxxxxx UNLOCK commands were attempted.
```

where xxxxxxxxxx is the number of times the `unlock` command was entered on the terminal.

Any terminal subject to idle terminal monitoring whose keyboard is subsequently locked will not be disabled as long as the keyboard remains locked. As soon as the keyboard is unlocked, the terminal's counter of accumulated idle time is reset to 0 and idle terminal monitoring resumes.

SEAS terminals (a terminal port with the `type=seas` parameter specified) cannot be locked. The `lock` command checks the terminal type of the terminal that the `lock` command is entered on. If the `lock` command is entered on a **SEAS** terminal, the command is rejected with the following message.

```
E2766 Cmd Rej: Command cannot be executed on a SEAS terminal
```

The `unlock` command can be entered on a **SEAS** terminal, however it is always rejected with the following message because **SEAS** terminals cannot be locked. No password prompt is issued to the **SEAS** terminal.

```
E2767 Cmd Rej: Keyboard is not locked
```

Any time a user is automatically logged off a terminal while the keyboard is locked, the keyboard will be unlocked. This includes automatic logoffs that are caused by:

- changing terminal characteristics
- inhibiting or allowing the terminal with the `rmv-trm` or `rst-trm` commands
- executing either the `chg-user` or `dlt-user` commands
- communications loss to the terminal

The system administrator can unlock a locked terminal by taking the terminal out of service with the `rmv-trm` command, then restoring the terminal to service with the `rst-trm` command.

While the keyboard is locked, only inputs to the terminal are monitored. Outputs destined for the terminal continue to be output regardless of the state of the keyboard lock.

The `rept-stat-user` command shows which terminals are currently locked with the entry `lock` in the **COMMAND** field of the output. The following is an example of the output of the `rept-stat-user` command.

```

USER ID          TERM #  IDLE SINCE          COMMAND          STATE
EAGLE            8      97-06-07 06:45:23  lock             IDLE
REPORT COMPLETED

```

5.180 Using the DPC/SSN Parameters and GTA Range in Displaying Global Title Translations (Release 22.0)

This feature enhances both the **SEAS VFY-GTT** and **EAGLE** `rtrv-gtt` commands to support specific values for the `pc` and `ssn` parameters, as well as the end range for the `gta` parameter. This enhancement allows customers with large **GTT** data bases to limit the amount of output for each verify request, thus avoiding the possibility of reaching the 400K **UAL** limit.

The `pc`, `ssn`, and `egta` parameters have been added to **EAGLE**'s `rtrv-gtt` command.

The **SEAS VFY-GTT** command now supports the `dpc`, `ssn`, and `&&-gta` parameters.

The **EAGLE** does not support the relative cost parameter. When this parameter is specified on the **SEAS** interface, the **EAGLE** ignores this parameter. The value 50 is displayed in the **VFY-GTT** output because this parameter is mandatory in the output syntax.

The **EAGLE** only supports one **DPC-SSN** combination for each global title translation (**GTT**). A specific **DPC-SSN** entered with a specific global title address for this command must match the one existing for the specified global title address. However, because only one **DPC-SSN** combination is allowed per **GTT**, specifying ****** for either the **DPC** or the **SSN** for a specific global title address results in the same response as if the specific values were entered.

5.181 Variable-Length Global Title Translation (Release 26.1) (IP⁷ Release 2.2)

The IP⁷ Secure Gateway supports either of the following types of global title translation:

- Standard **GTT** determines which translation table to use based solely on the **Translation Type (TT)** contained in the **SCCP** called party address.
- Enhanced **GTT** determines which translation table to use based on the **TT**, **Numbering Plan (NP)**, **Nature of Address Indicator (NAI)**, and **Global Title Indicator (GTI)**, all of which are contained in the **SCCP** called party address.

For either type of global title translation, each translation table has a fixed length for the numbers it includes.

In previous releases, if the IP⁷ Secure Gateway received a number that had fewer digits than were defined in the table, the IP⁷ Secure Gateway did not perform the **GTT**.

In this release, if the IP⁷ Secure Gateway receives a number that has fewer digits than are defined in the table, the IP⁷ Secure Gateway pads the called party address with special non-decimal characters so that the length of the called party address matches the length used by the table.

(In either release, if the IP⁷ Secure Gateway received a number that had more digits than were defined in the table, the IP⁷ Secure Gateway used as many digits as were defined for the table; for example, if a given translation table contained called party addresses of length 10 and an MSU with a called party address of length 12 was received, the IP⁷ Secure Gateway used the first 10 digits.)

If the user specifies an individual entry or range of entries on the `ent-gtt` command (used to provision a standard **GTT** translation table) or on the `ent-gta` command (used to provision an enhanced **GTT** translation table) with a value that has fewer digits than the predefined length of the table, the IP⁷ Secure Gateway adjusts the internal representation of the specified value to match the length of the table.

Whenever a global title address is displayed, it is displayed as it was entered at the terminal.

5.182 Variable Length GTT (Release 26.1)

Description

Variable Length **GTT** provides customers the ability to provision Global Title entries of varying lengths to a single **Translation Type** or **GTT Set**. In prior releases, only Fixed Length **GTT** was supported, meaning that all Global Title entries assigned to a single **Translation Type** or **GTT Set** had to be the same length.

With Variable Length **GTT**, customers can assign Global Title entries of up to 10 different lengths to a single **Translation Type** or **GTT Set**. These lengths are not defined when entering the **Translation Type** or **GTT Set**. As the entries are entered, the software keeps track of the length, allowing only 10 different lengths.

When 10 different lengths are specified for a **Translation Type** or **GTT Set**, only Global Title entries with lengths matching those defined are allowed. That is, if the craftsman has entered 10 different lengths and a new entry is entered with a length that does not match one already entered, the new one will not be allowed.

This feature is controlled with a feature bit. This feature bit may be set independently of whether Enhanced **GTT** is used or not.

In addition to satisfying the needs of European customers, this feature provides U.S. customers with an easier method of provisioning **GTT** data, since shorthand ranges can be used to represent large groups of **GTAs**. Thus more specific **GTAs** can be provisioned as exceptions to these larger groups.

Consider the following example:

Table 5-29 Variable GTT Example

TT	GTA	EGTA	PC-SSN	XLAT	RI
11	0	9	1-1-1	DPC	GT
11	9193	9194	1-1-2	DPC	GT
11	919460	919460	1-1-3, 23	DPCSSN	SSN
11	9193800000	9193800999	1-1-4, 25	DPCSSN	SSN

Table 5-29 (Cont.) Variable GTT Example

TT	GTA	EGTA	PC-SSN	XLAT	RI
11	9193831000	9193833999	1-1-4, 25	DPCSSN	SSN

In this example, the customer wishes to perform final **GTT** on all numbers matching the last three entries. Note the shorthand used in the third entry, as this single entry represents all numbers beginning with the first six digits of 919460, i.e. 9194600000 - 9194609999. Any number not matching the last three entries requires intermediate **GTT**, and is routed to different nodes based on the ranges specified. The first entry provides a "default" for all **GTAs** not matching more specific **GTAs** entries for this translation type.

As another example, consider the possibility that an **MSU** comes in with the address "9193805000". The address is a 10-digit number, and therefore would first get looked up on the 10-digit tree. In this example, these would fail. The 6-digit tree would be looked up next. This would fail, too. Finally, the address would match the 4-digit range of 9193 to 9194.

Upgrade Considerations

This section considers the software upgrade requirements of the Variable Length **GTT** feature, which involves a database upgrade. The database upgrade is impacted by the following changes:

- With this feature, the previous implementation of "Padded Variable Length **GTT**" becomes obsolete. An upgrade path is provided for customers who have this feature activated. (See [Hardware Required](#) for more information.)
- Removing any padded entries from the **GTT** database and entering them into new trees for the corresponding **GTT** Set also impacts the **GTT_SET** table entry size.
- If the **PVGTT** and **LNP** features are on, a **DSM** is required. See [Hardware Required](#) for more information.

Hardware Required

This feature has the same hardware requirements, provisioning rules, and ratios as does **GTT**. However, in order to meet performance requirements, the card required for this feature may need to be upgraded. The choice of hardware will be determined by the sales team based on the current customer database and needs. The hard and fast rule is:

- If **LNP** is **OFF**, a **TSM** should be able to provide the desired performance.
- If **LNP** is **ON**, a **DSM** is needed.

At a minimum, the Variable **GTT** feature requires **TSM** cards for **SCCP** functionality prior to turning on the feature bit. Due to the possible combinations available with **SCCP** features, [Table 5-30](#) can be used to clarify the required hardware for **VGTT**, as well as other **SCCP** features.

Table 5-30 VGTT Required Hardware

Feature	Required Hardware
VGTT	TSMs (N+2)
EGTT	TSMs (N+1)
VGTT + EGTT	TSMs (N+2)
G-PORT, G-FLEX, INP	DSMs (N+1)
VGTT/LNP	DSMs (N+1)
LNP (<12 million)	TSM (N+1)
LNP (>12 million)	DSM (N+1)
GTT	ASM/TSM (N+1)

5.183 V-Flex Voice Mail Router (Release 37.6, 39.0, EPAP 9.5, 11.0)

The V-Flex Voice Mail Router (V-Flex) feature is used to route calls to a specific voice mail server (**VMS**) based on subscriber and call context data. These data are provisioned using the EAGLE 5 ISS **MMI** port and **EPAP** PDBI interface.

The V-Flex feature is implemented as a local **SCCP** subsystem on the EAGLE 5 ISS and co-exists with the EAGLE 5 ISS standard STP functionality. The feature co-exists with EPAP-based applications, such as G-Port, G-Flex, IS41 GSM Migration, and GSM MAP Screening.

The V-Flex feature supports the following types of calls:

- Normal Deposit: A call is made and redirected to the recipient's voice mail.
- Direct Deposit: A call is made directly to the recipient's voice mail.
- Short Code Retrieval: A subscriber retrieves voice mail for the same device that they are using
- Normal Retrieval: A subscriber uses a device to retrieve voice mail for a separate, specified device

The V-Flex feature performs as follows:

1. A message service center (**MSC**) receives an initial address message (**IAM**) for a call being routed to a VMS.
2. The MSC uses subscriber and call context information from the IAM to generate an initial detection point (**IDP**) message and send this message to the EAGLE 5 ISS.
3. The EAGLE 5 ISS analyzes the information provided in the IDP, performs appropriate database searches, generates a message that contains routing information, and sends this message to the MSC.
4. The MSC uses the routing information provided by the EAGLE 5 ISS to connect to the correct VMS.

**Note:**

The V-Flex feature allows a maximum of two network entities (**NEs**) to be associated with a directory number (**DN**) or with a DN block.

5.183.1 Feature Control Requirements

The V-Flex feature has the following feature control requirements:

- A FAK for part number 893-0167-01
- The GTT feature bit must be turned on before the feature can be enabled.
- The STPOPTS:DefCC and DefNDC options must be provisioned before the feature can be turned on.
- The feature cannot be turned off after it has been turned on.
- A temporary FAK cannot be used to enable the feature.

5.183.2 Hardware Requirements

The V-Flex feature requires Service Module cards. The feature cannot be enabled if TSM cards that are running the SCCP application are present in the system.

5.183.3 Limitations

The 150-character limit on command length may prevent a single `ent/chg-vflx-vmsid` command from fitting on a single line.

5.184 Warning Message When LIMs Added with Insufficient TSMs (Release 25.0)

This feature enforces the current **TSM** provisioning rules of one **TSM** at a minimum for every 16 **LIMs** when a **LIM** is added. When a **LIM** is added, if there are not enough **TSMs**, a warning message is displayed. The craftsperson then has the option to override the warning, forcing the card to be entered.

Per the **EAGLE** engineering rules, a minimum of 1 **SCCP (ASM or TSM)** card is required for each group of 16 low-speed **LIMs**, with one additional **SCCP** card required per system for N+1 redundancy.

Since one **HSL** can provide the data transfer capability of approximately 16 **DS0s**, 2 **HSL ATM** cards can be supported by a minimum of 1 **SCCP** card.

The feature enforces the minimum configuration.

When a low-speed **LIM** card (`ss7ansi`, `ccs7itu`, `ss7gx25`) or a high-speed **LIM** card (`atmansi`) is entered via the `ent-card` command, the number of provisioned **SCCP** cards is evaluated to ensure that the minimum required configuration is maintained. The minimum configuration value is one **SCCP** card for each multiple of 16 **LSLs**, or 2 **HSLs**, rounded up.

One additional **ASM/TSM** card is required to maintain N+1 redundancy.

The warning is accomplished via command error or other means, and does not produce an alarm.

The craftsperson must explicitly override the warning to provision a card that breaks the required configuration rule. When this is done, the warning still is displayed.

When the warning is overridden, the event is logged in the security log.

5.185 Weighted GTT Loadsharing (Release 36.0)

Description

The Weighted **GTT** Loadsharing feature is an enhancement to intermediate and final **Global Title Translation** loadsharing. Provisioning provides control over **MAP** and **MRN** entities so that unequal route costs can be defined within a loadsharing group. Provisioning also controls loadsharing groups so that if insufficient capacity is available within a loadsharing group, the group is not used.

A feature access key (**FAK**) for part number 893017001 is required to enable the Weighted **GTT** Loadsharing feature.

- The **GTT** feature must be on before the **WGTTLS** feature can be enabled.
- After the feature is enabled, it can be turned on and turned off.
- No temporary **FAK** is allowed for the feature.

The Weighted **GTT** Loadsharing feature controls loadsharing through the **MAP** and **MRN** entities within a **MAP** group or **MRN** group. **MAP** entities distribute **MTP**-routed **GTT** traffic to the final destination. **MRN** entities relay **MTP**-routed **GTT** traffic to other nodes for further **GTT** processing.

The Weighted **GTT** Loadsharing feature provides the following two methods to control the distribution of **GTT** traffic through **MAP** or **MRN** groups:

- Individual weighting for each **RC** group entity

Individual weighting assigns different load capacities, in the range of 1 to 99, to the entities of an **RC** group. Each entity receives a percentage of the network traffic proportionate with its weight relative to the total weight of the **RC** group.

- In-service threshold of each **RC** group

The in-service threshold is the minimum percentage of the total of the provisioned weights of an **RC** group that must be available for the **RC** group to receive network traffic. An in-service threshold of 1% means that the group will be used if any member is available. The entire **RC** group is considered unavailable for network traffic if the percentage of the available weights is less than the in-service threshold. The **RC** group is considered available if the percentage of the available weights is greater than or equal to the in-service threshold. If an **RC** group is available, network traffic can be sent to any available entity in the **RC** group.

WGTTLS adds 2 new modes for loadsharing:

- Weighted Load-Share
- Weighted Combined Load-Share.

WGTTLS can be turned on and off after it is enabled. The feature operates as follows:

- If weights are not assigned to a group, the original mode (Solitary, Dominant, Load-Shared, or Combined Load-Shared/Dominant) is used.
- If **WGTTLS** is enabled and turned on, and weights are assigned to entities within an **MRN** group or a **MAP** group in Load-Shared mode, Weighted Load-Share mode is used.
- If **WGTTLS** is enabled and turned on, and weights are assigned to entities within an **MRN** group or a **MAP** group in Combined Load-Shared/Dominant mode, Weighted Combined Load-Share mode is used.

Hardware Requirements

The Weighted **GTT** Loadsharing feature has the following hardware requirement:

- **DSM** cards
- **TSM** cards that run the **SCCP** application cannot be provisioned if the feature is enabled. The feature cannot be enabled if **TSM** cards that run the **SCCP** application are configured in the system.

Limitations

The Weighted **GTT** Loadsharing feature has the following limitations:

- Outbound traffic distribution is affected by incoming traffic distribution. If the **OPC**, **SLS**, and incoming **Link ID** do not span a diverse range, then weighted distribution may not be able to be maintained. Maintaining the same **DPC** for the transaction is given priority. This affects **SCCP** Class 1 Sequenced traffic only. It does not affect Class 0, or Class 1 with **sccpopts:class1seq=off**, which are balanced regardless of **OPC**, **SLS**, and incoming **Link ID**.
- When weights are assigned or changed in an **MRN** or **MAP** group that is handling transaction-based traffic, the destination assignment of some transactions will change. This may cause some **MSUs** of the transaction to be directed to one destination and some to another destination.
- If all **RC** groups in a **MAP** or **MRN Group** are Threshold-Prohibited, traffic loss will occur, even though some entities within the group are available. The decision to avoid congestion takes precedence over the routing all traffic.

5.186 Weighted SCP Load Balancing (Release 27.2)

The Weighted **SCP** Load Balancing feature allows the user to enter up to eight **PC/SSNs** into a mated **PC/SSN** group. Previously, only two mated **PC/SSN** could be entered. The Mated **PC/SSN** group can be identified by specifying any **PC/SSN** within the group. This feature also increases the number of **SSN**'s per **PC** to 12.

With this feature, **EAGLE** now supports four different modes for **PC/SSN** groups:

- Solitary
- Dominant
- Load Shared
- Combined Dominant/Load Shared (new)

Combined Dominant/Load Shared mode is new for this feature; the other modes are existing modes. Previously, the mode was determined by the multiplicity parameter.

This parameter is no longer used. Instead, the mode is determined by the relative cost of the **PC/SSNs**.

A group of replicated **PC/SSNs** are in Combined **Load Sharing/Dominant Mode** when at least two of the **PC/SSNs** have the same relative cost, and another node subsystem in the group has a different relative cost. For example, the user enters the mated **PC/SSNs** in [Table 5-31](#):

Table 5-31 MAP for Combined Load Share Mode

PC/SSN	Relative Cost
1-1-0/10	10
1-1-1/10	10
1-1-2/10	20
1-1-3/10	20

The user then enters the Translations in [Table 5-32](#):

Table 5-32 Translations for Combined Load Share Mode

Translation Type	GTA	PC/SSN
10	000 to 999	1-1-0/10

In this example, if both 1-1-0/10 and 1-1-1/10 are available, **EAGLE** will evenly distribute **MSUs** for **TT** 10 to 1-1-0/10 and 1-1-1/10. If 1-1-0/10 fails, **EAGLE** will send all **MSUs** to 1-1-1/10. If both 1-1-0/10 and 1-1-1/10 fail, **EAGLE** will evenly distribute the **MSUs** to 1-1-2/10 and 1-1-3/10.

EAGLE will not guarantee sequencing when Combined **Load Sharing/Dominant** mode is used. **MSUs** with the same **SLS** values may be sent to different nodes.

Hardware Requirements

There are no additional hardware requirements for this feature.

Upgrade Considerations

- During upgrade, the adjacency parameter is deleted, and the `srm` parameter remains unchanged.
- During upgrade for mated subsystems in dominant mode, the primary subsystem is assigned a relative cost of 10, and the backup subsystem is assigned a relative cost of 50.
- During upgrade for mated subsystems in shared mode, both subsystems are assigned a relative cost of 50.
- During upgrade for subsystems in solitary mode, the subsystem is assigned a relative cost of 10.
- During upgrade, the multiplicity parameter is deleted.

Limitations

- The **EAGLE** is not required to support the 2-step NetPilot **GTT** feature.

- The **EAGLE** does not guarantee **MSU** sequencing when **Load Sharing** is used. **MSUs** with the same **SLS** values may be sent to different nodes.

5.187 Wireless Number Portability (Release 23.1)

This feature enhances the **Local Number Portability** feature to allow wireless service providers to query the **LNP** database for ported telephone numbers. The query is used to find the location routing number associated with the ported telephone number so the telephone call can be routed to its proper destination.

The **Wireless Number Portability** feature can only be used for **ANSI** messages. The **Wireless Number Portability** feature is not defined for **ITU** messages.

When a query arrives at the **EAGLE** from a wireless service provider, it is examined for a translation type associated with the wireless number portability translation type service.

If the query contains a wireless number portability translation type (the route on **GT** routing indicator) and requires global title translation, the query is routed to the local **LNP** query subsystem at the **EAGLE**'s true point code.

The local **LNP** query subsystem processes the query to find the location routing number associated with the telephone number contained in the query. A response is sent to the originator of the query with the location routing number for the ported telephone number.

This type of query cannot be routed to an external node. This means that the processing of **Wireless Number Portability** queries cannot be split across multiple network elements.

If global title translation is not required and if the destination of the query is the **EAGLE**'s destination point code and subsystem, the query is routed to the local subsystem. If the destination of the query is not the **EAGLE**'s destination point code and subsystem, the query is routed to the destination point code in the query.

The **Wireless Number Portability** feature must be turned on with the `chg-feat` command and must have the translation types sent from wireless service providers configured in the database with the `ent-lnp-serv` command.

5.188 X.25/SS7 Gateway Feature (Release 20.0)

Overview

The **EAGLE X.25/SS7** gateway feature connects **SS7** and X.25 networks. This enables applications to connect using different transport services. The gateway converts each X.25 packet to **SS7 MSU** and routes it to an **SS7** network. **SS7 MSU** going the other way are converted to X.25 packets. The gateway is physically positioned between the **SS7** network and X.25 network, and it transports messages from one network to the other using the services of **SS7 SCCP (Signaling Connection Control Part)** protocol.

The X.25/**SS7** gateway feature is an optional feature that is turned off by default. To use the X.25/**SS7** gateway feature, it must be turned on by entering the appropriate command. Once this feature is turned on, it cannot be turned off.

The gateway supports the following two types of connectivity to the X.25 node.

- Direct connectivity
- Connectivity through a public or private data network

The **EAGLE** supports 1024 logical channels. All X.25 entities are assigned an **SS7** point code and **SCCP** subsystem number. The individual X.25 connections on the **EAGLE** are assigned X.25 addresses, as well as alias point codes. These are then mapped in the **EAGLE** routing table to logical channels. This allows X.25 messages (which use connection-oriented procedures) to be routed and maintained in the **SS7** network (which uses connectionless procedures).

The **EAGLE** uses a **LIM** equipped with a 486 processor and a generic program load (**GPL**). The **LIM** supports the **DS0A** or **OCU**, and **V.35** interfaces at these lines speeds.

- **DS0A** at 56 and 64 kbps
- **OCU** at 56 and 64 kbps
- **V.35** at 4.8, 9.6, 19.2, 56, and 64 kbps

The X.25 gateway feature requires that any data that is transmitted must be sent on a connection. A connection represents a route between two application entities (one in the X.25 domain and one in the **SS7** domain). It must exist before any messages can be transferred. The connection can be one of three types:

- **PVC** (permanent virtual circuit): A fixed connection that can only be altered through administration.
- **SVCA** (switched virtual circuit-automatic): A connection established by the **STP** as soon as the X.25 gateway card initializes.
- **SVCR** (switched virtual circuit-remote): A connection established by the X.25-user end when necessary.

Automatic **SVCs** (**SVCA**s) are assigned when the X.25 **LIM** card is booted. The virtual connection is based on information in the routing tables of the **EAGLE**. The X.25 destination (**DE**) and the **SS7** node must be defined in the **EAGLE** database in advance.

Remote **SVCs** (**SVCR**s) are assigned on an as-needed basis. This means when an incoming message from the X.25 network or the **SS7** network is received, a “virtual” destination and originating point code are assigned.

For these connections, a route must be defined through administration. Every application entity that can be connected through the gateway must be defined. The association between the application entities must also be defined.

In addition to the normal **MTP** and **SCCP** processing, the X.25 gateway feature provides two new components for the **STP** – gateway routing and protocol conversion.

An X.25 link appears to the **STP** as though it is an **SS7** link. Adjacent point codes are either the originating point code of the X.25 distant end (if the connection is direct), or a virtual point code (if the connection is through a network). This is equivalent to routing through an adjacent **STP** to the signaling points connected to it. See [Figure 5-34](#).

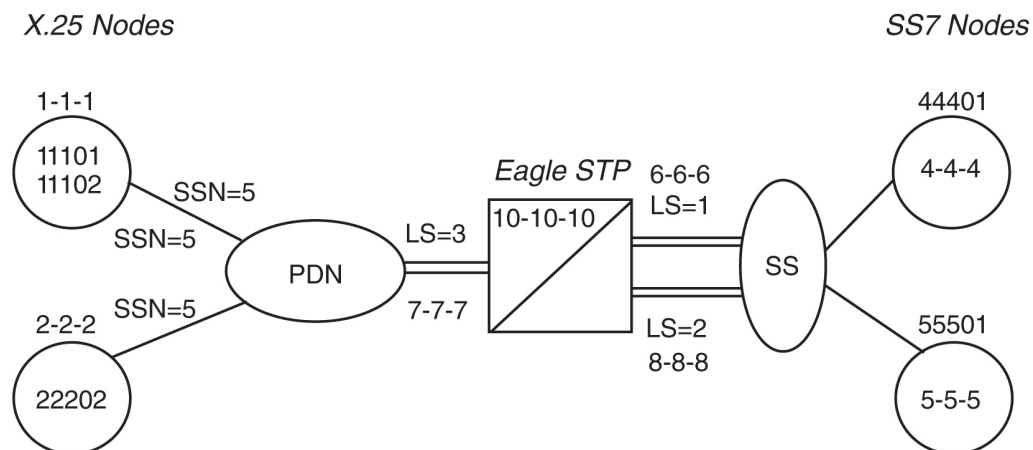
Figure 5-34 Gateway Network

As messages travel from the X.25 network to the **SS7** network, the gateway determines the destination point code (**DPC**) and adds the **SS7 SCCP** and **MTP** envelopes to the **TCAP** message. The gateway determines the virtual circuit and removes the **SCCP** and **MTP** envelopes on messages transmitted from the **SS7** network side to an X.25 destination.

Other attributes of the gateway are as follows:

- Each X.25 link supports up to 255 logical channels as **SVCs** or **PVCs** or a combination.
- All X.25 network-initiated calls are accepted when the calling X.25 node is correctly defined in the **STP**.
- Gateway screening is supported from the X.25 to the **SS7** network.
- Routing does not occur through the X.25 gateway between two X.25 points.
- X.25 networks that do not supply the calling address in the call request are not supported for network-initiated connections.

Message Conversion

The **EAGLE** performs message conversion for all traffic in both directions. The message conversion removes and adds protocol envelopes used by the X.25 and **SS7** networks. The data portion of the message is not changed. The **MTP/SCCP** of **SS7** is converted to X.25 and reverse, depending upon the traffic direction.

Address Mapping

Messages originating from the **SS7** network destined for the X.25 network can be routed by the destination point code (**DPC**) assigned to the X.25 entity in the X.25 routing table (called Xpc). This allows **SS7** entities to address the X.25 network without knowing X.25 addresses.

The X.25 routing table provides the X.25 address of each X.25 entity, an **SS7** point code for each of the X.25 entities, a subsystem number for **SCCP** routing, the method of routing to be used (Xpc or normal **SS7** routing) and the logical channel to be used between each of the specified X.25 entities and the **SS7** entities.

Routing by the X.25 point code assignment allows many **SS7** entities to communicate to one X.25 entity without each **SS7** entity having to know the X.25 address, and allows all **SS7** entities to connect to the X.25 entity over one logical channel. This provides for easier routing table administration. Without this capability, every possible connection between X.25 and **SS7** entities would have to be defined in the **EAGLE** X.25 routing table.

To support the gateway function, the entities within the X.25 network must be assigned an **SS7** point code. This point code is assigned in the **EAGLE** X.25 routing table using **EAGLE** administration commands. The routing table specifies the X.25 address, the **SS7** point code assigned to both the X.25 entities and any **SS7** entities which need to connect to X.25, a subsystem number for the X.25 entities, and the logical channel to be used on the X.25 link for connections between the specified entities. Full point code routing is used to route packets to a pseudo X.25 point code.

Each **EAGLE** connection to the X.25 network is assigned an X.25 address as well. This allows routing of data from the X.25 network to the **SS7** network. An **SCCP** subsystem number is assigned to the X.25 destination to enable global title translation to the X.25 entity.

Logical channels are also assigned in the X.25 routing table. Each X.25 entity must be assigned an **SS7** destination, to allow logical channel assignments to be made for the connection. If there are to be several **SS7** entities connecting to the X.25 entity over the same logical channel, a wild card entry can be made in the routing table. This allows any **SS7** entity to establish a connection over the specified logical channel, but only one connection can be made at any one time.

X.25 Gateway Routing

X.25 gateway routing is performed through four different functions:

- Connection determination
- X.25 connection control
- Same-link management
- Logical channel to network management mapping

Connection Determination

The destination address for X.25 is defined as a destination element (X.25 **DE**). An X.25 **DE** is an object on the X.25 network to which a connection can be made and has a point code assigned to it. An X.25 link can be either point-to-point (direct) or through an intermediary network. A destination for **SS7** is a point code, plus an optional subsystem number (**SSN**).

A destination for X.25 is dependent upon whether a connection is established. A *connection* is defined as a pair of destinations that are exchanging messages. The destination for X.25 is an X.25 address before connection, and a logical channel (**LC**) after connection. One of the destinations must be in the X.25 domain and the other in the **SS7** domain. See [Figure 5-35](#).

Figure 5-35 X.25 Gateway Connection Determination

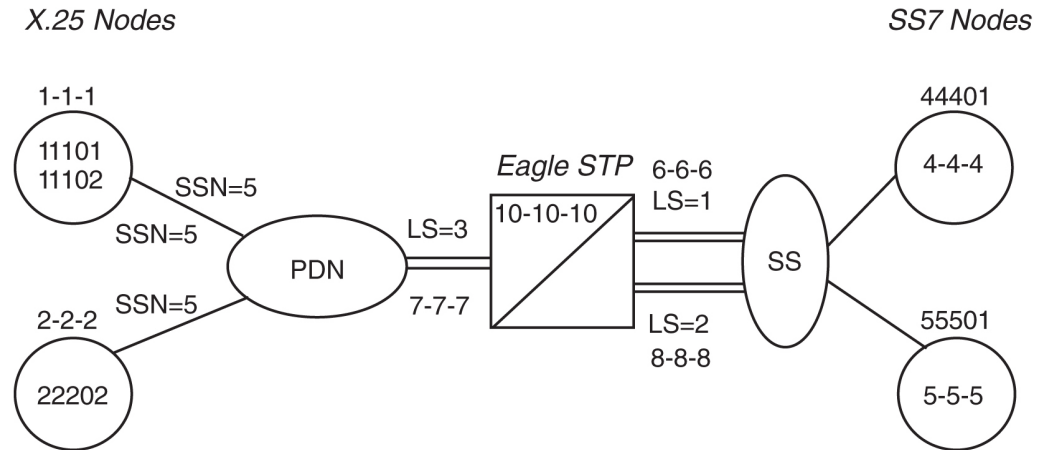

The connection is determined using the gateway routing table. This process can be divided by whether the message arrives from the X.25 side (inbound) or the **SS7/MTP** side (outbound):

- Inbound messages:

If the logical channel on which the message arrives is in the connected state, it already points to an entry in the gateway routing table. The destination point code (**DPC**) is the value in the **SS7** point code field. The origination point code (**OPC**) is the value in the X.25 point code field.

For an incoming **SVC**, the X.25 user must first establish the connection.
- Outbound messages:

The **DPC** is used to locate the connection on which to send the message. The order of the lookup in the routing table is as follows:

 1. The **STP** locates an entry in the X.25 point code field that matches the **DPC**. If no entry is found for that point code, the gateway produces **MRN #1140** and the **MSU** is discarded.
 2. The **STP** verifies that the **OPC** matches the **SS7** point code field. If there is no match, the gateway produces **MRN #1134** and the **MSU** is discarded.
 3. After the connection entry is found in the gateway routing table, the **STP** examines the card address field and proceeds as follows:

Table 5-33 Card Address Field Response

If...	then...
the card address is the same as the card that receives the MSU ,	the process is complete and the message passes to format conversion.
the card address is not the same card that receives the MSU ,	the STP passes the MSU to "single link" management for the card defined in the card address field.

X.25 Connection Control

There is an additional routing requirement, connection routing and control, that is different from **SS7** routing. The X.25 requires that a connection be present between the gateway and the X.25 **DE** before any messages can be exchanged. A connection is established depending upon when and where the connection is made.

A fixed connection route is defined through administration and can be either **PVC** (permanent virtual circuit), **SVCA** (switched virtual circuit-automatic) or **SVCR** (switched virtual circuit – remote). If the connection type field is **PVC**, the **PVC** is already established when the link is initialized through provisioning in the **PDN** and **STP**. The **PVC** remains in effect while the link is operational.

If the connection type field is **SVCA**, the connection is established by the designated **LIM** card (defined in the location field) immediately after the link becomes initialized. It is possible that the remote end becomes available during this cycle, and makes the connection from the remote end. The remote end could make the connection to any card. The connection remains in effect while the link is operational or until the remote end fails or clears the connection.

If the connection type field is **SVCR**, the connection can only be made by the X.25 **DE** as follows:

If an X.25 **DE** wants to send a message to an **SS7** node, and the **STP** has not established a connection to that node, it attempts to establish one before sending the message. The X.25 **DE** establishes the connection by sending a call request to the **STP** with identification in the calling address field, and the **SS7** node in the called address field.

When the **STP** receives the incoming call, the **STP** verifies both the calling and called addresses using the X.25 address and **SS7** address fields. If the **STP** finds an entry for the X.25 address pair, it checks to see if a connection is active.

Table 5-34 X.25 Address Pair Response

If...	then...
the connection is active,	the STP clears the incoming call.
the connection is not active,	it is set as active.
an entry for the X.25 address pair is not found,	the STP checks the X.25 Destination Table to see if the designated X.25 addresses are present.
both addresses are present (the caller is in the X.25 domain and the called address is in the SS7 domain),	the connection is established and a temporary entry is added to the database.

Same Link Management

X.25 requires that if there is a set of links into a **PDN** (or directly to an X.25 **DE**), a response to a request must be returned on the same link and logical channel as the request was received. Because **MTP** routing does not use a particular link on a linkset, it is likely that a response would go to a non-originating **LIM**. Same link management assures that the message is sent out on the same link. This is achieved by each **LIM** informing all other **LIMs** when the state of a connection changes.

Logical Channel to Network Management Mapping

The **EAGLE X.25/SS7** gateway provides management procedures for failed X.25 logical channels. This feature allows traffic destined for failed logical channels to be rerouted to an alternate route.

When configuring logical channel to network management mapping (**LC2NM**), you must determine if the X.25 entity is expecting associated queries and responses to use the same logical channel or if they may be assigned to different logical channels. If associated queries and responses can be received over different logical channels, load balancing and failure recovery through alternate routing is supported.

5.189 XUDT Conversion Enhancements (Release 43.0)

The XUDT Conversion Enhancements consists of two parts:

- A new XUDT UDT Conversion feature allows XUDT(S) < - > UDT(S) conversion to occur based on the Destination Point Code (DPC) for MTP-routed and EAGLE-generated SCCP messages. Format conversions for both segmented and non-segmented messages are supported: however, the system does not perform segmentation or reassembly.
- The existing ANSI-ITU-China SCCP Conversion feature is enhanced to support XUDT(S) conversion for MTP-routed and GT-routed SCCP messages. As part of this enhancement, the ANSI-ITU-China SCCP Conversion feature is now referred to as the ANSI/ITU SCCP Conversion feature.

For GT-routed messages and MTP-Routed SCCP messages that are processed on Service Module cards, XUDT UDT conversion is applied after the ANSI/ITU SCCP Conversion feature processes the messages.

The ANSI/ITU SCCP Conversion feature and the XUDT UDT Conversion feature can operate independently of each other.

5.189.1 Feature Control Requirements

- The XUDT UDT Conversion feature requires a FAK for Part Number 893-0353-01.
- The XUDT UDT Conversion feature cannot be turned off after it has been turned on.
- A temporary FAK cannot be used to enable the XUDT UDT Conversion feature.
- The ANSI/ITU SCCP Conversion feature requires a FAK for the existing Part Number 893-0120-01.

5.190 Year 2000 Compliance (Release 23.1)

Overview

This feature ensures that there are no date-related problems with the **EAGLE** or created by the **EAGLE** on or after January 1, 2000. The date shown in all outputs from the **EAGLE** continue to be shown as two digits.

The **EAGLE** performs all date and time-of-day operations within the range of dates from January 1, 1995 to December 31, 2036. January 1, 1995 was chosen as the

starting date for the range of dates because several **EAGLE** features implemented with Release 21.1 have it as the defined start date.

All **EAGLE** software has been modified to represent all dates unambiguously (that is, the year represented as 00 means the year 2000). The digits 95 through 99 represent the years 1995 through 1999. The digits 00 through 36 represent the years 2000 through 2036. For all software modifications in this feature, the date representations have been made to comply with the date formats shown in *Data Elements and Exchange Formats - Information Exchange - Representation of Dates and Time, ISO 8601, 1998*. The **EAGLE** software that is fully compliant with the requirements of the Year 2000 feature does not need to be modified to comply with *Data Elements and Exchange Formats - Information Exchange - Representation of Dates and Time, ISO 8601, 1998*.

Each year that is divisible by four is a leap year, with the exception of those years that end in "00," such as 1900. The one exception is that years that are divisible by 400 are leap years, such as 1600 and 2000. The **EAGLE** recognizes the year 2000 as a leap year.

This section is divided into two parts:

- [Year 2000 EAGLE Compliance](#), shows how the Year 2000 feature applies to the **EAGLE**.
- [OAP Year 2000 Compliance](#), shows how it applies to the **OAP**.

Year 2000 EAGLE Compliance

This section lists the Year 2000 requirements, conditional requirements, and objectives that the **EAGLE** complies with as defined in the Bellcore document, *Year 2000 Generic Requirements: Systems and Interfaces, GR-2945-CORE, Issue 1, BELLCORE, December, 1996*.

The compliance matrix is a table listing the requirement number, objective number, or conditional requirement number as defined in the Bellcore document, the **EAGLE**'s level of compliance with the requirement, objective, or conditional requirement, and any comments that may apply to these items.

A requirement is a feature or function of an **STP** that Bellcore has determined must be a part of the **STP** to function properly. A requirement is identified in this appendix with the letter R in parentheses, (R).

A conditional requirement is a feature or function of an **STP** that Bellcore has determined is necessary in certain applications, depending on how the **STP** is deployed. A conditional requirement may depend on other requirements, objectives, or conditional requirements. A conditional requirement is identified in this appendix with the letters **CR** in parentheses, (**CR**).

An objective is a feature or function of an **STP** that Bellcore has determined is a desirable feature or function for the **STP** to have, but not required to have. An objective is identified in this appendix with the letter O in parentheses, (O).

There are four levels of compliance used in this compliance matrix.

- Fully compliant
- Partially compliant
- Not compliant
- Not applicable

The table caption for each table refers to the section of the *Year 2000 Generic Requirements: Systems and Interfaces, GR-2945-CORE, Issue 1, BELLCORE, December, 1996* document where the item can be found.

Table 5-35 Section 2.1. Date-Sensitive Criteria – System Integrity

Bellcore Requirement	Level of Compliance	Comments/Exceptions
(R) 2-1	Fully Compliant	
(R) 2-2	Fully Compliant	The minimum range for the EAGLE is 1/1/95 - 12/31/36
(R) 2-3	Not Applicable	The EAGLE does not perform date conversions, computations, and comparisons using the Gregorian Calendar.
(R) 2-4	Fully Compliant	
(R) 2-5	Fully Compliant	
(R) 2-6	Fully Compliant	
(R) 2-7	Fully Compliant	

Table 5-36 Section 2.2. Date-Sensitive Criteria – Application Integrity

Bellcore Requirement	Level of Compliance	Comments/Exceptions
(R) 2-8	Fully Compliant	
(R) 2-9	Fully Compliant	
(R) 2-10	Fully Compliant	
(R) 2-11	Not Applicable	The EAGLE does not perform delayed execution.
(R) 2-12	Fully Compliant	
(R) 2-13	Fully Compliant	
(R) 2-14	Fully Compliant	
(R) 2-15	Fully Compliant	
(R) 2-16	Not Applicable	No hashing or random number generation is performed.
(R) 2-17	Fully Compliant	
(O) 2-18	Fully Compliant	
(R) 2-19	Fully Compliant	
(R) 2-20	Fully Compliant	

Table 5-37 Section 3. User Interface

Bellcore Requirement	Level of Compliance	Comments/Exceptions
(R) 3-1	Fully Compliant	
(R) 3-2	Fully Compliant	
(R) 3-3	Fully Compliant	
(R) 3-4	Fully Compliant	

Table 5-37 (Cont.) Section 3. User Interface

Bellcore Requirement	Level of Compliance	Comments/Exceptions
(O) 3-5	Partially Compliant	When two digits are used, Year is displayed in unambiguous format, 95 - 99 represents the 20th century, 00 - 36 represents the 21st century.
(R) 3-6	Fully Compliant	
(R) 3-7	Fully Compliant	
(R) 3-8	Fully Compliant	

Table 5-38 Section 4. Machine-to-Machine Interface

Bellcore Requirement	Level of Compliance	Comments/Exceptions
(O) 4-1	Not Applicable	The EAGLE will comply with this objective if an external communication system uses the ISO 8601 date format.
(O) 4-2	Not Applicable	The EAGLE will comply with this objective if an external communication system uses the ISO 8601 date format.
(R) 4-3	Not Applicable	See OAP Compliance Matrix .
(CR) 4-4	Fully Compliant	
(CR) 4-5	Fully Compliant	
(CR) 4-6	Fully Compliant	
(CR) 4-7	Fully Compliant	
(R) 4-8	Not Applicable	The EAGLE does not support BAF/MDR records.
(R) 4-9	Not Applicable	The EAGLE does not support BAF/MDR records.
(R) 4-10	Not Applicable	The EAGLE does not interact with an MSR system.
(R) 4-11	Not Applicable	The EAGLE does not generate MWI Control operations.
(R) 4-12	Not Applicable	The EAGLE does not perform ISDN PRI signaling
(R) 4-13	Not Applicable	The EAGLE does not interact with an MSR system.

Table 5-39 Section 5. Management Function Areas

Bellcore Requirement	Level of Compliance	Comments/Exceptions
(R) 5-1	Fully Compliant	
(R) 5-2	Not Applicable	See OAP Compliance Matrix .
(CR) 5-3	Fully Compliant	
(CR) 5-4	Fully Compliant	
(CR) 5-5	Not Applicable	The EAGLE does not perform delayed activation.
(CR) 5-6	Not Applicable	The EAGLE does not perform scheduled configuration data change.

Table 5-39 (Cont.) Section 5. Management Function Areas

Bellcore Requirement	Level of Compliance	Comments/Exceptions
(CR) 5-7	Not Applicable	The EAGLE does not perform reservation configuration data change.
(R) 5-8	Fully Compliant	
(R) 5-9	Fully Compliant	
(CR) 5-10	Not Applicable	The EAGLE does not perform delayed activation.
(R) 5-11	Fully Compliant	
(R) 5-12	Fully Compliant	
(CR) 5-13	Not Applicable	The EAGLE does not support automatic backups.
(CR) 5-14	Not Applicable	The EAGLE does not support automatic backups.
(CR) 5-15	Not Applicable	The EAGLE does not support automatic backups.
(CR) 5-16	Not Applicable	The EAGLE does not support automatic backups.
(CR) 5-17	Fully Compliant	
(O) 5-18	Fully Compliant	
(CR) 5-19	Fully Compliant	
(CR) 5-20	Fully Compliant	
(CR) 5-21	Not Applicable	The EAGLE does not support automatic backups.
(CR) 5-22	Fully Compliant	
(CR) 5-23	Fully Compliant	
(CR) 5-24	Fully Compliant	
(CR) 5-25	Not Applicable	The EAGLE's database restore does not involve date sensitive data.
(CR) 5-26	Fully Compliant	
(CR) 5-27	Fully Compliant	
(R) 5-28	Fully Compliant	
(R) 5-29	Not Applicable	The EAGLE does not perform delayed activation.
(R) 5-30	Fully Compliant	
(R) 5-31	Fully Compliant	
(R) 5-32	Fully Compliant	
(R) 5-33	Not Applicable	The EAGLE does not perform delayed activation.
(CR) 5-34	Not Applicable	The EAGLE does not perform delayed activation.
(R) 5-35	Fully Compliant	
(R) 5-36	Fully Compliant	
(R) 5-37	Fully Compliant	
(R) 5-38	Fully Compliant	
(R) 5-39	Fully Compliant	
(R) 5-40	Fully Compliant	
(R) 5-41	Fully Compliant	
(R) 5-42	Fully Compliant	

Table 5-39 (Cont.) Section 5. Management Function Areas

Bellcore Requirement	Level of Compliance	Comments/Exceptions
(R) 5-43	Fully Compliant	
(R) 5-44	Fully Compliant	
(R) 5-45	Fully Compliant	
(R) 5-46	Fully Compliant	
(R) 5-47	Fully Compliant	
(R) 5-48	Fully Compliant	
(R) 5-49	Fully Compliant	
(R) 5-50	Not Applicable	The EAGLE does not allow a grace period.
(R) 5-51	Fully Compliant	
(R) 5-52	Fully Compliant	
(R) 5-53	Fully Compliant	
(R) 5-54	Fully Compliant	
(R) 5-55	Fully Compliant	
(R) 5-56	Fully Compliant	
(R) 5-57	Fully Compliant	
(R) 5-58	Fully Compliant	The EAGLE currently does not use cryptography algorithms.
(R) 5-59	Not Applicable	The EAGLE does not have any X.509 applications.
(R) 5-60	Not Applicable	The EAGLE does not have any X.509 applications.
(R) 5-61	Not Applicable	The EAGLE does not have any X.509 applications.
(R) 5-62	Not Applicable	The EAGLE does not have any X.509 applications.
(R) 5-63	Not Applicable	The EAGLE does not have any X.509 applications.
(R) 5-64	Not Applicable	The EAGLE does not have any X.509 applications.
(R) 5-65	Not Applicable	The EAGLE does not have any smart or token card function involving time.

Table 5-40 Section 6. Applications and Functions

Bellcore Requirement	Level of Compliance	Comments/Exceptions
(R) 6-1	Not Applicable	The EAGLE does not have any smart or token card services.
(CR) 6-2	Not Applicable	The EAGLE does not provide this function or application.
(R) 6-3	Not Applicable	The EAGLE does not provide this function or application.
(R) 6-4	Not Applicable	The EAGLE does not provide this function or application.
(R) 6-5	Not Applicable	The EAGLE does not provide this function or application.
(R) 6-6	Not Applicable	The EAGLE does not provide this function or application.
(R) 6-7	Not Applicable	The EAGLE does not provide this function or application.
(R) 6-8	Not Applicable	The EAGLE does not provide this function or application.
(R) 6-9	Not Applicable	The EAGLE does not provide this function or application.

Table 5-40 (Cont.) Section 6. Applications and Functions

Bellcore Requirement	Level of Compliance	Comments/Exceptions
(R) 6-10	Not Applicable	The EAGLE does not provide this function or application.
(R) 6-11	Not Applicable	The EAGLE does not provide this function or application.
(R) 6-12	Not Applicable	The EAGLE does not provide this function or application.
(R) 6-13	Not Applicable	The EAGLE does not provide this function or application.

Table 5-41 Section 7. Process-Oriented Criteria

Bellcore Requirement	Level of Compliance	Comments/Exceptions
(R) 7-1	Fully Compliant	
(R) 7-2	Fully Compliant	
(R) 7-3	Fully Compliant	
(R) 7-4	Fully Compliant	
(R) 7-5	Fully Compliant	
(R) 7-6	Fully Compliant	
(R) 7-7	Fully Compliant	
(R) 7-8	Fully Compliant	
(R) 7-9	Fully Compliant	
(R) 7-10	Fully Compliant	
(R) 7-11	Fully Compliant	
(R) 7-12	Partially Compliant	Tekelec's Quality procedures are used.
(R) 7-13	Fully Compliant	
(R) 7-14	Fully Compliant	
(R) 7-15	Fully Compliant	
(R) 7-16	Fully Compliant	
(R) 7-17	Fully Compliant	
(R) 7-18	Fully Compliant	
(CR) 7-19	Fully Compliant	
(R) 7-20	Fully Compliant	
(R) 7-21	Fully Compliant	
(R) 7-22	Fully Compliant	
(R) 7-23	Fully Compliant	
(R) 7-24	Fully Compliant	
(R) 7-25	Fully Compliant	
(R) 7-26	Fully Compliant	
(R) 7-27	Not Applicable	The EAGLE product uses maintenance releases for software fixes and not patches.

Table 5-41 (Cont.) Section 7. Process-Oriented Criteria

Bellcore Requirement	Level of Compliance	Comments/Exceptions
(R) 7-28	Fully Compliant	
(R) 7-29	Fully Compliant	

Table 5-42 Section 8. System Reliability and Quality Criteria

Bellcore Requirement	Level of Compliance	Comments/Exceptions
(R) 8-1	Not Applicable	The EAGLE will be fully compliant.
(O) 8-2	Not Applicable	The EAGLE will be fully compliant.
(R) 8-3	Not Applicable	The EAGLE will be fully compliant.
(R) 8-4	Not Applicable	The EAGLE will be fully compliant.
(O) 8-5	Not Applicable	The EAGLE will be fully compliant.
(R) 8-6	Not Applicable	The EAGLE will be fully compliant.
(R) 8-7	Fully Compliant	
(O) 8-8	Fully Compliant	The EAGLE conforms to all system reliability and quality criteria as documented by Reliability and Quality Statistics.
(R) 8-9	Fully Compliant	
(O) 8-10	Fully Compliant	The EAGLE conforms to all system reliability and quality criteria as documented by Reliability and Quality Statistics.
(R) 8-11	Fully Compliant	
(O) 8-12	Fully Compliant	The EAGLE conforms to all system reliability and quality criteria as documented by Reliability and Quality Statistics.
(R) 8-13	Fully Compliant	
(O) 8-14	Fully Compliant	The EAGLE conforms to all system reliability and quality criteria as documented by Reliability and Quality Statistics.
(R) 8-15	Fully Compliant	
(O) 8-16	Fully Compliant	
(R) 8-17	Fully Compliant	
(O) 8-18	Fully Compliant	The EAGLE conforms to all system reliability and quality criteria as documented by Reliability and Quality Statistics.
(R) 8-19	Fully Compliant	
(O) 8-20	Fully Compliant	The EAGLE conforms to all system reliability and quality criteria as documented by Reliability and Quality Statistics.
(R) 8-21	Fully Compliant	
(O) 8-22	Fully Compliant	The EAGLE conforms to all system reliability and quality criteria as documented by Reliability and Quality Statistics.
(R) 8-23	Fully Compliant	The EAGLE conforms to all system reliability and quality criteria as documented by Reliability and Quality Statistics.

OAP Year 2000 Compliance

This section lists the software changes that have been made to the **OAP** so that no date-related problems occur on the **OAP** on or after January 1, 2000.

All **OAP** component software has been modified to represent all dates unambiguously according to the date formats shown in *Data Elements and Exchange Formats - Information Exchange - Representation of Dates and Time, ISO 8601, 1998*. All dates that include years but do not currently provide explicit representation of the century have been modified to represent a date according to the calendar date format **YYYYMMDD**. Date and time information in **SEAS** traffic through the **OAP** to the **EAGLE STP** will not have its format modified in the data stream translation. This will ensure compliance with the **SEAS 7.0** standard.

Each year that is divisible by four is a leap year, with the exception of those years that end in "00," such as 1900. The one exception is that years that are divisible by 400 are leap years, such as 1600 and 2000. The **OAP** recognizes the year 2000 as a leap year.

There are three interfaces that cross the boundaries of the **OAP** to external entities. These are **OAP to LSMS**, **OAP to EAGLE**, and **OAP to SEAS**. In instances where a date must be received or transmitted across these boundaries with less than a four-digit year, the **OAP** components have been modified to accept or provide a date that is unambiguous. These modifications have been performed within the confines of **SEAS 7.0** compatibility.

OAP Compliance Matrix

This section lists the Year 2000 requirements, conditional requirements, and objectives that the **OAP** and its components comply with as defined in the Bellcore document, *Year 2000 Generic Requirements: Systems and Interfaces, GR-2945-CORE, Issue 1, BELLCORE, December, 1996*. This section is divided into two parts. The first section details specific compliance requirement areas that pertain to one or more of the **OAP** components. The second section addresses requirements that pertain to the life cycle, quality, and reliability of the system as a whole.

The compliance matrix is a table listing the requirement number, objective number, or conditional requirement number as defined in the Bellcore document, the **OAP's** level of compliance with the requirement, objective, or conditional requirement, and any comments that may apply to these items.

A requirement is a feature or function of the **OAP** that Bellcore has determined must be a part of the **OAP** to function properly. A requirement is identified in this appendix with the letter R in parentheses, (R).

A conditional requirement is a feature or function of the **OAP** that Bellcore has determined is necessary in certain applications, depending on how the **OAP** is deployed. A conditional requirement may depend on other requirements, objectives, or conditional requirements. A conditional requirement is identified in this appendix with the letters **CR** in parentheses, (CR).

An objective is a feature or function of the **OAP** that Bellcore has determined is a desirable feature or function for the **OAP** to have, but not required to have. An objective is identified in this appendix with the letter O in parentheses, (O).

There are four levels of compliance used in this compliance matrix.

- Fully compliant

- Partially compliant
- Not compliant
- Not applicable

The table caption for each table refers to the section of the *Year 2000 Generic Requirements: Systems and Interfaces, GR-2945-CORE, Issue 1, BELLCORE, December, 1996* document where the item can be found.

Table 5-43 Section 2.1. Date-Sensitive Criteria – System Integrity

Bellcore Requirement	Level of Compliance	Comments/Exceptions
(R) 2-1	Not Applicable	No two-digit date representations or usage of <code>tm_yr</code> .
	Fully Compliant	Date reporting is based on Solaris time functions, which use <code>time_t</code> .
(R) 2-2		The Tekelec Installation Utilities and the NEBS alarm daemon do not apply to this requirement. All other OAP components comply with this requirement.
(R) 2-3	Not Applicable	This requirement has been determined to be not applicable by analysis.
(R) 2-4	Fully Compliant	The Tekelec Installation Utilities and the Artecon Arteport kernel level device driver do not apply to this requirement. All other OAP components comply with this requirement.
(R) 2-5	Fully Compliant	
(R) 2-6	Fully Compliant	The Tekelec Installation Utilities do not apply to this requirement. All other OAP components comply with this requirement.

Table 5-44 Section 2.2. Date-Sensitive Criteria – Application Integrity

Bellcore Requirement	Level of Compliance	Comments/Exceptions
(R) 2-7	Fully Compliant	Date/time comparisons, where present, are based on <code>time_t</code> values. The Tekelec Installation Utilities and the Artecon Arteport kernel level device driver do not apply to this requirement. All other OAP components comply with this requirement.
(R) 2-8	Fully Compliant	The Tekelec Installation Utilities, the Artecon Arteport kernel level device driver, and the NEBS alarm daemon do not apply to this requirement. All other OAP components comply with this requirement.
(R) 2-9	Fully Compliant	Only the Tekelec EMS Agent, Tekelec UAL/X25/Disk status refresh and notification daemon , and the NEBS alarm daemon apply to this requirement and fully comply with this requirement. All other OAP components do not apply to this requirement.
(R) 2-10	Not Applicable	The Solaris operating system is responsible for any <code>cron</code> initiated processes.
(R) 2-11	Not Applicable	This requirement has been determined to be not applicable by analysis.

Table 5-44 (Cont.) Section 2.2. Date-Sensitive Criteria – Application Integrity

Bellcore Requirement	Level of Compliance	Comments/Exceptions
(R) 2-12	Not Applicable	This requirement has been determined to be not applicable by analysis.
(R) 2-13	Not Applicable	This requirement has been determined to be not applicable by analysis.
(R) 2-14	Not Applicable	This requirement has been determined to be not applicable by analysis.
	Fully Compliant	All date and time stamps are based on Solaris time calls and contain four digits for the year.
(R) 2-15		The Tekelec Installation Utilities, the Artecon Arteport kernel level device driver, and the NEBS alarm daemon do not apply to this requirement. All other OAP components comply with this requirement.
(R) 2-16	Not Applicable	This requirement has been determined to be not applicable by analysis.
(R) 2-17	Not Applicable	Analysis of the source code has determined that all timers use Solaris <code>time_t</code> values.
(O) 2-18	Not Applicable	This requirement has been determined to be not applicable by analysis.
(R) 2-19	Not Applicable	This requirement has been determined to be not applicable by analysis.
(R) 2-20	Not Applicable	This requirement has been determined to be not applicable by analysis.

Table 5-45 Section 3. User Interface

Bellcore Requirement	Level of Compliance	Comments/Exceptions
(R) 3-1	Not Applicable	This requirement has been determined to be not applicable by analysis.
(R) 3-2	Not Applicable	This requirement has been determined to be not applicable by analysis.
(R) 3-3	Not Applicable	This requirement has been determined to be not applicable by analysis.
(R) 3-4	Not Applicable	This requirement has been determined to be not applicable by analysis.
(O) 3-5	Not Applicable	This requirement has been determined to be not applicable by analysis.
(R) 3-6	Not Applicable	This requirement has been determined to be not applicable by analysis.
(R) 3-7	Not Applicable	The Solaris system clock is used.
(R) 3-8	Not Applicable	The Solaris operating system does use <code>tm_yr</code> values.

Table 5-46 Section 4. Machine-to-Machine Interface

Bellcore Requirement	Level of Compliance	Comments/Exceptions
(O) 4-1	Fully Compliant	<p>The OAP will comply with this requirement if an external communications system uses the ISO 8601 format.</p> <p>Only the Tekelec EMS Agent, Tekelec RS232 Asynchronous Send/Receive daemon, and UAL logical channel over X.25 daemon components apply to this objective and fully comply with this objective.</p> <p>All other OAP components do not apply to this objective.</p>
	Fully Compliant	<p>The OAP will comply with this requirement if an external communications system uses the ISO 8601 format.</p> <p>Only the Tekelec EMS Agent, Tekelec RS232 Asynchronous Send/Receive daemon, and UAL logical channel over X.25 daemon components apply to this objective and fully comply with this objective.</p> <p>All other OAP components do not apply to this objective.</p>
(O) 4-2	Fully Compliant	<p>ASN.1 (X.208) is used.</p> <p>Only the Tekelec EMS Agent applies to this requirement and fully complies with this requirement.</p> <p>All other OAP components do not apply to this requirement.</p>
	Fully Compliant	<p>For information that OAP stores and processes as date field information, SEAS protocol or ASN.1 (X.208) is used.</p> <p>Only the Tekelec EMS Agent, Tekelec RS232 Asynchronous Send/Receive daemon, and Bellcore UAL logical channel over X.25 daemon components apply to this conditional requirement and fully comply with this conditional requirement.</p> <p>All other OAP components do not apply to this conditional requirement.</p>
(R) 4-3	Fully Compliant	<p>For information that OAP stores and processes as date field information, SEAS protocol or ASN.1 (X.208) is used.</p> <p>Only the Tekelec EMS Agent, Tekelec RS232 Asynchronous Send/Receive daemon, and Bellcore UAL logical channel over X.25 daemon components apply to this conditional requirement and fully comply with this conditional requirement.</p> <p>All other OAP components do not apply to this conditional requirement.</p>
	Fully Compliant	<p>For information that OAP stores and processes as date field information, SEAS protocol or ASN.1 (X.208) is used.</p> <p>Only the Tekelec EMS Agent, Tekelec RS232 Asynchronous Send/Receive daemon, and Bellcore UAL logical channel over X.25 daemon components apply to this conditional requirement and fully comply with this conditional requirement.</p> <p>All other OAP components do not apply to this conditional requirement.</p>
(CR) 4-4	Fully Compliant	<p>For information that OAP stores and processes as date field information, SEAS protocol or ASN.1 (X.208) is used.</p> <p>Only the Tekelec EMS Agent, Tekelec RS232 Asynchronous Send/Receive daemon, and Bellcore UAL logical channel over X.25 daemon components apply to this conditional requirement and fully comply with this conditional requirement.</p> <p>All other OAP components do not apply to this conditional requirement.</p>
	Fully Compliant	<p>For information that OAP stores and processes as date field information, SEAS protocol or ASN.1 (X.208) is used.</p> <p>Only the Tekelec EMS Agent, Tekelec RS232 Asynchronous Send/Receive daemon, and Bellcore UAL logical channel over X.25 daemon components apply to this conditional requirement and fully comply with this conditional requirement.</p> <p>All other OAP components do not apply to this conditional requirement.</p>
(CR) 4-5	Fully Compliant	<p>For information that OAP stores and processes as date field information, SEAS protocol or ASN.1 (X.208) is used.</p> <p>Only the Tekelec EMS Agent, Tekelec RS232 Asynchronous Send/Receive daemon, and Bellcore UAL logical channel over X.25 daemon components apply to this conditional requirement and fully comply with this conditional requirement.</p> <p>All other OAP components do not apply to this conditional requirement.</p>
	Fully Compliant	<p>For information that OAP stores and processes as date field information, SEAS protocol or ASN.1 (X.208) is used.</p> <p>Only the Tekelec EMS Agent, Tekelec RS232 Asynchronous Send/Receive daemon, and Bellcore UAL logical channel over X.25 daemon components apply to this conditional requirement and fully comply with this conditional requirement.</p> <p>All other OAP components do not apply to this conditional requirement.</p>
(CR) 4-6	Fully Compliant	<p>For information that OAP stores and processes as date field information, SEAS protocol or ASN.1 (X.208) is used.</p> <p>Only the Tekelec EMS Agent, Tekelec RS232 Asynchronous Send/Receive daemon, and Bellcore UAL logical channel over X.25 daemon components apply to this conditional requirement and fully comply with this conditional requirement.</p> <p>All other OAP components do not apply to this conditional requirement.</p>
	Fully Compliant	<p>For information that OAP stores and processes as date field information, SEAS protocol or ASN.1 (X.208) is used.</p> <p>Only the Tekelec EMS Agent, Tekelec RS232 Asynchronous Send/Receive daemon, and Bellcore UAL logical channel over X.25 daemon components apply to this conditional requirement and fully comply with this conditional requirement.</p> <p>All other OAP components do not apply to this conditional requirement.</p>

Table 5-46 (Cont.) Section 4. Machine-to-Machine Interface

Bellcore Requirement	Level of Compliance	Comments/Exceptions
	Fully Compliant	For information that OAP stores and processes as date field information, SEAS protocol or ASN.1 (X.208) is used. Only the Tekelec EMS Agent, Tekelec RS232 Asynchronous Send/Receive daemon , and Bellcore UAL logical channel over X.25 daemon components apply to this conditional requirement and fully comply with this conditional requirement. All other OAP components do not apply to this conditional requirement.
(CR) 4-7		
(R) 4-8	Not Applicable	This requirement has been determined to be not applicable by analysis.
(R) 4-9	Not Applicable	This requirement has been determined to be not applicable by analysis.
(R) 4-10	Not Applicable	This requirement has been determined to be not applicable by analysis.
(R) 4-11	Not Applicable	This requirement has been determined to be not applicable by analysis.
(R) 4-12	Not Applicable	This requirement has been determined to be not applicable by analysis.
(R) 4-13	Not Applicable	This requirement has been determined to be not applicable by analysis.

Table 5-47 Section 5. Management Functional Areas

Bellcore Requirement	Level of Compliance	Comments/Exceptions
(R) 5-1	Not Applicable	This requirement only applies to the Solaris operating system.
(R) 5-2	Not Applicable	This requirement only applies to the Solaris license manager.
(CR) 5-3	Not Applicable	No configuration data reporting is provided that is dependent on the start-date/time for the collection determined by analysis.
(CR) 5-4	Not Applicable	This requirement has been determined to be not applicable by analysis.
(CR) 5-5	Not Applicable	This requirement has been determined to be not applicable by analysis.
(CR) 5-6	Not Applicable	The analysis of the source code determined that there is no configuration data change that is scheduled by date/time.
(CR) 5-7	Not Applicable	This requirement has been determined to be not applicable by analysis.
(R) 5-8	Not Applicable	All dates reported are based on the Sparc 5 system clock.
(R) 5-9	Not Applicable	All dates reported are based on the Sparc 5 system clock.
(CR) 5-10	Not Applicable	This conditional requirement has been determined to be not applicable by analysis.

Table 5-47 (Cont.) Section 5. Management Functional Areas

Bellcore Requirement	Level of Compliance	Comments/Exceptions
(R) 5-11	Fully Compliant	Only the Tekelec EMS Agent and Bellcore UAL logical channel over X.25 daemon components apply to this requirement and fully comply with this requirement. All other OAP components do not apply to this requirement.
(R) 5-12	Fully Compliant	Only the Tekelec EMS Agent and Bellcore UAL logical channel over X.25 daemon components apply to this requirement and fully comply with this requirement. All other OAP components do not apply to this requirement.
(CR) 5-13	Not Applicable	This conditional requirement has been determined to be not applicable by analysis.
(CR) 5-14	Not Applicable	This conditional requirement has been determined to be not applicable by analysis.
(CR) 5-15	Not Applicable	This conditional requirement has been determined to be not applicable by analysis.
(CR) 5-16	Not Applicable	This conditional requirement has been determined to be not applicable by analysis.
(CR) 5-17	Not Applicable	This conditional requirement has been determined to be not applicable by analysis.
(O) 5-18	Not Applicable	This objective has been determined to be not applicable by analysis.
(CR) 5-19	Not Applicable	This conditional requirement has been determined to be not applicable by analysis.
(CR) 5-20	Not Applicable	This conditional requirement has been determined to be not applicable by analysis.
(CR) 5-21	Not Applicable	This conditional requirement has been determined to be not applicable by analysis.
(CR) 5-22	Not Applicable	This conditional requirement has been determined to be not applicable by analysis.
(CR) 5-23	Not Applicable	This conditional requirement has been determined to be not applicable by analysis.
(CR) 5-24	Not Applicable	This conditional requirement has been determined to be not applicable by analysis.
(CR) 5-25	Not Applicable	This conditional requirement has been determined to be not applicable by analysis.
(R) 5-26	Fully Compliant	The system software download is performed as part of the installation process, which is manually initiated and is performed on demand. Only the Tekelec installation utility applies to this requirement and fully complies with this requirement. All other OAP components do not apply to this requirement.
(R) 5-27	Fully Compliant	Only the Tekelec installation utility applies to this requirement and fully complies with this requirement. All other OAP components do not apply to this requirement.

Table 5-47 (Cont.) Section 5. Management Functional Areas

Bellicore Requirement	Level of Compliance	Comments/Exceptions
	Fully Compliant	Per Tekelec upgrade procedure using trial/approved nondestructive upgrade procedures.
(R) 5-28		Only the Tekelec installation utility applies to this requirement and fully complies with this requirement. All other OAP components do not apply to this requirement.
(R) 5-29	Not Applicable	This requirement has been determined to be not applicable by analysis.
(R) 5-30	Not Applicable	Dependent on the Sparc 5 system clock and Solaris date/time functions.
(R) 5-31	Not Applicable	This requirement is for network traffic management.
(R) 5-32	Not Applicable	This requirement is for network traffic management.
(R) 5-33	Not Applicable	This requirement has been determined to be not applicable by analysis.
(CR) 5-34	Not Applicable	This conditional requirement has been determined to be not applicable by analysis.
(R) 5-35	Not Applicable	This requirement has been determined to be not applicable by analysis.
(R) 5-36	Not Applicable	This requirement has been determined to be not applicable by analysis.
(R) 5-37	Not Applicable	This requirement has been determined to be not applicable by analysis.
(R) 5-38	Not Applicable	This requirement only applies to the Solaris operating system.
(R) 5-39	Not Applicable	This requirement only applies to the Solaris operating system.
(R) 5-40	Not Applicable	Password aging is handled by the Solaris operating system.
(R) 5-41	Not Applicable	Notification of password expiration is handled by the Solaris operating system.
(R) 5-42	Not Applicable	Password updates are handled by the Solaris operating system.
(R) 5-43	Not Applicable	All process tracking is handled by the Solaris operating system.
(R) 5-44	Not Applicable	All process tracking is handled by the Solaris operating system.
(R) 5-45	Not Applicable	File creation dates are handled by the Solaris operating system.
(R) 5-46	Not Applicable	This requirement has been determined to be not applicable by analysis.
(R) 5-47	Not Applicable	All time stamps are the results of Solaris calls and use four-digit dates for the year.
(R) 5-48	Not Applicable	This requirement applies to the Solaris operating system.
(R) 5-49	Not Applicable	This requirement applies to the Solaris operating system.
(R) 5-50	Not Applicable	This requirement applies to the Solaris operating system.

Table 5-47 (Cont.) Section 5. Management Functional Areas

Bellcore Requirement	Level of Compliance	Comments/Exceptions
(R) 5-51	Fully Compliant	Only the Tekelec EAGLE REPT-UIM autonomous event report daemon and the NEBS alarm daemon components apply to this requirement and fully complies with this requirement. All other OAP components do not apply to this requirement. Also applies to the Solaris operating system.
(R) 5-52	Not Applicable	This requirement applies to the Solaris operating system.
(R) 5-53	Not Applicable	This requirement applies to the Solaris operating system.
(R) 5-54	Not Applicable	The Solaris operating system is responsible for this security authentication requirement.
(R) 5-55	Not Applicable	The Solaris operating system is responsible for this security authentication requirement.
(R) 5-56	Not Applicable	The Solaris operating system is responsible for this security authentication requirement.
(R) 5-57	Not Applicable	This requirement has been determined to be not applicable by analysis.
(R) 5-58	Not Applicable	
(R) 5-59	Not Applicable	This requirement has been determined to be not applicable by analysis.
(R) 5-60	Not Applicable	This requirement has been determined to be not applicable by analysis.
(R) 5-61	Not Applicable	This requirement has been determined to be not applicable by analysis.
(R) 5-62	Not Applicable	This requirement has been determined to be not applicable by analysis.
(R) 5-63	Not Applicable	This requirement has been determined to be not applicable by analysis.
(R) 5-64	Not Applicable	This requirement has been determined to be not applicable by analysis.
(R) 5-65	Not Applicable	This requirement has been determined to be not applicable by analysis.

Table 5-48 Section 6. Applications and Functions

Bellcore Requirement	Level of Compliance	Comments/Exceptions
(R) 6-1	Not Applicable	This requirement has been determined to be not applicable by analysis.
(CR) 6-2	Not Applicable	This requirement has been determined to be not applicable by analysis.
(R) 6-3	Not Applicable	This requirement has been determined to be not applicable by analysis.
(R) 6-4	Not Applicable	This requirement has been determined to be not applicable by analysis.

Table 5-48 (Cont.) Section 6. Applications and Functions

Bellcore Requirement	Level of Compliance	Comments/Exceptions
(R) 6-5	Not Applicable	This requirement has been determined to be not applicable by analysis.
(R) 6-6	Not Applicable	This requirement has been determined to be not applicable by analysis.
(R) 6-7	Not Applicable	This requirement has been determined to be not applicable by analysis.
(R) 6-8	Not Applicable	This requirement has been determined to be not applicable by analysis.
(R) 6-9	Not Applicable	This requirement has been determined to be not applicable by analysis.
(R) 6-10	Not Applicable	This requirement has been determined to be not applicable by analysis.
(R) 6-11	Not Applicable	This requirement has been determined to be not applicable by analysis.
(R) 6-12	Not Applicable	This requirement has been determined to be not applicable by analysis.
(R) 6-13	Not Applicable	This requirement has been determined to be not applicable by analysis.

OAP System Compliance

The remaining two sections of **GR-2945-CORE** deal with Process-Oriented Criteria and System Reliability and Quality Criteria. Each of these requirements has been evaluated for applicability and compliance on system/program level for the **OAP**.

Table 5-49 Section 7. Process-Oriented Criteria

Bellcore Requirement	Level of Compliance	Comments/Exceptions
(R) 7-1	Fully Compliant	
(R) 7-2	Fully Compliant	
(R) 7-3	Fully Compliant	
(R) 7-4	Fully Compliant	
(R) 7-5	Fully Compliant	
(R) 7-6	Fully Compliant	
(R) 7-7	Fully Compliant	
(R) 7-8	Fully Compliant	
(R) 7-9	Fully Compliant	
(R) 7-10	Fully Compliant	
(R) 7-11	Fully Compliant	
(R) 7-12	Partially Compliant	Tekelec's Quality Procedures are used.
(R) 7-13	Fully Compliant	

Table 5-49 (Cont.) Section 7. Process-Oriented Criteria

Bellcore Requirement	Level of Compliance	Comments/Exceptions
(R) 7-14	Fully Compliant	
(R) 7-15	Fully Compliant	
(R) 7-16	Fully Compliant	
(R) 7-17	Fully Compliant	
(R) 7-18	Fully Compliant	
(CR) 7-19	Fully Compliant	
(R) 7-20	Fully Compliant	
(R) 7-21	Fully Compliant	
(R) 7-22	Fully Compliant	
(R) 7-23	Fully Compliant	
(R) 7-24	Fully Compliant	
(R) 7-25	Fully Compliant	
(R) 7-26	Fully Compliant	
(R) 7-27	Fully Compliant	OAP updates are only performed by updates, not be patches
(R) 7-28	Fully Compliant	
(R) 7-29	Fully Compliant	

Table 5-50 Section 8. System Reliability and Quality Criteria

Bellcore Requirement	Level of Compliance	Comments/Exceptions
(R) 8-1	Fully Compliant	
(O) 8-2	Fully Compliant	
(R) 8-3	Fully Compliant	
(R) 8-4	Not Applicable	This requirement has been determined to be not applicable by analysis.
(O) 8-5	Not Applicable	This objective has been determined to be not applicable by analysis.
(R) 8-6	Not Applicable	This requirement has been determined to be not applicable by analysis.
(R) 8-7	Fully Compliant	
(O) 8-8	Fully Compliant	
(R) 8-9	Fully Compliant	
(O) 8-10	Fully Compliant	
(R) 8-11	Fully Compliant	
(O) 8-12	Fully Compliant	
(R) 8-13	Fully Compliant	
(O) 8-14	Fully Compliant	

Table 5-50 (Cont.) Section 8. System Reliability and Quality Criteria

Bellcore Requirement	Level of Compliance	Comments/Exceptions
(R) 8-15	Fully Compliant	
(O) 8-16	Fully Compliant	
(R) 8-17	Fully Compliant	
(O) 8-18	Fully Compliant	
(R) 8-19	Fully Compliant	
(O) 8-20	Fully Compliant	
(R) 8-21	Fully Compliant	
(O) 8-22	Fully Compliant	
(R) 8-23	Fully Compliant	

6

EMS Features

This chapter describes features associated with EAGLE Element Management System (EMS).

6.1 Command Manager Interface Enhancements (EMS 40.0)

The following enhancements have been added to the Command Manager Interface (CMI), which was previously known as the Configuration Management Interface.

- **CMI Administration**
EMS Users must log in to the CMI with a user name and password in order to use the Command Manager Interface. EMS Users using the CMI can be designated as CMI Administrators. A CMI Administrator is defined to have access to all CMI functions and EAGLE 5 ISS commands supported by the Command Manager Interface. EMS Users who belong to the NetBoss Administrator group are automatically designated as CMI Administrators.

To accomplish this access control the following enhancements have been added to the CMI.

- **CMI User Groups**
CMI Administrators define "User Groups" that are associated with subsets of CMI functions and EAGLE 5 ISS commands. CMI Administrators then associate each EMS User with a particular User Group according to the roles and appropriate access rights for that EMS User. The Command Manger Interface ensures that EMS Users only use the commands and functions associated with that User Group.
- **EAGLE 5 ISS Command Access Control**
EMS Users are only permitted to use EAGLE 5 ISS commands that they have been specifically authorized to use (according to CMI User Group). CMI Administrators can define CMI Command Classes, which contain subsets of EAGLE 5 ISS commands. These, in addition to the standard EAGLE 5 ISS Command classes, are associated with CMI User Groups in order to control the EAGLE 5 ISS commands to which an EMS User has access.

Before sending a command to an EAGLE 5 ISS for execution or saving a command in a CMI command script, the Command Manager Interface ensures that the EMS User is authorized to use that command.

- **CMI Function Access Control**
EMS Users are only permitted to use the CMI functions that they have been specifically authorized to use (according to CMI User Group). CMI functions include the following:
 - * Sending commands
 - * Managing CMI command scripts
 - * Defining Categories of CMI command scripts
 - * Scheduling CMI command script execution and viewing the results
 - * Viewing logs of CMI activities

- * Performing CMI Administrator tasks
- CMI Command Completion and Selection
When menus are used to build EAGLE 5 ISS commands, only the permitted commands will be presented. EMS Users can further refine the list of commands that are presented by selecting a command class, causing only the commands belonging to that command class to be listed.

Additionally, a command "search" capability is provided that facilitates quick selection of a desired EAGLE 5 ISS command. The EMS User begins typing the name of the command and the Command Manger Interface will provide the command that most closely matches the characters as they are typed.

Once a command is selected, the EMS User can "Get Parameters", which causes the Command Manager Interface to present the parameters defined for that command. Parameter values can be selected from drop-down lists by selecting the first character of the desired value.
- CMI Parameter Save
The Command Manager Interface stores the most-recent 20 EAGLE commands built during an EMS User session. On request, the most recently used commands and parameter values are presented in order to expedite the entry of similar commands.
- CMI Free Command Edit
In addition to building EAGLE 5 ISS commands using menus, EMS Users have the option of entering the command directly. The Command Manager Interface ensures that the EMS User is a member of a User Group that was authorized to use this command before sending it to a EAGLE 5 ISS or saving the CMI command script that contains the command.
- EAGLE 5 ISS Release 40.0 Command Set Support
The Command Manager Interface supports all of the commands defined for the EAGLE 5 ISS Release 40.0 except for those belonging to the EAGLE 5 ISS "debug" command class, those commands requiring a password, and the logout command.
- CMI Support for Multiple Eagles
EMS Users have the ability to login on multiple EAGLE systems and send a command to all of those systems.
- CMI Command Script Enhancements
EMS Users can define categories to classify their CMI command scripts and assign their own scripts to those categories. CMI Administrators can view, modify, delete, and schedule the execution of CMI command scripts created by all EMS Users. EMS Users who are not CMI Administrators can only access their own CMI command scripts.
- Password Management
EMS Users must log in to the CMI using a user name and password. Both CMI Administrators and EMS Users can change that password.

6.2 Command Manager Interface (EMS 43.0)

The Command Manager Interface provides access to EAGLE 5 commands and parameters.

Enhancements to this interface include:

- [Password Security](#)

- [Script Results Enhancements](#)
- [Add History To Search Command Box](#)

Password Security

CMI password management and the security of user logins are strengthened. Some security constraints will be the same for all users while some constraints are configurable separately for CMI Administrators and non-administrators. These enhancements include:

- **Password Composition Management**
Password security is strengthened by making the user password more complex. Rules can be configured to ensure user password complexity. Enforcement of password composition constraints on CMI users is configurable.

Also provided is restricting the number of previously used passwords for a user that cannot be reused as new passwords and configuration of a minimum password change interval for CMI users.
- **Password Change Management**
Password expiration aging and notification are configurable.
- **Login Restrictions Management**
These enhancements are provided to manage user-account information.
 - When a user password has been set/reset, the user will be required to change password to continue login to the CMI.
 - The maximum permissible number of wrong login attempts that can be made by a CMI user is now configurable. The user account exceeding the attempts will be locked. A user whose account has been locked will not be allowed to login to the CMI and an attempt to do so will result in an error message.
 - A maximum permissible inactivity period (in minutes) after which user will be logged out of the CMI is now configurable. The logged-out user will be allowed to login again immediately to the CMI.
 - CMI Administrators can now configure whether or not multiple users can log into the CMI using the same user name.
 - CMI Administrators can now revoke a user's login rights (except NetBoss Administrators and CMI users that are not associated with any usergroup).
 - User account information (such as status of a user (revoked/locked/expired), number of unsuccessful login attempts, number of wrong login attempts, last successful login date and log-out time) is maintained by the CMI.
- **User Account Recovery**
CMI Administrators can now reactivate a user account that was locked or revoked.
- **CMI Activity Logging**
All configuration changes and security events resulting from the enforcement of the security enhancements provided in Release 43.0 will be logged by the CMI.

Script Results Enhancements

This enhancement provides the CMI user a better experience in viewing the results of command and script executions.execution and management of script results. This enhancement on the CMI It is being implemented as an extension to the existing CMI **Send Command** and **Execute Script** functions.including resultant file management.

For these enhancements, the most recent 5000 lines of results are presented on the **Execute Script** and **Send Command** pages on the respective **Results** panes.

With this enhancement, the most recent 5000 lines of results are presented on the **Send Command** page in the **Results** pane. The most recent 1500 lines of ad-hoc script execution results are presented on the **Execute Script** page on the **Results** pane.

In addition, a separate new browser window is provided where the user is able to view command and script execution result data. The new browser window pane will display up to 500,000 lines of the most recent results.

In addition, new browser windows are provided, in which the user can view command and script-execution result data. For the command results, the new browser window will display up to 500,000 lines of the most recent results for commands sent during the current User session. For script results, the new browser window will display up to 500,000 lines of results from the most recent script execution, whether that script execution was scheduled or ad-hoc.

In the case of script results, this window will display the results of the most recent **Execute Script** (either scheduled or ad-hoc execution). Each ad-hoc and scheduled execution of a command script will replace the previous result data stored in the corresponding result file with the new execution result data.

In the case of **Send Command** results, this window will display the most recent results of all of the commands run in the current login session - up to 500,000 lines.

Add History To Search Command Box

This enhancement to the existing **Search Command** functionality, in the **Build Commands** pane of the **Send Command/Create Script/Modify Script** pages, enables a user to view the latest 20 command search strings entered by the user in a particular user session.

A suggestion box displaying previously entered search strings will be displayed below the **Search Command** box. Up to 20 of the most recent search strings entered during the current user session are available. As the user types more characters, the list of suggested search strings will be refined accordingly.

6.3 Command Manager Interface Enhancements - Command Scripts (EMS 41.0)

CMI Command Script Validation

The **Command Manager Interface (CMI)** has been enhanced to include improved verification of CMI command scripts to ensure that they meet the access constraints dictated by the EMS Usergroup to which the EMS User using the script belongs.

- CMI command scripts must only use EAGLE 5 commands and access EAGLE 5 systems that the EMS User using that script has been authorized to use, as specified by the associated CMI Usergroup.
- To allow CMI command scripts to be validated for access control rights, variable substitutions for EAGLE 5 command names and CLLI parameters are no longer permitted in CMI command scripts. Literal strings must be used instead. For example,

```
send_command($command, $CLLI);
```

must be written as

```
send_command("rtrv-sid","stpa");
```

and

```
send_login($CLLI);
```

must be written as

```
send_login("stpa");
```

 **Note:**

CMI command scripts that are created, modified, and/or executed by either CMI Administrators or EMS Users associated with a CMI Usergroup that allows access to all EAGLE 5 commands and all EAGLE 5 systems are not validated in this way as described in [Legacy CMI Command Script Support](#).

Legacy CMI Command Script Support

To improve support of legacy CMI command scripts, the following changes have been implemented:

- In addition to alphanumeric characters (a-z, A-Z, 0-9) previously allowed in CMI command script names, the character set has been enlarged to include underscores (_), hyphens (-), and periods(.). The first character in the script name must be an alpha character (a-z, A-Z).
- The CMI command scripts created, modified, and/or executed by CMI Administrators are not checked for validity as described in [CMI Command Script Validation](#).
- The CMI command scripts created, modified, and/or executed by EMS Users that are authorized to use all EAGLE 5 commands and access all EAGLE 5 systems to which the EAGLE EMS is connected are not checked for validity as described in [CMI Command Script Validation](#).

 **Note:**

EMS Users can be prevented from creating new CMI command scripts or modifying legacy CMI command scripts by associating them with a CMI Usergroup that does not allow those Functions. If that CMI Usergroup allows CMI command script execution, those EMS Users would be able to execute legacy CMI command scripts.

6.4 Command Manager Interface Enhancements - Controlling Access to Individual EAGLE 5 Systems (EMS 41.0)

The Command Manager Interface **User Group** definition has been expanded to allow **CMI Administrators** to specify the set of EAGLE 5 systems that can be accessed by **EMS Users** assigned to that **CMI User Group**. EMS Users are presented with the list of EAGLE 5 systems to which they have been granted access when using the following Command Manager Interface functions:

- Send Command
- Create Script
- Modify Script
- Execute Script

If an EMS User attempts to access an EAGLE 5 system to which they have not been granted access, an error message is displayed and the access is denied.

6.5 Command Manager Interface Enhancements - User Activity Logging (EMS 41.0)

The **Command Manager Interface (CMI)** has been enhanced to log **EMS User** activities, including those that affect EAGLE systems and those within the Command Manager Interface itself. **Current Logs** and **Log Files** allow **CMI Administrators** to monitor all EMS User activity in the **CMI** as follows:

- **Current Logs:**
User activities of the last 24 hours are accessed in **Current Logs**. Each entry contains the following information about a specific EMS User activity within the CMI:
 - Date and Time of activity
 - Name of EMS User performing activity
 - Activity Area of activity (e.g., login, run script, script management, administration)
 - Type (indicates whether the activity affected an **EAGLE 5** system or not)
 - Description of the action

This information is presented in tabular form and the log can be sorted on the date/time, EMS User name, Activity area, or Type columns. The number of records to be displayed per page can be selected, ranging from 10 to 1000 records on each page.

- **Log Files:**
User activities older than those presented in **Current Logs** and newer than 15 days old, are accessed in **Log Files**. Two separate files are saved for each date:
 - EAGLE Affecting Logs

These logs contain records of EMS User activities that affect EAGLE 5 systems, including sending commands and running scripts.

- User Action Logs
These logs contain records of EMS User activities within the Command Manager Interface that do not directly affect EAGLE 5 systems, such as logging in to the CMI, creating and executing CMI Command Scripts, and CMI administrative activities.

Each entry contains the following information about a specific EMS User activity within the CMI:

- Date and Time of activity
- Name of EMS User performing activity
- Activity Area of activity (e.g., login, run script, script management, administration)
- Description of the action

This information is presented as a flat file in chronological order of the activities.

After 15 days, **Log Files** are archived.

6.6 Enhanced SNMP Northbound Interface (EMS 41.0)

The Enhanced SNMP Northbound Interface enables **EAGLE 5 EMS** to process all of the alarms it receives and forward them to a registered **Network Management System** as **SNMPv1** (Simple Network Management Protocol, version 1) traps. Additionally, a new mechanism is provided for resynchronizing all open alarms between the Network Management System and the EAGLE 5 EMS system on request from the Network Management System.

Upon receiving a resynchronization request from a network management system, EAGLE 5 EMS will

1. Halt normal forwarding of alarms to the requesting network management system and queue all incoming alarms for later forwarding.
2. Send all existing open alarms to the network management system, along with an indication that they are part of a resynchronization operation.
3. Forward alarms that were queued beginning in Step 1.

In this way, open alarms are synchronized between the EAGLE 5 EMS and the network management system.

Enhanced SNMP Northbound Interface Performance

The expected throughput of the Enhanced SNMP Northbound Interface, based on the number of EAGLE 5 systems, is shown in [Table 6-1](#).

Table 6-1 Enhanced SNMP Northbound Interface Expected Load

EMS Tier	Number of EAGLE 5 Pairs	Forwarding Throughput (Alarms/Second)
1	Up to 2 pair	16
2	Up to 6 pair	48
3	Up to 10 pair	80
4	Up to 14 pair	112

6.7 Enhanced SNMP Northbound Interface (EMS 42.0)

The Enhanced SNMP Northbound Interface enables **EAGLE 5 EMS** to process all of the alarms it receives and forward them to a registered **Network Management System** (NMS). Additionally, a mechanism is provided for resynchronizing all open alarms between the Network Management System and the EAGLE 5 EMS system on request from the Network Management System.

Enhancements to this interface include:

- Support of SNMP v2 traps
- The number of simultaneous resynchronizations is configurable.
- Reason code added to resynchronization request reject Trap.
- Reason code added to resynchronization request stop Trap.
- When a secondary EMS server becomes the primary, the new primary EMS server transmits a notification trap to all northbound NMS. This trap can be used by each new primary NMS to trigger a resync operation, thus ensuring that the NMS is aware of all the current outstanding alarms.
- The ResyncStop trap has been realigned to allow the NMS to recognize the end of outstanding alarm resynchronization and the beginning of autonomous alarm transmission.

6.8 Fault/Communication Agent (EMS 43.0)

The Fault/Communication Agent manages all required communication between EAGLE 5 systems and the EAGLE EMS system.

This enhancement provides extended idle timeouts for selected EAGLE 5 commands, in order to accommodate EAGLE 5 processing time required for those commands.

The following commands have had their default timeouts extended in this release (`rtrv-seculog`, `rtrv-log`, and `chg-db`).



Note:

If required, please contact for assistance in changing timeouts for other EAGLE system commands.

6.9 Historical Event Viewer (HEV) (EMS 43.0)

The use of a GENERAL type terminal with minimum group setting allows EAGLE 5 UIMs to be captured by the EAGLE EMS and displayed in the Historical Event Viewer. The user is able to apply HEV filters to view only selected UIMs based on the filter selection of the named titles in the event.

UIMs are considered transient and are not persisted in the events database .

6.10 HTTPS Access for EAGLE EMS CMI (EMS 44.0)

The HTTPS Access for Eagle EMS CMI feature provide HTTPS access through secure port 3443 as an option for connecting with the EAGLE EMS Command Manager Interface (CMI). Currently EAGLE EMS CMI is accessed through HTTP on port 3000, which is not secure.

HTTPS uses encryption to secure Internet traffic and protect Internet traffic from snooping or tampering by others on the network. HTTPS uses Secure Sockets Layer (SSL), which is used to encrypt the data stream between the Web server and the Web client (browser). This will improve security and secure the traffic running over internet. A Secure Sockets Layer (SSL) certificate must be installed on the server to increase the security and authenticate the communicating party.

6.11 Link Utilization Interface (EMS 42.0)

The Link Utilization interface collects and stores link capacity information about EAGLE 5 signaling links into the EAGLE EMS database. That capacity data is used by the EAGLE EMS to create informative Measurement Reports about the utilization of links for which the EAGLE 5 is an endpoint.

Enhancements to this interface include:

- Link Capacity data shall be persisted for a configurable amount of time (default 30 days).

Note:

This will support the production of per-link capacity trend reports, historical capacity reports, and historical utilization reports created by mating persisted measurement data with historical capacity reports.

- Link Utilization Crystal Reports
 - **Link Utilization Report:** contains utilization and erlang values for Links for which EAGLE 5 is an endpoint
 - **Linkset Utilization Report:** contains utilization and erlang values for Linksets for which EAGLE 5 is an endpoint
 - **Card Utilization Report:** contains utilization values for EAGLE 5 cards

6.12 LUI Measurements Thresholding (EMS 44.0)

The LUI Measurements Thresholding feature is an enhancement of the existing LUI module by providing alarm thresholds based on the percent occupancy of links during each reporting period configured on EAGLEs. The LUI Measurements Thresholding feature provides thresholding functions on the Link Utilization Interface (LUI) performance management indicators. These thresholding functions include the configuration of breach and abatement thresholds, the monitoring and comparison of percent utilization values to configured thresholds, and the performance of specified actions upon crossing configured thresholds, including the generation and clearing of threshold alarms.

EAGLE EMS receives performance data from EAGLEs at regular intervals. The Performance Reporting Agent (Measurements Platform) collects the performance data. The collected

performance data is parsed and stored in the EAGLE EMS database table `TEK_MEAS_COMP_LINK`. The EAGLE EMS LUI module gathers and calculates link, linkset, and card capacity information from EAGLEs and stores this information in the EAGLE EMS database table `TEKELEC_SLK_CAPACITY`.

Using this capacity information along with the measurements gathered from EAGLEs, the LUI Measurements Thresholding feature calculates percent utilization for all the entities of the type link, linkset, and card. LUI Measurements Thresholding allows configuration of thresholds by link, linkset, and card measurement types. For each measurement type, the threshold alarm value, alarm severity, and threshold clear value can be configured independently from the other measurement types.

Figure 6-1 LUI Measurements Thresholding Configuration

<input checked="" type="checkbox"/> Enable All	Measurement Type	Threshold Alarm Value	Severity Level	Threshold Clear Value
<input checked="" type="checkbox"/>	LINK	50 %	Critical ▾	45 %
<input checked="" type="checkbox"/>	LINKSET	50 %	Major ▾	45 %
<input checked="" type="checkbox"/>	CARD	50 %	Minor ▾	45 %

7

E5-MS/OCEEMS Features

This chapter describes features associated with EAGLE Element Management System (E5-MS) and Oracle Communications EAGLE Element Management System (OCEEMS).

7.1 Add Command History in EMS CMI for each user (Release 46.3)

This feature provides Command Manager Interface (CMI) users the ability to access the last N commands executed in the CMI Send Command screen. The command history for the last N commands is provided for the **Type Command** pane on the **Send Command** screen.

The default value of command history size is 30. This value is configurable through the `commandHistorySize` parameter in the `/Tekelec/WebNMS/conf/tekelec/CmiParameters.conf` file.

See *Interface User's Guide* for more information.

7.2 Architecture (E5-MS 45.0)

The new E5-MS product is available in a tiered architecture using the following configurations:

- Small:
 - up to 4 Network Elements (2 STP pairs)
 - up to 5 concurrent Users
- Medium:
 - up to 20 Network Elements (10 STP pairs)
 - up to 15 concurrent Users
- Large:
 - up to 50 Network Elements (25 STP pairs)
 - up to 25 concurrent Users

A redundant E5-MS system can be delivered as an option (in a mated pair architecture: active/standby architecture). The redundant architecture includes:

- Data and alarm synchronization between the two systems
- Fail over from active system to standby system
- Switch back to the primary site
- Configuration information and dynamic states (such as, alarms and statistics) will be synchronized between primary and secondary sites

Hardware and Operational System (OS) Requirements

The end user interface is based on a Java client interface and is supported by Internet Explorer 8 and above or Mozilla Firefox 16 and above browsers. The E5-MS requirements are as follows:

- Small System
 - CPU at 2GHz minimum - 1 CPU system supported
 - Memory 2GB or higher - 8 GB recommended
 - Disk space, a minimum of 400MB for software installation (of which 200MB is reserved for swap), however 500GB SAS disks are recommended. (for database and history requirements)
- Medium System
 - CPU at 2GHz minimum - 1 CPU system supported
 - Memory 4GB or higher - 8 GB recommended
 - Disk space, a minimum of 400MB for software installation (of which 200MB is reserved for swap), however 500GB SAS disks are recommended. (for database and history requirements)
- Large System
 - CPU at 2GHz minimum - 1 CPU system supported
 - Memory 8GB or higher - 16GB recommended
 - Disk space, a minimum of 400MB for software installation (of which 200MB is reserved for swap), however 500GB SAS disks are recommended. (for database and history requirements)

E5-MS application requires Linux 64 bit Operating Systems. It is developed and tested on CentOS distribution.

For system installations and upgrades for the new E5-MS the RedHat Package Manager architecture, Packages, RPM installation and upgrade procedures are available.

7.3 Backup and Restore (E5-MS 45.0)

The E5-MS is configured to backup database tables, configuration files and other data on predetermined scheduled intervals.

Storage and Content

The E5-MS backup storage required is dependent on the size of the DataBase with a minimum of 100MB free disk space. The backup .csv files include directories such as html, conf, images, icons, users, LUI and CMI scripts.

Automatic or Manual Backup

The E5-MS robust framework provides the System Administrator an automatic backup daily at 2:00 am. The E5-MS grants access to the System Administrator to manually or automatically define the backup interval for the files, such as, daily, weekly or day of the month.

Once the backup process starts, all other operations should stop. Depending of the size of the EAGLE 5 database files and number of EAGLE 5 STP systems managed and/or E5-MS configured (Small, Medium, Large or Upper Bound), the process should take a minimum of five minutes during normal operations.

Status of Backup

The status of the backup is logged in Audit Trails and can be viewed by a User with User Audit permissions from the E5-MS. The Audit Trail details viewed from the User Audit screen provides the Scenario, User name, Operation name, Audit Time, Status (Success or Failure), Category and Description.

Backup to an External Location

It is recommended to store the backup at an external device (e.g., NAS drive) mounted to the server. The System Administrator will set the destination location of the external backup manually.

Restore in E5-MS

The system user can use the backup files to restore all the database tables. During the restore process, the E5-MS must be shut down to ensure the restore script deletes the database tables and re-creates them using the database backup file.

7.4 Command Management Interface (Configuration) (E5-MS 45.0)

The Command Management Interface (CMI) is an optional feature to enhance the experience of the system users while interfacing with the EAGLE 5. The user can only retrieve events in the E5-MS Core system, however using the CMI enables the user to send commands and continue to interact manually or setup automatic commands to run at a set interval on the EAGLE 5. The CMI includes:

- A fully integrated CMI permissions management to the E5-MS Administrator: access rights for CMI users according to CMI User Group.
- The possibility to Send commands and scripts to EAGLE 5 STP and collect results.
- Manage and review logs containing information about E5-MS activities, including CMI command script execution.

 **Note:**

E5-MS User(s) attempting to access an EAGLE 5 system via the CMI without the right permissions will not be granted access, an error message displays and the access will be denied.

Detailed Description

The **Send Command** is listed under **Configuration** on the left pane of the E5-MS GUI for easy access. System users now have the ability to execute commands on EAGLE 5 from E5-MS.

Conveniently located within the Send Command screen are three significant panes. These panes are displayed from top to bottom as followings:

- Select EAGLE 5 screen - enables the user to choose EAGLE 5(s) to the login or logout
- Create Command screen - enables the user to create a command to be sent to EAGLE 5
- Command Execution Results screen - displays the login, logout and other command execution results from EAGLE 5

Select EAGLE(s) pane

The Select EAGLE(s) pane provides two lists:

- Available EAGLE 5 list - provides the names of all the EAGLE 5 systems that are assigned to the logged-in user's usergroup.
- Logged-in EAGLE 5 list - provides the names of all the EAGLE 5 systems that the user has successfully logged in.

Create Command pane

The Create Command pane is a tabbed pane with two tabs available:

- Build Command tab
- Type Command tab

The Build Command tab enables a user to build a valid command to be sent to EAGLE 5 by selecting from either the Command Class or Command drop-down lists.

The Type Command table provides users that are familiar with EAGLE 5 commands a text box. The text box allows the user to type the complete command string quickly and send it to the desired EAGLE 5.

Command Execution Results pane

The Command Execution Results pane is also tabbed with the results of login, logout and other commands. Each tab is associated with the name of each EAGLE 5 a user attempted to login and execute commands.

E5-MS CMI provides log files of all user activity and all commands executed by the users.

The **Category Management** is listed under the Send Command within **Configuration** on the left pane of the E5-MS GUI for easy access. The screen will display all categories created by the user are listed. The user can create, rename, delete and view the scripts a category.

The **Script Management** is listed under Category Management within **Configuration** in the left pane of the E5-MS GUI for easy access. The screen will display a table that list the scripts created by the user and provides the following options:

- View/modify/execute/delete an existing script
- View last execution results for a script
- Create a new script

By default, all the scripts created by the user are listed on the Script Management screen. The user has the option to view scripts in a particular category.

7.5 Configurable CMI behavior against errors during script execution (Release 46.3)

This feature provides more options when using CMI Scripts, specifically in case of errors during script execution. While creating/modifying a script via the Create Script/Modify Script interfaces, a CMI user will be able to select one of the following behaviors:

- Continue - continue script execution on errors

- Stop - stop script execution on errors
- Configurable Stop On Error - define the required script execution behavior on command failures on a per-command basis

See *Interface User's Guide* for more information.

7.6 Counter for command rejection at CMI (Release 46.3)

This feature provides a summary of script execution. In order to show a summary of script execution, OCEEMS supports a number of counters related to script execution. These counters are available to users at the end of the script execution. They provide information regarding the CMI script execution, including the user who executed the script, start and stop time for the script, commands that failed or executed successfully, etc. Examples are as follows:

- Script executed by <username>
- Start time: <Date and time when script execution started>
- End time: <Date and time when script execution ended>
- Estimated No. Of Commands: <An estimated no. of commands in the script>
- Executed Commands: <number of commands that were executed>
- Successful Commands: <number of commands that were successful>
- Failed Commands: <number of commands that failed>
- Global Error: <any error of global nature that failed the script e.g., login failure on EAGLE>

This feature is supported for both Ad hoc and scheduled script execution. The execution summary is to be done on a per EAGLE node basis. For scheduled CMI scripts, these counters can be viewed by launching script execution results in the **Last Execution Result** column.

See *Interface User's Guide* for more information.

7.7 Decoupling of OCEEMS from EAGLE (Release 46.6)

The Decoupling of OCEEMS from EAGLE makes the OCEEMS independent of various EAGLE releases or versions. The OCEEMS will not be coupled with a single EAGLE release or version; it will be compatible with any particular EAGLE release 46.3 and later, but only one EAGLE release at a time. Instructions for OCEEMS users to update their EAGLE command HTML help files for future releases, see *Interface User's Guide*.

Decoupling of the Command Manager Interface (CMI) from EAGLE

This feature makes the OCEEMS independent of the EAGLE release. The user will be able to access the command set of any EAGLE release 46.3 and later, from OCEEMS, but only one EAGLE release at a time.

Decoupling of the Measurement Schema from EAGLE

From OCEEMS 46.6.0 and later, the user will be able to access the new measurement reports introduced in EAGLE 46.x.x from OCEEMS 46.x.x without upgrading OCEEMS from one version to another.

7.8 E5-MS Support of EPAP Alarms via SNMP Feed (E5-MS 46.0)

This enhancement enables the E5-MS to manage Oracle Communications EAGLE Application Processor (EPAP) alarms. Previously, alarms could be received from the EAGLE connected to the EPAP, but there was no option to directly receive and manage EPAP alarms in the E5-MS. E5-MS now supports a south bound SNMP interface to the EPAP servers for fault management. In addition, an EPAP 16.0 node might not be directly connected to EAGLE, and this feature allows for direct management of the EPAP alarms in those new configurations.

Configuration of an EPAP node in the E5-MS is through an EPAP Discovery menu. EPAP nodes are then visible in the fault management menus and maps. EPAP alarms received from the south bound SNMP interface can be forwarded on the E5-MS north bound interface.

Notes:

- E5-MS 46.0 supports EPAP 16.0.
- EPAP supports SNMPv2c.

7.9 E5-MS Support of LSMS Alarms via SNMP Feed (E5-MS 46.0)

This enhancement enables the E5-MS to manage Oracle Communications LSMS alarms. Previously, there was no option to manage LSMS alarms in the E5-MS. E5-MS now supports a south bound SNMP interface to the LSMS servers for fault management. Configuration of LSMS nodes in the E5-MS is through an LSMS Discovery menu. LSMS nodes are then visible in the fault management menus and maps. LSMS alarms received from the south bound SNMP interface can be forwarded on the E5-MS north bound interface.

Notes:

- E5-MS 46.0 supports LSMS version 12.0 and 13.0.
- LSMS supports SNMPv1.

7.10 EAGLE EMS Support and Compatibility with EAGLE 46.3 (OCEEMS 46.3)

This feature provides OCEEMS Release 46.3 with support and compatibility with EAGLE Release 46.3 and its features. The following features are introduced in EAGLE 46.3:

- AINP LNP Feature
- EAGLE MNP Data Base support for 240M DN
- EAGLE - Obsolete OAM Measurements
- Increase LNP DB Capacity (504M)

- Remove EAGLE FAK control
- Sigtran IPSPG application on SLIC Card
- SMS-MO Blocking SCCP Spoofing
- SS7 Firewall on EAGLE

See *Release Notes* for EAGLE Release 46.3 for detailed information on the features.

7.10.1 Hardware

The IPSPG on Service and Link Interface Card (SLIC) Feature introduces support for the SLIC.

7.11 EAGLE EMS to support IPv6 for SBI for EPAP (Release 46.3)

This feature enhances OCEEMS to manage IPv6 enabled EPAP nodes. As part of this feature, OCEEMS provides the following functionality:

- Discovery - An interface to discover IPv6 enabled EPAPs in network and add them to OCEEMS.
- Map - An interface to display the added IPv6 enabled EPAP in OCEEMS map view and provide options for launching SSH terminal and web interface on the EPAP.
- Fault - An interface to display IPv6 enabled EPAP's alarms in both tabular and map interfaces.
- Security - An interface to restrict users' access to IPv6 enabled EPAPs discovery, map, and fault operations.



Note:

In order to discover and manage IPv6 enabled EPAPs, the OCEEMS server must be dual stack (IPv4/IPv6) enabled.

See *Interface User's Guide* for more information.

7.12 Fault Management (E5-MS 45.0)

The Fault Management module provides the user a graphical interface to monitor multiple EAGLE 5 systems managed by the E5-MS. The real-time updates from the EAGLE 5 are displayed on a Network Events screen and provides detailed information to the E5-MS user.

E5-MS Fault Management provides/supports:

- Both TL1 and SNMP southbound interfaces.
- Storage of all alarms and events history in a DataBase (DB) for a maximum of 30 days.
- A minimum of 200 events per second (200 TPS).
- Configurable and user defined network maps and text based event lists.

View administration

The Fault Management module applies correlation and aggregation rules on events to generate alarms. This feature ensures all events generated are logically grouped to the actual state of the EAGLE 5 and its sub-components. The real-time updates provide:

- Hierarchical views (including trees) to allow fast navigation and direct access to the different layers of views.
- View a list of different events of each Users.
- Graphical view of network resources and sub-resources.
- Detailed EAGLE hardware views (chassis view) showing frames, shelves, cards and peripherals.

The System Administrator is provided a very detailed interface in order to manage individual users' rights, permissions, actions, views, managed elements and command access. Each users can have different views and filters The fields displayed in the Alarms screen accessible under Fault Management tree node are the:

- Resource
- Sub-Resource
- UAM/UIM/MRN Number
- Severity
- Message
- Protocol
- Device Timestamp
- E5-MS Timestamp
- Count
- Owner
- Acknowledgement Time

The user can customize the fields for viewing a subset of data that satisfies specific criteria in both Alarms and Network Events screens.

Filtering Alarms

- E5-MS provides functionality of Add, Remove or Modify custom views. Custom view are filtered views of Alarms and Network Events GUI based on the following criteria:
 - Event Severity
 - Event Resource and/or Sub-Resource
 - Event Alarm Id (Unsolicited Alarm Message Number or Unsolicited Informational Message number)
 - Event Text - filter on key word

Synchronization between Primary and Redundant E5-MS servers

The application allows synchronization between the Primary and Redundant E5-MS sites (if the optional mated pair architecture is chosen). This includes (but is not limited to) synchronization for:

- Fault Management users

- Alarm and Event Views

7.13 Inventory Management (E5-MS 45.0)

The Inventory Management GUI feature is a compliment to the existing E5-MS Network Topology collection. This optional feature is activated from the existing advanced framework of the E5-MS. As the E5-MS Topology collection is stored in the Inventory DataBase, the Inventory Management feature retrieves and displays on a user friendly interface a comprehensive view of the EAGLE 5.

The system user can manage EAGLE 5 inventory such as card layout, shelf occupancy and links. The Inventory Management will permit the system user to manage the EAGLE 5 inventory offline.

Additional Feature

The centralized management view allows the user to manage all deployed equipment, spare card and offline hardware from a central location, this feature is an optional addition to the Inventory Management feature. This will provide the user with a holistic view of all available hardware components.

7.14 LDAP Client on OCEEMS (Release 46.6)

The LDAP Client on OCEEMS feature implements the Lightweight Directory Access Protocol (LDAP) client interface on the OCEEMS system to allow centralized user management and authentication. The LDAP protocol allows the authenticated clients to access the LDAP database and use the information to in turn authenticate users based on the information retrieved from the LDAP servers.

Figure 7-1 Sample Call Flow for LDAP Authentication



OCEEMS supports the following modes of User Authentication:

1. OCEEMS Local Authentication: In this mode, the LDAP interface is not used and all information about the user is locally stored, including encrypted passwords.
2. LDAP authentication: In this mode, the LDAP interface is used for authentication. In case the LDAP server is unreachable, authentication will not be allowed.

See *Security Guide* for more information.

7.15 Link Utilization Interface (E5-MS 45.0)

The Link Utilization Interface (LUI) feature is an optional feature that permits the user to view configured link capacity on the EAGLE 5 system. This is an advanced planning feature enabling the user to modify the defined capacity values then compare against the configured link capacity. The LUI feature is accessible from E5-MS GUI, once it is activated and the user is assigned permissions to the interface.

The user assigned to Link Utilization operations has access to Link Data, On Demand Polling and Threshold Configuration GUIs and the polling script entries on the Schedule Management screen. The LUI performs the following actions:

1. Creation and scheduling of polling scripts for EAGLE 5 managed by E5-MS
2. Polling of EAGLE 5(s) for link data
3. Analyzing and storing the link data in E5-MS database

Polling Scripts creation and scheduling

The CMI is required to create the polling scripts. The following three commands are run on the EAGLE 5 to fetch link capacity data:

- `RTRV-SLK` - Retrieves all the links and the respective parameters. `LOC`, `LINK`, `LSN`, `SLC`, `TYPE`, `BPS`, and `SLKTPS` of configured links are available from this command output and are clearly defined in the column headers of the output.
- `REPT-STAT-CARD` - Defines type and capacity of different link types.
- `REPT-STAT-IPTPS` - Displays the `CONFIG` capacity values for `IPGWxtype` of links and `IPSG` of cards.

The polling scripts (scheduled and manual) are saved as three types of datafiles, `RTRV-SLK`, `REPT-STAT-CARD` and `REPT-STAT-IPTPS`. All datafiles are created in a directory where LUI validates, analyzes and stores the datafiles. This process will continue with all new datafiles added to the directory. All polling scripts are scheduled to run at 01:10 AM daily.

EAGLE Discovery

The Link Data GUI display the link data of all the EAGLE 5 systems managed by E5-MS. The user selects the EAGLE 5 system from a drop down menu and clicks `Get Links`. The screen provides results in a table format with the following data:

- `LOC`
- `LINK`
- `LSN`
- `TYPE`

- USER DEFINED CAPACITY
- LINK CAPACITY

On Demand Polling

The On Demand Polling GUI provides the user the ability to select one or more EAGLE 5 systems to start polling simultaneously. The results of the polling displays in the Polling Script Execution Results screen. For each EAGLE 5 the user attempted to run, a new tab is created corresponding to the EAGLE 5 system.

LUI Measurements Thresholding

The LUI Measurements Thresholding feature is an enhancement to the E5-MS Measurement module. This feature optimizes the link data to calculate the utilization of the type of link, linkset and card. The LUI Measurement Thresholding GUI will enable the user to configure Thresholds Alarm Value, Severity Level and Threshold Clear Value and to specify actions to take when the EAGLE link, linkset, or card crosses the thresholds. The alarms generated by LUI Measurements Thresholding feature are visible on the Alarms screen under Fault Management in E5-MS.

7.16 Measurement Module (E5-MS 45.0)

The E5-MS Measurement Agent parses the performance data from EAGLE 5 Measurements Platform and uses a FTP transfer as .csv files to the E5-MS database. The measurements available include:

- STP System Total Measurements
- Component Measurements
- Component Measurements
- Network Management Measurements
- Daily Availability Measurements
- Availability Measurements
- Daily Maintenance Measurements
- Hourly Maintenance Measurements
- Gateway Measurements

The following is an example of the daily EAGLE STP - SYSTOT Measurements:

- ORIGMSUS - Originated Message Signal Units (MSU) - Total number of outgoing MSUs successfully passed to Message Transfer Part (MTP) level 2 for transmission, while carrying the STP point code in the Originating Point Code (OPC).
- TRMDMSUS - Terminated MSUs - The total number of incoming MSUs carrying the STP point code in the Destination Point Code (DCP).
- THRSWMSU - Through-Switched MSUs - The total number of MSUs that did not carry the STP point code in the OPC or the DPC, and were successfully passed to the MTP level 2 for transmission.
- GTTPERFD - Global Title Translation (GTT) Performed - Usually, the total number of MSUs that successfully completed GTT. Also includes G-Port and Intelligent Network (IN) Portability (INP) MSUs that got a match in either the G-Port, INP, or GTT DB. Sometimes, GTTPERFD indicates the total number of GTTs performed on MSUs that successfully completed GTT, because several GTTs may happen for the same MSU.

- NMSCCPMH - The current daily system-wide peak SCCP message handling load in transaction per second.

The E5-MS keeps a local copy of the files for configurable intervals. All default settings are configurable by the system user. The default settings to archive and delete are as follows:

- Archive CSV files older than 2 days
- Delete archived files older than 30 days

Optional Features

The Reporting Studio and the Report Designer are two optional features designed for reporting the measurements.

To optimize the experience for the end user, the optional FTP/SFTP North Bound Interface is available to transfer the performance and measurement files to the end user application.

7.17 Network Topology Discovery (EAGLE Discovery) (E5-MS 45.0)

The E5-MS provides an EAGLE Discovery GUI interface for a system user to discover and add the EAGLE 5 to the E5-MS for management. The interface collects the layout and configuration of the EAGLE 5 in the monitored network then stores the topology of the EAGLE 5 in the E5-MS DataBase (DB) automatically. The topology data is used by other management modules such as:

- Fault Management
- Configuration (CMI)
- Performance
- Security

The topology collected via EAGLE 5 IPSM cards contains:

- EAGLE 5 name CLLI
- Number of shelves
- Card layout including card type, part-number

The inventory information discovered is used to build up a comprehensive geographical view of the EAGLE 5 from the E5-MS GUI Network Maps in the following screens:

- World view
- Continent view
- Frame level view
- Card level view

All files are backed up on the E5-MS secondary server (if one is configured).

7.18 North Bound Interfaces (E5-MS 45.0)

The North Bound Interfaces(NBI) (SNMP based) is an optional feature that provides communications of all events (alarms) from both the E5-MS and EAGLE 5 to a registered Network Management System (NMS). Alarms forwarded through the NBI as SNMP v2c traps include:

- Alarms collected from the EAGLE 5 systems
- E5-MS alarms
- Alarms generated by feature such as Measurement Thresholding tier 1.

NBI Features

There are three NBI GUI components launched from the E5-MS GUI that provides the user with the ability to configure and manage a maximum of 10 registered Network Management Systems. The three components included are the following:

- **NBI (SNMP NBI) GUI** opens to two panes used to manage configuration of various parameters required for forwarding SNMP traps to the northbound NMS.
 - **View Existing NMS(s)** pane list all previously configured Network Management Systems.
 - **NMS Configuration** pane provides provisions for NMS Add, Modify and Delete operation.
 - * NBI GUI *Add* operation requires the following data for NMS configuration:
 - * *NMS Name* should be a logical name.
 - * *Hostname* of SNMP Manager or unique IP to receive Traps.
 - * *Community* is the SNMP Community contained in Traps.
 - * *Port* is the Destination UDP port.
 - * *Heartbeat* is the number of seconds between Heartbeat traps.
 - * The Match / Filter Criteria is an optional operation with the following configuration:
 - * *Resource*: Source of alarm
 - * *Sub-resource*: Physical and logical component of source on which the alarm was actually raised
 - * *Severity*: Criticality of alarm
 - * *Acknowledge*: Alarm is acknowledged or not at E5-MS
 - * *UAM/UIM*: UAM/UIM number of alarm received from EAGLE
- **NBI Agent Configuration GUI** is used for configure NBI agent read and write community strings. The open panes provides a Read and Write text fields, which default to the following:
 - *Read Community*: public
 - *Write Community*: private

If the matching / filtering criteria are disabled, all autonomous/resync events shall be forwarded to NMS

The NBI Agent configuration GUI provides two buttons:

- *Configure*: to set the SNMP agent community strings and restart NBI agent.
- *Cancel*: to cancel the operation.
- **Manage FTP Servers GUI** is allows the user to add, modify, delete and reset the following:
 - Unique *IP address*
 - *Port*
 - *Username Password*
 - *FTP Directory*

7.19 OCEEMS Support of SNMPv3 for North Bound Interfaces (OCEEMS 46.2)

This feature provides SNMP v3 support for Oracle Communications EAGLE Element Management System (OCEEMS) North Bound Interfaces (NBIs). With this feature, OCEEMS supports both SNMP v2c and SNMP v3 northbound.

The three supported SNMP modes on the northbound interface include:

1. SNMP v2c Only Mode - OCEEMS only supports SNMP v2c on the northbound interface.
2. SNMP v3 Only Mode - OCEEMS only supports SNMP v3 on the northbound interface.
3. Both SNMP v2c and v3 Mode - OCEEMS supports both SNMP v2c and SNMP v3 on the northbound interface.



Note:

SNMP v3 Only Mode is recommended and enabled by default for new installations.

A new Varbind named "alertSourceIp" is introduced in the OCEEMS NBI MIB. It includes the source IP address of network element where the alarm/trap originated and is available in both v2c and v3 traps.

Refer to the MIB files for more information on the OCEEMS NBI MIB.

Refer to *Interface User's Guide* for SNMP v3 configuration.

7.20 OCEEMS to support SNMP v3 for EPAP (OCEEMS 46.5)

This feature provides OCEEMS Release 46.5 with support for EPAP over SNMP v3 protocol on southbound interface. This includes EPAP Inventory Operations (Add/Modify/Delete) support and Fault Management over SNMPv3 protocol, and Resynchronization Operation over SNMPv3/v2c for EPAP.

EPAP SNMPv3 user discovery is initiated by the OCEEMS user by providing valid details in the EPAP Discovery GUI. Before adding EPAP on OCEEMS, the OCEEMS user must ensure that OCEEMS is configured on the EPAP side with a valid SNMP v3 user.

See *Interface User's Guide* for SNMPv3 support information.

7.21 OCEEMS to support SNMP v3 for LSMS (OCEEMS 46.5)

This feature provides OCEEMS Release 46.5 with support for LSMS over SNMP v3 protocol on southbound interface. This includes LSMS Inventory Operations (Add/Modify/Delete) support, Fault Management over SNMPv3 protocol, and Resynchronization Operation over SNMPv3 only for LSMS.

LSMS SNMPv3 user discovery is initiated by the OCEEMS user by providing valid details in the LSMS Discovery GUI. Before adding LSMS on OCEEMS, the OCEEMS user must ensure that OCEEMS is configured on the LSMS side with a valid SNMP v3 user.

See *Interface User's Guide* for SNMPv3 support information.

7.22 Platform and Operating System Requirements (E5-MS 46.0)

E5-MS 46.0 requires a Linux 64-bit operating system, such as Oracle Enterprise Linux 6.4. E5-MS 46.0 was tested on Oracle Enterprise Linux 6.4.

The end user interface is based on a Java 7 client interface.

7.23 Remove the need of root privileges to run/maintain/operate EEMS (Release 46.3)

This feature removes the need of super user 'root' for running the OCEEMS application. This feature allows non-root users to perform start/stop/restart server operations, as well as update configuration files.

With this feature, the use of 'root' user is limited to OCEEMS installation/upgrade/uninstallation procedures only.

Once the OCEEMS installation/upgrade is completed and a non-root user for OCEEMS operations has been created using the `updatePrivilegesForUser.sh` script, the installer is required to logout of the root user session. Now only the configured non-root user is used for further initial configuration for OCEEMS (creation of the SSL certificate, installation of schema, running other required scripts, etc.) and for OCEEMS operations.

See *Interface User's Guide* for more information.

7.24 Report Designer (E5-MS 45.0)

The Report Designer is an optional feature to create, customized and manage all the reporting, security and performance related settings on the EAGLE 5 Network. This feature is a compliment to the E5-MS Reporting Studio. The reporting features include:

- Creates reports on ad hoc basis

- Creates reports using a defined template
- Provides a designer interface to create/update templates
- Exports reports in various report formats such as pdf, html, xls, jpeg, png, gif, xml, csv, rtf and txt
- Report template management
- Provides a Repository browser for managing existing report templates and view created reports
- Provides a scheduler interface to user, for scheduling report generation

Reports Remote Interface

The Reports Remote Interface provides the following:

- Ad Hoc Reporting - Allows creating reports on the fly without any predefined template.
- Configuration - Allows a user to manage all the reporting, security and performance related settings.
- Data Source Configuration - Allows configuring the data sources to be used for report generation.
- Repository Browser - Shows listing of existing reporting templates and allows management of them.
- Scheduler - Allows a user the ability of scheduling of report generation by creating named scheduled tasks.
- Report Designer is to used design, create and update report templates by the User.

Optional Features

The Link Utilization Interface Reports is optional. The feature, once the LUI feature is ON, reports information such as link, linkset and card are available.

Additional optional features of the Reporter Studio provide system users a drill down option. For instance, a linkset report can also show a link level.

7.25 Reporting Studio (E5-MS 45.0)

The Reporting Studio is an optional feature that provides the user a more comprehensive view of the measurements in the E5-MS database. The standard reports embedded in the E5-MS Reporting Studio are:

- Alarm/Event summary
 - Extracts alarm and event history with selective date, time, severity, alarm reference, resource, sub-resource and generate report
 - Statistics per EAGLE, date, time and severity
 - Top 10 alarms and top 10 resources per day, week and month
 - Adapts to the existing E5-MS reports related to alarms and events
- EAGLE STP Measurements
 - STP - Systot

- * Daily Systot reports connecting key counters (granularity of either 30 minutes or 15 minutes depending on STP settings)
 - * ORIGMSUS
 - * TRMDMSUS
 - * THRSWMSU
 - * GTTPERFD
 - * NMSCCPMH
- Link Utilization Interface Reports
 - Once the LUI feature is ON, reports such as link, linkset and card are available.
 - Additional features of the Reporting Studio provide system users a drill down option. For instance, a linkset report can also show a link level.

The user can execute automatic in formats such as:

- HTML, PDF, Text, RTF, XML, JPG
- Optional formats: emails, JAR, XLS, ZIP

7.26 Search engine in EMS CMI script execution results page (Release 46.3)

This feature provides a keyword-based search for CMI command/script execution results.

To support search engine functionality for command/script execution results, a **Search** button is provided on Send Command/Adhoc execution/Scheduled execution screens.

See *Interface User's Guide* for more information.

7.27 Security Administration (E5-MS 45.0)

The E5-MS Security Administration tool provides the System Administrator to customize an individual user access to E5-MS based on the user login access ID. The secured user access includes the:

- Password management
 - Password complexity management
 - Password expiration rules management
 - Password are stored in a secured and encrypted file (or database)

The System Administrator will configure the following to ensure all system user's IDs, roles, access to the E5-MS have an Audit Trail:

- Authorization for users and groupsviews
- Roles views
- Operations views
- Managed Object views

An activity log is generated each time a user accesses features and functions of the E5-MS. Since the customer owns the Hardware and Operating System, the *root* account and privileged account (Super Users) are owned by the customer.