

# Oracle® Communications ASAP

## Service Request Translator User's Guide



Release 7.4.1

G13670-01

March 2025

The Oracle logo, consisting of a solid red square with the word "ORACLE" in white, uppercase, sans-serif font centered within it.

ORACLE®

Copyright © 2012, 2025, Oracle and/or its affiliates.

This software and related documentation are provided under a license agreement containing restrictions on use and disclosure and are protected by intellectual property laws. Except as expressly permitted in your license agreement or allowed by law, you may not use, copy, reproduce, translate, broadcast, modify, license, transmit, distribute, exhibit, perform, publish, or display any part, in any form, or by any means. Reverse engineering, disassembly, or decompilation of this software, unless required by law for interoperability, is prohibited.

The information contained herein is subject to change without notice and is not warranted to be error-free. If you find any errors, please report them to us in writing.

If this is software, software documentation, data (as defined in the Federal Acquisition Regulation), or related documentation that is delivered to the U.S. Government or anyone licensing it on behalf of the U.S. Government, then the following notice is applicable:

U.S. GOVERNMENT END USERS: Oracle programs (including any operating system, integrated software, any programs embedded, installed, or activated on delivered hardware, and modifications of such programs) and Oracle computer documentation or other Oracle data delivered to or accessed by U.S. Government end users are "commercial computer software," "commercial computer software documentation," or "limited rights data" pursuant to the applicable Federal Acquisition Regulation and agency-specific supplemental regulations. As such, the use, reproduction, duplication, release, display, disclosure, modification, preparation of derivative works, and/or adaptation of i) Oracle programs (including any operating system, integrated software, any programs embedded, installed, or activated on delivered hardware, and modifications of such programs), ii) Oracle computer documentation and/or iii) other Oracle data, is subject to the rights and limitations specified in the license contained in the applicable contract. The terms governing the U.S. Government's use of Oracle cloud services are defined by the applicable contract for such services. No other rights are granted to the U.S. Government.

This software or hardware is developed for general use in a variety of information management applications. It is not developed or intended for use in any inherently dangerous applications, including applications that may create a risk of personal injury. If you use this software or hardware in dangerous applications, then you shall be responsible to take all appropriate fail-safe, backup, redundancy, and other measures to ensure its safe use. Oracle Corporation and its affiliates disclaim any liability for any damages caused by use of this software or hardware in dangerous applications.

Oracle®, Java, MySQL, and NetSuite are registered trademarks of Oracle and/or its affiliates. Other names may be trademarks of their respective owners.

Intel and Intel Inside are trademarks or registered trademarks of Intel Corporation. All SPARC trademarks are used under license and are trademarks or registered trademarks of SPARC International, Inc. AMD, Epyc, and the AMD logo are trademarks or registered trademarks of Advanced Micro Devices. UNIX is a registered trademark of The Open Group.

This software or hardware and documentation may provide access to or information about content, products, and services from third parties. Oracle Corporation and its affiliates are not responsible for and expressly disclaim all warranties of any kind with respect to third-party content, products, and services unless otherwise set forth in an applicable agreement between you and Oracle. Oracle Corporation and its affiliates will not be responsible for any loss, costs, or damages incurred due to your access to or use of third-party content, products, or services, except as set forth in an applicable agreement between you and Oracle.

# Contents

## Preface

---

Audience	v
Documentation Accessibility	v
Diversity and Inclusion	v

## 1 The Service Request Translator

---

Process Overview	1-2
------------------	-----

## 2 Installing the SRT

---

Installing and Managing the SRT	2-1
---------------------------------	-----

## 3 Upgrading the SRT

---

## 4 Working with SRT Components

---

Translation Process	4-1
SRT and SRP Message Queues	4-7
Logging with log4j	4-8
Configuring Event Templates	4-8
SRT Translation	4-8
Sample SrtTranslation.xsd	4-9
XSLT Conversions	4-10
Sample Transformation	4-11
Lookups	4-12
Configuring srtServiceModel.xsd	4-16
serviceBundle	4-17
serviceAction	4-18
querySpawningLogic	4-18
External Adapters	4-19
JDBCAdapter	4-19
Class Name	4-19

Parameters	4-19
Example	4-20
BSF Adapter	4-20
Class Name	4-20
Parameters	4-20

## A Sample XML Files, Schemas, and Transformations

---

Sample activationModel.xml	A-1
Sample srt.xml	A-3
Sample translation.xml	A-9
Sample translation.xslt	A-9
Sample Usage of XML and XPATH Parameters	A-11

# Preface

This guide provides an overview of Oracle Communications ASAP Service Request Translator (SRT), contains instructions for installing SRT, and describes its components.

## Audience

This document is intended for system administrators, system integrators, and other individuals who need to maintain and work with ASAP.

## Documentation Accessibility

For information about Oracle's commitment to accessibility, visit the Oracle Accessibility Program website at <http://www.oracle.com/pls/topic/lookup?ctx=acc&id=docacc>.

### Access to Oracle Support

Oracle customers that have purchased support have access to electronic support through My Oracle Support. For information, visit <http://www.oracle.com/pls/topic/lookup?ctx=acc&id=info> or visit <http://www.oracle.com/pls/topic/lookup?ctx=acc&id=trs> if you are hearing impaired.

## Diversity and Inclusion

Oracle is fully committed to diversity and inclusion. Oracle respects and values having a diverse workforce that increases thought leadership and innovation. As part of our initiative to build a more inclusive culture that positively impacts our employees, customers, and partners, we are working to remove insensitive terms from our products and documentation. We are also mindful of the necessity to maintain compatibility with our customers' existing technologies and the need to ensure continuity of service as Oracle's offerings and industry standards evolve. Because of these technical constraints, our effort to remove insensitive terms is ongoing and will take time and external cooperation.

# 1

## The Service Request Translator

The Oracle Communications ASAP Service Request Translator (SRT) enables a variety of tasks within a transformation computation, including mapping, data lookup, and message transformation. Mapping tasks allow upstream requests to be decomposed into one or more downstream requests. Data lookup functions can involve retrieving data from external systems (such as databases). Transformation actions can involve presentation formatting. The SRT is triggered by an XML source document and generates an XML target document as its output.

**Note:**

SRT is not available in Cloud Native deployment.

Figure 1-1 Service Request Translator Context

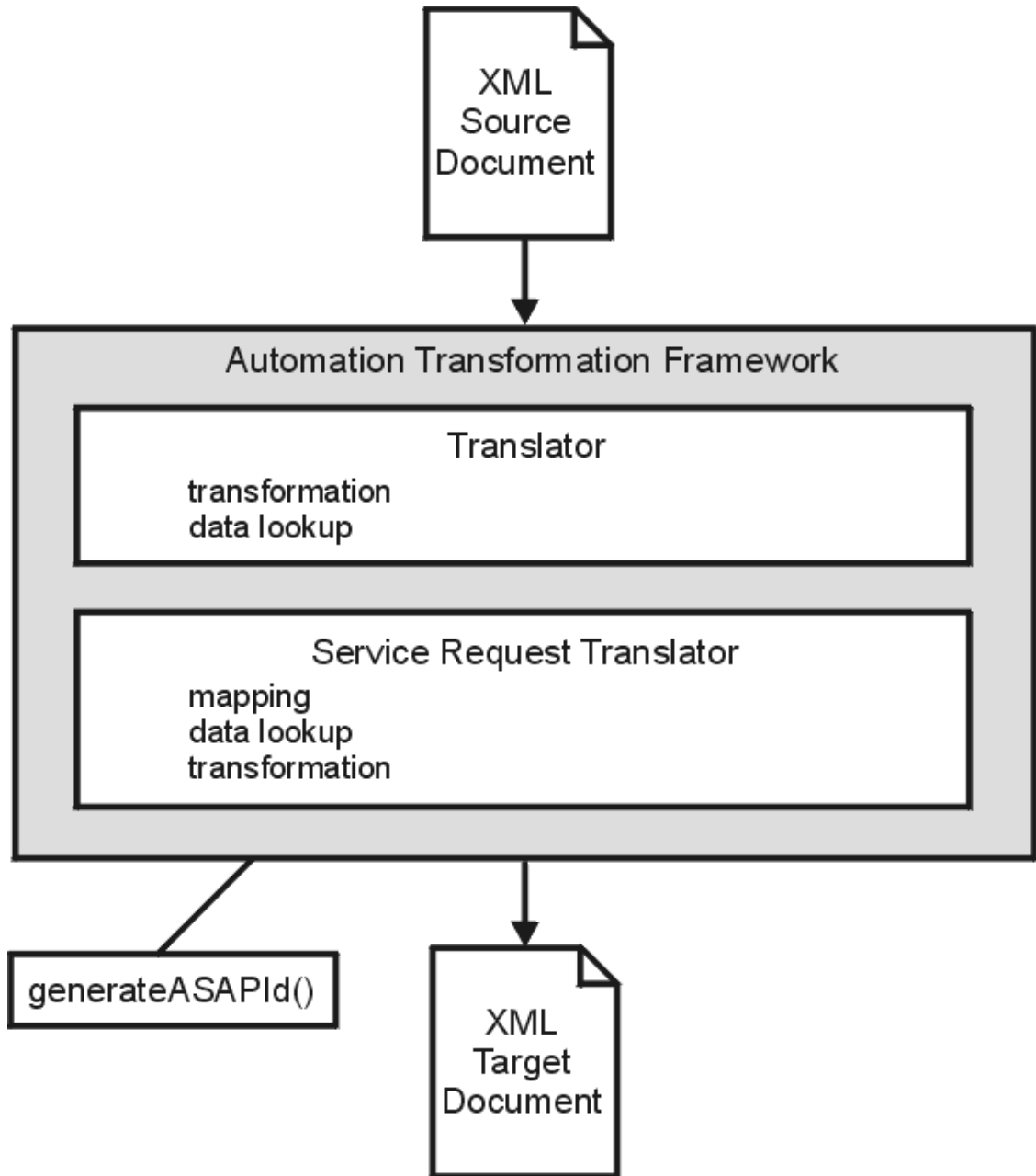

## Process Overview

Figure 1-2 illustrates an end-to-end process flow for a service activation in which the SRT provisions a service.

Figure 1-2 SRT Process Flow

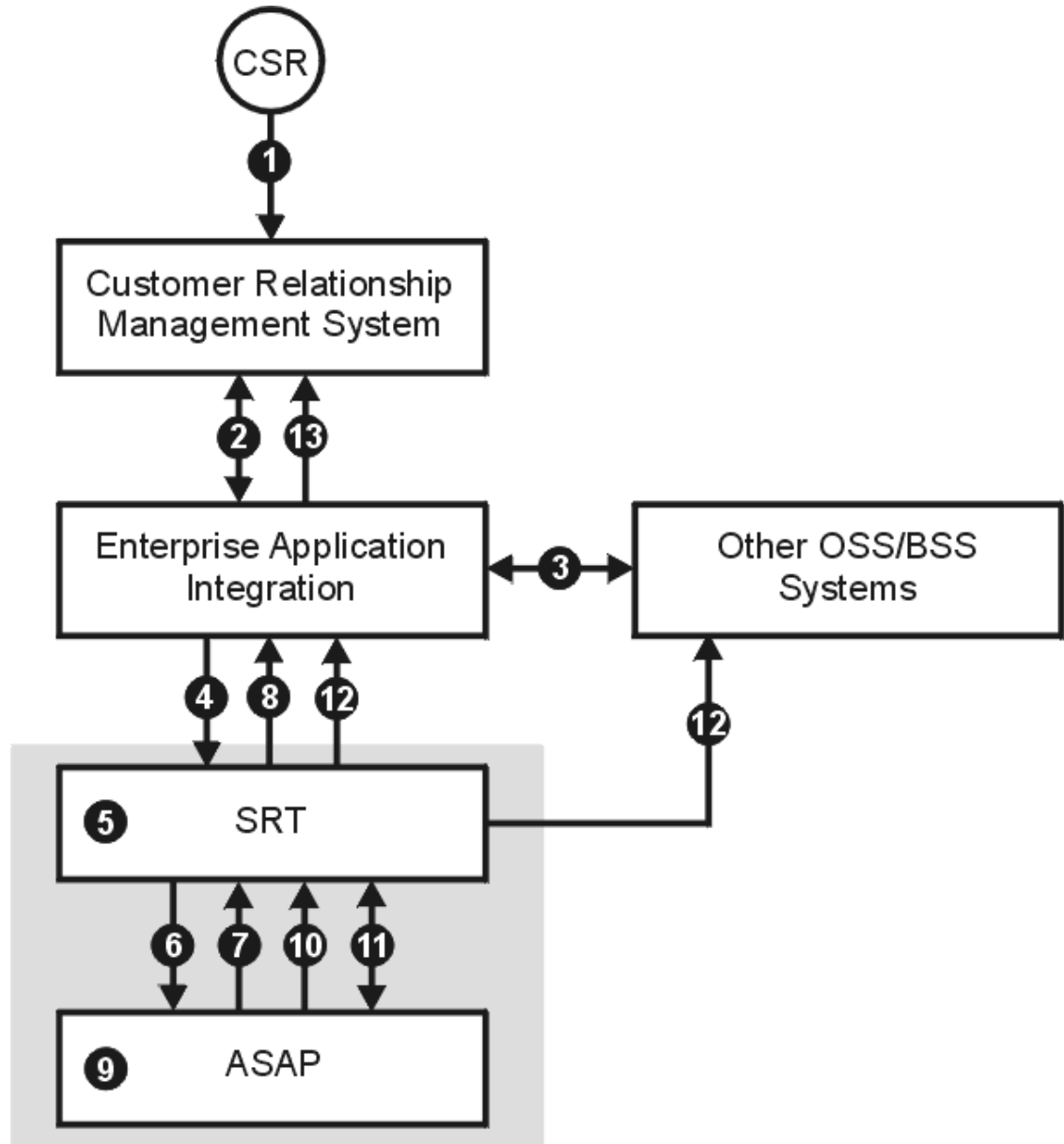

1. A customer service representative (CSR) receives a request.
2. The CSR creates a service order and enters it into the customer relationship management (CRM) system. The service order includes information about the subscriber and the selected services.
3. The CRM submits the service order to the Enterprise Application Integration (EAI).
4. Other Operations Support Systems (OSS)/ Business Support Systems (BSS) interact with the EAI to process the order and contribute additional provisioning information to the order. For example, an order may include the following information before it is submitted to ASAP:
  - MSISDN
  - IMSI (SIM details)



- GSM bearer service details
  - Supplementary services list (CFD, CWT)
  - KI (SIM details)
  - Algorithm (SIM details)
  - Carrier Code
  - Profile
  - OIC
  - Welcome message
5. The SRT receives notification from the upstream EAI bus that a message is available and an order is ready to be processed. The SRT determines that this notification represents a new service order.
  6. The message headers are saved in the database and managed by the SRT application logic. The actual Java Message Service (JMS) message (including headers and payload) is saved in the database by Oracle WebLogic Server, by configuring the JMS destination (in this case, a queue) to be saved in the database.

The system translates the new service order by performing the following actions:

- ASAP creates a new work order template to handle the service order.
- A new unique work order ID is generated by the system using either a field on the incoming request or predefined custom logic. For example, if multiple CRM systems are used, it may not be possible to find unique IDs from incoming requests because each CRM system may generate duplicate IDs. This possible duplication of IDs may make it difficult to correlate work order IDs. However, the system can be configured to generate a new unique work order ID based on the Originator work order property (to identify which CRM system submitted the request) and the Service Order ID.
- The system extracts each generic service from the incoming service order. For each generic service, the system does the following:
  - Runs optional custom logic (such as composing one or more ASAP services based on a combination of input parameters and/or tokens and places any derived ASAP services on the ASAP work order. For example:

```
"c_", action, service, technology, softwareLoad
```
  - Determines if there are statically-defined ASAP service mappings, runs any optional spawning logic for each (for example, if a network element identifier was not present on the work order, a certain CSDL may be excluded from the ASAP order), and places the appropriate ASAP services on the ASAP work order.
  - Runs optional custom logic for each statically-defined ASAP service and places any derived ASAP services on the ASAP work order.
- Using predefined mappings (including optional/required parameter configurations), the system identifies the parameters associated with each ASAP service that has been placed on the order and extracts values from the parameters received on the service order. The ASAP parameters are added to the ASAP work order. Incoming parameters are mapped to outgoing parameters.
- Using a predefined configuration, the system identifies the default values for parameters whose values are not available on the generic service order. The default values are added to the ASAP work order.
- Using a predefined configuration, the system runs any custom logic that is defined for any ASAP parameters. For example, network element ID parameters (in this case

having no incoming service order value) will have preconfigured logic defined that will be used to retrieve a set of (possibly indexed) network element IDs.

 **Note:**

If the data required to provision the service is not provided by the original service request application, the SRT can retrieve data from external systems other than the order entry or CRM system. You can use these extensions to access external data from another system such as an inventory system. For example, the extension could retrieve the NE ID of a switch and then update a CSDL parameter.

 **Note:**

If the SRT goes down after saving the message context and creating the work order in SARM, it is not necessary to send another `CreateOrderByValueRequest`. After a message has been received from upstream and the transformed `createOrderByValueRequest` has been delivered to the Java SRP's queue, that transaction is complete and does not need to be repeated in the event of SRT failure. When the SRT starts again, the next message will be an ASAP event. This event will be picked up by SRT, the appropriate plug-in launched, the context loaded from the database by using the work order ID, and then a transformation of the event to the upstream's format is run and delivered back upstream.

7. After successfully receiving the generic service order, generating the ASAP work order, and performing the service translation, the system submits the work order to ASAP and waits for a response.
8. The system receives a response from ASAP indicating that the work order has been successfully submitted.

 **Note:**

If the SRT goes down while it is processing `orderComplete` or `OrderFailEvent`, when the SRT starts back up, it will identify unprocessed messages in the topic and will launch the appropriate plug-in to handle these messages, as though the events had just been delivered.

9. The system notifies the EAI that the associated generic service order has been successfully submitted to ASAP.
10. Externally (downstream), the ASAP work order is decomposed into atomic actions.
11. The system receives notification from ASAP that the work order has either succeeded or failed.
12. The system retrieves any related information/error messages associated with the work order from ASAP.
13. The system notifies the EAI that the corresponding generic service order has either succeeded or failed and provides the corresponding information/error message.

14. The EAI notifies the CRM of the success or failure of the order.

# 2

## Installing the SRT

This chapter describes how to install and uninstall, configure and unconfigure, deploy and undeploy the Oracle Communications ASAP Service Request Translator (SRT).

The installation for the SRT consists of an ant build file in the install directory SRT/install.xml.

When you use ant (supplied with the ASAP environment) to run the installation, you can obtain help with the ant command as follows:

```
ant -projecthelp -buildfile install.xml
```

The project Help includes a description of the installation file, how to run it, and all available targets.

## Installing and Managing the SRT

Install the SRT by doing the following:

### Installing the SRT

1. Go to the Oracle software delivery website:  
<https://edelivery.oracle.com>
2. Download the `ASAP.version.build.srt.tar` file.
3. Put the `ASAP.version.build.srt.tar` file in `ASAP_Home` directory, where `ASAP_Home` is the directory in which ASAP is installed.
4. Source the `ASAP_Home/Environment_Profile`.

5. Run the following command:

```
tar xvf ASAP.version.build.srt.tar
```

This creates two tar files `srt.tar` and `srt_docs.tar`.

6. Run the following command:

```
tar xvf srt.tar
```

This creates the SRT directory.

7. Go to the SRT directory.
8. Run the following command:

```
ant -buildfile install.xml deploy
```

### Note:

If you enabled SSL when you installed ASAP, SRT will also use SSL.

This runs the default 'install' target identified in install.xml. This command customizes the SRT.ear file with the ASAP environment ID, creates all required resources, and deploys the SRT into the WebLogic Server.

Other targets are listed in [Table 2-1](#):

**Table 2-1 Ant Target**

Ant Target	Functionality
install	Configures the WebLogic Server, customizes the SRT.ear file, and deploys it to a server. Temporary files are deleted after completion. If no targets are specified, the ant command default to this value.
uninstall	Removes the SRT.ear file from the Oracle WebLogic Server, and deletes Oracle WebLogic Server resources created during installation.
configure	Creates resources on the WebLogic Server.
unconfigure	Removes resources on the WebLogic Server.
deploy	Deploys the SRT.
query	Checks WebLogic Server resources for the SRT.
undeploy	Undeploys the SRT

[Table 2-2](#) lists resources created by the 'configure' target. If a target already exists, the script will continue processing. These same resources will be deleted with the 'unconfigure' target, except for the JMSServer, which is assumed to have been created as part of an ASAP installation.

**Table 2-2 Created Resources**

Resource Name	Resource JNDI	Type	Purpose
asap.env_id.JMSServer	None.	JMSServer	Hosts all JMS queues and topics. This is normally created by an ASAP installation.
SRT.MessageQueue	System.asap_envid.ApplicationType.ServiceActivation.Application.1-0;7-4;ASAP.Comp.SRT.MessageQueue	JMSQueue	The SRT processes all messages placed in this queue.
SRT.ResponseQueue	System.asap_envid.ApplicationType.ServiceActivation.Application.1-0;7-4;ASAP.Comp.SRT.ResponseQueue	JMSQueue	If 'reply-to' is not specified for an inbound message, the response will be placed in this queue.
SRT.MessageErrorQueue	System.asap_envid.ApplicationType.ServiceActivation.Application.1-0;7-4;ASAP.Comp.SRT.MessageErrorQueue	JMSQueue	The queue that stores messages from the SRTMessageQueue that cannot be processed.
SRT.JSRPResponseQueue	System.asap_envid.ApplicationType.ServiceActivation.Application.1-0;7-4;ASAP.Comp.SRT.JSRPResponseQueue	JMSQueue	The queue that SRT uses to listens for responses from the JSRP.
SRT.EventErrorQueue	System.asap_envid.ApplicationType.ServiceActivation.Application.1-0;7-4;ASAP.Comp.SRT.EventErrorQueue	JMSQueue	The queue that stores messages from the JSRPEventTopic that cannot be processed.

# 3

## Upgrading the SRT

To upgrade an existing SRT installation with a newer version, do the following:

1. Go to the Oracle software delivery website:

<https://edelivery.oracle.com>

2. Download the patch `ASAP.R7_n_n.Bn.srt.tar` (`ASAP.R7_4_1.B280.srt.tar` represents the ASAP release and `bn` represents the build number).
3. Put the `ASAP.R7_n_n.Bn.srt.tar` (`ASAP.R7_4_1.B280.srt.tar`) file in `ASAP_Home` directory, where `ASAP_Home` is the directory in which ASAP is installed.

4. Source the `ASAP_Home/Environment_Profile`.

5. Un-tar the patch:

```
tar xvf patch
```

This creates two tar files `srt.tar` and `srt_docs.tar`.

6. Un-tar the `srt.tar` file.

```
tar xvf srt.tar
```

This creates the SRT directory.

7. Change the directory to the SRT directory:

```
cd ASAP_Home/SRT
```

8. Run the following command:

```
ant -buildfile install.xml undeploy
```

9. Run the following command:

```
ant -buildfile install.xml customize deploy clean
```

# 4

## Working with SRT Components

This chapter describes the end-to-end translation process, with particular emphasis on the components of the translation that you must configure.

### Translation Process

An example of a typical translation process follows:

1. A customer service representative (CSR) receives a request to add a new subscriber with Global System for Mobile communications (GSM) bearer service, several basic supplementary services such as call forwarding (CFD) and call waiting (CWT) and voicemail service.
2. The CSR creates a service order and enters it into the customer relationship management system (CRM). The service order includes information about the subscriber and the services they have selected.
3. The CRM submits the service order to the Enterprise Application Integration (EAI).
4. Other Operations Support Systems (OSS)/ Business Support Systems (BSS) interact with the EAI to process the order and contribute additional provisioning information to the order. For example, an order may include the following information before it is submitted to ASAP:
  - MSISDN
  - IMSI (SIM details)
  - GSM bearer service details
  - Supplementary services list (CFD, CWT)
  - KI (SIM details)
  - Algorithm (SIM details)
  - Carrier Code
  - Profile
  - OIC
  - Welcome Message
5. The EAI publishes a message (XML document) containing the following information:
  - The parameters listed above
  - Service bundle name or Service action name
  - Action (for example, ADD)
  - Provisioning parameters (label, value)
  - System ID
  - Work order properties such as due date and time, priority etc.

When an incoming message is published by the upstream system, it is received by the `SrtMessageQueue` and a service request order is created that will serve as the source of the translation.

The following is an example of an incoming message.

```
<?xml version="1.0" encoding="UTF-8"?>

<UPSTREAM_Order_Value xmlns:xsi="http://www.w3.org/2001/XMLSchema-instance">
  <OrderLevelInfo>
    <ApplicationClientId>Upstream</ApplicationClientId>
    <ServiceOrderId>ADDFEAT</ServiceOrderId>
    <ScheduleActivationDate>2005-01-13T12:00:00</ScheduleActivationDate>
    <OrderType>ChangeSubscriberService</OrderType>
    <PayMethod>Pre-Paid</PayMethod>
    <SIM>
      <!--The first 5 character of region (55555)-->
      <IMSI>5555510007</IMSI>
      <KI>0</KI>
      <Algorithm>None</Algorithm>
    </SIM>
    <Old_SIM>
      <Old_IMSI>5555510009</Old_IMSI>
      <Old_KI>0</Old_KI>
      <Old_Algorithm>String</Old_Algorithm>
    </Old_SIM>
    <OrderPriority>5</OrderPriority>
    <ParentKey/>
    <ExternalSystemId>ExternalSysId-Upstream</ExternalSystemId>
  </OrderLevelInfo>
  <Products>
    <ProductCode>CW</ProductCode>
    <ProductDescription>Add subscriber features</ProductDescription>
    <Action>NEW</Action>
    <MSISDN>6425259999</MSISDN>
    <ServiceAttributes>
      <AttributeName>3WC</AttributeName>
      <AttributeValue>1</AttributeValue>
    </ServiceAttributes>
    <ServiceAttributes>
      <AttributeName>CLI</AttributeName>
      <AttributeValue>1</AttributeValue>
    </ServiceAttributes>
    <ServiceAttributes>
      <AttributeName>CWT</AttributeName>
      <AttributeValue>0</AttributeValue>
    </ServiceAttributes>
    <Old_MSISDN>0</Old_MSISDN>
    <Profile>None</Profile>
    <NetworkID>None</NetworkID>
  </Products>
</UPSTREAM_Order_Value>
...
```

Based on a value in the service request order (`UPSTREAM_Order_Value` in the example), the `SrtTranslation.xsd` file is called to perform a translation. At this point, the translation includes the work order's header portion.

Work order headers are also mapped based on the mapping defined in the message type. For example, if the incoming order contains a priority, purchase order number, and due date, these values will be included in the translation, provided they are incorporated in the `SrtServiceModel.xsd` file as lookups or are provided by means of a translation. For more



information on work order headers, refer to the ASAP work order header and work order properties section of *ASAP System Administrator's Guide*.

The headers that are populated are independent of the service actions selected to appear on the work order.

In addition to work order headers, the SRT allows for any combination of service bundle parameters to be used to compose ASAP work order header parameters (for example, allowing for the upstream work order ID and external system ID to be used to generate a work order ID).

Oracle Professional Services or other qualified personnel are responsible for translations. Translations are defined in `SrtTranslation.xsd`. For more information, see "[SRT Translation](#)."

Parameter mappings can be achieved by means of XSLT conversions or lookups.

Lookups are performed by external instance adaptors. See "[External Adapters](#)" for more information.

After the Automation Transformation Framework produces the interim work order, the order is passed to the SRT to perform additional mappings, data lookups, and transformations. The interim work order is validated against the `SRTServiceActivation.xsd` file. For more information on this schema, refer to *SRT Online Reference* installed with the SRT software.

If the inbound work order contains a parameter that identifies a service bundle such as bundle ID, order type, or product code, as in the previous example, the SRT generates the service bundles and associated CSDLs (service actions) on the ASAP work order.

Inbound work orders can also contain service actions with parameter mappings and lookup definitions, without the need to model these as a service bundle. This allows the support of service actions directly during the translation of service orders from upstream.

The basic format of the XML that is validated against the schema appears as follows:

```
<?xml version="1.0" encoding="UTF-8"?>
<srtServiceModel xmlns="http://www.metasolv.com/ServiceActivation/2004/ ServiceBundle"
xmlns:xsi="http://www.w3.org/2001/XMLSchema-instance" xsi:schemaLocation="http://
www.metasolv.com/ServiceActivation/2004/ ServiceBundle
C:\ASAP\srt\srtServiceModel.xsd">
  <serviceBundle>
    <serviceBundleActionName>String</serviceBundleActionName>
    <serviceBundleSpawning>
      <parameterName>Text</parameterName>
      <parameterValue>Text</parameterValue>
    </serviceBundleSpawning>
    <description>String</description>
    <serviceAction>
      <serviceActionName>String</serviceActionName>
      <serviceActionSpawningLogic>
        <alwaysCondition>1</alwaysCondition>
        <expression>Text</expression>
      </serviceActionSpawningLogic>
      <serviceActionParameterMapping>
        <parameterName>String</parameterName>
        <parameterValue>String</parameterValue>
      </serviceActionParameterMapping>
      <includeOrderDataInResponse>true</includeOrderDataInResponse>
      <description>String</description>
    </serviceAction>
  </serviceBundle>
  <serviceAction>
    <serviceActionName>C_CALLFWD_BUSY_ADD_POTS-OPTIONS</serviceActionName>
```

```

<serviceActionSpawning>
  <parameterName>ServiceName</parameterName>
  <parameterValue>CallForwardBusy</parameterValue>
</serviceActionSpawning>
<description/>
  <serviceActionParameterMapping>
    <parameterName>LINE</parameterName>
    <externalParameter>
      <parameterName>LINE</parameterName>
    </externalParameter>
  </serviceActionParameterMapping>
  <serviceActionParameterMapping>
    <parameterName>NE_ID</parameterName>
    <externalParameter>
      <parameterName>NEID</parameterName>
    </externalParameter>
  </serviceActionParameterMapping>
  <serviceActionParameterMapping>
    <parameterName>NPA</parameterName>
    <externalParameter>
      <parameterName>NPA</parameterName>
    </externalParameter>
  </serviceActionParameterMapping>
  <serviceActionParameterMapping>
    <parameterName>NXX</parameterName>
    <externalParameter>
      <parameterName>NXX</parameterName>
    </externalParameter>
  </serviceActionParameterMapping>
</serviceAction>
<querySpawningLogic>
  <northBoundMapping>
    <parameterName>String</parameterName>
  </northBoundMapping>
  <returnDataOnParameter>
    <regularExpression>String</regularExpression>
    <evaluateCondition>>true</evaluateCondition>
  </returnDataOnParameter>
</querySpawningLogic>
</srtServiceModel>

```

A more detailed sample of the XML appears in "[Sample srt.xml](#)." See also "[Configuring srtServiceModel.xsd](#)."

For detailed information on the schema, refer to *SRT Online Reference*.

For each service request on the service request order, the mapping definition is queried for the ordered set of possible service actions. The SRT then evaluates the spawning logic of each service action for input parameters (contained on the service request source). All true evaluations become service actions on the work order. All false actions are not added to the order. The service request must conform to `srtServiceModel.xsd` schema.

After the SRT has determined all work order service actions, the SRT performs parameter mapping. The SRT obtains all required and optional parameters from the service request source and adds them to the work order. If a parameter has no value, but a default is defined in `srtServiceModel.xsd`, the default is used. If there is no default for a missing required parameter, this is considered a translation error.

Once the mapping has completed, an `orderValueRequest` is created and is posted to the JSRP RequestQueue.

You need to ensure that the services (CSDLs and ASDLs) contained in the work order conform to the content and structure set out in the ServiceModel.xsd schema. ServiceModel.xsd defines the content and structure of one or more ServiceModel.xml files. This file ensures that the element hierarchy and document structure of ServiceModel.xml are correct and ensures element and attribute content adheres to the defined datatype.

ServiceModel.xsd contains the elements and structure to define:

- Network actions (ASDLs) and their associated rollback conditions, parameters, and associated devices/software loads.
- Device mappings (atomicDeviceMap), which provide a type definition to map ASDLs to network element types.
- CSDLs and their associated rollback conditions, priorities, provisioning events, and mappings to ASDLs.

Figure 4-1 ServiceModel.xsd

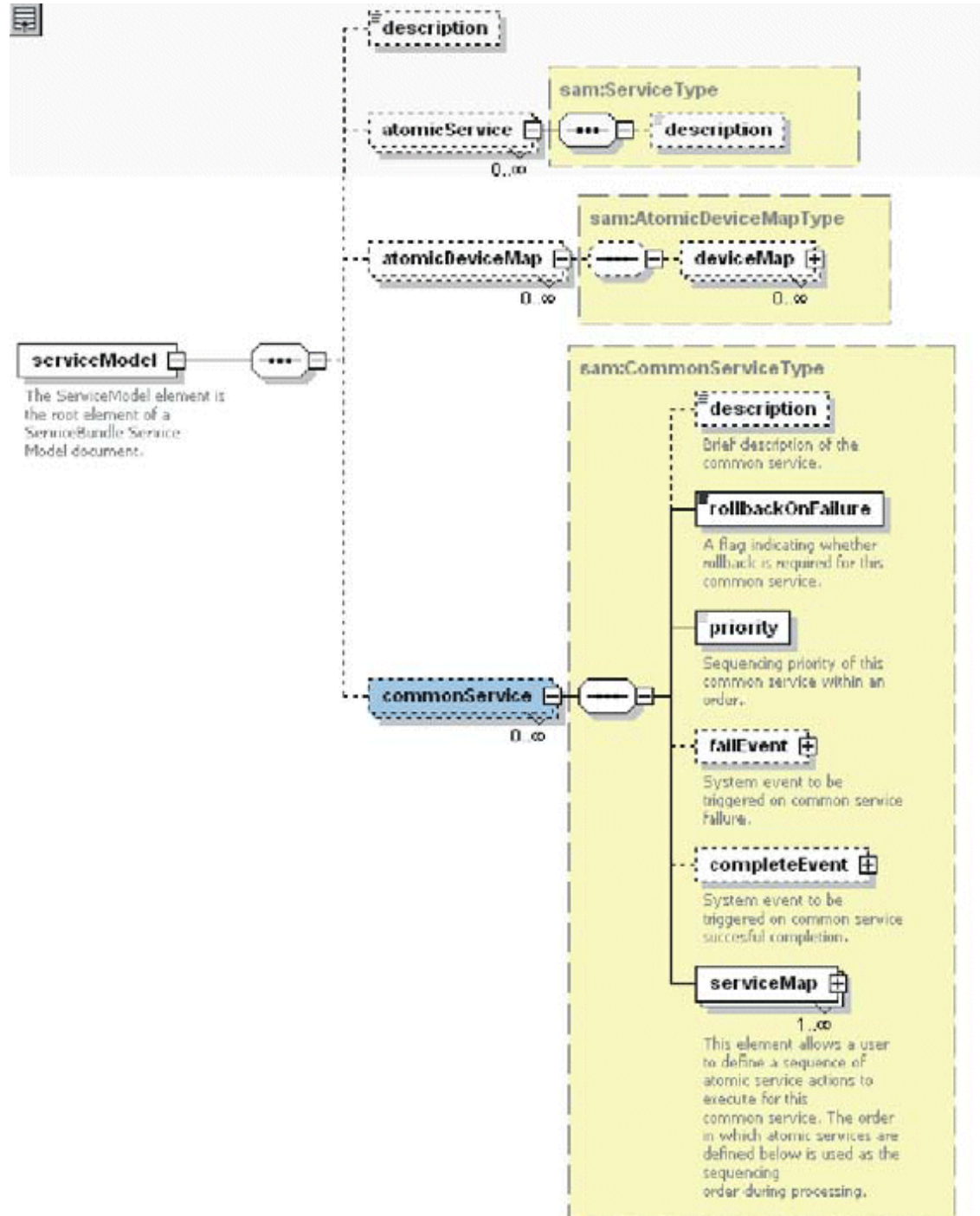

ServiceModel.xsd is fully annotated. Online documentation related to this schema is located in *ASAP Online Reference*. Detailed instructions on constructing a valid service model are contained in *ASAP System Administrator's Guide*. The `ASAP_Home\samples\sadt` directory contains sample service models.

The XML files you create that contain the service models can have any name, provided the `<ServiceModel>` element in the activation model deployment descriptor (activation-model.xml) correctly references it.

**Note:**

SRT orders the service bundles (that is, CSDLs) according to the order of service request, rather than the configuration in the SRT. If CSDL level/priority is specified for an individual CSDL, the SARM still adjusts the CSDL execution order. Therefore, in order to ensure the execution of service bundles, CSDL level should not be used when modelling CSDLs.

## SRT and SRP Message Queues

The processing of messages to and from the SRT and SRP involves the message queues illustrated in [Figure 4-2](#).

**Figure 4-2 Message Queues**

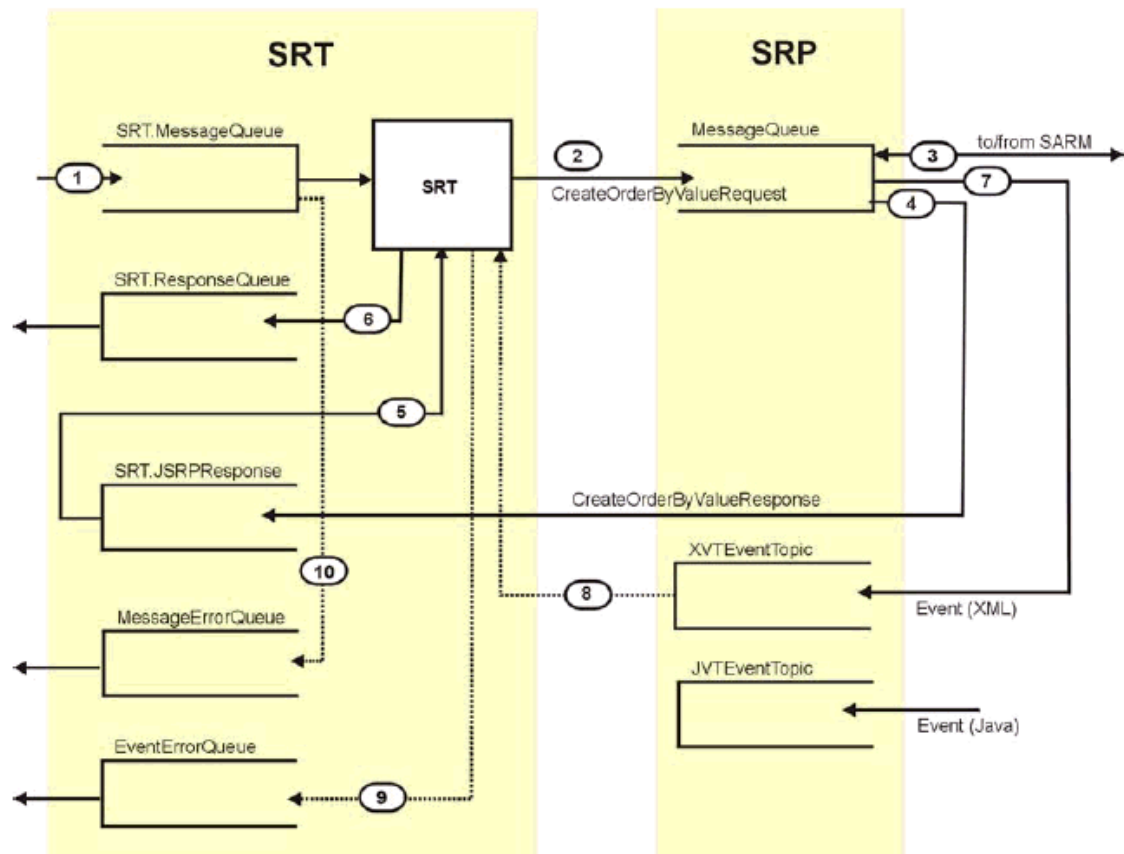

The SRT and SRP process messages as follows:

1. The upstream XML is received in the SRT.MessageQueue (1). If the message is flawed, an error message is sent to the MessageErrorQueue (10).
2. SRT creates a CreateOrderByValueRequest, which is sent to the SRP (2).
3. The SRP sends the request to the SARM (3), which acknowledges the request.

4. The SRP sends a CreateOrderByValueResponse to the SRT.JSRPResponse queue (4).
5. The response is processed by the SRT (5) and is passed to the SRT.ResponseQueue (6).
6. All I/O events from the SARM that are sent to the SRP's XVTEventTopic (7). These events include soft error events, rollback events, timeout events, failure events, and complete events, among others.
7. These events are sent to the SRT (8). Event errors are sent to the EventErrorQueue (9).

## Logging with log4j

Message logging in ASAP and the SRT is performed through log4j. For details on how to manage logging settings, refer to *ASAP System Administrator's Guide*.

## Configuring Event Templates

Extended information such as work order properties, information parameters, global work order parameters, and CSDL return parameters can be returned on an ASAP event. The details returned are controlled by template entries.

For more information refer to the descriptions of the **tbl\_event\_dataset**, **tbl\_event\_template**, and **srt\_header\_mapping** tables in *ASAP Developer's Guide*.

Templates and parameters that are defined in the **tbl\_event\_dataset** and **tbl\_event\_template** tables are referenced as XPath's in the **srt\_header\_mapping** table. The SRT iterates through the table entries and runs the configured XPath's. The returned name/value pairs are added to the JMS header properties.

To configure the event templates to be applied to events and actions from the SRT, specify XPath's as in the examples below.

### Examples

To return a specific information parameter on all event types, create a record with values similar to the following:

Name: 'IMSI'

Value: /\*[name()='mslv-sa:completeEvent']//extendedWoProperties/extendedWoProperty[name='IMSI']/value

To return all extendedWoProperties on a completed event, create a record with values similar to the following:

Name: /\*[name()='mslv-sa:completeEvent']//extendedWoProperties//name

Value: /\*[name()='mslv-sa:completeEvent']//extendedWoProperties//value

## SRT Translation

SrtTranslation.xsd enables Oracle Professional Services personnel or other users to specify the mapping logic between the parameters contained in upstream XML files and those required for srtServiceModel.xsd. The parameters included in SrtTranslation.xsd must match those referenced in the XML service activation schema.

Figure 4-3 SRT Translation

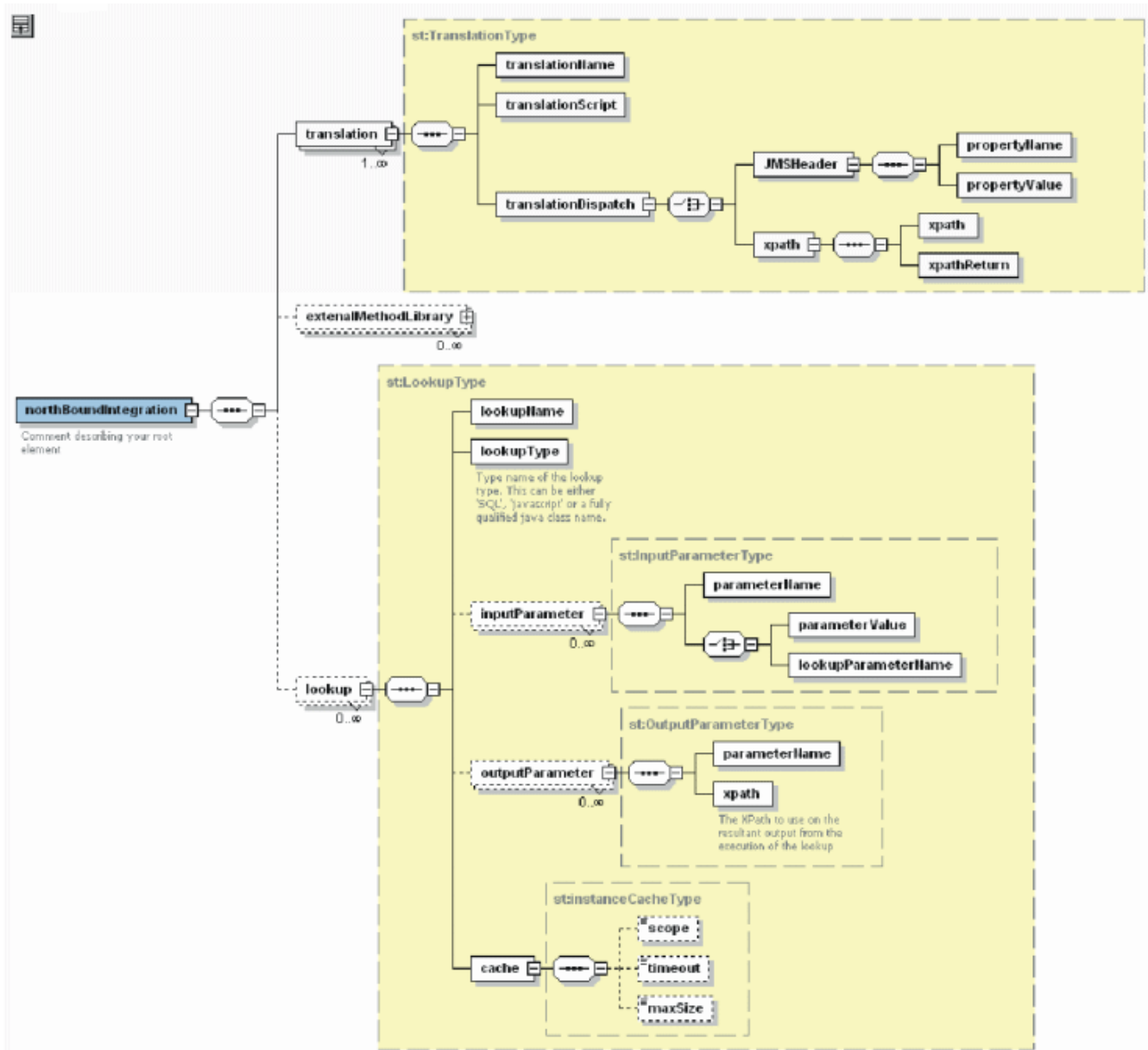

## Sample SrtTranslation.xsd

The translation takes the form of an XSLT transformation (identified in `<translationScript>translation.xslt</translationScript>` below). This translation produces an interim XML that is then passed to the SRT. This interim XML contains work order header information. The SRT initializes an ASAP work order and populates the ASAP work order header information using the SRT work order header and, in some cases, the SRT work order parameters that are pertinent to the provisioning process. In the previous example, work order header parameters are represented in the `<OrderLevelInfo>` element. As well, the `<translationScript>` element references the XSLT conversion, and the `<lookup>` elements identify the external adaptors. For more information, see "[External Adaptors](#)."

```

<?xml version="1.0" encoding="UTF-8"?>
<northBoundIntegration xmlns="http://www.metasolv.com/ServiceActivation/2004/
Translation" xmlns:xsi="http://www.w3.org/2001/XMLSchema-instance"
xsi:schemaLocation="http://www.metasolv.com/ServiceActivation/2004/Translation
C:\ASAP\srt\SrtTranslation.xsd">
  <translation>
    <translationName>Text</translationName>
    <translationScript>translation.xslt</translationScript>
    <translationDispatch>
      <xpath>
        <xpath>//cm:ApplicationClientID</xpath>1
        <xpathReturn>Upstream</xpathReturn>
      </xpath>
    </JMSHeader>
  </translationDispatch>
</translation>
<externalMethodLibrary>
  <fileName>Text</fileName>
  <libraryName>Text</libraryName>
  <type enabled="true" id="String">
    <sql>Text</sql>
  </type>
</externalMethodLibrary>
<lookup>
  <lookupName>Text</lookupName>
  <lookupType>Text</lookupType>
  <inputParameter>
    <parameterName>Text</parameterName>
    <parameterValue>Text</parameterValue>
  </inputParameter>
  <outputParameter>
    <parameterName>Text</parameterName>
    <xpath>Text</xpath>
  </outputParameter>
  <cache id="String">
    <scope>NODE</scope>
    <timeout>60000</timeout>
    <maxSize>100</maxSize>
  </cache>
</lookup>
</northBoundIntegration>

```

## XSLT Conversions

XSLT conversions enable XML transformations by means of an XSLT stylesheet. The XSLT stylesheet takes the input XML document and converts it into an output XML document.

The XSLT conversion produces a document that conforms to the SRTServiceActivation.xsd schema.

The XSLT stylesheet identifies the following:

- translationName – A unique name given to the translation script as an identifier.
- translationScript – The XSLT file that implements the translation. This file must be included in the SAR file under SRT/Translations.

<sup>1</sup> Ensure that the XPath contains a namespace prefix for use with the incoming schema (represented here by cm:).



- `translationDispatch` – The condition under which this translation is applied to the XML upstream document. It can either be based on a `JMSHeader` or be based on an `XPath` in the upstream document.

## Sample Transformation

```
<xsl:stylesheet version="1.0" xmlns:xsl="http://www.w3.org/1999/XSL/Transform"
xmlns="http://java.sun.com/products/oss/xml/ServiceActivation" xmlns:sa="http://
java.sun.com/products/oss/xml/ServiceActivation" xmlns:xsi="http://www.w3.org/2001/
XMLSchema-instance" xmlns:mslv-sa="http://www.metasolv.com/oss/ServiceActivation/2003"
xmlns:co="http://java.sun.com/products/oss/xml/Common" xmlns:fo="http://www.w3.org/
1999/XSL/Format">
  <xsl:output method="xml" indent="yes" standalone="yes" media-type="xml"/>
  <xsl:template match="UPSTREAM_Order_Value">2
    <createOrderByKeyRequest3 xmlns="http://java.sun.com/products/oss/xml/
ServiceActivation" xmlns:xsi="http://www.w3.org/2001/XMLSchema-instance" xmlns:mslv-
sa="http://www.metasolv.com/oss/ServiceActivation/2003" xmlns:co="http://java.sun.com/
products/oss/xml/Common">
      <orderValue xsi:type="mslv-sa:ASAPOrderValue">
        <apiClientId>SRT</apiClientId>
        <orderKey>
          <co:applicationContext>
            <co:factoryClass/>
            <co:url/>
            <co:systemProperties/>
          </co:applicationContext>
          <co:applicationDN>System/ENV_ID/ApplicationType/ServiceActivation/
Application/1-0;4-7;ASAP/Comp/</co:applicationDN>
          <co:type>javax.oss.order.CreateOrderValue</co:type>
          <primaryKey>
            <xsl:value-of select="//@serviceOrderId"/>4
          </primaryKey>
        </orderKey>
        <priority>3</priority>
        <requestedCompletionDate>2003-06-11T12:00:00</requestedCompletionDate>5
        <services>
          <parameter>
            <name>NE_ID</name>6
            <value>TOR_REM2</value>
          </parameter>
          <parameter>
            <name>DN</name>7
            <value>
              <xsl:value-of select="//number"/>
            </value>
          </parameter>
          <parameter>
            <name>LDATE</name>
            <value>236</value>
          </parameter>
          <parameter>
            <name>LCC</name>

```

<sup>2</sup> Referenced in the `<translationDispatch>` element in `SrtTranslation.xsd`.

<sup>3</sup> The action identified by the interim work order to be processed by the JSRP.

<sup>4</sup> Extracts the `serviceOrderId` from the incoming work order to serve as the primary key for the ASAP work order.

<sup>5</sup> If `<requestedCompletionDate>` is set, you do not need to send `<startOrderByKeyRequest>`; ASAP will start the order automatically when `<requestedCompletionDate>` is due. If `<requestedCompletionDate>` is *not* set, you have to send `<startOrderByKeyRequest>` to start the order.

<sup>6</sup> The default `NE_ID` provided to the ASAP work order by this transformation for this service.

<sup>7</sup> The value for `DN`, required by the ASAP work order, is extracted from the incoming work order's number parameter.

```

        <value>1</value>
    </parameter>
    <parameter>
        <name>LTG</name>
        <value>1</value>
    </parameter>
    <parameter>
        <name>LEN</name>
        <value>
            <mslv-sa:value>
                <xsl:value-of select="//len"/>
            </mslv-sa:value>
        </value>
    </parameter>
</services>

```

...

The complete sample XSLT is located on "[Sample translation.xslt](#)."

## Lookups

If the incoming XML does not contain the required parameters, you can include lookups in `SrtTranslation.xsd`. For example, if the incoming work order does not include the parameter `NE_ID`, a lookup can determine the `NE_ID` based on another value on the work order, such as the `IMSI`.

- `lookupName` – A unique lookup name.
- `lookupType` – The lookup type. Can be SQL or Javascript or any other fully qualified Java class name.
- `inputParameter` – Defines the name a parameter will be given when passed to the lookup and its value. These parameters can either be statically defined or dynamically derived from other lookups or the upstream order.
- `outputParameter` – The parameter that is the result of the lookup and the XPath to use on the output of the lookup.
- `cache` – Identifies the scope, timeout, and maximum size (in MB) of the lookup results.

Three levels of cache are supported and set using the `scope` child element

- `NONE`: External instances are not cached.
- `NODE`: (default) Lookup results are cached at the order level. This means the same lookup will be performed only once regardless of how many times it is called in the order. This setting is useful if it is moderately expensive to retrieve the external instance and the field referencing the external instance is a multi-instance node. Cached instances are only reused across multi-instance nodes if the actual resolved values of all parameters are identical and the lookup adapter class is the same.
- `SYSTEM`: External instances are cached and reused system wide. This is useful if retrieving the external instance is expensive and it is performed frequently. Cached instances results are only reused if the actual resolved values of all parameters are identical and the lookup adapter class is the same.

If `<scope>` is set to `SYSTEM`, two additional elements are supported. `<timeout>` is the number of milliseconds for which a cached external instance is valid. `<maxSize>` is the maximum number of actual entries in the cache that will be maintained at any one time for this defined external instance. The default value for `<timeout>` is 15000 (15 seconds). The default value for `<maxSize>` is 50.

The SRT supports the splitting and concatenation of upstream parameters. Each lookup input parameter has an attribute `sourceDocument`, which indicates to the SRT which XML document source to use when resolving the input parameter value. If multiple lookups are chained together, the SRT ensures they are executed in correct sequence. The `sourceDocument` attribute defaults to `ASAP_SRT_ORDER`.

The `<lookupParameterName>` element indicates where to perform the lookup. This element can contain the value `ASAP_SRT_ORDER` or a lookup instance name.

The `InputParameterType` as defined in `SrtTranslation.xsd` appears as follows:

```
<xs:complexType name="InputParameterType">
  <xs:sequence>
    <xs:element name="parameterName">
      <xs:annotation>
        <xs:documentation>The name used to pass this parameter to the lookup
implementation</xs:documentation>
      </xs:annotation>
    </xs:element>
    <xs:choice>
      <xs:element name="parameterValue">
        <xs:annotation>
          <xs:documentation>A static value for the parameter.</
xs:documentation>
        </xs:annotation>
      </xs:element>
      <xs:element name="lookupParameterName">
        <xs:annotation>
          <xs:documentation>The name of a output parameter from either
another lookup or the order.</xs:documentation>
        </xs:annotation>
        <xs:attribute name="sourceDocument" type="xs:string"/>
      </xs:element>
    </xs:choice>
  </xs:sequence>
</xs:complexType>
```

The following is an example of `SrtTranslation.xsd` with multiple lookups chained together.

`HOST_CLLI_LOOKUP` is an SQL type lookup that takes one input parameter, `NPANXX_CLLI`, for its select SQL statement.

`NPANXX_CLLI` is the lookup result from `NPANXX_CLLI_LOOKUP`, which will concatenate the two input parameters `NPANXX` and `CLLI`.

`NPANXX` is the result from `NPANXX_LOOKUP`, and the `CLLI` is coming from order data parameter `NE_ID`.

`NPANXX_LOOKUP` takes the `NPA` and `NXX` from `NPA_LOOKUP` and `NXX_LOOKUP` and concatenates them as one single value. The `NPA` is the lookup result from `NPA_LOOKUP` and `NXX` is the lookup result from `NXX_LOOKUP`. Both of these are substrings from the order data parameter `PHONE`. At the end of lookup execution, the value will be populated back the order data parameter name `HOST_CLLI`.

```
<northBoundIntegration xmlns:xsi="http://www.w3.org/2001/XMLSchema-instance"
xmlns="http://www.metasolv.com/ServiceActivation/2004/Translation"
xsi:noNamespaceSchemaLocation="C:\parameterMap.xsd">
  <translation>
    <translationName>POTSTranslation</translationName>
    <translationScript>POTSTranslation.xslt</translationScript>
    <translationDispatch>
      <xpath>
```

```

        <xpath>//@name</xpath>
        <xpathReturn>POTS-Sample</xpathReturn>
    </xpath>
</translationDispatch>
</translation>
<lookup>
<lookupName>NPA_LOOKUP</lookupName>
<lookupType>XPATH</lookupType>
<inputParameter>
    <parameterName>xpath:function</parameterName>
    <parameterValue>substring-before</parameterValue>
</inputParameter>
<inputParameter>
    <parameterName>in:1</parameterName>
    <lookupParameterName sourceDocument="ASAP_SRT_ORDER">TELEPHONE</
lookupParameterName>
</inputParameter>
<inputParameter>
    <parameterName>in:2</parameterName>
    <parameterValue>3</parameterValue>
</inputParameter>
<outputParameter>
    <parameterName>NPA</parameterName>
    <xpath>/result/text()</xpath>
</outputParameter>
<cache id="NPA_LOOKUP_cache">
    <scope>NODE</scope>
    <timeout></timeout>
    <maxSize></maxSize>
</cache>
</lookup>
<lookup>
<lookupName>NXX_LOOKUP</lookupName>
<lookupType>XPATH</lookupType>
<inputParameter>
    <parameterName>xpath:function</parameterName>
    <parameterValue>substring</parameterValue>
</inputParameter>
<inputParameter>
    <parameterName>in:1</parameterName>
    <lookupParameterName sourceDocument="ASAP_SRT_ORDER">TELEPHONE</
lookupParameterName>
</inputParameter>
<inputParameter>
    <parameterName>in:2</parameterName>
    <parameterValue>3</parameterValue>
</inputParameter>
<inputParameter>
    <parameterName>in:3</parameterName>
    <parameterValue>3</parameterValue>
</inputParameter>
<outputParameter>
    <parameterName>NXX</parameterName>
    <xpath>/result/text()</xpath>
</outputParameter>
<cache id="NXX_LOOKUP_cache">
    <scope>NODE</scope>
    <timeout></timeout>
    <maxSize></maxSize>
</cache>
</lookup>
</lookup>

```

```

<lookupName>NPANXX_LOOKUP</lookupName>
<lookupType>XPATH</lookupType>
<inputParameter>
  <parameterName>xpath:function</parameterName>
  <parameterValue>concat</parameterValue>
</inputParameter>
<inputParameter>
  <parameterName>in:1</parameterName>
  <lookupParameterName sourceDocument="NPA_LOOKUP">NPA</lookupParameterName>
</inputParameter>
<inputParameter>
  <parameterName>in:2</parameterName>
  <lookupParameterName source-document="NXX_LOOKUP">NXX</lookupParameterName>
</inputParameter>
<outputParameter>
  <parameterName>NPANXX</parameterName>
  <xpath>/result/text ()</xpath>
</outputParameter>
<cache id="NPANXX_LOOKUP_cache">
  <scope>NODE</scope>
  <timeout></timeout>
  <maxSize></maxSize>
</cache>
</lookup>
<lookup>
<lookupName>NPANXX_CLLI_LOOKUP</lookupName>
<lookupType>XPATH</lookupType>
<inputParameter>
  <parameterName>xpath:function</parameterName>
  <parameterValue>concat</parameterValue>
</inputParameter>
<inputParameter>
  <parameterName>in:1</parameterName>
  <lookupParameterName sourceDocument="NPANXX_LOOKUP">NPANXX</lookupParameterName>
</inputParameter>
<inputParameter>
  <parameterName>in:2</parameterName>
  <lookupParameterName sourceDocument="ASAP_SRT_ORDER">NE_ID</lookupParameterName>
</inputParameter>
<outputParameter>
  <parameterName>NPANXX_CLLI</parameterName>
  <xpath>/result/text ()</xpath>
</outputParameter>
<cache id="NPA_LOOKUP_cache">
  <scope>NODE</scope>
  <timeout></timeout>
  <maxSize></maxSize>
</cache>
</lookup>
<lookup>
<lookupName>HOST_CLLI_LOOKUP</lookupName>
<lookupType>SQL</lookupType>
<inputParameter>
  <parameterName>jdbc:sqlStatement</parameterName>
  <parameterValue>SELECT HOST_CLLI FROM tbl_clli_route WHERE NPANXX_CLLI = ?</
parameterValue>
</inputParameter>
<inputParameter>
  <parameterName>jdbc:dataSource</parameterName>
<parameterValue>System.en08.ApplicationType.ServiceActivation.Application.1-0;5-0;ASAP.Co
mp.SARMDDataSource</parameterValue>

```

```
</inputParameter>
<inputParameter>
  <parameterName>in:1</parameterName>
  <lookupParameterName sourceDocument="NPANXX_CLLI_LOOKUP">NPANXX_CLLI</
lookupParameterName>
</inputParameter>
<outputParameter>
  <parameterName>HOST_CLLI</parameterName>
  <xpath>/sql/row-set/row/col</xpath>
</outputParameter>
<cache id="HOST_CLLI_LOOKUP_cache">
  <scope>NODE</scope>
  <timeout></timeout>
  <maxSize></maxSize>
</cache>
</lookup>
</northBoundIntegration>
```

## Configuring srtServiceModel.xsd

The srtServiceModel.xsd schema identifies the service bundles, service actions (CSDLs), and spawning logic.

Figure 4-4 srtServiceModel.xsd Schema

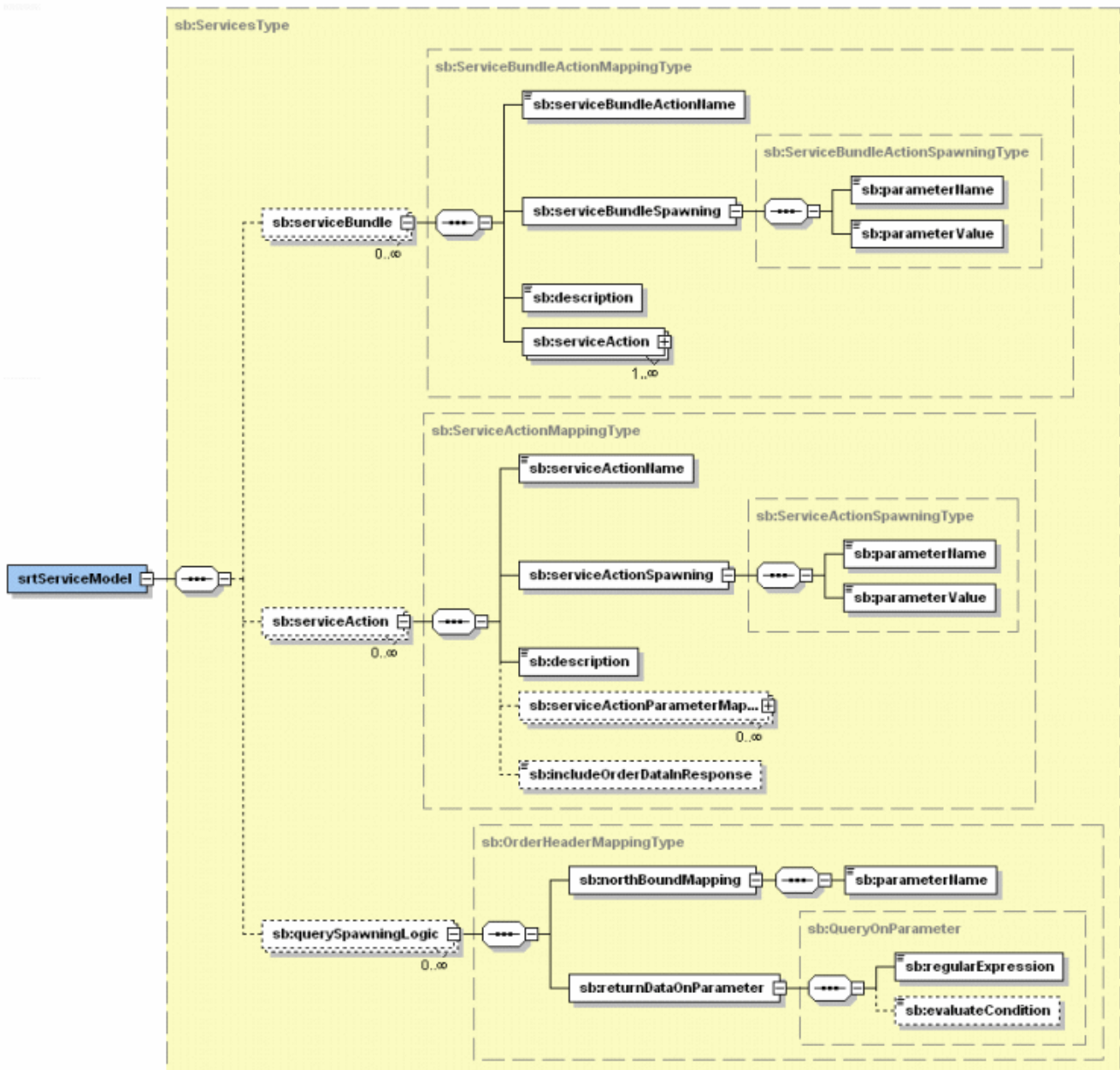

## serviceBundle

The <serviceBundle> element is described as follows:

- `serviceBundleName` – The name of the service bundle.
- `serviceBundleSpawning` – Identifies the condition under which this service bundle will be added to the work order. The condition is identified by the following:
  - `parameterName`
  - `parameterValue`
- `description` – A description of the service bundle.

- serviceAction – One or more service actions (CSDLs) that are included in the service bundle.
  - serviceName – The name of the service action (CSDL).
  - serviceActionSpawningLogic – For each CSDL associated with a service bundle, the SRT verifies whether the CSDL should be spawned.

When the SRT receives a service bundle and its associated service actions, the SRT refers to the following conditional logic:

- \* Always generate the service action – The SRT always generates the service action for this service action.
  - \* Generate service action if parameter defined – The SRT generates a particular service action only if the stated parameter is defined.
  - \* Generate service action if parameter not defined – The SRT generates a particular service action only if the stated parameter is not defined.
  - \* Generate service action if parameter defined and equal – The SRT generates a particular service action only if the stated parameter is defined and has a particular parameter value.
- serviceActionParameterMapping – Maps the parameter name on the interim order to the parameter name on the service action.
  - includeOrderDataInResponse – If TRUE, order data is included in SRT responses.

## serviceAction

The <serviceAction> element is used to support service actions (CSDLs) directly during the translation of service orders from upstream.

- serviceName – The name of the service action.
- serviceActionSpawning – Identifies the condition under which this service action will be added to the work order. The condition is identified by the following:
  - parameterName
  - parameterValue
- description – A description of the service action.
- serviceActionParameterMapping – Maps the parameter name on the interim order to the parameter name on the service action.
- includeOrderDataInResponse – If TRUE, order data is included in SRT responses.

## querySpawningLogic

The <querySpawningLogic> element is described as follows:

- northBoundMapping – Enables the querying of completed orders for additional work order information.
  - parameterName – A parameter on the work order that identifies whether work order data is returned to an upstream system on completion.
- returnDataOnParameter – Enables the querying of completed orders for additional work order information provided the evaluate condition is met.
  - regularExpression – The condition that must be met in order for the data on the work order to be returned to an upstream system.



- `evaluateCondition` – The regularExpression must evaluate to this condition for the data on the work order to be returned to an upstream system.

A sample service model appears as follows:

```
<?xml version="1.0" encoding="UTF-8"?>
<srtServiceModel xmlns="http://www.metasolv.com/ServiceActivation/2004/ServiceBundle"
xmlns:xsi="http://www.w3.org/2001/XMLSchema-instance" xsi:schemaLocation="http://
www.metasolv.com/ServiceActivation/2004/ServiceBundle
C:\ASAP\srt\srtServiceModel.xsd">
  <serviceBundle>
    <serviceBundleActionName>String</serviceBundleActionName>
    <serviceBundleSpawning>
      <parameterName>Text</parameterName>
      <parameterValue>Text</parameterValue>
    </serviceBundleSpawning>
    <description>String</description>
    <serviceAction>
      <serviceActionName>String</serviceActionName>
      <serviceActionSpawningLogic>
        <alwaysCondition>1</alwaysCondition>
        <expression>Text</expression>
      </serviceActionSpawningLogic>
      <serviceActionParameterMapping>
        <parameterName>String</parameterName>
        <parameterValue>String</parameterValue>
      </serviceActionParameterMapping>
      <includeOrderDataInResponse>true</includeOrderDataInResponse>
      <description>String</description>
    </serviceAction>
  </serviceBundle>
  <querySpawningLogic>
    <northBoundMapping>
      <parameterName>String</parameterName>
    </northBoundMapping>
    <returnDataOnParameter>
      <regularExpression>String</regularExpression>
      <evaluateCondition>true</evaluateCondition>
    </returnDataOnParameter>
  </querySpawningLogic>
</srtServiceModel>
```

## External Adapters

This section provides details on the external adapters provided with SRT.

### JDBCAdapter

This adapter lets you integrate an external system with SRT to perform lookups against the database. This adapter runs SQL and uses the results in a translation.

#### Class Name

```
com.mslv.view.rule.adapter.JDBCAdapter
```

#### Parameters

```
jdbc:sqlStatement
```

- The SQL statement to execute. Parameter placeholders can be indicated using a question mark (?). For example: `SELECT NE_ID FROM NE_LOOKUP WHERE REGION = '?'`. Each parameter can be passed with the name `in:x`, where `x` is the position of the parameter, starting from 1.

```
jdbc:dataSource
```

- The JNDI name of the JDBC datasource in Oracle WebLogic Server.

```
in:x
```

- The `x`th input parameter. Parameter numbering starts at 1.

## Example

```
<LookupType>
  <lookupName>NE_ID Lookup</lookupName>
  <lookupType>SQL</lookupType>
  <inputParameter>
    <parameterName>jdbc:sqlStatement</parameterName>
    <parameterValue>SELECT NE_ID FROM NE_ID_LOOKUP WHERE REGION = ? AND NE_TYPE = ?</parameterValue>
  </inputParameter>
  <inputParameter>
    <parameterName>jdbc:dataSource</parameterName>
    <parameterValue>com/sample/jdbc/CustomDataJDBC</parameterValue>
  </inputParameter>
  <inputParameter>
    <parameterName>in:1</parameterName>
    <lookupParameterName>REGION</lookupParameterName>
  </inputParameter>
  <inputParameter>
    <parameterName>in:2</parameterName>
    <lookupParameterName>HLR</lookupParameterName>
  </inputParameter>
  <outputParameter>
    <parameterName>NE_ID</parameterName>
    <xpath>NE_ID_LOOKUP/sql/row-set/row/NE_ID</xpath>
  </outputParameter>
</LookupType>
```

## BSF Adapter

This adapter lets you integrate the SRT with JavaScript to perform lookups, calculations, or validations against information that is located in the service request. This adapter runs an SRT server extension and uses the results as an external instance.

## Class Name

```
com.mslv.view.rule.adapter.BSFAdapter
```

## Parameters

```
bsf:scriptEngine
```

- The name of script engine.

```
bsf:script
```

- The file name of the script.

`bsf:expression`

- The expression for the script (optional).

`bsf:line`

- The line number of the script to start (optional).

`bsf:column`

- The column number of the script to start (optional).

`bsf:typeEnabled`

- The boolean value for BSF enable types.

`bsf:nodeName`

- The node name to return.

`bsf_return`

- The Boolean value to enable a return.

`in:x`

- The xth input parameter. Parameters are for the JavaScript function and parameter numbering starts at 1.

All other parameters are parameters for the JavaScript function.

# A

## Sample XML Files, Schemas, and Transformations

This appendix contains the following:

- [Sample activationModel.xml](#)
- [Sample srt.xml](#)
- [Sample translation.xml](#)
- [Sample translation.xslt](#)

### Sample activationModel.xml

```
<?xml version="1.0" encoding="UTF-8"?>
<!-- edited with XML Spy v4.2 U (http://www.xmlspy.com) by Leung, Sandra
(Nortel) -->
<activationModel xmlns="http://www.metasolv.com/ServiceActivation/2003/
ActivationModel" xmlns:xsi="http://www.w3.org/2001/XMLSchema-instance"
xsi:schemaLocation="http://www.metasolv.com/ServiceActivation/2003/
ActivationModel
D:\ccm_databases\ASAP~sleung_windows\ASAP\jmx\xsd\SA_Archive.xsd"
name="Nortel_DMS_POTS">
  <name>Nortel DMS POTS DemoInstall</name>
  <description>Nortel DMS POTS DemoInstall</description>
  <vendor>Nortel</vendor>
  <technology>DMS</technology>
  <softwareLoad>BCS36</softwareLoad>
  <version>
    <author>Nortel Networks</author>
    <label>1.2</label>
    <majorVersion>1</majorVersion>
    <minorVersion>2</minorVersion>
    <createDate>2001-11-28</createDate>
    <validDuration>P1Y2M3DT10H30M</validDuration>
  </version>
  <component>
    <serviceModel>Nortel/DMS/POTS/service_model/
add_pots_line_n_option.xml</serviceModel>
  </component>
  <component>
    <serviceModel>Nortel/DMS/POTS/service_model/
del_pots_line.xml</serviceModel>
  </component>
  <component>
    <serviceModel>Nortel/DMS/POTS/service_model/del_option.xml</
serviceModel>
  </component>
</component>
```

```
        <serviceModel>Nortel/DMS/POTS/service_model/raw_command.xml</
serviceModel>
        </component>
        <component>
                <serviceModel>Nortel/DMS/POTS/service_model/add_trk_grp.xml</
serviceModel>
        </component>
        <component>
                <serviceModel>Nortel/DMS/POTS/service_model/
del_m5209_centrex_set.xml</serviceModel>
        </component>
        <component>
                <serviceModel>Nortel/DMS/POTS/service_model/
add_m5209_centrex_set.xml</serviceModel>
        </component>
        <component>
                <serviceModel>Nortel/DMS/POTS/service_model/
dms_cfd_option_off.xml</serviceModel>
        </component>
        <component>
                <serviceModel>Nortel/DMS/POTS/service_model/
dms_cfd_option_on.xml</serviceModel>
        </component>
        <component>
                <serviceModel>Nortel/DMS/POTS/service_model/
dms_ar_option_off.xml</serviceModel>
        </component>
        <component>
                <serviceModel>Nortel/DMS/POTS/service_model/
dms_ar_option_on.xml</serviceModel>
        </component>
        <component>
                <serviceModel>Nortel/DMS/POTS/service_model/
dms_cpu_option_off.xml</serviceModel>
        </component>
        <component>
                <serviceModel>Nortel/DMS/POTS/service_model/
dms_cpu_option_on.xml</serviceModel>
        </component>
        <component>
                <serviceModel>Nortel/DMS/POTS/service_model/
dms_mdn_option_off.xml</serviceModel>
        </component>
        <component>
                <serviceModel>Nortel/DMS/POTS/service_model/
dms_mdn_option_on.xml</serviceModel>
        </component>
        <component>
                <serviceModel>Nortel/DMS/POTS/service_model/reserved_map.xml</
serviceModel>
        </component>
        <component>
                <javaProvisioningFile>
                        <jarFile>Nortel/DMS/POTS/java/lib/pots.jar</jarFile>
                </javaProvisioningFile>
        </component>
```

```

        <javaProvisioningFile>
            <jarFile>Nortel/DMS/POTS/java/lib/pots.jar</jarFile>
        </javaProvisioningFile>
    </component>
    <role name="administrator">
        <description>System Administrator</description>
    </role>
</activationModel>

```

## Sample srt.xml

```

<?xml version="1.0" encoding="UTF-8"?>
<srtServiceModel xmlns:xsi="http://www.w3.org/2001/XMLSchema-instance"
xsi:noNamespaceSchemaLocation="C:\Documents and Settings\btang\Desktop\parameterMap.xsd">
    <serviceBundle>
        <serviceBundleActionName>POTS_BUNDLE_ADD_LINE</serviceBundleActionName>
        <serviceBundleSpawning>
            <parameterName>BUNDLE_ID</parameterName>
            <parameterValue>POTS-1</parameterValue>
        </serviceBundleSpawning>
        <description>This Bundle Contains both POTS-1 and POTS-2</description>
        <serviceAction>
            <serviceActionName>C-ADD_POTS_LINE</serviceActionName>
            <includeOrderDataInResponse>true</includeOrderDataInResponse>
            <description>This is a basic Add Residential Line</description>
            <serviceActionSpawningLogic>
                <equalsCondition>
                    <parameterLabel>NE_ID</parameterLabel>
                    <parameterValue>TOR_REM1</parameterValue>
                </equalsCondition>
            </serviceActionSpawningLogic>
            <serviceActionParameterMapping>
                <parameterName>NE_ID</parameterName>
                <externalParameter>
                    <parameterName>NE_ID</parameterName>
                </externalParameter>
            </serviceActionParameterMapping>
            <serviceActionParameterMapping>
                <parameterName>DN</parameterName>
                <externalParameter>
                    <parameterName>DN</parameterName>
                    <defaultValue>6792727</defaultValue>
                </externalParameter>
            </serviceActionParameterMapping>
            <serviceActionParameterMapping>
                <parameterName>LATA</parameterName>
                <externalParameter>
                    <parameterName>LATA</parameterName>
                    <defaultValue>236</defaultValue>
                </externalParameter>
            </serviceActionParameterMapping>
            <serviceActionParameterMapping>
                <parameterName>LCC</parameterName>
                <externalParameter>
                    <parameterName>LTG</parameterName>
                    <defaultValue>1</defaultValue>
                </externalParameter>
            </serviceActionParameterMapping>
            <serviceActionParameterMapping>
                <parameterName>LTG</parameterName>
            </serviceActionParameterMapping>
        </serviceAction>
    </serviceBundle>

```

```
<externalParameter>
  <parameterName>LTG</parameterName>
  <defaultValue>1</defaultValue>
</externalParameter>
</serviceActionParameterMapping>
<serviceActionParameterMapping>
  <parameterName>LEN</parameterName>
  <externalParameter>
    <parameterName>LEN</parameterName>
    <defaultValue>1010101</defaultValue>
  </externalParameter>
</serviceActionParameterMapping>
</serviceAction>
<serviceAction>
  <serviceName>C-ADD_POTS_LINE</serviceName>
  <includeOrderDataInResponse>true</includeOrderDataInResponse>
  <description>Add Line and Options Example</description>
  <serviceActionSpawningLogic>
    <alwaysCondition/>
    <expression>NE_ID LIKE "TOR_REM2"</expression>
  </serviceActionSpawningLogic>
  <serviceActionParameterMapping>
    <parameterName>NE_ID</parameterName>
    <externalParameter>
      <parameterName>NE_ID</parameterName>
    </externalParameter>
  </serviceActionParameterMapping>
  <serviceActionParameterMapping>
    <parameterName>DN</parameterName>
    <externalParameter>
      <parameterName>DN</parameterName>
      <defaultValue>6792727</defaultValue>
    </externalParameter>
  </serviceActionParameterMapping>
  <serviceActionParameterMapping>
    <parameterName>LATA</parameterName>
    <externalParameter>
      <parameterName>LATA</parameterName>
      <defaultValue>236</defaultValue>
    </externalParameter>
  </serviceActionParameterMapping>
  <serviceActionParameterMapping>
    <parameterName>LCC</parameterName>
    <externalParameter>
      <parameterName>LTG</parameterName>
      <defaultValue>1</defaultValue>
    </externalParameter>
  </serviceActionParameterMapping>
  <serviceActionParameterMapping>
    <parameterName>LTG</parameterName>
    <externalParameter>
      <parameterName>LTG</parameterName>
      <defaultValue>1</defaultValue>
    </externalParameter>
  </serviceActionParameterMapping>
  <serviceActionParameterMapping>
    <parameterName>LEN</parameterName>
    <externalParameter>
      <parameterName>LEN</parameterName>
      <defaultValue>1010101</defaultValue>
    </externalParameter>
  </serviceActionParameterMapping>
</serviceAction>
```

```
<serviceActionParameterMapping>
  <parameterName>OPT1</parameterName>
  <externalParameter>
    <parameterName>option1</parameterName>
    <defaultValue>CTR</defaultValue>
  </externalParameter>
</serviceActionParameterMapping>
<serviceActionParameterMapping>
  <parameterName>OPT2</parameterName>
  <externalParameter>
    <parameterName>option2</parameterName>
    <defaultValue>LCDR</defaultValue>
  </externalParameter>
</serviceActionParameterMapping>
</serviceAction>
</serviceBundle>
<serviceBundle>
  <serviceBundleActionName>POTS_BUNDLE_ADD_LINE_FAILED</serviceBundleActionName>
  <serviceBundleSpawning>
    <parameterName>BUNDLE_ID</parameterName>
    <parameterValue>POTS-3</parameterValue>
  </serviceBundleSpawning>
  <description>POTS-3 Fail and Rollback Example</description>
  <serviceAction>
    <serviceActionName>C-ADD_POTS_LINE</serviceActionName>
    <includeOrderDataInResponse>true</includeOrderDataInResponse>
    <description>This Action will be failed and Rollback</description>
    <serviceActionSpawningLogic>
      <definedCondition>
        <parameterName>NE_ID</parameterName>
      </definedCondition>
    </serviceActionSpawningLogic>
    <serviceActionParameterMapping>
      <parameterName>NE_ID</parameterName>
      <externalParameter>
        <parameterName>NE_ID</parameterName>
      </externalParameter>
    </serviceActionParameterMapping>
    <serviceActionParameterMapping>
      <parameterName>DN</parameterName>
      <externalParameter>
        <parameterName>DN</parameterName>
        <defaultValue>6792727</defaultValue>
      </externalParameter>
    </serviceActionParameterMapping>
    <serviceActionParameterMapping>
      <parameterName>LATA</parameterName>
      <externalParameter>
        <parameterName>LATA</parameterName>
        <defaultValue>236</defaultValue>
      </externalParameter>
    </serviceActionParameterMapping>
    <serviceActionParameterMapping>
      <parameterName>LCC</parameterName>
      <externalParameter>
        <parameterName>LTG</parameterName>
        <defaultValue>1</defaultValue>
      </externalParameter>
    </serviceActionParameterMapping>
    <serviceActionParameterMapping>
      <parameterName>LTG</parameterName>
      <externalParameter>
```



```
        <parameterName>LTG</parameterName>
        <defaultValue>1</defaultValue>
    </externalParameter>
</serviceActionParameterMapping>
<serviceActionParameterMapping>
    <parameterName>LEN</parameterName>
    <externalParameter>
        <parameterName>LEN</parameterName>
        <defaultValue>1010101</defaultValue>
    </externalParameter>
</serviceActionParameterMapping>
<serviceActionParameterMapping>
    <parameterName>OPT1</parameterName>
    <externalParameter>
        <parameterName>option2</parameterName>
        <defaultValue>CTR</defaultValue>
    </externalParameter>
</serviceActionParameterMapping>
<serviceActionParameterMapping>
    <parameterName>OPT2</parameterName>
    <externalParameter>
        <parameterName>option2</parameterName>
        <defaultValue>3WC</defaultValue>
    </externalParameter>
</serviceActionParameterMapping>
</serviceAction>
</serviceBundle>
<serviceBundle>
    <serviceBundleActionName>POTS_4_FAIL_AND_RETRY_EXAMPLE</serviceBundleActionName>
    <serviceBundleSpawning>
        <parameterName>BUNDLE_ID</parameterName>
        <parameterValue>POTS-4</parameterValue>
    </serviceBundleSpawning>
    <description>POTS-4 Fail and Retry Example</description>
    <serviceAction>
        <serviceActionName>C-ADD_POTS_LINE</serviceActionName>
        <includeOrderDataInResponse>true</includeOrderDataInResponse>
        <description>This Action will be failed and Retry</description>
        <serviceActionSpawningLogic>
            <alwaysCondition/>
            <expression>DN = 6794747</expression>
        </serviceActionSpawningLogic>
        <serviceActionParameterMapping>
            <parameterName>NE_ID</parameterName>
            <externalParameter>
                <parameterName>NE_ID</parameterName>
            </externalParameter>
        </serviceActionParameterMapping>
        <serviceActionParameterMapping>
            <parameterName>DN</parameterName>
            <externalParameter>
                <parameterName>DN</parameterName>
                <defaultValue>6792727</defaultValue>
            </externalParameter>
        </serviceActionParameterMapping>
        <serviceActionParameterMapping>
            <parameterName>LATA</parameterName>
            <externalParameter>
                <parameterName>LATA</parameterName>
                <defaultValue>236</defaultValue>
            </externalParameter>
        </serviceActionParameterMapping>
    </serviceAction>
</serviceBundle>
</serviceBundle>
```

```

    <serviceActionParameterMapping>
      <parameterName>LCC</parameterName>
      <externalParameter>
        <parameterName>LTG</parameterName>
        <defaultValue>1</defaultValue>
      </externalParameter>
    </serviceActionParameterMapping>
    <serviceActionParameterMapping>
      <parameterName>LTG</parameterName>
      <externalParameter>
        <parameterName>LTG</parameterName>
        <defaultValue>1</defaultValue>
      </externalParameter>
    </serviceActionParameterMapping>
    <serviceActionParameterMapping>
      <parameterName>LEN</parameterName>
      <externalParameter>
        <parameterName>LEN</parameterName>
        <defaultValue>1010101</defaultValue>
      </externalParameter>
    </serviceActionParameterMapping>
    <serviceActionParameterMapping>
      <parameterName>OPT1</parameterName>
      <externalParameter>
        <parameterName>option1</parameterName>
        <defaultValue>CTR</defaultValue>
      </externalParameter>
    </serviceActionParameterMapping>
    <serviceActionParameterMapping>
      <parameterName>OPT2</parameterName>
      <externalParameter>
        <parameterName>option2</parameterName>
        <defaultValue>RETRY</defaultValue>
      </externalParameter>
    </serviceActionParameterMapping>
  </serviceAction>
</serviceBundle>
<serviceBundle>

<serviceBundleActionName>POTS_5_EXIT_MAINTENACE_MODE_FORCE_DISCONNECT</
serviceBundleActionName>
  <serviceBundleSpawning>
    <parameterName>BUNDLE_ID</parameterName>
    <parameterValue>POTS-5</parameterValue>
  </serviceBundleSpawning>
  <description>Exit Maintenace Mode - Force Disconnect</description>
  <serviceAction>
    <serviceActionName>C-ADD_POTS_LINE</serviceActionName>
    <includeOrderDataInResponse>true</includeOrderDataInResponse>
    <description>Exit Maintenace Mode - Force Disconnect</description>
    <serviceActionSpawningLogic>
      <equalsCondition>
        <parameterLabel>NE_ID</parameterLabel>
        <parameterValue>BEIJING</parameterValue>
      </equalsCondition>
    </serviceActionSpawningLogic>
    <serviceActionParameterMapping>
      <parameterName>NE_ID</parameterName>
      <externalParameter>
        <parameterName>NE_ID</parameterName>
      </externalParameter>
    </serviceActionParameterMapping>

```

```

    <serviceActionParameterMapping>
      <parameterName>DN</parameterName>
      <externalParameter>
        <parameterName>DN</parameterName>
        <defaultValue>6792727</defaultValue>
      </externalParameter>
    </serviceActionParameterMapping>
    <serviceActionParameterMapping>
      <parameterName>LATA</parameterName>
      <externalParameter>
        <parameterName>LATA</parameterName>
        <defaultValue>236</defaultValue>
      </externalParameter>
    </serviceActionParameterMapping>
    <serviceActionParameterMapping>
      <parameterName>LCC</parameterName>
      <externalParameter>
        <parameterName>LTG</parameterName>
        <defaultValue>1</defaultValue>
      </externalParameter>
    </serviceActionParameterMapping>
    <serviceActionParameterMapping>
      <parameterName>LTG</parameterName>
      <externalParameter>
        <parameterName>LTG</parameterName>
        <defaultValue>1</defaultValue>
      </externalParameter>
    </serviceActionParameterMapping>
    <serviceActionParameterMapping>
      <parameterName>LEN</parameterName>
      <externalParameter>
        <parameterName>LEN</parameterName>
        <defaultValue>1010101</defaultValue>
      </externalParameter>
    </serviceActionParameterMapping>
    <serviceActionParameterMapping>
      <parameterName>OPT1</parameterName>
      <externalParameter>
        <parameterName>OPT1</parameterName>
        <defaultValue>CTR</defaultValue>
      </externalParameter>
    </serviceActionParameterMapping>
    <serviceActionParameterMapping>
      <parameterName>OPT2</parameterName>
      <externalParameter>
        <parameterName>OPT2</parameterName>
        <defaultValue>MAINT</defaultValue>
      </externalParameter>
    </serviceActionParameterMapping>
  </serviceAction>
</serviceBundle>

<serviceBundle>
  <serviceBundleActionName>RAW-1_SEND_A_RAW_COMMAND</serviceBundleActionName>
  <serviceBundleSpawning>
    <parameterName>BUNDLE_ID</parameterName>
    <parameterValue>RAW-1</parameterValue>
  </serviceBundleSpawning>
  <description>Sends a Raw Command to the SERVORD DMS Prompt</description>
  <serviceAction>
    <serviceActionName>C-RAW_COMMAND</serviceActionName>
    <includeOrderDataInResponse>true</includeOrderDataInResponse>
  </serviceAction>
</serviceBundle>

```

```

        <description>Query all Unassigned DNSs in a Particular DN Range</description>
        <serviceActionSpawningLogic>
            <notDefinedCondition>
                <parameterName>OPT1</parameterName>
            </notDefinedCondition>
        </serviceActionSpawningLogic>
        <serviceActionParameterMapping>
            <parameterName>NE_ID</parameterName>
            <externalParameter>
                <parameterName>NE_ID</parameterName>
            </externalParameter>
        </serviceActionParameterMapping>
        <serviceActionParameterMapping>
            <parameterName>RAW_CMD</parameterName>
            <externalParameter>
                <parameterName>RAW_CMD</parameterName>
                <defaultValue>QDNSU R 5551000 5552000 ANCT S</defaultValue>
            </externalParameter>
        </serviceActionParameterMapping>
    </serviceAction>
</serviceBundle>

</srtServiceModel>

```

## Sample translation.xml

```

<?xml version="1.0" encoding="UTF-8"?>
<northBoundIntegration xmlns:xsi="http://www.w3.org/2001/XMLSchema-instance"
xsi:noNamespaceSchemaLocation="C:\parameterMap.xsd">
    <translation>
        <translationName>POTSTranslation</translationName>
        <translationScript>POTSTranslation.xslt</translationScript>
        <translationDispatch>
            <xpath>
                <xpath>//@name</xpath>
                <xpathReturn>POTS-Sample</xpathReturn>
            </xpath>
        </translationDispatch>
    </translation>
    <instance name="NCName"/>
</northBoundIntegration>

```

## Sample translation.xslt

```

<xsl:stylesheet version="1.0" xmlns:xsl="http://www.w3.org/1999/XSL/Transform"
xmlns="http://java.sun.com/products/oss/xml/ServiceActivation" xmlns:sa="http://
java.sun.com/products/oss/xml/ServiceActivation" xmlns:xsi="http://www.w3.org/2001/
/XMLSchema-instance" xmlns:molv-sa="http://www.metasolv.com/oss/ServiceActivation/2003"
xmlns:co="http://java.sun.com/products/oss/xml/Common" xmlns:fo="http://www.w3.org/
1999/XSL/Format">
    <xsl:output method="xml" indent="yes" standalone="yes" media-type="xml"/>
    <xsl:template match="/">
        <createOrderByValueRequest xmlns="http://java.sun.com/products/oss/xml/
ServiceActivation" xmlns:xsi="http://www.w3.org/2001/XMLSchema-instance" xmlns:molv-
sa="http://www.metasolv.com/oss/ServiceActivation/2003" xmlns:co="http://java.sun.com/
products/oss/xml/Common">
            <orderValue xsi:type="molv-sa:ASAPOrderValue">
                <apiClientId>SRT</apiClientId>
                <orderKey>
                    <co:applicationContext>

```

```

        <co:factoryClass/>
        <co:url/>
        <co:systemProperties/>
    </co:applicationContext>
    <co:applicationDN>System/ENV_ID/ApplicationType/ServiceActivation/
Application/1-0;4-6;ASAP/Comp/</co:applicationDN>
    <co:type>javax.oss.order.CreateOrderValue</co:type>
    <primaryKey>
        <xsl:value-of select="//@serviceOrderId"/>
    </primaryKey>
</orderKey>
<priority>3</priority>
<requestedCompletionDate>2003-06-11T12:00:00</requestedCompletionDate>
<services>
    <parameter>
        <name>NE_ID</name>
        <value>TOR_REM2</value>
    </parameter>
    <parameter>
        <name>DN</name>
        <value>
            <xsl:value-of select="//number"/>
        </value>
    </parameter>
    <parameter>
        <name>LDATA</name>
        <value>236</value>
    </parameter>
    <parameter>
        <name>LCC</name>
        <value>1</value>
    </parameter>
    <parameter>
        <name>LTG</name>
        <value>1</value>
    </parameter>
    <parameter>
        <name>LEN</name>
        <value>
            <mslv-sa:value>
                <xsl:value-of select="//len"/>
            </mslv-sa:value>
        </value>
    </parameter>
</services>
<mslv-sa:parentKey>
    <co:applicationContext>
        <co:factoryClass/>
        <co:url/>
        <co:systemProperties/>
    </co:applicationContext>
    <co:applicationDN/>
    <co:type/>
    <primaryKey/>
</mslv-sa:parentKey>
<mslv-sa:origin>MetaSolv</mslv-sa:origin>
<mslv-sa:organizationUnit>POTS</mslv-sa:organizationUnit>
<mslv-sa:batchGroup/>
<mslv-sa:rollbackState>rollback_not_required</mslv-sa:rollbackState>
<mslv-sa:externalSystemId>MetaSolv-Pots</mslv-sa:externalSystemId>
<mslv-sa:processType>IMMEDIATE</mslv-sa:processType>
<mslv-sa:neId/>

```

```

        <mslv-sa:srqAction>REMOVE</mslv-sa:srqAction>
        <mslv-sa:infoParms/>
        <mslv-sa:extendedWoProperties/>
    </orderValue>
</createOrderByValueRequest>
</xsl:template>
</xsl:stylesheet>

```

## Sample Usage of XML and XPATH Parameters

The <xmlValue> and <xpathValue> tags in SRTServiceActivation.xsd support XML and XPATH parameters. There are three ways of passing parameters to a cartridge:

1. When parameters are passed in input work order. For example, suppose you want to pass the following work order.

```

<MetaSolv>
  <MetaSolvRequest name="POTS">
    <NE_ID_UNICO-HIN>E_UNICO-HIN_1-0_HOST</NE_ID_UNICO-HIN>
    <TIME>2008-10-13T08:45:00</TIME>
    <BUNDLEID>PRODUCT_VALUE</BUNDLEID>
    <MSISDN>1234567890</MSISDN>
    <NUMBER>6742727</NUMBER>
    <LEN>1010202</LEN>
  </MetaSolvRequest>
  <XMLparm>
    <X>123</X>
  </XMLparm>
  <XPATHparm>//XYZ</XPATHparm>
  <NEWINDEX>//welcome</NEWINDEX>
  <SCALARINDEX>14</SCALARINDEX>
  <INPARM>HOST_CLLI</INPARM>
  <RETURN_DATA_PREFIX>
    <x>dummywww</x>
  </RETURN_DATA_PREFIX>
</MetaSolv>

```

You want to send XMLparm, RETURN\_DATA\_PREFIX, and XPATHparm parameters as XML and XPATH parameters respectively. For this, the cartridge developer has to create an XSLT that can extract the value of the XML parameter as an XML. Following is an example of XSLT fragment containing XPATH expression for extracting XML parameter:

```

<xmlValue><xsl:copy-of select="/MetaSolv/MetaSolvRequest/XMLparm/self::node()"></xsl:copy-of></xmlValue>

```

Following is an example of XSLT fragment containing XPATH expression for extracting XPATH parameter:

```

<xpathValue><xsl:value-of select="//XPATHparm"/></xpathValue>

```

2. When the value of XML and XPATH parameter is not available in the work order, and some default value is defined in the cartridge, then the value defined in the cartridge will be used while processing the work order.
3. The value of a parameter can also be fetched from lookup. If a lookup returns the XML as a result, then you need to be careful while using the XPATHs on the lookup. Currently, the XPATH expression is used only to fetch the result of the lookup. This applies for XML and XPATH parameters too. Do not extend the current behavior of the XPATH expression to extract a part of the result or modify the result.