

# JD Edwards EnterpriseOne Applications

---

## **Fulfillment Management Implementation Guide**

9.2

Copyright © 2011, 2022, Oracle and/or its affiliates.

This software and related documentation are provided under a license agreement containing restrictions on use and disclosure and are protected by intellectual property laws. Except as expressly permitted in your license agreement or allowed by law, you may not use, copy, reproduce, translate, broadcast, modify, license, transmit, distribute, exhibit, perform, publish, or display any part, in any form, or by any means. Reverse engineering, disassembly, or decompilation of this software, unless required by law for interoperability, is prohibited.

The information contained herein is subject to change without notice and is not warranted to be error-free. If you find any errors, please report them to us in writing.

If this is software or related documentation that is delivered to the U.S. Government or anyone licensing it on behalf of the U.S. Government, then the following notice is applicable:

U.S. GOVERNMENT END USERS: Oracle programs (including any operating system, integrated software, any programs embedded, installed or activated on delivered hardware, and modifications of such programs) and Oracle computer documentation or other Oracle data delivered to or accessed by U.S. Government end users are "commercial computer software" or "commercial computer software documentation" pursuant to the applicable Federal Acquisition Regulation and agency-specific supplemental regulations. As such, the use, reproduction, duplication, release, display, disclosure, modification, preparation of derivative works, and/or adaptation of i) Oracle programs (including any operating system, integrated software, any programs embedded, installed or activated on delivered hardware, and modifications of such programs), ii) Oracle computer documentation and/or iii) other Oracle data, is subject to the rights and limitations specified in the license contained in the applicable contract. The terms governing the U.S. Government's use of Oracle cloud services are defined by the applicable contract for such services. No other rights are granted to the U.S. Government.

This software or hardware is developed for general use in a variety of information management applications. It is not developed or intended for use in any inherently dangerous applications, including applications that may create a risk of personal injury. If you use this software or hardware in dangerous applications, then you shall be responsible to take all appropriate fail-safe, backup, redundancy, and other measures to ensure its safe use. Oracle Corporation and its affiliates disclaim any liability for any damages caused by use of this software or hardware in dangerous applications.

Oracle and Java are registered trademarks of Oracle and/or its affiliates. Other names may be trademarks of their respective owners.

Intel and Intel Inside are trademarks or registered trademarks of Intel Corporation. All SPARC trademarks are used under license and are trademarks or registered trademarks of SPARC International, Inc. AMD, Epyc, and the AMD logo are trademarks or registered trademarks of Advanced Micro Devices. UNIX is a registered trademark of The Open Group.

This software or hardware and documentation may provide access to or information about content, products, and services from third parties. Oracle Corporation and its affiliates are not responsible for and expressly disclaim all warranties of any kind with respect to third-party content, products, and services unless otherwise set forth in an applicable agreement between you and Oracle. Oracle Corporation and its affiliates will not be responsible for any loss, costs, or damages incurred due to your access to or use of third-party content, products, or services, except as set forth in an applicable agreement between you and Oracle.

# Contents

<b>Preface</b>	<b>i</b>
<b>1 Introduction to JD Edwards EnterpriseOne Fulfillment Management</b>	<b>1</b>
JD Edwards EnterpriseOne Fulfillment Management Overview	1
JD Edwards EnterpriseOne Fulfillment Management Business Process	3
JD Edwards EnterpriseOne Fulfillment Management Integrations	5
JD Edwards EnterpriseOne Fulfillment Management Implementation	8
<b>2 Configuring the JD Edwards EnterpriseOne Fulfillment Management System</b>	<b>13</b>
Understanding Configuration of the JD Edwards EnterpriseOne Fulfillment Management System	13
Activating the JD Edwards EnterpriseOne Fulfillment Management System	13
Running the Fulfillment Management Setup Report (R4277706)	16
Setting Up Advanced Preferences for JD Edwards EnterpriseOne Fulfillment Management	17
<b>3 Entering Orders into Fulfillment Processing</b>	<b>23</b>
Understanding Sales Order Processing with the JD Edwards EnterpriseOne Fulfillment Management System	23
Setting Up Sales Order Entry (P4210) to Process Fulfillment Orders	35
Running the Fulfillment Entry Batch Processing Report (R4277704)	40
<b>4 Scoring Order Detail Lines</b>	<b>41</b>
Understanding Scoring Order Detail Lines	41
Setting Up Customer Priority	42
Setting Up Advanced Preference Scoring Details	43
Setting Up Basic Scoring Information	48
Running the Sales Order Score Batch Processing Report (R4277702)	53
<b>5 Setting Up and Processing Service Level Rules</b>	<b>57</b>
Setting Up Service Level Rules	57
Processing Service Level Rules at Sales Order Entry	66

Running Service Level Rules Update (R4277705)	73
Overriding Service Level Rules	75

## **6 Auto Fulfillment Processing 79**

---

Understanding Auto Fulfillment Processing	79
Setting Up Fulfillment Rules	82
Setting Up Fulfillment Rounding	87
Running the Auto Fulfillment Processing Report (R4277701)	90
Running the Auto Fulfillment Load Balance Report (R4277711)	92
Running the Purge Fulfillment Plan ID Report (R4277710)	93

## **7 Using the Fulfillment Workbench 95**

---

Understanding the Fulfillment Workbench	95
Setting Processing Options for the Fulfillment Workbench Program (P4277701)	96
Working with the Fulfillment Workbench	98

## **8 Releasing Order Lines from Fulfillment 105**

---

Understanding Release from Fulfillment	105
Understanding Fulfillment Message Notification	105
Setting Up Fulfillment Message Notifications	106
Running the Release from Fulfillment report (R4277703)	107
Running the Remove Unreleased Lines from Shipments Report (R4277707)	109

## **9 Appendix A - Scoring Examples 111**

---

Basic Scoring Example	111
Advance Preference Scoring	113

## **10 Appendix B - Scenarios for Shipment Consolidation Mode 121**

---

Scenario 1: Multiple Order Consolidation Mode	121
Scenario 2: Single Order Consolidation Mode	123
Scenario 3: Transactional Consolidation Mode	125
Scenario 4: No Consolidation Mode	127

<b>Index</b> .....	<b>131</b>
--------------------	------------

# Preface

Welcome to the JD Edwards EnterpriseOne documentation.

## Documentation Accessibility

For information about Oracle's commitment to accessibility, visit the Oracle Accessibility Program website at <http://www.oracle.com/pls/topic/lookup?ctx=acc&id=docacc>.

## Access to Oracle Support

Oracle customers that have purchased support have access to electronic support through My Oracle Support. For information, visit <http://www.oracle.com/pls/topic/lookup?ctx=acc&id=info> or visit <http://www.oracle.com/pls/topic/lookup?ctx=acc&id=trs> if you are hearing impaired.

## Related Information

For additional information about JD Edwards EnterpriseOne applications, features, content, and training, visit the JD Edwards EnterpriseOne pages on the JD Edwards Resource Library located at:

<http://learnjde.com>

## Conventions

The following text conventions are used in this document:

Convention	Meaning
<b>Bold</b>	Boldface type indicates graphical user interface elements associated with an action or terms defined in text or the glossary.
<i>Italics</i>	Italic type indicates book titles, emphasis, or placeholder variables for which you supply particular values.
<b>Monospace</b>	Monospace type indicates commands within a paragraph, URLs, code examples, text that appears on a screen, or text that you enter.
<b>&gt; Oracle by Example</b>	Indicates a link to an Oracle by Example (OBE). OBEs provide hands-on, step-by-step instructions, including screen captures that guide you through a process using your own environment. Access to OBEs requires a valid Oracle account.



# 1 Introduction to JD Edwards EnterpriseOne Fulfillment Management

## JD Edwards EnterpriseOne Fulfillment Management Overview

JD Edwards EnterpriseOne Fulfillment Management addresses situations in which enterprises cannot fulfill all of the orders for their products. Their product supply may be less than the demand or manufacturing planning may not occur until the demand is known. Fulfillment Management can also help when there is variability in the manufacturing process. Enterprises have contractual arrangements or service levels with their customers regarding the performance around fulfillment. These rules may include line and order fill rates, number of shipments, and a cancellation policy for open orders.

The purpose of the JD Edwards EnterpriseOne Fulfillment Management system is to fulfill orders in accordance with criteria agreed upon between you and your customers. The JD Edwards EnterpriseOne Fulfillment Management system fulfills orders based upon criteria that you set, which enables you to:

- Generate priority order scores and then match available inventory to open orders.
- Use service level rules to define fill rates for customer orders and ensure compliance with stated fill rates before releasing orders.
- Implement an automated process that fulfills inventory to orders based on the rules.
- Review the fulfillment quantities and make necessary changes.

The JD Edwards EnterpriseOne Fulfillment Management system significantly reduces or eliminates backorders that occur because of inventory availability issues. The Fulfillment Management system expects very little fluctuation in inventory availability between the time the system releases order from fulfillment and subsequent hard commitment, picking, and shipping.

## Features

This table describes features of JD Edwards EnterpriseOne Fulfillment Management:

Feature	Description
Order line selection	You can determine the types of order lines that the system enters into the fulfillment process.
Score	You can use basic scoring or advanced preference scoring to determine the score of order lines that is used in the fulfillment process.
Service level rules	You can specify how the system fulfills inventory for your customers by setting up service level rules. You can also override service level rules.

Feature	Description
Rule evaluation	The system uses the rule evaluation flag to determine whether a material change has occurred which affects whether the service level rule requirements are met for the order line. This flag enables you to review changes that occur when sales orders are updated.
Auto fulfillment	You can run a batch process that assigns inventory to open sales order lines based on the score or other predefined criteria. You can schedule the Auto Fulfillment Processing report (R4277701) to run periodically to best fit your business needs.
Fulfillment rules	You can specify how the system assigns inventory by setting up rules based on score and inventory levels.
Auto fulfillment load balancer	Based on the number of concurrent auto-fulfillment processes that you specify, the system evenly divides the sales order lines selected for processing.
Fulfillment workbench	The fulfillment workbench enables you to adjust the inventory assigned to sales order lines interactively.
Release from fulfillment	The system validates that all rules have been met before moving the order lines to the next step in the sales order process.
Unfilled notification	You can set up the system to send notification messages when quantity is unfulfilled.

## Benefits

The JD Edwards EnterpriseOne Fulfillment Management system drives operational improvements that help you manage supply, improve customer service, and decrease administrative costs.

The following table categorizes the benefits of using the JD Edwards EnterpriseOne Fulfillment Management system by operational area:

Operational Area	Benefit
Supply Management	<ul style="list-style-type: none"> <li>• Prioritize sales order lines. Prioritization criteria for sales orders lines determines how inventory is assigned which improves the ability to manage the supply of items.</li> <li>• Assign inventory based on priority and service level rules.</li> <li>• Assign partial quantities based on inventory levels.</li> <li>• Cancel open balance quantities.</li> <li>• Each sales order line can follow a different path through the sales order fulfillment cycle.</li> <li>• Fulfillment rules enable inventory assignments based on score of the sales order line and safety stock levels of items.</li> <li>• Increase flexibility for inventory assignments enables more effective management of limited supply items.</li> </ul>



Operational Area	Benefit
Customer Service	<ul style="list-style-type: none"> <li>• Improve order and line fill rates for priority customers. Scoring creates the ability to priority rank customer sales order lines based on five factors.</li> <li>• Enforce targeted service levels.</li> <li>• Reduce late orders for priority customers.</li> <li>• Reduce back orders and lost sales.</li> <li>• Track reasons for overriding standard service level rules.</li> <li>• Increase customer satisfaction by decreasing backorders and lost sales due to inventory availability.</li> <li>• Increase customer satisfaction with flexibility to interactively revise inventory assignments to sales order lines for stock items and kit parents.</li> <li>• Enforce service level agreement information during the sales order fulfillment cycle.</li> <li>• Increase customer satisfaction due to proactive discussion of order fulfillment status.</li> </ul>
Administrative Costs	<ul style="list-style-type: none"> <li>• Enforce fill rates automatically.</li> <li>• Reduce costly penalty fees and fines.</li> <li>• Cancel open balances automatically based on rules.</li> <li>• Reduce transportation costs by enforcing number of releases (shipments).</li> <li>• Streamline administrative tasks by maintaining central control over service level information and integrating the rules into the sales order fulfillment cycle reduces the amount paid in penalty fees for noncompliance.</li> </ul>

## JD Edwards EnterpriseOne Fulfillment Management Business Process

This diagram illustrates the JD Edwards EnterpriseOne Fulfillment Management business process:

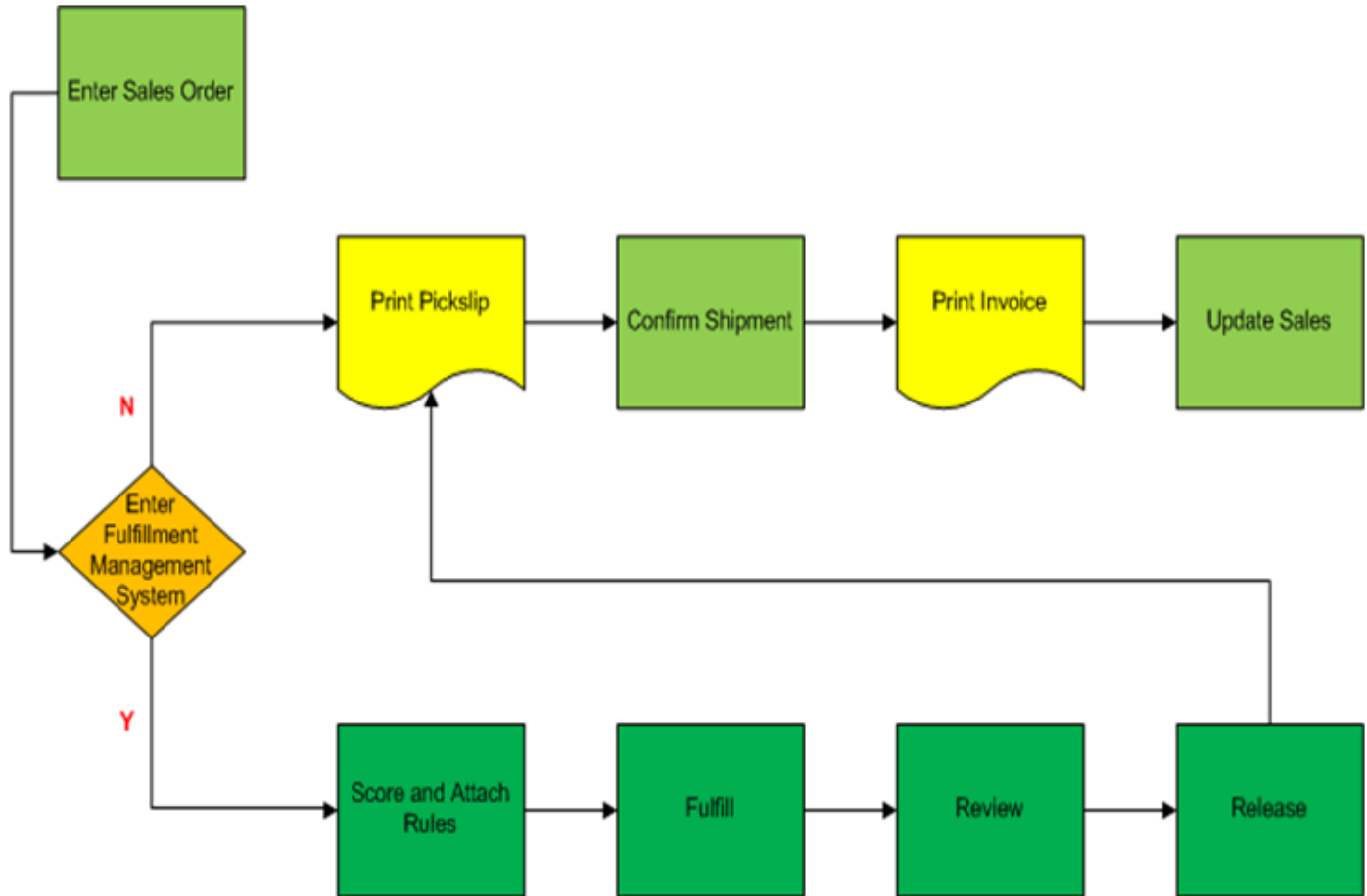

The standard sales order management process includes five basic steps:

1. Enter sales orders.
2. Print pick slips.
3. Confirm shipments.
4. Print invoices.
5. Update sales.

Typically, when you enter a sales order, the system performs availability checking for items and then commits inventory to the items. Because item availability checking occurs during sales order entry, the system commits inventory using a first-in, first-served model. The JD Edwards EnterpriseOne Fulfillment Management system enables you to bypass

availability checking at sales order entry and defer soft commitments against inventory. The fulfillment process integrates seamlessly within the sales order management process while not affecting the downstream processes for sales orders.

The fulfillment process also has five steps:

1. **Select.** Based upon advanced preference 41 (Fulfillment Entry) setup, the system determines whether a sales order line enters the fulfillment process. Factors that help determine whether the system enters a sales order line into the fulfillment process include document type, item, item group, customer, and customer group.

**Note:** The system does not enter all orders lines into the fulfillment process unless you setup advanced preference 41 to do so.

2. **Score and attach rules.** You assign scores to order lines based upon user-defined setup. Scoring helps to determine the fulfillment priority. Scoring is an optional step in the process.

The system uses two methods to score orders. You can set up advanced preferences to calculate weighted scores or use basic scoring to assign the priority.

3. **Fulfill.** This automated process assigns available inventory to orders based upon the priority criteria that you set up.

The fulfill process can be iterative. You can run the process over the same orders multiple times until you have a plan to implement.

4. **Review.** You can interactively review the system-generated fulfillment plan and modify it as necessary.
5. **Release.** This batch process moves the lines to the next step in the sales order process (for example, print pick slip). The system can notify a user-defined party when the order lines are not completely filled.

The JD Edwards EnterpriseOne Fulfillment Management system should significantly reduce or eliminate backorders that occur due to limited availability of items. The system is intended to process inventory commitments before sending sales orders to the warehouse for picking and shipping. Ideally, you should have limited fluctuation in item availability from the time order lines are released from fulfillment and processed by the warehouse.

## JD Edwards EnterpriseOne Fulfillment Management Integrations

The JD Edwards EnterpriseOne Fulfillment Management system integrates with these JD Edwards EnterpriseOne products:



**Sales Order  
Management**



**Warehouse  
Management**



**Transportation  
Management**



**Fulfillment  
Management**



**Address Book**



**Inventory  
Management**



**Demand  
Scheduling  
Execution**



**EDI**



**Advanced Pricing**

The JD Edwards EnterpriseOne Fulfillment Management system works with other distribution and logistics systems to ensure that customer demand is met. Supply and demand components must balance to ensure that demand is met. The key to success is integration and the proactive use of distribution and logistics information.

## JD Edwards EnterpriseOne Address Book

The JD Edwards EnterpriseOne Address Book system from Oracle stores current customer information, such as address, contact information, phone and fax numbers, billing instructions, and default shipping and invoicing information.

## JD Edwards EnterpriseOne Advanced Pricing

JD Edwards EnterpriseOne Advanced Pricing enables you to group customers and items so you can accommodate different market sectors and product lines; you do not have to define adjustments for each item or customer. You can define price groups by customers, items, customer groups, or item groups. You also can identify customers by Sold To, Ship To, or Parent addresses.

## JD Edwards EnterpriseOne Data Interface for Electronic Data Interchange

The JD Edwards EnterpriseOne Data Interface for Electronic Data Interchange (EDI) system (code 47) acts as a staging area for moving data in and out of the JD Edwards EnterpriseOne system. In addition to exchanging EDI data, you can use this data interface for general interoperability and electronic commerce needs when a file-based interface meets business requirements.

## JD Edwards EnterpriseOne Demand Scheduling Execution

You use the JD Edwards EnterpriseOne Demand Scheduling system to manage requirements for shipment and production schedules between customers and suppliers. Firm or planned demand requirements enable you to receive, interpret, validate, or forecast net order information for shipments and to automatically communicate shipment details to the supplier or customer. The system interprets and receives information using EDI documents that are transmitted from customers to suppliers, and then populates the appropriate demand scheduling tables to create records, sales orders, and forecasts. You set up the demand scheduling system to manage all of this information.

## JD Edwards EnterpriseOne Inventory Management

The JD Edwards EnterpriseOne Inventory Management system from Oracle stores item information for the JD Edwards Fulfillment Management, Sales Order Management, Procurement, Manufacturing, and Supply Chain Management systems from Oracle. JD Edwards EnterpriseOne Inventory Management also stores sales and purchasing costs and quantities available by location and tracks holds for locations from which items should not be sold. Any change in inventory valuation, count variances, or movement updates the general ledger.

## JD Edwards EnterpriseOne Sales Order Management

You can enhance customer service by using the JD Edwards EnterpriseOne Sales Order Management system to create order templates and recurring or blanket orders. Also, this system provides additional customer service support through online displays that provide:

- Pertinent order, inventory, transportation, and financial information.
- Net profitability of a product line when promotions, discounts, and allowances are applied.

## JD Edwards EnterpriseOne Transportation Management

You can integrate the JD Edwards EnterpriseOne Sales Order Management and JD Edwards Fulfillment Management systems with the JD Edwards EnterpriseOne Transportation Management system from Oracle to provide carrier and shipment functionality.

## JD Edwards EnterpriseOne Warehouse Management

JD Edwards EnterpriseOne Warehouse Management is an integral part of manufacturing and distribution processes. It works with other JD Edwards EnterpriseOne systems to manage inventory and the products that companies produce and ship.

# JD Edwards EnterpriseOne Fulfillment Management Implementation

This section lists the steps that are required to implement the JD Edwards EnterpriseOne Fulfillment Management system globally, sales specifically, and application specifically.

## Other Sources of Information

In the planning phase of the implementation, take advantage of all Oracle sources of information, including the installation guides and troubleshooting information.

When determining which electronic software updates (ESUs) to install for JD Edwards EnterpriseOne Fulfillment Management, use the EnterpriseOne and World Change Assistant. EnterpriseOne and World Change Assistant, a Java-based tool, reduces the time required to search and download ESUs by 75 percent or more and enables you to install multiple ESUs simultaneously.

### Note:

- [JD Edwards EnterpriseOne Tools Software Updates Guide](#) .

## Global Implementation Steps

The suggested global implementation steps for JD Edwards EnterpriseOne Fulfillment Management:

1. Set up global user-defined codes (UDCs).  
*See "JD Edwards EnterpriseOne Tools System Administration Guide."*
2. Set up companies, fiscal date patterns, and business units.  
*See "Setting Up Organizations" in the JD Edwards EnterpriseOne Applications Financial Management Fundamentals Implementation Guide.*
3. Set up next numbers.  
*See "Setting Up Next Numbers" in the JD Edwards EnterpriseOne Applications Financial Management Fundamentals Implementation Guide.*
4. Set up accounts and a chart of accounts.  
*See "Creating the Chart of Accounts" in the JD Edwards EnterpriseOne Applications Financial Management Fundamentals Implementation Guide.*
5. Set up General Accounting constants.  
*See "Setting Up the General Accounting System" in the JD Edwards EnterpriseOne Applications General Accounting Implementation Guide.*
6. Set up multi-currency processing, including currency codes and exchange rates.
  - o *See "Setting Up General Accounting for Multicurrency Processing" in the JD Edwards EnterpriseOne Applications Multicurrency Processing Implementation Guide.*
  - o *See "Setting Up Exchange Rates" in the JD Edwards EnterpriseOne Applications Multicurrency Processing Implementation Guide.*
7. Set up ledger type rules.  
*See "Setting Up Ledger Type Rules for General Accounting" in the JD Edwards EnterpriseOne Applications General Accounting Implementation Guide.*
8. Enter address book records.  
*See "Entering Address Book Records" in the JD Edwards EnterpriseOne Applications Address Book Implementation Guide.*
9. Set up inventory information such as branch/plant constants, default locations and printers, manufacturing and distribution AAls, and document types.  
*See "Setting Up the Inventory Management System" in the JD Edwards EnterpriseOne Applications Inventory Management Implementation Guide.*
10. Set up shop floor calendars.  
*See "Setting Up Shop Floor Calendars" in the JD Edwards EnterpriseOne Applications Shop Floor Management Implementation Guide.*
11. Set up order activity rules.  
*See "Setting Up Order Activity Rules" in the JD Edwards EnterpriseOne Applications Sales Order Management Implementation Guide.*

## Sales-Specific Implementation Steps

The required implementation steps to use the JD Edwards EnterpriseOne Fulfillment Management and Sales Order Management systems:

1. Set up UDCs for JD Edwards EnterpriseOne Sales Order Management.  
*See "Setting Up UDCs" in the JD Edwards EnterpriseOne Applications Sales Order Management Implementation Guide .*
2. Set up constants.  
*See "Setting Up Constants" in the JD Edwards EnterpriseOne Applications Sales Order Management Implementation Guide .*
3. Set up AAls for JD Edwards EnterpriseOne Sales Order Management.  
*See "Setting Up AAls for Sales Order Management" in the JD Edwards EnterpriseOne Applications Sales Order Management Implementation Guide .*
4. Set up commission information.  
*See "Setting Up Commission Information" in the JD Edwards EnterpriseOne Applications Sales Order Management Implementation Guide .*
5. (Optional) Create order templates.  
*See "Creating Order Templates" in the JD Edwards EnterpriseOne Applications Sales Order Management Implementation Guide .*
6. Set up order hold information.  
*See "Setting Up Order Hold Information" in the JD Edwards EnterpriseOne Applications Sales Order Management Implementation Guide .*
7. (Optional) Set up self-service information.  
*See "Setting Up Self-Service Information for Sales Order Management" JD Edwards EnterpriseOne Applications Sales Order Management Implementation Guide .*
8. Set up customer billing instructions.  
*See "Setting Up Customer Information" JD Edwards EnterpriseOne Applications Sales Order Management Implementation Guide .*
9. Set up UCC 128 compliance information.  
*See "Setting Up UCC 128 Compliance" JD Edwards EnterpriseOne Applications Sales Order Management Implementation Guide .*
10. Set up base prices, base pricing structures, complex price groups, and standard price adjustments.  
*See "Setting Up Base and Standard Pricing" JD Edwards EnterpriseOne Applications Sales Order Management Implementation Guide .*
11. Set up return material authorization defaults and return material authorizations.  
*See "Generating Returned Material Authorization" JD Edwards EnterpriseOne Applications Sales Order Management Implementation Guide .*



**12.** Set up basic and advanced preferences.

See *"Activating Preferences" in the JD Edwards EnterpriseOne Applications Sales Order Management Implementation Guide*.

## Application-Specific Implementation Steps

This table lists the required implementation steps for the JD Edwards EnterpriseOne Fulfillment Management system:

**1.** Activate the JD Edwards EnterpriseOne Fulfillment Management system.

See *Activating Fulfillment Management*.

**2.** Set up Fulfillment Management (advanced preference 41).

See *Setting Up Preference Detail Values for Fulfillment Entry (41)*.

**3.** (Optional) Set up fulfillment rules.

See *Setting Up Fulfillment Rules*.

**4.** (Optional) Set up service level rules.

See *Setting Up Service Level Rules*.

**5.** (Optional) Set up advanced preference scoring.

See *Setting Up Advanced Preference Scoring Details*.

**6.** (Optional) Set up basic scoring.

See *Setting Up Basic Scoring Information*.

**7.** (Optional) Set up rounding rules.

See *Setting Up Fulfillment Rounding*.

**8.** (Optional) Set up message notification.

See *Setting Up Fulfillment Message Notifications*.



# 2 Configuring the JD Edwards EnterpriseOne Fulfillment Management System

## Understanding Configuration of the JD Edwards EnterpriseOne Fulfillment Management System

Before you use JD Edwards EnterpriseOne Fulfillment Management, you must define information that the system uses during fulfillment processing. The system setup for JD Edwards EnterpriseOne Fulfillment Management enables you to configure the system for your business needs and to set up default values that can save you time when processing transactions. The initial setup has three steps:

1. Run the Fulfillment Management Setup report (R4277706).
2. Activate the Fulfillment Management system using the OneWorld System Control program (P99410).
3. Set up Fulfillment Management advanced preferences.

## Activating the JD Edwards EnterpriseOne Fulfillment Management System

This section provides an overview and discusses how to:

- Insert setup data into the JD Edwards EnterpriseOne system.
- Activate Fulfillment Management.

## Understanding JD Edwards EnterpriseOne Fulfillment Management Activation

Before you can use the JD Edwards EnterpriseOne Fulfillment Management system, you must activate it within JD Edwards EnterpriseOne. Upon activation, the system creates the links between the JD Edwards EnterpriseOne Sales Order Management, Inventory Management, Transportation Management, Warehouse Management, and Fulfillment Management systems. Specifically, when you create a sales order the system initiates order processing based on the setup in these various systems.

## Inserting Setup Data into the JD Edwards EnterpriseOne System

You must run the Fulfillment Management Setup report (R4277706) to insert data setup records into the Preference Values Definition table (F40711) and the OneWorld System Control File table (F99410). If the system cannot insert data into the respective tables because the preference exists, the system displays an error message in the PDF document.

## Set Up Data Records for Advanced Preferences

When you run the Fulfillment Management Setup report, the system inserts setup data records for five advanced preference types into the Preference Values Definition table (F40711).

The data records contain driver and return fields that are necessary for fulfillment processing. For example, the Fulfillment Management preference (41) uses the Document Type field (DCTO) as a driver to determine whether the system considers a sales order for fulfillment processing. If the document type is set up in the preference, then the system returns a value to the In Fulfillment field (ALLOC) in the Sales Order Detail table (F4211). The ALLOC field must be populated with **1** (Yes) for the JD Edwards EnterpriseOne Fulfillment Management system to process the sales order line.

This table lists the driver and return fields for each advanced preference:

Advanced Preference Type	Description	Driver Fields	Return Fields
41	Fulfillment Management	Order Type (DCTO)	Allocation Process Flag (ALLOC)
42	Order Type Priority	Order Type (DCTO)	Order Type Priority (OTPRIO)
43	Line Type Priority	Line Type (LNTY)	Line Type Priority (LTPRIO)
44	Requested Date Age Priority		Requested Date Age Days (OADAYS) Requested Date Age Priority (OAPRIO)
45	Rounding Fulfillment	Transaction is Equal to Primary (FMTRPR) Business Unit (MCU)	Fulfillment Rounding Rule (FMRUND)

## Setup Data Record for the OneWorld System Control File Table

When you run the Fulfillment Management Setup report, the system also inserts a single setup data record into the OneWorld System Control File table (F99410). The system uses data item SY42W to activate the JD Edwards EnterpriseOne Fulfillment Management system.

**Note:** Initially, the Module Exists field is blank until you activate the Fulfillment Management system.

## Form Used to Activate Fulfillment Management

**Note:** After running the Fulfillment Management Setup report, you must access the EnterpriseOne System Control program (P99410) to activate the JD Edwards EnterpriseOne Fulfillment Management system.

Form Name	Form ID	Navigation	Usage
EnterpriseOne System Control - Revisions	W99410B	Enter <b>P99410</b> in the Fast Path field and click the Go button.  On the Work With EnterpriseOne System Control form, locate and select data item SY42W.  Select <b>Yes</b> to activate Fulfillment Management.	Activate Fulfillment Management.

## Activating Fulfillment Management

Access the EnterpriseOne System Control - Revisions form.

**EnterpriseOne System Control - Revisions**

✓ ✗ ⚙ Tools

Data Item

Yes  No

Sequence Number

## Running the Fulfillment Management Setup Report (R4277706)

This section discusses how to run the Fulfillment Management Setup report.

### Running Fulfillment Management Setup

To run the Fulfillment Management Setup report:

1. Enter **BV** in the Fast Path field and access the Work with Batch Versions - Available Versions form.
2. Enter **R4277706** in the Batch Application field and click Find.
3. Select and run version XJDE0001.

**Note:** This report has no processing options.

# Setting Up Advanced Preferences for JD Edwards EnterpriseOne Fulfillment Management

This section provides an overview of advanced preferences and discusses how to:

- Set up preference definitions.
- Set up preference schedules.
- Set up preference details.
- Set up preference detail values for Fulfillment Entry (41).

## Understanding Advanced Preferences

You can use advanced preferences to meet complex business requirements by configuring the way the system processes sales orders. Advanced preferences enable you to use complex item and customer groups. The system processes complex groups based on category code definitions, similar to JD Edwards EnterpriseOne Advanced Pricing.

Advanced preferences use a single set of applications and definition tables, which simplifies setup and maintenance. Using advanced preferences consists of setting up one or more preference names, or types, a preference schedule, and preference details. When you set up an advanced preference, you identify specific driver fields that the preference overrides when processing a specific order. You specify the driver fields and the return value fields.

You can create a default preference schedule on the System Constants form that the system uses to resolve preferences. Optionally, you can override the default preference schedule by entering an alternate preference schedule in the processing options of the Sales Order Entry program (P4210).

The system resolves any preference that is not defined in the default or alternate advanced preference schedule using the basic preference setup. Therefore, the system enables you to set up basic preferences and advanced preferences and resolve them the way that you define the preference.

## Advanced Preference Types

A preference type, or name, is the profile created for a specific override to provide default order processing. The preference type usually agrees with the purpose of the preference.

When you set up a preference type, you assign a preference hierarchy. The preference hierarchy enables you to set up a preference for a specific item, item group, customer, customer group, or a combination of these.

In advanced preference, multiple basic preferences have been rolled up into a single advanced preference. An example of a rolled-up advanced preference is the Order Detail Defaults preference. The Order Detail Defaults preference contains several basic preferences, including Payment Terms, Pricing Unit of Measure, Revenue Business Unit, and End Use. Combining basic preferences into an advanced preference simplifies setup time and improves system processing time.

## Advanced Preference Schedules

A preference schedule contains one or more preference types and manages the way that the system processes preferences. In the schedule, you specify the sequence in which the system processes preferences. You can also specify effective dates for a schedule.

You must define the preference types and complete the preference details for each schedule.

## Advanced Preference Details

You define advanced preference details when you add preference types to preference schedules. Specifically, details are driver fields and return value fields. Driver fields are dependent on the preference hierarchy as defined in the preference types. Return value fields are user-defined processing specifications.

Advanced preference details may include groups, item and customers numbers, quantity level breaks, and units of measure. The system uses the details that you define to resolve the processing of specific instructions needed for the business requirements.

## Advanced Preference Processing

Advanced preference processing is based on a preference schedule. The preference schedule consists of one or more preference names or types. Each schedule can also contain additional details and values specific to the way you want the system to process orders.

The system validates the schedule identified in the system constants. This schedule determines which preferences the system resolves during order processing. If you set the Sales Order Entry program (P4210) Preference tab processing option Override Schedule for Advanced Preferences to override the schedule specified in the system constants, then the system uses the schedule specified for that version of the Sales Order Entry program. The system uses the schedule to find the appropriate preference names, or types, to process.

The system uses the Price Adjustment Type program (P4071) to validate how you have identified the preference. The system takes into account the preference hierarchy you have set up and the preference type. The system also determines whether to update preference history records or to process level breaks by quantity.

Next, the system uses the details you have set up for the preference. These details include groups, item and customer number, quantity level breaks, and units of measure. The details the system uses at this point also include the specific driver and return value fields that you define when you define the preference type.

This table lists the sequence in which the system processes advanced preferences:

Sequence	Preference Information	Program or Fields
1	Preference types specified in the advanced preference schedule.	P4070 - Advanced Preferences Schedule Revisions
2	Preference type specifications such as: <ul style="list-style-type: none"> <li>• Hierarchy.</li> <li>• Quantity level breaks.</li> <li>• Complex groups.</li> </ul>	P4071 - Advanced Preferences Name Revisions
3	Preference details based on: <ul style="list-style-type: none"> <li>• Preference hierarchy.</li> <li>• Customer, item group, or both, as defined in preference type.</li> </ul>	P4072 - Advanced Preference Detail Revisions
4	Driver fields	Driver fields and return value as specified in P4072.



Sequence	Preference Information	Program or Fields

See *"Setting Up Advanced Preferences" in the JD Edwards EnterpriseOne Applications Sales Order Management Implementation Guide*.

## Forms Used to Set Up Advanced Preferences for Fulfillment Management

Form Name	Form ID	Navigation	Usage
Preference Definition Revisions	W4071A	Advanced Preferences (G40311), Advanced Preferences Name Revisions  Click Add on the Work with Preference Types form.	Set up preference definitions.
Preference Schedule Revisions	W4070C	Advanced Preferences (G40311), Advanced Preferences Schedule Revisions  Click Add on the Work with Preference Schedules form.	Set up preference schedules.
Preference Detail Revisions	W4072A	Advanced Preferences (G40311), Advanced Preferences Detail Revisions  Search for a Preference Name and click Add on the Work with Preference Detail form. Select the appropriate combination and click Select on the Preference Hierarchy Selection form.	Set up preference details.
Preference Values Revisions	W4072D	Select a row and select Pref Details from the Row menu.	Set up preference detail values.

## Setting Up Preference Definitions

Access the Preference Definition Revisions form.

See *"Working with Adjustment Definitions" in the JD Edwards EnterpriseOne Applications Advanced Pricing Implementation Guide*.

### Item Group

Enter a user defined code (40/PI) that identifies an inventory price group for an item.

Inventory price groups have unique pricing structures that direct the system to incorporate discounts or markups on items on sales and purchase orders. The discounts or markups are based on the quantity, dollar amount, or weight of the item ordered. When you assign a price group to an item, the item takes on the same pricing structure defined for the inventory price group.

You must assign an inventory price group to the supplier or customer, and to the item for the system to interactively calculate discounts and markups on sales orders and purchase orders.

### Customer Group

Enter a user defined code (40/PC) that identifies a customer group. You can group customers with similar characteristics, such as comparable pricing.

### Preference Hierarchy

Enter a user-defined code (UDC) from 40/PR to identify a preference type or a price adjustment hierarchy. When you define hierarchies, you identify each table with this code. Later, when you create adjustments, you use this code to identify the hierarchy that the system follows for the adjustment.

### Quantity Level Break

Select this option to indicate level breaks to occur in the Price Adjustment Detail table (F4072). You can define three types of level breaks:

- Quantity. The system determines the correct adjustment based on the quantity ordered in the sales order. You can set up different adjustment breaks for different units of measure.
- Weight. The system uses the weight assigned to the sales order detail line item to determine the proper adjustment level break.
- Amount. The system uses the extended amount on the sales order detail line to determine the proper adjustment level break. If you activate currency conversion, the system stores and displays all amount-level breaks based on the floating decimals of the currency code.

If you select the None option, the system uses advanced preference features to determine the proper adjustment level break. Use this option only if you are using advanced preferences.

### Advanced Preference Type

Enter a UDC from 40/AP to specify how the system processes the defined advanced preference.

## Setting Up Preference Schedules

Access the Preference Schedule Revisions form.

See *"Building Adjustment Schedules" in the JD Edwards EnterpriseOne Applications Advanced Pricing Implementation Guide*.

### Preference Schedule

Enter a UDC from 40/AS to identify a price and adjustment schedule. A price and adjustment schedule contains one or more adjustment types for which a customer or an item might be eligible. The system applies the adjustments in the sequence that you specify in the schedule. You link customers to a price and adjustment schedule through customer billing instructions. When you enter a sales order, the system copies the schedule attached to the sold-to address into the order header. You can override this schedule at the detail line level.

#### Preference Name

Enter a UDC from 40/TY to identify an adjustment definition. You define adjustments in the Preference Definition program (P4071).

## Setting Up Preference Details

Access the Preference Detail Revisions form.

See *"Setting Up Adjustment Details" in the JD Edwards EnterpriseOne Applications Advanced Pricing Implementation Guide*.

#### Preference Name

Enter a UDC from 40/TY to identify an adjustment definition. You define adjustments in Price Adjustment Names.

**Note:** *On occasion, when running the Fulfillment Management Setup report (R4277706), the system may not update the Preference Value Details table (F40721). Should this occur, you must clear the server cache.*

## Setting Up Preference Detail Values for Fulfillment Entry (41)

Access the Preference Values Revisions form.

See *"Setting Up Adjustment Details" in the JD Edwards EnterpriseOne Applications Advanced Pricing Implementation Guide*.

#### Sequence

Enter a number that specifies the sequence of information.

#### Or Ty (order type)

Enter a UDC from 00/DT to identify the type of document that this preference to process. The document type field (DCTO) in the Sales Order Detail table (F4211) is the driver that determines whether the line enters the fulfillment management process.

#### In Fulfillment

Indicate whether the system flags a sales order detail line for the fulfillment management process. The system returns and stores this value in the Sales Order Detail table (F4211). The system can resolve the preference when you enter a sales order or by running the Fulfillment Entry Batch Processing report (R4277704). The system does not perform availability checking during order entry and stores the order quantity in the Future Qty Committed field (SONE) for the detail line. The system soft-commits quantities using the fulfillment processes. Values are:

**1:** The system selects the order line to go through the fulfillment process.

**0:** The system does not select the order line to go through the fulfillment process.



# 3 Entering Orders into Fulfillment Processing

## Understanding Sales Order Processing with the JD Edwards EnterpriseOne Fulfillment Management System

This section discusses:

- Fulfillment processing during sales order entry.
- Fulfillment processing and JD Edwards EnterpriseOne Inventory Management.
- Fulfillment processing and JD Edwards EnterpriseOne Demand Scheduling Execution.
- Fulfillment processing and JD Edwards EnterpriseOne Transportation Management.
- Fulfillment processing and JD Edwards EnterpriseOne Warehouse Management.
- Fulfillment processing and Oracle Transportation Management.

### Fulfillment Processing During Sales Order Entry

This section discusses how fulfillment processing works during sales order entry.

#### Order Activity Rules

The sales order statuses and order activity rules govern the processes that can be performed on sales order lines. You can set up a new status code in the order activity rules to represent the fulfillment processing step. The step should be after Enter Sales Order (520) and before Print Pickslips (540). If you use other processes between these two steps, such as approval processing or in warehouse, you must ensure the fulfillment step is sequenced appropriately.

Similar to the JD Edwards EnterpriseOne Sales Order Management programs, JD Edwards EnterpriseOne Fulfillment Management programs use processing options to increment status codes.

#### Commitment Processing

The system does not check availability or soft commit inventory for sales order lines that enter the fulfillment process.

The JD Edwards EnterpriseOne Fulfillment Management system does not process hard committed lines. If you enter a location or lot number on a detail line during sales order entry, the system issues a hard error.

An order that goes into future commitment because it is outside of the commitment date window (from the branch plant constant settings) is called *true future* functionality or *true future* order commit. This distinction is necessary to differentiate between order quantity that goes onto future commitment because of the commitment date window and order quantity that goes onto future commit from advanced preference 41. The Fulfillment Management system is designed to take the place of the true future order system. In the event that a commitment date window and advanced preference 41 are both active at order entry time, the system evaluates advanced preference 41 first, which takes precedence over any consideration of the commitment date window. You can simulate the commitment date window functionality within the Fulfillment Management system by using the requested date age scoring preference to create a score that is out of any range of consideration by the fulfillment processes until it comes within the specified

commitment window. You run the Repost Active Sales Order report (R42995) to commit true future orders to current. After the orders are current, you run the Fulfillment Management Entry (R4277704) report to enter the orders into the Fulfillment Management system.

The system stores the order quantity in the Future Qty Committed field (SONE) for sales order lines that go into the fulfillment process. The quantity in the field is not considered a *true* future commitment. The system also enters a **1** into the In Fulfillment field (ALLOC) in the Sales Order Detail table (F4211), which indicates the order line is in the fulfillment process. When the order line enters the fulfillment process, the system moves the quantity from the Quantity Shipped field (SOQS) to the Future Qty Committed field; no quantities reside in the Quantity Backordered (SOBK) or Quantity Canceled (SOCN) fields. The system does not enable you to modify the quantities in these fields. The quantity on the sales order gets moved from the Future Qty Committed field to the Quantity Shipped field using the Auto Fulfillment Processing and the Fulfillment Workbench programs. The system does not allow the Repost Active Sales Orders report (R42995) to move fulfillment orders to soft commit.

## Fulfillment Management Exclusions

The JD Edwards EnterpriseOne Fulfillment Management system does not process these types of sales orders or line items:

- Configured items and their components.
- Non-stock items.
- Blanket orders.
- Quote orders.
- Direct ship orders.
- Credit orders.
- Intercompany orders. The sales intercompany order type (SK) and the purchase intercompany order type (OK) are excluded. However the system does process interbranch sales order type (SI) through the Fulfillment Management system.
- Future orders.
- Orders entered in warehouse management processing.
- Orders that are engineered to order.
- Orders that generate a work order.
- Orders that generate a purchase order. Transfer orders can enter fulfillment based on how you set up the Fulfillment Entry advanced preference.
- Orders with quantities that have been relieved from on hand.
- Orders with inventory quantities that are hard committed.
- Backordered or canceled lines, either full or partial.
- Kits with individually processed components
- Global Order Promising eligible order lines.

If the system determines that an order line is eligible to enter into the JD Edwards EnterpriseOne Fulfillment Management system, the system then validates the override next status that you set in the processing options. If the override next status is invalid, the system sets an error and does not accept the order line into the JD Edwards EnterpriseOne Fulfillment Management system. If the next status is valid, the system:

- Updates the next status to the override next status.
- Sets the In Fulfillment field to **1** in the F4211 to indicate the line is in the fulfillment process.

- Sets the Fulfillment status to **10** (Entered).
- Moves the shippable quantity from the Quantity Shipped field (SOQS) to the Future Quantity field (SONE).
- Attaches service level rules per processing options.
- Evaluates the inventory commitment preference.
- Removes any prior fulfillment plan ID.
- Balances dual quantities.
- Scores the order if set in the processing options.
- Populates the Customer Master Company field (CMCO) with the company from the customer master.

After you enter orders into the fulfillment process, the JD Edwards Fulfillment Management system permits you to revise sales order lines. You can:

- Revise dates (only the Requested Date affects fulfillment).
- Change branch/plant in the detail line.
- Cancel lines.
- Increase or decrease order quantities.

If you change the order quantity in a sales order line, the system must reevaluate the service level rule minimum fill percent for the line and order, and set the appropriate requirement met flags.

- Replace or substitute an item.
- Place an order on hold.

After you place an order on hold, the system ceases all fulfillment processing for that order until you release the order.

- Override the service level rule information:
  - Override fill percentages for lines and orders.
  - Enter override reason codes.
  - Update the cancel flag.
- Split lines.

When the system splits a line because of using the Release From Fulfillment report (R4277703), the system resolves service level rule information for the new line.

When the system splits a line outside of the fulfillment process (from pick slip, ship confirm, and so on), the system also copies the service level rule. You can then run the Fulfillment Entry Batch Processing report (R4277704) on the split line to enter the line into fulfillment processing and resolve a new service level rule if necessary.

When you make changes, the system revises the fulfillment state of the line and the quantity commitments as required. Depending on the changes that you make to the sales order lines, the system sets the evaluation required flag to indicate that the line and order fill percents should be reevaluated.

## Fulfillment Batch Entry Processing

You can run the Fulfillment Entry Batch Processing report (R4277704) to enter open sales order lines into the fulfillment process. The system only evaluates order lines that are not currently in the fulfillment process. During the batch

process, the system evaluates the Fulfillment Entry advanced preference for each order line based upon the data selection. The system sends an error message for any order line that it does not process. The error message indicates the reason for the system not accepting the order lines into the JD Edwards EnterpriseOne Fulfillment Management system.

## Fulfillment Processing and JD Edwards EnterpriseOne Inventory Management

This section discusses how fulfillment processing works with:

- Availability calculations
- Dual unit of measure items
- Future commitment orders
- Inventory commitment preference
- Kit items
- Global Order Promising
- Partial shipments

### Availability Calculations

You define availability for each branch in the Branch/Plant Constants program (P41001). You decide what quantities are subtracted from and added to the on-hand quantity to calculate the available quantity. For the JD Edwards EnterpriseOne Fulfillment Management system, Oracle recommends that you:

- Subtract the soft committed quantities. The system uses the available quantity to determine how much to fill inventory to sales order lines. As the Fulfillment Management system soft commits sales order lines; you must subtract soft commitments from the on hand balance to keep availability accurate.
- Subtract the hard committed quantities. The system uses the available quantity to determine how much inventory to assign to sales order lines. If you do not use hard commitments in your system, it is not necessary to subtract hard commitments from the on hand balance.
- Not subtract the future committed quantities. The system uses the available quantity to determine how much to fill inventory to sales order lines. The Fulfillment Management system puts the order quantity in the future committed bucket before processing the order. If you subtract future commitments from the on hand balance, you do not have accurate availability quantities during the fulfillment process.
- Not subtract safety stock. When you use fulfillment rules to manage inventory levels with the Auto Fulfillment Processing report (R4277701), the system uses the rules to determine how much inventory to hold.
  - If you subtract safety stock from the on hand balance, you must set up a line with a value of zero in the Safety Stock Percentage field in the Fulfillment Rules Setup program (P4277720).
  - The chart on the Fulfillment Workbench program (P4277701) does not display the safety stock level if the quantity is subtracted from the on hand balance.

The Availability Checking field on the Item Master record (F4102) does not have any impact on items that go through the fulfillment process. The Auto Fulfillment Processing and the Fulfillment Workbench programs perform availability checking regardless of the setting in this field.



## Dual Unit of Measure Items

The JD Edwards EnterpriseOne Fulfillment Management system processes orders with dual unit of measure (UOM) items with either the transaction UOM or the secondary UOM. The processed quantities are based on their conversions.

## Inventory Commitment Preference

The JD Edwards EnterpriseOne Fulfillment Management system can process order lines that use the Inventory Commitment Preference. The system validates that the order line meets the specified percent to fill in the preference before releasing the order from fulfillment.

If the system is set up to perform fulfillment processing during order entry, the system uses a modified version of the Inventory Commitment Preference because the system does not check inventory availability. Therefore, the available inventory cannot determine the branch to be selected from the preference. The system cannot split lines based on the percent to fill for each of the branch/plant because inventory availability is not being checked. Also, instead of performing a hard commit to the sales detail, the system leaves the line as a soft commit and sets the indicator that the line is in the fulfillment process.

To use the modified version of the Inventory Commitment Preference, you must define only one line in the preference setup. The system uses the preference in the following way:

- If the Percent to Fill field on the line equals zero, the system populates the branch/plant in the detail line of the sales order with the source branch from the preference. You can perform a first-pass fulfillment and assign the detail branch based on the preference; for example, the branch that is closest to the customer's ship-to location.
- If the Business Unit field on the line is blank, the system stores the percent to fill value in the Sales Order Detail table (F4211) and validates this value during auto fulfillment processing, on the fulfillment workbench, and during release from fulfillment.
  - If both the Business Unit and Percent to Fill fields are populated, the system populates the branch/plant on the detail line and stores the percent to fill value in the Sales Order Detail table and validates this value during auto fulfillment processing, on the fulfillment workbench, and during release from fulfillment.

If the preference is set up with multiple lines, the system does not store the percent to fill in the Sales Order Detail table. When this situation occurs, these conditions apply:

- If the Percent to Fill field on the first line equals zero, the system populates the branch/plant in the detail line of the sales order with the source branch from the preference.
- If the Percent to Fill field on the first line is greater than zero, the system does not use any of the preference information. The system is not checking availability and therefore cannot determine which line of the preference to apply.

When you run the Auto Fulfillment Processing report (R4277701), the system validates the fill percent and assigns inventory to meet the fill percent requirement. If the system cannot meet the fill percent requirement, it fulfills the line and sets a warning message. Use the Fulfillment Workbench program (P4277701) to change the fulfillment quantities and validate that each line meets the fill percent.

**Note:** The service level rule information takes precedence over the fill percent from the Inventory Commitment preference information. The system does not resolve the Inventory Commitment Preference for kit parent or component items.

## Kit Items

The JD Edwards EnterpriseOne Fulfillment Management system does not use the Auto Fulfillment Processing report to assign inventory to kits. However, you can use the Fulfillment Workbench program to interactively fulfill kit parent

items. The system scores the parent and assigns this score to all of the kit components. When you locate and select a kit parent on the Fulfillment Workbench browse form, the system displays all components on the edit form and marks the components with a minus sign in the grid, thus disabling the component lines. The system also displays a notification when inventory is available for a component in another branch by placing a green check mark in the line.

You can use the Fulfillment Workbench program to perform these actions:

- Change fulfillment quantity on kit parent. The system balances the filled quantities of the kit components based on the parent to child ratio and updates the components accordingly.
- Change the promised delivery date of the parent.
- View item availability for components when you click the grid line.
- Access the Summary Availability (P41202) and Supply and Demand (P4021) programs for kit components.

You cannot change the branch plant for the parent or any component.

**Note:** The system only processes service level rules information against the kit parent item.

See *Setting Up Service Level Rules*.

## Global Order Promising

When you create or modify sales order details, the Global Order Promising system calculates a promised date for the order by taking into account inventory levels of previously promised orders and other factors, which include:

- Existing promised sales orders in the JD Edwards EnterpriseOne system.
- The expectation of those orders being in a soft or hard commitment status.
- Adhering to the promised dates for subsequent shipping.

The Fulfillment Management system manages the commitment statuses and subsequent promised dates for shipping and thus conflicts with the Global Order Promising system. Therefore, order lines that enter into the Fulfillment Management system cannot also be processed through Global Order Promising.

A sales order can include both Fulfillment Management items and Global Order Promising items.

## Partial Shipments

Partial fulfillment of a sales order line can occur when you process orders from the following programs and reports:

- Sales Order Entry (P4210).
- Fulfillment Workbench (P4277701)
- Auto Fulfillment Processing (R4277701)

When you partially fulfill an order line the system issues a warning to inform you that the Fulfillment Management system does not release order lines until the order or line percent is met; or the order line is completely fulfilled.

The system uses a soft warning instead of a hard error to enable it to maintain new and existing soft commitments. This action is critical because it allows the system to:

- Temporarily hold inventory on an order until it can add more inventory.
- Prevent lower priority orders from being fulfilled before orders with a higher priority.

The Release from Fulfillment report (R4277703) does not split partially fulfilled lines when:

- The customer does not allow partial shipments.

- The actual percent filled does not meet or exceed the percent to fill (resolved by the inventory commitment preference) or its service level fill percentages.

## Fulfillment Processing and JD Edwards EnterpriseOne Demand Scheduling Execution

The JD Edwards EnterpriseOne Fulfillment Management system processes sales orders that are processed through the JD Edwards EnterpriseOne Demand Scheduling Execution system. This diagram illustrates the process:

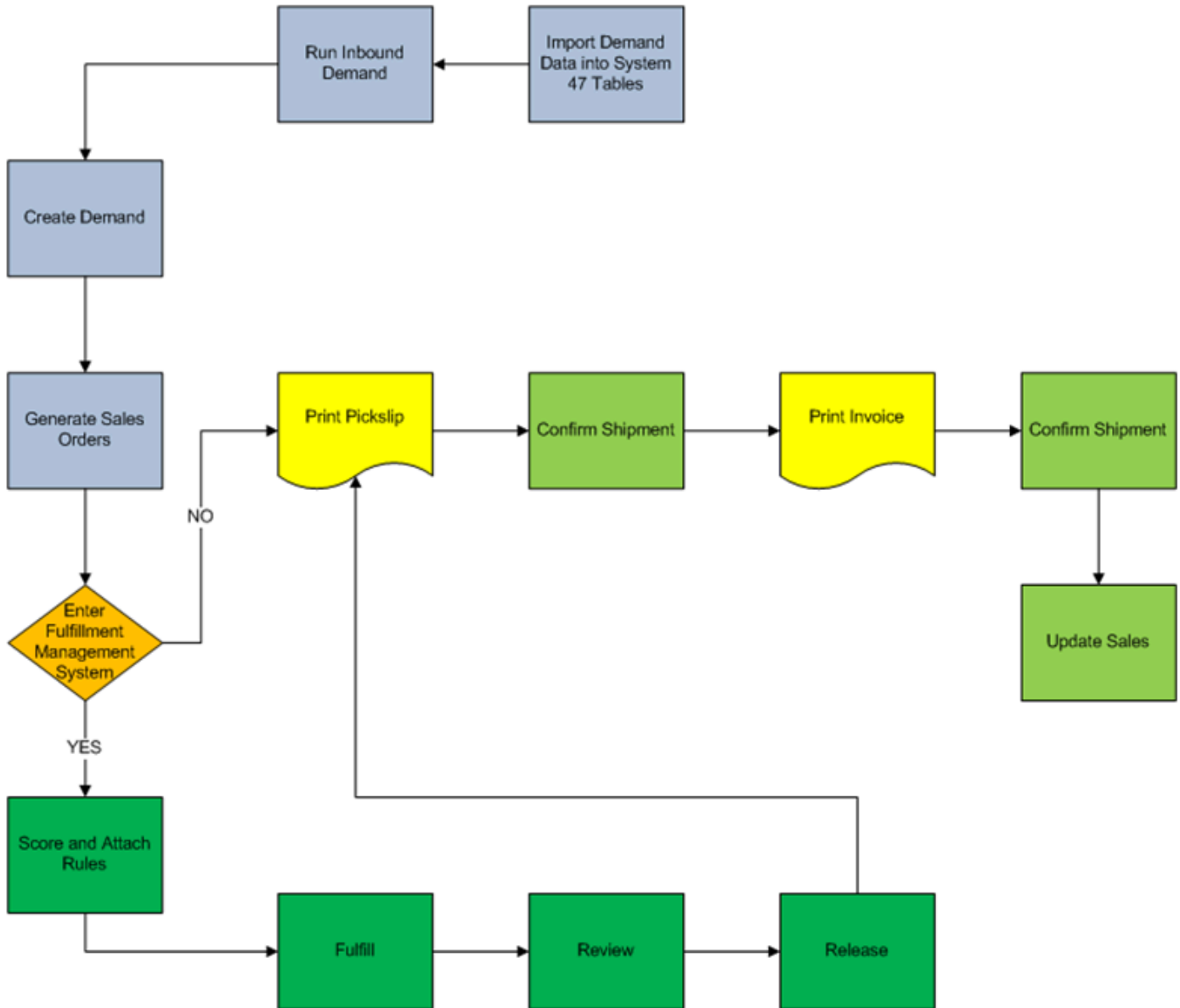

Typically, the sequence of events is:

1. Receive demand into the system 47 tables.
2. Run the EDI Inbound Demand Edit/Update report (R47171) to update the inbound demand.
3. Run the Create Demand Schedule report (R40R010) to generate sales orders.

The system enters orders into the Fulfillment Management system. You then perform the tasks within fulfillment to process the sales order lines.

4. Create shipments to meet the demand.
5. Create bills of lading for the orders.
6. Ship confirm the orders.
7. Adjust demand and populate the new cumulative shipped values into the Cum (cumulative) History tables.

## Fulfillment Processing and JD Edwards EnterpriseOne Transportation Management

The JD Edwards EnterpriseOne Fulfillment Management system processes sales orders that are processed through the JD Edwards EnterpriseOne Transportation Management system. This diagram illustrates the process:

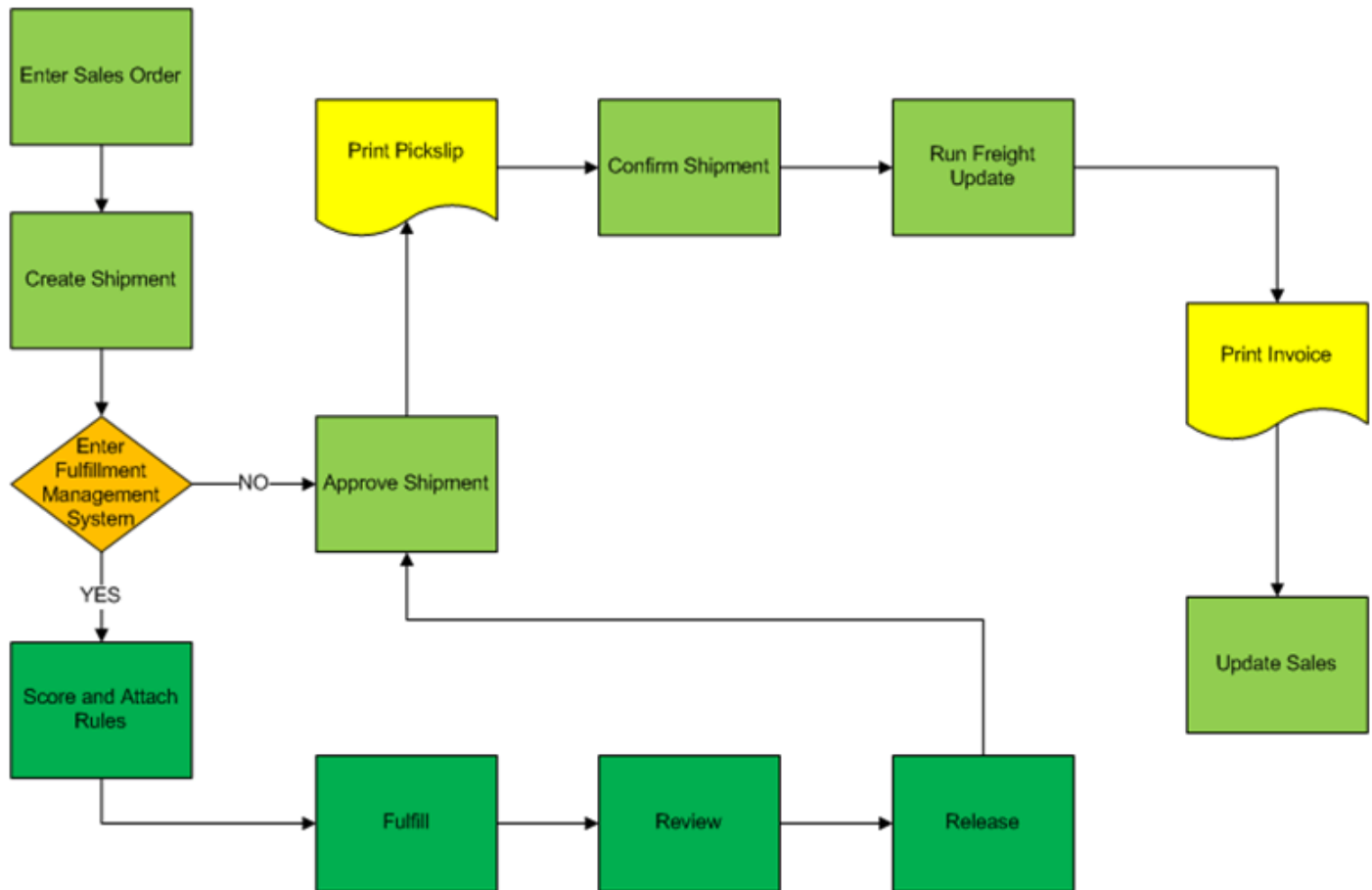

Typically, the sequence of events is:

1. Enter sales order.
2. The Transportation Management system creates shipments.
3. The system determines whether to enter the sales order lines into fulfillment processing.  
When order lines are released from fulfillment, the system adjusts the shipment quantities as appropriate to accommodate partial shipments.
4. Approve shipments.
5. Print pick slips.

6. Confirm shipments.
7. Run Freight Update.
8. Print invoices.
9. Update sales information.

When processing sales orders through the JD Edwards EnterpriseOne Transportation Management system, the system assigns shipment numbers to order lines at sales order entry. When the system does not allocate inventory to sales order lines, the unreleased sales order lines remain on the same shipment number as the released sales order lines. When this occurs, the system does not process shipments until all of the sales order lines have been released.

In order to not hold up shipments, you can activate the processing option in the Release from Fulfillment report (R4277703) to create a new shipment number for the sales order lines that remain in the fulfillment process. To ensure that shipment numbers are properly assigned to fully unreleased order lines, the Release from Fulfillment report runs a version of the Remove Unreleased Lines from Shipments report (R4277707).

See "*Running the Remove Unreleased Lines from Shipments Report (R4277707)*"

The JD Edwards EnterpriseOne Transportation Management system assigns shipment numbers to order lines based on the shipment consolidation mode that you select. See *Scenarios for Shipment Consolidation Mode*

## Fulfillment Processing and JD Edwards EnterpriseOne Warehouse Management

The JD Edwards EnterpriseOne Fulfillment Management system processes sales orders before the orders entering the JD Edwards EnterpriseOne Warehouse Management system. This diagram illustrates the process:

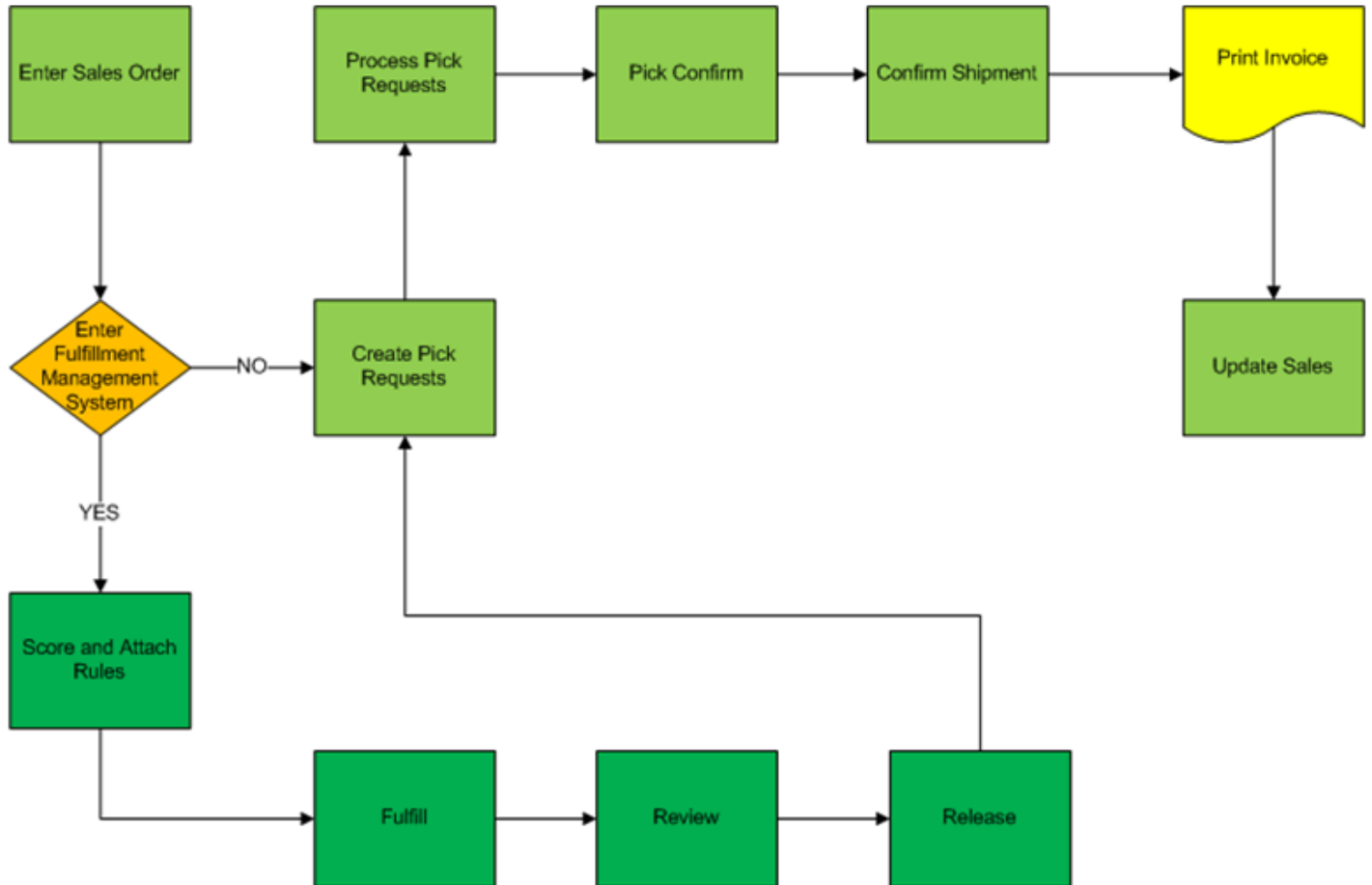

Typically, the sequence of events is:

1. Enter sales order.
2. The system determines whether to enter the sales order lines into fulfillment processing.
3. After releasing order lines from fulfillment processing, the Warehouse Management system creates pick requests.

**Note:** You must have the warehouse Request Processing Mode processing option set to blank on the Sales Order Entry program so that order lines do not enter into warehouse processing mode before fulfillment.



4. Process pick requests.
5. Confirm picks.
6. Confirm shipments.
7. Print invoices.
8. Update sales information.

## Fulfillment Processing and Oracle Transportation Management

The JD Edwards EnterpriseOne Fulfillment Management system processes sales orders that are processed through the Oracle Transportation Management integration processes:

1. The JD Edwards EnterpriseOne system enters the order into the fulfillment process.
2. The JD Edwards EnterpriseOne system processes and releases sales order lines from the fulfillment process.
3. The JD Edwards EnterpriseOne system transmits a freight request to the Oracle Transportation Management system.
4. The Oracle Transportation Management system transmits a transportation planning message to the JD Edwards EnterpriseOne system.
5. The JD Edwards EnterpriseOne system transmits a shipment confirmation message to the Oracle Transportation Management system.
6. The Oracle Transportation Management system transmits a transportation confirmation message to the JD Edwards EnterpriseOne system.
7. The JD Edwards EnterpriseOne system processes the sales order.

## Setting Up Sales Order Entry (P4210) to Process Fulfillment Orders

This section discusses the forms and processing options for sales order entry.

See

- *"Entering Sales Orders" in the JD Edwards EnterpriseOne Applications Sales Order Management Implementation Guide .*
- *"Entering Sales Orders for Customer Service Representatives" in the JD Edwards EnterpriseOne Applications Sales Order Management Implementation Guide .*
- *"Setting Processing Options for Sales Order Entry (P4210)" in the JD Edwards EnterpriseOne Applications Sales Order Management Implementation Guide .*

## Forms Used to Enter Sales Order Header and Detail Information

Form Name	Form ID	Navigation	Usage
Work With Sales Order Headers	W4210H	Sales Order Processing (G4211), Enter Orders Header	Review and select sales order header records or access forms to add a new sales order.
Sales Order Header	W4210G	Click Add on the Work With Sales Order Headers form to add a new sales order.  Select a record on the Work With Sales Order Headers form, and click Select to revise an existing sales order.	Enter sales order header information.
Sales Order Detail Revisions	W4210A	Click OK on the Sales Order Header form.	Enter sales order item information.  Enter default line information.  Review secondary UOM and quantity information for the appropriate items.  Override the default price and cost or change the values to zero.
Customer Service Inquiry	W4210E	Sales Order Processing (G4211), Sales Order Detail	Review and select sales order detail records.
Service Level Rules Inquiry/Override	W4277711A	Select a record on the Customer Service Inquiry form and click Select.  Select a record on the Sales Order Detail Revisions form.  Select Service Level Rules from the Row menu.	Review and override service level rules.  <i>See <a href="#">Setting Up Service Level Rules</a>.</i>

## Setting Processing Options for Sales Order Entry (P4210)

Use these processing options to process sales orders through the fulfillment process.

## Commitment

### 1. Check Availability

Specify whether the system verifies the available quantity for requested items. Values are:

Blank: Bypass availability checking.

**1:** Activate, notify, and backorder or cancel.

**2:** Activate, notify, but do not backorder or cancel.

If you have fulfillment processing active during sales order entry, the system does not use this processing option. If all of your items enter the fulfillment process, you can leave this processing option blank.

The Auto Fulfillment Processing and the Fulfillment Workbench programs perform availability checking regardless of the setting in this processing option.

### 2. Commit to Quantity 1 or Quantity 2

Indicate the generic buckets to which the system commits quantities. Values are:

Blank: Do not commit quantities to buckets, Other Quantity 1 or 2.

**1:** Commit quantities to Quantity 1.

**2:** Commit quantities to Quantity 2.

Leave this processing option blank for Fulfillment Management. The Fulfillment Management system stores unfulfilled quantities in the future quantity bucket and fulfilled quantities in the soft commitment bucket.

### 4. Enter Allowed Lot Status Group to validate (Release 9.2 Update)

Lot Group is the name of a user defined list of allowed non-approved lot status codes. Entry of a Lot Group name in the Processing Option will allow this Application to process lots whose lot status code is defined within the specified Lot Group Name.

When NBLOTSTS is set to **No** or NBLOTSTS is not present in the EnterpriseOne Control System program (P99410), an approved lot or location does not have a status code. All non-blank codes indicate that the lot is on hold or unapproved.

When NBLOTSTS is set to Yes, the lot status is validated by a special handling code in UDC 41/L. All codes containing the special handling code **1** indicate that the lot is approved. All codes containing special handling codes other than **1** indicate that the lot is on hold or unapproved.

**Note:** This option enables the system to increase availability for allowed lot statuses during auto fulfillment processing.

## Versions

### 26. Fulfillment Management Scoring (R4277702)

Indicate which version of the Sales Order Score Batch Processing report (R4277702) the system runs to calculate the order score when you activate the Calculate Order Score processing option on the Fulfillment Management tab. If left blank, the system runs version XJDE0001.

### 28. Service Level Rules Processor (R4277705)

Indicate which version of the Service Level Rules Update report (R4277705) the system runs to resolve service level rules when you enter sales orders or change the branch/plant on a sales order line. You must activate the Resolve Service Level Rules processing option on the Fulfillment Management tab. If left blank, the system runs version XJDE0001.

## Preference

### 2. Inventory Commitment Preference

Specify whether you want the inventory commitment preference to operate independently of other preference processing.

You use inventory commitment to specify that each order line be filled from one or more branch/plants based on customer, customer group, item, or item group. You can specify the branch/plants from which you want products shipped, determine the percentage of the order that must exist at a branch/plant before the quantity is filled at that branch/plant, or specify the mode of transportation and carrier information in the sales detail line. Values are:

Blank: The system does not use the inventory commitment preference.

**1:** Use inventory commitment preference processing only for current orders. The system performs inventory commitment preference only for those orders that are inside the commitment window of the header branch/plant. Orders that are outside the window of the header branch/plant are future committed to the header branch/plant.

**2:** Use inventory commitment preference processing for all orders. The system performs inventory commitment preference for all orders, regardless of the commitment window of the header branch/plant.

**Note:** The system uses a modified version of the Inventory Commitment Preference for order lines that enter the fulfillment process during sales order entry.

### 3. Override Schedule For Advanced Preferences

Use this processing option if you are using the Advanced Preferences function and want to specify an override preference schedule for the system to use instead of the default preference schedule that is defined in the system constants. If you are using Advanced Preferences, this schedule controls preference processing.

**Note:** Use the Advanced Preferences Schedule Revisions program (P4070) on the Advanced Preferences menu (G40311) to modify preference schedules. The Fulfillment Entry preference must be set up in the schedule for order lines to enter the fulfillment process during order entry. The system evaluates the preference only when sales orders are added. If you make changes to existing sales order lines, the system does not reevaluate the preference.

## Warehouse

### 1. Request Processing Mode

Specify whether the system creates a pick request in the Warehouse Management system. Values are:

Blank: The system does not generate pick requests.

**1:** The system generates requests only.

**2:** The system generates requests and creates the pick request through the subsystem

**Note:** Leave this processing option blank for Fulfillment Management. If a sales order enters warehouse, the lines are not eligible for fulfillment processing.

## Audit Log

### 1. Use Audit Log for Sales Order Changes

Specify whether to activate the audit logging process for sales order changes. Values are:

Blank: Do not activate audit logging.

1: Activate audit logging.

**Note:** You can override this processing option by using the Bypass Audit Logging field, which is in the Customer Billing Instructions. For example, if you set this processing option to 1 and set the Bypass Audit Logging option for the customer specified in the sales order, then the system does not perform audit logging for any order for the specified customer.

**CAUTION:** Fulfillment Management only supports blanks or option 1. If you activate this option and you are using the JD Edwards EnterpriseOne Fulfillment Management, audit logging functionality does not work with the Auto Fulfillment Processing (R4277701) and Fulfillment Entry (R4277704) reports. However, if you make changes by using the Fulfillment Workbench program (P4277701), the system creates an audit log in the Audit Log Transaction (F42420) table.

## 2. Reason Code required for Sales Order Changes

Specify whether a revision reason code is required for sales order changes. Values are:

Blank: Do not require a revision reason code.

1: Require a revision reason code.

## 3. Approval process required for Sales Order changes

Specify whether the approval process is required on the changes made to the sales order. The Use Audit Log for Sales Order Changes processing option on the Audit Log tab must be set to 1 to enable the approval process. However, you can enable audit logging without setting the Approval Process Required for Sales Order Changes processing option. When approval process is required, the system does not record changes to the order. Instead, the system retains the original values and places the order on hold. The new values are pending in the Audit Log table until an approval or rejection decision has been made. The new values are recorded for the order only if the order is approved. Values are:

Blank: The approval process is not required.

1: The approval process is required.

## Global Order Promising

### 1. Global Order Promising

Specify whether the system uses Global Order Promising to promise a delivery date for an order. Values are:

Blank: No order promising

1: Global Order Promising mode

**Note:** The system does not use this processing option for items that enter the fulfillment process. If all of your items enter the fulfillment process, you can leave this processing option blank.

## Fulfillment Management

### 1. Calculate Order Score

Specify whether the system calculates the order score during sales order entry when the Fulfillment Management system is active. Values are:

Blank: No

1: Yes

## 2. Resolve Service Level Rules

Specify whether the system resolves service level rules during sales order entry when the Fulfillment Management system is active. Values are:

Blank: No

1: Yes

# Running the Fulfillment Entry Batch Processing Report (R4277704)

This section discusses how to:

- Run the Fulfillment Entry Batch Processing report.
- Set processing options for Fulfillment Entry Batch Processing (R4277704).

## Running the Fulfillment Entry Batch Processing Report

Select Fulfillment Management Advanced & Technical Ops (G4277730), Fulfillment Entry Batch Processing.

# Setting Processing Options for Fulfillment Entry Batch Processing (R4277704)

These processing options control override processing and versions for the Fulfillment Entry Batch Processing report.

## Process

### 1. Override Next Status

Indicate the next step in the order process. You must set up the user-defined code (40/AT) that you specify in the Order Activity Rules based on the order type and the line type that you are using.

The override status is another optional step in the fulfillment process. The combination of the beginning status and the override next status must be a valid last status/nest status combination in the Order Activity Rules table.

## Versions

### 1. Sales Order Entry (P4210)

Specify the version of Sales Order Entry program (P4210) that the system uses to govern the processing of sales order lines. If you leave this processing option blank, the system uses version ZJDE0001.

# 4 Scoring Order Detail Lines

## Understanding Scoring Order Detail Lines

With the JD Edwards EnterpriseOne Fulfillment Management system, you can set up the system to score order lines to determine the priority in which the system fulfills inventory. The system uses these factors to determine the score for order lines:

- Order type.
- Order line type.
- Sold to customer priority.
- Days to requested date.
- Custom business function.

The system can assign a score to order lines in two ways:

- At order entry, the system determines the score and attaches it to the order line.
- During a batch process, the system updates the score value of multiple order lines based upon the data selection.

The system provides two methods to determine the score on an order line:

- Advanced preference order score.
- Basic order score assignment.

**Note:** Scoring is an optional step in the fulfillment process. For example, you can fill inventory to order lines based on pick date or customer priority. An order line must be in the fulfillment process to be scored by the system.

The custom business functions provide you the flexibility to set up scoring logic without modifying any base code. The Sales Order Score Batch Processing report (R4277702) has an option to assign a weighted factor to the custom business function when you use advance preferences to calculate the score for order lines.

## Scoring During Sales Order Entry

To score order lines during order entry, you must ensure that the Fulfillment Management system is active and that the system processes the Fulfillment Entry preference at the time of order entry. You must also set the Calculate Order Score processing option to 1 and enter a version in the Fulfillment Management Scoring (R4277702) processing option in the Sales Order Entry program (P4210).

If you use advanced preferences to score the sales order detail lines, you must ensure the preferences are included in the preference schedule that is specified in the version of the Sales Order Score Batch Processing report (R4277702).

If you change any of the factors that determine the score of the sales order line, you must run the Sales Order Score Batch Processing report (R4277702).

## Custom Business Function

The custom business functions provide you the flexibility to set up additional scoring logic without modifying any base code in the system. You can use the template function (CustomScoringPriority) in the system to create a custom business function.

If you use advanced preferences to score sales order detail lines, use the processing option of the Sales Order Score Batch Processing report to enter the custom function name and the weighted factor for the score calculation.

If you use basic scoring, enter the custom function name in the Basic Score Setup program (P4277750).

## Setting Up Customer Priority

This section provides an overview of customer priority and discusses how to set up customer priority.

### Understanding Customer Priority

Because each customer has unique needs, you can define information to ensure that the system processes transactions according to the needs and specifications of each customer. The Customer Master program (P03013) enables you to control the priority in which the system processes sales orders for each customer.

For advanced preference scoring, the system uses the customer priority as a factor for calculating the score for sales order lines. The system multiplies the customer priority value by the weight value found in the processing options of the Fulfillment Batch Scoring report.

For the basic scoring method, the system uses the customer priority as a criteria for retrieving the score from the Basic Fulfillment Scoring Setup table (F4277750).

### Form Used to Set Up Customer Priority

Form Name	Form ID	Navigation	Usage
Billing Information	W03013E	<p>Sales Order Management Setup (G4241), Customer Billing Instructions</p> <p>Locate and Select a customer on the Work With Customer Master form.</p> <p>On the Customer Master Revision form, select Billing Information from the Form menu.</p>	Set the customer priority processing code.



Form Name	Form ID	Navigation	Usage
		On the Billing Information form, select the Billing Page 2 tab.	

## Setting Up Customer Priority

Access the Billing Information form.

### Priority Processing Code

The function of this field is two-fold:

- a. Enter a code that prompts the system to handle this customer's orders on a priority basis. Use this value to set up print pick slips so you can choose to print them on a priority basis. Also, you can sequence the backorder print report and automatic batch release program by this code to release those orders with the highest priority first.
- b. Enter a value that the system uses as a factor for calculating the score for a sales order line to be used in fulfillment processing. The system uses the numeric value in the Special Handling field of UDC H40/PR to determine the priority score for the customer. If the value in this field is not numeric, the system uses zero as a factor value.

## Setting Up Advanced Preference Scoring Details

This section provides an overview of advanced preference score and discusses how to:

- Set up preference detail values for Order Type Priority (42).
- Set up preference detail values for Line Type Priority (43).
- Set up preference detail values for Requested Date Age Priority (44).

## Understanding Advanced Preference Score

The advanced preference score method enables you to set up priority scores using advanced preference functionality. The system calculates the score for the order lines using the weight factors and determines a weighted average. The system calculates the score using the formula:

$$\text{Score} = [(\text{Order Type Priority} \times \text{Order Type Weighted Percent}) + (\text{Line Type Priority} \times \text{Line Type Weighted Percent}) + (\text{Requested Date Priority} \times \text{Requested Date Age Weighted Percent}) + (\text{Customer Priority} \times \text{Customer Weighted Percent}) + (\text{Custom Business Function Priority} \times \text{Custom Business Weighted Percent})]$$

### Scenario: Using Advanced Preferences to Score Order Lines

In this scenario, you are using advanced preferences to score the order lines during the fulfillment process. This chart illustrates the priority scores and weight percentages that you have set up for the factors that the system uses to calculate the score for an order line:

Order Type Scores		Line Type Scores		Requested Date Age Scores		Customer Scores		
Order Type	Priority Score	Line Type	Priority Score	Days Range	Priority Score	Customer	Priority Processing Code (H40/PR)	Priority Score
SO	3	S	6	0 – 3 Days	9	4242	3	4
S4	5	I	4	4 – 10 Days	7	4243	1	10
SZ	7	U	2	11 – 20 Days	5	4244	2	7

**Weighted Percentages**

- Order Type = 25%
- Line Type = 15%
- Requested Date Age = 30%
- Customer = 30%

In this scenario, the higher the priority score, the more important the priority for the order line.

**Note:** The weighted percentages must be equal to 100.

This table lists the details of the orders for your customers:

Customer	Details
4242	This customer has an order with these details:

Customer	Details
	<ul style="list-style-type: none"> <li>The order type = S4.</li> <li>The line type = S.</li> <li>The order is due in two days.</li> </ul>
4243	For this customer, the order details are the same as for customer 4242.
4244	This customer has an order with these details: <ul style="list-style-type: none"> <li>The order type = SO.</li> <li>The line type = I.</li> <li>The order is due in six days.</li> </ul>

The system calculates and compares the scores for each order line. Based on the information in this scenario, the system yields these results:

	4242		4243		4244	
	Calculation	Weighted Score	Calculation	Weighted Score	Calculation	Weighted Score
<b>Order Type Score</b>	5 x .25 =	<b>1.25</b>	5 x .25 =	<b>1.25</b>	3 x .25 =	<b>.75</b>
<b>Line Type Score</b>	6 x .15 =	<b>.90</b>	6 x .15 =	<b>.90</b>	4 x .15 =	<b>.60</b>
<b>Requested Date Age Score</b>	9 x .30 =	<b>2.70</b>	9 x .30 =	<b>2.70</b>	7 x .30 =	<b>2.10</b>
<b>Customer Score</b>	4 x .30 =	<b>1.20</b>	10 x .30 =	<b>3.00</b>	7 x .30 =	<b>2.10</b>
<b>TOTAL</b>		<b>6.05</b>		<b>7.85</b>		<b>5.55</b>

As a result of the calculations shown, the system first fulfills inventory to the order line for customer 4243, followed by customer 4242, and finally customer 4244.

## Form Used to Set Up Advanced Preference Scoring Details

Form Name	Form ID	Navigation	Usage
Preference Values Revisions	W4072D	Advanced Preferences (G40311), Advanced Preferences Detail Revisions  On the Work with Preference Detail form, locate and select a preference name.  On the Preference Detail Revisions form, select the record.  Select Pref Details from the Row menu.	Set up preference detail values.

## Setting Up Preference Detail Values for Order Type Priority (42)

Access the Preference Values Revisions form.

See *"Setting Up Adjustment Details"* in the *JD Edwards EnterpriseOne Applications Advanced Pricing Implementation Guide*.

### Preference Values Revisions

Tools

Preference Name: **ACKNOT** *Acknowledgement Notification*  
 Advanced Preference Type: **33** *Acknowledgement Notification*

Records 1 - 2

	Sequence	Business Unit	Transaction Acknowledged	Acknowledgement Code	Notification A/B
<input checked="" type="radio"/>	1.00	674	866		5734530
<input type="radio"/>					

«

**Sequence**

Enter a number that specifies the sequence of information.

**Or Type (order type)**

Enter a user-defined code (00/DT) that identifies the type of document that this preference processes.

**Order Type Priority**

Enter the priority value associated with the order type that the system uses as a factor for calculating a score for the sales order line. The system can calculate this score at sales order entry or through a batch process.

## Setting Up Preference Detail Values for Line Type Priority (43)

Access the Preference Values Revisions form.

See *"Setting Up Adjustment Details" in the JD Edwards EnterpriseOne Applications Advanced Pricing Implementation Guide*.

**Sequence**

Enter a number that specifies the sequence of information.

### **Ln Ty (line type)**

Enter a code that controls how the system processes lines on a transaction.

### **Line Type Priority**

Enter the priority value associated with the line type that the system uses as a factor for calculating a score for the sales order line. The system can calculate this score at sales order entry or through a batch process.

## Setting Up Preference Detail Values for Requested Date Age Priority (44)

Access the Preference Values Revisions form.

See "[Setting Up Adjustment Details](#)" in the *JD Edwards EnterpriseOne Applications Advanced Pricing Implementation Guide*.

### **Sequence**

Enter a number that specifies the sequence of information.

**Note:** You must sequence the information in *ascending* order to ensure that the system assigns the priority correctly.

### **Days until Requested Date**

Enter a value that represents the number of days until the requested date. The system calculates the days until requested date as the requested date minus today's date. The system applies this rule if this number is greater than or equal to the number of days and less than the next beginning number of days. The days until requested date calculation includes all calendar days. Enter a negative value to specify when the requested date is earlier. For example:

Days until requested date = -99999: Any order less than 99999 days past the requested date but more than 2 days past the requested date.

Days until requested date = -2: Any order one or two days past the requested date.

Days until requested date = 0: Any order with 0 to 4 days until the requested date.

Days until requested date = 5: Any order with 5 to 9 days until the requested date.

Days until requested date = 10: Any order with 10 to 29 days until the requested date.

Days until requested date = 30: Any order with 30 or more days until the requested date.

### **Requested Date Priority**

Enter the priority value associated with the days until requested date that the system uses as a factor for calculating a score for the sales order line. The system can calculate this score at sales order entry or through a batch process.

## Setting Up Basic Scoring Information

This section provides an overview of the basic score assignment method and discusses how to set up basic scoring information.

## Understanding Basic Score Assignment

The basic score assignment method enables you to use the Basic Score Setup program (P4277750) to predefine the score based upon the order type, requested date age, line type, customer priority, and custom business function. You can interactively enter, import, and export data. Sequence the data in all fields in ascending order to specify how the system retrieves the records.

This chart illustrates basic score assignment:

Order Type	Line Type	Customer Priority Value	Requested Date Age	Custom Function Priority	Priority Score
SO	S	10	5	0	6
SO	S	10	3	0	80
SO	S	10	1	0	95
SO	S	10	-99999	0	150
SO	S	5	5	0	50
SO	S	5	3	0	75
SO	S	5	1	0	90
SO	S	5	-99999	0	125
SO	S	0	5	0	45
SO	S	0	3	0	70
SO	S	0	1	0	85
SO	S	0	-99999	0	110
SR	S	10	-99999	0	120
SR	S	5	-99999	0	110
SR	S	0	-99999	0	90

Order Type = SO  
 Line Type = S  
 Customer Priority Value = 3  
 Requested Date Age = 4  
 Custom Function Priority = 0 (In this example, the custom function is not in use)



During the fulfillment process, the system retrieves the order score from the Basic Fulfillment Scoring Setup table (F4277750) and assigns the score to the order line. Based on the criteria in this example, the system assigns 70 as the score for the order line.

## Form Used to Set Up Basic Scoring Information

Form Name	Form ID	Navigation	Usage
Basic Scoring Setup	W4277750A	Fulfillment Setup (G4277740), Basic Scoring Setup	Set up basic scoring information.

## Setting Up Basic Scoring Information

Access the Basic Scoring Setup form. Use the top section of the form to filter records by order type, line type, customer priority range, requested date age range, and custom function priority range. You can also use a query to save the filter criteria.

### Basic Scoring Setup

Order Type       Line Type

**Customer Priority**      **Requested Date Age**      **Custom Function Priority**

From:       From:       From:   
 To:       To:       To:

Records 1 - 10 > >

<input type="checkbox"/>	<input checked="" type="checkbox"/>	Customer Priority From	Order Type	Requested Date Age From	Line Type	Custom Function Priority From	Order Score
<input type="checkbox"/>		10.000	54	999-	5	.000	101.000
<input type="checkbox"/>		10.000	54		5 5	.000	51.000
<input type="checkbox"/>		10.000	54		10 5	.000	11.000
<input type="checkbox"/>		10.000	54		40 5	.000	6.000
<< <input type="checkbox"/>		10.000	58	999-	5	.000	102.000
<input type="checkbox"/>		10.000	58		5 5	.000	52.000
<input type="checkbox"/>		10.000	58		10 5	.000	12.000
<input type="checkbox"/>		10.000	58		40 5	.000	7.000
<input type="checkbox"/>		10.000	50	999-	I	.000	104.000
<input type="checkbox"/>		10.000	50	999-	5	.000	100.000

#### Customer Priority From

Enter the customer priority to select the score during fulfillment processing. The system uses this value to select the basic score when it is less than or equal to the special handling code value for the Priority Processing UDC value (H40/PR) on the sales order line.

#### Requested Date Age From

Enter the number of days until the Requested Date (negative if Requested Date is earlier). The system uses this value to select the basic score during fulfillment processing when it is less than the difference between the requested date of the order line and today's date.

### **Order Type**

Enter the order type to select the score during fulfillment processing. The system uses this value to select the basic score when it equals the order type on the sales order line.

### **Line Type**

Enter the line type to select the score during fulfillment processing. The system uses this value to select the basic score when it equals the line type on the sales order line.

### **Custom Function Priority From**

Enter a custom function priority to select the score during fulfillment processing. The system uses this value to select the basic score when it is less than or equal to the value returned from the Custom Scoring Function specified in the processing options of the Sales Order Score Batch Processing report (R4277702).

### **Order Score**

Enter the score that the system assigns to an order line based on the specified factors. The system retrieves the score from the Basic Fulfillment Scoring Setup table (F4277750) and assigns the score to the order line.

## Running the Sales Order Score Batch Processing Report (R4277702)

This section discusses how to:

- Run the Sales Order Score Batch Processing report.
- Set processing options for Fulfillment Batch Scoring (R4277702).

## Running Sales Order Score Batch Scoring

Select Fulfillment Management Advanced & Technical Ops (G4277730), Sales Order Score Batch Processing.

## Setting Processing Options for Fulfillment Batch Scoring (R4277702)

### Process

#### **1. Scoring Method**

Specify the scoring method that the system uses to determine the order score for fulfillment processing. Values are:

Blank: Use the basic scoring method.

**1:** Use the advanced scoring method.

**Note:** The system calculates the score for advanced scoring based on the formula:  $\text{Score} = [(\text{Order Type Priority} \times \text{Order Type Weighted Percent}) + (\text{Line Type Priority} \times \text{Line Type Weighted Percent}) + (\text{Requested Date Age Priority} \times \text{Requested Date Weighted Percent}) + (\text{Customer Priority} \times \text{Customer Weighted Percent}) + (\text{Custom Business Function Priority} \times \text{Custom Business Weighted Percent})]$

## 2. Weight Factor for Order Type Priority Preference

Specify the percentage value that the system uses for the calculation weight of the Order Type Priority advanced preference.

When using the advanced scoring method, the system multiplies this percentage value by the value it retrieves from the Order Type Priority (42) advanced preference and includes the result when calculating the weighted score.

The system processes the value that you enter as a percentage. You must enter a value between 0 and 100, inclusive. The sum of the weighted processing options must equal 100.

## 3. Weight Factor for Line Type Priority Preference

Specify the percentage value that the system uses for the calculation weight of the Line Type Priority advanced preference.

When using the advanced scoring method, the system multiplies this percentage value by the value it retrieves from the Line Type Priority (43) advanced preference and includes the result when calculating the weighted score.

The system processes the value that you enter as a percentage. You must enter a value between 0 and 100, inclusive. The sum of the weighted processing options must equal 100.

## 4. Weight Factor for Customer Sold to Priority

Specify the percentage value that the system uses for the calculation weight of the Customer Sold to Priority.

When using the advanced scoring method, the system multiplies this percentage value by the numeric special handling code value it retrieves from the Sold to Customer priority (UDC H40|PR) and the result is included in the calculation of the weighted score.

The system processes the value that you enter as a percentage. You must enter a value between 0 and 100, inclusive. The sum of the weighted processing options must equal 100.

## 5. Weight Factor for Requested Date Priority Preference

Specify the percentage value that the system uses for the calculation weight of the Requested Date Priority advanced preference.

When using the advanced scoring method, the system multiplies this percentage value by the value it retrieves from the Requested Date Priority (44) advanced preference and includes the result when calculating the weighted score.

The system processes the value that you enter as a percentage. You must enter a value between 0 and 100, inclusive. Also, the sum of the weighted processing options must equal 100.

## 6. Weight Factor for Custom Priority

Specify the percentage value that the system uses for the calculation weight of the custom business function.

When using the advanced scoring method, the system multiplies this percentage value by the numeric value it retrieves from the Custom Priority Calculation Function, defined in the next processing option, and includes the result in the calculation of the weighted score.

The system processes the value that you enter as a percentage. You must enter a value between 0 and 100, inclusive. The sum of the weighted processing options must equal 100.

## 7. Custom Priority Calculation Function

Specify the business function name that the system uses for calculation of a custom priority used to determine the score of the line. The custom priority calculation function uses the predefined data structure D4277701A and returns the numeric priority through the order score parameter.

For the basic scoring method, the system uses the custom priority as a criteria for retrieving the score from the Basic Fulfillment Scoring Setup table. If you leave this processing option blank, the system retrieves zero as the score value for the custom function.

For the advanced scoring method, the system multiplies the priority value that it retrieves from the custom function by the weight factor for the custom priority and includes the result in the summation of the score. If you leave this processing option blank, the system retrieves zero as the value to include in the summation of the score.

### **8. Override Advanced Preference Schedule**

Specify a preference schedule for the system to use instead of the default preference schedule defined in the system constants. This schedule controls the preference processing for the Order Type Priority (42), Line Type Priority (43), and Requested Date Priority (44) advanced preferences, which are used in the advanced scoring method calculation.

**Note:** You use the Advanced Preferences Schedule Revisions program (P4070) on the Advanced Preferences menu (G40311) to modify preference schedules.

### **9. Set warning when basic score is not found**

When using the basic scoring method, specify whether the system sets a warning when the system does not find a basic score. The system uses zero as the default value for the score on the order line.

If a high score indicates a more important priority, you do not have to set up basic scoring data for the lowest priority order lines.

If a low score indicates a more important priority, zero could be a valid score for the order detail lines. Use this processing option for the system to issue a warning when a score for the order line cannot be found. This setting prevents you from attaching the most important priority score to lines inadvertently.

Values are:

Blank: Do not set warning.

**1:** Set warning.



# 5 Setting Up and Processing Service Level Rules

## Setting Up Service Level Rules

This section provides an overview of service level rules and discusses how to set up service level rules.

### Understanding Service Level Rules

A service level agreement (SLA) is a negotiated agreement between two parties where one is the customer and the other is the service provider. This agreement can be a legally binding formal or informal contract. The SLA records a common understanding about services, priorities, and responsibilities. The SLA may specify the levels of availability, serviceability, or performance that the service provider must provide. This level of service can also be specified as target or minimum; allowing customers to be informed about what to expect. In some contracts, penalties may be agreed upon based on noncompliance by either party.

A service level rule defines the requirements for fulfilling sales orders for your customers. You use the Service Level Rule Maintenance program (P4277760) to define service level rules for the JD Edwards EnterpriseOne Fulfillment Management system. The system searches for service level rules based upon customer, customer group, item, item group, branch plant, release number, effective date, and expiration date. The system resolves the service level rules and updates the Service Level Rule table (F4277701) and the Service Level Rule Detail table (F4277711) during these processes:

- Entering a sales order using a version of Sales Order Entry (P4210) that is set up to resolve service level rules.
- Running the Service Level Rule Processor report in batch.
- Changing the branch plant from the Fulfillment Workbench program (P4277701).
- Running the Release from Fulfillment report (R4277703). This is for split lines only.

Within JD Edwards EnterpriseOne Fulfillment, service level rules can include:

- Line fill percent rule.
- Order fill percent rule.
- Release rule.
- Cancellation rule.
- Partial commit rule.
- Line custom function rule.
- Order custom function rule.

**Note:** Service level rules are optional in the fulfillment management process.

## Line Fill Percent Rules

You can use the line fill percent rule to specify the minimum fill percentage for a sales order line. Each sales order line can have its own line fill percent rule. The fill percentage is cumulative across all releases of a line including multiple splits for a line.

The system determines the line fill percent by dividing the line quantity filled by the line quantity ordered. If the result does not meet or exceed the minimum fill percentage, the system does not release the sales order line from fulfillment. The system can perform this evaluation when you:

- Use the Fulfillment Workbench program (P4277701).
- Run the Auto Fulfillment Processing report (R4277701).
- Revise a sales order that has fulfillment quantity.

**Note:** When the rule includes multiple release numbers, the minimum required fill percent is cumulative for the line based on the requested order quantity, not the split order quantity.

This table is an example of sales order lines with line fill percent requirements:

Line	Item	Line Fill Percent Rule Requirement	Quantity Fulfilled	Quantity Ordered	Quantity Percent Filled	Line Fill Percent Rule Met
1	A	85%	9	10	90%	Y
2	B	90%	4	5	80%	N
3	C	80%	7	10	70%	N
4	D	90%	7	7	100%	Y
5	E	85%	5	5	100%	Y

In this example, lines 1, 4, and 5 meet or exceed their respective line fill percent rule requirements. The system releases these lines from fulfillment. However, lines 2 and 3 do not meet their respective line fill percent rule requirements. The system evaluates lines 2 and 3 as sales order lines that fail to meet their respective line fill percent rule requirements. Thus, the system does not release these lines from fulfillment.

The system ensures the minimum percent to fill is met or exceeded when you run the Release from Fulfillment report (R4277703). If the line has not met the requirements, the system does not release the line from fulfillment.

## Order Fill Percent Rules

At the order level, the system evaluates whether the number of lines filled on an order meet the minimum fill percent for the initial release of the order.

The system determines the order fill percent by dividing the number of lines that meet their respective line fill requirements by the total number of lines on the order that are in fulfillment. When calculating the order fill percent, the



system uses only lines entered into the fulfillment process that have an associated order service level rule. Therefore, the process is twofold:

1. The system determines whether the quantity filled on all fulfillment lines of the order meet or exceed their respective line fill percent rule.
2. The system performs the calculation above to determine the order fill percent.

This table is an example of a sales order that meets order fill percent rule requirements:

**ORDER FILL PERCENT RULE = 80%**

Line	Item	Line Fill Percent Requirement	Quantity Fulfilled	Quantity Ordered	Quantity Percent Filled	Line Fill Percent Rule Met
1	A	85%	9	10	90%	Y
2	B	90%	9	10	90%	Y
3	C	80%	7	10	70%	N
4	D	90%	7	7	100%	Y
5	E	85%	5	5	100%	Y

In this example, line 3 does not meet the line fill percent requirements. However, because Lines 1, 2, 4, and 5 meet or exceed their respective line fill percent requirements, the system evaluates the sales order as meeting the order fill percent rule requirements ( $4/5 = 80$  percent). The system releases four lines from fulfillment when you run the Release from Fulfillment report.

This table illustrates an example of a sale order that *does not* meet order fill percent rule requirements:

**ORDER FILL PERCENT RULE = 80%**

Line	Item	Line Fill Percent Rule Requirement	Quantity Fulfilled	Quantity Ordered	Quantity Percent Filled	Line Fill Percent Rule Met
1	A	85%	9	10	90%	Y
2	B	90%	4	5	80%	N
3	C	80%	7	10	70%	N
4	D	90%	7	7	100%	Y
5	E	85%	5	5	100%	Y

In this example, lines 2 and 3 do not meet their respective line fill percent requirements. The system evaluates the sales order as failing to meet the order fill percent rule requirements ( $3/5 = 60$  percent). The system does not release any lines from fulfillment.

When you run the Auto Fulfillment Processing report (R4277701), the system processes all sales order lines in accordance with the data selection that you set up. During the process, the system evaluates fulfillment for each line on the sales order before determining whether the order fill percent meets the established requirements.

When using the Fulfillment Workbench program (P4277701) or the Sales Order Entry program (P4210) to revise sales orders, the first line that you select and modify alerts the system to evaluate the order fill percent. The system evaluates all sales order lines to determine whether the order fill percent meets the established requirements. The system records changes to the order fill percent in the Order Header Percent field that applies to all lines on the order that have an order level rule attached.

**Note:** The last change to the order fill percent supersedes any previous changes.

The system edits against the order level rules during sales order entry and during Auto Fulfillment processing. This action ensures that the order level fill percent is the same for all lines on the order that have an order level rule. If order lines have different order fill percents, the system:

1. Uses the highest fill percent.
2. Records the fill percent in the Order Header Percent field.
3. Records an appropriate reason code.

The system only evaluates the order fill percents for the first release of an order from fulfillment. On subsequent releases, the system evaluates the open lines using line level rules.

When processing kits using an order fill percent rule, the system includes only the kit parent line in the calculation. The system does not use the kit component lines for calculations.

## Release Rules

Release rules enable you to manage the number of releases for a line. You can use the Service Level Rules Maintenance program (P4277760) to specify the number of fulfillment releases for a line. You can define rules that apply to all releases of lines or define rules for each specific release number. For example, you may want to limit the number of releases for a customer to three. You could set up the three releases with this criteria:

- Release 1 requires 80 percent fulfillment.
- Release 2 requires 95 percent fulfillment.
- Release 3 requires 100 percent fulfillment.

On the final release number, the minimum fill percent must equal 100 percent to ensure the full quantity is processed. The system does not release the line from fulfillment if the fill percent is not met. You can also use the Cancel Rule for the last release number to ensure the remaining open balance on the line is canceled. If you do not require a 100 percent fill or cancel the open balance, the system does not assign a minimum fill percent requirement for the split lines. The line can create additional lines and could have an additional number of splits because the system does not enforce any service level rule information.

If the system does not find an associated service level rule for a specific release number, it searches for the default release number rule. If the system does not find a default release number rule, it does not apply any rule to the order line.

## Cancellation Rules

Cancellation rules enable you to specify at what fill percent the open balance of the line can be canceled. You can use the Service Level Rules Maintenance program to specify whether the system cancels the balance of a line. For example:

1. Customer A requires a 95 percent line fill percent. When this line fill percent is met, the system leaves the remaining 5 percent open and splits it onto a new line.
2. Customer B requires a 98 percent line fill percent. When this line fill percent rule is met, the system enables cancellation of the remaining 2 percent. The cancellation occurs when the system runs the Release from Fulfillment report (R4277703).

You could use the release number with the cancel rule to prevent further releases. For example:

- Release 1 requires 80 percent filled.
- Release 2 requires 95 percent filled.
- Release 3 requires 98 percent filled and cancels the 2 percent open balance.

## Partial Commit Rules

Partial commit rules enable you to specify whether the system soft commits inventory for partial order quantities to sales order lines. You use the Service Level Rules Maintenance program to specify whether the system reserves quantity on a line until more inventory becomes available to meet the line and order fill percent requirements.

If you do not set the flag to perform partial commitments, the inventory is available for other sales orders. When using order fill percent rules, the system must process all lines on the sales order with an associated order fill percent rule and determine whether the fulfilled quantity meets the order fill percent requirements. If the order does not meet the minimum order fill percent requirements, the system does not soft commit inventory to any of the lines on the order. For example:

- Order quantity = 100
- Line fill percent = 90
- Available Quantity = 50

- Partial commit = No

In this example, the 50 units available to be committed to the line remain available and the sales order line does not have any quantity soft committed. The system does not assign inventory to the line until at least 90 items are available to meet the 90 percent fill level.

**Note:** The system evaluates the partial commit rule during the auto fulfillment process only.

## Line Custom Function Rules

You can use the line custom function rule to specify the custom function that the system uses to determine whether requirements are met for a sales order line. Each sales order line can have its own line custom function rule. If the custom function determines that the order line has not met the requirements, the system does not release the sales order line from fulfillment. The system can perform this evaluation when you:

- Use the Fulfillment Workbench program (P4277701).
- Run the Auto Fulfillment Processing report (R4277701).
- Revise a sales order that has fulfillment quantity.

The system ensures that the requirements are met when you run the Release from Fulfillment report (R4277703). If the line does not meet the requirements, the system does not release the line from fulfillment.

## Order Custom Function Rules

At the order level, the system launches the custom function specified at the order header level to determine whether the order lines with an order level custom function rule has met the requirements. If multiple order service level rules with different order custom functions are resolved for the same order, the system uses the first order custom function to determine whether the order service level rule requirements are met. The system returns the custom function requirement determination to all lines on the order with an order level rule type.

The system ensures that the requirements are met when you run the Release from Fulfillment report (R4277703). If the order does not meet the requirements, the system does not release the order from fulfillment.

## Form Used to Set Up Service Level Rules

Form Name	Form ID	Navigation	Usage
Service Level Rule Maintenance	W4277760A	Fulfillment Setup (G4277740), Service Level Rules Setup	Set up service level rules.

## Setting Up Service Level Rules

Access the Service Level Rule Maintenance form.

You can use the header section of the form to filter the records that are displayed in the grid.

**Service Level Rule Maintenance**

**Effective Date**  
 From:   
 Through:

**Expiration Date**  
 From:   
 Through:

Records 1 - 3

	Address Number	Customer Group	Item Number	Item Group	Business Unit	Release Number	Effective Date	Expired Date	Rule Type
10	55159					1	01/01/2010	12/31/2040	02
20	55167					1	01/01/2010	12/31/2040	01

**Sequence Number**

Enter a sequence number that the system uses to process records in a user-defined order. The system searches for rules based upon the sequence. You should sequence rules from those that are specific to those that are general.

**Address Number**

Enter a number that identifies an entry in the JD Edwards EnterpriseOne Address Book system, such as customer.

**Customer Group**

Enter a user-defined code (UDC) (40/PC) that identifies a customer group. You can group customers with similar characteristics to process records.

#### **Item Number**

Enter a number that the system assigns to an item. It can be in short, long, or third item number format.

#### **Item Group**

Enter a UDC (40/PI) that identifies an inventory price group for an item. You can group items with similar characteristics to process records.

#### **Release Number**

Enter a number that represents the release number for sales order lines. This number represents the number of times that the system has released a sales order line from the Fulfillment Management system. The initial (original) line on the order before any splits is the first release or release number 1.

When the Release from Fulfillment report (R4277703) splits a line and does not cancel the remaining quantity, the system increments the release number for the new line by a single count. For example, the first split is release 2, the second is release 3, and so on.

You can specify different rule requirements for each release number.

#### **Rule Type**

Specify the service level rule type that you have set in the Fulfillment Management system. Values are:

**01:** Order service level rule.

**02:** Line service level rule.

The system can only set an order service level rule type for the first release number. All subsequent or default releases are set as a line service level rule type.

#### **Order Minimum Fill Percent**

Enter the minimum percentage of sales order lines that must meet their respective line requirements to release the order from fulfillment.

If the system retrieves a custom function and an order minimum fill percent rule to resolve the same order, the system uses the custom function to determine whether the order service level rule was met.

#### **Line Minimum Fill Percent**

Enter the minimum percentage of the order line quantity necessary to release the line from fulfillment.

#### **Cancel YN (cancel yes or no)**

Select the check box if you want the system to cancel unfulfilled quantity for a sales order line when the system runs the Release from Fulfillment report (R4277703).

#### **Partial Commit**

Select the check box if you want the system to partially fulfill an order line that does not meet the service level rule requirements when using the Auto Fulfillment Processing report (R4277701).

#### **Custom Function**

Enter the name of the custom function that evaluates order or line rule types.

When creating rules, the system enables and disables fields based on the fields that you populate. For example, if you enter an address book number, then the system disables the customer group field.

The system does not allow you to enter order and line fill percents, and a custom business function. When you use custom business functions, the line and order fill requirements are determined within the function.

## Processing Service Level Rules at Sales Order Entry

This section provides an overview of processing service level rules at sales order entry and discusses:

- Service level rule resolution.
- Service level rule override processing.
- Dynamic overrides of service level header information.
- Requested order quantity update.
- Service level rule processing.
- Service Level Rule Evaluation Required flag.
- Updating service level rule header and detail tables.

## Understanding Processing Service Level Rules at Sales Order Entry

This diagram illustrates the service level rule processing at sales order entry:



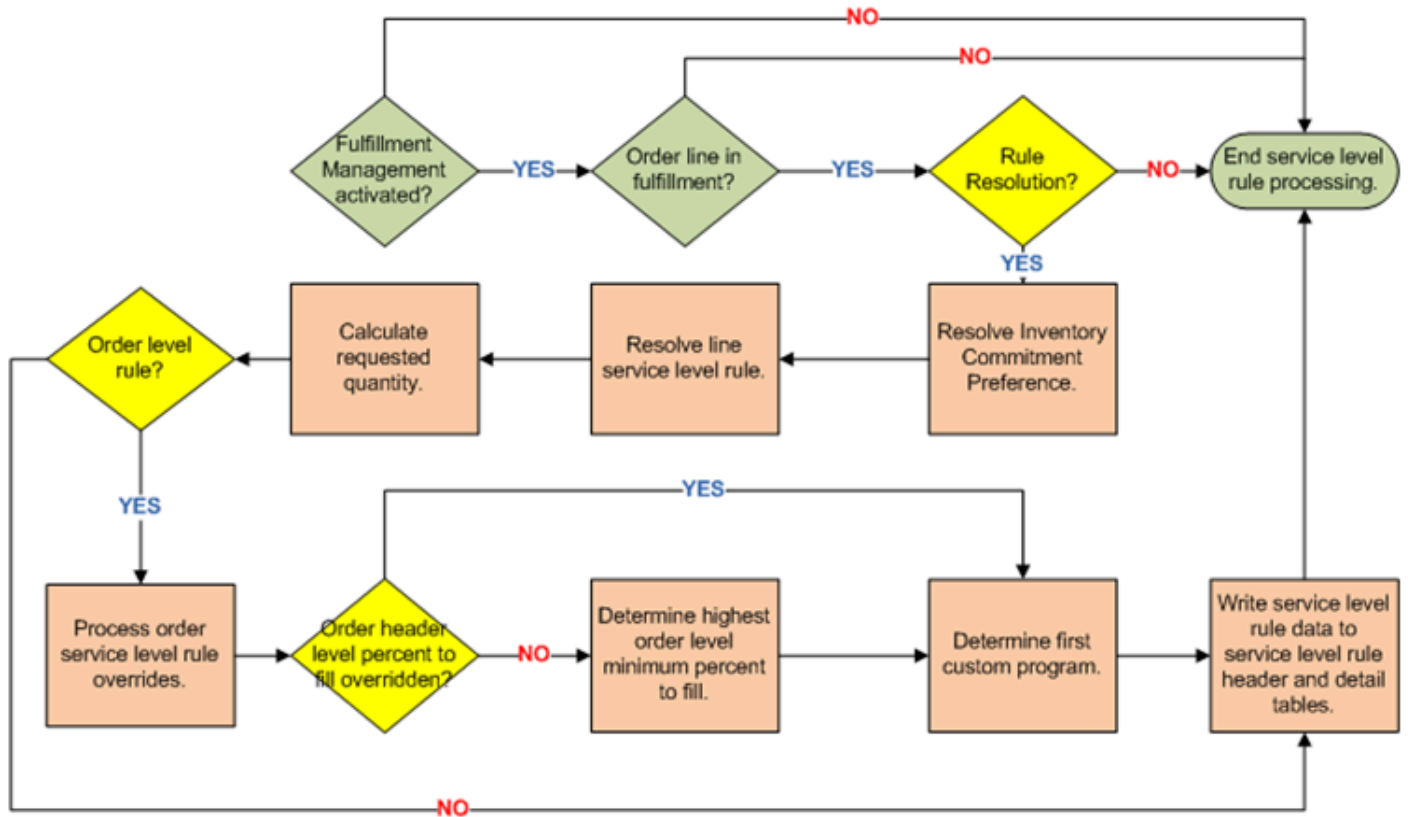

The system constructs service level rules for processed sales order header and lines whenever one of these processes occur:

- Creation of a new sales order or sales order line.
- Changing the branch/plant for a sales order line from the Fulfillment Workbench.
- Changing the branch plant at sales order entry.
- Resolving service level rules for sales orders that are entered into the fulfillment process from running the Service Level Rules Update report (R4277705).
- Splitting shippable sales order lines during release from fulfillment processing.
- Running the Fulfillment Entry Batch Processing report (R4277704).

## Service Level Rule Resolution

Service level rule resolution is driven by customer sold to, customer sold to group, item, item group, branch/plant, release number, and the requested date falling between the effective and expiration dates. These driver fields provide flexibility for you to set up service level rules based on customer or business requirements. The system resolves a service level rule when the value in the service level rule is blank or it matches the driver field that the system validated on the sales order line.

The release number driver field enables you to set up different rules by release such that the rules may get stricter with each release or limit the number of releases.

The system resolves the service level rule and returns a combination of these values:

Value	Comments
Rule type.	The rule type is required because this value determines whether the service level rule is at the line level or order level.
Line level percent to fill.	The system retrieves either the line level percent to fill or the custom program to determine whether the service level rule requirements for the order lines have been met.
Order level percent to fill.	The system retrieves both the line level and order percents to fill or the custom program to determine whether the service level rule requirements for the order have been met.
Custom program.	The system retrieves the custom program to determine whether the service level rule requirements for the order have been met.
Cancel flag.	The system sets the cancel flag to <b>Yes</b> or <b>No</b> depending on whether you want to cancel quantities not fulfilled when the service level rule requirements are met.
Partial commit flag.	The system sets the partial commit flag to <b>Yes</b> or <b>No</b> depending on whether you want to commit inventory on partially fulfilled lines that do not meet the service level rule requirements.

In each instance where the system resolves the service level rule, the system populates the return values into the Service Level Rule Header table (F4277701) and the Service Level Rule Detail table (F4277711).

During sales order entry, the system resolves the service level rules after resolving the inventory commitment preference. The branch/plant of the inventory commitment preference drives the resolution of the service level rules. When you change the branch/plant the resolution of service level rules is not affected by the resolution of any other preferences.

## Service Level Rule Override Processing

You can override the system populated rules if necessary. After the system resolves rules for an order line, you can access the rules and make revisions. You can access the Override/Inquiry form using either of the Sales Order Entry programs (P4210 and P42101).

If you override the line level percent to fill, the system uses the override value to evaluate whether the rule requirements are met. The system replaces the line level percent to fill that was resolved using the service level rule information. If you override the order header level percent to fill, the system assigns the order level fill percent override to the header and the system does not replace the individual order level fill percents resolved from the service level rule information. However, the system uses the Order Header Level Fill Percent to determine whether the order fill percent has been met for all order lines with an order level rule type.

You cannot add new service level rule information during sales order entry. Also, if a line enters into fulfillment processing and the system does not assign a rule (because the line is ineligible), you cannot create service level rule information for the line.

## Dynamic Overrides of Service Level Header Information

The system evaluates the existing lines on an order to determine the order header level percent to fill and the order level custom program.

The system also populates the override Reason Code field with the value **DYN** (dynamically assigned). This indicates that the system determined the minimum fill percentage values found in the order header.

To determine the order header level percent to fill, the system compares the order level fill percents for all the lines on the order with an order level rule and assigns the highest percent to the order header. The system stores this value in the F4277701 table. The system makes this determination only if you do not interactively override the order header level fill percent. The system stores the lowest line number associated with the selected fill percent in F4277701 table. The system uses this line number if you cancel a line and the system has to determine a new order header level fill percent.

To determine the order level custom program, the system sorts the order lines by line number and assigns the custom program from the lowest line number with an order level rule type to the order header. The system stores this line number in the Service Level Rule Header table and uses it when you cancel a line and the system has to determine a new order level custom program.

## Requested Order Quantity Update

When you create a sales order line, the system updates the quantity ordered to the requested quantity in the Service Level Rule Detail table (F4277711).

The system uses the requested quantity to determine the total fill rate when lines have been split.

When you change the quantity ordered on a sales order line, the system updates the difference between the existing quantity ordered and the new quantity ordered and all related lines. For example, if you change the quantity ordered on a line that has been partially released, the system updates the requested quantity on both the line currently being processed and the line or lines that were previously released.

When the system splits a sales order line, the system copies the existing requested quantity to the split line.

## Service Level Rule Processing

When you revise the quantity ordered on a sales order line with a fulfilled quantity, the system evaluates the service level rule data and determines whether service level requirements have been met. If the requirements have been met, the system sets the Line/Order Rule Evaluation Required flag.

## Service Level Rule Evaluation Required Flag

The Service Level Rule (SLR) Evaluation Required flag indicates the impact that changes to sales order lines have in determining whether the system reevaluates the sales order lines or order meet service level rule requirements. When using order and line fill percentages, changing the order quantity or overriding the line or order percents can set the flag. Changing the branch plant on the sales order detail lines always sets the flag. The values are:

- **0:** There has been no material change that impacts the state of the service level rule requirements.
- **1:** The order line has experienced a material change which impacts whether the service level rule has been met

When the SLR Evaluation Required flag equals **1**, this indicates that the criteria for the release of a line as determined by the Service Level rule met status has changed. Before the system can release the order line, you must accept the change using one of four methods:

- You can deselect the evaluation required flag for the line or order from the edit form of the Fulfillment Workbench program.
- You can use the Fulfillment Workbench to change the fulfilled quantity, branch plant, or promised delivery date on the order line.
- You can run the Auto Fulfillment report (R4277701) to reevaluate the line; thereby accepting any change.
- The can run the Service Level Rules Update report (R4277705) to reevaluate the service level rules for the order line or order.

The system checks the SLR Evaluation Required flag value whenever a change occurs at sale order entry. When the system uses a fill percentage rule, changes to order quantity or an override change to the line or order fill percent can effect a possible change in the met flags. If you change the branch plant from sales order entry, the system checks the SLR Evaluation Required flag.

### Service Level Rules Inquiry/Overrides (P4277711)

The system displays the SLR Evaluation Required flag at the order header level. When the *order* fill percent is overridden and the result is a change to the Order Level Met flag, the system sets the SLR Evaluation Required flag to **1** on the header and for all sales order lines with an associated order level rule type.

When the *line* fill percent is overridden and the result is a change to the Line Level Met flag, the system sets the SLR Evaluation Required flag to **1**. If you cancel out of the Service Level Rules Inquiry/Override form after making changes, then the system restores the existing values for the override percent, reason codes at the order and line level, and the SLR Evaluation Required flag.

## Fulfillment Workbench (P4277701)

On the Fulfillment Workbench — Search form grid, the SLR Evaluation Required flag is visible for query filter purposes. On the Fulfillment Workbench — Edit form the SLR Evaluation Required flag is indicated by a check box in the grid. When the value of the SLR Evaluation Required flag equals **1**, the system displays the check box as selected. If the value is **0**, the system deselects the check box.

## Auto Fulfillment Processing (R4277701)

When you run the Auto Fulfillment Processing report to check for lines where the SLR Evaluation Required flag is set to **1**, the Service Level Rule Engine reevaluates the data to determine whether the order or line level rules are met.

## Service Level Rules Engine

When the Service Level Rules Engine evaluates a line from P4277701 or R4277701, and the SLR Evaluation Required flag equals **1**, the system sets the SLR Evaluation Required flag to **0**.

## Release from Fulfillment (R4277703)

When you run the Release from Fulfillment report, the system does not release any line with the SLR Evaluation Required flag set to **1**. The system marks these lines in error and creates a PDF error report in the work center. If you activate email functionality, the system includes these lines in the email notification for lines that the system did not release.

## Service Level Rules Update (R4277705)

When you run the Service Level Rules Update report to resolve a rule, the system does not set the SLR Evaluation Required flag.

# Updating Service Level Rule Header and Detail Tables

When the system resolves a service level rule, the system updates the following information to the Service Level Rule Header and Detail tables:

Service Level Rule Header Table (F4277701)	Service Level Rule Detail Table (F4277711)
Order Minimum Fill Percentage	Service Level Rule Type
Service Level Override Reason Code	Line Minimum Fill Percentage
Order Minimum Fill Line Number	Service Level Override Reason Code
Service Level Custom Function	Line Service Level Met
Service Level Custom Function Line Number	Order Minimum Fill Percentage
Order Released	Order Service Level Met

Service Level Rule Header Table (F4277701)	Service Level Rule Detail Table (F4277711)
Order Service Level Met	Service Level Custom Function
SLR Evaluation Required Flag	Service Level Release Number
	Service Level Cancel Y/N
	Service Level Cancel Override
	Service Level Partial Commit
	Requested Quantity
	Service Level Original Line Number
	SLR Evaluation Required Flag

When you change the quantity ordered, quantity fulfilled, or override the rule information for a sales order or line, the system updates the following information in the Service Level Rule Header and Detail tables:

Service Level Rule Header Table (F4277701)	Service Level Rule Detail Table (F4277711)
Order Minimum Fill Percentage	Line Minimum Fill Percentage
Service Level Override Reason Code	Service Level Override Reason Code
Order Minimum Fill Line Number	Requested Quantity
Service Level Custom Function	Line Service Level Met
Service Level Custom Function Line Number	Order Service Level Met
SLR Evaluation Required Flag	SLR Evaluation Required Flag

# Running Service Level Rules Update (R4277705)

This section provides an overview of service level rules processing and discusses how to:

- Run the Service Level Rules Update report.
- Set processing options for Service Level Rules Update (R4277705).

You run the Service Level Rules Update report to assign service level rules to sales order lines in the Fulfillment Management system independent of the sales order entry process. This diagram illustrates the process that occurs when you launch the Batch Service Level Rule Processing report:

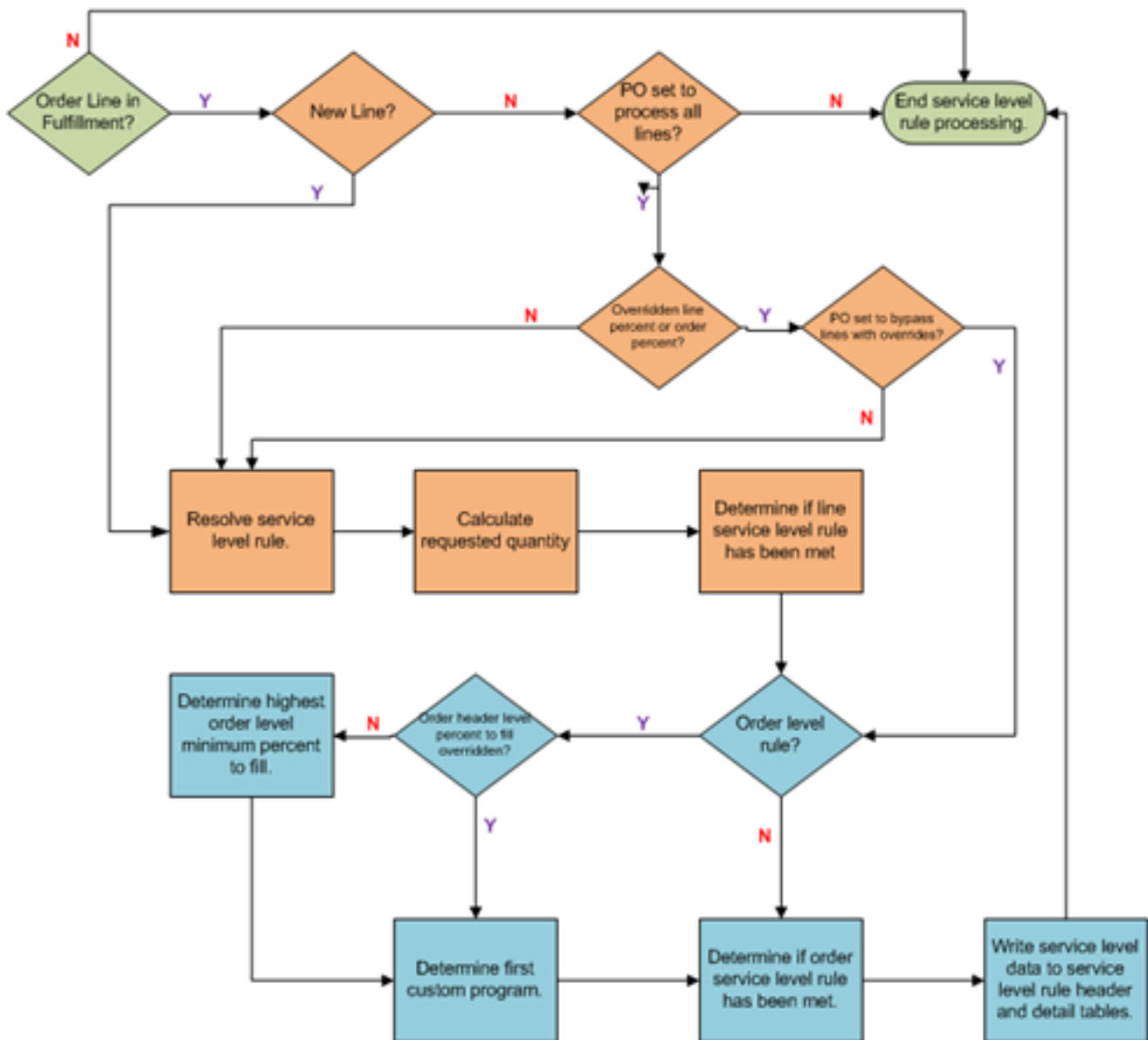

# Running the Batch Service Level Rule Processing Report

Select Fulfillment Management Advanced and Technical Ops (G4277730), Service Level Batch Processing.

## Setting Processing Options for Service Level Rules Update (R4277705)

These processing options control service level rule resolution processing.

### Process

#### **1. Bypass service level rule resolution for sales order lines with existing service level rules.**

Specify whether the system resolves service level rules for sales order lines with existing service level rules. This option governs both the processing within this program and the resolution of a new service level rule when you change the branch plant during either sales order entry processing or processing from the Fulfillment Workbench. Values are:

Blank: Resolve service level rules for sales order lines with existing service level rules. The system removes the existing rule and resolves a new rule based on the information in the service level rule table.

**1:** Bypass service level rule resolution for sales order lines with existing service level rules. The system retains the rules on the sales order line.

#### **2. Bypass service level rule resolution for sales order lines with overridden order or line minimum percents to fill, or an overridden cancel rule flag.**

Specify whether the system resolves service level rules for sales order lines with overridden values. Override values can include line level minimum percents to fill or an overridden cancel rule. When the system resolves service level rules, it replaces all overridden values with values from the resolved service level rule. This option governs both the processing within this program and the resolution of a new service level rule when you change the branch plant during either sales order entry processing or processing from the Fulfillment Workbench. Values are:

Blank: Resolve service level rules for sales order lines with override values.

**1:** Bypass service level rule resolution for sales order lines with overrides values.

#### **3. Clear overridden order minimum percent to fill when service level rule is resolved.**

Specify whether the system, while resolving service level rules, clears the overridden minimum percent to fill value on the order header. The system does not clear the values on the detail lines. Values are:

Blank: Maintain the overridden order minimum fill percent to fill during service level rule resolution.

**1:** Clear the overridden order minimum fill percent during service level rule resolution. The system removes the existing value and resolves the new value using the service level rule information on the order detail lines.

#### **4. Suppress report output.**

Specify whether the system suppresses report output.

Blank: Do not suppress report output.

**1:** Suppress report output.



## Overriding Service Level Rules

This section provides an overview and discusses how to override service level rules.

### Understanding Overriding Service Level Rules

The Service Level Rules Inquiry/Override program (P4277711) enables you to override the system-resolved service level rules. You can reset the order and line level fill percent values that are associated with qualified order lines. This application is available from the Form and Row menus of the Sales Order Entry programs (P4210) and (P42101).

You cannot dynamically add rules to lines that do not have a rule. You can only revise existing rules.

The Service Level Rules Inquiry/Override program requires that you enter a reason code for any overrides. If you override the fill percent on a line, the system reevaluates the line in relation to the overridden order fill rates and resets the Line and Order Rule Evaluation Required flag values as necessary. Some examples are:

1. When you change the line percent and there is a fulfilled quantity for the line, the system:
  - a. Evaluates whether the line fill percent has been met.
  - b. Updates the Line Rule Evaluation Required flag if the requirement met status has changed.
2. When you change the order fill percent, the system:
  - a. Updates the override fill percent.
  - b. Evaluates the entire order to determine whether the order requirement met status has changed and if so, updates the Order Header Rule Evaluation Required flag.
  - c. Updates the order rule evaluation required flag for all lines with an order level rule.
3. When you change the line percent for a line with an order level rule, the system:
  - a. Evaluates whether the line fill percent has been met.
  - b. Updates the Line Rule Evaluation Required flag if the requirement met status has changed.
  - c. Evaluates the entire order to determine whether the order requirement met status has changed and if so, updates the Order Header Rule Evaluation Required flag is set.
  - d. Updates the Order Rule Evaluation Required flag for all lines with an order level rule.

You can override order level percents at the order header only. The order header fill percent value applies to all lines on the sales order that have an order level rule. The system uses these lines to evaluate whether the order fulfill quantities meet the order level percent to fill requirements.

If a sales order line has a line type rule, the order level values do not override the line level values.

Order lines associated with a custom program rule are not eligible for any service level rule overrides.

If an order has different custom functions on the order lines then the system uses the first custom function on the order. For example, if you had an order with this order detail:

Line Number	Custom Function	Order Rule Type
1	A	N
2	B	Y

Line Number	Custom Function	Order Rule Type
3	C	Y
4	D	N
5	E	Y

In this example, the first function where the order flag is set that the system finds is line 2 with custom function B. The system then applies custom function B to lines 2, 3, and 5. The system evaluates lines 1 and 4 as line level rule types.

## Form Used to Override Service Level Rules

Form Name	Form ID	Navigation	Usage
Service Level Rules Inquiry/Override	W4277711A	<p>Sales Order Processing (G4211), Sales Order Detail.</p> <p>Locate a sales order and click Select.</p> <p>On the Sales Order Detail Revisions form, select a detail record.</p> <p>Select Service Level Rules from the Row menu.</p>	Review and override service level rules.

## Overriding Service Level Rules

Access the Service Level Rules Inquiry/Override form.

### Minimum Fill Percentage

Enter the minimum fill percent of sales order lines that must meet the line requirement for an order service level rule to be met.

If the system resolves rules with custom function with order minimum fill percentage for the same order, the system uses the first custom function on the order.

If the system resolves multiple order level rules with different fill percentages and no custom functions for the same order, the system uses the highest order minimum fill percentage.

The system dynamically populates the value into this field and uses the value to determine if the order service level rule has been met.

### Override Reason Code

Enter a UDC value (42W/RC) to indicate the reason that you are overriding the minimum fill percentage at either the order or line level.

If the system dynamically populates the Minimum Fill Percentage field, the override reason code is **DYN** (Dynamically Assigned).

If the system populates the Minimum Fill Percentage field at the order or line level by copying a sales order, the override reason code is **CPY** (Copy).

#### **Service Level Rule Evaluation Required**

The system sets this flag to indicate a sales order was changed and requires service level reevaluation. This indicates that the line or order service level rule requirements met status may change.

#### **Order Released**

The system sets this flag to indicate that the order has been released. If an order has been released, the system processes the remaining open lines as line service level rules.

#### **Order Service Level Met**

The system sets this flag to indicate that the order service level requirements have been met for the sales order.

#### **Cancel Y/N**

The system specifies whether the unfulfilled quantity for a sales order line is canceled when a sales order line with a service level rule is released from the Fulfillment Management system using the Release from Fulfillment report (R4277703). Values are:

**0:** Do not cancel unfulfilled quantity.

**1:** Cancel unfulfilled quantity.



# 6 Auto Fulfillment Processing

## Understanding Auto Fulfillment Processing

The sales order process, without fulfillment, does not provide a way to match high priority sales order lines with available inventory. During sales order processing, the system fulfills inventory on a first-come-first-serve basis. This method can cause the system to backorder critical order lines when item availability is low. The JD Edwards EnterpriseOne Fulfillment Management module enables you to set up a batch process to commit inventory. Auto fulfillment is a batch process that fulfills inventory to open sales orders based upon scoring order lines. During auto fulfillment processing, the system can:

- Completely fulfill inventory when the item availability is high.
- Partially fulfill inventory when the item availability is low.  
The system applies fulfillment rules based on safety stock for partial fulfillment.
- Fulfill none of the inventory when item availability is at or near zero.

The Auto Fulfillment Processing report includes:

1. Sorting order lines based upon the data sequence. You can use information from the Sales Order Detail table (F4211), Sales Order Header table (F4201), and the Customer Master Line of Business (F03012) table for the sold to customer.
2. Fulfilling inventory to sales order lines in the sequence that you specify.
3. Generating a report for the system-created fulfillment plan.

## Auto Fulfillment Processing

The Auto Fulfillment Processing report (R4277701) fills inventory to sales order lines based on:

- Sort sequence of the batch report.  
You can use data from the F4201, F4211, and F03012 tables.
- Inventory Commitment preference percent to fill value.
- Service level rule information
- Fulfillment rule information.
- Rounding rule preference information.

The report produces printed output called a Fulfillment Plan. The Fulfillment Plan provides a list of the order lines that the system considered for fulfillment and the actual results of the fulfillment. You can run the R4277701 report in both Proof and Final mode. In Proof mode, you can review the order lines that the system processed and the potential fulfillment results. The system does not update any tables when you run the report in Proof mode. In Final mode, the system produces the printed output, updates the changes to the database, and enables you to view the results in the Fulfillment Workbench program (P4277701). The system updates the following tables in Final mode:

- Item Location File (F41021).
- Sales Order Detail (F4211).
- Service Level Rule Header (F4277701).

- Service Level Rule Detail (F4277711).
- Fulfillment Plan ID (F4277710).

The system assigns the appropriate Fulfillment Status code to each order line based on whether the line is fully filled, partially filled, not filled, or released from fulfillment.

The system issues warning if:

- The customer does not accept partial shipments in their Customer Billing Information
- The line does not meet the fill requirement.
- The line could not be released, if you set the processing option to automatically call the Release from Fulfillment report (R4277703).

The system issues errors if:

- Records are reserved by another process.
- Records cannot be committed.
- Transaction processing fails.

## Reprocess Fulfillment

The Reprocess Fulfillment processing option enables you to reevaluate sales order lines through the Auto Fulfillment Processing report multiple times. You can use reprocessing with Proof or Final mode of the report. Reprocess enables you to run different scenarios of the fulfillment plan before finalizing and releasing the sales order lines from fulfillment. With reprocessing you can batch sales order lines that are in the fulfillment process and have been assigned inventory with new sales orders that just entered the fulfillment process. For example:

- Receive orders overnight through EDI.
- Run the R4277701 report to assign inventory to the order lines.
- Enter expedited sales order for your top priority customer.
- Run the R4277701 report with reprocessing to evaluate the new expedited order with the existing EDI orders.
  - Reprocess captures the new demand and reassigns inventory appropriately.
  - The system basically un-assigns the previous batch and creates new inventory assigns

**Note:** The auto fulfillment process skips kit item lines and does not process fulfillment for order lines on hold.

## Auto Fulfillment Load Balance

The Auto Fulfillment Load Balance report (R4277711) improves the overall performance of the Auto Fulfillment Processing report (R4277701) by specifying the number of concurrent processes to run. The report splits the load using item and branch combinations. The Auto Fulfillment Load Balance report:

- Determines how many lines in the data selection are eligible for processing.  
The system reserves records to ensure that only records available for processing are included in the total line count. When the system uses an order type service level rule, the system does not process any of the order lines using that same service level rule through the load balancer. Order level rules require the processing of all

related lines in a single transaction. This introduces an additional concurrency constraint by which all item and branch combinations for this order rule type are required to run on a single processor, significantly limiting the value of a load balance.

Sales order lines with an associated order service level rule are not included in the total count because the order must be processed and not as individual lines. The Auto Fulfillment Processing report does not process these order lines when called from the Auto Fulfillment Load Balance report.

- Determines how many lines the system optimally assigns to each concurrent job.
- Determines the maximum number of lines for each concurrent job for the target tolerance percentage range.
- Determines the number of lines the system assigns to each concurrent job and the data selection for the Auto Fulfillment Processing report.

The data selection includes item and branch. The system replaces the data selection of the Auto Fulfillment Processing report with the new data that is determined from the Auto Fulfillment Load Balance report.

For each version of the Auto Fulfillment Processing report that the system launches, you must set up a version of the Auto Fulfillment Load Balance report. The Auto Fulfillment Load Balance report does not have data selection. The system parses the data selection from the Auto Fulfillment Processing report version that you identify in the processing option of the Auto Fulfillment Load Balance report.

- Displays the load balance information on the report.

You must activate the Print processing option.

- Lists error messages on the report and sends them to the Work Center.
- Launches the concurrent version of the Auto Fulfillment Processing report for each job.

You must activate the Run Auto Fulfillment processing option.

This diagram illustrates the Auto Fulfillment Load Balance report output:

R4277711

Oracle - J.D. Edwards  
 Load Balance Auto Fulfillment

**Final Mode**

Total Number of Records: 7.00

Total Number of Item Branch Records: 4

<u>Load Number</u>	<u>Fulfillment Plan ID</u>	<u>Item Branches In Load</u>	<u>Optimal Load Amount</u>	<u>Actual Load Amount</u>
1	3	1	2.33	3.00
2	4	1	2.00	2.00
3	5	2	2.00	2.00

The following Item Branch Combinations could not be processed. Please inspect the work center for additional details:

<u>Item</u>	<u>Branch</u>	<u>Failure Message</u>
BDJACKET1	30	Record Reservation Failure
BDJACKET2	30	Record Reservation Failure
BDJACKET3	30	Record Reservation Failure

## Setting Up Fulfillment Rules

This section provides an overview of fulfillment rules and discusses how to set up fulfillment rules.



## Understanding Fulfillment Rules

The amount of safety stock that you choose to keep on hand can significantly impact your business. If you have too much safety stock, the inventory holding cost increases. Additionally, storing products for too long increases the potential of damage during the warehousing process and some products can spoil or have an expiration date. On the other hand, not having enough safety stock can result in lost sales and unsatisfied customers. Thus, efficient management of safety stock is essential.

The Fulfillment Rules program (P4277720) enables you to set up fulfillment rules that the system uses in the Auto Fulfillment Processing report. The fulfillment rules enable you to manage your safety stock by assigning inventory based on two components—score and safety stock percentage. When processing fulfillment rules, the system evaluates these components to determine whether to apply the fulfillment percentage.

### Understanding Safety Stock

Safety stock is setup in the Item Branch program (P41026). If you use fulfillment rules and an item does not have a safety stock quantity, you must set up a fulfillment rule with zero percent remaining safety stock. The system uses this zero percent rule when an order line cannot be fully filled based on the limiting factor, either item availability or fulfillment percent.

If you use fulfillment rules and subtract safety stock from the on-hand balance in the availability calculation, you must set up a fulfillment rule with zero percent remaining safety stock. When you subtract safety stock in the availability calculation, the system does not hold the additional quantity from being filled to order lines.

If the system does not find an appropriate fulfillment rule during the run of the Auto Fulfillment Processing report, no inventory is filled to the sales order line.

### Scenario: Understanding How the System Applies Fulfillment Rules

In this scenario, four customers order the same item with the same line type and order type. The available quantity for the item is 1,000 units and the safety stock quantity is 200 units. You have set up a fulfillment rule that applies to your item and the customers who order it. This diagram illustrates the fulfillment rule setup:

Sequence No.	Score Range From	Safety Stock Percentage	Fulfillment Percentage
10	0	150%	100%
20	21	140%	100%
30	36	120%	90%
40	51	110%	80%
50	71	100%	75%

During the fulfillment process, the system retrieves the score from the Sales Order Detail table (F4211).

**Note:** In this scenario, the lower the priority score, the more important the priority for the order line.

This table lists the customer, the order line score, and the quantity that each customer ordered:

Customer	Score	Quantity Ordered
4242	15	150
4243	40	400
4244	75	200
4245	10	100

During run of the Auto Fulfillment Processing report, the system assigns inventory to the order lines based upon priority score. This diagram illustrates the results and the sequence in which the system assigns inventory:

Fulfillment Sequence	Customer	Priority Score	Available Quantity	Ordered Quantity	Fulfilled Quantity
1	4245	10	1000	100	100
2	4242	15	900	150	150
3	4243	40	750	400	360
4	4244	75	390	270	0

Safety Stock = 200

The system processes the order lines in sequence based on the priority score. This table explains how the system processes order lines for each customer during auto fulfillment processing in this scenario:

Customer	Comments
4245	<p>The system determines whether 150 percent of the safety stock remains available after assigning 100 percent (100 units) of the requested quantity to the order line for customer 4245. After the system assigns quantity to the order line, the remaining quantity is 900 units, which is more than 150 percent of the safety stock.</p> <p>The system fulfills 100 percent of the quantity ordered for customer 4245 based upon the priority score (10).</p>
4242	<p>After fulfilling quantity for customer 4245, the system:</p> <ul style="list-style-type: none"> <li>Determines whether 150 percent of the safety stock remains available after assigning 100 percent (150 units) of the requested quantity to the order line for customer 4242. After the system assigns quantity to the order line, the remaining quantity is 750 units, which is more than 150 percent of the safety stock.</li> <li>Fulfills 100 percent of quantity ordered for customer 4242 based upon the priority score (15). 750 units are now available.</li> </ul>
4243	<p>After fulfilling quantity for customers 4245 and 4242, the system:</p>

Customer	Comments
	<ul style="list-style-type: none"> <li>Determines whether 140 percent of the safety stock remains available after assigning 90 percent (360 units) of the requested quantity to the order line for customer 4243. After the system assigns quantity to the order line, the remaining quantity is 390 units, which is more than 140 percent of the safety stock.</li> <li>Fulfills 90 percent (360 units) of the quantity ordered for customer 4243 based upon the priority score (30).</li> </ul>
4244	<p>After fulfilling quantity for customers 4245, 4242, and 4243, the system:</p> <ul style="list-style-type: none"> <li>Determines whether 100 percent of the safety stock remains available after assigning 75 percent (202 units) of the requested quantity to the order line for customer 4244. After the system assigns quantity to the order line, the remaining quantity is 188 units, which is less than 100 percent of the safety stock.</li> <li>Does not fulfill the order line.</li> </ul>

## Form Used to Set Up Fulfillment Rules

Form Name	Form ID	Navigation	Usage
Fulfillment Rules - Add Rule	W4277720B	Fulfillment Management Setup (G4277710), Fulfillment Rules Setup.  Click Add.	Set up fulfillment rules.

## Setting Up Fulfillment Rules

Access the Fulfillment Rules - Add Rule form.

### Fulfillment Rule

Enter a code that represents the name of the fulfillment rule.

### Sequence No. (number)

Enter the sequence in which you want the system to evaluate the fulfillment rule.

### Score Range From

Enter the beginning score in the safety stock rule range. When evaluating the safety stock rule, if a number is greater than or equal to the beginning score and less than the next highest beginning score, then the system applies this rule.

### Safety Stock Percentage

For the system to apply the safety stock fulfillment rule, enter the minimum percentage of safety stock that must exist after the system completely fulfills inventory to an order.

### Fulfillment Percentage

Enter a numeric value that determines the percentage of the order quantity that the system fulfills based upon the fulfillment rule. The system does not permit values greater than 100 percent.

## Setting Up Fulfillment Rounding

This section provides an overview of fulfillment rounding and discusses how to set up preference detail values for fulfillment rounding.

### Understanding Fulfillment Rounding

The Fulfillment Rounding advanced preference enables you to set up rounding rules to specify how the system rounds the fulfillment quantity when assigning inventory when you run the Auto Fulfillment Processing report. For example, you can define rounding amounts to the nearest whole number (up or down) or round to the next whole number. You can also specify that the system not perform rounding, thereby enabling the system to use fractions of a unit of measure in fulfillment quantities. You can set up rounding rules based on a combination of item, item group, customer, and customer group. Where rounding occurs depends on the sequence in which the rounding adjustment appears on the advance preference schedule. This example illustrates fulfillment rounding:

- Primary UOM = EA, 1 CA = 12 EA
- Fulfillment percent = 73%

Order Quantity	Transaction UOM	Primary Quantity	Rounding Rule	Fill Quantity	Rounded Fill Quantity	Fill Percent
55	EA	55	2 (Standard)	40.15 EA	40 EA	72.72
10	CA	120	1 (Up)	7.3 CA	8 CA	80

- Note: If the required fill percent is 73%, the first line does not meet the requirement due to rounding.

**Note:** You must set up the Fulfillment Rounding Preference Type with the Level Break Radio Button set to none in the Preference Names (P4071) program. The Auto Fulfillment Processing report (R4277701) does not round quantities to the nearest whole number unless the Level Break Radio Button is set to none.

## Form Used to Set Up Fulfillment Rounding

Form Name	Form ID	Navigation	Usage
Preference Values Revisions	W4072D	<p>Advanced Preferences (G4031), Advanced Preferences Detail Revisions</p> <p>On the Work with Preference Detail form, locate and select a preference name.</p> <p>On the Preference Detail Revisions form, select the record.</p> <p>Select Pref Details from the Row menu.</p>	Set up preference detail values.

## Setting Up Preference Detail Values for Fulfillment Rounding (45)

Access the Preference Values Revisions form.

See *"Setting Up Adjustment Details" in the JD Edwards EnterpriseOne Applications Advanced Pricing Implementation Guide*.

### Sequence

Enter a number that specifies the sequence of information.

### Business Unit

Enter an alphanumeric code that identifies a separate entity within a business for which you want to track costs.

### Transaction Primary

Specify the advanced preference for fulfillment rounding. Values are:

- 1: Transaction equals primary.
- 2: Transaction is not equal to primary.

### Fulfillment Rounding Rule

Specify the rounding rule that the system uses for the Auto Fulfillment Processing report (R4277701). Values are:

- 1: Round up. The system rounds the fulfillment quantity to the next whole number.
- 2: Standard rounding. The system rounds the fulfillment quantity to the nearest whole number (either up or down).
- 3: No rounding. The system does not round the fulfillment quantity. If you do not round, the system can fulfill fractions of a unit of measure.

# Running the Auto Fulfillment Processing Report (R4277701)

This section discusses how to:

- Run the Auto Fulfillment Processing report.
- Set processing options for the Auto Fulfillment Processing report (R4277701).

## Running Auto Fulfillment Processing (R4277701)

Select Fulfillment Processing (G4277710), Auto Fulfillment Processing.

## Setting Processing Options for Auto Fulfillment Processing (R4277701)

Use these options to process orders through the fulfillment process.

### Process

#### 1. Proof or Final Mode.

Specify whether the system runs the Auto Fulfillment Processing report in Proof or Final mode. In Proof mode, the system assigns inventory to sales order lines without modifying the sales order lines, and does not update the status of the lines. In Final mode, the system commits the output, creates the fulfillment plan, and updates the order statuses. Values are:

Blank: Run Auto Fulfillment in Proof mode.

1: Run Auto Fulfillment in Final mode.

**Note:** When you run this version of Auto Fulfillment in proof mode, the system does not launch the Release from Fulfillment report (R4277703). When you run this version of Auto Fulfillment in final mode, the system launches the Release from Fulfillment report. However, if the system launches this version of Auto Fulfillment from the Load Balancer report (R4277711), the system does not run the Release from Fulfillment report regardless of whether you set this version to run in proof mode or in final mode.

#### 2. Fulfillment Plan Description.

Enter a value that defines the fulfillment plan. In Final mode, the system writes the fulfillment plan to the Fulfillment Plan ID table (F4277710). This description is informational only.

#### 3. Include Backordered Quantity as Available Quantity.

Specify whether the system adds back-ordered quantity to available quantity. Use this processing option depending on how you set up the availability calculation. Values are:

Blank: Do not add back-ordered quantity to available quantity.



**1:** Add back-ordered quantity to available quantity.

#### **4. Release the fulfillment after orders are fulfilled.**

Specify whether the system runs the Release from Fulfillment report (R4277703). Values are:

Blank: Do not run the Release from Fulfillment report.

**1:** Run the Release from Fulfillment report.

**Note:** The system runs the Release from Fulfillment report only when you run the Auto Fulfillment Processing report in Final mode. However, if the system launches this version of Auto Fulfillment from the Load Balancer report (R4277711), the system does not run the Release from Fulfillment report regardless of whether you set this version to run in proof mode or in final mode

#### **5. Fulfillment Rule Name**

Enter the rule name that you set up in the Fulfillment Rules program (P4277720). This functionality enables inventory assignments based on the scores and remaining percentage of the safety stock.

#### **6. Reprocess Fulfillment**

Indicate whether the system reprocesses the existing fulfillment. Reprocessing enables you to un-commit previous inventory assignments and run the process from the beginning. Values are:

Blank: The system does not reprocess the fulfillment.

**1:** The system reprocesses the fulfillment.

#### **7. Record Reservation Error**

Specify whether you want the Auto Fulfillment Processing report to provide error messaging on all reserved records, or only on the first reserved record that the system encounters. When record reservation is active, the Auto Fulfillment Processing report runs through all the data selection and determines whether the system has reserved any of the records. If the system has reserved records, the system issues errors, stops the Auto Fulfillment Processing report, and does not process any order lines. Values are:

Blank: Set record reservation error and continue looking for additional reservations.

**1:** Stop processing the program when the first record reservation error occurs.

#### **8. Override Advanced Preference**

Specify the advanced preference schedule that the system uses when resolving the Fulfillment Rounding preference. If you leave this processing option blank, the system uses the schedule from the system constants.

## Versions

These processing options specify the versions of programs that the system calls from the Auto Fulfillment Processing report. When you choose a version, review the version's processing options to ensure that the version meets your needs. You can define different versions in accordance with business processes. If you leave any of the processing options blank, the system uses version ZJDE0001, which is the default version for each respective program.

#### **1. Release from Fulfillment (R4277703)**

XJDE0001

#### **2. Sales Order Entry (P4210)**

ZJDE0001

# Running the Auto Fulfillment Load Balance Report (R4277711)

This section discusses how to:

- Run the Auto Fulfillment Load Balance report.
- Set processing options for the Auto Fulfillment Load Balance report (R4277711).

## Running Auto Fulfillment Load Balance

Select Fulfillment Processing (G4277710), Auto Fulfillment Load Balance.

## Setting Processing Options for the Auto Fulfillment Load Balance Report (R4277711)

Use the following processing options to process orders through the fulfillment process.

### Process

#### 1. Number of Concurrent Jobs

Specify the number of times that the system runs a version. Typically this number corresponds to the number of processors on a system. You can run the version concurrently on different processors to reduce processing time. The Auto Fulfillment Load Balance report (R4277711) launches a version of the Auto Fulfillment Processing report (R4277701) multiple times, and distributes the sales detail records over the versions.

#### 2. Version of Auto Fulfillment

Specify the version of the Auto Fulfillment Processing report (R4277701) that the system runs. If you leave this processing option blank, the system uses version XJDE0001.

#### 3. Run Auto Fulfillment

Specify whether the Auto Fulfillment Load Balance report (R4277711) runs the Auto Fulfillment Processing report (R4277701). Values are:

Blank: Do not run the Auto Fulfillment Processing report (R4277701).

1: Run the Auto Fulfillment Processing report (R4277701).

**Note:** When you set the Load Balancer report to run Auto Fulfillment, the system does not run the Release from Fulfillment report (R4277703) regardless of whether you set the version of Auto Fulfillment report to run in proof or final mode. This eliminates record reservation conflicts for the sales orders potentially being processed by both the Load Balancer for Auto-Fulfillment and the Release from Fulfillment report.

## Print

### 1. Print Load Balance Information

Specify whether the system prints load balance information in a report. Values are:

Blank: Do not print load balance information.

**1:** Print load balance information.

## Running the Purge Fulfillment Plan ID Report (R4277710)

This section discusses how to run the Purge Fulfillment Plan ID report.

The Fulfillment Plan is a set of order lines that the system designates to be fulfilled. The Auto Fulfillment Processing report produces an initial fulfillment plan and assigns a Fulfillment Plan ID to all of the order lines that the system considers. You can use the Fulfillment Workbench program (P4277701) to validate and change the order lines in the fulfillment plan.

The Purge Fulfillment Plan ID report (R4277710) determines whether a Fulfillment Plan ID exists within the specified data selection for the Fulfillment Plan ID table (F4277710) and in the Sales Order Detail table (F4211). The system does not purge the record from the F4277710 table if records exist in the F4211. If no records match the specified data selection, the system displays a message indicating that no data has been selected.

## Running Purge Fulfillment Plan ID

Select Fulfillment Management Advanced & Technical Ops (G4277730), Purge Fulfillment Plan ID.

**Note:** This report does not have processing options.



# 7 Using the Fulfillment Workbench

## Understanding the Fulfillment Workbench

The Fulfillment Workbench program (P4277701) enables you to manage fulfillment quantities for sales order detail lines. The Fulfillment Workbench provides different types of filters that you can use to search for information and enables you to:

- View and modify the inventory commitments on fulfillment sales order lines.
- Interactively adjust the assignment of inventory to sales order lines, using both primary and secondary units of measure.
- Review the items and customers that have unfulfilled quantities on sales order lines.
- Changes the branch plant and promised delivery date.
- Release order lines from fulfillment.

The Fulfillment Workbench program enables you to select the order lines to release from fulfillment. When you release partial quantity for fulfillment, the system splits the order lines and optionally sends E-mail notifications to interested parties.

When you search for information, the Fulfillment Workbench program displays:

- Sales order lines that are currently in the fulfillment process and match the filtered criteria that you enter in the header and QBE fields.
- You can filter the list by status, date range, item, order type, line type, sold to, and fulfillment plan ID.
- Unfulfilled quantities for the item, branch, and availability information for those items.
  - A summary of the customers that have unfulfilled sales order lines in the fulfillment process.

## Understanding Availability Information

The Fulfillment Workbench program displays inventory availability information for the items in the fulfillment process. When you select the Unfilled Items with Sales Order Lines option in the workbench, the system shows a fulfillment availability chart to visually aid you in fulfillment decisions. The system displays one of four available charts based on the item that is selected:

- Fulfillment Available. Indicates that you have enough inventory to meet all demand.
- Fulfillment Shortfall. Indicates you do not have enough inventory to meet demand
- Fulfillment Exceeds Safety Stock. Indicates that you have enough inventory to meet demand, but you may dip into the safety stock.
- Fulfillment Expected. Indicates that you do not have enough inventory to meet demand, but purchase orders or work orders are open for the item.

You can change how the system fulfills order lines by selecting and editing multiple sales order lines. The Fulfillment Workbench Edit form includes an Item Availability Information section to help you make decisions on the modifications to inventory assignments.

# Setting Processing Options for the Fulfillment Workbench Program (P4277701)

Use these processing options to define default search information for the Fulfillment Workbench program and to specify the versions of programs that the system calls from the Fulfillment Workbench program.

## Defaults

These processing options control default search information for the Fulfillment Workbench Search form

### 1. From Status

Indicate the current point in the order process. You must specify an Order Activity Rule user defined code (40/AT) based on the order type and the line type that you are using.

The combination of the beginning status and next status must be a valid last status and next status combination in the Order Activity Rules table. During order inquiry, the system does not display orders that are not within the beginning and next status range.

### 2. To Status

Indicate the next step in the order process. You must specify an Order Activity Rule user defined code (40/AT) based on the order type and the line type that you are using.

The combination of the beginning status and next status must be a valid last status and next status combination in the Order Activity Rules table. During order inquiry, the system does not display orders that are not within the beginning and next status range.

### 3. Search on Last or Next Status

Specify which status codes the system uses to choose information to display on this screen. Values are:

Blank: Display all orders with a Last status that falls within this range.

1: Display all orders with a Next status that falls within this range.

### 4. From Date

Specify the from date default value that the system uses in the From Date filter field.

### 5. To Date

Specify the to date default value that the system uses in the To Date filter field.

### 6. Date Range Type

Indicate the date value from the Sales Order Detail File table (F4211) with which the system searches on orders. Values are:

Blank: The system retrieves orders based on the requested date.

1: The system retrieves orders based on the order entry date.

2: The system retrieves orders based on the promised ship date that the system populates during order entry.

3: The system retrieves orders based on the original promised date that is populated during order entry.

**4:** The system retrieves orders based on the date that the system confirms the for shipment. The system retrieves only those orders that the Shipment Confirmation program (P4205) has processed.

**5:** The system retrieves orders based on the date that the system printed the invoice for the customer. The system retrieves only those orders that the Print Invoice report (R42565) has processed.

**6:** The system retrieves orders based on the date that you enter in the memo-only, cancel field during order entry.

**7:** The system retrieves orders based on the G/L date. The system retrieves only those orders that the Sales Update report (R42800) has processed.

**8:** The system retrieves orders based on the promised delivery date that you enter at order entry.

**9:** The system retrieves orders based on the scheduled pick date for the order.

#### **7. Branch Plant**

Specify the branch plant that the systems uses as the default value in the Branch Plant filter field. If you leave this field blank, the system uses the value stored in the Default Location/Printers table (F40095).

#### **8. Item Number**

Specify the item number the system uses as a default value in the Item filter field.

#### **9. Sold To Customer Number**

Specify the sold to address book number the system uses as a default value in the Sold To filter field.

#### **10. Order Type**

Specify the order type the system uses as a default value in the Order Type filter field.

#### **11. Show Unfulfilled Items Customers with Sales Orders**

Specify the default option that the system uses to control the display of unfulfilled items and customers. Values are:

Blank: Sales Orders Only.

**1:** Unfulfilled Items with Sales Orders.

**2:** Unfulfilled Customers with Sales Orders.

#### **12. Default Display of Kit Components**

Specify whether the system displays kit components by default on the Fulfillment Workbench Search form. Values are:

Blank: Hide components. If you hide components by default, you can expand the components manually on the grid.

**1:** Display components.

## Process

These processing options control default processing options for the Fulfillment Workbench.

#### **1. Availability Notification**

Indicate whether the system notifies the user when the fulfill quantity exceeds the quantity available. Values are:

Blank: The system does not set a warning or an error when the fulfill quantity for this item exceeds the available quantity.

**1:** The system sets a warning when the fulfill quantity for this item exceeds the available quantity.

2: The system sets an error when the fulfill quantity for this item exceeds the available quantity.

### 2. Back Order Quantity as Available Quantity

Specify whether the system adds the backordered quantity to the available quantity. This option enables more available quantity to fill orders depending on our availability calculation. Values are:

Blank: Do not add backorder quantity to available quantity.

1: Add backorder quantity to available quantity.

### 3. Refresh Item Availability

Indicate whether the system automatically regenerates item availability. Values are:

Blank: The system provides a refresh button so that you can interactively update the information.

1: The system automatically updates the information each time you select a new grid row.

## Versions

These processing options specify the versions of programs that the system calls from the Fulfillment Workbench program. When you choose a version, review the version's processing options to ensure that the version meets your needs. You can define different versions in accordance with business processes. If you leave any of the processing options blank, the system uses version ZJDE0001, which is the default version for each respective program.

This table lists the programs in the order that they appear on the Versions tab:

#### 1. Sales Order Model (P4210)

ZJDE0001

#### 2. Sales Order Entry (P42101)

ZJDE0001

#### 3. Release from Fulfillment (R4277703)

XJDE0001

#### 4. Customer Detail (P90CA080)

ZJDE0001

#### 5. Summary Availability (P41202)

ZJDE0001

## Working with the Fulfillment Workbench

This section discusses how to:

- Review fulfillment information.
- Edit fulfillment information.



## Forms Used to Work with the Fulfillment Management Workbench

Form Name	Form ID	Navigation	Usage
Fulfillment Workbench - Search	W4277701A	Fulfillment Processing (G4277710), Fulfillment Workbench	View and modify the inventory assigned on fulfillment sales order lines.
Fulfillment Workbench - Edit	W4277702A	Select a sales order detail line and click the Edit Fulfillment button.	Edit fulfillment information such as branch plant, fulfill quantity, and promised delivery date.

## Reviewing Fulfillment Information

Access the Fulfillment Workbench - Search form.

### Fulfillment Plan ID

Specify the ID that the system generates when you run the Auto Fulfillment Processing report. This ID is based on a next number. This ID is assigned to sales order detail records that are processed by an Auto Fulfillment Processing report run.

### Branch Plant

An alphanumeric code that identifies a separate entity within a business for which you want to track costs. For example, a business unit might be a warehouse location, job, project, work center, branch, or plant.

### Date Type

Specify the type of date that the system searches for when finding information to display on this form. Values are:

Blank: Requested date.

**1:** Transaction / order date.

**2:** Promised ship date.

**3:** Original promised delivery date.

**4:** Actual ship date.

**5:** Invoice date.

**6:** Cancel date.

**7:** General ledger date.

**8:** Promised delivery date.

**9:** Scheduled pick date.

### Unfulfilled Items with Sales Order Lines

Select this option to indicate whether the system displays the fulfillment sales order lines by Unfulfilled Items and filters orders based upon items.

**Unfulfilled Customers with Sales Orders**

Select this option indicate whether the system displays the fulfillment sales order lines by Unfulfilled Customers and filters orders based upon customers.

**Sales Order Lines Only**

Select this option to indicate whether the system displays all the sales order lines in the fulfillment process.

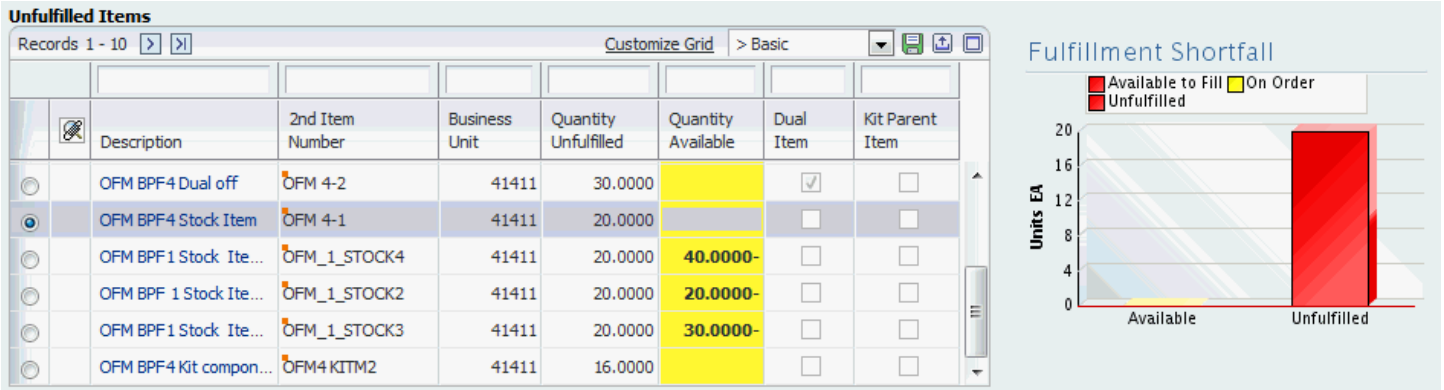

**Sales Order Lines--for-OFM BPF4 Stock Item**

Records 1 - 2

Order Number	Or Ty	Line Number	Customer Sold To	Customer Sold To Name	Fulfilled Quantity	Unfulfilled Quantity
131	SO	1.000	81151	OFM Customer #2 ...		10.0000
130	SO	1.000	81150	OFM Customer #1 ...		10.0000

**Unfulfilled Customers**

Records 1 - 5 Customize Grid > Basic

		Sold to Address Number	Sold To Address name	Priority	Credit Message
<input checked="" type="radio"/>		4242	Capital System DO NOT MODIFY	0	.
<input type="radio"/>		4245	Cloud Nine Inc.	0	.
<input type="radio"/>		81150	OFM Customer #1 BPF3	A	.
<input type="radio"/>		81151	OFM Customer #2 BPF3	B	.
<input type="radio"/>		427771	Fulfillment Customer #2 BPF1	B	.

**Sales Order Lines--for-Cloud Nine Inc.**

Records 1 - 1

		+/-	Order Number	Or Ty	Line Number	Customer Sold To	Customer Sold To Name	Fulfilled Quantity	Unfulfilled Quantity
<input type="checkbox"/>			8222425	SO	1.000	4245	Cloud Nine Inc.		3.0000

## Editing Fulfillment Information

Access the Fulfillment Workbench - Edit form.

### Item Availability

#### Safety Stock

The quantity of stock kept on hand to cover high-side variations in demand.

You designate the safety stock in the Item Branch Quantities form.

#### Included in Availability Calculation

This option indicates whether the system reduces the number of units reserved as safety stock from the item availability calculation as defined in the branch plant constants item availability definition.

## Quantity Available

A number that indicates the quantity that is available. For example, the available quantity might consist of the on-hand quantity minus commitments, reservations, and backorders. Availability is user defined. You can set up availability in the Branch/Plant Constants program (P41001).

## Quantity On Hand

The number of units that are physically in stock. The system displays the quantity on-hand in the primary unit of measure.

There are three ways in which you can access item availability:

1. The Item Availability section at the top of the Fulfillment Workbench – Edit form which displays availability information for the grid row that you select.
2. You can select the Change Branch Plant button to display availability for all branch plants associated with the item on the grid row that you select.
3. You can select Summary Availability from the Other Row Actions menu to access the Work with Item Availability form, which displays availability information for the grid row that you selected.

The system displays a green check mark next to the grid line when inventory for an item is available in another branch plant.

## Editable Fields

You can use the Fulfillment Workbench – Edit form to change these values:

- Transactional and secondary fulfill quantities.
  - a. When you change fulfillment quantities, the system updates the soft commitment quantities reflected in the Item Availability section.
  - b. If you modify an item for which fulfill quantities is a dual item with dual picking processing, the system processes availability checking and messaging for the secondary quantity.
- Promised delivery date.
- Branch plant.

If you change the branch plant and if the alternate tax rate/area assignment functionality is enabled, the system attempts to retrieve the alternate tax rate/area based on the company associated with the new branch plant and the ship to address. If no errors occur, then the system displays the alternate tax rate/area in the Tax Area field and recalculates:

- The tax based on the new tax rate/area.
- The taxed unit prices if that functionality is enabled.

If an error occurs, then the system displays an error message according to the alternate tax rate/area definition, does not update the Tax Rate field, and does not recalculate the taxes.

See *"Setting Up Alternate Tax Rate/Area Assignment Functionality" in the JD Edwards EnterpriseOne Applications Tax Processing Implementation Guide* .

If the alternate tax/rate area assignment functionality is not enabled when you change the branch plant, then the system does not retrieve the tax rate/area associated with the new branch plant and does not recalculate taxes.

- Service Level Rule Order and Line Rule Evaluation Required flags.

## Kit Processing

On the Fulfillment Workbench — Edit form, the system designates a kit parent by displaying a + sign on the order line grid row. The system designates kit components by displaying a ~ sign on the order line grid row.

You can use the Fulfillment Workbench – Edit form to change the information on a kit parent order line as a regular stock item. The system determines availability for the kit parent by using the availability for the limiting component. The limiting component is determined by calculating the product of the lowest availability across all components on the kit and the parent component ratio.

The system balances the kit components by adjusting the fulfill quantities for all of the components based on the parent to child ratio and updates the components filled quantity accordingly.

## Requirement Processing

Category	Comments
Partial Shipments	If you partially fulfill an order line for a customer who does not accept partial shipments, the system displays a warning to indicate that the order line does not allow partial shipments and the order line does not qualify for release from the Fulfillment Management system.
Inventory Commitment Preference Percent to Fill	<p>If no service level rule is associated to the order line and the system resolves the inventory commitment preference for the order line, then the system displays the percent to fill requirement on the Fulfillment Workbench – Edit form grid. Upon updating the fulfill quantity for the order line, the system evaluates whether the fulfill quantity meets the percent to fill requirement. If the fulfill quantity does not meet the percent to fill requirement, the system displays a warning indicating the requirement has not been met and the order line does not qualify for release from the Fulfillment Management system.</p> <p>If you change the branch plant on the order line, the system clears the percent to fill value because the inventory commitment preference is not reevaluated and the percent to fill requirement is not valid for the selected branch plant.</p>
Service Level Rules	<p>If an order line is associated to both an inventory commitment preference percent to fill and a service level rule requirement, the service level rule requirement overrides the inventory commitment preference. The system does not display the associated inventory commitment percent to fill within the grid for the order line on the Fulfillment Workbench – Edit form.</p> <p>When updating fulfill quantity for an order line with a service level rule, the system evaluates whether the change to the fulfill quantity effects the service level rule requirements and displays corresponding warnings if requirements are not met. If the Rule Evaluation Required flag is set, the system deselects the flag.</p> <p>When using the Fulfillment Workbench - Edit form to revise order lines with associated order type service level rules, the first line that you select and modify alerts the system to evaluate the rule requirement. The system evaluates all order lines on the order with an associated order rule to determine whether the established requirements are met by the fulfilled quantities. The system sets warning messages regarding the order rule requirements and the line level rule requirements.</p> <p>If you define service level rules as custom function rules, messaging is not provided unless by the custom function. If the order contains both order level custom program and order fill percentage rules, the system overrides the order fill percentage with the order custom program and displays only the order custom function rule in both the Fulfillment Workbench – Edit and Search form grids.</p> <p>When you change a branch plant, the system reevaluates whether the order line qualifies for a service level rule based on the new branch plant value. If the branch plant change occurs on an order line with an associated order type rule, the system reevaluates the entire order for requirement status based on the new service level rule associated to the changed order line.</p>

Category	Comments
	If the Order and Line Rule Evaluation Requirement flags are selected, you can either deselect the flag on the order line or update its fulfill quantity to initiate processing to reevaluate the requirement met status of the line. And, for an order level type rule on the current line, reevaluate all other order line requirement statuses on the order with order level types rule association.
Free Good Line Processing	Free good line processing within the Fulfillment Workbench – Edit form is similar to sales order entry processing. The system displays the free goods lines in the same manner as both the sales order and the Service Level Rule Inquiry/Override program, the free good line is highlighted. Modification of any of the editable fields on the parent order line of free good lines in the Fulfillment Workbench – Edit form grid (except the Rule Evaluation Required flag) could cause the system to cancel the associated free good order line and create a new order line. The new order line is not visible until you close the Fulfillment Workbench – Edit form, and then access the form again.

# 8 Releasing Order Lines from Fulfillment

## Understanding Release from Fulfillment

The Release from Fulfillment report (R4277703) releases orders from the JD Edwards EnterpriseOne Fulfillment Management system. After order line are released from fulfillment, they can continue through the sales order processing tasks.

To process the service level rules, the Release from Fulfillment report validates the line and order service level rule met flags value in the Service Level Rule Detail table (F4277711). You can run the Release from Fulfillment report by accessing the report directly or launching it from the Fulfillment Workbench program (P4277701) or from the Auto Fulfillment Processing report (R4277701).

The system releases the line based on the flag values. The Release from Fulfillment report also considers the cancel flag from the F4277711 table and the partial commit flag from the Customer Master Line of Business table (F03012) during split-line processing. The four scenarios for release from fulfillment include:

1. Release fulfillment with line a level rule type. The system retrieves the line percent met flag value from the Service Level Rule Detail table to determine whether to release the line from fulfillment. If the line level rule met flag value is **1**, the system releases the line from fulfillment. If the line level rule met flag value is **0**, the system does not release the line and issues an error message that the system could not release line.
2. Release fulfillment with an order level rule type. The system retrieves the order and line percent flags from the Service Level Rule table to determine whether to release the line and order from fulfillment. If the order and line level service level rule met flags value are **1**, the system releases the appropriated lines from fulfillment and sets the order released line flag to **1** in the Service Level Header table (F4277701). If the order level rule met flag value is **0**, the system does not release any lines on the order with the order level rule and issues an error message that the system could not release the order.
3. Release fulfillment and cancel balance. For lines that are partially filled or split, the system cancels the split line. The system retrieves the cancel flag setting from the F4277711 table to determine whether to cancel the open balance.
4. Release fulfillment and split line. For lines that are partially filled, the system splits the line and increases the release number by 1. Additionally, the system retrieves the service level rules and returns the service level rule information for the new split line and release number.

## Understanding Fulfillment Message Notification

You can set up the Message Notification preference (35) to send an email notification to a user-defined party. For JD Edwards EnterpriseOne Fulfillment Management, you can send the email notification from the Release from Fulfillment report (R4277703) when a sales order line is not fully filled. The email includes basic information about the sales order line such as customer, quantity ordered, quantity released, quantity filled, and quantity unfilled. The email notification enables proactive communication with customers instead of reactive communication when the order line cannot be filled to customer requirements.

**Note:** To enable message notification, you must set the Internet Enable PPAT Messages option in the System Constants.

## Setting Up Fulfillment Message Notifications

This section discusses how to set up preference detail values for message notifications.

You use the Message Notification (Preference Type 35) preference to specify which address book number to use for sending fulfillment notifications.

### Form Used to Set Up Message Notifications

Form Name	Form ID	Navigation	Usage
Preference Values Revisions	W4072D	<p>Advanced Preferences (G40311), Advanced Preferences Detail Revisions</p> <p>On the Work with Preference Detail form, locate and select a preference name.</p> <p>On the Preference Detail Revisions form, select the record.</p> <p>Select Pref Details from the Row menu.</p>	Set up preference detail values.

### Setting Up Preference Detail Values for Message Notification (35)

Access the Preference Values Revisions form.

See *"Setting Up Adjustment Details" in the JD Edwards EnterpriseOne Applications Advanced Pricing Implementation Guide*

#### Sequence

Enter a number that specifies the sequence of information.

#### Business Unit

Enter an alphanumeric code that identifies a separate entity within a business to which you want to send message notifications. For example, a business unit might be a warehouse location, job, project, work center, branch, or plant.

#### Notification Type

Specify the source of the notification preference. Values are:

**00:** Net Variance.

**01:** Sales Orders.



- 02:** Forecast/Planning.
- 03:** INVRPT (Inventory Advisement).
- 04:** ASN.
- 05:** CUM.
- 06:** Adjust Demand.
- 07:** Inbound Demand.
- 08:** Acknowledgments.
- 09:** EDI Maintenance.
- 10:** Carton Recommendation Errors.
- 11:** Fulfillment Notification.

You must use this value to send messages from the Release from Fulfillment report (R4277703).

**Notification A/B (notification address book)**

Specify the address book record to which you want the system to send messages or notifications. The system uses the email addresses that you set up in the Who's Who record of the Address Book.

## Running the Release from Fulfillment report (R4277703)

The section discusses how to:

- Run the Release from Fulfillment report.
- Set processing options for the Release from Fulfillment report (R4277703).

### Running the Release from Fulfillment Report

Select Fulfillment Processing (G4277710), Release from Fulfillment.

### Setting Processing Options for Release from Fulfillment (R4277703)

These processing options control override processing and message notifications for the Release from Fulfillment report.

#### Process

##### 1. Override Next Status

Specify the next status in the order process.

Setting the override status is optional in the release from fulfillment process. The combination of the beginning status and the override next status must be a valid last status and next status combination in the order activity rules.

## 2. Update Next Status

Specify whether the system updates the line status.

Blank: Update line status.

**1:** Do not update line status.

The system moves the order line to the next status codes set up in the order activity rules.

## 3. Remove Unreleased Sales Order Lines from Existing Shipment

Specify whether the system removes unreleased sales order lines from an existing shipment, and assigns a new shipment number to the unreleased sales order lines. Values are:

Blank: Do not remove unreleased sales order lines from an existing shipment. All sales order lines remain on the original shipment.

**1:** Remove unreleased sales order lines from an existing shipment and assign a new shipment number based on the shipment consolidation mode setup in the Transportation Constants program (P49002). The released sales order lines remain on the original shipment.

When you set this processing option to the value **1**, the Release from Fulfillment report writes the selected sales order shipment number into the Released Shipments Workfile table (F427UI03) and runs the Remove Unreleased Lines from Shipments report (R4277707), which assigns a new shipment number.

## E-mail

### 1. E-mail Acknowledgement Selection

Indicate whether the system sends email acknowledgements when you run the Release from Fulfillment report (R4277703). Values are:

Blank: The system does not send email acknowledgements.

**1:** The system sends email acknowledgements.

### 2. E-mail Subject Line

Specify the print message that the system prints in the subject line when sending an E-mail acknowledgment. If you leave this processing option blank, the system leaves the subject line blank on the associated E-mail.

### 3. E-mail Sender Address Number

Specify the address number for the entity whose name and E-mail address the system uses on the E-mail acknowledgment as the sender.

### 4. Override Schedule For Advanced Preference

Specify an override preference schedule for the system to use instead of the default preference schedule defined in the system constants.

The Message Notification preference (35) must be in the schedule that the system uses to send email notifications.

**Note:** You can use the Advanced Preferences Schedule Revisions program (P4070) to modify preference schedules.

## Versions

### 1. Remove Unreleased Lines from Shipment (R4277707)

Specify the version of the Remove Unreleased Lines from Shipment report (R4277707) that the system uses to remove unreleased lines from the existing shipment number. If you leave this option blank, the system uses version XJDE0001.

# Running the Remove Unreleased Lines from Shipments Report (R4277707)

This section provides an overview of the Remove Unreleased Lines from Shipments report (R4277707) and discusses how to:

- Run the Remove Unreleased Lines from Shipments report.
- Set processing options for the Remove Unreleased Lines from Shipments report (R4277707).

## Understanding the Remove Unreleased Lines from Shipments Report

If you are processing sales orders through the JD Edwards EnterpriseOne Transportation Management system, the system assigns shipment numbers to order lines at sales order entry. If the system does not allocate inventory to sales order lines when you run the Release from Fulfillment report, the unreleased sales order lines remain on the same shipment number as the released sales order lines. When this occurs, the system does not process shipments until all of the sales order lines have been released.

The Remove Unreleased Lines from Shipments report provides the ability to remove unfulfilled sales order lines from their existing shipment number. This report runs independently from the Release from Fulfillment report based on business process or based on the need to recover from record reservation errors that prohibited the initial removal of unfulfilled lines.

When you run the Remove Unreleased Lines from Shipments report, the system:

- Keeps all of the fully released lines and partially released lines on the original shipment number.
- Creates a new shipment number for partially unreleased lines when the sales order contains:
  - Some lines fully released.
  - Some lines partially released.
  - Some lines fully unreleased.
- Activates record reservation for the selected unreleased sales order lines.
- Verifies whether the sales order line is part of a kit item.

If the item is a kit item, the system retrieves the related components and processes the kit parent component to assign a new shipment number to the unreleased order lines.

- Generates a PDF report that includes the order number, order type, company, line number, previous shipment number, new shipment number, and error ID.
- Sends a message to the Work Center.

- Releases record reservation.
- Deletes records from the Released Shipments Workfile table (F427UI03).

## Running the Remove Unreleased Lines from Shipments Report

Select Fulfillment Processing (G4277710), Remove Unreleased Lines from Shipments.

## Setting Processing Options for Remove Unreleased Lines from Shipments (R4277707)

This processing option governs report output.

### Process

#### 1. Output

Specify whether to suppress the report output. Values are:

**1:** Suppress report output.

Blank: Do not suppress report output.

# 9 Appendix A - Scoring Examples

## Basic Scoring Example

The appendix illustrates scoring using basic scoring and advance preference scoring.

This diagram shows basic scoring setup where the system assigns a score based upon:

- Order Type = SO
- Line Type = S
- Customer Priority ranges from 90 to 500.

**Basic Scoring Setup**

Order Type  Line Type

**Customer Priority** From:  To:

**Requested Date Age** From:  To:

**Custom Function Priority** From:  To:

Select a Query   
[Save Query](#) [Edit Queries](#)

Records 1 - 10

<input type="checkbox"/>	<input type="checkbox"/>	Customer Priority From	Order Type	Requested Date Age From	Line Type	Custom Function Priority From	Order Score
<input type="checkbox"/>		90.000	SO	999-	S	.000	155.000
<input type="checkbox"/>		90.000	SO		5 S	.000	80.000
<input type="checkbox"/>		90.000	SO		10 S	.000	50.000
<input type="checkbox"/>		90.000	SO		40 S	.000	13.000
<input type="checkbox"/>		100.000	SO	999-	S	.000	160.000
<input type="checkbox"/>		100.000	SO		5 S	.000	85.000
<input type="checkbox"/>		100.000	SO		10 S	.000	55.000
<input type="checkbox"/>		100.000	SO		40 S	.000	14.000
<input type="checkbox"/>		500.000	SO		5 S	.000	170.000
<input type="checkbox"/>		500.000	SO		10 S	.000	100.000

**Example 1** 

**Example 2** 

**Example 3** 

The system searches for a match of the criteria and assigns the score accordingly. For example, if today's date is October 1st and you enter a sales order today and the requested date is October 3rd, the requested date age is 2. The system retrieves the information from the line where the requested date age range begins at 999- and retrieves an order score of 160 because 2 is greater than or equal to -999 but less than 5 (Example 1). If the requested date is October 7th, then the requested date age is 6 and the system retrieves the line where the requested date age range begins at 5 because 6 is greater than or equal to 5 and less than 10. Hence, the system retrieves an order score of 85 (Example 2). If the customer priority is 250 and the requested date is October 31st, then the requested date age is 30. The system retrieves the line where the customer priority range begins at 100 and the requested date range begins at 10. The system chooses this line because the customer priority (250) is greater than or equal to 100 but less than 500 and the requested date age (30) is greater than or equal to 10 but less than 40. Therefore, the system retrieves an order score of 55 (Example 3).

## Advance Preference Scoring

This diagram shows the setup for the order type priority and line type priority preferences. The order type priority preference setup indicates that the system retrieves a value of 100 for an SO order type. The line type priority preference setup indicates that the system retrieves a value of 60 for an S line type.

## Score Orders with Advanced Scoring – Determining Priority

Preference Name  *BD Order Type Prio*  
 Advanced Preference Type  *Order Type Priority*

Records 1 - 4 <span style="float:right">Customize Grid</span>			
<input type="checkbox"/>	Sequence	Or Ty	Order Type Priority
<input type="radio"/>	10.00	SO	100.000
<input type="radio"/>	20.00	S4	90.000
<input checked="" type="radio"/>	30.00	<input type="text" value="S8"/>	<input type="text" value="80.000"/>
<input type="radio"/>			

Preference Name  *BD Line Type Prio*  
 Advanced Preference Type  *Line Type Priority*

Records 1 - 4 <span style="float:right">Customize Grid</span>			
<input type="checkbox"/>	Sequence	Ln Ty	Line Type Priority
<input type="radio"/>	10.00	S	60.000
<input type="radio"/>	20.00	I	80.000
<input checked="" type="radio"/>	30.00	<input type="text" value="X"/>	<input type="text" value="100.000"/>
<input type="radio"/>			

This diagram shows the setup for requested date age priority. The sequence is logical to reflect requested dates that range from -99999 to greater than 40. The system retrieves a requested date priority scores based on the range:

- Requested dates greater than or equal to -9999 thru 4.999 receive a score of 150.
- Requested dates greater than or equal to 5 thru 9.9999 receive a score of 100.



- Requested dates greater than or equal to 10 thru 39.9999 receive a score of 50.
- Requested date greater than or equal to 40 receive a score of 10.

## Score Orders with Advanced Scoring – Determining Priority





Preference Name  *BD Request Date Age*  
Advanced Preference Type  *Order Age Priority*

Records 1 - 5		Customize Grid		
		Sequence	Days until Requested Date	Requested Date Priority
<input type="radio"/>		10.00	-99999	150.000
<input type="radio"/>		20.00	5	100.000
<input type="radio"/>		30.00	10	50.000
<input checked="" type="radio"/>		40.00	<input type="text" value="40"/>	<input type="text" value="10.000"/>
<input type="radio"/>				

This shows the processing options for the Fulfillment Batch Scoring report (R4277702). The weight factors must total 100. The system multiplies the values for each priority by their respective weight factor and sums the total to produce the total score.

## Score Orders with Advanced Scoring - Weighting

### Processing Options

 OK	 Cancel
	

Process	
1. Scoring Method	<input type="text" value="1"/>
Blank = Basic 1 = Advanced	
2. Weight Factor for Order Type Priority Preference	<input type="text" value="5.00"/>
3. Weight Factor for Line Type Priority Preference	<input type="text" value="10.00"/>
4. Weight Factor for Customer Sold To Priority	<input type="text" value="35.00"/>
5. Weight Factor for Requested Date Priority Preference	<input type="text" value="50.00"/>
6. Weight Factor for Custom Priority	<input type="text"/>
7. Custom Priority Calculation Function	<input type="text"/>
8. Override Advanced Preference Schedule	<input type="text" value="BETADEMO"/>
9. Set warning when basic score is not found	<input type="text"/>
Blank = Do not set warning 1 = Set warning	

The system calculates the score for the order lines using the weight factors and determines a weighted average. The system calculates the score using the formula:

$$\text{Score} = [(\text{Order Type Priority} \times \text{Order Type Weighted Percent}) + (\text{Line Type Priority} \times \text{Line Type Weighted Percent}) + (\text{Requested Date Priority} \times \text{Requested Date Age Weighted Percent}) + (\text{Customer Priority} \times \text{Customer Weighted Percent}) + (\text{Custom Business Function Priority} \times \text{Custom Business Weighted Percent})]$$

This diagram is a detail example of how the system calculates the score using advanced preferences.

## Score Orders with Advanced Scoring - Calculation

Order Number	Line Number	Order Type Priority	Order Type Priority Weight	Line Type Priority	Line Type Priority Weight	Requested Date Priority	Requested Date Priority Weight	Customer Priority	Customer Priority Weight
12637	1.000	100	5.00%	100	10.00%	150	50.00%	100	35.00%
12637	2.000	100	5.00%	110	10.00%	150	50.00%	100	35.00%
12638	1.000	100	5.00%	100	10.00%	100	50.00%	100	35.00%
12638	2.000	100	5.00%	110	10.00%	100	50.00%	100	35.00%

Order Number	Line Number	Order Type Segment Total	Line Type Segment Total	Requested Date Segment Total	Customer Segment Total	Total Score (Sum of Segment Totals)
12637	1.000	5	10	75	35	125
12637	2.000	5	11	75	35	126
12638	1.000	5	10	50	35	100
12638	2.000	5	11	50	35	101



# 10 Appendix B - Scenarios for Shipment Consolidation Mode

## Scenario 1: Multiple Order Consolidation Mode

When you process sales order lines through the JD Edwards EnterpriseOne Transportation Management system, the system assigns shipment numbers to the order lines based on the shipment consolidation mode that you select. The Transportation Management system offers four shipment consolidation modes:

- Multiple Order Consolidation
- Single Order Consolidation
- Transactional Consolidation
- No Consolidation

See *"Setting Up Transportation Constants " in the JD Edwards EnterpriseOne Applications Transportation Management Implementation Guide .*

The shipment consolidation mode affects how the system assigns shipment numbers when releasing order lines from fulfillment. This appendix discusses a scenario for each shipment consolidation mode and how the system assigns shipment numbers to released order lines and unreleased order lines.

In the Multiple Order Consolidation mode, the system consolidates order lines from multiple orders to a single shipment.

In this scenario, we have three orders for customer 4242. Because of multiple order consolidation, the system assigns the same shipment number to each order line of every order for customer 4242.

The original shipment number (802) consists of three orders and a total of seven order lines. This table illustrates the details of the original shipment number before running the Release from Fulfillment report (R4277703):

Order Number	Item	Quantity	Shipment Number
1	A	20	802
1	B	40	802
2	C	35	802
2	D	50	802
3	E	20	802
3	F	25	802

Order Number	Item	Quantity	Shipment Number
3	G	40	802

When you run the Release from Fulfillment report the system:

- Releases all quantity for Order 1
- Partially releases quantity for Order 2
- Does not release any quantity for Order 3

The following tables illustrate the results of fulfillment processing in the Multiple Order Consolidation mode:

Order Line	Item	Original Quantity	Original Shipment Number	Released Quantity	Unreleased Quantity	New Shipment Number
1	A	20	802	20	0	N/A
2	B	40	802	40	0	N/A

Order Line	Item	Original Quantity	Original Shipment Number	Released Quantity	Unreleased Quantity	New Shipment Number
1	C	35	802	35	0	N/A
2	D	50	802	35	15	803

Order Line	Item	Original Quantity	Original Shipment Number	Released Quantity	Unreleased Quantity	New Shipment Number
1	E	20	802	0	20	N/A
2	F	25	802	0	25	N/A
3	G	40	802	0	40	

The released quantities for each order line remain on the original shipment number (802). The system assigns a new shipment number (803) to all unreleased order lines. The following tables illustrate the contents of the original shipment number and the new shipment number after you run the Release from Fulfillment report:



Order Number	Item	Quantity
1	A	20
1	B	40
2	C	35
2	D	35

Order Number	Item	Quantity
2	D	15
3	E	15
3	F	25
3	G	40

## Scenario 2: Single Order Consolidation Mode

In the Single Order Consolidation mode, the system consolidates all of the order lines on a single order to one shipment.

In this scenario, we have a single order with five order lines. Because of single order consolidation, the system assigns the same shipment number to each order line.

The original shipment number (1001) consists of all the order lines on the sales order. The following table illustrates the details of the original shipment number before running the Release from Fulfillment report:

Order Line	Item	Quantity	Shipment Number
1	A	20	1001
2	B	15	1001
3	C	40	1001
4	D	50	1001

Order Line	Item	Quantity	Shipment Number
5	E	20	1001

When you run the Release from Fulfillment report, the system:

- Releases all quantity for order lines 1 and 2
- Partially releases quantity for order lines 3 and 4
- Does not release any quantity for order line 5

The following table illustrate the results of fulfillment processing in the Single Order Consolidation mode:

Order Line	Item	Original Quantity	Original Shipment Number	Released Quantity	Unreleased Quantity	New Shipment Number
1	A	20	1001	20	0	N/A
2	B	15	1001	15	0	N/A
3	C	40	1001	25	15	1002
4	D	50	1001	45	5	1002
5	E	20	1001	0	20	1002

The released quantities for each order line remain on the original shipment number (1001). The system assigns a new shipment number (1002) to all unreleased order lines. The following tables illustrate the contents of the original shipment number and the new shipment number after you run the Release from Fulfillment report:

Item	Quantity
A	20
B	15
C	25
D	45

Item	Quantity
C	15

Item	Quantity
D	5
E	20

## Scenario 3: Transactional Consolidation Mode

In the Transactional Consolidation mode, the system consolidates order lines that are entered or modified together onto the same shipment.

In this scenario, we have an order where we use the Add mode to enter four order lines. Later, we use the Update mode to add four additional order lines. Because of transactional consolidation, the system assigns a shipment number to each transaction related to the order.

The original shipment number for the Add mode (202) consists of the four order lines that you entered to initiate the sales order. The original shipment number for the Update mode (203) consists of the four order lines that you added to the sales order as a second transaction. The following tables illustrate the details of the original shipment numbers for the Add mode and the Update mode before running the Release from Fulfillment report:

Order Line	Item	Quantity	Shipment Number
1	A	10	202
2	B	20	202
3	C	40	202
4	D	50	202

Order Line	Item	Quantity	Shipment Number
5	E	10	203
6	F	20	203
7	G	40	203
8	H	50	203

When you run the Release from fulfillment report, the system:

- Releases all quantity for order lines 1 through 3
- Partially releases quantity for order lines 4 through 6
- Does not release any quantity for order lines 7 and 8

The following table illustrates the results of fulfillment processing in the Transactional Consolidation mode:

Order Line	Item	Original Quantity	Original Shipment Number	Released Quantity	Unreleased Quantity	New Shipment Number
1	A	10	202	10	0	N/A
2	B	20	202	20	0	N/A
3	C	40	202	40	0	N/A
4	D	50	202	30	20	204
5	E	10	203	5	5	205
6	F	20	203	15	5	206
7	G	40	203	0	40	207
8	H	50	203	0	50	207

The released quantities for each transaction remain on the original shipment number for the respective mode (202 or 203).

For the Add mode transaction, the system fully releases the quantity for order lines (1-3) and partially releases the quantity for order line 4. The released quantity remains on the Add mode original shipment number (202) and the system creates a new shipment number (204) for the partially unreleased quantity for item D.

For the Update mode transaction, the system partially releases the quantity for order lines 5 and 7. The released quantity remains on the original shipment number (203) and the system creates new shipment numbers (205 and 206) for each partially unreleased order line. The system does not release any quantity for order lines 7 and 8. Because the system did not release any quantity for either order line, the system assigns the quantity for each order line to the same shipment number (207).

The following tables illustrate the contents of the original shipment numbers and the new shipment numbers after you run the Release from Fulfillment report:

Shipment Number	Item	Quantity
202	A	10

Shipment Number	Item	Quantity
202	B	20
202	C	40
202	D	30
203	E	5
203	F	15

Shipment Number	Item	Quantity
204	D	20
205	E	5
206	F	5
207	G	40
207	H	50

## Scenario 4: No Consolidation Mode

In the No Consolidation mode, the system assigns a shipment number to each order line of a sales order.

In this scenario, we have a sales order with four order lines. Because of no consolidation, when we create the sales order, the system assigns a different shipment number to each order line.

The original shipment numbers are 400, 401, 402, and 403. The following table illustrates the details of the sales order lines and each respective original shipment number before running the Release from Fulfillment report:

Order Line	Item	Quantity	Shipment Number
1	A	50	400
2	B	75	401

Order Line	Item	Quantity	Shipment Number
3	C	100	402
4	D	150	403

When you run the Release from Fulfillment report, the system:

- Partially releases the quantity for order lines 1, 3, and 4
- Releases all of the quantity for order line 2

This table illustrates the results of fulfillment processing in the No Consolidation mode:

Order Line	Item	Original Quantity	Original Shipment Number	Released Quantity	Unreleased Quantity	New Shipment Number
1	A	50	400	25	25	404
2	B	75	401	75	0	N/A
3	C	100	402	80	20	405
4	D	150	403	100	50	406

The released quantities for each order line remain on their respective original shipment number. The system assigns a new shipment number to the partially released order lines. The system does not create a new shipment number for order line 2 because the system did not release any of the order lines from fulfillment. The following tables illustrate the contents of the original shipment numbers after you run the Release from Fulfillment report:

Shipment Number	Item	Quantity
400	A	25
401	B	75
402	C	20
403	D	50

Shipment Number	Item	Quantity
404	A	25
405	C	80
406	D	100





# Index

## A

- Advanced Preference Detail Revisions program (P4072) [18](#)
- Advanced preferences
  - definitions [20](#)
  - details
    - setting up [21](#)
  - driver fields [14](#)
  - overview [17](#)
  - processing [18](#)
  - return fields [14](#)
  - schedules
    - setting up [20](#)
- Advanced Preferences Name Revisions program (P4071) [18](#)
- Advanced Preferences Schedule Revisions program (P4070) [18](#), [38](#), [55](#), [108](#)
- Auto Fulfillment Load Balance program (R4277711) [80](#), [80](#), [81](#), [92](#), [92](#)
  - processing options [92](#)
  - running the program [92](#)
- Auto fulfillment processing [79](#)
- Auto Fulfillment Processing program (R4277701) [2](#), [27](#), [58](#), [60](#), [79](#), [81](#), [81](#), [81](#), [81](#), [81](#), [92](#), [92](#), [92](#)
  - processing options [90](#)

## B

- Basic Fulfillment Scoring Setup table (F4277750) [42](#), [51](#), [53](#), [55](#)
- Basic Score Setup program (P4277750) [49](#)

## C

- Customer Master program (P03013) [42](#)
- Customer priority [42](#)
  - setting up [43](#)

## D

- Default Location/Printers table (F40095) [97](#)

## E

- EnterpriseOne System Control program (P99410) [15](#)

## F

- F40095 table [97](#)
- F40711 table [13](#), [14](#)
- F4211 table [14](#), [21](#), [84](#)
- f4277701 table [105](#)
- F4277701 table [57](#), [69](#), [69](#), [71](#), [72](#), [105](#)
- F4277710 table [90](#)
- F4277711 table [57](#), [68](#), [69](#), [71](#), [72](#), [105](#), [105](#)
- F4277750 table [42](#), [51](#), [53](#), [55](#)
- F99410 table [13](#), [14](#)
- Fulfillment Entry Batch Processing program (R4277704) [21](#), [25](#), [25](#), [67](#)
  - processing options [40](#)
  - running the program [40](#)
- Fulfillment Management Setup program (R4277706) [14](#), [14](#)
  - inserting setup data [13](#)
  - running the program [16](#)
- Fulfillment Plan ID table (F4277710) [90](#)

## Fulfillment processing

- batch entry [25](#)
- Demand Scheduling Execution [29](#)
- Inventory Management [26](#)
- Oracle Transportation Management [35](#)
- Transportation Management [31](#)
- Warehouse Management [33](#)

## Fulfillment rounding

- overview [87](#)
- setting up [89](#)

## Fulfillment rules

- overview [83](#)
- scenario [83](#)
- setting up [86](#)

## Fulfillment Rules program (P4277720) [83](#), [91](#)

## Fulfillment Workbench

- overview [95](#)

## Fulfillment Workbench — Edit form [101](#)

- Fulfillment Workbench program (P4277701) [27](#), [27](#), [28](#), [31](#), [35](#), [57](#), [58](#), [60](#), [67](#), [69](#), [95](#), [95](#), [95](#)
  - Edit form [101](#)
  - processing options [96](#)
  - Search form [99](#)

## J

### JD Edwards EnterpriseOne Fulfillment Management

- benefits [2](#)
- business process [3](#)
- implementation [8](#)
- implementation steps
  - application-specific [11](#)
  - global [9](#)
  - sales-specific [10](#)
- integrations
  - overview [5](#)
- product overview [1](#)
- system activation [13](#)

## O

- OneWorld System Control File table (F99410) [13](#), [14](#)

## P

- P03013 program [42](#)
- P4070 program [18](#), [38](#), [55](#), [108](#)
- P4071 program [18](#), [18](#), [21](#)
- P4072 program [18](#)
- P4205 program [97](#)
- P4210 program [17](#), [18](#), [35](#), [57](#), [60](#), [69](#), [75](#)
  - processing options [36](#)
- P4277701 program [27](#), [27](#), [28](#), [31](#), [35](#), [57](#), [58](#), [60](#), [67](#), [69](#), [95](#), [95](#), [95](#)
  - Edit form [101](#)
  - processing options [96](#)
  - Search form [99](#)
- P4277711 program [75](#)
- P4277720 program [83](#), [91](#)
- P4277750 program [49](#)
- P4277760 program [57](#), [61](#)
- P99410 program [15](#)

Preference Definition program (P4071) [21](#)  
 Preference detail values  
   setting up Fulfillment Entry (41) [21](#)  
   setting up Line Type Priority (43) [47](#)  
   setting up Order Type Priority (42) [46](#)  
   setting up Requested Date Age Priority (44) [48](#)  
 Preference Values Definition table (F40711) [13](#), [14](#)  
 Price Adjustment Type program (P4071) [18](#)

  setting up [63](#)  
 Service Level Rules Inquiry/Override program (P4277711) [75](#)  
 Service Level Rules Maintenance program (P4277760) [61](#)  
 Service Level Rules Update program (R4277705) [37](#), [67](#), [73](#)  
   processing options [74](#)  
 Shipment Confirmation program (P4205) [97](#)

## R

R4277701 program [2](#), [27](#), [58](#), [60](#), [79](#), [81](#), [81](#), [81](#), [81](#), [81](#), [81](#), [81](#), [92](#), [92](#), [92](#)  
   processing options [90](#)  
 R4277702 program [37](#), [41](#), [53](#)  
   processing options [53](#)  
   running the program [53](#)  
 R4277703 program [25](#), [57](#), [58](#), [61](#), [65](#), [65](#), [91](#), [105](#), [108](#)  
   processing options [107](#)  
   running the program [107](#)  
 R4277704 program [21](#), [25](#), [25](#), [67](#)  
   processing options [40](#)  
   running the program [40](#)  
 R4277705 program [37](#), [67](#), [73](#)  
   processing options [74](#)  
 R4277706 program [14](#), [14](#)  
   inserting setup data [13](#)  
   running the program [16](#)  
 R4277711 program [80](#), [80](#), [81](#), [92](#), [92](#)  
   processing options [92](#)  
   running the program [92](#)  
 Release From Fulfillment program (R4277703) [25](#), [57](#), [58](#), [61](#), [65](#), [65](#), [91](#),  
   [105](#), [108](#)  
   processing options [107](#)  
   running the program [107](#)

## S

Sales Order Detail table (F4211) [14](#), [21](#), [84](#)  
 Sales Order Entry program (P4210) [17](#), [18](#), [35](#), [57](#), [60](#), [69](#), [75](#)  
   processing options [36](#)  
 Sales Order Score Batch Processing program (R4277702) [37](#), [41](#), [53](#)  
   processing options [53](#)  
   running the program [53](#)  
 Scoring  
   advanced preference [43](#)  
   basic  
     overview [49](#)  
     setting up [51](#)  
   overview [41](#)  
   scenario [43](#)  
 Service Level Evaluation Required flag [70](#)  
 Service Level Rule Detail table (F4277711) [57](#), [68](#), [69](#), [71](#), [105](#), [105](#)  
 Service Level Rule Detail table (F4277711) [72](#)  
 Service Level Rule Header table (F4277701) [69](#), [69](#), [71](#), [72](#)  
 Service Level Rule program (P4277760) [57](#)  
 Service Level Rule table (F4277701) [57](#), [105](#), [105](#)  
 Service Level Rules  
   dynamic overrides [69](#)  
   line custom function rules [62](#)  
   order custom function rules [62](#)  
   override processing [68](#)  
   overriding [75](#), [76](#)  
   overview [57](#)  
   processing [70](#)  
   requested order quantity update [69](#)  
   resolution [68](#)