

Oracle Talari T3010/T5000

Hardware Guide



Original Publication Date: Nov 1, 2019



Copyright © 2019, 2007 Oracle and/or its affiliates. All rights reserved.

This software and related documentation are provided under a license agreement containing restrictions on use and disclosure and are protected by intellectual property laws. Except as expressly permitted in your license agreement or allowed by law, you may not use, copy, reproduce, translate, broadcast, modify, license, transmit, distribute, exhibit, perform, publish, or display any part, in any form, or by any means. Reverse engineering, disassembly, or decompilation of this software, unless required by law for interoperability, is prohibited.

The information contained herein is subject to change without notice and is not warranted to be error-free. If you find any errors, please report them to us in writing.

If this is software or related documentation that is delivered to the U.S. Government or anyone licensing it on behalf of the U.S. Government, the following notice is applicable:

U.S. GOVERNMENT END USERS: Oracle programs, including any operating system, integrated software, any programs installed on the hardware, and/or documentation, delivered to U.S. Government end users are "commercial computer software" pursuant to the applicable Federal Acquisition Regulation and agency-specific supplemental regulations. As such, use, duplication, disclosure, modification, and adaptation of the programs, including any operating system, integrated software, any programs installed on the hardware, and/or documentation, shall be subject to license terms and license restrictions applicable to the programs. No other rights are granted to the U.S. Government.

This software or hardware is developed for general use in a variety of information management applications. It is not developed or intended for use in any inherently dangerous applications, including applications that may create a risk of personal injury. If you use this software or hardware in dangerous applications, then you shall be responsible to take all appropriate fail-safe, backup, redundancy, and other measures to ensure its safe use. Oracle Corporation and its affiliates disclaim any liability for any damages caused by use of this software or hardware in dangerous applications.

Oracle and Java are registered trademarks of Oracle and/or its affiliates. Other names may be trademarks of their respective owners.

Intel and Intel Xeon are trademarks or registered trademarks of Intel Corporation. All SPARC trademarks are used under license and are trademarks or registered trademarks of SPARC International, Inc. AMD, Opteron, the AMD logo, and the AMD Opteron logo are trademarks or registered trademarks of Advanced Micro Devices. UNIX is a registered trademark of The Open Group. Windows® 7 and Windows® XP are trademarks or registered trademarks of Microsoft Corporation.

This software or hardware and documentation may provide access to or information on content, products, and services from third parties. Oracle Corporation and its affiliates are not responsible for and expressly disclaim all warranties of any kind with respect to third-party content, products, and services. Oracle Corporation and its affiliates will not be responsible for any loss, costs, or damages incurred due to your access to or use of third-party content, products, or services, except as set forth in an applicable agreement between you and Oracle.

Table of Contents

Table of Contents	3
About This Document	4
Audience	4
Reference Documents	4
Hardware and Software Requirements	5
About the Oracle Talari Appliance	6
Oracle SD-WAN Overview	6
Front Panel Configuration	6
Rear Panel Configuration	7
Ethernet Ports	7
NIC Indicator Codes	8
LAN/WAN Port Connectivity	9
Untrusted Interfaces	9
Hardware Specifications	10
Installing the Talari Appliance	11
Rack Installation	11
Installing the Rack Mount Brackets and Rails	11
Separate the Inner and Outer Rails	11
Attaching Inner Rails	13
Attaching Outer Rails to the Rack	14
Adding Your T3010/T5000 to the Rack	15
LAN/WAN Connections	15
Connecting Power to the Appliance	15
Important Note about Cabling and Bypass Mode	16
Powering Up the Appliance	16
Checklist for Power Up	16
Configuring the APN Appliance	16
Troubleshooting	17
Basic Troubleshooting	17
Appliance Troubleshooting Basics	17
Troubleshooting Bypass Mode (Fail-to-Wire)	18

About This Document

This guide describes the physical characteristics of the Oracle Talari Appliance T3010 and Oracle Talari Appliance T5000. It includes instructions for setting up the physical connections on the front and back panels and for mounting these appliances in a rack.

My Oracle Support

My Oracle Support (<https://support.oracle.com>) is your initial point of contact for all product support and training needs. A representative at Customer Access Support (CAS) can assist you with My Oracle Support registration.

Call the CAS main number at 1-800-223-1711 (toll-free in the US), or call the Oracle Support hotline for your local country from the list at <http://www.oracle.com/us/support/contact/index.html>. When calling, make the selections in the sequence shown below on the Support telephone menu:

1. Select 2 for New Service Request.
2. Select 3 for Hardware, Networking, and Solaris Operating System Support.
3. Select one of the following options:

- For technical issues such as creating a new Service Request (SR), select 1.
- For non-technical issues such as registration or assistance with My Oracle Support, select 2.

You are connected to a live agent who can assist you with My Oracle Support registration and opening a support ticket.

My Oracle Support is available 24 hours a day, 7 days a week, 365 days a year.

Emergency Response

In the event of a critical service situation, emergency response is offered by the Customer Access Support (CAS) main number at 1-800-223-1711 (toll-free in the US), or call the Oracle Support hotline for your local country from the list at <http://www.oracle.com/us/support/contact/index.html>. The emergency response provides immediate coverage, automatic escalation, and other features to ensure that the critical situation is resolved as rapidly as possible.

A critical situation is defined as a problem with the installed equipment that severely affects service, traffic, or maintenance capabilities, and requires immediate corrective action. Critical situations affect service and/or system operation resulting in one or several of these situations:

- A total system failure that results in loss of all transaction processing capability
- Significant reduction in system capacity or traffic handling capability

- Loss of the system's ability to perform automatic system reconfiguration
- Inability to restart a processor or the system
- Corruption of system databases that requires service affecting corrective actions
- Loss of access for maintenance or recovery operations
- Loss of the system ability to provide any required critical or major trouble notification

Any other problem severely affecting service, capacity/traffic, billing, and maintenance capabilities may be defined as critical by prior discussion and agreement with Oracle.

Locate Product Documentation on the Oracle Help Center Site

Oracle Communications customer documentation is available on the web at the Oracle Help Center (OHC) site, <http://docs.oracle.com>. You do not have to register to access these documents. Viewing these files requires Adobe Acrobat Reader, which can be downloaded at <http://www.adobe.com>.

1. Access the Oracle Help Center site at <http://docs.oracle.com>.
2. Click Industries.
3. Click the Oracle Communications link.

Under the SD-WAN header, select a product.

4. Select the Release Number.

A list of the entire documentation set for the selected product and release appears.

5. To download a file to your location, right-click the PDF link, select Save target as (or similar command based on your browser), and save to a local folder.

Reference Documents

The following documents are available:

- *Talari Appliance T3010/5000 Getting Started Guide*
- *Talari Glossary*
- *Talari APN Appliance Quick Start Guide*
- *Talari APN Implementation Guide*
- *Talari APN Software Configuration File Reference* (available for each major/minor release)
- *Talari APN Software Release Notes* (available for each release)

Hardware and Software Requirements

The T3010 and T5000 have the following hardware and software requirements:

Hardware:

The appliances must be mounted in a standard, 19-inch (480mm), four-post rack.

Software:

The Talari Adaptive Private Networking (APN) Software, which comes pre-installed on all Talari Appliances, supports current versions of the following Web browsers with cookies and JavaScript enabled:

- Microsoft IE9 – IE11
- Mozilla Firefox
- Google Chrome

Display:

A minimum screen resolution of 1024 x 960 or greater is recommended.

About the Oracle Talari Appliance

Designed to bring network reliability and increased capacity to enterprise offices and data centers, the 2U rack-mountable T3010 delivers up to 500 Mbps across eight WAN Links and connects up to 128 sites.

The 2U rack-mountable T5000 serves the same purpose for large data centers and call centers, delivering up to 3Gbps across eight WAN Links and connecting up to 256 sites.

Oracle SD-WAN Overview

Talari redefined WAN reliability and application performance with its family of Oracle Talari Appliances. By adding Oracle Talari Appliances to existing networks, customers can aggregate and transform affordable broadband connections to deliver enterprise class performance and reliability at consumer prices. A Talari WAN delivers more bandwidth, reduces WAN operating expenses, and provides greater reliability than any existing single-provider WAN.

Using our patented Adaptive Private Networking (APN) technology, Talari’s solution combines disparate, abundant, affordable IP bandwidth sources, and provides reliable, resilient, high-quality connectivity between sites, ensuring application and business continuity. Oracle Talari Appliances deployed at headquarters and remote offices create a network of Conduits. Each Conduit is made up of multiple WAN Links, and data transmitted across the Conduits is optimized to use network resources available across all WAN Links.

Front Panel Configuration

The T3010 and T5000 front panels incorporate a Liquid Crystal Display (LCD) module with a keypad used to power the unit on and off.

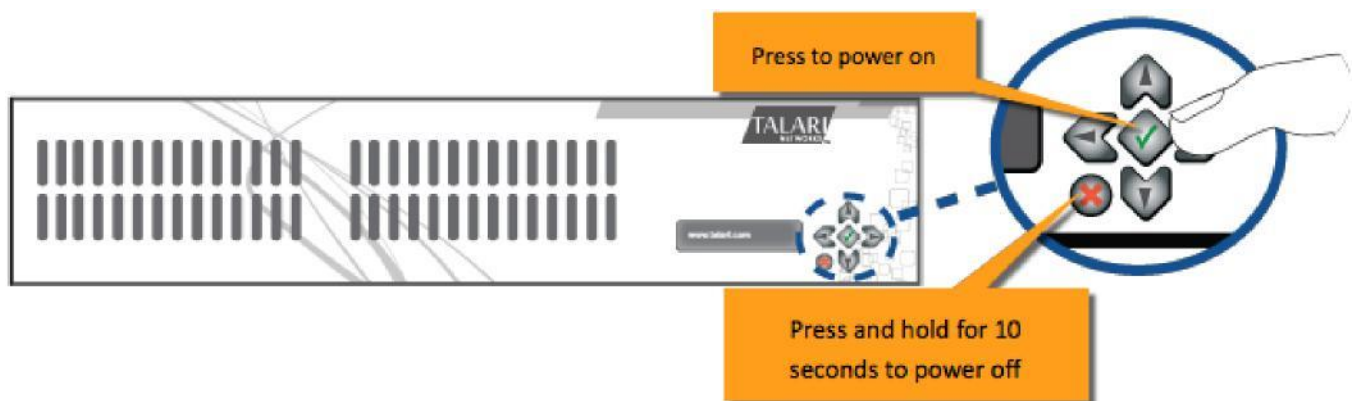

Figure 1: T3010 and T5000 Front Panel Configuration

Please note that the LCD keypad’s arrow keys are reserved for future use.

Rear Panel Configuration

The T3010 and T5000 rear panels contain the following user interface ports:

- A VGA monitor port
- Four USB 2.0 ports
- One DB9 console port
- One management port
- One auxiliary port (limited to 100 Mbps full duplex)
- A dual, hot-swappable AC power supply
- T3010: One quad port Gigabit Ethernet bypass server adapter card
- T5000: Two quad port Gigabit Ethernet bypass server adapter cards

Note: Running the T3010 or T5000 with a single power supply is not recommended for standard operation. Connect power to both power supplies when installing these devices.

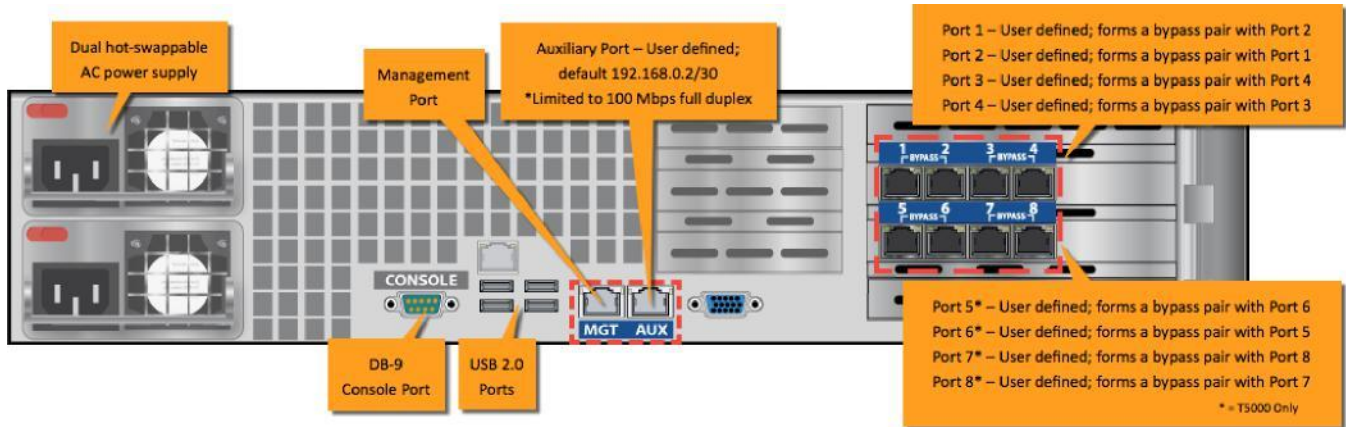

Figure 2: T5000 Rear Panel Configuration

Ethernet Ports

On the T3010, ports 1 and 2 form a bypass pair while ports 3 and 4 form a second bypass pair. On the T5000, as illustrated in Figure 2, the second quad port Gigabit Ethernet bypass server adapter card is equipped with four additional ports. On the T5000's second Ethernet adapter card, ports 5 and 6 form a bypass pair while ports 7 and 8 form another bypass pair.

Port	Description
MGT	Management port (dedicated – out of band)
1	User defined; forms a Bypass pair with Port 2
2	User defined; forms a Bypass pair with Port 1
3	User defined; forms a Bypass pair with Port 4
4	User defined; forms a Bypass pair with Port 3
5	User defined; forms a Bypass pair with Port 6 (T5000 only)
6	User defined; forms a Bypass pair with Port 5 (T5000 only)
7	User defined; forms a Bypass pair with Port 8 (T5000 only)
8	User defined; forms a Bypass pair with Port 7 (T5000 only)
AUX	User defined; Used for MGT AUX. May be used as an untrusted port

Table 1: Ethernet Ports

NIC Indicator Codes

Ethernet ports on the rear panel have indicator lights for information on network activity and link status.

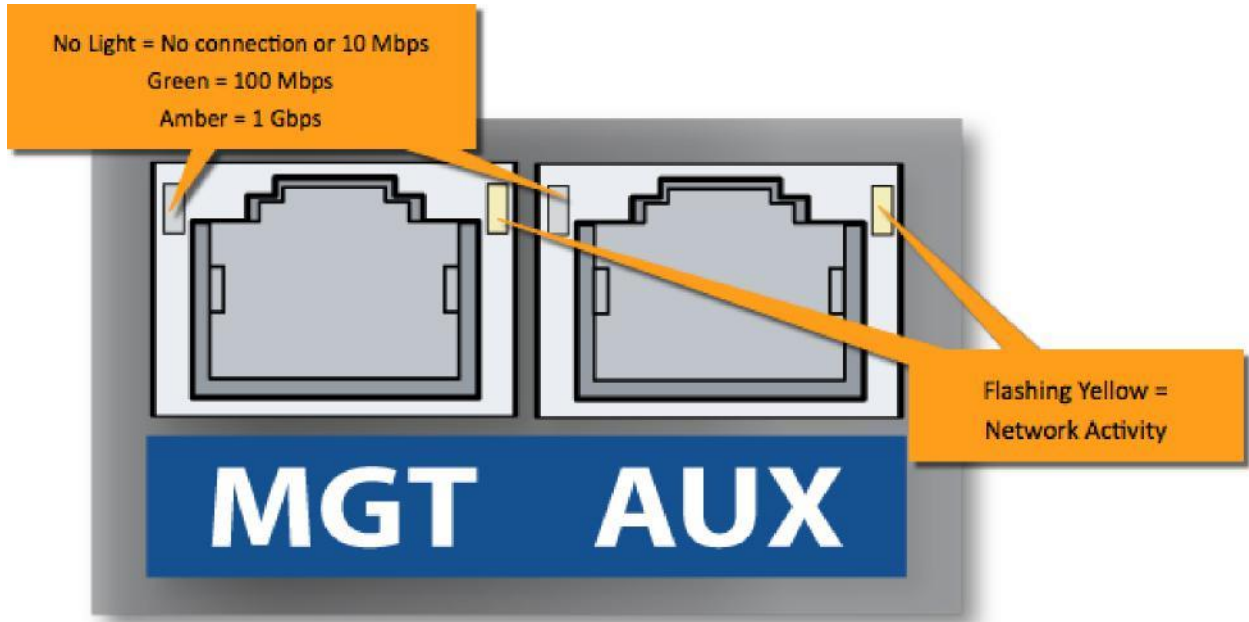

Figure 3: Management Interfaces

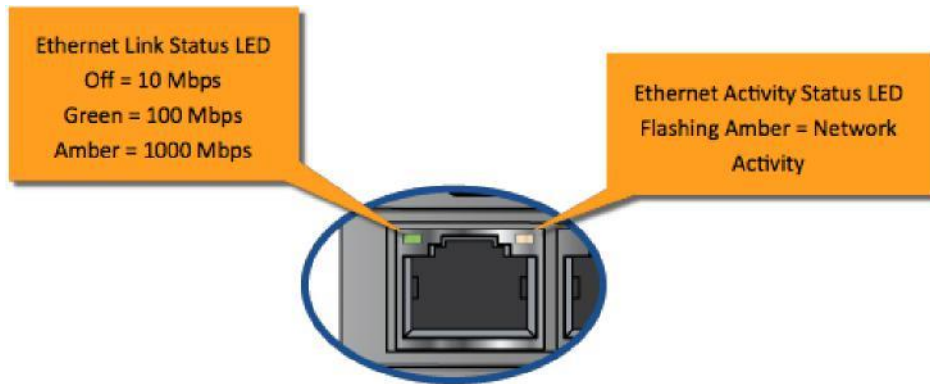

Figure 4: Bypass Interfaces

LAN/WAN Port Connectivity

Connect a configured Ethernet LAN port to the LAN side of your network. Connect the corresponding configured WAN port to the WAN side of your network. As illustrated in [Figure 5](#), port 1 corresponds to port 2, while port 3 corresponds to port 4. For the T5000, port 5 corresponds to port 6, and port 7 corresponds to port 8.

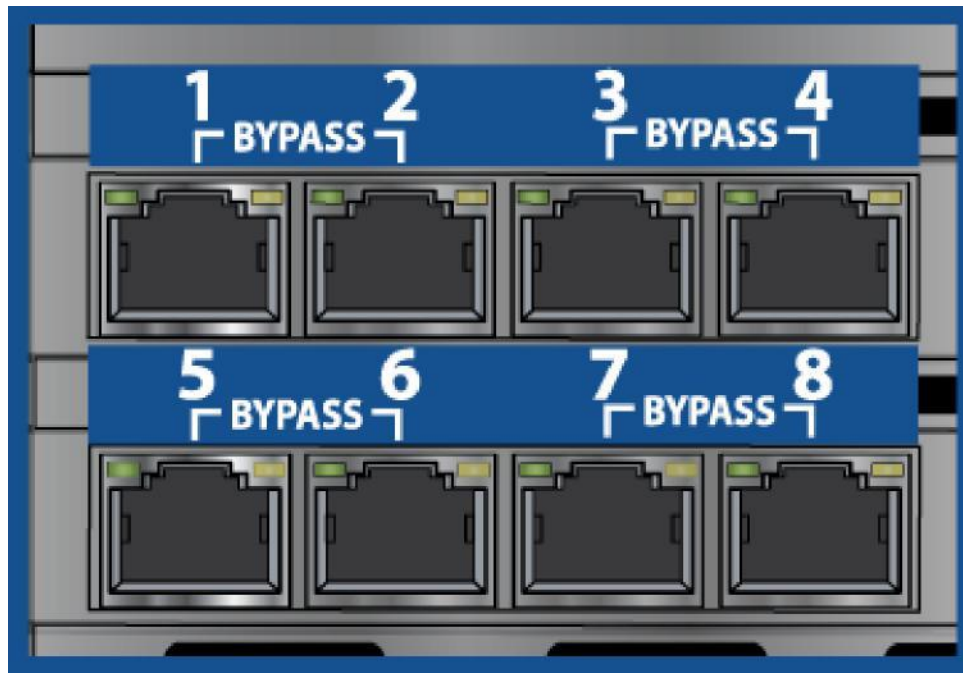

Figure 5: LAN/WAN Ports and Bypass Pairs

The aforementioned port pairs can operate in bypass mode. This bypass capability allows the appliance to forward Ethernet frames between the bypass port pairs in the event of power loss or if the Talari Service is disabled.

The T3010 and T5000 ship with the assigned, default IP address of 192.168.0.2/30. The appliance is accessible via the Management Auxiliary (AUX) port using the default IP address until the management IP address is changed via the web console. Follow the instructions in the *Talari APN Appliance Quick Start Guide* to configure the appliance.

Untrusted Interfaces

Ethernet ports may be configured as untrusted interfaces. Untrusted interfaces connect to untrusted zones that the administrator does not want to place within the normal switched or routed enterprise network because of security or convenience. Non-Conduit traffic from the WAN to an untrusted interface is unable to communicate to any network point inside of the Talari WAN. For example, a user on the enterprise LAN cannot ping, or otherwise communicate with, any entity on the Ethernet domain attached to an untrusted interface through the Talari Appliance or vice-versa. An untrusted segment is entirely isolated from the rest of the network with the exception of the Talari WAN's own AES encrypted paths.

Hardware Specifications

The T3010 and T5000 have the following hardware specifications:

	Specification
Power	100-240 volts 50-60 Hz, 9-3.5 Amp Redundant 740W ATX AC power supply UL approved, FCC compliant
Physical Dimensions	EIA RS-310 standards 2U 437mm (W) x 648mm (D) x 89mm (H) (17.2" x 25.5" x 3.5")
Mounting Options	Rack mount Universal 2U rail kit (included)
Link LEDs	Link activity Link speed
LCD	Six button LCD
Operating Temperature	0 to 40° C (32 to 104° F)
Storage Temperature	-20 to 80° C (-4 to 176° F)
Relative Humidity	10% to 90% non-condensing
Capacity	T3010 - 6 Ethernet ports T5000 - 10 Ethernet ports
User Interfaces	4 USB 2.0 ports 1 VGA port 1 Serial Port (RS232, DB9) 2 Gigabit Ethernet ports on motherboard (one limited to 100 Mbps full duplex) T3010: 4 Gigabit Ethernet ports (with Bypass) T5000: 8 Gigabit Ethernet ports (with Bypass)
Mean Time Between Failure (MTBF)	T3010: 34,927 hours T5000: 31,092 hours

Table 2: Hardware Specifications

Installing the Talari Appliance

Rack Installation

Prior to installing the system in a rack, adhere to the following rack installation guidelines:

- Ensure that there is adequate airflow through the rack, because restricted airflow can lead to equipment damage.
- Leave at least 1U of vertical space between the systems you install in a rack.
- Ensure that the rack width and depth allows for proper serviceability and cable management.
- Ensure that the rack is properly secured to the floor or ceiling and is grounded.
- Load the rack from the bottom up.
- Load the heaviest component in the rack first.
- Ensure that the rack is level and stable before removing components.
- Do not move racks by yourself. At least two people are required to safely move racks and stage equipment.
- Ensure that cables are easily identifiable.

Installing the Rack Mount Brackets and Rails

The T3010 and T5000 both ship with a rack mounting kit included. These appliances require a four-post rack for safe installation. Additionally, the outer rails extend from 27 inches to 36.4 inches. Follow the steps below to install the rack-mount brackets.

Separate the Inner and Outer Rails

Separate the inner rail from the outer rail by pressing the locking tab on the inner rail. Please see [Figure 6](#).

1. Locate the rail assembly in the chassis packaging.

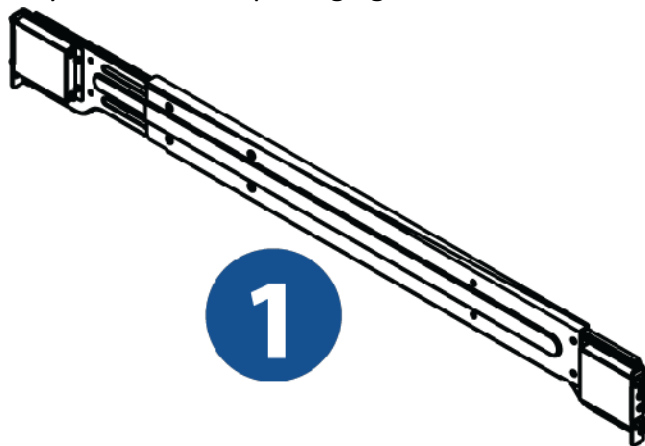

Figure 6: Rail Assembly

2. Extend the rail assembly by pulling it outward.

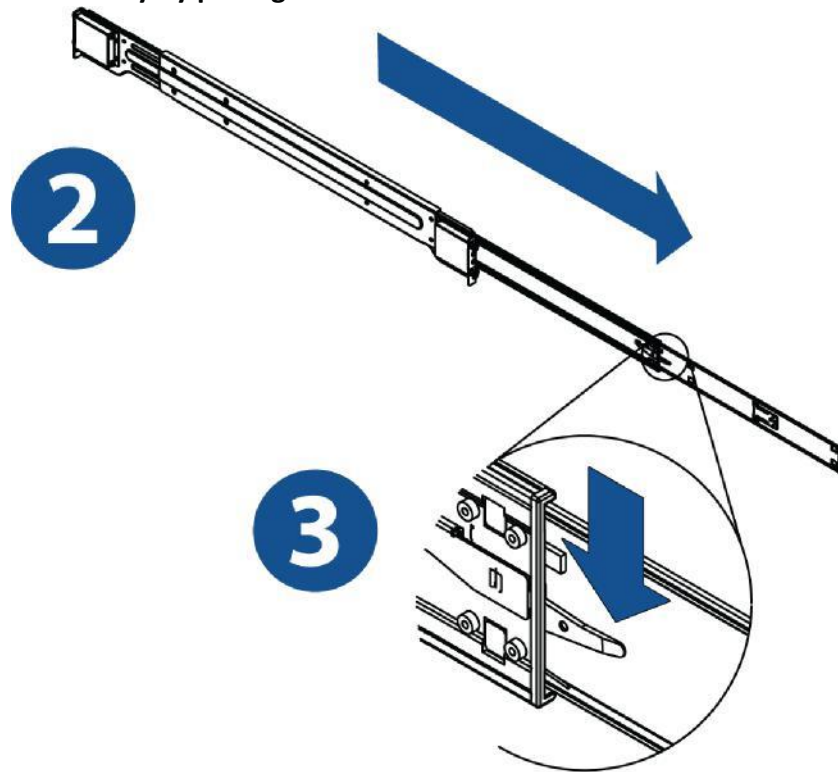

Figure 7: Extend Rail Assembly

- 3. Press the quick-release tab as illustrated in [Figure 7](#).
- 1. Separate the inner rail extension from the outer rail assembly.

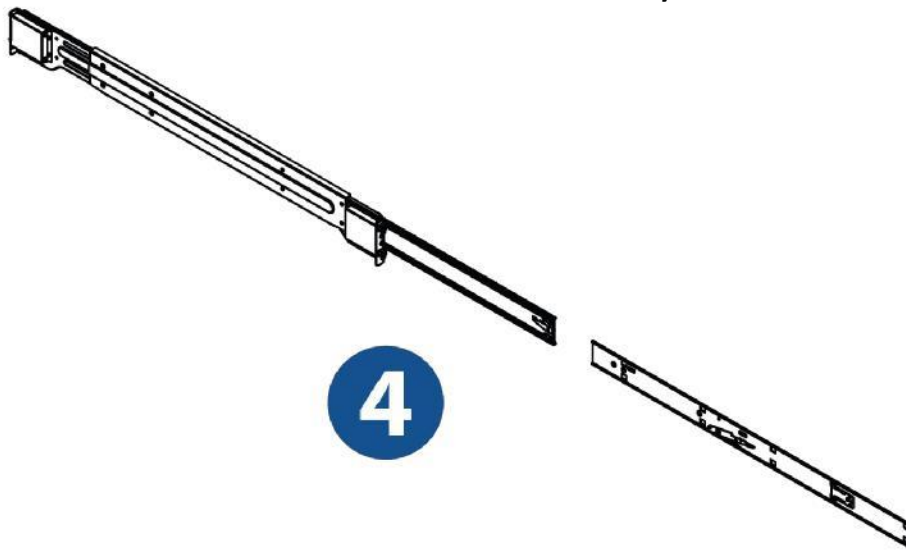

Figure 8: Separate Inner Rail Extension from Outer Rail

Attaching Inner Rails

1. Attach one inner rail to each side of the appliance by aligning the holes in the bracket with the corresponding hooks on the appliance.
2. Slide the rails into place on the appliance.
3. Secure the inner rail to the appliance using the screws provided.

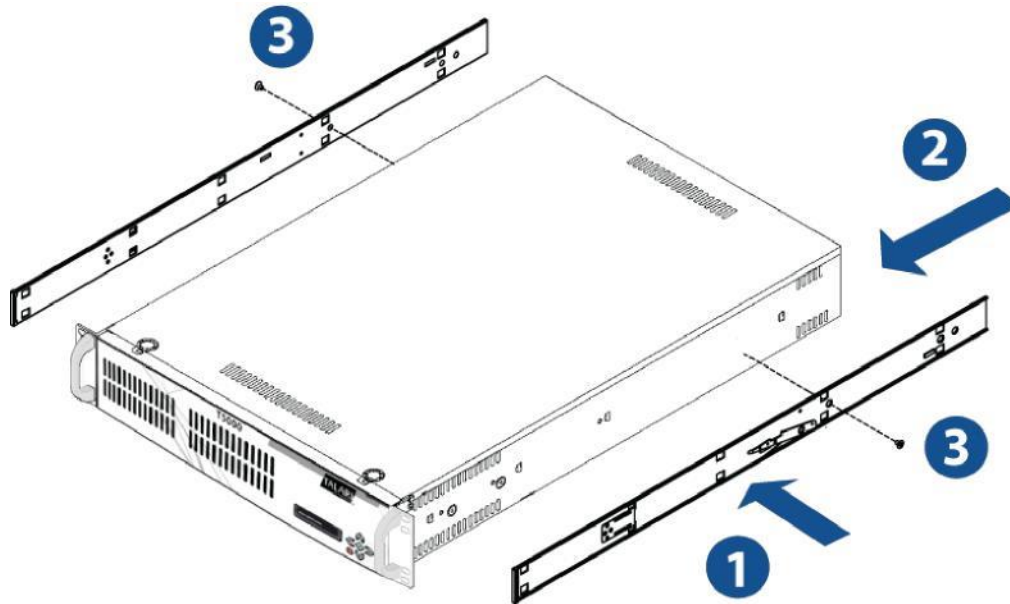

Figure 9: Secure Rails to the Appliance

Attaching Outer Rails to the Rack

4. Secure the back end of the outer rail to the rack by placing the hooks of the rails into the rack holes and securing the outer rail with the screws included in the rack mounting kit.
5. Press the button where the two outer rails are joined to retract the smaller outer rail as illustrated in [Figure 10](#) steps 1 and 2.
6. Secure the front end of the outer rail to the rack by hanging the hooks of the rails to the rack holes and securing with screws as illustrated in [Figure 10](#) step 3.

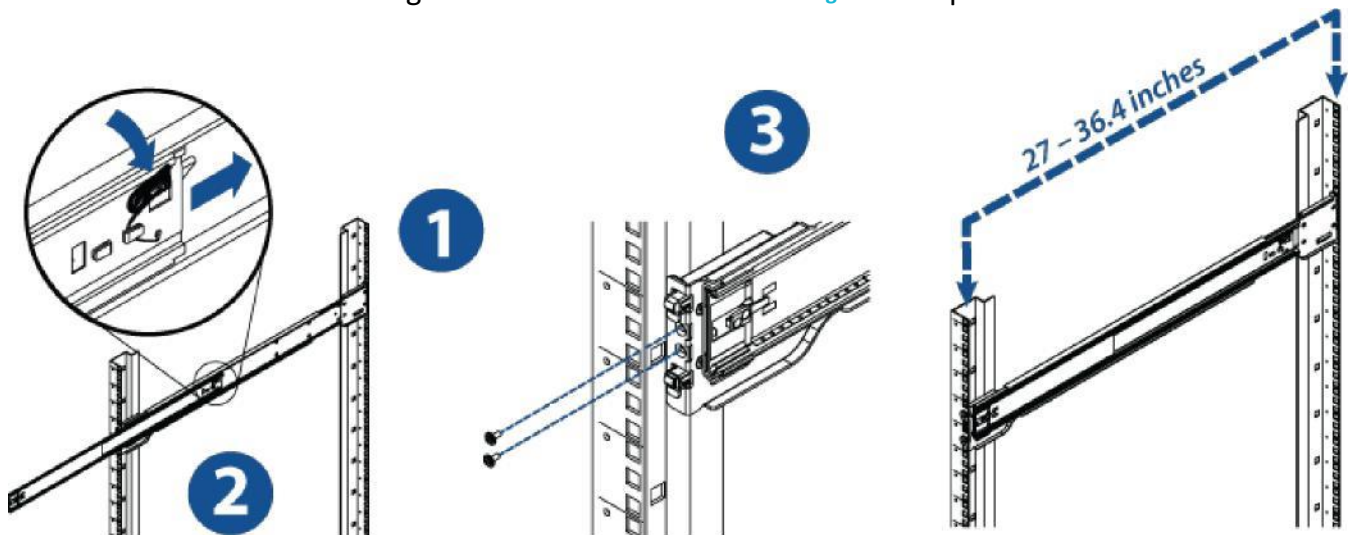

Figure 10: Attach Outer Rails to the Rack

Note: The T3010 and T5000 outer rails require a minimum of 27 inches for rack installation. The outer rails extend from 27 inches to 36.4 inches. Screw the handles into the outer rails for additional security if necessary.

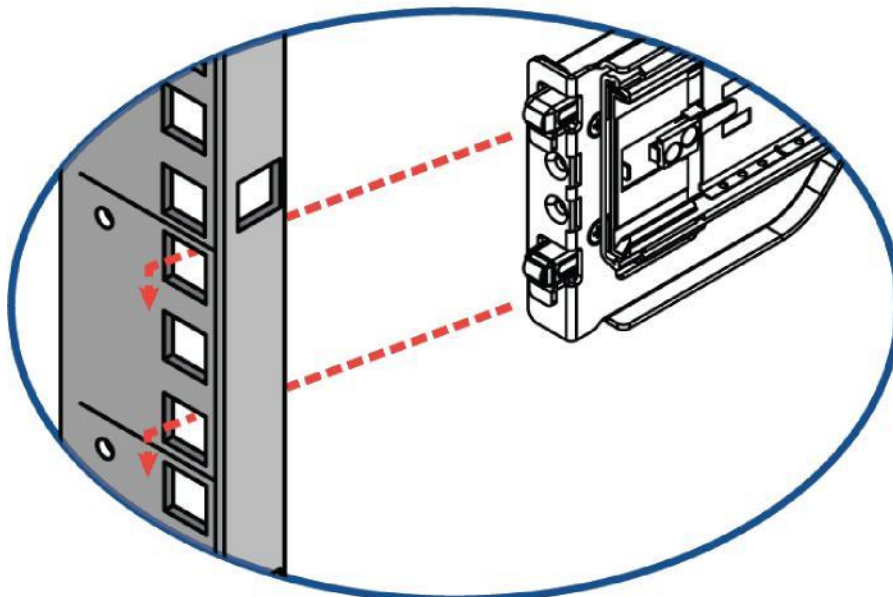

Figure 11: Attach Handles to Outer Rails

Adding Your T3010/T5000 to the Rack

1. Extend the outer rails as illustrated in [Figure 12](#).
2. Align the inner rails attached to the chassis with the outer rails attached to the rack.
3. Slide the inner rails into the outer rails and keep the pressure even on both sides, and push the chassis into the rack. When the chassis is pushed completely into the rack, it should click into the locked position.
4. Optional: Use the screws included in the mounting kit to secure the front of the chassis to the rack.

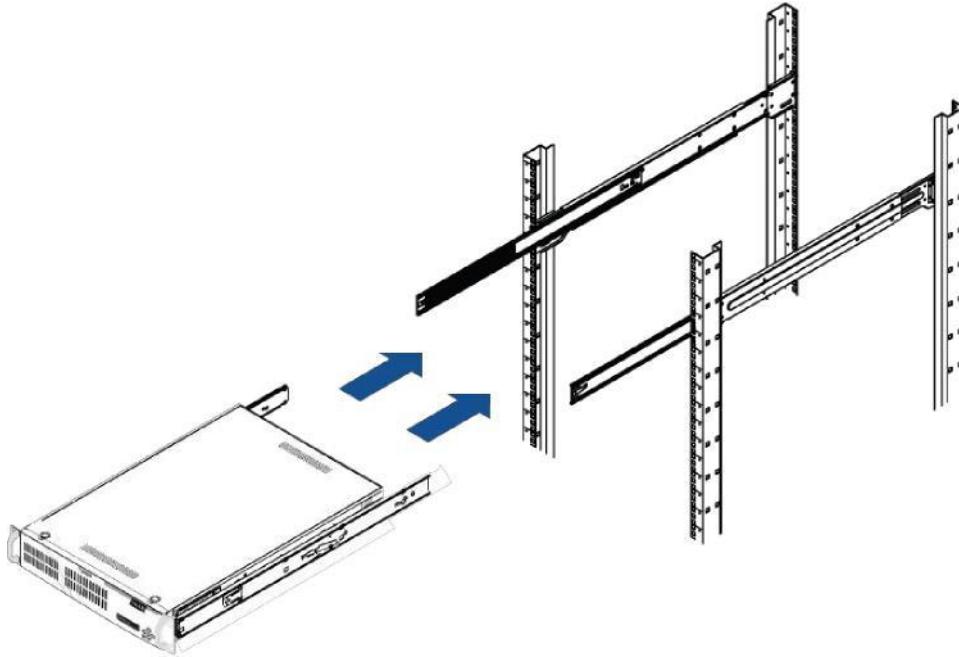

Figure 12: Slide APN Chassis into Rack Using Installed Rails

LAN/WAN Connections

When connecting each Ethernet (LAN or WAN) cable to the appropriate connector on the T3010 or T5000:

- Position the cables carefully so that they do not put strain on the connectors.
- Organize cables in bundles so that cables do not intertwine.
- Inspect the cables to make sure that the routing and bend radii are satisfactory. Reposition cables if necessary.
- Install cable ties in accordance with site requirements.

Connecting Power to the Appliance

When connecting power to the T3010 or T5000:

- Plug both AC power cords into the appliance.
- Plug both AC power cords into an uninterrupted AC power source.
- The appliance will start automatically.

Note: Running the T3010 or T5000 with a single power supply is not recommended for standard operation. Connect power to both power supplies when installing these devices.

The appliance power connectors are shown below. The T3010 and T5000 use 120/240 VAC.



Figure 13: Connect Power Cables to Appliance

Important Note about Cabling and Bypass Mode

When your Oracle Talari Appliance is operating in bypass mode (e.g., when it is powered off), the appliance acts like a crossover cable. This may cause a loss of the link between the appliance and older network devices that do not support Auto MDI-X when straight-through cables are used to connect the LAN and WAN ports of the APNA. In such a case, a crossover cable is required from the APNA WAN port to the older network device.

If your network devices support Auto MDI-X capability, the link should be automatically established when the device enters bypass mode and there should be no need for crossover cables. Talari recommends testing and verifying this capability with the appliance powered off.

For assistance, please contact the Talari Support team.

Powering Up the Appliance

Checklist for Power Up

Power up the T3010 or T5000 by performing the following steps:

5. Determine the IP address for the Ethernet management interface.
6. Confirm that the chassis is securely mounted.
7. Confirm that the power and Ethernet cables are connected.

The appliance powers up automatically when first plugged in.

If you encounter problems when you power up the appliance, please see the

Troubleshooting section of this document.

Configuring the APN Appliance

The T3010 and T5000 ship with a default management IP address of 192.168.0.2/30. In order to access your appliance remotely, you must first connect to it directly via the Management Auxiliary interface (AUX) and configure a management IP address for the appliance.



Figure 14: Configuring the Appliance

Use an Ethernet cable to connect from a PC to the interface labeled AUX, then refer to the *Talari Appliance T3010/T5000 Getting Started Guide* (included in the shipping box) or to the *Talari APN Appliance Quick Start Guide* (available at <http://www.talari.com/support>) for instructions on how to access and use the web console to configure the management IP address.

Troubleshooting

The following section outlines some troubleshooting steps and guidelines for the T3010 and T5000.

Basic Troubleshooting

The key to problem solving is to isolate the problem to a specific subsystem by comparing what the appliance is doing to what it should be doing. The T3010 and T5000 have LEDs and NIC indicators on the rear panel for the indication of power, disk activity, Ethernet activity, etc. These indicators can assist in isolating the problem to a specific subsystem.

Appliance Troubleshooting Basics

Problem	Resolution
Cannot ping the T3010 or T5000	Make sure the appliance has power. Confirm that the device has a management IP address assigned. Verify that the management port has connectivity from the appliance and switch.
Ethernet port not forwarding traffic	Verify that the switch has auto-negotiation enabled. Verify that the port is enabled on the switch. Confirm that you are connected to the correct port on the Talari.
Cannot access the Talari Web Console	Confirm that you are using the correct IP address. Confirm that the management port of the T3010 or T5000 is connected to a switch and there is activity.
LEDs do not turn on	Check the AC power source. Check the appliance's On/Off buttons.

Table 3: Troubleshooting Basics

Troubleshooting Bypass Mode (Fail-to-Wire)

The T3010 and T5000 are equipped with a capability known as “bypass mode” or “fail-to-wire.” This capability is designed to prevent a single point of failure. If there is a serious problem with the appliance, the bypass pair enters bypass mode and forwards traffic through as though the appliance were a wire.

A bypass pair may be configured as either “fail-to-wire” or “fail-to-block.” If a bypass pair is configured for “fail-to-block,” bypass mode is not activated even if power is lost. Bypass pairs are configured as “fail-to-wire” by default.

Bypass mode is used when the appliance is not powered on, when the appliance is powered on but is not configured, or when the appliance is powered on and configured but the Talari Service is disabled. When the T3010 or T5000 is in bypass mode, one or both of the bypass LEDs will stop blinking green.

Please also see [Important Note about Cabling and Bypass Mode](#) for additional information.

Problem	Resolution
Bypass mode blocking traffic	Verify that the T3010 or T5000 has connectivity to the L2/L3 devices on its LAN/WAN ports. Verify that the correct cables are used and that the networking devices have auto-negotiate set for their ports.
T3010 or T5000 stays in bypass mode	Confirm that the T3010 or T5000 Appliance is configured properly and that the Talari Service is enabled.

Table 4: Troubleshooting Bypass Mode

