

Oracle Identity Manager Integration Implementation Guide  
Oracle FLEXCUBE Universal Banking

Release 12.87.03.0.0

July 2017

Part No. E8, S&T-01



---

# Table of Contents

<b>1. INTRODUCTION</b>	<b>1-1</b>
<b>2. REQUIREMENTS / PROBLEM STATEMENT</b>	<b>2-1</b>
<b>3. PREREQUISITES</b>	<b>3-1</b>
3.1 SOFTWARE REQUIRED	3-1
3.2 FLEXCUBE COMPONENT REQUIRED	3-2
<b>4. SYSTEM DESCRIPTION</b>	<b>4-1</b>
4.1 ABOUT ORACLE IDENTITY MANAGER	4-1
4.1.1 <i>Oracle Identity Manager System Components</i>	4-1
4.2 INTEGRATION / DESIGN ARCHITECTURE	4-4
4.2.1 <i>Provisioning Design Architecture</i>	4-4
4.2.2 <i>Reconciliation Design Architecture</i>	4-5
4.2.3 <i>Design Constraints</i>	4-5
4.2.4 <i>Message Flow</i>	4-6
<b>5. INSTALLATION / CONFIGURATION</b>	<b>5-1</b>
5.1 ENVIRONMENT SETUP/CONFIGURATIONS	5-1
5.1.1 <i>Enabling SSL for Weblogic and OIM Server</i>	5-1
5.1.2 <i>Enabling SSL on GTC Connector Server</i>	5-5
5.1.3 <i>Configuring SSL Mode in Oracle Internet Directory</i>	5-7
5.1.4 <i>OIM FLEXCUBE Adapter Setup</i>	5-11
5.1.5 <i>OIM Setup</i>	5-26
5.1.6 <i>System Configurations</i>	5-60
<b>6. SOLUTION / USAGE GUIDELINES</b>	<b>6-1</b>
6.1 WORKING WITH OIM	6-1
6.1.1 <i>Creating a user in FLEXCUBE through OIM</i>	6-1
6.1.2 <i>Modifying a user in FCUBS through OIM</i>	6-8
6.1.3 <i>Disable/Remove Accounts in FCUBS through OIM</i>	6-11
6.1.4 <i>Enabling a Disabled user in FCUBS through OIM</i>	6-13
6.1.5 <i>Running Reconciliation in OIM</i>	6-14
<b>7. REFERENCE</b>	<b>7-1</b>
<b>8. APPENDIX</b>	<b>8-1</b>
8.1 DATA SOURCE CREATION	8-1

---

# 1. Introduction

For the purpose of centralized user provisioning FLEXCUBE is qualified with Oracle Identity Manager - Oracle® Fusion Middleware 11g Release 2 (11.1.2.2.0). This feature is available in FLEXCUBE since the release FCUBS V.UM 10.1.0.0.0.0.0.

## Scope

This document provides an understanding as to how centralized provisioning through OIM can be enabled for FCUBS.

In addition to providing a background to the various components of the deployment, this document provides detailed steps as to how to install the various FCUBS components required for the integration with OIM configuration in FCUBS and Oracle Identity Manager to enable centralized provisioning.

## Introduction to Oracle Identity Manager

Oracle Identity Manager is an identity management product that automates user provisioning, identity administration, and password management, integrated in a comprehensive workflow engine. It enables organizations to reduce Information Technology (IT) administration costs and improve security. Oracle identity manager achieves this by providing a centralized control mechanism to manage the entire life cycle of user identities and entitlements and to control user access to across all resources in the organization.

## Advantage

Integrating FCUBS with Oracle identity Manager provides capability for managing the entire life cycle of FCUBS user identities through a centralized point provided by OIM in both scenario- FCUBS without single sign on and FCUBS with single sign on.

---

## 2. Requirements / Problem Statement

The requirement is to integrate FCUBS with Oracle Identity Manager for FCUBS user provisioning and de-provisioning services with and without FCUBS single sign on.

## 3. Prerequisites

### 3.1 Software Required

Oracle® Fusion Middleware 11g Release 2 (11.1.2.2.0)

Refer [Oracle Identity Manager Document](#) for Installation and configuration of Oracle Identity Manager.

While Configuring Oracle Identity Management, uncheck Enable LDAP Sync option like shown below:

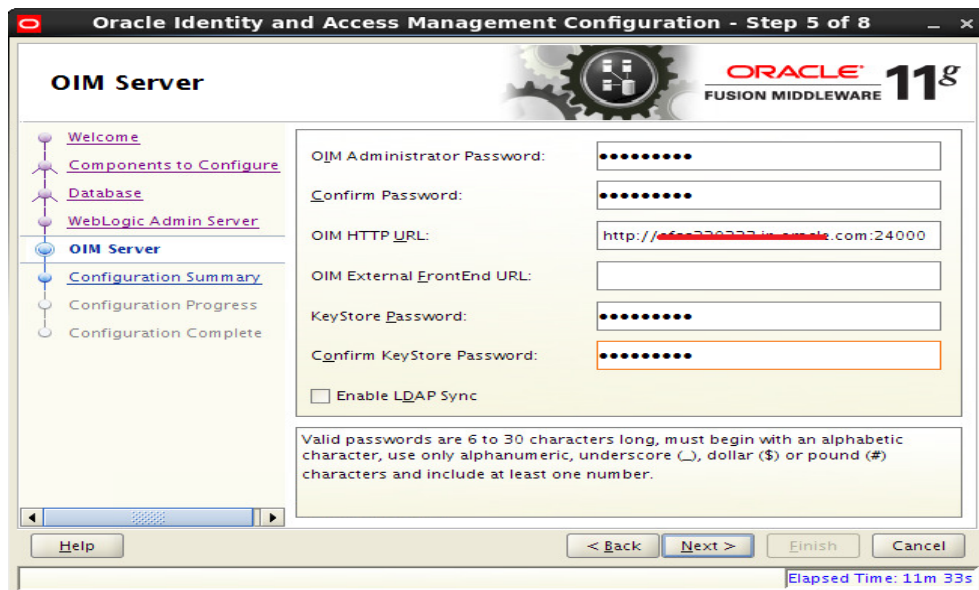

Note \*: To get the Keystore Password in the above screen while configuring OIM Console, you should have only Weblogic Admin Server, OIM Server and SOA Server in this OIM Domain. Based on that the below keystore will be created with store password

<Domain\_home>/config/fmwconfig/default-keystore.

- Oracle Internet Directory Connector 11.1.1.6.0
- Refer the below sections:
  - Installation of Oracle Internet Directory Connector (Section 2.2.1.1, 2.2.1.2 & 2.3.1.1)
  - Connector by default will be available with Oracle Identity and Access Management Suite.

The path will be as follows :

<Oracle\_Middleware>/<OIM\_HOME>/connector/oid

For example:

Linux: /app/oracle/Middleware/Oracle\_IDM1/connector/oid

Windows: C:\apps\oracle\Middleware\Oracle\_IDM1\connector\oid

The above directory <oid> has to be copied into

<Oracle\_Middleware>/<OIM\_HOME>/server/ConnectorDefaultDirectory

> Configuring Oracle Identity Manager Design Console

## 3.2 **FLEXCUBE Component Required**

FLEXCUBE Gateway EJB

---

## 4. System Description

### 4.1 About Oracle Identity Manager

Oracle Identity Manager is an identity management product that automates user provisioning, identity administration, and password management, integrated in a comprehensive workflow engine. Key features of Oracle Identity Manager include password management, workflow and policy management, identity reconciliation, reporting and auditing, and extensibility through adapters.

#### 4.1.1 Oracle Identity Manager System Components

Oracle Identity Manager is built on an enterprise-class, modular architecture that is both open and scalable. Each module plays a critical role in the overall functionality of the system:

##### **Identity Administration**

Identity administration includes creation and management of identities in Oracle Identity Manager. Identities include users, organizations, and roles. Identity administration also enables password management and user Oracle Identity Manager Self Service operations. Identity administration is performed by using Oracle Identity Manager Administration and Oracle Identity Manager Self Service Web clients, and the SPML Web service.

##### **Provisioning**

The provisioning transactions are assembled and modified in the provisioning module. This module maintains the "who" and "what" of provisioning. User profiles, access policies, and resources are defined in the provisioning module, as are business process workflows and business rules.

The Provisioning Server is the run-time engine for Oracle Identity Manager. It runs the provisioning process transactions as defined through Oracle Identity Manager Administration and Oracle Identity Manager Design Console and maintained within the provisioning module.

##### **Audit and Reports**

The audit and compliance functions include evaluating a person, organization, system, process, project, or product. This occurs by capturing data generated by the suite's workflow, policy, and reconciliation engines. By combining this data with identity data, an enterprise has all the information it requires to address any identity and to access a related audit inquiry. Audits are performed to ascertain the validity and reliability of information, and also provide an assessment of a system's internal control.

Reporting is the process of generating a formal document, which is created as a result of an audit. The report is subsequently provided to a user, such as an individual, a group of persons, a company, a government, or even the general public, as an assurance service so that the user can make decisions, based on the results of the audit. An enterprise can create reports on both the history and the current state of its provisioning environment. Some captured identity data includes user identity profile history, role membership history, user resource access, and fine-grained entitlement history.

##### **Reconciliation and Bulk Load**

The reconciliation engine ensures consistency between the provisioning environment of Oracle Identity Manager and Oracle Identity Manager managed resources within the organization. The reconciliation engine discovers illegal accounts created outside Oracle Identity Manager. The reconciliation engine also synchronizes business roles located inside and outside the provisioning system to ensure consistency.

If you want to load a large amount of data from other repositories in your organization into Oracle Identity Manager, then you can use the Bulk Load utility. The Bulk Load utility reduces the downtime in loading the data. In addition, Bulk Load utility import Oracle Identity Manager users, roles, role memberships, and accounts provisioned to users.

## Common Services

Various services are grouped together that are shared and used by other Oracle Identity Manager components. These services are:

**Form Designer:** A form that allows you to create process and resource object forms that do not come packaged with Oracle Identity Manager.

**Scheduler:** A service that provides the capability to run specific jobs at specific schedules. This service can be used by users, application developers, connector developer, and administrators to create and configure a Job to be run at specified intervals. In addition, this service provides administrative capabilities to manage the functionality of jobs and their schedules.

**Notification Templates:** A common notification service is used by other functional components to send notifications to interested parties about events occurring in Oracle Identity Manager. In addition, this service provides the administrative capabilities for notification template management. A notification template is used for sending the outgoing notifications. These templates typically contain the variables that refer to the available data to provide more contextual content.

**System Properties:** A system property is an entity that controls the configuration aspect of an application. In addition, to the default system properties, you can create and manage system properties in Oracle Identity Manager.

**Deployment Manager:** The Deployment Manager is a tool for exporting and importing Oracle Identity Manager configurations. The Deployment Manager enables you to export the objects that make up your Oracle Identity Manager configuration.

## Workflow and Request Management

Various operations in Oracle Identity Manager cannot be performed directly. Instead, the operations must be requested. The request management service provides a mechanism to create, approve, and manage requests. A request is an entity created by the users or administrators who want to perform a specific action, which requires a discretionary permission to be obtained from someone or some process before the action can be performed. For example, a user can create a request to gain access to a laptop computer, a manager can approve the request and create an open requisition, and an IT resource administrator can approve the request.

The primary goal of a provisioning solution is to manage requests and provision resources. Request service provides an abstraction layer on the Business Process Execution Language (BPEL) 11g workflow engine. Functional components such as request, provisioning, and attestation interacts with the workflow engine for human approvals. Request service caters to the various functional components in Oracle Identity Manager by managing workflow instances and categories, and provides an abstraction layer on BPEL.

## Infrastructure and Middleware Integration

The Adapter Factory, Kernel Orchestration mechanism, Context Manager, and Plug-in Framework are designed to eliminate the need for hard-coding integrations with these systems.

## Connector Framework



The integration solution strategy of Oracle Identity Manager provides connectors to various heterogeneous identity-aware IT systems. This strategy is designed to minimize custom development, maximize the reuse of code, and reduce deployment time. The tiers of the integration solution are:

- Out-of-the box integration using predefined connectors and predefined generic technology connector providers
- Identity connectors that are designed to separate the implementation of an application from the dependencies of the system that the application is attempting to connect to
- Connectors based on custom generic technology connector providers
- Custom connectors using the Adapter Factory

Following figure illustrates the system components of Oracle Identity Manager.

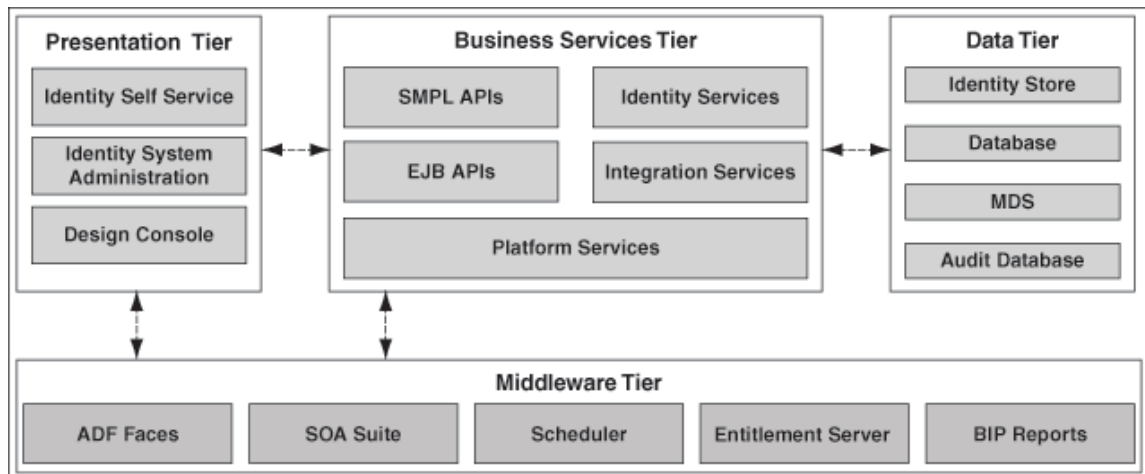

## 4.2 Integration / Design Architecture

With the integration of FCUBS and Oracle Identity Manager, a user can be created, modified, closed, and reopened in FCUBS. Oracle Identity Manager acts as the front-end entry point for managing mandatory fields of FCUBS user. After users are provisioned, the users can access the FCUBS without any interaction with Oracle Identity Manager. This integration also ensures that any change that has been made for corresponding user in FCUBS should be reflected in OIM using reconciliation feature of OIM.

### Design

For the purpose of integration of Oracle Identity manager and FCUBS “Generic technology connector” (GTC) has been used. GTC provides out of box providers for provisioning and reconciliation.

Following two figures illustrate the design aspect of the provisioning and reconciliation process:

### 4.2.1 Provisioning Design Architecture

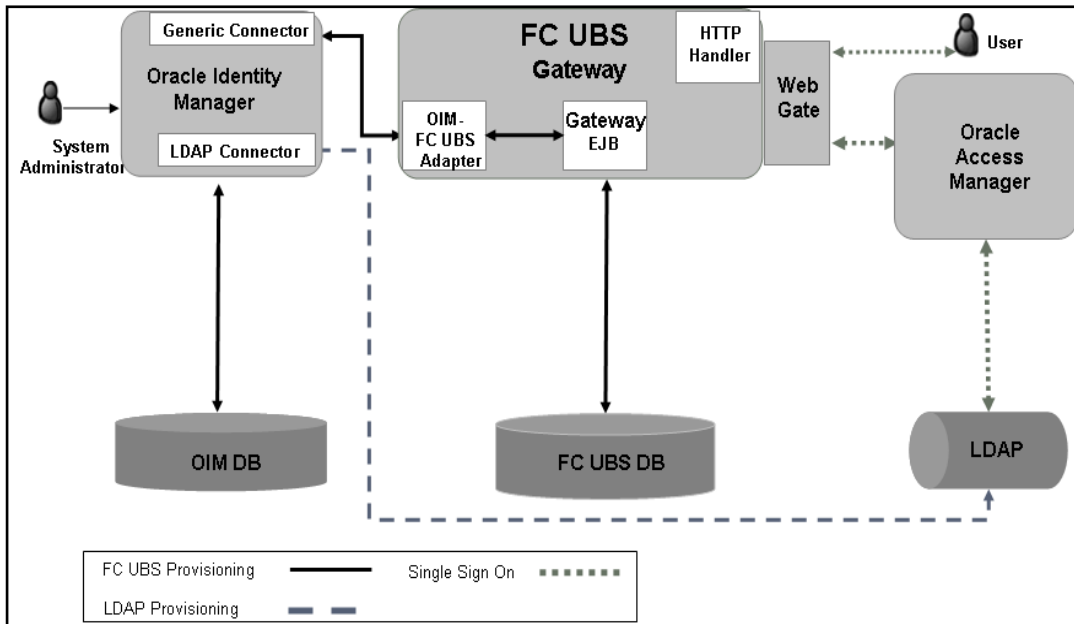

#### 4.2.2 Reconciliation Design Architecture

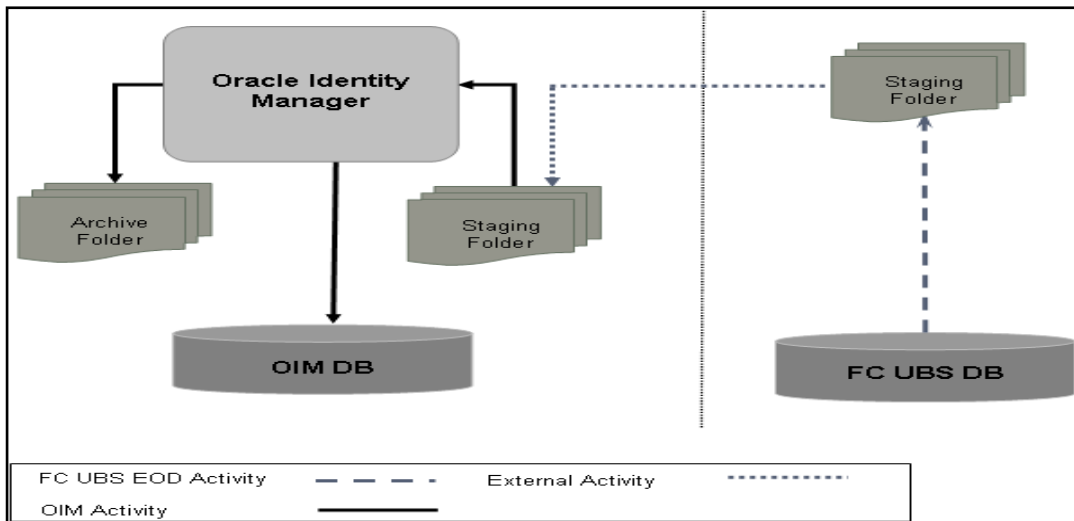

#### 4.2.3 Design Constraints

The followings are the design constraints for this integration:

- This integration is based upon sample configuration containing only mandatory fields of FCUBS user while defining the GTC. Other fields can be defined in the GTC using the same configurations.
- Due to specific data requirement for FCUBS user creation, only manual provisioning method can be used for FCUBS provisioning.
- User role is not taken up in this integration and the FCUBS user will not be associated with any role at the time of user creation.
- A common FCUBS maker id will be used for user creation that is maintained as property in a property file.

- OIM does not allow ASCII special characters e.g. ampersand, colon, braces etc. Apart from this, OIM also does not allow multiple consecutive occurrences of some of special ASCII character like underscore etc.

#### 4.2.4 Message Flow

OIM-FCUBS adapter would transform the request from the OIM SPML/DSML to FCUBS Gateway request using Extensible Style sheet Language Transformation (XSLT). Transformed XML request will be sent to the FCUBS Gateway EJB for further processing based on the type of the request. Based on the FCUBS Gateway EJB response OIM-FCUBS adapter will prepare the response in SPML/DSML format and will send to the OIM.

Following gives the sequence of the message exchanges between the adapter and FCUBS Gateway EJB for user provisioning that are initiated from OIM.

##### 4.2.4.1 Message exchange sequence for User Creation

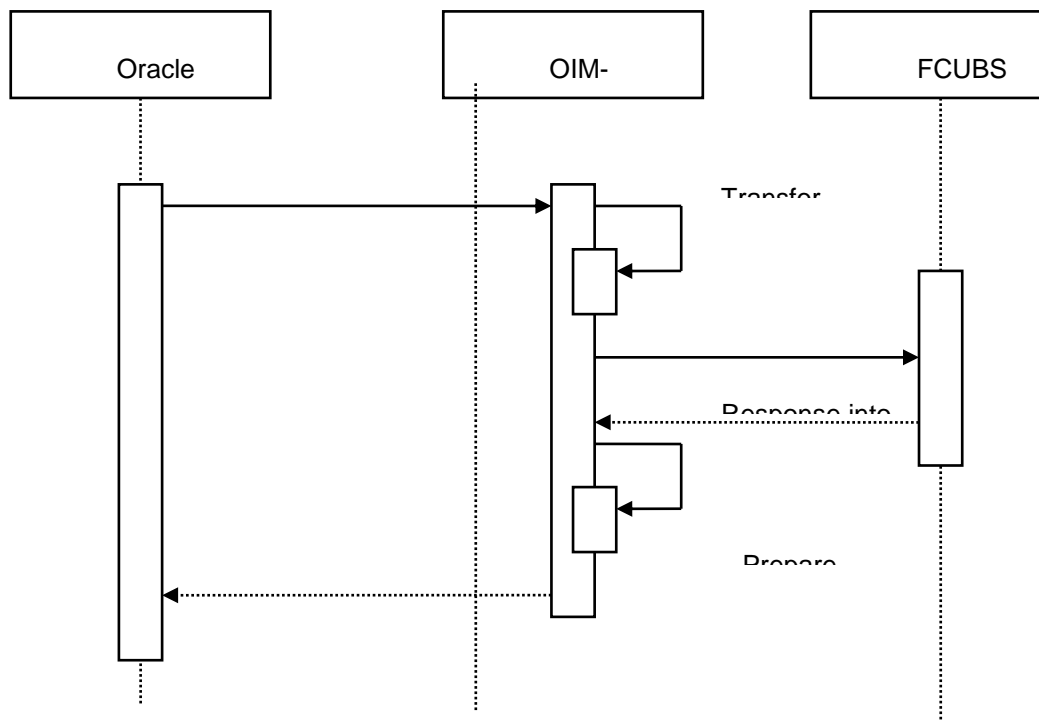

#### 4.2.4.2 Message exchange sequence for User Field Modification/Set Password

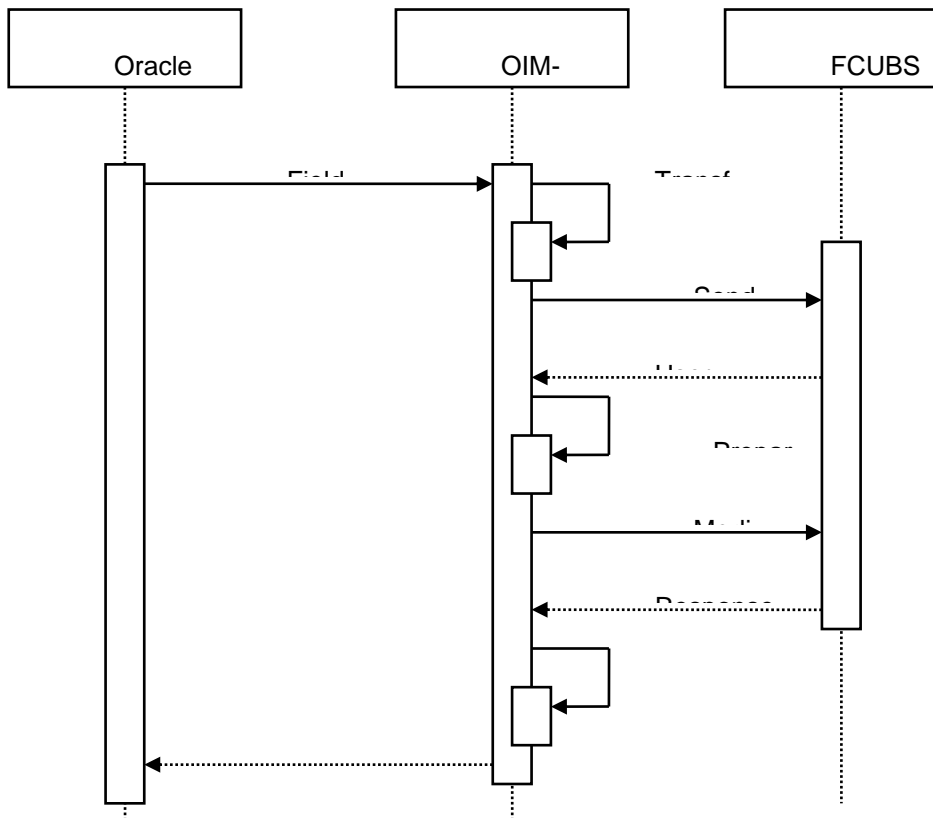

### 4.2.4.3 Message exchange sequence for User Delete/Suspend/Resume Request

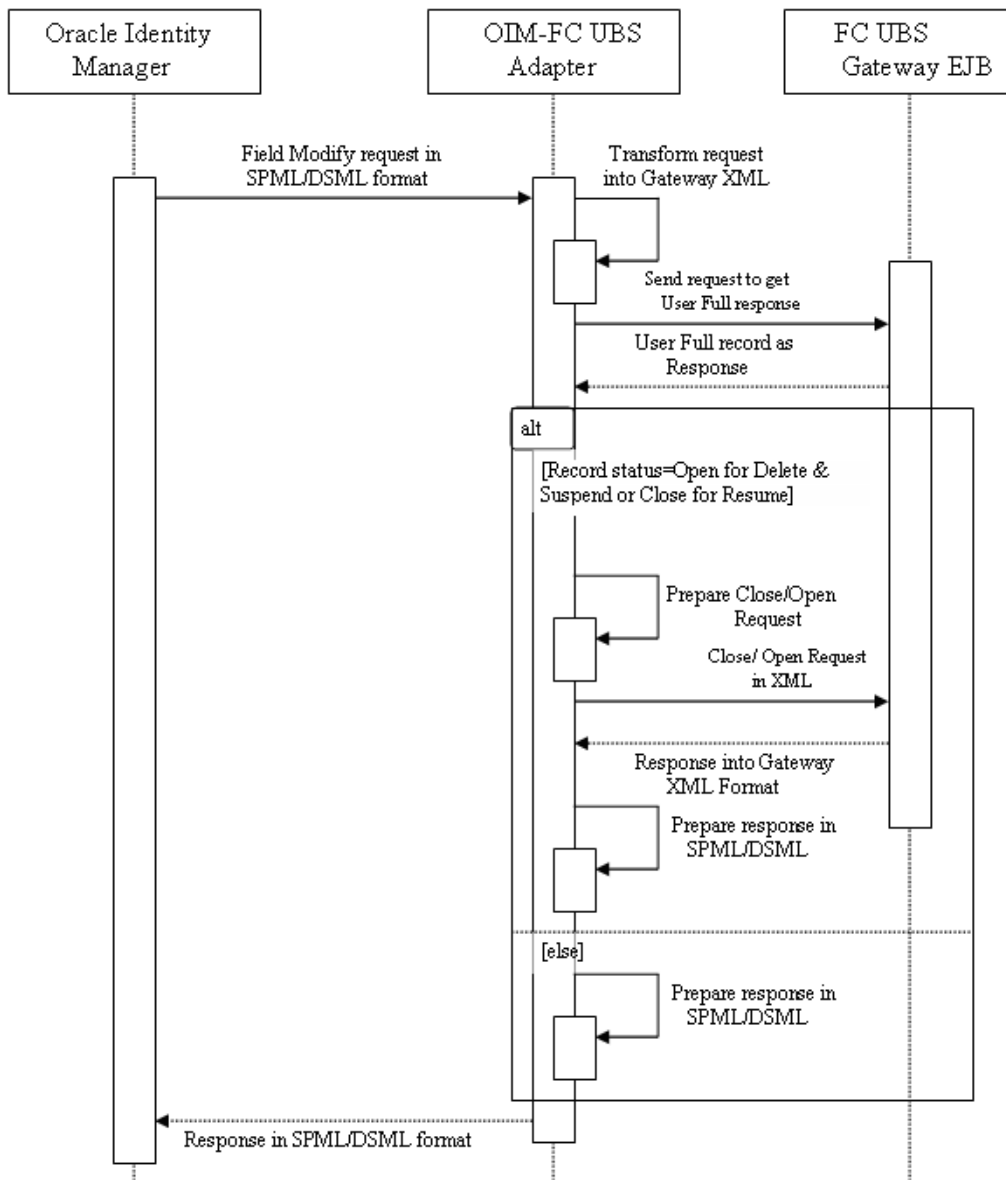

---

## 5. Installation / Configuration

### 5.1 Environment Setup/Configurations

FLEXCUBE - OIM Integration environment setup requires

- OIM FLEXCUBE Adapter setup & configuration
- OIM setup

Note: This implementation document describes the installation and setup of OIM FLEXCUBE Adapter on Oracle Fusion Middleware 11g Release 2 (11.1.2.2.0).

#### 5.1.1 Enabling SSL for Weblogic and OIM Server

##### 5.1.1.1 Self-Signed Certificate Creation

To enable SSL mode, Weblogic requires a keystore which contains private and trusted certificates. We have to use the same version of JDK (which is used by Weblogic Domain), to create the keystore and certificates, otherwise it may lead to many difficulties (suggested by Oracle Support).

Keytool utility available in Java JDK will be used to create Keystore. In command prompt set PATH to the JDK\bin location. Follow the below steps to create keystore and self-signed certificates:Keystore Creation

```
keytool -genkey -keystore <keystore_name.jks> -alias <alias_name> -dname "CN=<hostname>,
OU=<Organization Unit>, O=<Organization>, L=<Location>, ST=<State>, C=<Country_Code>" -keyalg
<Key Algorithm> -sigalg <Signature Algorithm> -keysize <key size> -validity <Number of Days> -
keypass <Private key Password> -storepass <Store Password>
```

For example:

```
keytool -genkey -keystore AdminFlexcubeKeyStore.jks -alias FlexcubeCert -dname
"CN=ofss00001.in.oracle.com, OU=OFSS, O=OFSS, L=Chennai, ST=TN, C=IN" -keyalg "RSA" -sigalg
"SHA1withRSA" -keysize 2048 -validity 3650 -keypass Password@123 -storepass Password@123
```

**Note:** CN=ofss00001.in.oracle.com is the Host Name of the weblogic server

##### 5.1.1.2 Export Private key as Certificate

```
keytool -export -v -alias <alias_name> -file <export_certificate_file_name_with_location.cer> -keystore
<keystore_name.jks> > -keypass <Private key Password> -storepass <Store Password>
```

For example:

```
keytool -export -v -alias FlexcubeCert -file AdminFlexcubeCert.cer -keystore AdminFlexcubeKeyStore.jks
-keypass Password@123 -storepass Password@123
```

##### 5.1.1.3 Import as Trusted Certificate

```
keytool -import -v -trustcacerts -alias rootcert -file <export_certificate_file_name_with_location.cer> -
keystore <keystore_name.jks> > -keypass <Private key Password> -storepass <Store Password>
```

For example:

```
keytool -import -v -trustcacerts -alias rootcert -file AdminFlexcubeCert.cer -keystore AdminFlexcubeKeyStore.jks -keypass Password@123 -storepass Password@123
```

References: Oracle Support Articles (Article ID 1281035.1, Article ID 1218695.1), in case of Certificates issued by the Trusted Authorities

#### 5.1.1.4 Configuring Weblogic Console

After domain creation, follow the below steps to enable SSL in Weblogic Admin server, OIM Server and SOA Server.

Select Admin Server to enable SSL options.

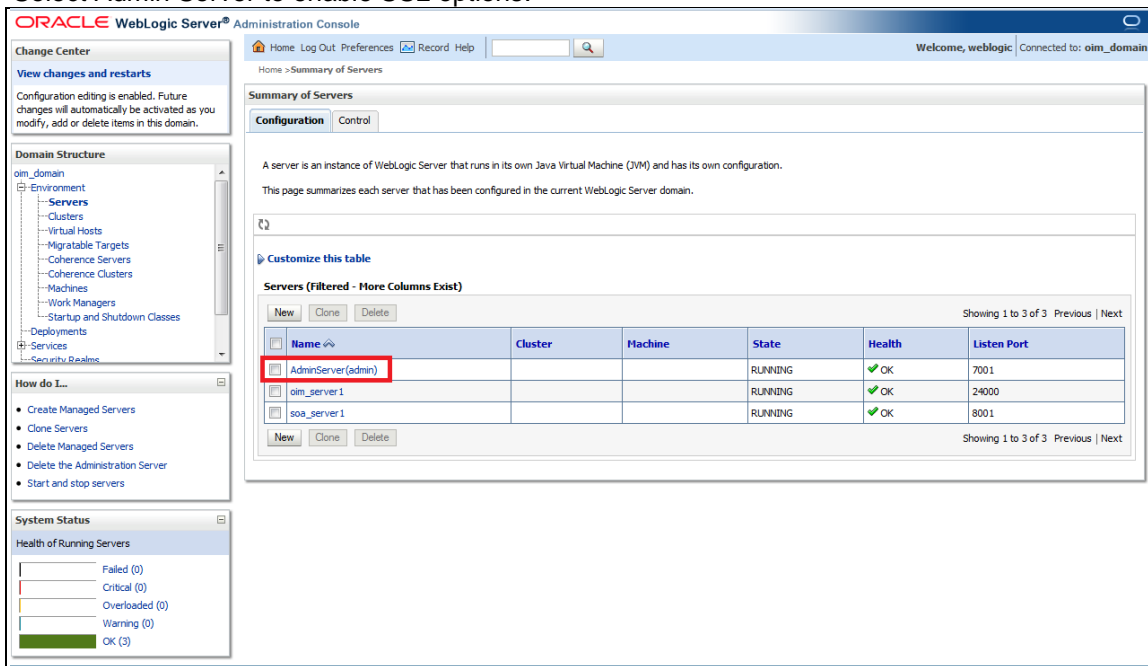

The screenshot shows the Oracle WebLogic Server Administration Console interface. The main content area displays the 'Summary of Servers' page, which includes a table of servers. The 'AdminServer(admin)' server is highlighted with a red box. The table has columns for Name, Cluster, Machine, State, Health, and Listen Port. The 'AdminServer(admin)' server is in a 'RUNNING' state with a 'Health' of 'OK' and a 'Listen Port' of 7001. Other servers listed are 'oim\_server1' and 'soa\_server1', both also in 'RUNNING' state with 'OK' health and listen ports of 24000 and 8001 respectively.

Name	Cluster	Machine	State	Health	Listen Port
AdminServer(admin)			RUNNING	OK	7001
oim_server1			RUNNING	OK	24000
soa_server1			RUNNING	OK	8001

Follow the steps in General Tab as shown below:

1. Select SSL Listen Port Enabled, Client Cert Proxy Enabled, Weblogic Plug-In Enabled.
2. Click on Save.



**General** Cluster Services Keystores SSL Federation Services Deployment Migration Tuning Overload Health Monitoring Server Start Web Services

**Save**

Use this page to configure general features of this server such as default network communications.  
View JNDI Tree

**Name:** AdminServer An alphanumeric name for this server instance. [More Info...](#)

**Machine:** (None) The WebLogic Server host computer (machine) on which this server is meant to run. [More Info...](#)

**Cluster:** (Standalone) The cluster, or group of WebLogic Server instances, to which this server belongs. [More Info...](#)

**Listen Address:** The IP address or DNS name this server uses to listen for incoming connections. [More Info...](#)

**Listen Port Enabled** Specifies whether this server can be reached through the default plain-text (non-SSL) listen port. [More Info...](#)

**Listen Port:** 7001 The default TCP port that this server uses to listen for regular (non-SSL) incoming connections. [More Info...](#)

**SSL Listen Port Enabled** Indicates whether the server can be reached through the default SSL listen port. [More Info...](#)

**SSL Listen Port:** 7002 The TCP/IP port at which this server listens for SSL connection requests. [More Info...](#)

**Client Cert Proxy Enabled** Specifies whether the HttpClusterServlet proxies the client certificate in a special header. [More Info...](#)

**Java Compiler:** javac The Java compiler to use for all applications hosted on this server that need to compile Java code. [More Info...](#)

**Diagnostic Volume:** Low Specifies the volume of diagnostic data that is automatically produced by WebLogic Server at run time. Note that the WLDLF diagnostic volume setting does not affect explicitly configured diagnostic modules. For example, this controls the volume of events generated for JRockit Flight Recorder. [More Info...](#)

**Advanced**

**Virtual Machine Name:** iam\_domain\_AdminSe When WLS is running on JRIE, this specifies the name of the virtual machine running this server. [More Info...](#)

**WebLogic Plug-In Enabled** Specifies whether this server uses the proprietary WL-Proxy-Client-IP header, which is recommended if the server instance will receive requests from a proxy plug-in. [More Info...](#)

Follow the steps in Keystores Tab as shown below:

1. Click Change and select Keystores as **Custom Identity and Custom Trust**
2. Click on Save
3. Note: Keystores as **Custom Identity and Custom Trust** is as suggested by Oracle Support Team

**ORACLE** WebLogic Server® Administration Console

Home Log Out Preferences Record Help Welcome, weblogic Connected to: iam\_domain

Home > Summary of Servers > AdminServer

**Settings for AdminServer**

**Configuration** Protocols Logging Debug Monitoring Control Deployments Services Security Notes

General Cluster Services **Keystores** SSL Federation Services Deployment Migration Tuning Overload Health Monitoring Server Start Web Services

**Save** Cancel

Keystores ensure the secure storage and management of private keys and trusted certificate authorities (CAs). This page lets you view and define various keystore configurations. These settings help you to manage the security of message transmissions.

**Keystores:** Demo Identity and Demo Trust Which configuration rules should be used for finding the server's identity and trust keystores? [More Info...](#)

Custom Identity and Command Line Trust

**Custom Identity and Custom Trust**

Custom Identity and Java Standard Trust

Demo Identity and Demo Trust

**Save** Cancel

WebLogic Server Version: 10.3.5.0  
Copyright © 1996-2010, Oracle and/or its affiliates. All rights reserved.  
Oracle is a registered trademark of Oracle Corporation and/or its affiliates. Other names may be trademarks of their respective owners.

Follow the steps in Keystores Tab as shown below:

4. Enter Custom Identity Keystore and Custom Trust Keystore as same as the Keystore Name created in step [5.1.1.2](#) with full path.
5. Enter Custom Identity Keystore Type and Custom Trust Keystore Type as jks.
6. Enter Custom Identity Keystore Passphrase, Confirm Custom Identity Keystore Passphrase, Custom Trust Keystore Passphrase and Confirm Custom Trust Keystore Passphrase as same as the Store Password entered in step [5.1.1.2](#).
7. Click on Save.

The screenshot displays the Oracle WebLogic Server Administration Console interface. The main content area is titled "Settings for AdminServer" and is divided into several tabs: Configuration, Protocols, Logging, Debug, Monitoring, Control, Deployments, Services, Security, and Notes. The "Keystores" tab is active, showing a "Save" button at the top left. Below the "Keystores" section, there is a "Custom Identity and Custom Trust" configuration area. The "Identity" section includes fields for "Custom Identity Keystore" (nFlexcubeKeystore.jks), "Custom Identity Keystore Type" (jks), "Custom Identity Keystore Passphrase" (masked with dots), and "Confirm Custom Identity Keystore Passphrase" (masked with dots). The "Trust" section includes fields for "Custom Trust Keystore" (nFlexcubeKeystore.jks), "Custom Trust Keystore Type" (jks), "Custom Trust Keystore Passphrase" (masked with dots), and "Confirm Custom Trust Keystore Passphrase" (masked with dots). A "Save" button is located at the bottom left of the configuration area.

Follow the steps in SSL Tab as shown below:

1. Enter Private Key Alias as same as the alias name entered in step [5.1.1.2](#).
2. Enter Private Key Passphrase and Confirm Private Key Passphrase as same as the Private Key Password entered in step [5.1.1.2](#).
3. Change the Hostname Verification to None.
4. Click on Save.

The screenshot shows the 'Settings for AdminServer' page in the Oracle WebLogic Server Administration Console. The 'SSL' tab is active, and the 'Save' button is highlighted. The configuration includes:

- Identity and Trust Locations:** Keystores: Change
- Private Key Location:** from Custom Identity Keystore
- Private Key Alias:** FlexcubeCert
- Private Key Passphrase:** [Masked]
- Confirm Private Key Passphrase:** [Masked]
- Certificate Location:** from Custom Identity Keystore
- Trusted Certificate Authorities:** from Custom Trust Keystore
- Advanced:**
  - Hostname Verification:** None
  - Custom Hostname Verifier:** None
- Export Key Lifespan:** 500
- Use Server Certs:** [Checked]

5. Select OIM Server & SOA Server to enable SSL options and Repeat the steps performed in 5.1.1.7 to 5.1.1.10.

The screenshot shows the 'Summary of Servers' page in the Oracle WebLogic Server Administration Console. The table below lists the servers:

Name	Cluster	Machine	State	Health	Listen Port
AdminServer(admin)			RUNNING	OK	7001
oim_server 1			RUNNING	OK	24000
soa_server 1			RUNNING	OK	8001

6. Now the admin server, oim server and soa server are SSL enabled. Restart all three servers.

## 5.1.2 Enabling SSL on GTC Connector Server

To have SSL enabled Provisioning Web Service in 5.1.5.1.4.15. We have to have a two way handshake between GTC Connector Server and the Application Server, where FCUBSProvisioningAdService web service deployed.

### 5.1.2.1 Export the KeyStore Certificate in 5.1.1.2

```
keytool -export -alias <aliasname> -file <exportfilename> -keystore <keystorename> -storetype jks -storepass <keystorepassword> -provider sun.security.provider.Sun
```

For Example:

```
keytool -export -alias FlexcubeCert -file webfile.cer -keystore FlexcubeKeyStore.jks -storetype jks -storepass Password@123 -provider sun.security.provider.Sun
```

### 5.1.2.2 Import the Certificate to Xellarate Key Store

```
keytool -import -trustcacerts -alias <aliasname> -noprompt -keystore <Domain_home>/config/fmwconfig/default-keystore.jks -file <importfilename> -storepass <keystorepassword>
```

For Example:

```
keytool -import -trustcacerts -alias FlexcubeCert -noprompt -keystore /app/Middleware/user_projects/domains/oim_domain/config/fmwconfig/default-keystore.jks -file webfile.cer -storepass Password123
```

Note \*: <Domain\_home>/config/fmwconfig/default-keystore.jks will be the KeyStore Password while configuring OIM Server. To have this feature, you should have only Weblogic Admin Server, OIM Server and SOA Server in this OIM Domain.

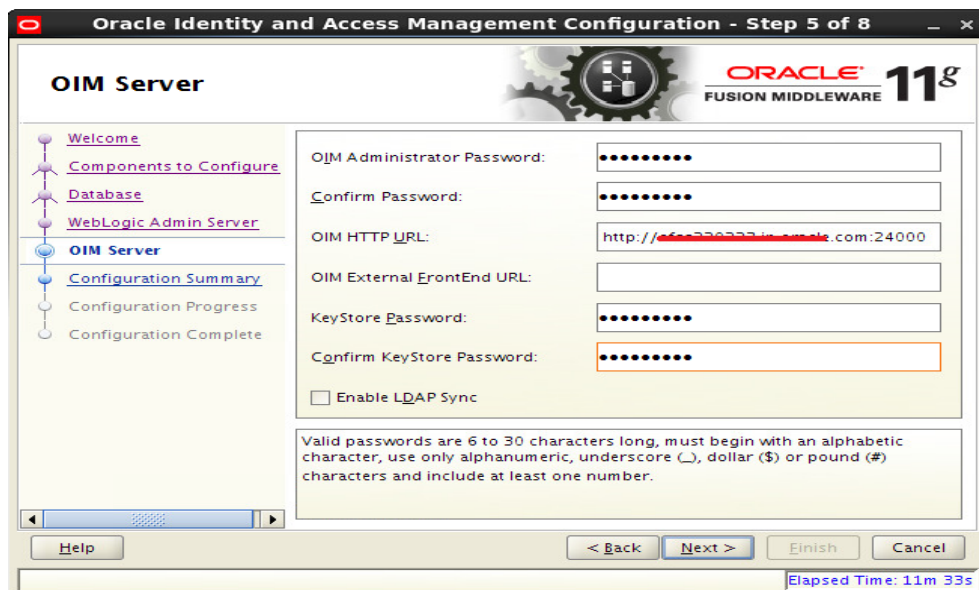

### 5.1.2.3 Export Xellarate KeyStore Certificate

```
keytool -export -alias xell -noprompt -keystore <Domain_home>/config/fmwconfig/default-keystore.jks -file <xellexportfilename> -storetype jks -provider sun.security.provider.Sun
```

For Example:

```
keytool -export -alias xell -noprompt -keystore /app/Middleware/user_projects/domains/oim_domain/config/fmwconfig/default-keystore.jks -file xellcertificate.cer -storetype jks -provider sun.security.provider.Sun
```

### 5.1.2.4 Import the Xellarate Certificate to KeyStore Created in 5.1.1.2

```
keytool -import -alias <aliasname> -trustcacerts -file <xellimportfilename> -keystore <keystorename> -storetype jks -storepass <keystorepassword> -provider sun.security.provider.Sun
```

For Example:

```
keytool -import -alias xellcertificate -trustcacerts -file xellcertificate.cer -keystore FlexcubeKeyStore.jks -storetype jks -storepass Password@123 -provider sun.security.provider.Sun
```

### 5.1.3 Configuring SSL Mode in Oracle Internet Directory

To enable SSL for OID LDAP Server refer and follow the below steps.

1. Login to the Enterprise Manager Console of the domain, in which Oracle Internet Directory is associated.

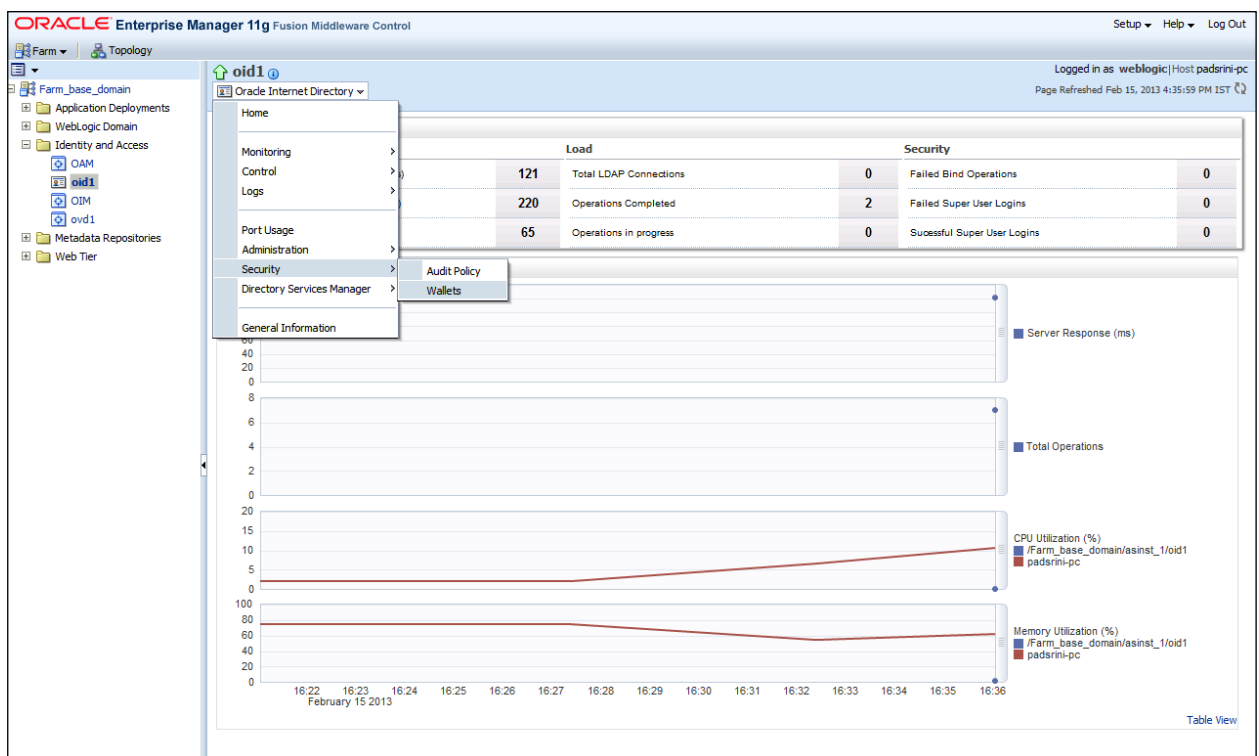

2. Click on Create Self-Signed Wallet.

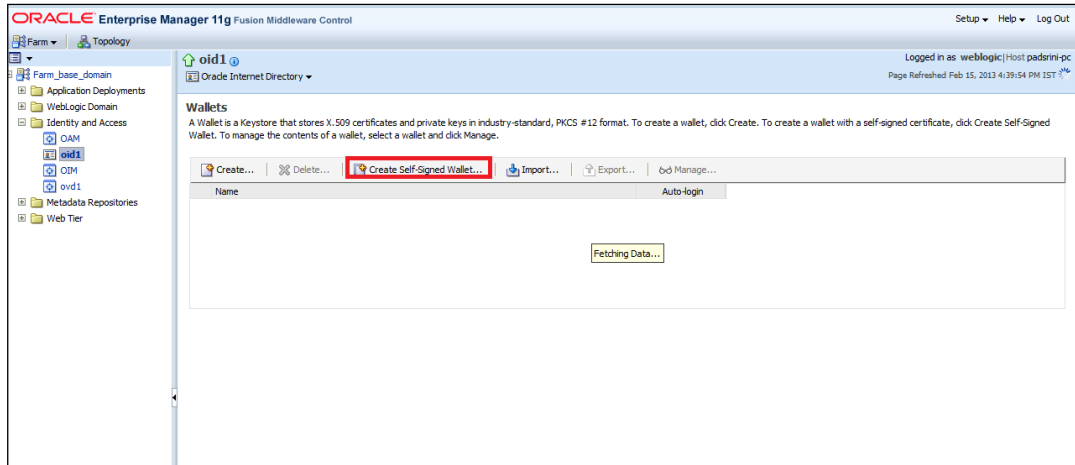

3. Enter the Details as below & Click on OK.

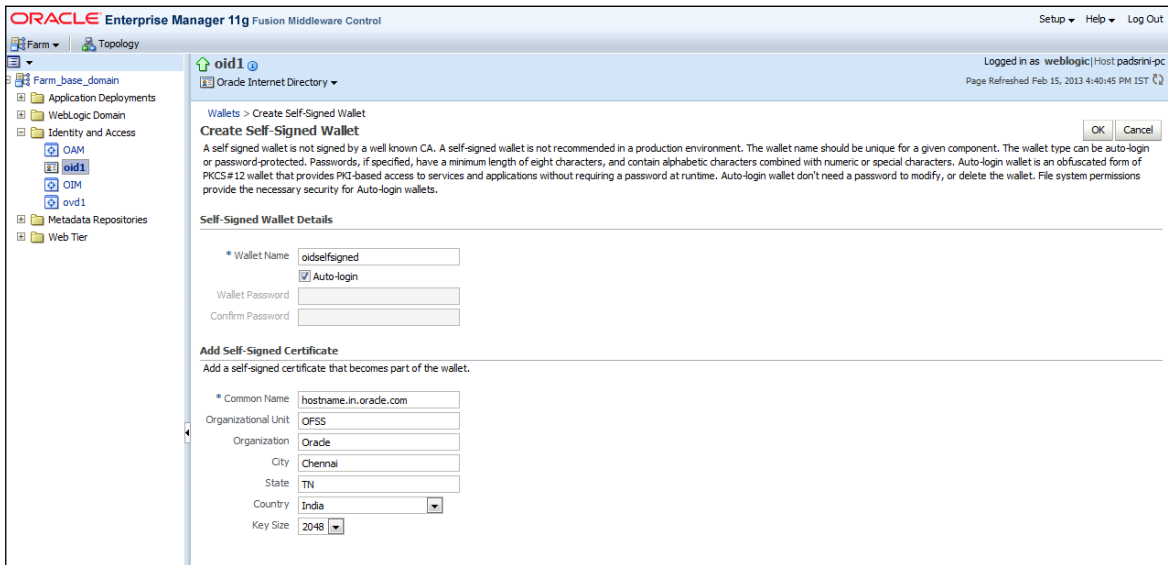

4. Click on  Manage...

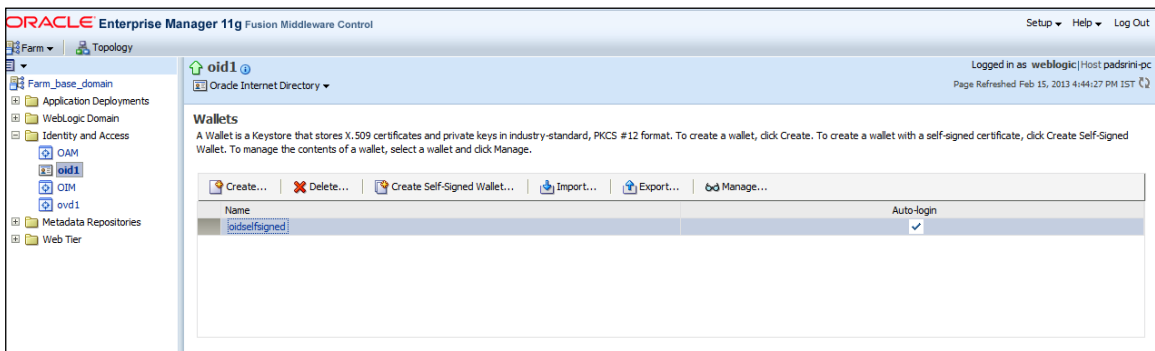

5. Select the Trusted Certificate & Click on Export.

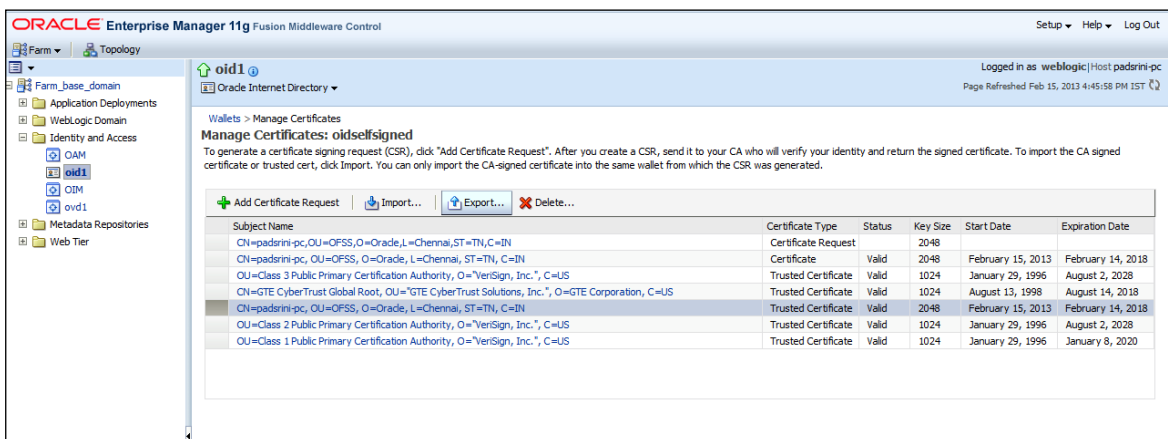

6. Click Export Trusted Certificate and save the certificate file.

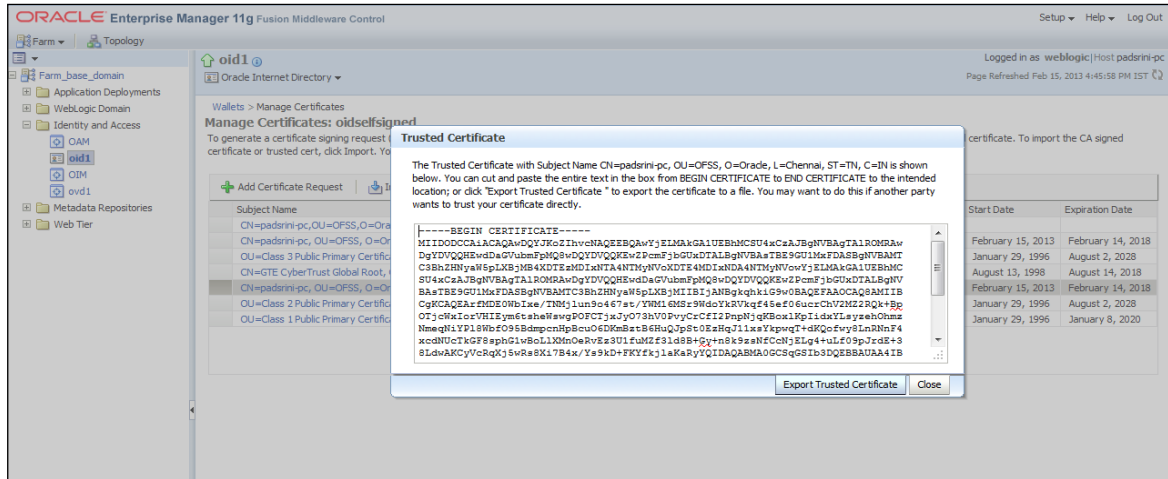

7. Click on Server Properties.

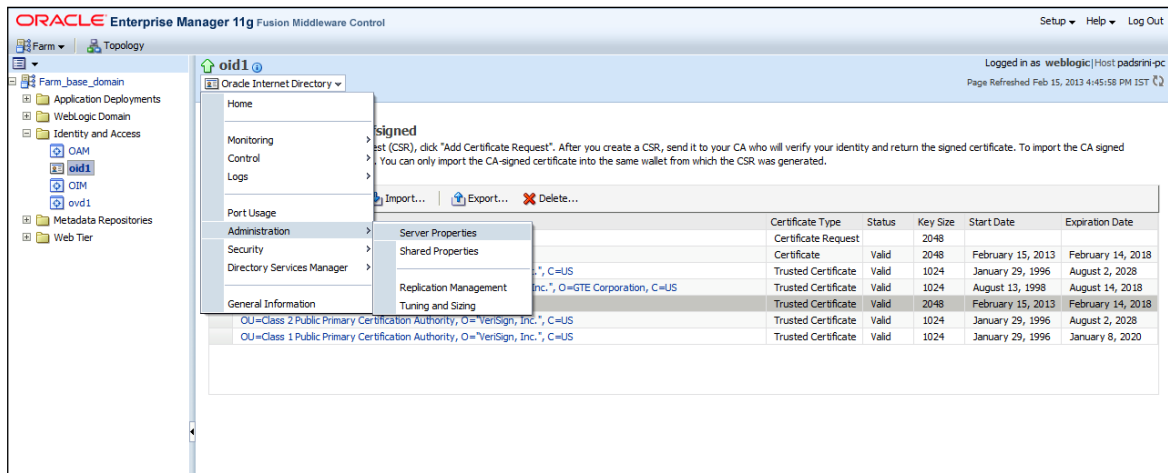

8. Click on Change SSL Settings.

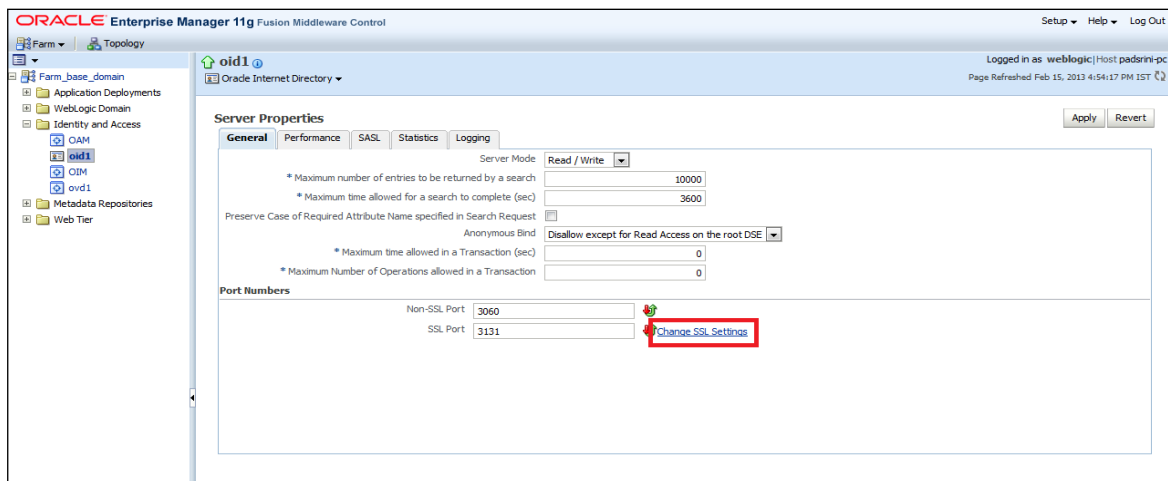

9. Select the Wallet, SSL Authentication as Server Authentication, Cipher Suite, SSL Protocol Version as below & Click on OK.



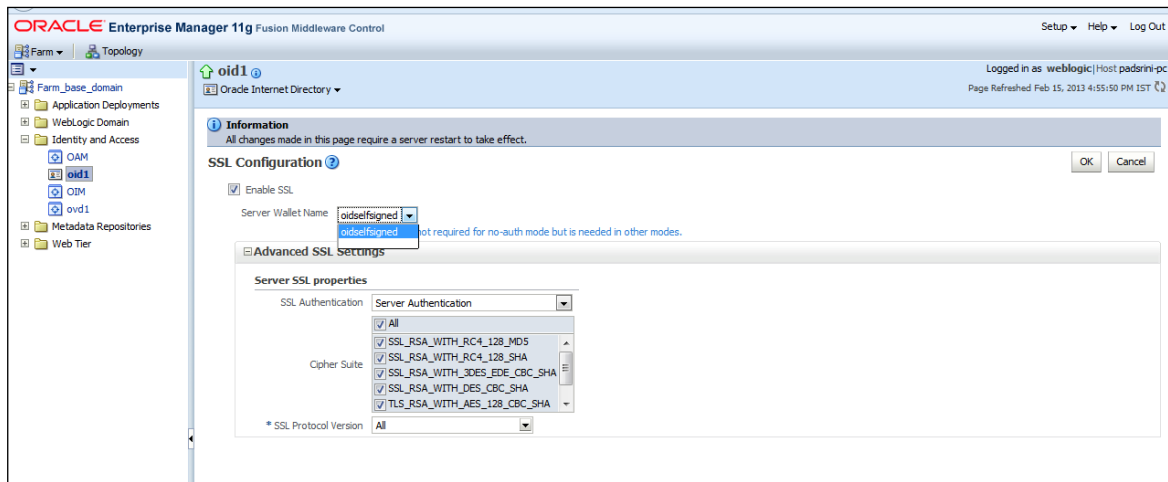

10. Click on Apply.

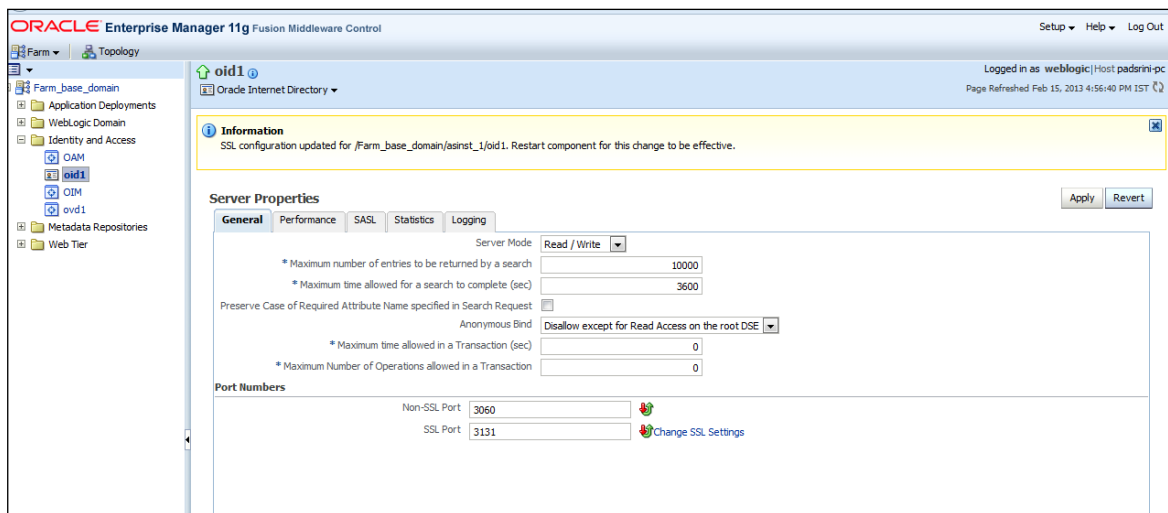

### 5.1.3.1 Import LDAP Server SSL Certificate into OIM Server

Import the Exported Certificate into `wlserver_10.3/server/lib/DemoTrust.jks` of OIM Server Domain using the below command [ Store Password is `DemoTrustKeyStorePassPhrase` ]

```
keytool -import -keystore MW_HOME/wlserver_10.3/server/lib/DemoTrust.jks -file /home/testoc4j/OIM/globalv.crt -storepass DemoTrustKeyStorePassPhrase
```

Restart Both OID & OIM Server.

### 5.1.4 OIM FLEXCUBE Adapter Setup

**Prerequisite:** Gateway EJB component

OIM FCUBS adapter consists of two web services:

- FCUBSLOVAdService : To fetch list of values from FCUBS Database
- FCUBSProvisioningAdService: To handle OIM's request and response for user provisioning and de-provisioning services. This web service requires FCUBS Gateway EJB either on same Weblogic Application server or another. If it is on same Weblogic Application server then this web service is deployed as child of Gateway EJB.

OIM FCUBS adapter setup is all about deployment of these web services on Oracle Fusion Middleware 11g Release 2 (11.1.2.2.0).

### 5.1.4.1 Environment Setup

The following steps to be followed to do the initial environment setup for OIM FCUBS adapter deployment:

1. Copy following folders from the Kernel Vercon Software Release area
  - <FCUBS Release Name>\ADAPTERS\OIM\FCUBSLOVAdService
  - <FCUBS Release Name>\ADAPTERS\OIM\FCUBSProvisioningAdService
  - <FCUBS Release Name>\ADAPTERS\OIM\setup

to local machine (say **D:\OIM** for WINDOWS or **/home/kernel/OIM** for UNIX).

Note: If Gateway EJB server and OIM server is on same system, then copy entire folder from Kernel VERCON software release area to local machine.

In this document SPMLADAPTER\_INSTALL\_DIR specifies the directory where adapter will be installed.

e.g.

For WINDOWS:

SPMLADAPTER\_INSTALL\_DIR=D:\

For UNIX:

SPMLADAPTER\_INSTALL\_DIR=/home/kernel/

OIM\_SERVER\_INSTALL\_DIR specifies the OIM server installation directory (like D:\Oracle\Middleware\weblogic\Oracle\_IDM1 in windows or /Oracle/Middleware/weblogic/ Oracle\_IDM1 in unix).

2. Create a Data source in WebLogic Server Version: 10.3.6.0.

[\[Refer Appendix 8.1 Data Source Creation\]](#)

3. Modify configuration files as below :

Edit **<SPMLADAPTER\_INSTALL\_DIR>\OIM\FCUBSLOVAdService\src\webcontent\WEB-INF\web.xml**. This XML file shall have a similar section as the one shown below (Change the values given in bold)

```
<resource-ref>
    <res-ref-name>OIMLOVSQA</res-ref-name>
    <res-type>javax.sql.DataSource</res-type>
    <res-auth>Container</res-auth>
</resource-ref>
```

```

<env-entry>
    <description>Property File Path</description>
    <env-entry-name>propertyPath</env-entry-name>
    <env-entry-type>java.lang.String</env-entry-type>
    <env-entry-value>D:/OIM/FCUBSLOVAdService/config/</env-entry-value>
</env-entry>

```

**Edit resource-ref section:** Mention the JNDI name of the Datasource created in Application server for FLEXCUBE UBS Messaging Database Layer Instance at step 3 as res-ref-name.

**Edit Property File Path:** Give the absolute path for lookup\_prop.xml as env-entry-value. Ideally, this file is residing in <SPMLADAPTER\_INSTALL\_DIR>\OIM\FCUBSLOVAdService\config.

Note: Give "/" for at the end of the path. Also, note that as separator forward slash has been used instead of backward.

Edit <SPMLADAPTER\_INSTALL\_DIR>\OIM\FCUBSLOVAdService\config\lookup\_prop.xml. This XML file shall have a similar section as the one shown below, (Change the values given in bold)

```

<!-- DataBase Connection -->
    <add key="FCUBS_CON_POOLNAME" value="OIMLOVSQA"/>
<!-- DataBase Connection -->
<add key="LOGGER_PATH"
value="D:/OIM/FCUBSLOVAdService/config/lookup_logger.xml"/>

```

**Edit FCUBS\_CON\_POOLNAME:** Give the same Datasource JNDI name mentioned in above web.xml for FLEXCUBE UBS Messaging Database Layer Instance.

**Edit LOGGER\_PATH:** Give the logging configuration absolute path for lookup\_logger.xml. This file is residing in <SPMLADAPTER\_INSTALL\_DIR>\OIM\FCUBSLOVAdService\config folder.

**Note:** As separator use forward slash instead of backward slash.

Edit <SPMLADAPTER\_INSTALL\_DIR>\OIM\FCUBSLOVAdService\config\lookup\_logger.xml. This XML file shall have a similar section as the one shown below, (Change the values given in bold)

```

<add key="ADOIM.LOGGER.FPATH" value="D:/OIM/FCUBSLOVAdService/log/" />

```

ADOIM.LOGGER.FPATH: Give the absolute path where log files will be stored. It is recommended that mention the following path <SPMLADAPTER\_INSTALL\_DIR>\OIM\FCUBSLOVAdService\log/

Note: As separator use forward slash instead of backward slash. Give "/" for at the end of the path.

Edit <SPMLADAPTER\_INSTALL\_DIR>\OIM\FCUBSProvisioningAdService\src\webcontent\WEB-INF\web.xml. This XML file shall have a similar section as the one shown below (Change the values given in bold)

```

<ejb-ref>
    <ejb-ref-name>GWEJB_GW_EJB_Bean</ejb-ref-name>
    <ejb-ref-type>Session</ejb-ref-type>
    <home>com.iflex.fcubs.gw.ejb.GWEJBRemoteHome</home>
    <remote>com.iflex.fcubs.gw.ejb.GWEJBRemote</remote>
</ejb-ref>
<env-entry>
    <description>Property File Path</description>
    <env-entry-name>propertyPath</env-entry-name>
    <env-entry-type>java.lang.String</env-entry-type>
    <env-entry-value>D:/OIM/FCUBSProvisioningAdService/config/</env-
entry-value>
</env-entry>

```

**Edit ejb-link:** To refer Gateway EJB from the web service locally the reference of Gateway EJB has been defined in this deployment descriptor file. Give the Gateway EJB name here as ejb-link, mentioned as ejb-name in ejb-jar.xml deployment descriptor file of Gateway EJB.

**Edit Property File Path:** Give the absolute path for ADOIM\_Prop.xml as env-entry-value. This file is residing in **<SPMLADAPTER\_INSTALL\_DIR>\OIM\FCUBSProvisioningAdService\config**.

**Note: Give "/" for at the end of the path. Also, note that as separator forward slash has been used instead of backward.**

Edit **<SPMLADAPTER\_INSTALL\_DIR>\OIM\FCUBSLOVAdService\config\ADOIM\_Prop.xml**. This XML file shall have a similar section as the one shown below, (Change the values given in bold)

```

<add key="GW_EJB_JNDI_NAME" value="GWEJB/ejb/GW_EJB_Bean"/>
<add key="GW_EJB_CALL_TYPE" value="REMOTE"/>
<add key="GW_EJB_CTX_FACTORY"
value="weblogic.jndi.WLInitialContextFactory"/>
<add key="GW_EJB_SERVER_URL" value="t3://localhost:7101"/>
<add key="GW_EJB_SECURITY_PRINCIPAL" value=""/>
<add key="GW_EJB_SECURITY_CREDENTIALS" value=""/>

```

Edit **GW\_EJB\_JNDI\_NAME**: Give the Gateway EJB JNDI name.

Edit GW\_EJB\_CALL\_TYPE: Give the LOCAL or REMOTE (must be in Upper Case) based on the way EJB is to be referred from web service. If FCUBS Gateway EJB is deployed on same Weblogic Application server then it should be REMOTE.

Edit GW\_EJB\_SERVER\_URL: Give the application server URL where Gateway EJB is deployed.

Following are the parts that make this URL:

t3s://HOSTNAME:Port/GW\_EJB\_Bean



Protocol Host Name Weblogic Port EJB Name

**Protocol:** This should be t3 as in WebLogic application server.

**Server URL:** This should be the IP address or fully qualified computer name (i.e. <computer name>.<domain>) of the system where the application server is running on which Gateway EJB has been deployed.

**Port:** This should be the same as **request port** mentioned in domain.xml file.

**EJB Name:** This should be the name of the Gateway EJB name (given in ejb-jar.xml as ejb-name tag value).

Edit following section in the <SPMLADAPTER\_INSTALL\_DIR>\OIM\FCUBSLOVAdService\config\ADOIM\_Prop.xml file: (Change the values given in bold )

```
<add key="MAKER_ID" value="OIMUSER9" />
<add key="HEAD_OFFICE" value="CHO" />
<add key="REQ_SOURCE" value="IDM" />
<add key="UBS_OR_IS" value="FCUBS" />

<add key="LOGGER_PATH"
value="D:/OIM/FCUBSProvisioningAdService/config/adoim_logger.xml" />
<add key="FCUBS_SPML_ERROR_FILE"
value="D:/OIM/FCUBSProvisioningAdService/config/
FCUBS_SPML_ERROR.properties" />
<add key="ADOIM_MSG_LOGGING_ENABLED" value="N" />
<add key="ADOIM_MSG_LOGGING_PATH"
value="D:/OIM/FCUBSProvisioningAdService/log" />
```

**Edit MAKER\_ID:** Give FCUBS user id that can serve as maker id for all OIM requests. Please ensure that this id should be a valid user in FCUBS and should have rights for creating, authorizing and modifying user.

**Edit HEAD\_OFFICE:** Give the head office branch code.

**Edit REQ\_SOURCE:** Give the external source name. Please ensure that maintenance of this external source has been done in FCUBS.

**Edit UBS\_OR\_IS:** Give the application name to which the user need to be provisioned. The value will be either FCUBS or FCIS.

**Edit LOGGER\_PATH:** Give the logging configuration absolute path for adoim\_logger.xml. This file is residing in <SPMLADAPTER\_INSTALL\_DIR>\OIM\FCUBSProvisioningAdService\config folder.

**Edit FCUBS\_SPML\_ERROR\_FILE:** Give the absolute path for fcubs\_spml\_error.properties. This file is residing in < SPMLADAPTER\_INSTALL\_DIR>\OIM\FCUBSProvisioningAdService\config folder.

**Edit ADOIM\_MSG\_LOGGING\_ENABLED:** Give 'Y' if OIM request and response message is required to be stored separately otherwise give 'N'.

**Edit ADOIM\_MSG\_LOGGING\_PATH:** Give the absolute path where OIM request–response will get stored.

Note: As separator use forward slash instead of backward slash. Give "/" for at the end of the path.

Edit <SPMLADAPTER\_INSTALL\_DIR>\OIM\FCUBSProvisioningAdService\config\adoim\_logger.xml. This XML file shall have a similar section as the one shown below, (Change the values given in bold)

```
<add key="ADOIM.LOGGER.FPATH" value="D:/OIM/FCUBSProvisioningAdService /log/" />
```

**Edit ADOIM.LOGGER.FPATH:** Give the absolute path where log files will be stored. It is recommended that mention the following path <SPMLADAPTER\_INSTALL\_DIR>/OIM/FCUBSProvisioningAdService/log/

Note: As separator use forward slash instead of backward slash. Give "/" for at the end of the path.

### 5.1.4.1.1 Building the Deployment Units for WINDOWS

#### 1. Building FCUBSLOVAdService.ear

- Edit <SPMLADAPTER\_INSTALL\_DIR>\OIM\FCUBSLOVAdService\setup\WEBLOGIC\ build.xml to set {server\_home} entry to Weblogic Server installed directory  
Eg: D:\Middleware\wlserver\_10.3
- Open a DOS command-prompt and change directory to, D:\OIM\FCUBSLOVAdService\
- Set PATH to JDK\bin and ANT\bin in the command prompt
- Set JAVA\_HOME
- Change the directory to D:\OIM\FCUBSLOVAdService\setup\WEBLOGIC
- To execute the build file, type "ant" on the command-prompt and press enter.

Above step creates an EAR file in D:\OIM\FCUBSLOVAdService\build with the name FCUBSLOVAdService.ear

#### 2. Building FCUBSProvisioningAdService.ear

- Edit <SPMLADAPTER\_INSTALL\_DIR>\OIM\FCUBSProvisioningAdService\setup\WEBLOGIC\build.xml to set {server\_home} and {JAVA\_HOME} entry to Weblogic Server installed directory and JDK Installed directory.

Eg: D:\Middleware\wlserver\_10.3

C:\Program Files\java\jdk1.7.0\_51

- Change directory to, D:\OIM\FCUBSProvisioningAdService\setup\WEBLOGIC
- To execute the build file, type “ant” on the command-prompt and press enter.

Above step creates an EAR file in build D:\OIM\FCUBSProvisioningAdService folder with the name FCUBSProvisioningAdService.ear

### 5.1.4.1.2 Building the Deployment Units for UNIX / Linux

#### 1. Building FCUBSLOVAdService.ear

- Modify {server\_home} entry in the build.xml to where Weblogic Server is installed ( for example /home/kernel/Middleware/wlserver\_10.3 )
- Open a UNIX shell prompt and change directory to, /home/OIM/FCUBSLOVAdService
- Set PATH environment variable with JDK/bin path and ANT\bin path in the command prompt.
- Change the directory to <SPMLADAPTER\_INSTALL\_DIR>/FCUBSLOVAdService/setup/WEBLOGIC
- To execute the build file, type “ant” on the shell prompt and press enter.

Above step creates an EAR file in /home/kernel/OIM/FCUBSLOVAdService/build folder with the name FCUBSLOVAdService.ear

#### 2. Building FCUBSProvisioningAdService.ear

- Edit <SPMLADAPTER\_INSTALL\_DIR>/OIM/FCUBSProvisioningAdService/setup/WEBLOGIC/build.xml to set {server\_home} entry to Weblogic Server installed directory

Eg: home/Oracle/Middleware/wlserver\_10.3

home/java/jdk1.7.0\_51

- Change directory to, /home/kernel/OIM/FCUBSProvisioningAdService/setup/WEBLOGIC
- To execute the build file, type “ant” on the command-prompt and press enter.

Above step creates an EAR file in /home/kernel/OIM/FCUBSProvisioningAdService/build folder with the name FCUBSProvisioningAdService.ear

## 5.1.4.2 Deployment

### Deploy FCUBSLOVAdService

1. Login to Administrative Console
2. Enter Weblogic administrator username/password and press **Login**.



3. Click on Deployments as shown in below screen.

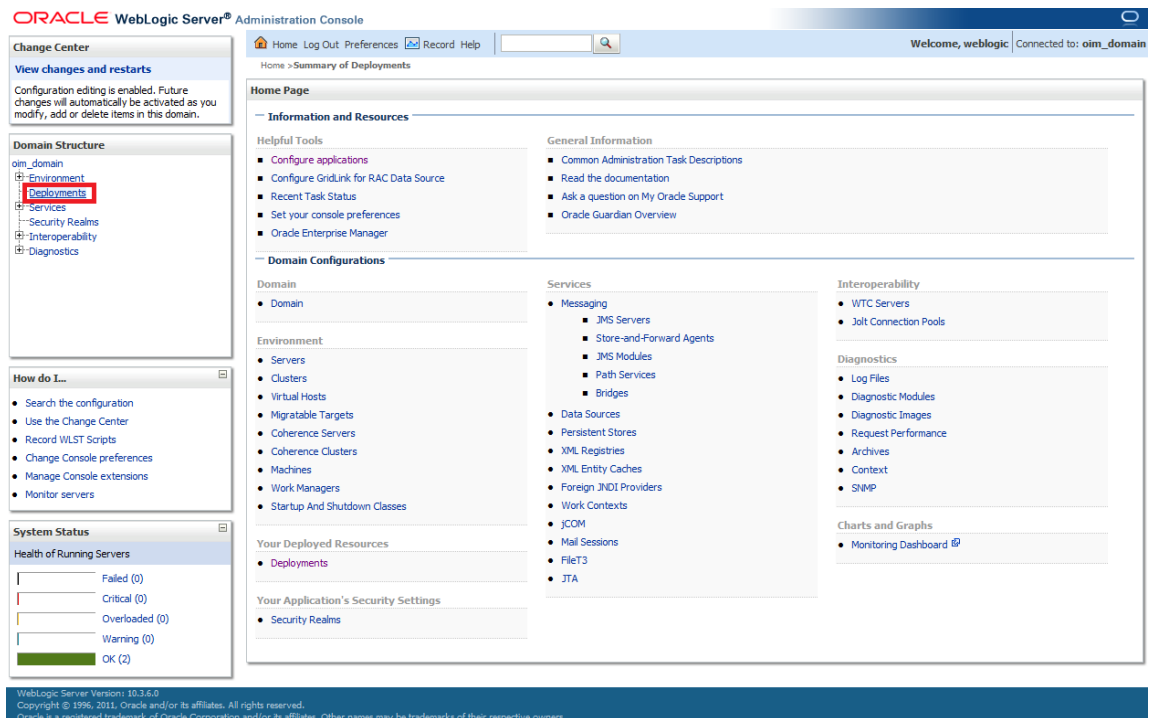



4. Click on the Install as shown below.

The screenshot shows the Oracle WebLogic Server Administration Console. The main content area is titled "Summary of Deployments" and contains a table of installed applications. The "Install" button at the top left of the table is highlighted with a red box. The table lists various applications and their deployment order.

Name	State	Health	Type	Deployment Order
adf.oracle.businesseditor(1.0,11.1.1.2.0)	Active		Library	100
adf.oracle.domain(1.0,11.1.1.2.0)	Active		Library	100
adf.oracle.domain.webapp(1.0,11.1.1.2.0)	Active		Library	100
AqAdapter	Active	OK	Resource Adapter	324
ibZui	Active	OK	Enterprise Application	313
composer	Active	OK	Enterprise Application	315
DbAdapter	Active	OK	Resource Adapter	322
DefaultToDoTaskFlow	Active	OK	Enterprise Application	314
DMS Application (1.1.1.1.1.0)	Active	OK	Web Application	5
em	Active	OK	Enterprise Application	400

5. The following screen is displayed.

6. Click on upload your file(s)

The screenshot shows the "Install Application Assistant" dialog box. The "Path:" field is populated with the path: /scratch/app/sso1123/wl1036/NMiddleware/user\_projects/domains/oim\_domain. The "upload your file(s)" text in the note is highlighted with a red box.

**Note:** Only valid file paths are displayed below. If you cannot find your deployment files, **upload your file(s)** and/or confirm that your application contains the required deployment descriptors.

7. Choose the enterprise archive file from the build path:

<SPMLADAPTER\_INSTALL\_DIR>\OIM\FCUBSLOVAdService\build\

8. Click on Next

The screenshot shows the Oracle WebLogic Server Administration Console. On the left, there are panels for 'Change Center', 'Domain Structure', 'How do I...', and 'System Status'. The main area displays the 'Install Application Assistant' dialog. The 'Deployment Archive' field is highlighted with a red box and contains the path: <SPMLADAPTER\_INSTALL\_DIR>\OIM\FCUBSLOVAdService\build\FCUBSLOVAdService.ear. The 'Next' button is also highlighted with a red box.

9. Select the enterprises archive file FCUBSLOVAdService.ear

10. Click on Next

The screenshot shows the Oracle WebLogic Server Administration Console. On the left, there are panels for 'Change Center', 'Domain Structure', 'How do I...', and 'System Status'. The main area displays the 'Install Application Assistant' dialog. The 'Path' field is highlighted with a red box and contains the path: /scratch/app/sso1123/wl1036/NMiddleware/user\_projects/domains/oim\_domain/servers/AdminServer/upload/FCUBSLOVAdService.ear. The 'Next' button is also highlighted with a red box.



11. The following screen is displayed.
12. Select – Install this deployment as an application.
13. Click on Next.

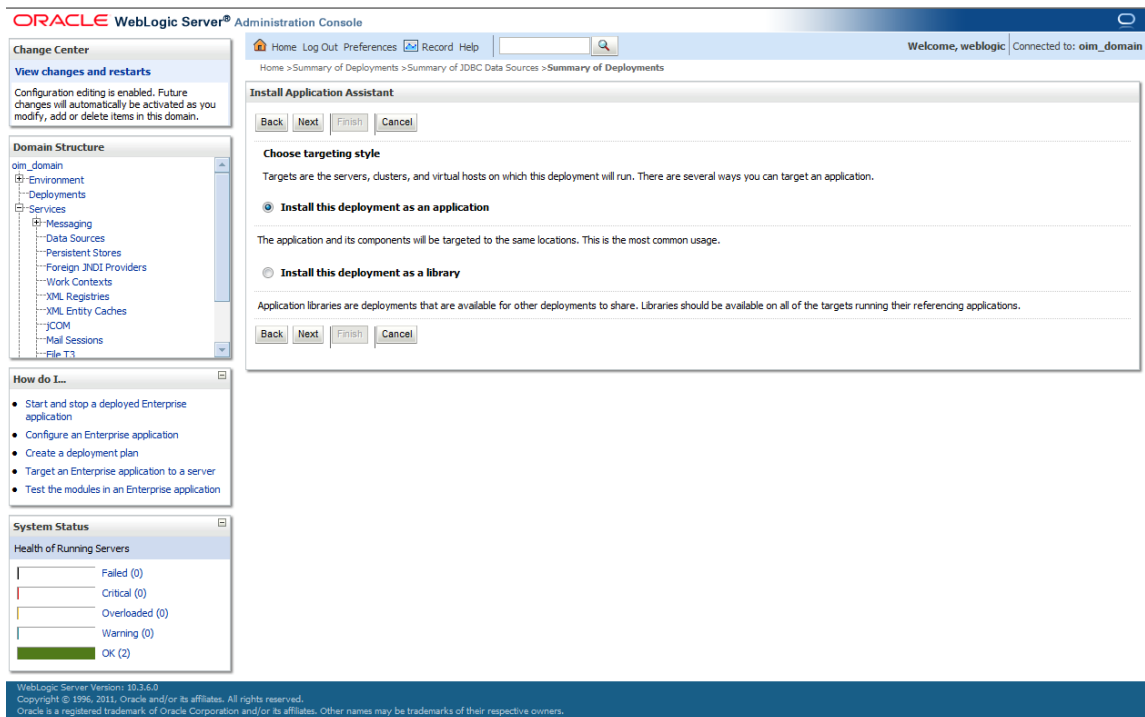

14. The following screen is displayed.
15. Select the Application Server Instance in which the FCUBSLOVAdService needs to be deployed.
16. Click on Next.

ORACLE WebLogic Server® Administration Console

Home Log Out Preferences Record Help Welcome, weblogic Connected to: oim\_domain

Change Center  
View changes and restarts  
Configuration editing is enabled. Future changes will automatically be activated as you modify, add or delete items in this domain.

Domain Structure  
oim\_domain  
- Environment  
- Deployments  
- Services  
- Messaging  
- Data Sources  
- Persistent Stores  
- Foreign JNDI Providers  
- Work Contexts  
- XML Registries  
- XML Entity Caches  
- JCOM  
- Mail Sessions  
- File T3

How do I...  
• Start and stop a deployed Enterprise application  
• Configure an Enterprise application  
• Create a deployment plan  
• Target an Enterprise application to a server  
• Test the modules in an Enterprise application

System Status  
Health of Running Servers  
Failed (0)  
Critical (0)  
Overloaded (0)  
Warning (0)  
OK (2)

Install Application Assistant  
Back Next Finish Cancel  
Select deployment targets  
Select the servers and/or clusters to which you want to deploy this application. (You can reconfigure deployment targets later).  
Available targets for FCUBSLOVAdService :  
Servers  

<input type="checkbox"/>	AdminServer
<input checked="" type="checkbox"/>	oim_server1
<input type="checkbox"/>	soa_server1

  
Back Next Finish Cancel

WebLogic Server® Version: 10.3.6.0  
Copyright © 1996, 2011, Oracle and/or its affiliates. All rights reserved.  
Oracle is a registered trademark of Oracle Corporation and/or its affiliates. Other names may be trademarks of their respective owners.

17. The following screen is displayed.

18. Click on Finish.

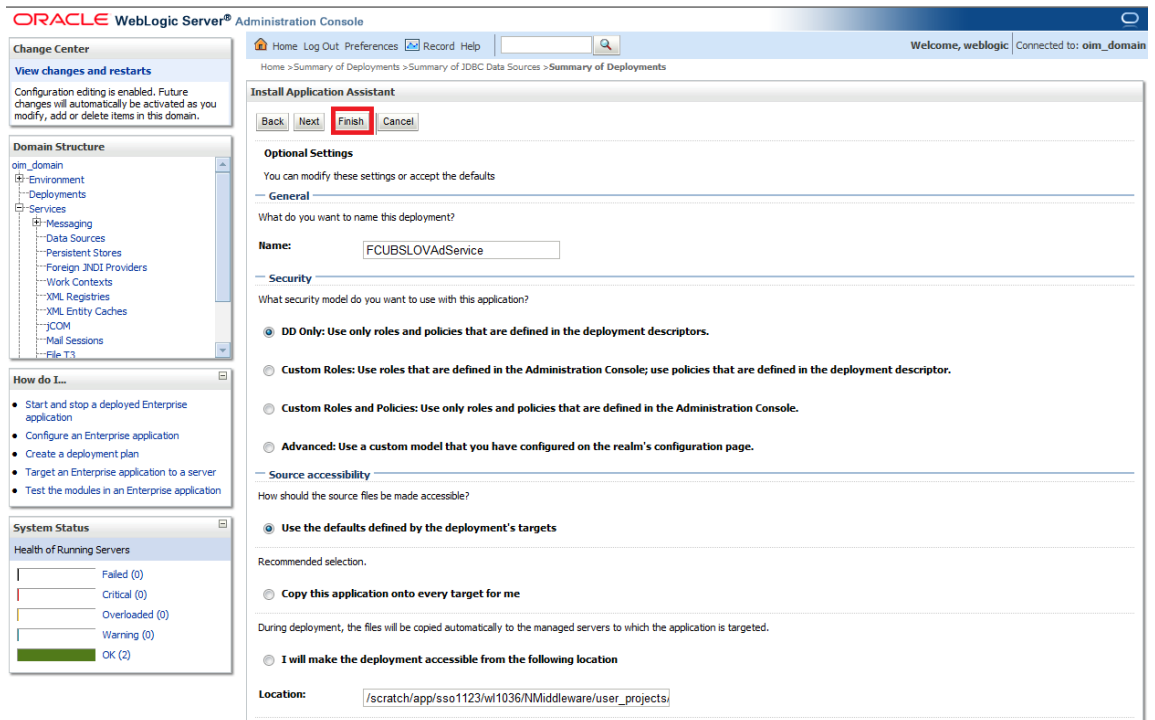

### 5.1.4.2.1 Deploy FCUBSProvisioningAdService

If the **GW\_EJB\_CALL\_TYPE** is set as **REMOTE** in the **ADOIM\_Prop.xml** then follow the same step as above (Section 5.1.4.2.1) to deploy the FCUBSProvisioningAdService web service with following changes

- Select the ear file from the path <SPMLADAPTER\_INSTALL\_DIR>\OIM\FCUBSProvisioningAdService\build\FCUBSProvisioningAdService.ear
- Give the application name as FCUBSProvisioningAdService.

If the **GW\_EJB\_CALL\_TYPE** is set as **REMOTE** in the **ADOIM\_Prop.xml**, follow the below steps

The following screen is displayed.

1. Make sure that Gateway EJB bean has been deployed there as shown in below screen shot.

**ORACLE WebLogic Server® Administration Console**

Home Log Out Preferences Record Help Welcome, weblogic Connected to: oim\_domain

Home > Summary of Deployments > Summary of JDBC Data Sources > Summary of Deployments > GWEJB > Summary of Deployments > GWEJB > Summary of JDBC Data Sources > Summary of Deployments

### Summary of Deployments

Control Monitoring

This page displays a list of Java EE applications and stand-alone application modules that have been installed to this domain. Installed applications and modules can be started, stopped, updated (redeployed), or deleted from the domain by first selecting the application name and using the controls on this page.

To install a new application or module for deployment to targets in this domain, click the Install button.

Customize this table

#### Deployments

Showing 11 to 20 of 92 Previous Next

Name	State	Health	Type	Deployment Order
email	Active		Library	100
emas	Active		Library	100
emcore	Active		Library	100
FCUBSLOVAdService	Active	OK	Enterprise Application	100
FileAdapter	Active	OK	Resource Adapter	321
FMW Welcome Page Application (11.1.0.0.0)	Active	OK	Enterprise Application	5
FtpAdapter	Active	OK	Resource Adapter	325
<b>GWEJB</b>	Active	OK	Enterprise Application	100
Modules				
GW_EJB_Bean.jar			EJB Module	
EJBs				
GWEJB_GW_EJB_Bean			EJB	
Web Services				
None to display				

Refer 5.1.4.2.1 to know more about the deployment steps.

2. Choose the enterprise archive file Path from the build path:

<SPMLADAPTER\_INSTALL\_DIR>\OIM\FCUBSProvisioningAdService\build\

3. Select the enterprises archive file FCUBSProvisioningAdService.ear

4. Click on Finish.

**ORACLE WebLogic Server® Administration Console**

Home Log Out Preferences Record Help Welcome, weblogic Connected to: oim\_domain

Home > Summary of Deployments > Summary of JDBC Data Sources > Summary of Deployments > GWEJB > Summary of Deployments > GWEJB > Summary of JDBC Data Sources > Summary of Deployments

### Install Application Assistant

Back Next **Finish** Cancel

**Optional Settings**

You can modify these settings or accept the defaults

**General**

What do you want to name this deployment?

**Name:** FCUBSProvisioningAdService

**Security**

What security model do you want to use with this application?

**DD Only:** Use only roles and policies that are defined in the deployment descriptors.

**Custom Roles:** Use roles that are defined in the Administration Console; use policies that are defined in the deployment descriptor.

**Custom Roles and Policies:** Use only roles and policies that are defined in the Administration Console.

**Advanced:** Use a custom model that you have configured on the realm's configuration page.

**Source accessibility**

How should the source files be made accessible?

**Use the defaults defined by the deployment's targets**

Recommended selection:

**Copy this application onto every target for me**

During deployment, the files will be copied automatically to the managed servers to which the application is targeted.

**I will make the deployment accessible from the following location**

**Location:** /scratch/app/sso1123/wl1036/NMiddleware/user\_projects

## 5.1.5 OIM Setup

**Prerequisite:** Oracle Identity Server & Oracle Design Console.

OIM side setup should be done on the system where OIM server is running. This setup includes

Java code deployment of OIM's pre-populate adapter, entity adapter and schedule task & importing integration specific configuration files into OIM.

The following steps to be followed to do the initial environment setup:

1. Copy following folders from the Kernel Vercon Software Release area

- <FCUBS Release Name>\ADAPTERS\OIM\OIM-Config
- <FCUBS RELEASE NAME>\ADAPTERS\OIM\setup

to local machine (say D:\OIM for WINDOWS or /home/kernel/OIM for UNIX).

2. Building the Lookup Search Scheduled Task deployment units for WINDOWS.

- Change directory to, D:\OIM\OIM-Config\Sch-Task\setup
- Modify the OIM\_SERVER\_INSTALL\_DIR entry in the build.xml to where OIM Server is installed ( for example D:\Oracle\Middleware\weblogic\Oracle\_IDM1) and JAVA\_HOME entry.
- In the below section of build.xml change the WSDL location hostname and port.

```
<exec executable="{JAVA_HOME}/bin/wsimport">  
  
<arg line="-keep -p com.iflex.fcubs.integration.oim.ws.client http://  
<hostname>:<port>/FCUBSLOVAdService/FCUBSLOVAdServiceSEI?WSDL"/>  
  
</exec>
```

- To execute the build file, type “ant” on the command-prompt and press enter.

Above step creates a JAR file in D:\OIM\OIM-Config\Sch-Task\build\ FCUBSLOV SchTask folder with the name **FCUBSLOV SchTask.Jar**

- Copy this FCUBSLOV SchTask.Jar to the <OIM\_SERVER\_INSTALL\_DIR>\server\ScheduleTask folder and <OIM\_SERVER\_INSTALL\_DIR>\server\apps\oim.ear\APP-INF\lib

3. Building the Lookup Search Scheduled Task deployment units for UNIX

- Change directory to /home/kernel/OIM/OIM-Config/Sch-Task/setup
- Modify the OIM\_SERVER\_INSTALL\_DIR entry in the build.xml to where OIM Server is installed ( for example /Oracle/Middleware/weblogic/Oracle\_IDM1 ) and JAVA\_HOME entry.
- In the below section of build.xml change the WSDL location hostname and port.

```
<exec executable="{JAVA_HOME}/bin/wsimport">  
  
<arg line="-keep -p com.iflex.fcubs.integration.oim.ws.client  
http://<hostname>:<port>/FCUBSLOVAdService/FCUBSLOVAdServiceSEI?WSDL"/>  
  
</exec>
```

- To execute the build file, type “ant” on the shell and press enter.



Above step creates a JAR file in /home/kernel/OIM/OIM-Config/Sch-Task/build/FCUBSLOVSchTask folder with the name **FCUBSLOVSchTask.Jar**

- Copy this FCUBSLOVSchTask.Jar to the <OIM\_SERVER\_INSTALL\_DIR>/server/ScheduleTask folder and <OIM\_SERVER\_INSTALL\_DIR>/server/apps/oim.ear/APP-INF/lib

#### 4. Deployment of Pre-population Adapters

Below Steps will be valid In case of different name used to create the form in [5.1.5.1.5.28](#)

- Change the directory to

<AdapterSource>/OIM/OIM-Config/PrePopulateAdapter

- Edit the plugin.xml and update the FlexcubeForm into the form name entered in [5.1.5.1.5.28](#)

```
<?xml version="1.0" encoding="UTF-8" ?>

<oimplugins xmlns:xsi="http://www.w3.org/2001/XMLSchema-instance">

<plugins pluginpoint="oracle.iam.request.plugins.PrePopulationAdapter">

<plugin pluginclass="com.oracle.oim.utility.eventhandler.UserIDPrepopulateAdapter" version="1.0"

        name="UserIDPrepopulateAdapter">

<metadata name="PrePopulationAdapater">

<value>FlexcubeForm::USERID</value>

</metadata>

</plugin>

<plugin pluginclass="com.oracle.oim.utility.eventhandler.UserNamePrepopulateAdapter" version="1.0"

        name="UserNamePrepopulateAdapter">

<metadata name="PrePopulationAdapater">

<value>FlexcubeForm::USERNAME</value>

</metadata>

</plugin>

<plugin pluginclass="com.oracle.oim.utility.eventhandler.UserPasswordPrepopulateAdapter" version="1.0"

        name="UserPasswordPrepopulateAdapter">

<metadata name="PrePopulationAdapater">

<value>FlexcubeForm::USERPASSWORD</value>

</metadata>

</plugin>

<plugin pluginclass="com.oracle.oim.utility.eventhandler.EmailPrepopulateAdapter" version="1.0"

        name="EmailPrepopulateAdapter">

<metadata name="PrePopulationAdapater">
```

```

    <value>FlexcubeForm::EMAIL</value>

</metadata>

</plugin>

<plugin pluginclass="com.oracle.oidm.utility.eventhandler.LdapUserPrepopulateAdapter" version="1.0"
        name="LdapUserPrepopulateAdapter">
    <metadata name="PrePopulationAdapter">
        <value>FlexcubeForm::LDAPUSR</value>
    </metadata>
</plugin>

<plugin pluginclass="com.oracle.oidm.utility.eventhandler.StartDatePrepopulateAdapter" version="1.0"
        name="StartDatePrepopulateAdapter">
    <metadata name="PrePopulationAdapter">
        <value>FlexcubeForm::STARTDATE</value>
    </metadata>
</plugin>
</plugins>

<plugins pluginpoint="oracle.iam.platform.kernel.spi.EventHandler">

    <plugin pluginclass="com.oracle.oidm.utility.eventhandler.UserPasswordPreProcessHandler" version="1.0"
            name="UserPasswordPreProcessHandler"></plugin>
</plugins>
</oimplugins>

```

- Change the directory to
 

```
<AdapterSource>/OIM/OIM-Config/PrePopulateAdapter /setup
```
- Modify the OIM\_SERVER\_INSTALL\_DIR entry in the build.xml to where OIM Server is installed (for example D:\Oracle\Middleware\weblogic\Oracle\_IDM1) and JAVA\_HOME entry
  - To execute the build file, type “ant” on the shell and press enter.

Above step creates a zip file in <AdapterSource>/OIM/OIM-Config/PrePopulateAdapter/build/ folder with the name **prepopulateadapter.zip**

- Copy the <AdapterSource>/OIM/OIM-Config/PrePopulateAdapter/build/prepopulateadapter.zip into <OIM\_SERVER\_INSTALL\_DIR>/server/plugins/
- <OIM\_SERVER\_INSTALL\_DIR>/server/plugin\_utility/ant.properties should be changed from

```

#####

## The installation directory for WLS or WAS

#####

```

```

#wls.home=@wls_home

#was.home=@was_home

#####

# The OIM server directory for OIM. For example: MW_HOME/Oracle_IDM1/server
#####

#oim.home@oim_home

#####

#login file name with path for WAS or WLS
#####

#login.config=${oim.home}/config/authwl.conf
#login.config=${oim.home}/config/authws.conf

#####

# Represents the directory where Oracle Fusion Middleware is installed.
#####

#mw.home=@mw_home

```

To

```

#####

## The installation directory for WLS or WAS
#####

wls.home=<Installation_DIR>/Middleware/wlserver_10.3

#was.home=@was_home

#####

# The OIM server directory for OIM. For example: MW_HOME/Oracle_IDM1/server
#####

oim.home=<OIM_INSTALLATION_DIR>/server/

#####

#login file name with path for WAS or WLS

```

```
#####

login.config=${oim.home}/config/authwl.conf

#login.config=${oim.home}/config/authws.conf

#####

# Represents the directory where Oracle Fusion Middleware is installed.

#####

mw.home=<Installation_DIR>/Middleware
```

- Set the ANT\_HOME & JAVA\_HOME
  - In Command Prompt / SHELL type the below command and Press Enter
  - ant -f pluginregistration.xml register
  - Following Information has to be provided
    - > OIM Admin User – xelsysadm
    - > OIM Admin User – Password
    - > OIM Admin server URL : t3://hostname:portname
    - > Full path of adapter which needs to be imported
- <OIM\_SERVER\_INSTALL\_DIR>/server/plugins/prepopulateadapter.zip
- Result will be displayed like

Plugin com.oracle.oim.utility.eventhandler.LdapUserPrepopulateAdapter version 1.0 Registered

Plugin com.oracle.oim.utility.eventhandler.UserIDPrepopulateAdapter version 1.0 Registered

Plugin com.oracle.oim.utility.eventhandler.StartDatePrepopulateAdapter version 1.0 Registered

Plugin com.oracle.oim.utility.eventhandler.UserNamePrepopulateAdapter version 1.0 Registered

Plugin com.oracle.oim.utility.eventhandler.UserPasswordPrepopulateadapter version 1.0 Registered

Plugin com.oracle.oim.utility.eventhandler.EmailPrepopulateAdapter version 1.0 Registered

Plugin com.oracle.oim.utility.eventhandler.UserPasswordPreProcessHandler version 1.0 Registered

- Modify the weblogic.properties under < OIM\_SERVER\_INSTALL\_DIR >/server/bin

```
wls_servername=@servername

application_name=@appname

metadata_from_loc=@metadata_from_loc
```

to

```
wls_servername=oim_server1

application_name=OIMMetadata

metadata_from_loc=<AdapterSource>/OIM/OIM-Config/PrePopulateAdapter/oim
```

- Type **sh weblogicImportMetadata.sh** in shell or **weblogicImportMetaData.bat** in command prompt and press enter to execute the command.
- You have to enter Weblogic Admin Server – user name, password and URL ( like t3://localhost:7001 )
- Type **sh PurgeCache.sh all** in shell or **PurgeCache.bat all** in command prompt and press enter to execute the command.
- Now you have to enter oim admin user name ( xelsysadm ), password and oim server URL ( like t3://localhost:14000 )
- Restart the OIM Server to impact the changes done.

#### 5. Create folders for Reconciliation

- For reconciliation, there should be different folder for staging files (yet to be reconciled) and for processed files (after reconciliation). These folders can be anywhere that OIM should be able to access. If it is other than the OIM server system then that network path should be mapped as network drive.
- Create folder to keep staging file, for example

<OIM\_SERVER\_INSTALL\_DIR>\xellerate\GTC\Recon\Staging

- Create folder to keep processed file, for example

<OIM\_SERVER\_INSTALL\_DIR>\xellerate\GTC\Recon\Archive

#### 6. Importing Configuration Files

This step involves import of integration specific configuration files into OIM using OIM provided Deployment Manager.

Prerequisite: Ensure that OIM setup steps have been followed properly.

Note: Do the import in the same order as it is described below.

Open the Oracle Identity Manager Administrative console. (Give the following URL in the browser: <http://<hostname>:<oimport>/sysadmin>)

#### 7. Login to Administrative Console

#### 8. Enter OIM administrator username/password and press Sign In.

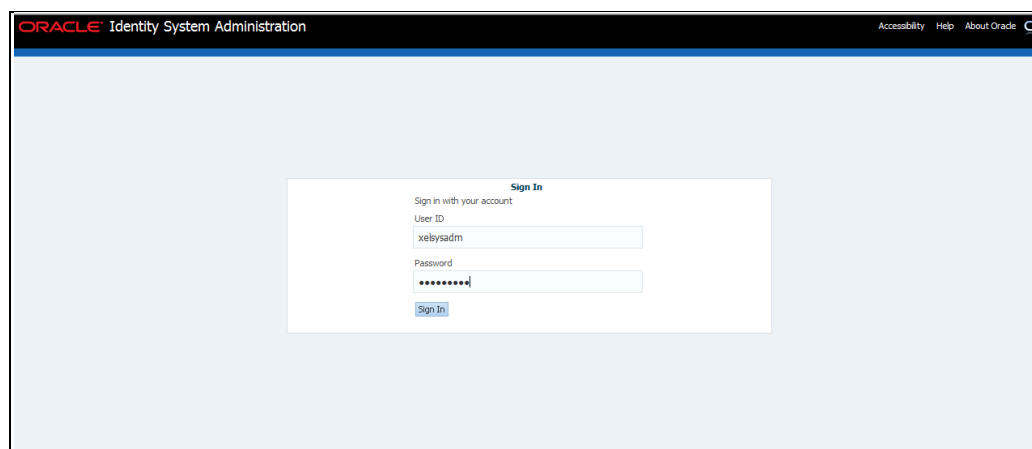

9. Click on Import option under System Management.

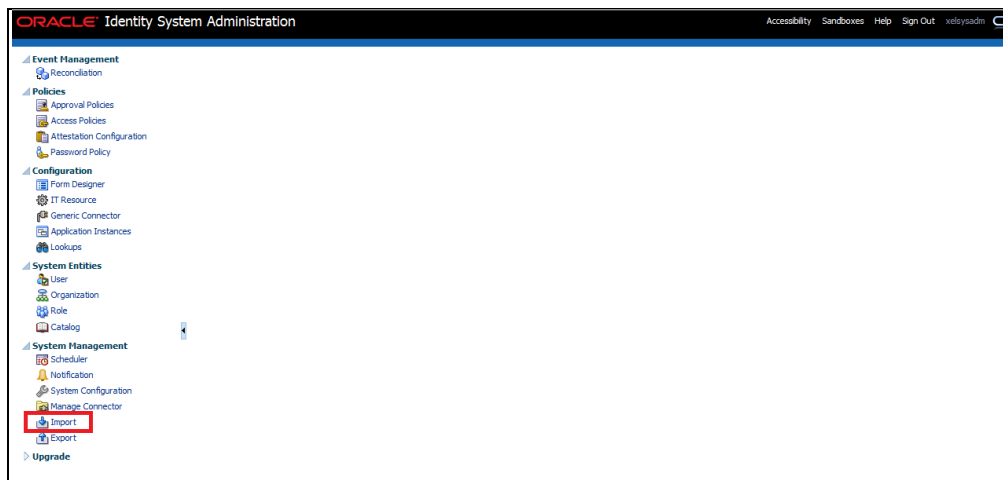

The following screen will get displayed with Add File option.

10. Select Lookup.xml file from the folder <SPMLADAPTER\_INSTALL\_DIR>\OIM\OIM-Config\Screens-Config.

11. Click on Open.

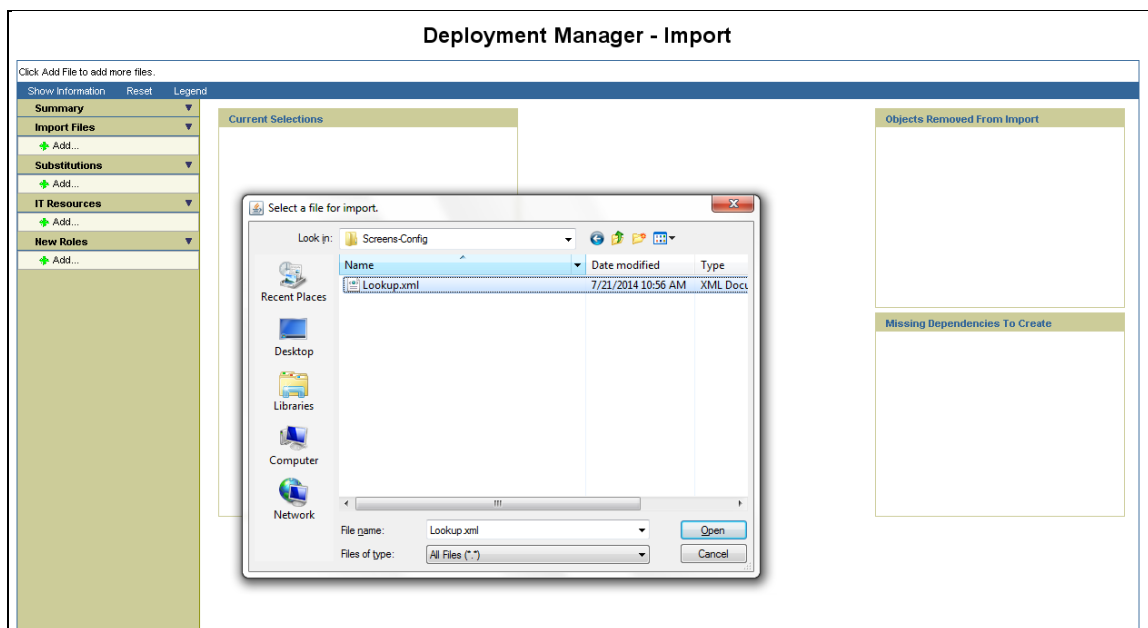

We will get File preview screen

12. Click on Add file.

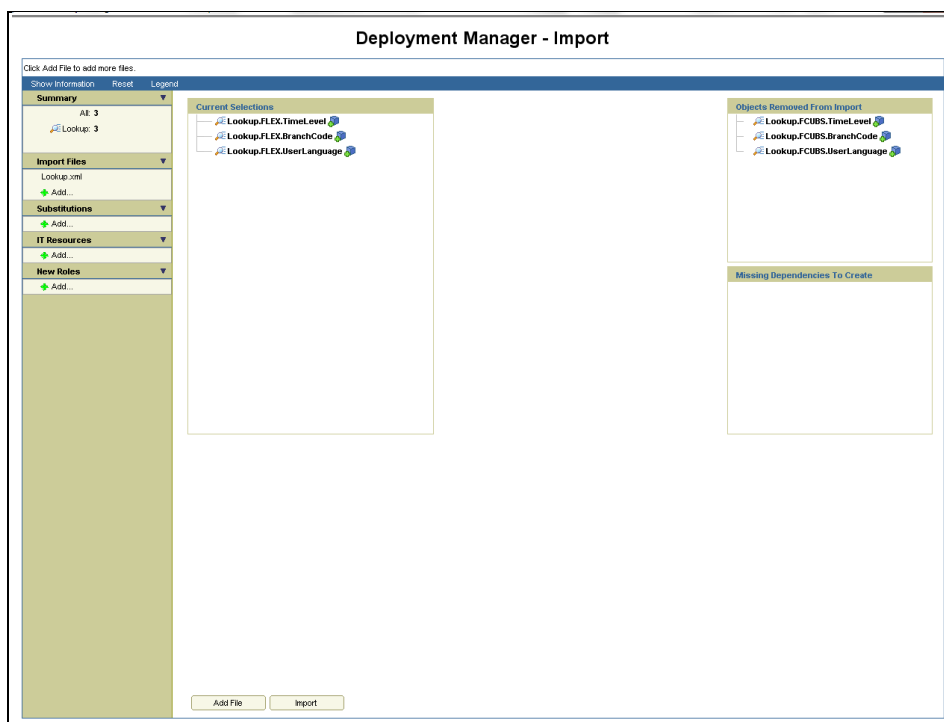
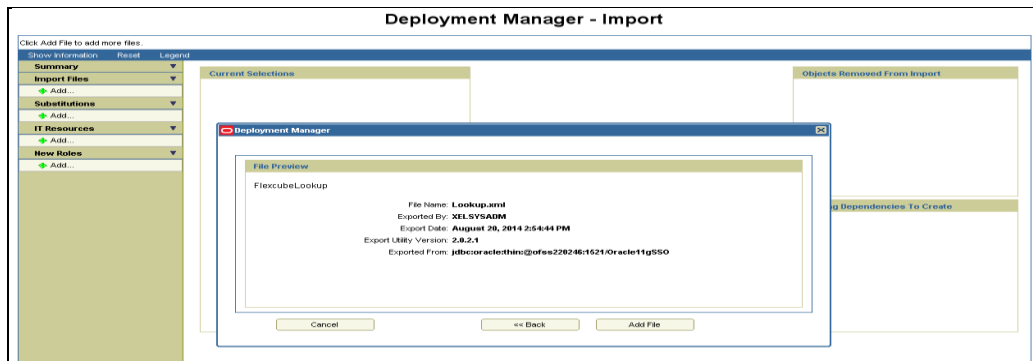

13. Click on Add File

14. Select Rule.xml file from the folder

<SPMLADAPTER\_INSTALL\_DIR>\OIM\OIM-Config\Sch-Tasks\Config-XML.

15. Click on Open.

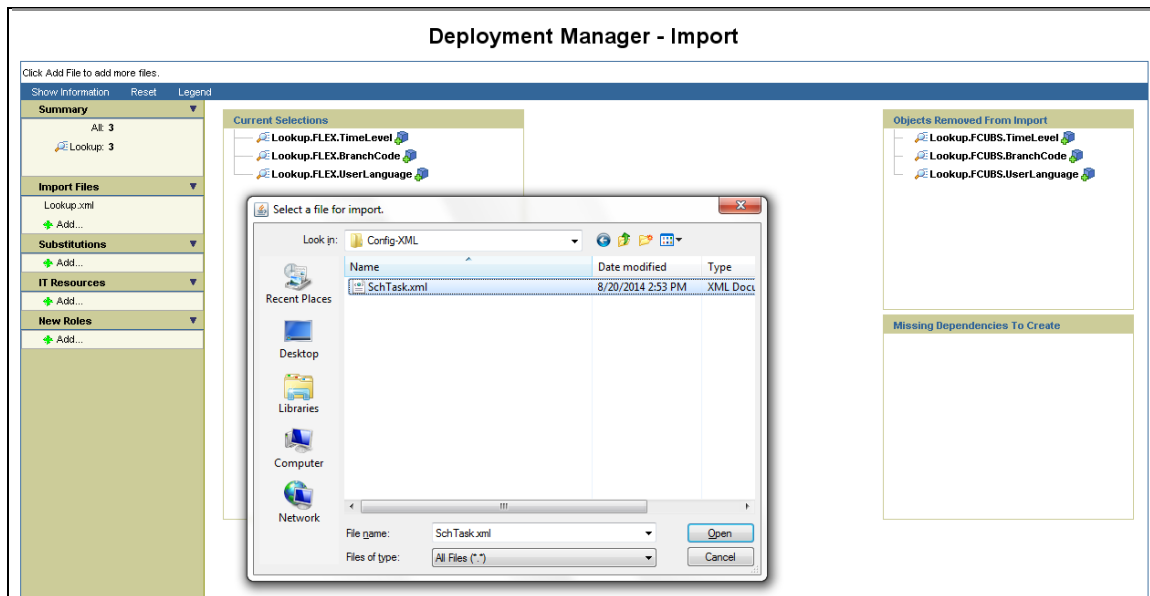

We will get File preview screen

16. Click on Add file.

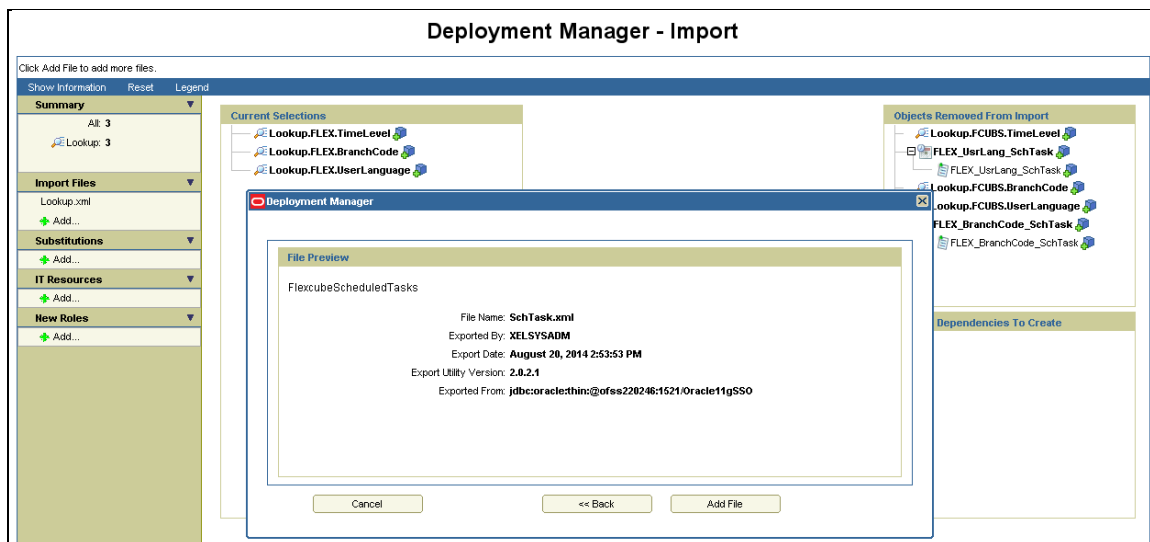



17. Click on Import.

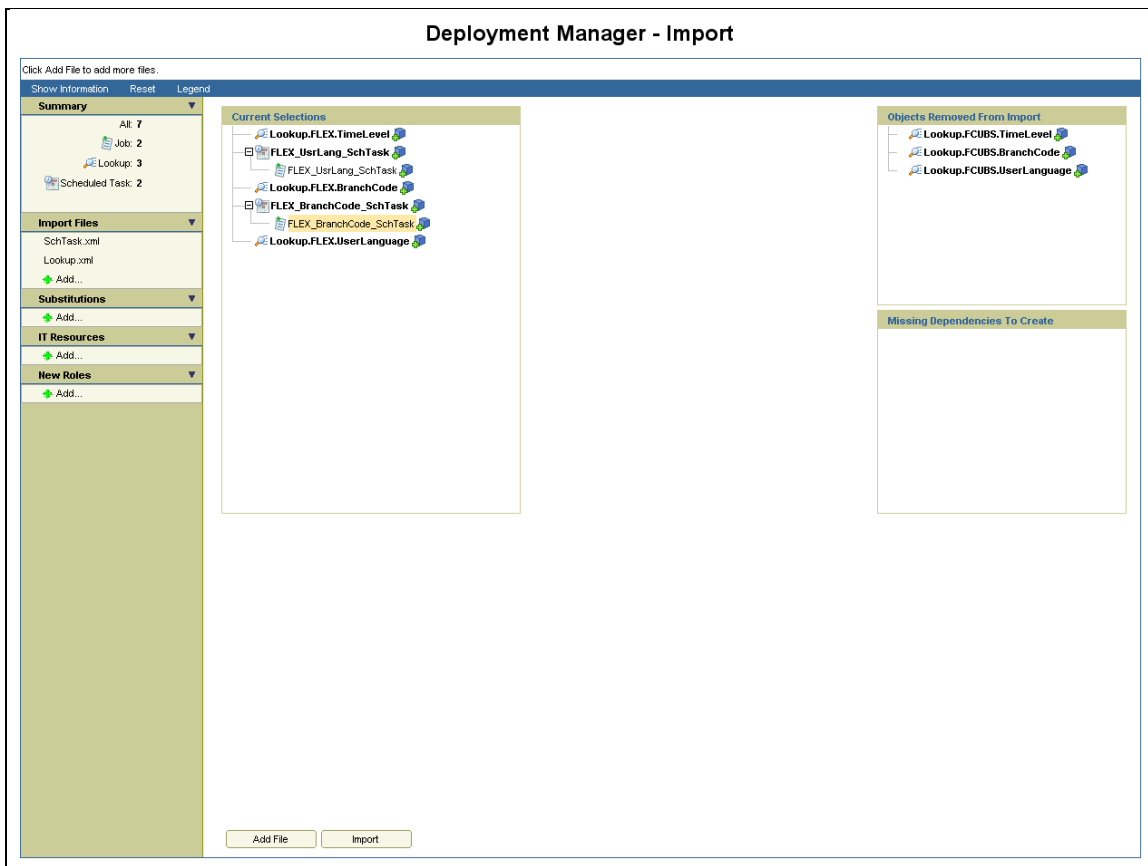

Above will prompt for Import Confirmation

18. Click on Import to start import.

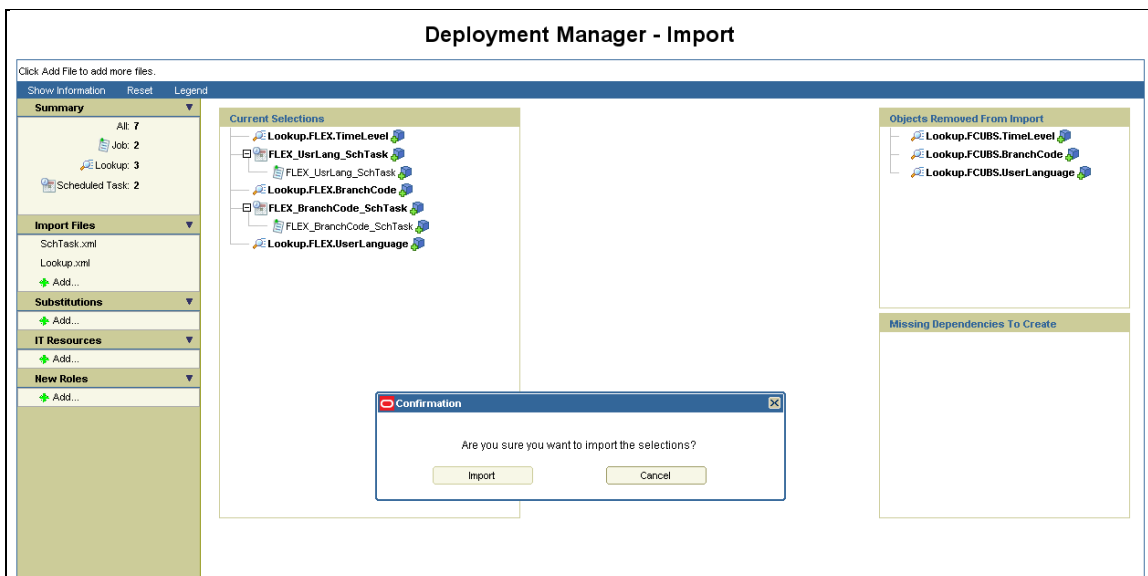

On successful import following screen will come.

19. Ensure that import is successful and click on ok.

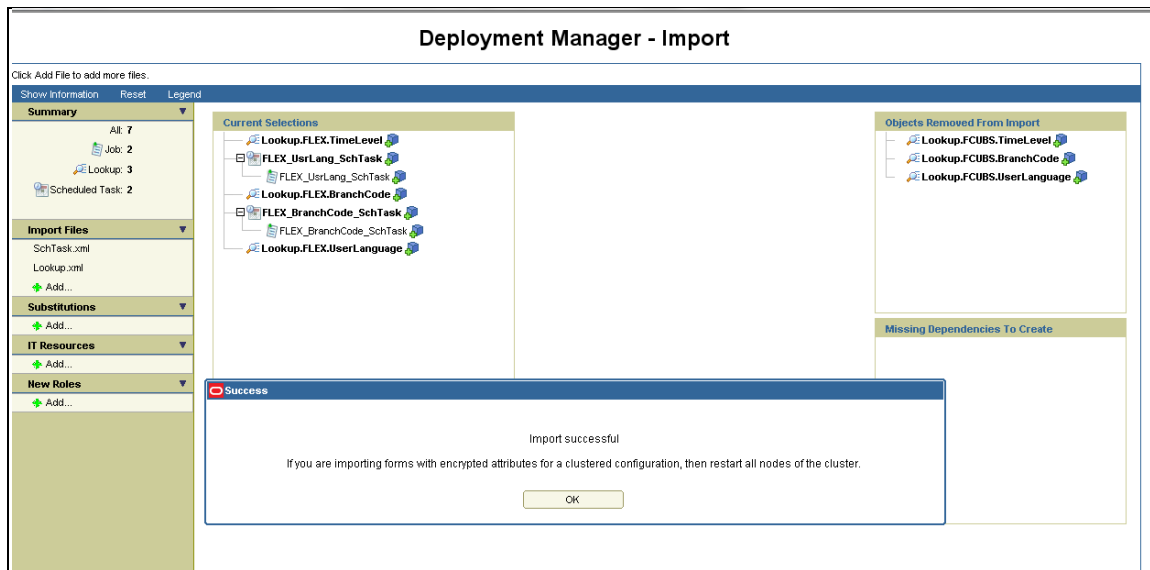

The following screen will get displayed.

20. Click on Add File.

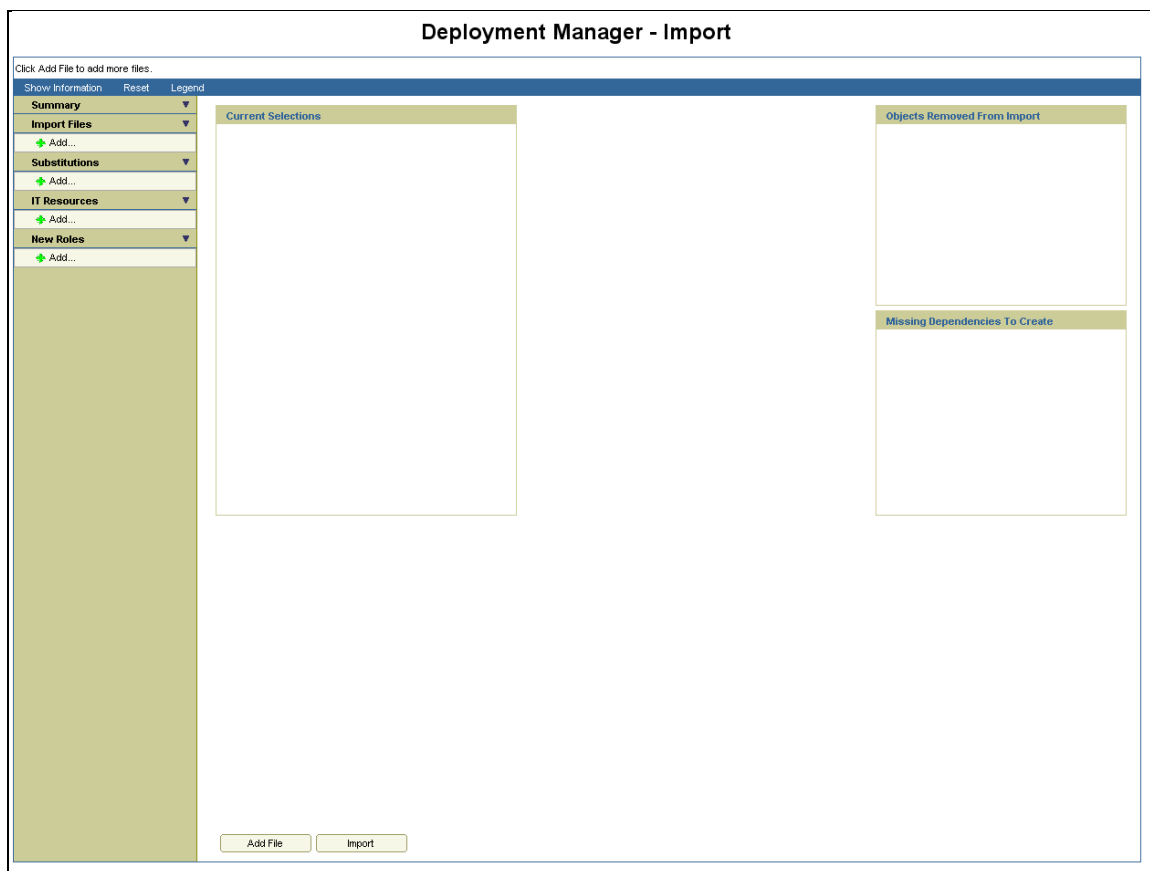

Open file window will get appeared.

21. Select GTC.xml file from the folder <SPMLADAPTER\_INSTALL\_DIR>\OIM\OIM-Config\GTC\.

22. Click on Open.

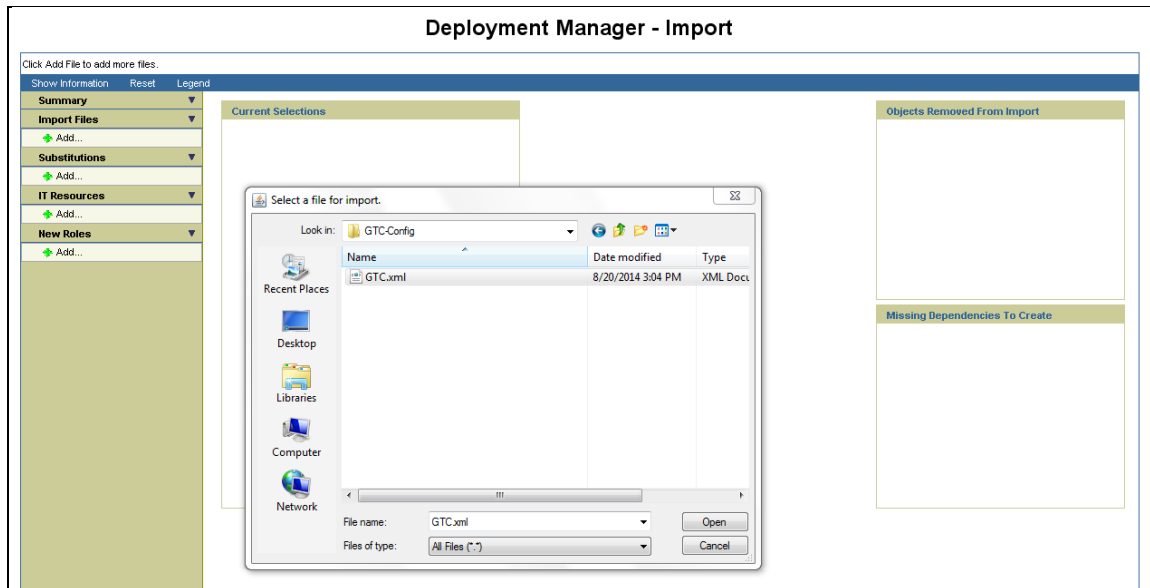

We will get File preview screen

23. Click on Add file.

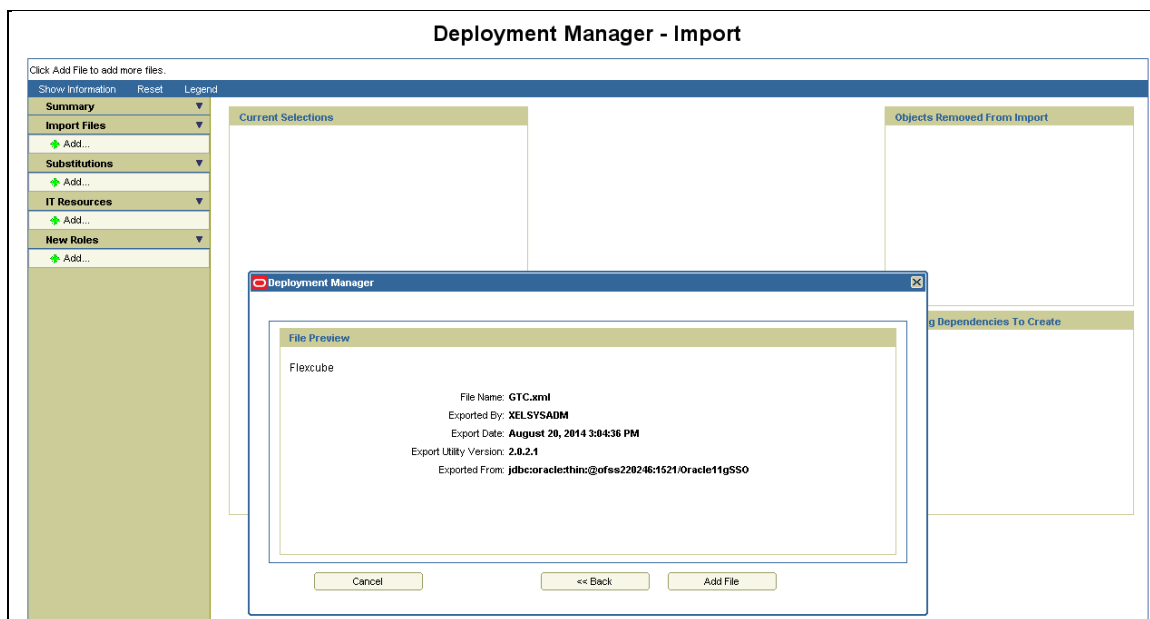

Next screen will be the substitution screen.

24. If the GTC is imported first time then click on Next.

25. If GTC have been already imported once successfully, change the Version name for example UD\_FLEXCUBE Version = FLEXCUBE V2.

26. Click on Next.

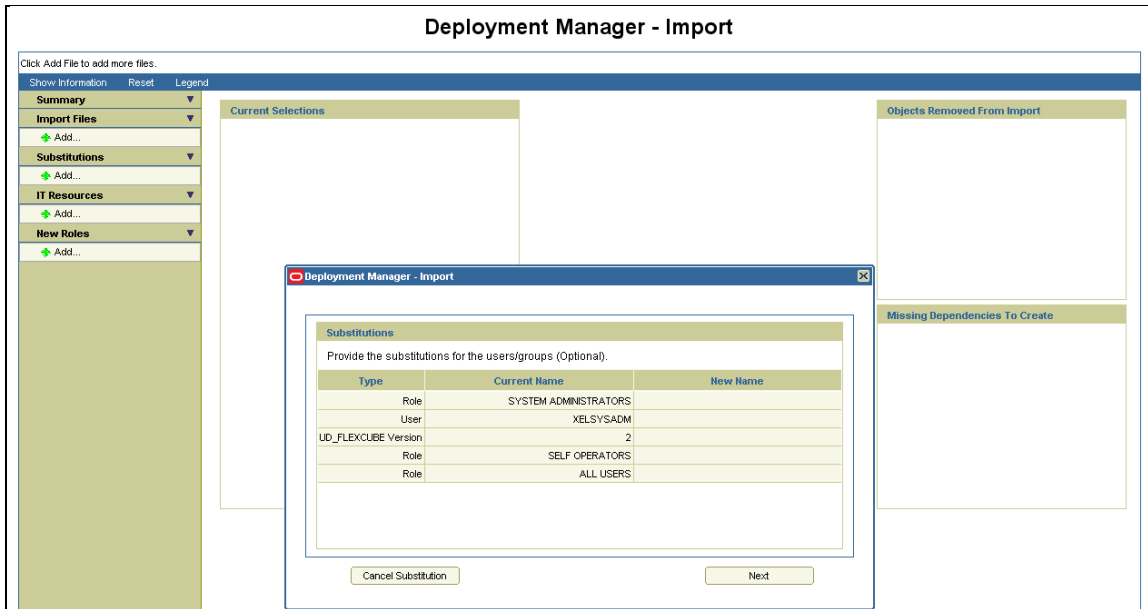

Above will prompt for substitution Confirmation

27. If any value has been changed on previous screen it will list those substitution otherwise below screen will get displayed. Click on Next.

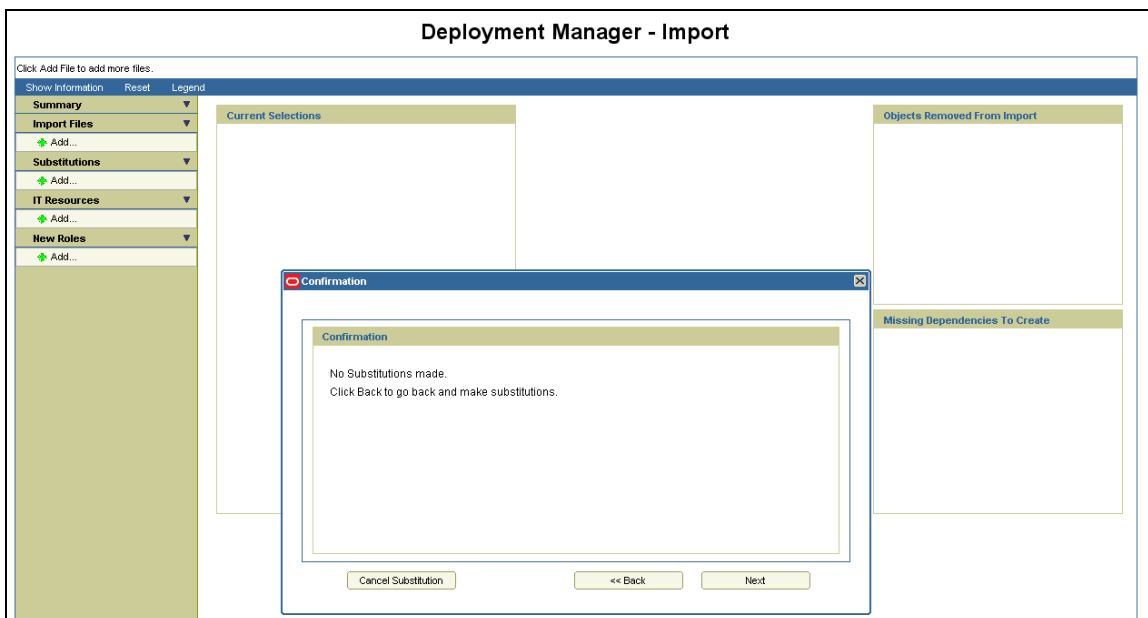



Next, Provide IT resource instance data screen will get displayed.

28. Ensure that the green arrow should point to FLEXCUBE\_GTC.

29. Provide followings to the right hand table:

Parameter Name	Parameter Value
SPML_targetID	FLEXCUBE
SharedDrive_filePrefix	SMOIMHOFF
SharedDrive_stageDirParent	Full path of the staging folder created in step 4 of OIM setup Eg: /home/Oracle/Oracle/Middleware/FCUBS-OIM-Config/Staging
Webservices_webserviceURL	Provisioning web service <b>FCUBSProvisioningAdService</b> URL deployed in step .Typically it should be like <a href="https://&lt;hostName&gt;:&lt;port&gt;/FCUBSProvisioningAdService/FCUBSProvisioningAdServiceSEI">https://&lt;hostName&gt;:&lt;port&gt;/FCUBSProvisioningAdService/FCUBSProvisioningAdServiceSEI</a>  Eg: <a href="https://ofss220223:14001/FCUBSProvisioningAdService/FCUBSProvisioningAdServiceSEI">https://ofss220223:14001/FCUBSProvisioningAdService/FCUBSProvisioningAdServiceSEI</a>
SharedDrive_archiveDir	Full path of the archiving folder created in step 4 of OIM setup Eg: /home/Oracle/Oracle/Middleware/FCUBS-OIM-Config/Archive
SharedDrive_delimeter	, [Comma ]
SharedDrive_uniqueAttrParent	USERID

30. Click on Next.

# Deployment Manager - Import

Click: Add File to add more files.

Show Information    Reset    Legend

- Summary
- Import Files
  - Add...
- Substitutions
- IT Resources
  - Add...
- New Roles
  - Add...

Current Selections

Objects Removed From Import

Missing Dependencies To Create

Deployment Manager

Provide IT Resource Instance Data.

FLEXCUBE\_GTC

FLEXCUBE\_GTC

Parameter Name	Parameter Value
SPML_username	
SharedDrive_uniqueAttrParent	USERID
WebServices_webServiceURL	https://otss220223-24001
SharedDrive_stageDirParent	/scratch/work_area/DEV/
SPML_targetID	FLEXCUBE
SharedDrive_archiveDir	/scratch/work_area/DEV/
SharedDrive_delimiter	,
SharedDrive_whetherTabDelimited	
SharedDrive_filePrefix	SMOIMHOFF
Timestamp	

Cancel IT Resource Modification    << Back    Skip    Next

The following screen will get displayed.

31. Click on Skip.

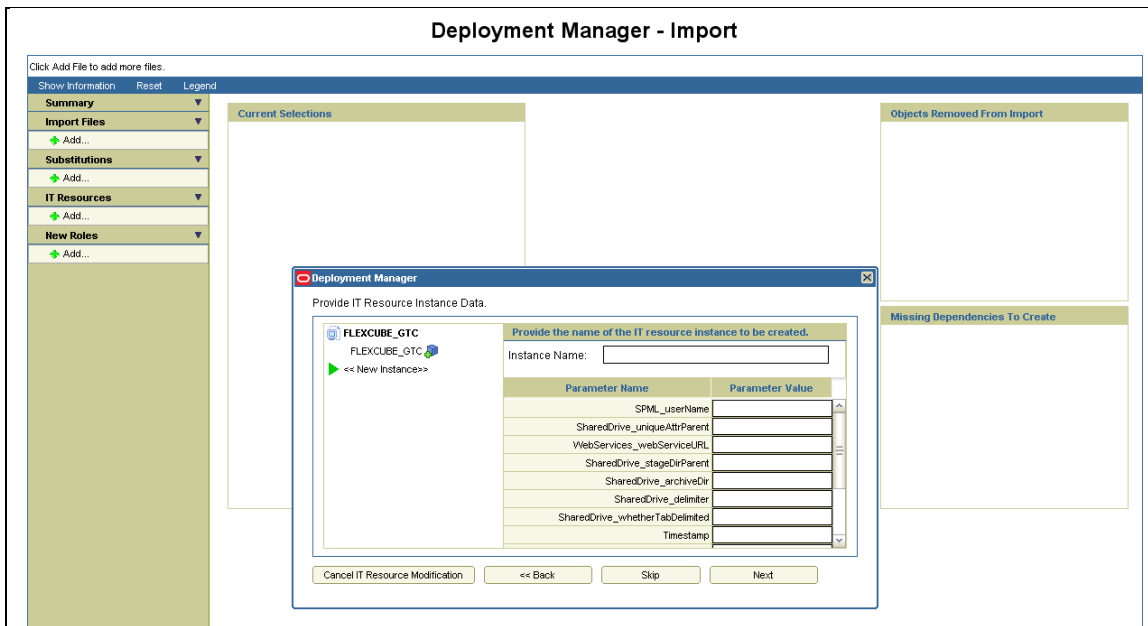

A confirmation window for parameter values will get displayed.

32. Confirm the values and click on View Selections.

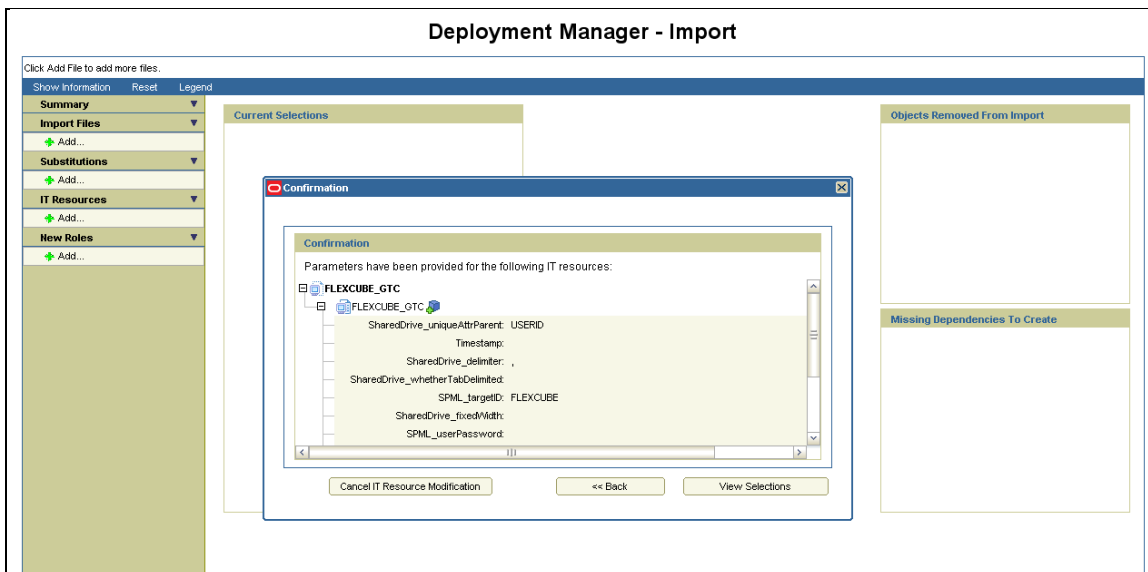

We will get Selection screen that will show all components of GTC.

33. Make sure that there should be no items in Missing Dependencies to create box on right below of the screen. If so, probably some previous imports has been missed out or not imported successfully. Repeat the earlier imports again.

34. Otherwise click on Import.



## Deployment Manager - Import

Click Add File to add more files.

Show Information    Reset    Legend

### Summary

All: 18

- IT Resource Definition: 1
- Resource: 1
- Task Adapter: 2
- Process Form: 1
- Entity Publication: 2
- Application Instance: 1
- Generic Connector: 1
- Organization: 3
- IT Resource: 1
- Password Policy: 1
- Job: 1
- Data Object Definition: 1
- Process: 1
- Scheduled Task: 1

### Import Files

GTC.xml  
Add...

### Substitutions

Add...

### IT Resources

FLEXCUBE\_GTC (FLEXCUBE\_GT  
<    ||    >

### New Roles

### Current Selections

```
graph TD; Root[FLEXCUBE_GTC] --> Child1[FLEXCUBE_GTC]; Root --> Child2[FLEXCUBE]; Root --> Child3[FLEXCUBE_GTC]; Child2 --> Child2_1[adpFLEXCUBE_GTC_AUTOC]; Child2 --> Child2_2[UD_FLEXCUBE]; Child2 --> Child2_3[adpFLEXCUBE_GTC]; Child3 --> Child3_1[ApplicationInstance2]; Child3_1 --> Child3_1_1[Top]; Child3_1 --> Child3_1_2[Default Policy]; Child3_1 --> Child3_1_3[Xellerate Users]; Child3_1 --> Child3_1_4[Requests]; Child3 --> Child3_2[ApplicationInstance3]; Child3_2 --> Child3_2_1[Requests]; Child3 --> Child3_3[FLEXCUBE_GTC]; Child3_3 --> Child3_3_1[ApplicationInstance2]; Child3_3_1 --> Child3_3_1_1[Top]; Child3_3_1_1 --> Child3_3_1_1_1[Default Policy];
```

### Objects Removed From Import

### Missing Dependencies To Create

Add File    Import

Above will prompt for Import Confirmation

35. Click on Import to start import.

### Deployment Manager - Import

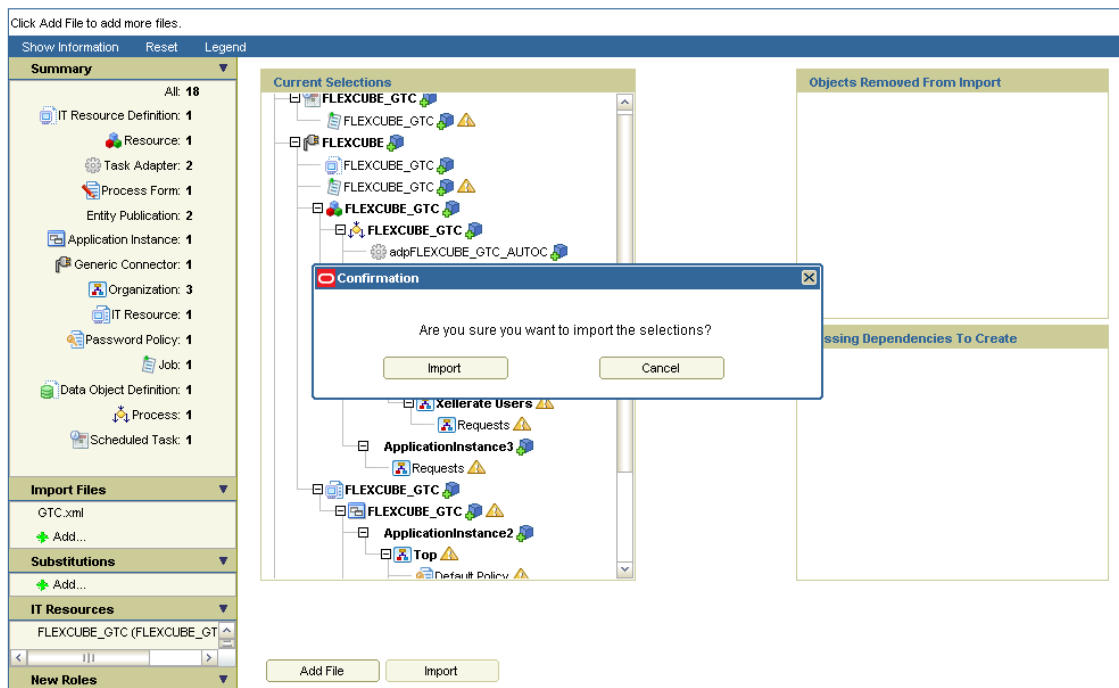

**Note:** Import of GTC.xml may take more time as compare to other imports.

On successful import following screen will come.

36. Ensure that import is successful and click on ok.

# Deployment Manager - Import

Click Add File to add more files.

Show Information    Reset    Legend

**Summary**

All: 18

- IT Resource Definition: 1
- Resource: 1
- Task Adapter: 2
- Process Form: 1
- Entity Publication: 2
- Application Instance: 4

**Import Files**

- GTC.xml
- Add...

**Substitutions**

- Add...

**IT Resources**

- FLEXCUBE\_GTC (FLEXCUBE\_GT

**New Roles**

**Current Selections**

- FLEXCUBE\_GTC
- FLEXCUBE\_GTC
- FLEXCUBE\_GTC
- FLEXCUBE\_GTC
- FLEXCUBE\_GTC
- FLEXCUBE\_GTC

**Objects Removed From Import**

**Success**

Import successful

If you are importing forms with encrypted attributes for a clustered configuration, then restart all nodes of the cluster.

OK

**Organization**

- Requests
- ApplicationInstance3
- Requests
- FLEXCUBE\_GTC
- FLEXCUBE\_GTC
- ApplicationInstance2
- Top
- Default Policy

Add File    Import

37. Click on Sandboxes.



38. Click on Create Sandbox.

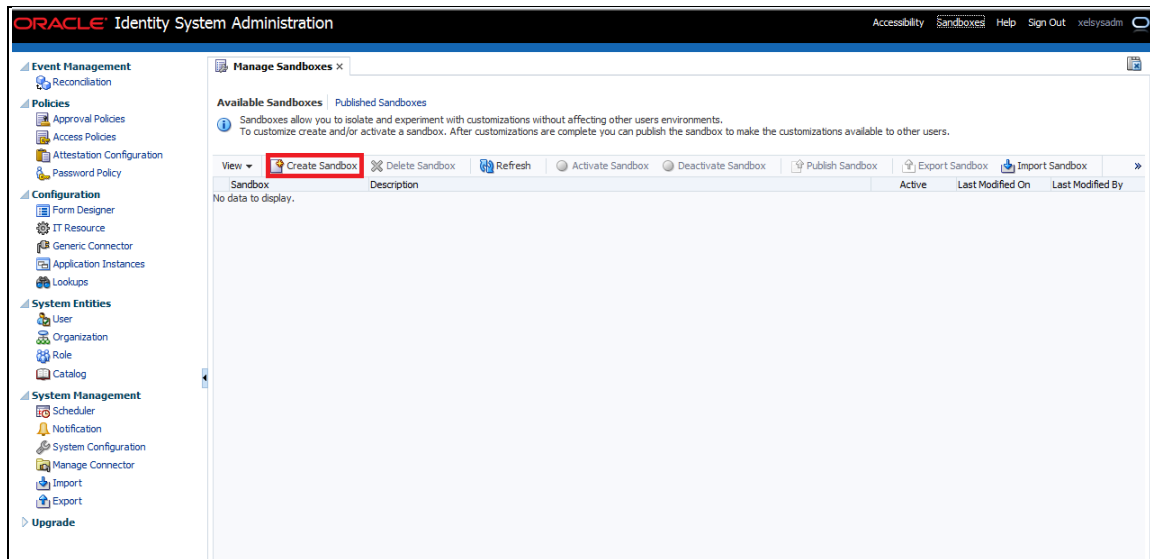

Enter the Below Details and Click on Save and Close.

39. Sandbox Name : FlexcubeSandbox

40. Sandbox Description : FlexcubeSandbox

ORACLE Identity System Administration Accessibility Sandboxes Help Sign Out xelsysadm

**Manage Sandboxes** x

**Available Sandboxes** | **Published Sandboxes**

Sandboxes allow you to isolate and experiment with customizations without affecting other users environments. To customize create and/or activate a sandbox. After customizations are complete you can publish the sandbox to make the customizations available to other users.

View     Activate Sandbox  Deactivate Sandbox    »

Sandbox	Description	Active	Last Modified On	Last Modified By
No data to display.				

**Create Sandbox** x

\* Sandbox Name

Sandbox Description

Activate Sandbox

41. Click on Ok.

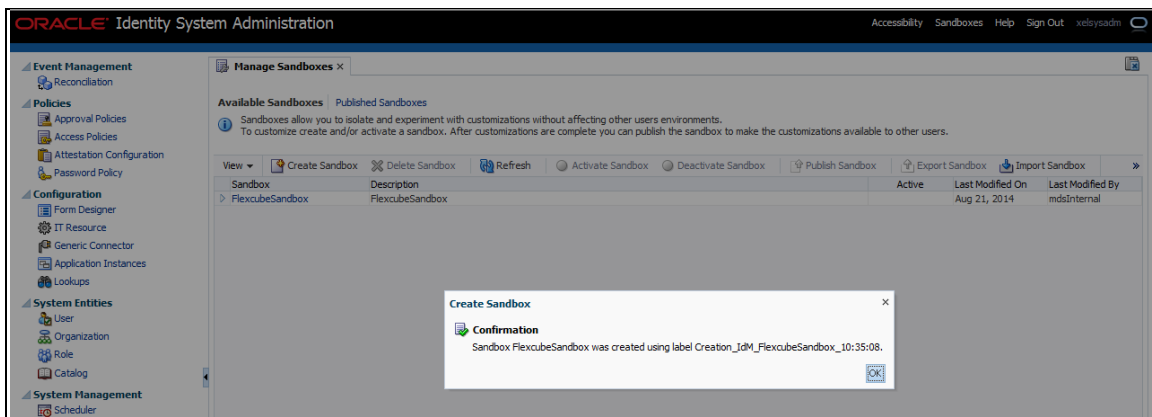

42. Click on Form Designer.

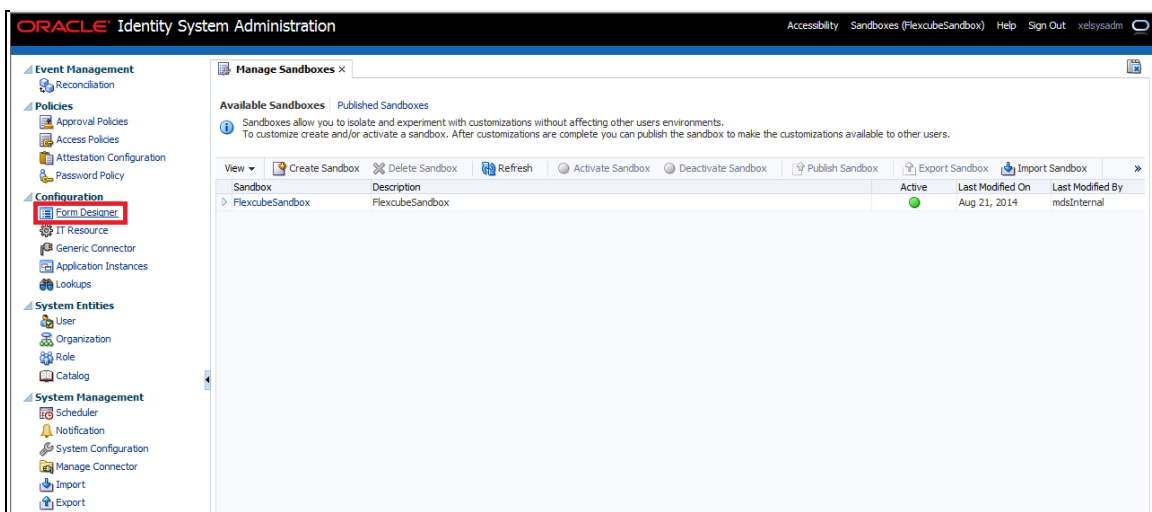

43. Click on Create

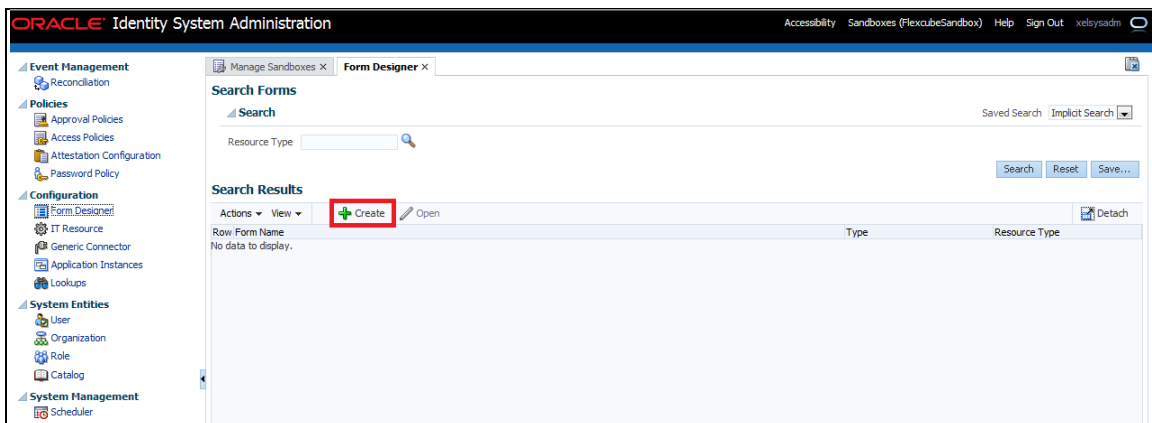

44. Enter the below details and Click on Create

- Resource Type : FLEXCUBE\_GTC
- Form Name : FlexcubeForm

Note\*: Form Name should be same as above

Oracle Identity System Administration - Manage Sandboxes X | Form Designer X | Create Form X

New form for FLEXCUBE\_GTC

Resource Type: FLEXCUBE\_GTC  
Form Name: FlexcubeForm

Available form fields

#	Display Name	Name	Description	Bulk Update
1	containerID	UD_FLEXCUBE_CONTAINERID	containerID	<input type="checkbox"/>
2	objectclass	UD_FLEXCUBE_OBJECTCLASS	objectclass	<input type="checkbox"/>
3	ID	UD_FLEXCUBE_ID	ID	<input type="checkbox"/>
4	USERID	UD_FLEXCUBE_USERID	USERID	<input type="checkbox"/>
5	USERNAME	UD_FLEXCUBE_USERNAME	USERNAME	<input type="checkbox"/>
6	USERPASSWORD	UD_FLEXCUBE_USERPASSWORD	USERPASSWORD	<input type="checkbox"/>
7	HOMEBRANCH	UD_FLEXCUBE_HOMEBRANCH	HOMEBRANCH	<input type="checkbox"/>
8	USERLANGUAGE	UD_FLEXCUBE_USERLANGUAGE	USERLANGUAGE	<input type="checkbox"/>
9	TIMELEVEL	UD_FLEXCUBE_TIMELEVEL	TIMELEVEL	<input type="checkbox"/>
10	STARTDATE	UD_FLEXCUBE_STARTDATE	STARTDATE	<input type="checkbox"/>
11	EMAIL	UD_FLEXCUBE_EMAIL	EMAIL	<input type="checkbox"/>
12	LDAPUSR	UD_FLEXCUBE_LDAPUSR	LDAPUSR	<input type="checkbox"/>
13	IT Resource2	UD_FLEXCUBE_IT_RES	IT Resource2	<input type="checkbox"/>

Successful form creation will be like below:

Oracle Identity System Administration - Manage Sandboxes X | Form Designer X

Form created successfully

Search Forms

Resource Type: [Search]

Search Results

Row	Form Name	Type	Resource Type
No data to display.			

45. Click on Application Instances.

ORACLE Identity System Administration Accessibility Sandboxes (FlexcubeSandbox) Help Sign Out velsysadm

✔ Form created successfully

Manage Sandboxes X Form Designer X

**Event Management**  
Reconciliation

**Policies**  
Approval Policies  
Access Policies  
Attestation Configuration  
Password Policy

**Configuration**  
Form Designer  
IT Resource  
Generic Connector  
**Application Instances**  
Lookups

**System Entities**  
User  
Organization  
Role  
Catalog

**System Management**  
Scheduler  
Notification  
System Configuration  
Manage Connector  
Import  
Export

Upgrade

**Search Forms**

Search Saved Search Implicit Search

Resource Type

Search Reset Save...

**Search Results**

Actions View + Create ✎ Open Detach

Row	Form Name	Type	Resource Type
No data to display.			



46. Click on Search.

The screenshot shows the Oracle Identity System Administration interface. The left sidebar contains a navigation menu with categories like Event Management, Policies, Configuration, System Entities, and System Management. The main content area is titled "Search Application Instances" and includes a search filter section with dropdown menus for "Resource Object", "Display Name", and "IT Resource Instance". Below the filters are buttons for "Search", "Reset", "Save...", and "Add Fields". The "Search" button is highlighted with a red box. Below the buttons is a "Search Results" section with a table header and a "No data to display" message.

47. Click on FLEXCUBE\_GTC.

The screenshot shows the Oracle Identity System Administration interface. The left sidebar is the same as in the previous screenshot. The main content area is titled "Search Application Instances" and includes the same search filter section. Below the filters are buttons for "Search", "Reset", "Save...", and "Add Fields". The "Search" button is highlighted with a red box. Below the buttons is a "Search Results" section with a table header and a row of results. The row for "FLEXCUBE\_GTC" is highlighted with a red box.

Row	Display Name	Description	Resource Object	IT Resource Instance
1	FLEXCUBE_GTC	FLEXCUBE_GTC	FLEXCUBE_GTC	FLEXCUBE_GTC

48. Choose the Form as FlexcubeForm and Click on Apply.

ORACLE Identity System Administration Accessibility Sandboxes (FlexcubeSandbox) Help Sign Out xebysadm

Manage Sandboxes x Form Designer x Application Instances x FLEXCUBE\_GTC x

### Application Instance: FLEXCUBE\_GTC

Attributes Organizations Entitlements \*Required Field **Apply** Revert

Name FLEXCUBE\_GTC

\* Display Name FLEXCUBE\_GTC

Description FLEXCUBE\_GTC

Resource Object FLEXCUBE\_GTC

IT Resource Instance FLEXCUBE\_GTC

Form  Edit Refresh

Parent App Instance **FlexcubeForm**

FlexcubeForm

- Event Management
  - Reconciliation
- Policies
  - Approval Policies
  - Access Policies
  - Attestation Configuration
  - Password Policy
- Configuration
  - Form Designer
  - IT Resource
  - Generic Connector
  - Application Instances
  - Lookups
- System Entities
  - User
  - Organization
  - Role
  - Catalog
- System Management
  - Scheduler
  - Notification
  - System Configuration
  - Manage Connector

On Successful modification will be shown like below:

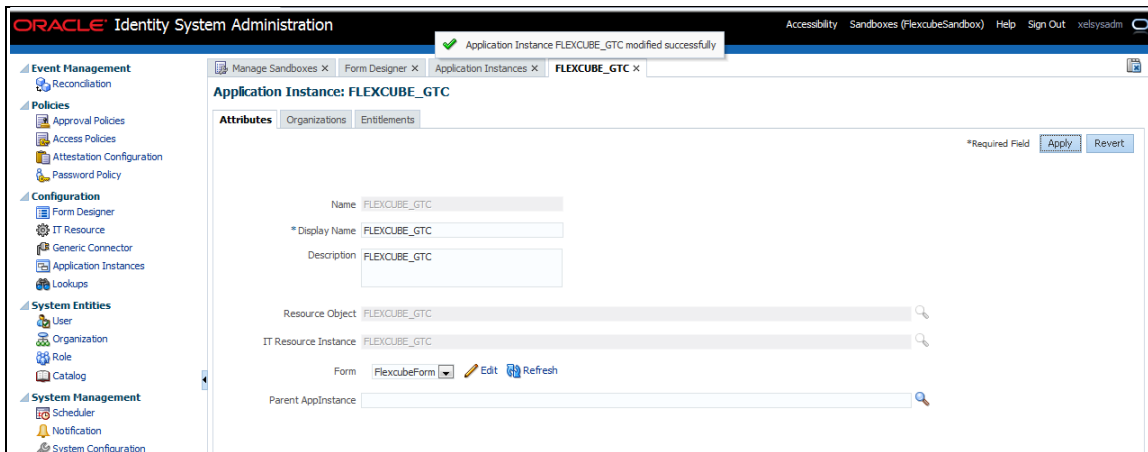

Application Instance belongs to the following Organizations

Note: In case provisioning has to be applied for different Organizations then Create the Organizations under System Entities and map those Organizations to the Application Instance.

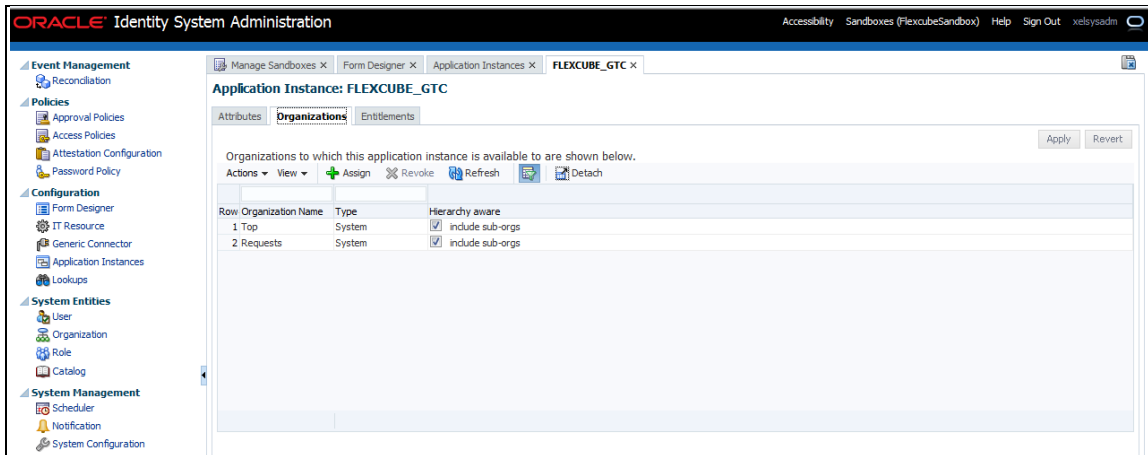

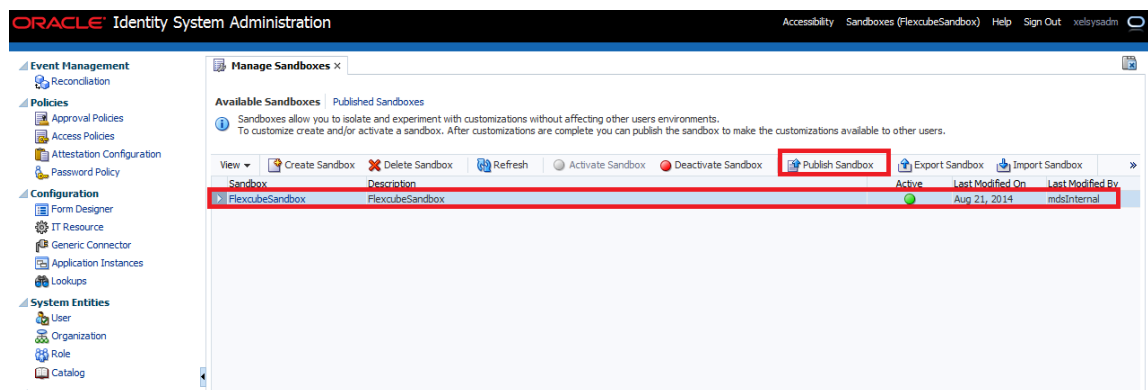

49. Select and click on Publish Sandbox.

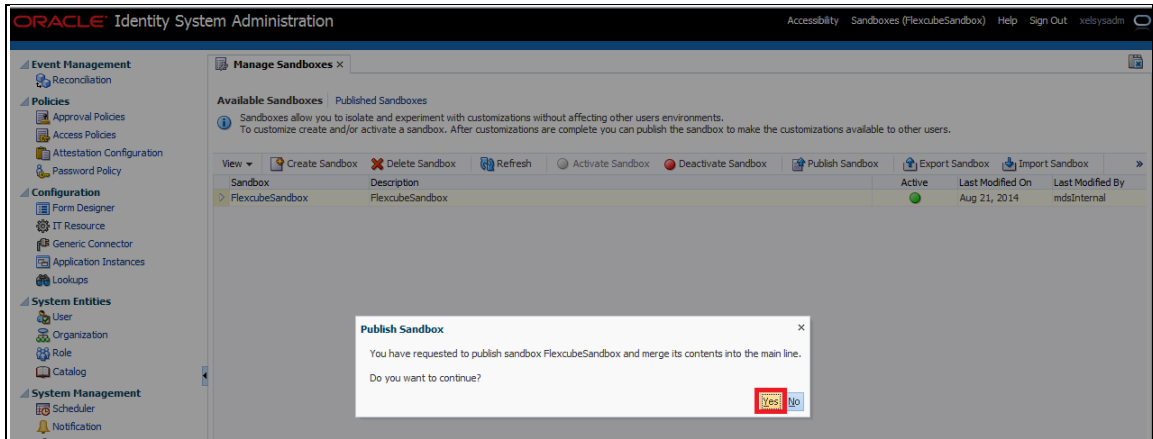

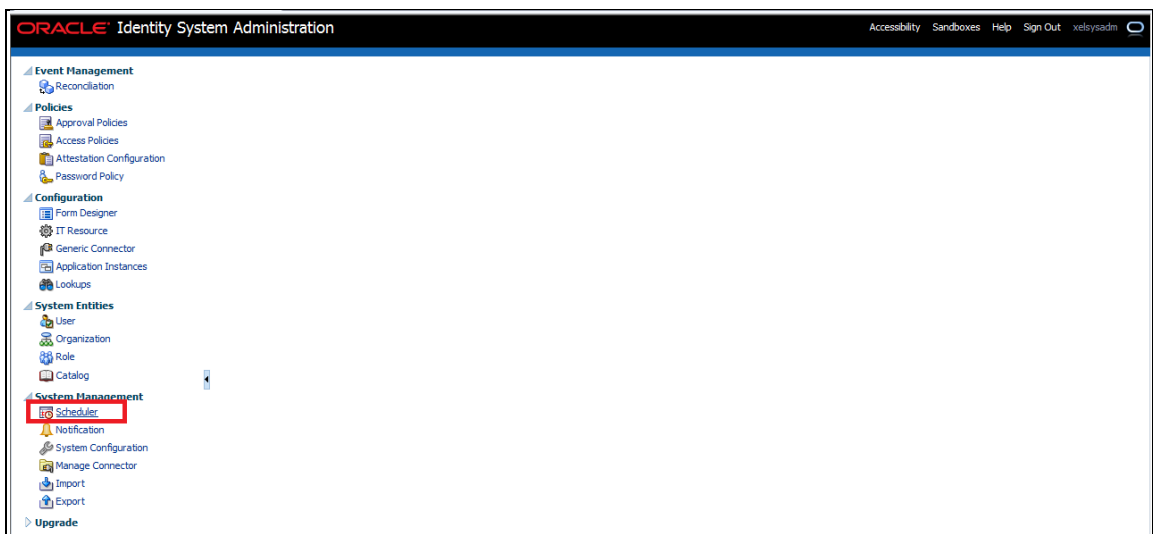

50. Click on Scheduler under System Management.



51. Click on  to Search for Scheduled Job List.

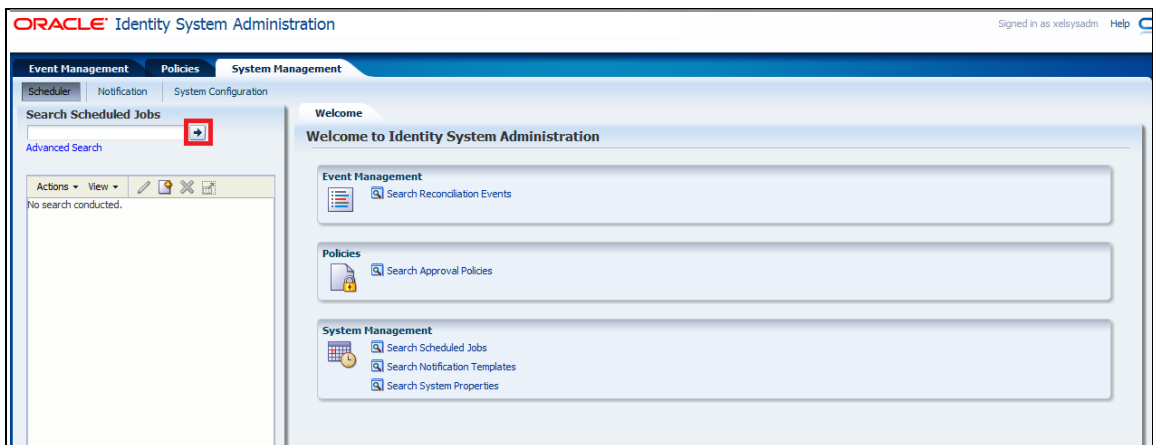

## 52. Click on Entitlement List

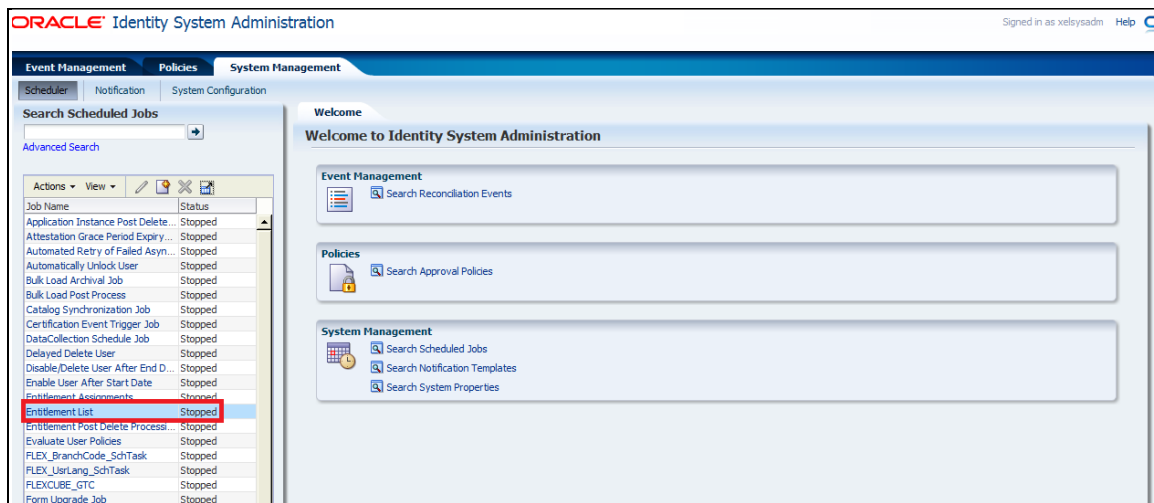

## 53. Click on Run.

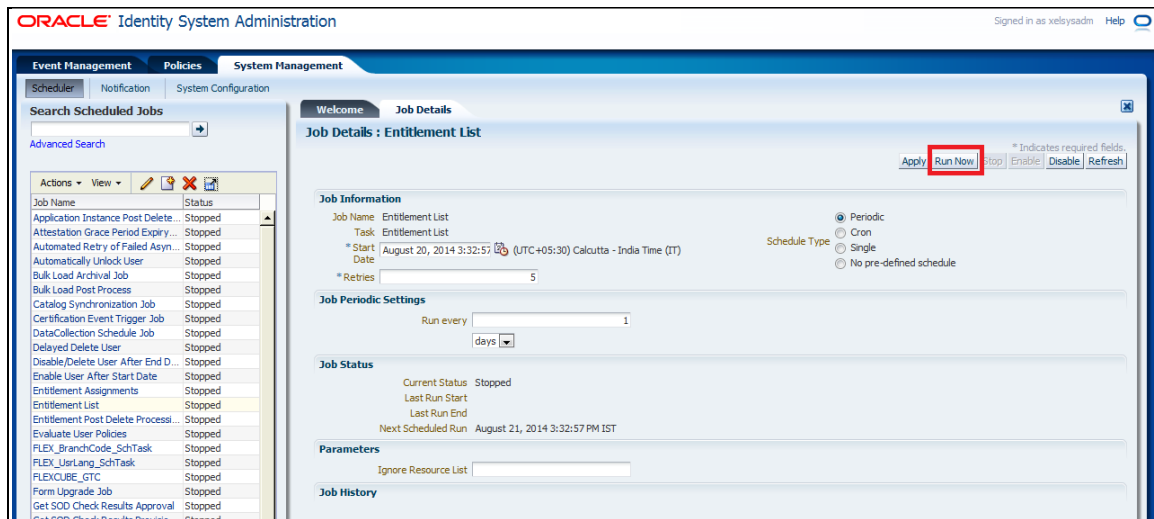

### 5.1.5.1.1 Schedule Task Setup

This step involves setting up Schedule task parameters.

1. Open the Oracle Identity Manager Administrative console. (Give the following URL in the browser: <http://<hostname>:<oimport>/sysadmin>)

2. Enter OIM administrator username/password and press Login.

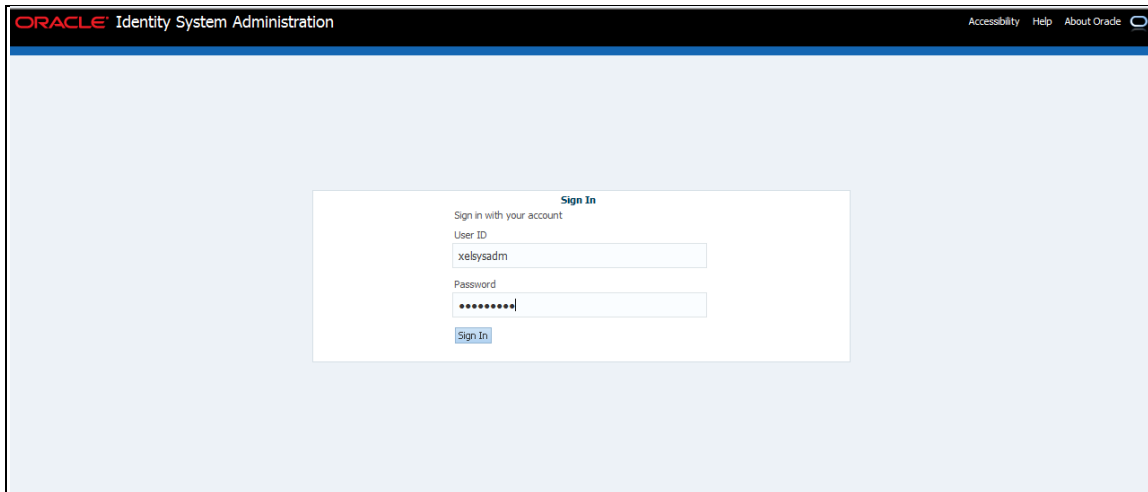

3. Click on Scheduler under System Management.

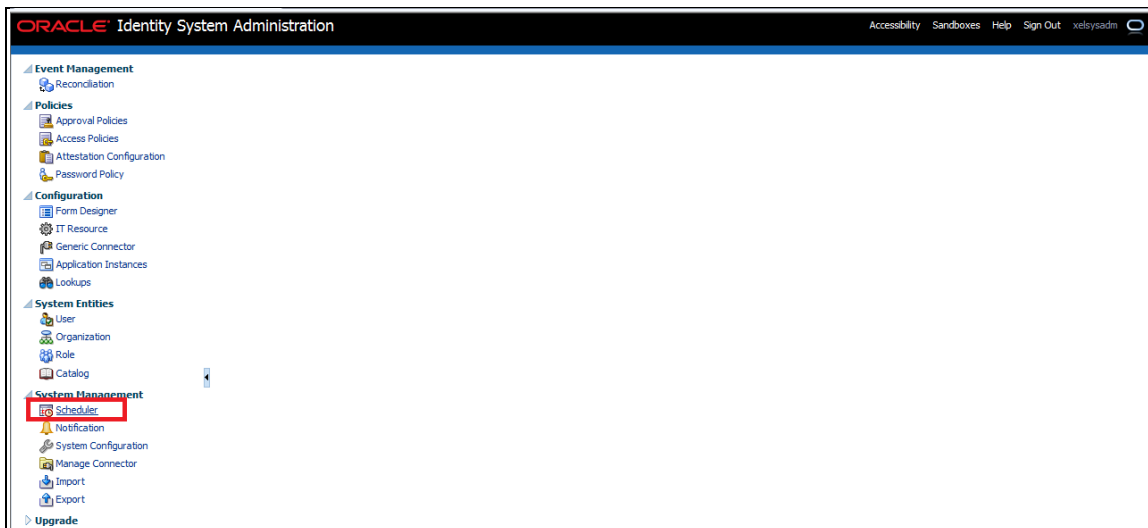

4. Click on  to Search for Scheduled Job List.

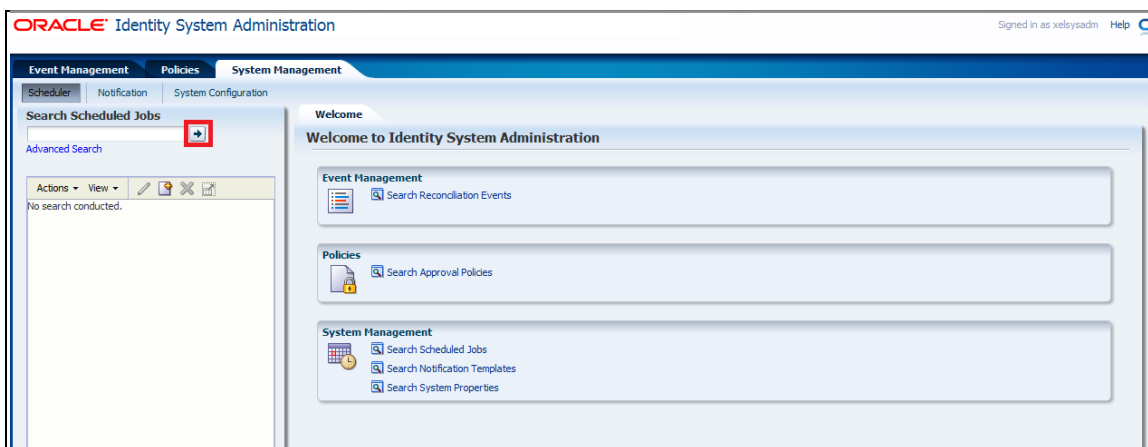

5. Click on FLEX\_BranchCode\_SchTask.

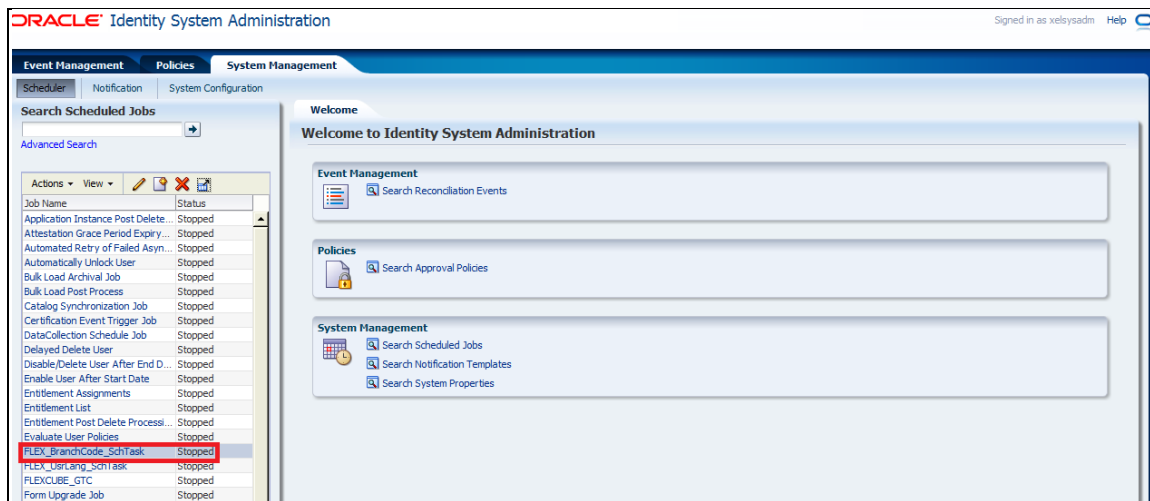

6. On the Edit Schedule Task screen.

- WebService Url : FCUBSLOVAdService deployed in section [5.1.4.2.1](#)

`https://<hostname>:<ssl_oimport>/FCUBSLOVAdService/FCUBSLOVAdServiceSEI`

- Query :

FCUBS :

`select branch_code||'~'||branch_code from sttm_branch order by branch_code`

FCIS :

`select moduleid||'~'||moduleid from moduleprofilebasetbl where once_auth='Y' order by moduleid`

- Click on Apply and Click on Run.





## 7. Modify FLEX\_UsrLang\_SchTask job

- WebService Url : FCUBSLOVAdService deployed in section 5.1.4.2.1

https://<hostname>:<ssl\_oimport>/FCUBSLOVAdService/FCUBSLOVAdServiceSEI

- Click on Apply and Click on Run.

The screenshot displays the Oracle Identity System Administration interface. The main content area is titled "Job Details: FLEX\_UsrLang\_SchTask". At the top right of this section, there are buttons for "Apply", "Run Now", "Stop", "Enable", "Disable", and "Refresh". The "Apply" and "Run Now" buttons are highlighted with red boxes. Below the buttons, the "Job Information" section shows the job name as "FLEX\_UsrLang\_SchTask" and the task as "FLEX\_UsrLang\_SchTask". The "Job Status" section indicates the current status is "Stopped" and provides the last run start and end times. The "Parameters" section contains several fields: "Lookup Name" (Lookup.FLEX.UserLanguage), "WebService Name" (FCUBSLOVAdService), "WebService Namespace" (http://ovservice.ws.oim.integration), "WebService Operation" (lookup), and "WebService Url" (https://10.184.133.175:24001/FCU...), which is also highlighted with a red box. The "Query" field contains the SQL query: "select LANG\_CODE||'~'||LANG\_CODE".

## 5.1.6 System Configurations

### 5.1.6.1 Integration Specific Configurations

#### 5.1.6.1.1 FCUBS Configurations

On FCUBS side following configurations need to be done:

- Maintenance of Maker ID
- Maintenance of External Source

Both configurations can be done using FCJ provided screens.

##### 1. Maintenance of Maker ID

The FCJ screen can be open through Security Maintenance >> Users >> Detailed menu or using the function SMDUSRDF.

##### 2. Maintenance of External Source

For OIM request and response handling, an external source should be maintained in FCUBS database.

The FCJ screen can be open through Gateway >> External System >> Detailed menu or using the function 'GWDEXSYS'.

This external source should be able to do all operations like Create	Modify	Close	Open	View. This can be maintained through function GWDEXFUN or through Gateway >> External System Functions >> Detailed. Required actions and their corresponding details are given as below.
--	--------	-------	------	--

Action	Function	Service Name	Operation Code
NEW	SMGUSRDF	FCUBSSMService	CreateUserMaint
UNLOCK	SMGUSRDF	FCUBSSMService	ModifyUserMaint
DELETE	SMGUSRDF	FCUBSSMService	DeleteUserMaint
CLOSE	SMGUSRDF	FCUBSSMService	CloseUserMaint
REOPEN	SMGUSRDF	FCUBSSMService	ReopenUserMaint
VIEW	SMQUSRDF	FCUBSSMService	QueryUserMaint

Ensure that required maintenance has been done for function CODSORCE (Gateway >> Source>> Detailed) and for function CODUPLDM (Gateway >> Source Preferences >> Detailed menu).

For maintenance of amendable fields in GWTM\_AMEND\_NODES and GWTM\_AMEND\_FIELDS entries can be made using the function STDAMDMT or through Gateway >> Amendment Maintenance >> Detailed. Following table gives the amendable node and fields details that should be maintained.

Field Name	Value
Amend Nodes section	
Node Name	SMTB_USER
New Allowed	Checked
Delete Allowed	Checked
All Records	Checked
Amend Fields section	
Field Name	HOME_BRANCH
Field Name	START_DATE
Field Name	TIME_LEVEL
Field Name	USER_LANGUAGE
Field Name	USER_NAME
Field Name	USER_PASSWORD
Field Name	SALT

### **5.1.6.2 OIM Configurations**

#### **OID Connector Configuration**

For FLEXCUBE single sign on mode, the provisioning process consist of user creation in underlying LDAP directory and then provsioining into FLEXCUBE. OIM porvides out of box connectors for LDAP directorires. This connectors provides facility to connect with LDAP and to do the operation through OIM console.

In this integration, the underlying directory for Oracle access manager is Oracle Internet Directory. OIM porvides out of box connector for it that need to be imported as the connector document provided by OIM. After import, following steps should be followed :

1. Login to the Design Console.

Oracle Identity Manager Design Cons \_ x

Welcome To



Oracle Identity Manager  
Design Console



User ID

Password

Version 11.1.2.2.0.0.0

2. Navigate to the Administration>>Lookup Definition menu

3. Enter the below details:

- Code: Lookup.OID.Organization
- Click on **Search**  Icon
- Click on **Add**  button
- Enter the below details:
- Code Key : cn=Users,dc=in,dc=oracle,dc=com
- Decode : cn=Users,dc=in,dc=oracle,dc=com

4. Click on Save .

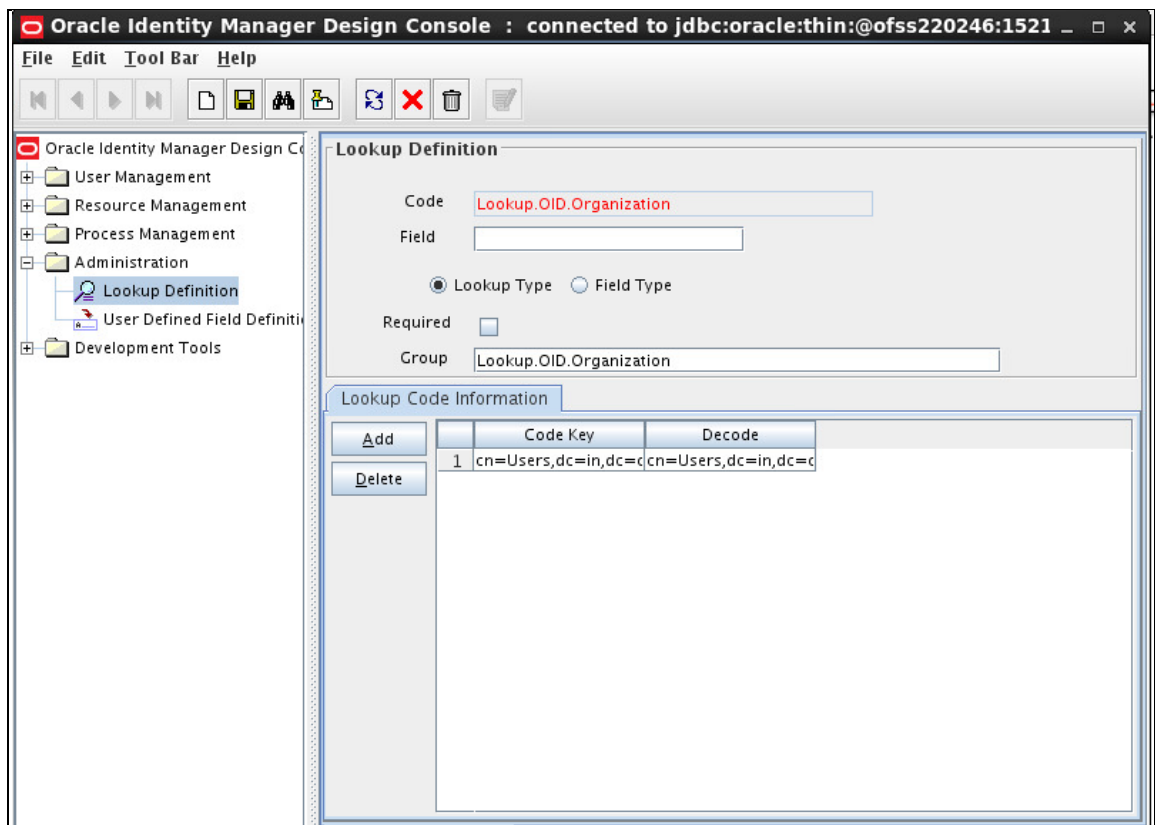

5. Navigate to the Administration>>Lookup Definition menu

6. Enter the below details:

- Code: Lookup.OID.UM.ProvAttrMap
- Click on Search  Icon
- Modify the Decode value for Code Key Name:
- From : \_\_NAME\_\_="uid=\${User\_ID},\${Container\_DN}"
- To : \_\_NAME\_\_="cn=\${User\_ID},\${Container\_DN}"

7. Click on Save .

8. Navigate to the Resource Management>>Resource Objects menu. This will open a blank screen.
9. Enter FLEXCUBE\_GTC in Name box.
10. Click on Search icon.
11. This will show the definition for resource FLEXCUBE\_GTC. Click on Assign button in Depends On tab.

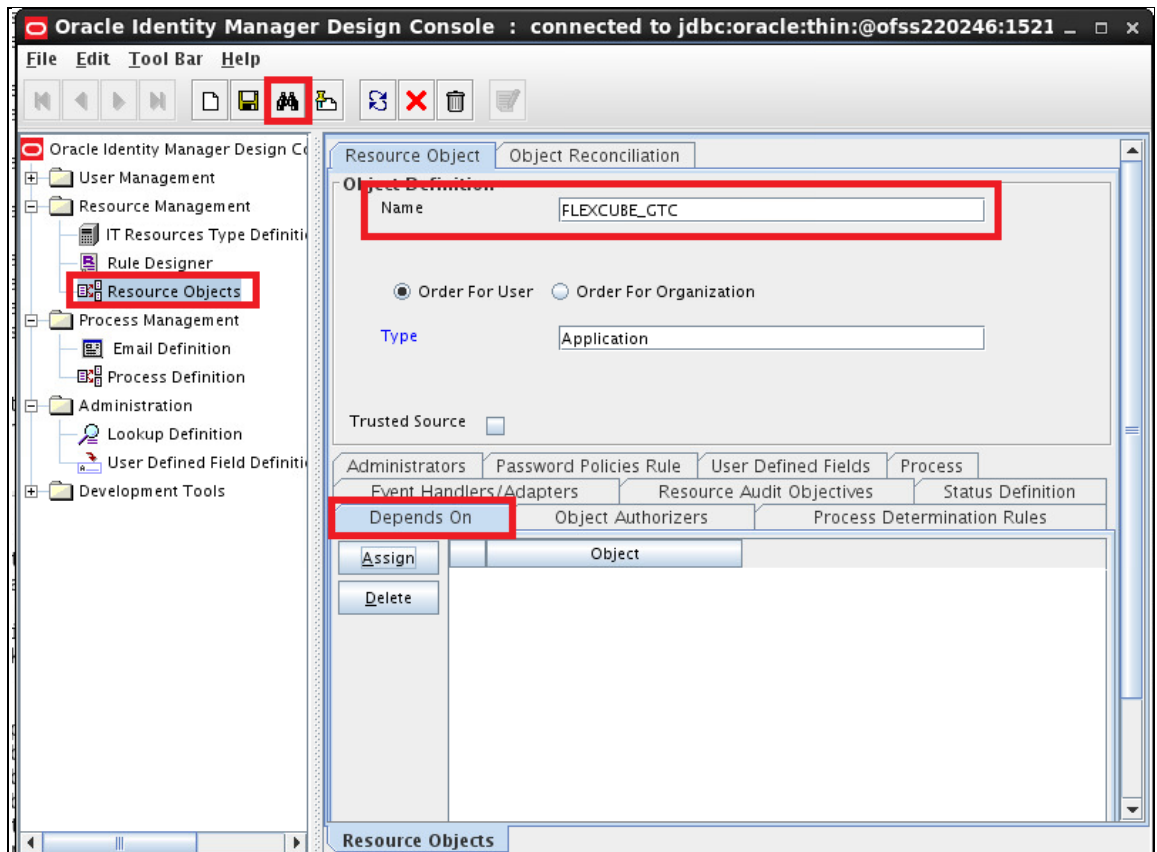

12. Select the OID User from the Unassigned Objects list. Click on the arrow pointed to Assignend objects.
13. Click on OK.This will move OID user resource to Assigned objects.

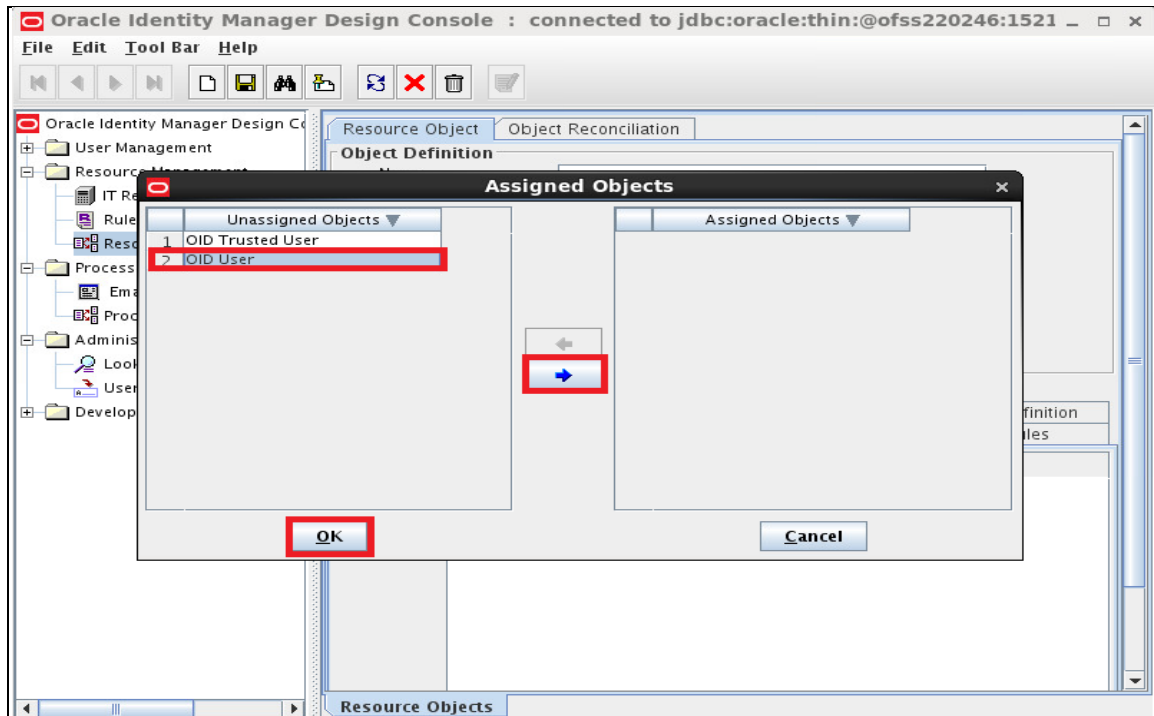

Ensure that OID User will be shown under Object.

14. Click on Save.

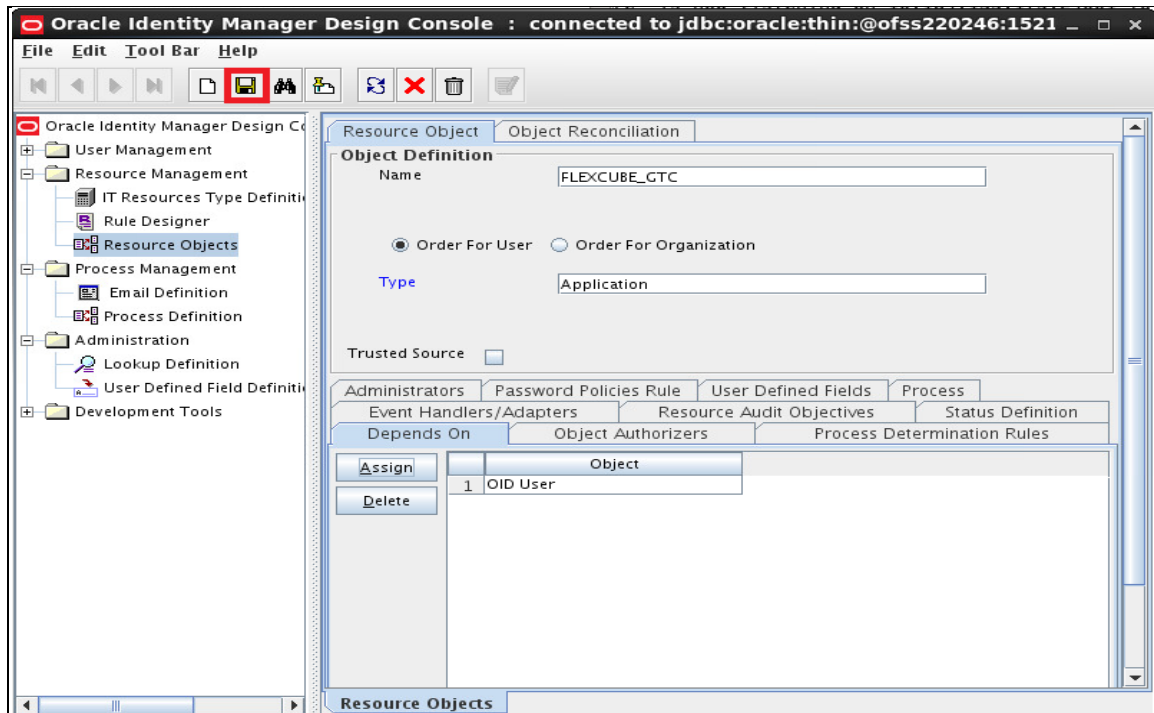

### Access Policy Creation for OID

1. Open the Oracle Identity Manager Administrative console. (Give the following URL in the browser: <http://<hostname>:<oimport>/sysadmin>)
2. Login to Administrative Console

3. Enter OIM administrator username/password and press Sign In.

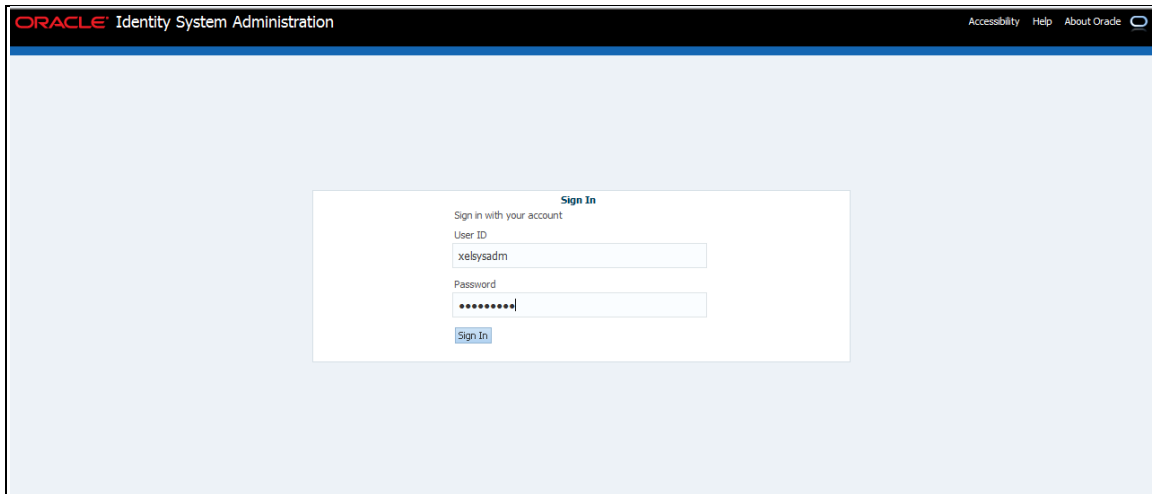

The screenshot shows the Oracle Identity System Administration web interface. At the top, the header includes the Oracle logo, the text "Identity System Administration", and navigation links for "Accessibility", "Help", and "About Oracle". The main content area is a light blue gradient with a central white box for the sign-in form. The form is titled "Sign In" and contains the following elements:

- Text: "Sign in with your account"
- Text: "User ID"
- Text input field: "xelsysadm"
- Text: "Password"
- Text input field: "\*\*\*\*\*"
- Submit button: "Sign In"



4. Click on Access Policies under Policies.

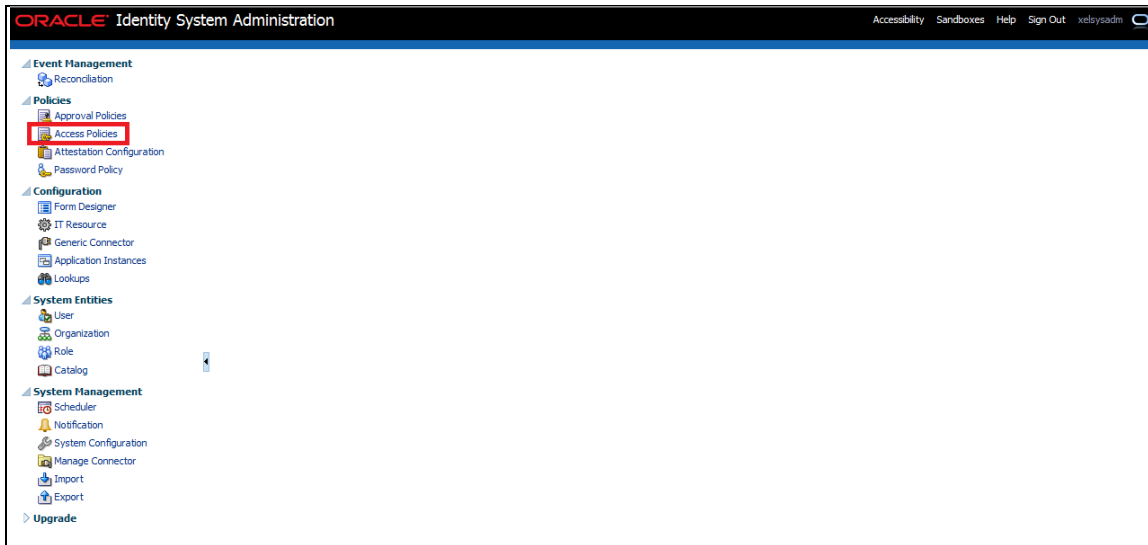

5. Click on Create Access Policy.

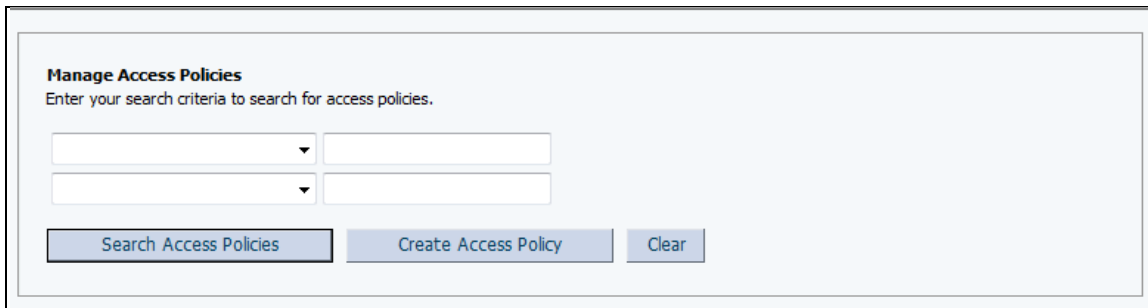

6. Enter the below details and Click on Continue

- Access Policy Name : OIDAccessPolicy
- Access Policy Description : OIDAccessPolicy
- Provision : Without Approval
- Retrofit Access Policy : Yes
- Priority : 1

**Create Access Policy**

1 2 3 4 5

**Step 1: Create Access Policy**

\* Indicates Required Field

Access Policy Name \*

Access Policy Description \*

Provision  Without Approval  With Approval

Retrofit Access Policy

Priority \*  Current Lowest Priority=0

7. Perform the below mentioned Operations and Click on Continue.

- Select OID User
- Click on Add Button

**Create Access Policy**

1 2 3 4 5

**Step 2: Select Resources**

Specify the resources to be provisioned by this access policy.

\* Indicates Required Field

Filter By

Results 1-2 of 2 First | Previous | Next | Last

<input type="checkbox"/>	Resource Name	<input type="button" value="Add &gt;&gt;"/>
<input type="checkbox"/>	FLEXCUBE_GTC	<input type="button" value="Add &gt;&gt;"/>
<input checked="" type="checkbox"/>	OID User	<input type="button" value="Add &gt;&gt;"/>

Selected:  
OID User

8. Click on Continue.

The screenshot shows a web-based wizard titled "Create Access Policy". At the top right, there are five numbered steps: 1, 2, 3, 4, and 5. Step 2 is highlighted with a blue circle and a downward-pointing arrow. Below the step indicators, the text reads "Step 2: Select Resources". A horizontal line follows. Below the line, the text says "The subsequent pages will guide you through providing the data to associate with the following resources you selected to be provisioned by this Access Policy:". Underneath, there is a bullet point labeled "OID User". At the bottom of the wizard, there are four buttons: "Exit", "<< Back", "Skip This Step", and "Continue >>".

9. Select the below Details and Click on Continue.

- Server : OID Server
- Container DN : cn=Users,dc=in,dc=oracle,dc=com
- Preferred Language : English
- Start Date : August 20, 2014 (Current Date)

**Create Access Policy**

1 2 3 4 5

**Step 2: Select Resources**

Provide the following process details for resource **OID User**:

\* Indicates a required field

User ID  
 Server  
 Password  
 First Name  
 Middle Name  
 Last Name  
 Common Name  
 Container DN  
 Department  
 Location  
 Telephone  
 Email ID  
 Preferred Language  
 Time Zone  
 Title  
 Start Date  
 End Date  
 manager

OID Server  
 Clear

cn=Users,dc=in,dc=orac  
 Clear

English  
 Clear

August 20, 2014  
 August 20, 2024

Exit << Back Set Additional Data Skip All Forms Continue >>

10. Click on Continue.

**Create Access Policy**

1 2 3 4 5

**Step 2: Select Revoke Or Disable Flag**

Select if the resources need to be revoked or disabled if the access policy no longer applies.

Resource Name	Revoke if no longer applies	Disable if no longer applies
OID User	<input checked="" type="radio"/>	<input type="radio"/>

Exit << Back Continue >>

11. Click on Continue.

**Create Access Policy**

1 2 3 4 5

**Step 3: Select Resources**

Specify the resources to be denied by this access policy.

\* Indicates Required Field

Filter By

Results 1-2 of 2 First | Previous | Next | Last

<input type="checkbox"/>	Resource Name
<input type="checkbox"/>	FLEXCUBE_GTC
<input type="checkbox"/>	OID User

First | Previous | Next | Last

**Selected:**

12. Select ALL USERS and Click on Continue.

**Create Access Policy**

1 2 3 4 5

**Step 4: Select Roles**

Specify roles for this access policy.

\* Indicates Required Field

Filter By

Results 1-5 of 5 First | Previous | Next | Last

<input type="checkbox"/>	Roles Name	Display Name
<input type="checkbox"/>	OPERATORS	OPERATORS
<input type="checkbox"/>	SELF OPERATORS	SELF OPERATORS
<input type="checkbox"/>	SYSTEM ADMINISTRATORS	SYSTEM ADMINISTRATORS
<input type="checkbox"/>	ALL USERS	ALL USERS
<input type="checkbox"/>	Administrators	Administrators

First | Previous | Next | Last

**Selected:**  
ALL USERS

13. Click on Create Access Policy.

The screenshot shows the 'Create Access Policy' wizard at Step 5: Verify Access Policy Information. The wizard has five steps, with Step 5 being the current one. The main content area is divided into several sections:

- Access Policy Information Provided:** A table showing the details of the access policy.

Access Policy Name	OIDAccessPolicy	<a href="#">Change</a>
Access Policy Description	OIDAccessPolicy	
With Approval	No	
Retrofit Access Policy	Yes	
Priority	1	
- Resources to be provisioned by this access policy:** A table listing resources.

Resource Name	Revoke if no longer applies	Disable if no longer applies	Process Forms	<a href="#">Change</a>
OID User	✓	✗	OID User <a href="#">Edit</a>	
- Resources to be denied by this access policy:** A message box stating: "You have not selected any resources to be denied by this access policy." with a [Change](#) link.
- Roles for this access policy:** A table listing roles.

Roles Name	<a href="#">Change</a>
ALL USERS	

At the bottom, there are three buttons: 'Exit', '<< Back', and 'Create Access Policy'.

14. Click on Scheduler under System Management.

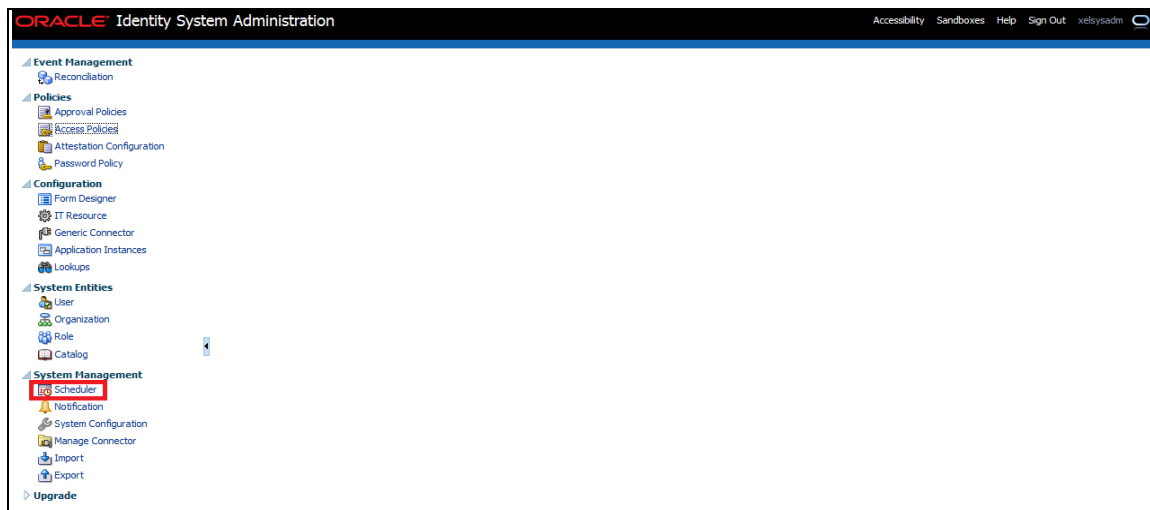

15. Click on Search shown below:

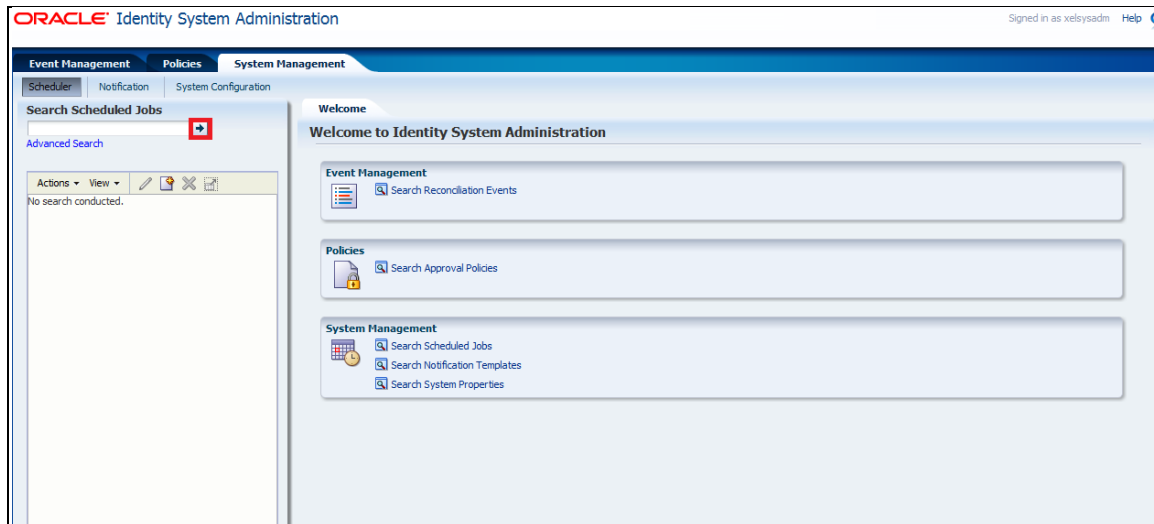

16. Select Evaluate User Policies.

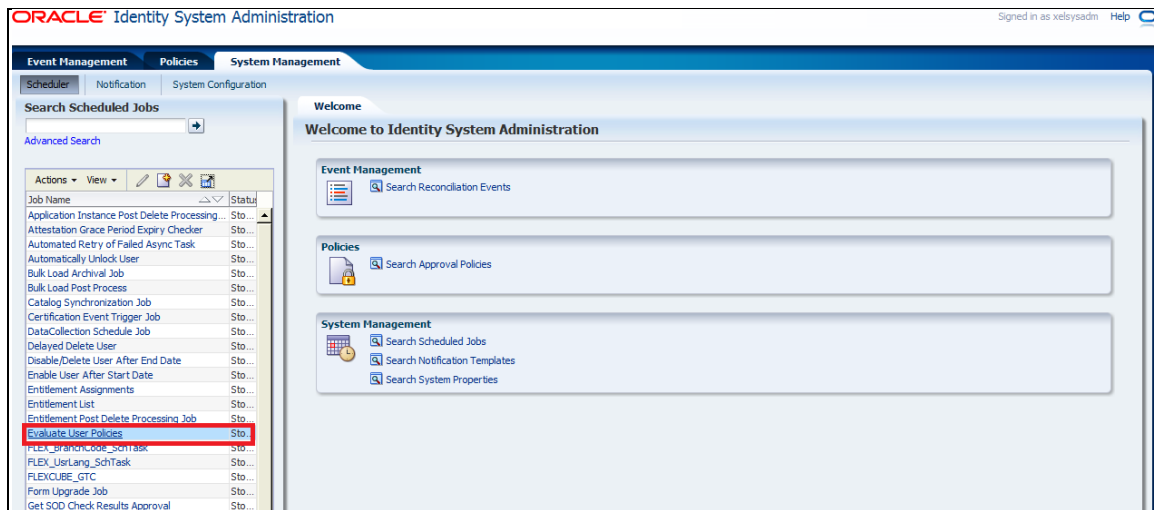

17. Change the Run Every under Job Periodic Setting.

18. Click on Apply.

Run Every to 1 mins will evaluate the New User Created in Oracle Identity Management Server against the access policies created. If the new user satisfied by the access policy then it will Provision the user to User Account. In this case it's Oracle Internet Directory.

Event Management Policies System Management

Scheduler Notification System Configuration

Search Scheduled Jobs

Advanced Search

Actions View [edit] [delete] [refresh]

Job Name	Status
Application Instance Post Delete Processing...	Sto...
Attestation Grace Period Expiry Checker	Sto...
Automated Retry of Failed Async Task	Sto...
Automatically Unlock User	Sto...
Bulk Load Archival Job	Sto...
Bulk Load Post Process	Sto...
Catalog Synchronization Job	Sto...
Certification Event Trigger Job	Sto...
DataCollection Schedule Job	Sto...
Delayed Delete User	Sto...
Disable/Delete User After End Date	Sto...
Enable User After Start Date	Sto...
Entitlement Assignments	Sto...
Entitlement List	Sto...
Entitlement Post Delete Processing Job	Sto...
Evaluate User Policies	Sto...
FLEX_BranchCode_SchTask	Sto...
FLEX_UsrLang_SchTask	Sto...
FLEXCUBE_GTC	Sto...
Form Upgrade Job	Sto...
Get SOD Check Results Approval	Sto...
Get SOD Check Results Provisioning	Sto...
Initiate Attestation Processes	Sto...
Issue Audit Messages Task	Sto...

Welcome Job Details

### Job Details : Evaluate User Policies

Apply Run Now Stop Enable Disable Refresh

\* Indicates required fields.

**Job Information**

Job Name: Evaluate User Policies  
Task: Evaluate User Policies

Schedule Type:  
 Periodic  
 Cron  
 Single  
 No pre-defined schedule

\* Start Date: August 20, 2014 3:32:54 (UTC+05:30) Calcutta - India Time (IT)

\* Retries: 5

**Job Periodic Settings**

Run every: [1] mins

**Job Status**

Current Status: Stopped  
Last Run Start: August 21, 2014 6:42:54 PM IST  
Last Run End: August 21, 2014 6:42:55 PM IST  
Next Scheduled Run: August 21, 2014 6:52:54 PM IST

**Parameters**

\* Batch Size: 500  
\* Number of Threads: 20  
Time Limit in mins: [ ]

**Job History**



---

## 6. Solution / Usage Guidelines

### 6.1 Working with OIM

#### 6.1.1 Creating a user in FLEXCUBE through OIM

To create a user in FLEXCUBE through OIM, first a user must be created in OIM itself. After creating a user in OIM, a user can be created in FLEXCUBE by assigning a resource named FLEXCUBE\_GTC.

Open the Oracle Identity Manager Administrative console. (Give the following URL in the browser: <http://<hostName>:<oimport>/identity>)

1. Login to Administrative Console
2. Enter OIM administrator username/password and press **Login**.

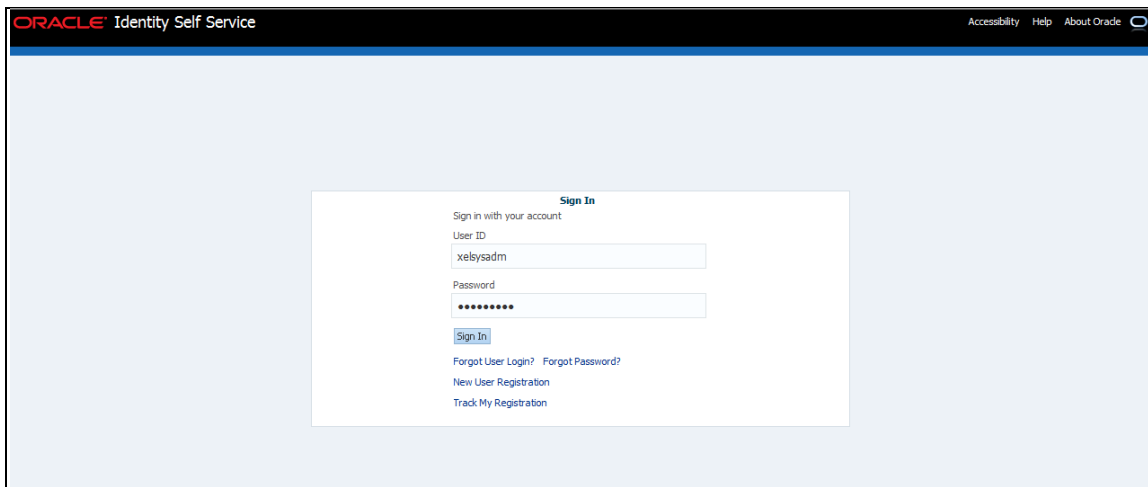

The screenshot shows the Oracle Identity Self Service Sign In page. The page has a header with the Oracle logo and the text "Identity Self Service". In the top right corner, there are links for "Accessibility", "Help", and "About Oracle". The main content area is a light blue background with a white sign-in form in the center. The form is titled "Sign In" and contains the following elements:

- A heading: "Sign in with your account"
- A "User ID" label followed by a text input field containing "xelbysadm".
- A "Password" label followed by a password input field with masked characters "\*\*\*\*\*".
- A "Sign In" button.
- Links for "Forgot User Login?" and "Forgot Password?".
- Links for "New User Registration" and "Track My Registration".

3. Click on Users under Administration.



4. Click on Create

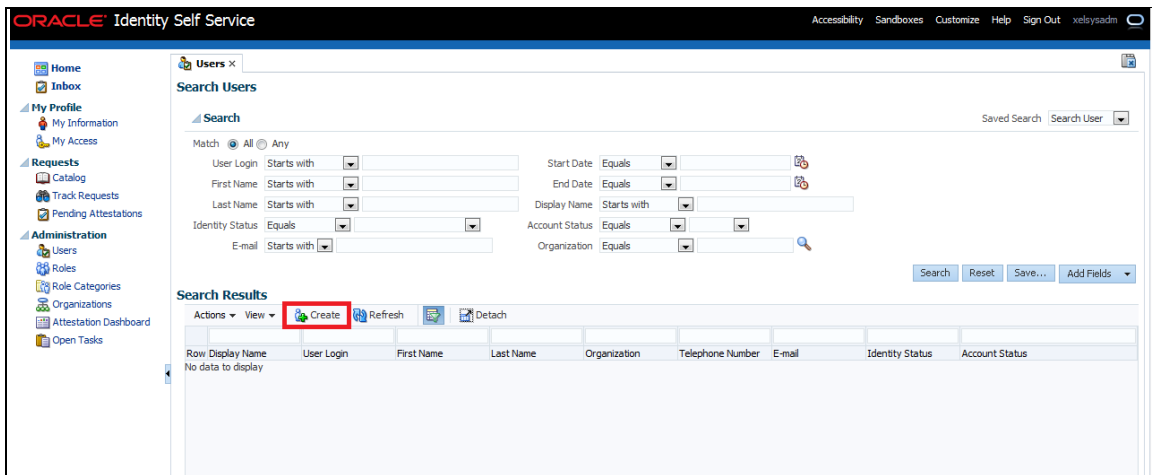

The Create User screen will get displayed.

Below are the mandatory fields, which needs to be entered to Create the User in Oracle Identity Manager

- First Name
- Last Name
- Organization
- User Type
- E-mail
- Display Name
- User Login
- Password
- Confirm Password
- Start Date

5. Click on Submit.

ORACLE Identity Self Service

Users x Create User x

Submit Cancel Save as Draft

**Create User**

**Justification and Effective Date**

Justification

Effective Date

**Basic Information**

First Name Nandhakumar

Middle Name

\* Last Name Vemban

E-mail nandhakumar.vemban@oracle.com

Manager

\* Organization Requests

\* User Type Full-Time Employee

Display Name Nandhakumar Vemban

**Account Settings**

User Login NVEMBAN

Password

\* Confirm Password

**Account Effective Dates**

Start Date 8/25/2014

End Date

**Provisioning Dates**

Provisioning Date

Deprovisioning Date

**Contact Information**

Telephone Number

Home Phone

Fax

Mobile

Pager

Home Postal Address

Postal Address

Postal Code

PO Box

State

Street

Country

On successful creation of user in OIM User Detail screen will get appeared.

ORACLE Identity Self Service Accessibility Sandboxes Customize Help Sign Out xebysadm

✔ User created successfully

Users x | **User Details : Nandhakuma...** x

**Nandhakumar Vemban**

Modify User Enable User Disable User Delete User Lock Account Unlock Account Reset Password

Attributes Roles Entitlements **Accounts** Direct Reports Organizations Admin Roles

Newly added resources will not appear until the following table is refreshed.

Actions View Request Accounts Request Entitlement Refresh Resource History Detach

Row	Application Instance	Resource	Account Name	Provisioned On	Status	Account Type	Request ID
No data to display							

**Administration**

- Users
- Roles
- Role Categories
- Organizations
- Attestation Dashboard
- Open Tasks

Wait for Time, which has been set to evaluate the user access policy in [5.1.6.2.2.15](#) and Click on Refresh.

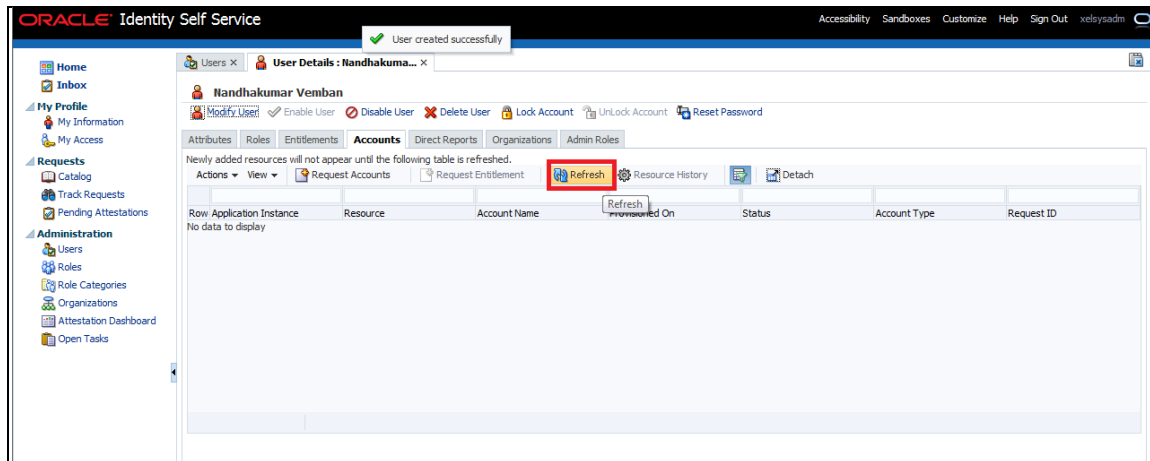

6. In the Accounts TAB, User will be provisioned with OID User Resource Type.

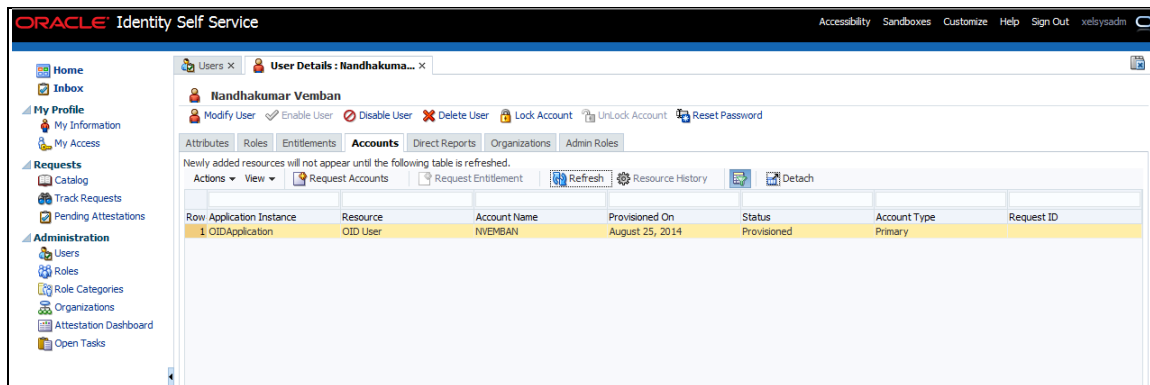

7. Click on Request Accounts.

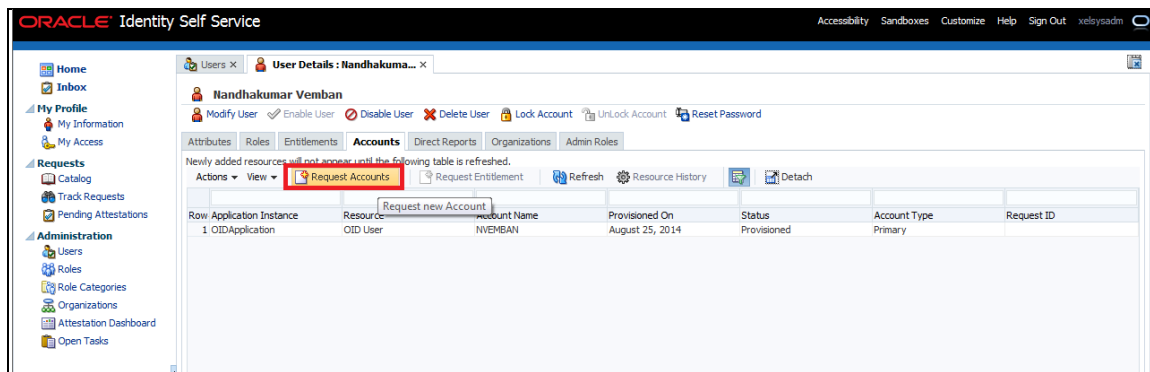

8. Click on  Add to Cart against FLEXCUBE\_GTC.

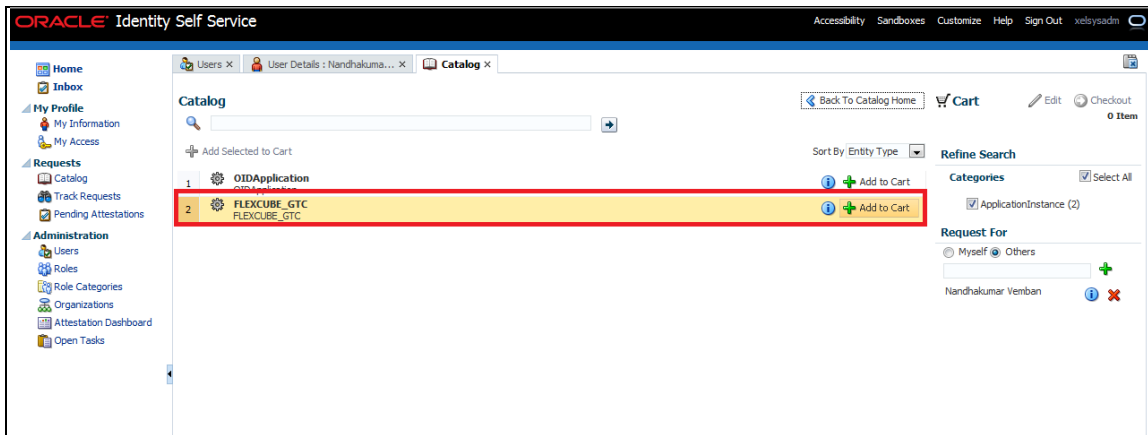

9. Click on  Checkout

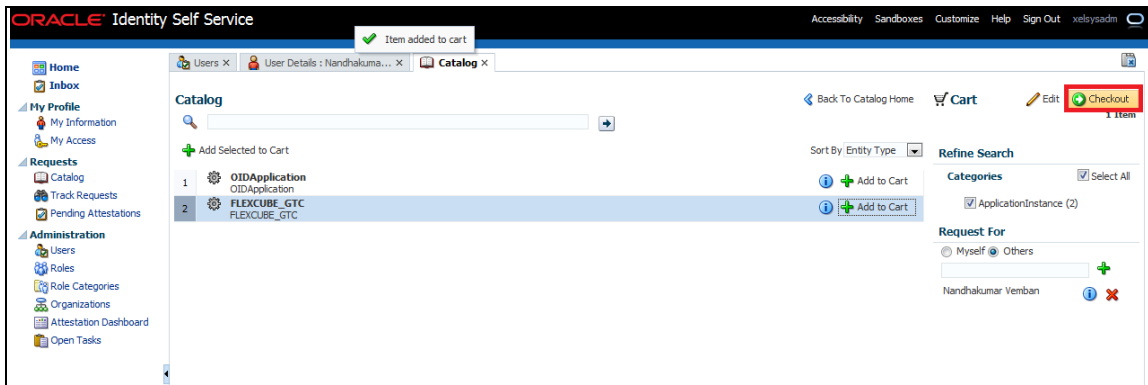

Following screen will appear like below:

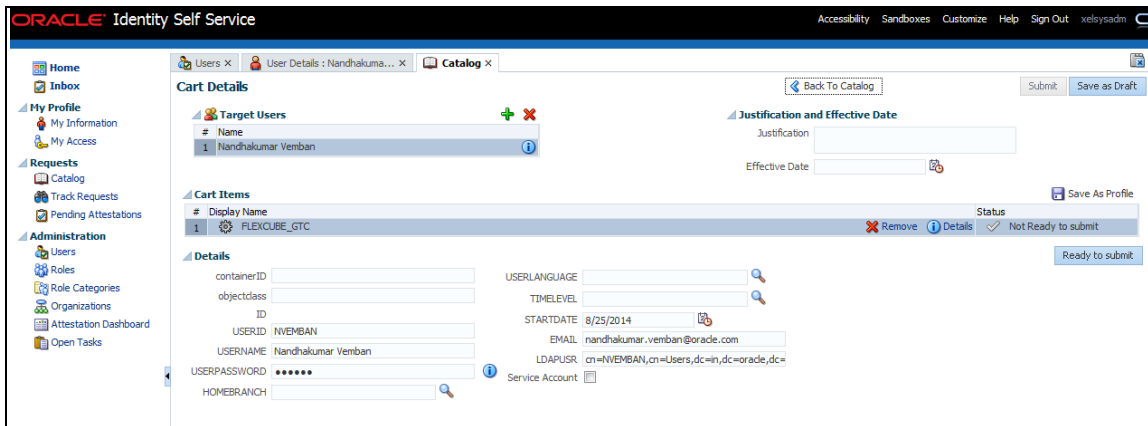

10. Enter the below details and Click on Ready to Submit.

- HOMEBRANCH
- USERLANGUAGE
- TIMELEVEL

In case like have a different FLEXCUBE USERID populated then it can be modified ( only during Request Account in FLEXCUBE), do not modify any other value, which is pre-populated in this screen.

Oracle Identity Self Service interface showing the 'Cart Details' page. The page displays user information and details for a request. The 'Details' section includes fields for containerID, objectclass, ID, USERID, USERNAME, USERPASSWORD, HOMEBRANCH, USERLANGUAGE, TIMELEVEL, STARTDATE, EMAIL, and LDAPUSR. A 'Ready to submit' button is visible at the bottom right.

11. Click on Submit.

Oracle Identity Self Service interface showing the 'Cart Details' page after submission. The page displays a success message: "Successfully Completed the operation." and a "Back To Catalog" button.

12. Click on Refresh under Accounts TAB.

If the status is provisioned then the User is created in the Target Application.

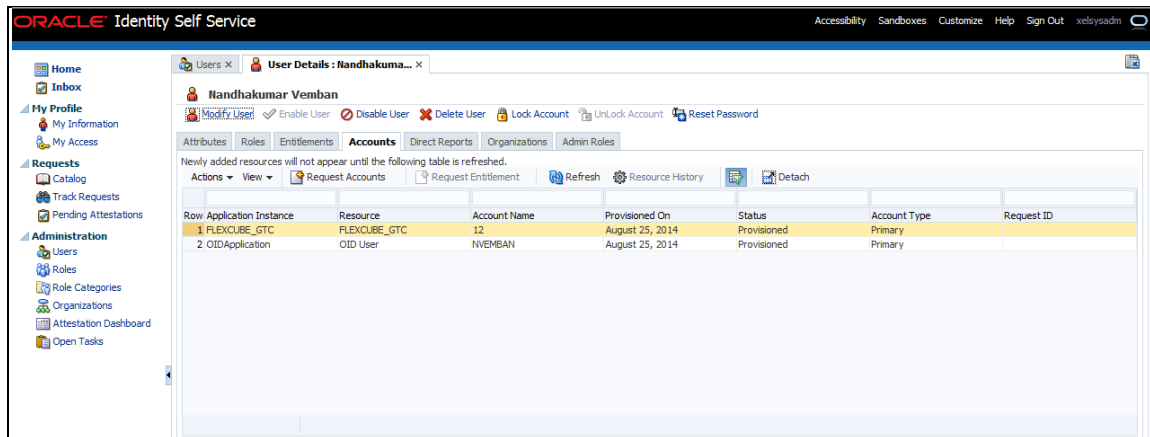

## 6.1.2 Modifying a user in FCUBS through OIM

1. Navigate to the Accounts TAB>>Select FLEXCUBE\_GTC >> Click on Modify Accounts.
2. After successful provisioning User Details like User Name, Time Level, User Language and Home Branch can be modified.
3. User Password, Email, LDAP User, Start Date Cannot be modified.

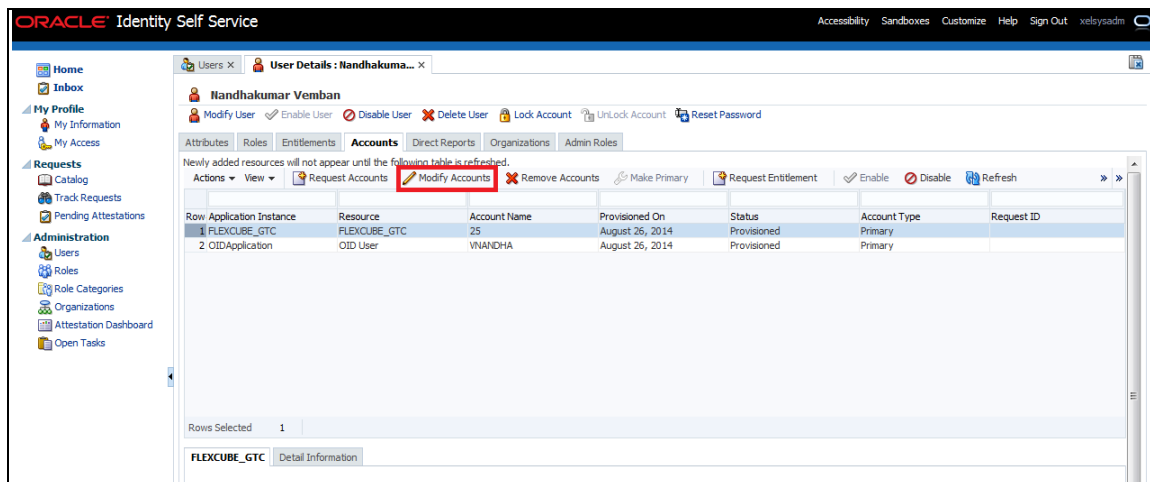

The following screen is displayed.

4. Modify the data (Any/All of User Name, Time Level, Home Branch and User Language).
5. Click on Ready to Submit.
6. Click on Submit.



ORACLE Identity Self Service Accessibility Sandboxes Customize Help Sign Out velsysadm

Users x User Details : Nandhakuma... x Modify Account x

**Modify Account** Submit Save as Draft

**Target Users**

#	Name	
1	Nandhakumar Vemban	<a href="#">i</a>

**Justification and Effective Date**

Justification

Effective Date

**Cart Items**

#	Display Name	Status
1	25@FLEXCLBE_GTC	Not Ready to submit

**Edit Account details** Ready to submit

containerID	<input type="text"/>	HOMEBRANCH	DISTBAGY
objectclass	<input type="text"/>	USERLANGUAGE	ENG
ID	<input type="text"/>	TIMELEVEL	9
USERID	VNANDHA	STARTDATE	8/25/2014
USERNAME	Nandhakumar Vemban	EMAIL	nandhakumar.vemban@oracle.com
USERPASSWORD	*****	LDAPUSR	cn=VNANDHA,cn=Users,dc=in,dc=oracle,dc=

The following screen is displayed.

7. Close the Screen.

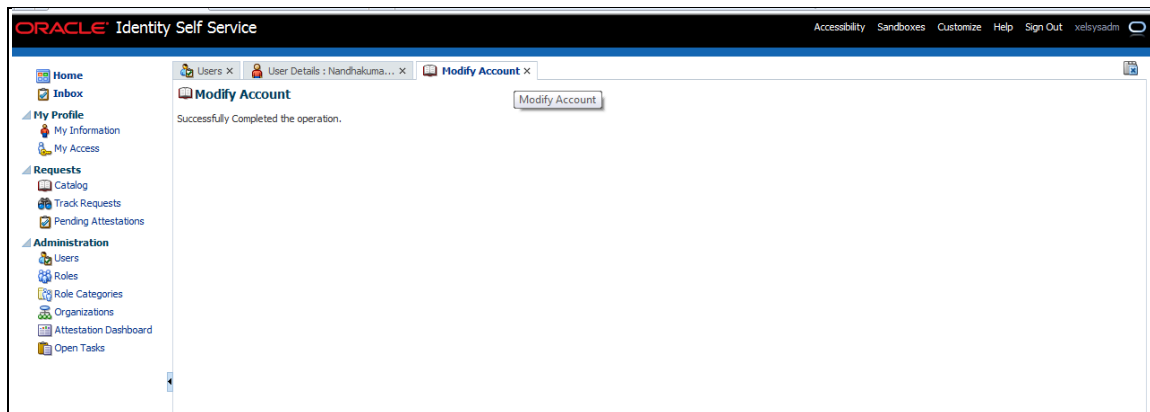

8. Navigate to the Accounts >> Select FLEXCUBE\_GTC >> Resource History

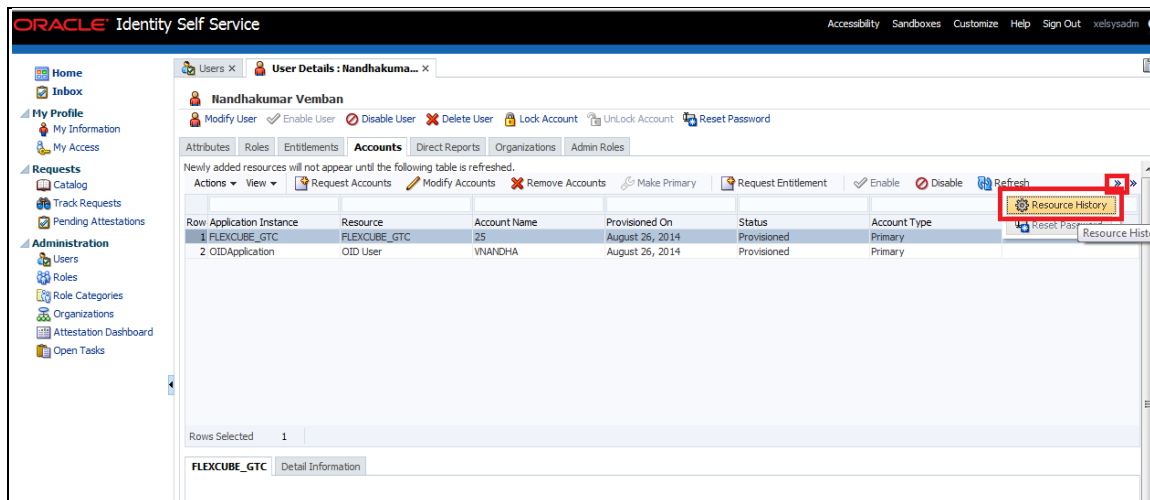

The following screen is displayed.

- Based on the modification done it will show the individual field change status (In case of more than one field like User Name, User Password changes it will show USERNAME Updated, HOMEBRANCH Updated etc.).

**User Detail >> Resource Profile >> Resource Provisioning Details**  
 The following are the provisioning tasks for the resource. You can also enable, disable, or revoke this resource from the user.

**FLEXCUBE\_GTC** provisioning details for **Nandhakumar Vemban[VNANDHA]**

Results 1-8 of 8 First | Previous | Next | Last

<u>Task Name</u>	<u>Task Status</u>	<u>Date Assigned</u>	<u>Assigned To</u>	<u>Retry</u>
System Validation	Completed	August 26, 2014	System Administrator [XELSYSADM]	<input type="checkbox"/>
HOMEBRANCH Updated	Completed	August 26, 2014	System Administrator [XELSYSADM]	<input type="checkbox"/>
Create User	Completed	August 26, 2014	System Administrator [XELSYSADM]	<input type="checkbox"/>
HOMEBRANCH Updated	Completed	August 26, 2014	System Administrator [XELSYSADM]	<input type="checkbox"/>

### 6.1.3 Disable/Remove Accounts in FCUBS through OIM

There is a slight difference between Disable and Remove Accounts option. If the account disabled then the same account can be enabled using the Enable option. If the account is Removed then the account cannot be enabled through OIM. But in FCUBS, both Disable and Remove option will close the existing user record.

Remove Accounts will show the Last Known Status

#### 6.1.3.1 Accounts>>Select FLEXCUBE\_GTC >>Click on Disable/Remove Accounts

**ORACLE Identity Self Service** Accessibility Sandboxes Customize Help Sign Out xelysadm

Users X **User Details : Nandhakuma...**

**Nandhakumar Vemban**  
 Modify User Enable User Disable User Delete User Lock Account Unlock Account Reset Password

Attributes Roles Entitlements **Accounts** Direct Reports Organizations Admin Roles

Newly added resources will not appear until the following table is refreshed.

Actions View Request Accounts Modify Accounts **Remove Accounts** Make Primary Request Entitlement Enable Disable Refresh

Row	Application Instance	Resource	Account Name	Provisioned On	Status	Account Type	Request ID
1	FLEXCUBE_GTC	FLEXCUBE_GTC	25	August 26, 2014	Provisioned	Primary	
2	OIDApplication	OID User	VNANDHA	August 26, 2014	Provisioned	Primary	

Rows Selected 1

**FLEXCUBE\_GTC** Detail Information

Name FLEXCUBE\_GTC  
 Display Name FLEXCUBE\_GTC

Disable Confirmation Screen will get displayed

10. Click on Submit.

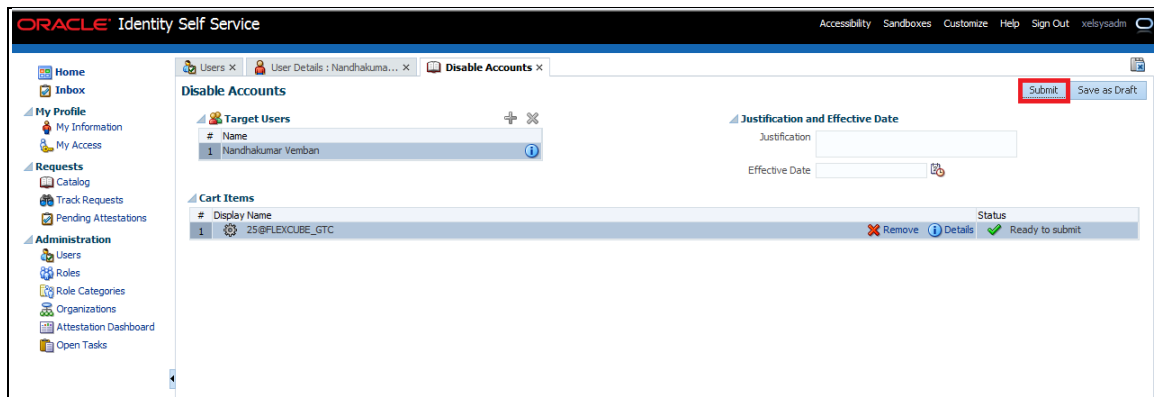

11. Go to Accounts Tab and Click on Refresh.

12. On successful processing, it will display the FLEXCUBE\_GTC status as Disabled.

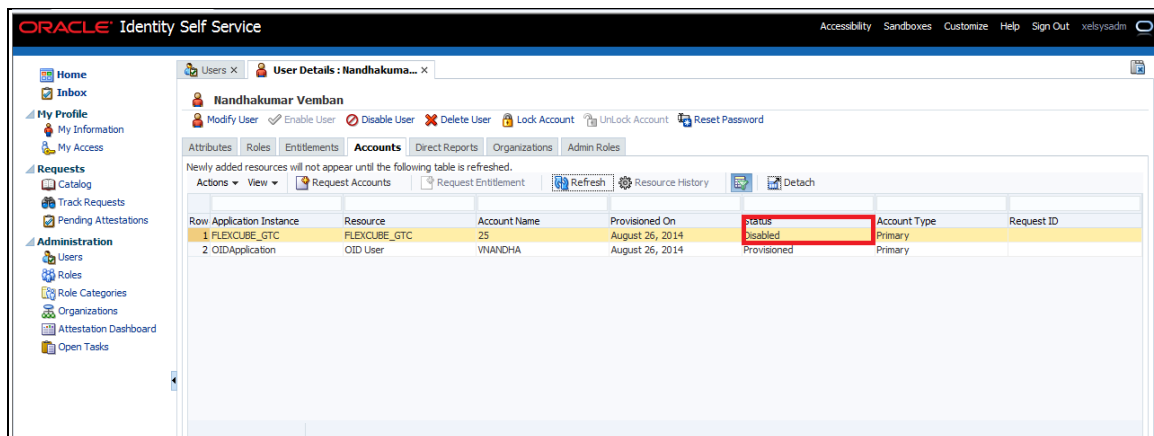

## 6.1.4 Enabling a Disabled user in FCUBS through OIM

1. Accounts>>Select FLEXCUBE\_GTC >>Click on Enable

Oracle Identity Self Service interface showing the 'Accounts' tab for user Nandhakumar Vemban. The table below shows the account details:

Row	Application Instance	Resource	Account Name	Provisioned On	Status	Account Type	Request ID
1	FLEXCUBE_GTC	FLEXCUBE_GTC	25	August 26, 2014	Disabled	Primary	
2	OIDApplication	OID User	WNANDHA	August 26, 2014	Provisioned	Primary	

2. Enable Confirmation Screen will get displayed and Click on Submit

Oracle Identity Self Service interface showing the 'Enable Accounts' confirmation screen. The 'Submit' button is highlighted with a red box.

3. Go to Accounts TAB and Click on Refresh.
4. On successful processing, it will display the FLEXCUBE\_GTC status as Enabled.

Oracle Identity Self Service interface showing the 'Accounts' tab for user Nandhakumar Vemban. The 'Refresh' button is highlighted with a red box. The table below shows the account details:

Row	Application Instance	Resource	Account Name	Provisioned On	Status	Account Type	Request ID
1	FLEXCUBE_GTC	FLEXCUBE_GTC	25	August 26, 2014	Enabled	Primary	
2	OIDApplication	OID User	WNANDHA	August 26, 2014	Provisioned	Primary	

## 6.1.5 Running Reconciliation in OIM

Copy the reconciliation staging file that is created by function id SMBOIMHF as EOD day activity to the OIM server's staging directory.

1. Login to OIM Admin Console and Click on Scheduler under System Management.

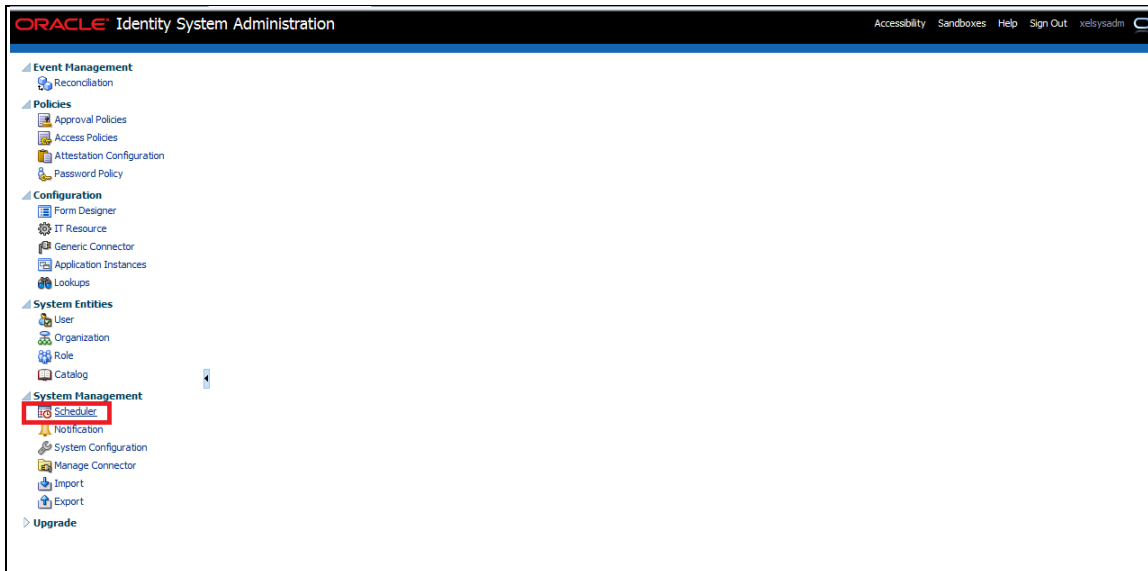

2. Under System Management tab and search for FLEXCUBE\_GTC Scheduled Job by clicking Search Button.

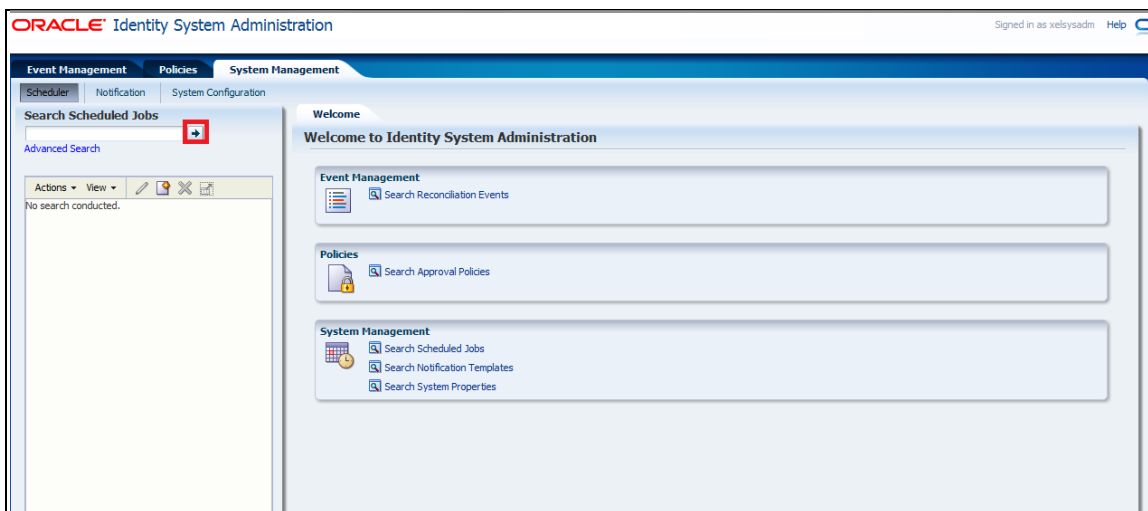

3. If the job is scheduled periodically, based on the frequency and scheduled time, system will automatically process the reconciliation. If it not scheduled, user can manually initiate the reconciliation process by clicking the Run Now button.
4. After running the process, click Refresh button to view the status of the initiated job. The job history section available in the screen will show whether the job is in progress or it is completed.

ORACLE Identity System Administration Signed in as xelsysadm Help

Event Management Policies System Management

Scheduler Notification System Configuration

Search Scheduled Jobs Advanced Search

Actions View [Icons]

Job Name	Status
Application Instanc...	Stopped
Attestation Grace...	Stopped
Automated Retry...	Stopped
Automatically Unlo...	Stopped
Bulk Load Archival...	Stopped
Bulk Load Post Pro...	Stopped
Catalog Synchroni...	Stopped
Certification Event...	Stopped
DataCollection Sch...	Stopped
Delayed Delete Use...	Stopped
Disable/Delete Use...	Stopped
Enable User After...	Stopped
Entitlement Assign...	Stopped
Entitlement List	Stopped
Entitlement Post D...	Stopped
Evaluate User Polc...	Stopped
FLEX_BranchCode...	Stopped
FLEX_UserLang_Sch...	Stopped
<b>FLEXCUBE_GTC</b>	Stopped
Form Upgrade Job	Stopped
Get SOD Check Re...	Stopped

Job Details : FLEXCUBE\_GTC Apply Run Now Stop Enable Disable Refresh

Job Information

Job Name: FLEXCUBE\_GTC  
 Task: FLEXCUBE\_GTC  
 \* Start Date: January 1, 1970 5:30:00 (UTC+05:30) Calcutta - India Time (IT)  
 \* Retries: 0

Schedule Type:  Periodic  Cron  Single  No pre-defined schedule

Job Periodic Settings

Run every: 1 days

Job Status

Current Status: Stopped  
 Last Run Start: August 22, 2014 12:30:10 PM IST  
 Last Run End: August 22, 2014 12:30:10 PM IST  
 Next Scheduled Run:

Parameters

Connector Name: FLEXCUBE  
 ITRResource: FLEXCUBE\_GTC

Run the job now

ORACLE Identity System Administration Signed in as xelsysadm Help

Event Management Policies System Management

Scheduler Notification System Configuration

Search Scheduled Jobs Advanced Search

Actions View [Icons]

Job Name	Status
Application Instanc...	Stopped
Attestation Grace...	Stopped
Automated Retry...	Stopped
Automatically Unlo...	Stopped
Bulk Load Archival...	Stopped
Bulk Load Post Pro...	Stopped
Catalog Synchroni...	Stopped
Certification Event...	Stopped
DataCollection Sch...	Stopped
Delayed Delete Use...	Stopped
Disable/Delete Use...	Stopped
Enable User After...	Stopped
Entitlement Assign...	Stopped
Entitlement List	Stopped
Entitlement Post D...	Stopped
Evaluate User Polc...	Stopped
FLEX_BranchCode...	Stopped
FLEX_UserLang_Sch...	Stopped
<b>FLEXCUBE_GTC</b>	Stopped
Form Upgrade Job	Stopped
Get SOD Check Re...	Stopped
Get SOD Check Re...	Stopped
Initiate Attestation...	Stopped
Issue Audit Messa...	Stopped
Job History Archival	Stopped
LDAPSync Post En...	Stopped
LDAPSync Post En...	Stopped
LDAPSync Post En...	Stopped
LDAPSync Post En...	Stopped

Job Details : FLEXCUBE\_GTC Apply Run Now Stop Enable Disable Refresh

Job Information

Job Name: FLEXCUBE\_GTC  
 Task: FLEXCUBE\_GTC  
 \* Start Date: January 1, 1970 5:30:00 (UTC+05:30) Calcutta - India Time (IT)  
 \* Retries: 0

Schedule Type:  Periodic  Cron  Single  No pre-defined schedule

Job Periodic Settings

Run every: 1 days Time between runs in mins/hrs/days

Job Status

Current Status: Stopped  
 Last Run Start: August 22, 2014 12:30:10 PM IST  
 Last Run End: August 22, 2014 12:30:10 PM IST  
 Next Scheduled Run:

Parameters

Connector Name: FLEXCUBE  
 ITRResource: FLEXCUBE\_GTC

Job History

Actions View Show error details

Start Time	End Time	Job Status	Execution Status
August 22, 2014 1...	August 22, 2014 1...	Stopped	Success

- To Check the Status of Reconciliation Process, Click on Event Management Tab and Click the Search button and Click on the Latest Event ID. The screen will show the reconciliation data and the user ID matched for the reconciliation.

Oracle Identity System Administration - Signed in as xelsysadm

Event Management | Policies | System Management

Reconciliation

Search Reconciliation Events

Advanced Search

Event ID: 1 | Profile Name: FLEXCUBE\_GTC | Key Fields: ANDY12

Event Details: ID 1

Event

Event ID: 1 | Date and Time: August 22, 2014 12:30:10 PM IST  
 Current Status: Update Succeeded | Job ID: 1671  
 Entity: Account | Resource Name: FLEXCUBE\_GTC  
 Type: Changelog | Profile Name: FLEXCUBE\_GTC  
 Key Fields: ANDY12 | Modifier ID: Internal User  
 Action Date: Action Date not specified | Retry Count: 5

Linked To

Linked User: **ANDY12 - Andy Rajagopalan** | Linked By: Rule Based Linking

Notes

Reconciliation Data

Attribute Name	Attribute Value	OIM Mapped Field
IT Resource2	4	IT Resource2
USERLANGUAGE	ENG	USERLANGUAGE
USERNAME	Anand R	USERNAME
TIMELEVEL	9	TIMELEVEL
HOMEBRANCH	FMG	HOMEBRANCH
STARTDATE	April 8, 2014 12:00:00	STARTDATE
USERID	ANDY12	USERID

In the Event details screen

- Check the Status: If it is "Update Succeeded" then it means the reconciliation process was able to find a matching user. It also shows the reconciliation data that has been affected.
- If the Liked User is "Not Liked to any user" then it means the reconciliation process was not able to find a matching user.

Oracle Identity System Administration - Signed in as xelsysadm

Event Management | Policies | System Management

Reconciliation

Search Reconciliation Events

Advanced Search

Event ID: 21 | Profile Name: FLEXCUBE\_GTC | Key Fields: WKUMAR

Event Details: ID 21

Event

Event ID: 21 | Date and Time: August 26, 2014 3:02:46 PM IST  
 Current Status: No User Match Found | Job ID: 4448  
 Entity: Account | Resource Name: FLEXCUBE\_GTC  
 Type: Changelog | Profile Name: FLEXCUBE\_GTC  
 Key Fields: WKUMAR | Modifier ID: Internal User  
 Action Date: Action Date not specified | Retry Count: 5

Linked To

Linked User: **Not linked to any user** | Linked By:

Notes

Reconciliation Data

Attribute Name	Attribute Value	OIM Mapped Field
IT Resource2	4	IT Resource2
USERLANGUAGE	ENG	USERLANGUAGE
USERNAME	Anand R	USERNAME
TIMELEVEL	9	TIMELEVEL
HOMEBRANCH	FMG	HOMEBRANCH
STARTDATE	April 8, 2014 12:00:00	STARTDATE
USERID	WKUMAR	USERID

Lists all event data



---

## 7. Reference

Document Number	Title
1	<a href="#">Oracle Identity Manager Document.</a>
2	<a href="#">SPML specification Document.</a>

## 8. Appendix

### 8.1 Data Source Creation

1. Open the application server console in the browser by typing Console URL of Weblogic application server

<http://<hostname>:<port>/console/>

2. Login to Administrative Console
3. Enter Weblogic administrator username/password and press Login.

The screenshot shows the Oracle WebLogic Server 11g Administration Console login interface. The page has a blue gradient background with the text 'ORACLE WebLogic Server® 11g Administration Console' in the top left. A large, faint '11g' watermark is visible in the center. On the right side, there is a white login box titled 'Welcome'. Inside the box, it says 'Log in to work with the WebLogic Server domain'. Below this, there are two input fields: 'Username:' with the value 'weblogic' and 'Password:' with a masked password of ten dots. A red 'Login' button is located at the bottom right of the login box. At the bottom of the page, there is a dark blue footer containing the following text: 'WebLogic Server Version: 10.3.5.0. Copyright © 1996, 2010, Oracle and/or its affiliates. All rights reserved. Oracle is a registered trademark of Oracle Corporation and/or its affiliates. Other names may be trademarks of their respective owners.'

4. Expand Services and click on Data Sources as shown in below screen:

**ORACLE WebLogic Server® Administration Console**

Home > Summary of JDBC Data Sources

**Summary of JDBC Data Sources**

**Configuration** | Monitoring

A JDBC data source is an object bound to the JNDI tree that provides database connectivity through a pool of JDBC connections. Applications can look up a data source on the JNDI tree and then borrow a database connection from a data source.

This page summarizes the JDBC data source objects that have been created in this domain.

**Customize this table**

**Data Sources (Filtered - More Columns Exist)**

Click the **Lock & Edit** button in the Change Center to activate all the buttons on this page.

Name	Type	JNDI Name	Targets
EDNDataSource	Generic	jdbc/EDNDataSource	soa_server1
EDNLocalTxDataSource	Generic	jdbc/EDNLocalTxDataSource	soa_server1
fcjDevDS	Generic	jdbc/fcjDevDS	Applications
fcjdevDS11	Generic	jdbc/fcjdevDS11	Applications
fcjdevDS120	Generic	jdbc/fcjdevDS120	Applications
FCUBS	Generic	jdbc/fcjdevDS	AdminServer, Applications
FCUBS120_XA	Generic	jdbc/fcjdevDS120_XA	Applications
FCUBSScheduler	Generic	jdbc/fcjSchedulerDS	Applications
jdbc/registryDS	Generic	jdbc/registryDS	wls_ods1, wls_of1, osr_server1
mds-om	Generic	jdbc/mds/MDS_REPOS	om_server1

Showing 1 to 10 of 19 Previous | Next

5. Click on Lock & Edit as shown below.

**ORACLE WebLogic Server® Administration Console**

Home > Summary of JDBC Data Sources

**Summary of JDBC Data Sources**

**Configuration** | Monitoring

A JDBC data source is an object bound to the JNDI tree that provides database connectivity through a pool of JDBC connections. Applications can look up a data source on the JNDI tree and then borrow a database connection from a data source.

This page summarizes the JDBC data source objects that have been created in this domain.

**Customize this table**

**Data Sources (Filtered - More Columns Exist)**

Click the **Lock & Edit** button in the Change Center to activate all the buttons on this page.

Name	Type	JNDI Name	Targets
EDNDataSource	Generic	jdbc/EDNDataSource	soa_server1
EDNLocalTxDataSource	Generic	jdbc/EDNLocalTxDataSource	soa_server1
fcjDevDS	Generic	jdbc/fcjDevDS	Applications
fcjdevDS11	Generic	jdbc/fcjdevDS11	Applications
fcjdevDS120	Generic	jdbc/fcjdevDS120	Applications
FCUBS	Generic	jdbc/fcjdevDS	AdminServer, Applications
FCUBS120_XA	Generic	jdbc/fcjdevDS120_XA	Applications
FCUBSScheduler	Generic	jdbc/fcjSchedulerDS	Applications
jdbc/registryDS	Generic	jdbc/registryDS	wls_ods1, wls_of1, osr_server1
mds-om	Generic	jdbc/mds/MDS_REPOS	om_server1

Showing 1 to 10 of 19 Previous | Next

6. Expand New and click on Generic Data Source.

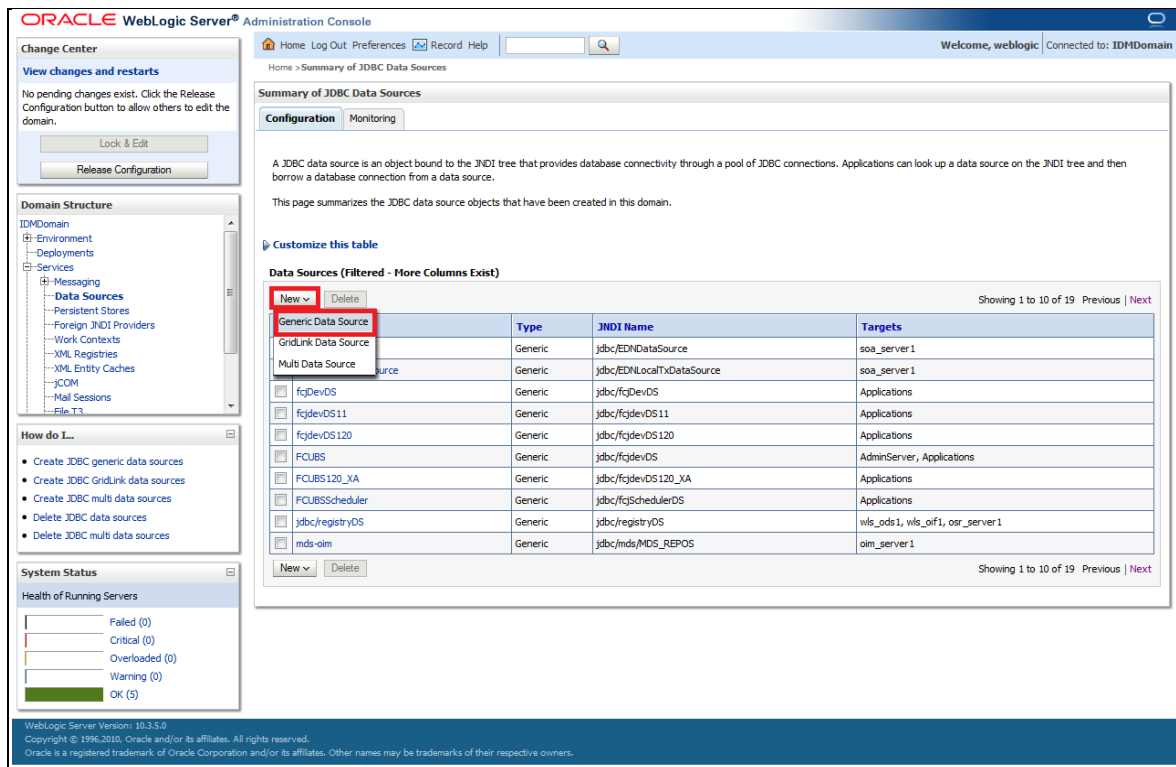

The following screen will get displayed.

Enter the Data Source Name and JNDI Name as mentioned in the <FCUBS Release Name>\ADAPTERS\OIM\FCUBSLOVAdService\config\lookup\_prop.xml → value of the key FCUBS\_CON\_POOLNAME.

For example value of the key FCUBS\_CON\_POOLNAME is OIM then:

Name	OIM
JNDI Name	jdbc/OIM
Database Type	Oracle

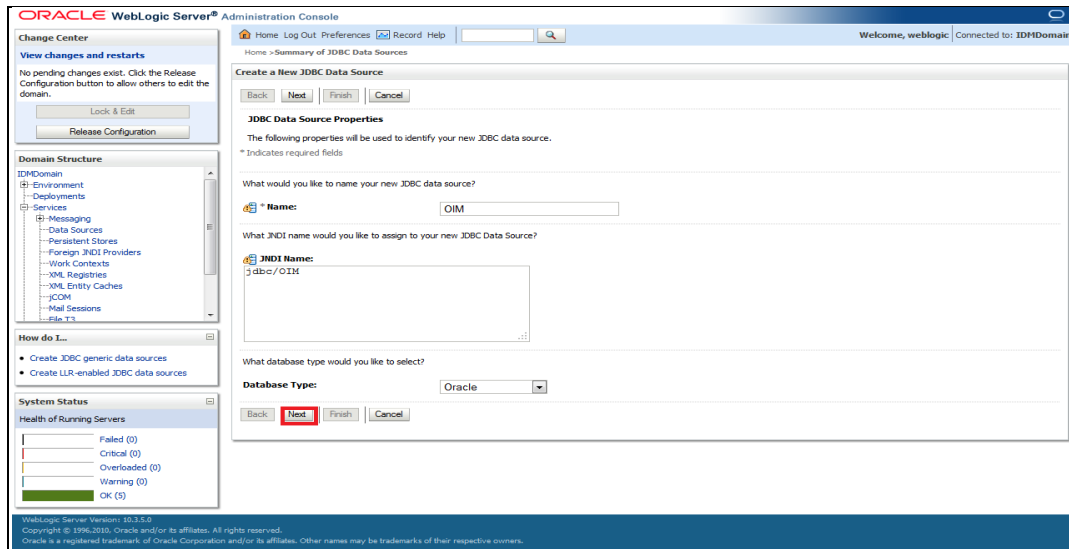

The following screen will get displayed. Select Database Driver as Oracle's Driver (Thin) for Instance connections: Versions 9.0.1 and later. Click on Next.

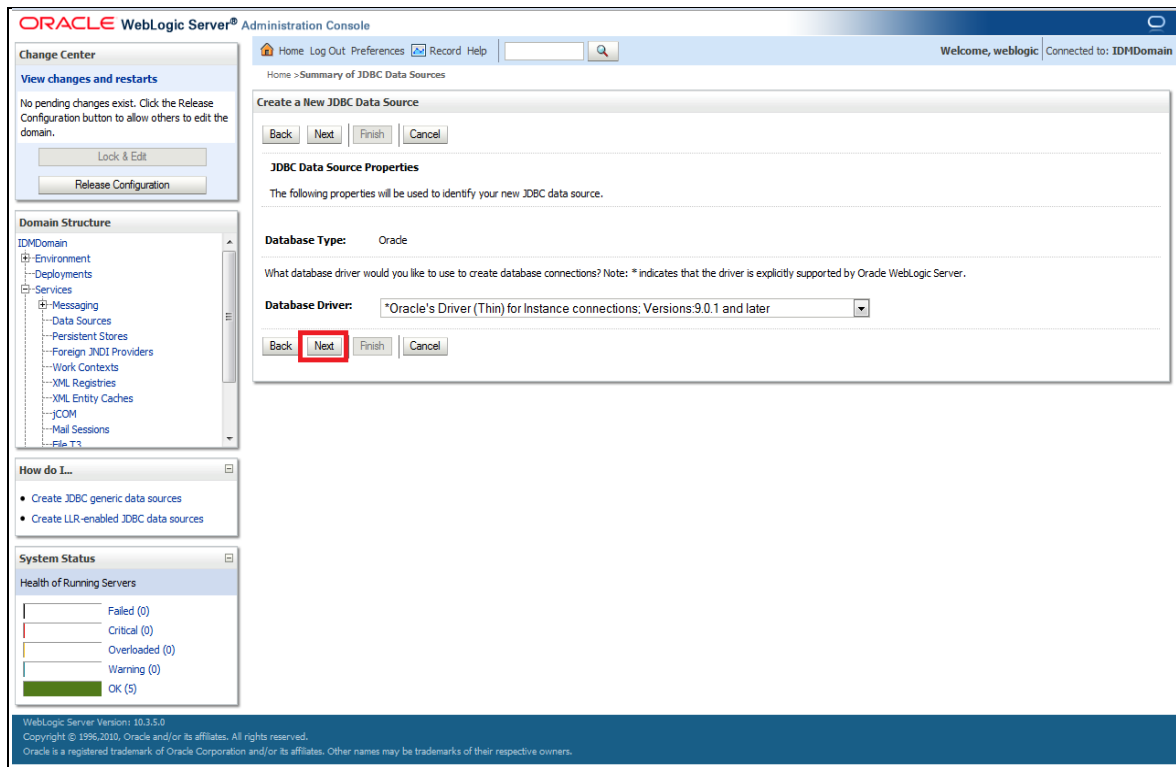

We get the following screen in which un-check Supports Global Transactions and click on Next.

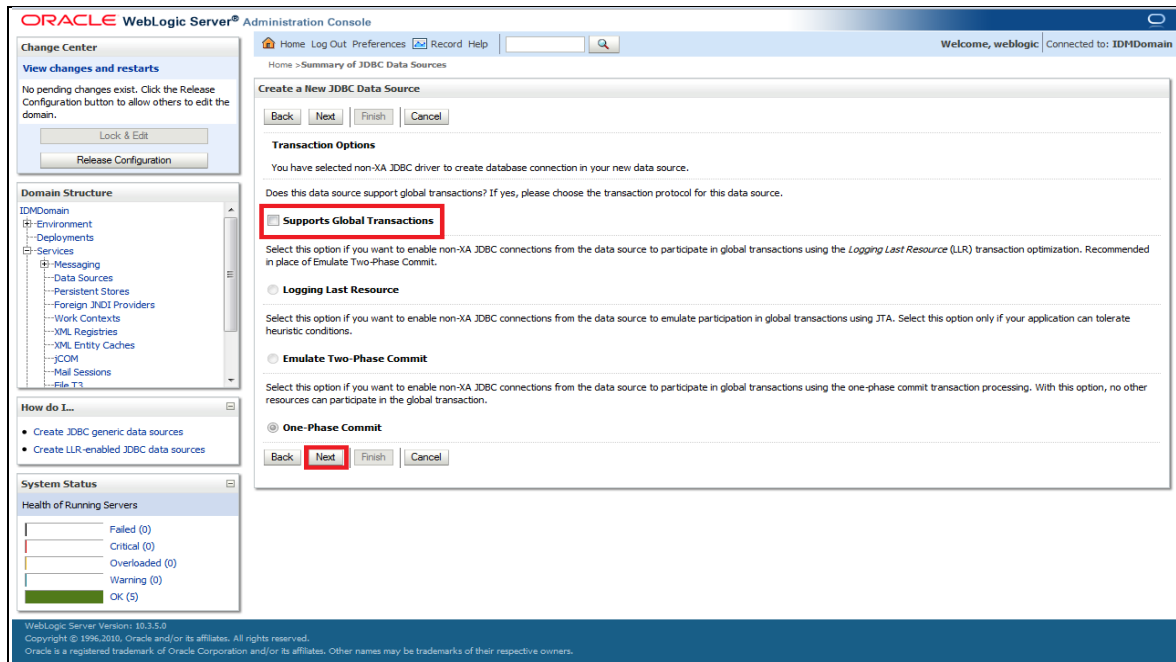

The following screen will get displayed. Enter the Database Name, Host Name, Port, Database User Name, Password and Confirm Password. Click on Next.

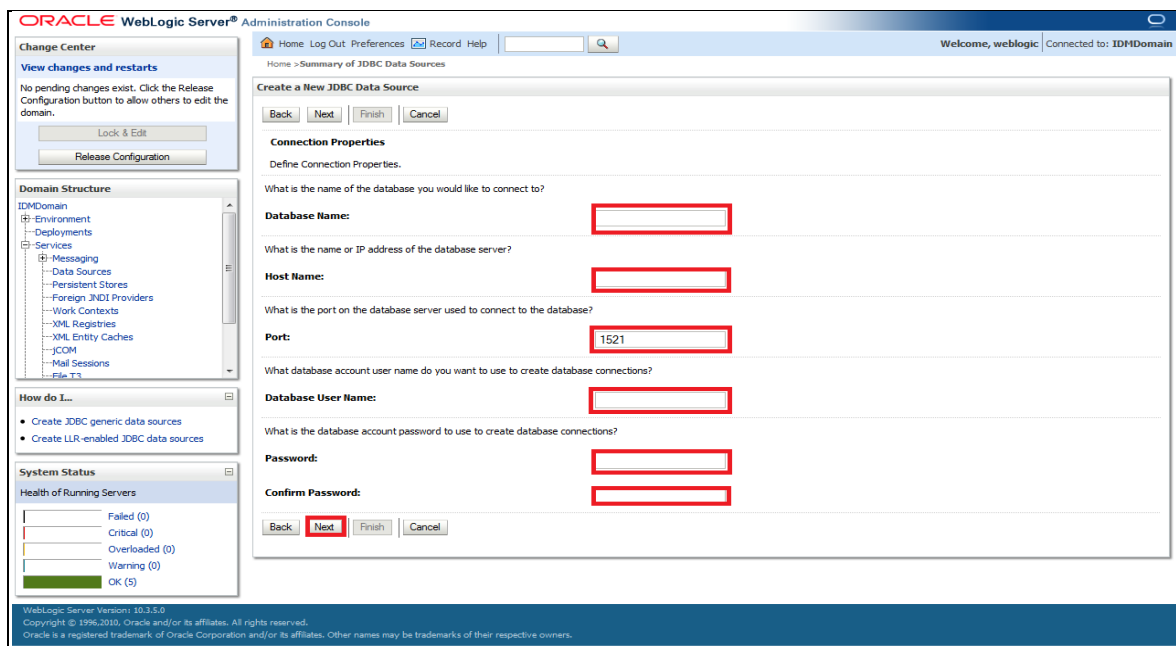

The following screen will get displayed. Click on 'Test Configuration'.

It will display "Connection test succeeded" as shown below. If it is not getting displayed then verify the correctness of all data source properties entered. Click on Finish button.

**ORACLE WebLogic Server® Administration Console**

Home Log Out Preferences Record Help Welcome, weblogic Connected to: IDHDomain

Home > Summary of JDBC Data Sources

Messages  
 ✓ Connection test succeeded

Create a New JDBC Data Source

Test Configuration Back Next Finish Cancel

**Test Database Connection**

Test the database availability and the connection properties you provided.

What is the full package name of JDBC driver class used to create database connections in the connection pool?  
(Note that this driver class must be in the classpath of any server to which it is deployed.)

Driver Class Name: oracle.jdbc.OracleDriver

What is the URL of the database to connect to? The format of the URL varies by JDBC driver.

URL: jdbc:oracle:thin:@10.10.10.10:1521:orcl

What database account user name do you want to use to create database connections?

Database User Name: DAY0114

What is the database account password to use to create database connections?  
(Note: for secure password management, enter the password in the Password field instead of the Properties field below)

Password: ●●●●●●●●

Confirm Password: ●●●●●●●●

What are the properties to pass to the JDBC driver when creating database connections?

Properties:  
 user=DAY0114

The set of driver properties whose values are derived at runtime from the named system property.

**Change Center**  
 View changes and restarts  
 No pending changes exist. Click the Release Configuration button to allow others to edit the domain.  
 Lock & Edit  
 Release Configuration

**Domain Structure**

IDHDomain  
 Environment  
 Deployments  
 Services  
 Messaging  
 Data Sources  
 Persistent Stores  
 Foreign JNDI Providers  
 Work Contexts  
 XML Registries  
 XML Entity Caches  
 JCOM  
 Mail Sessions  
 File T...

**How do I...**

- Create JDBC generic data sources
- Create LLR-enabled JDBC data sources

**System Status**

Health of Running Servers

Failed	(0)
Critical	(0)
Overloaded	(0)
Warning	(0)
OK	(5)

The following screen will get displayed. Click on Activate Changes.

The screenshot shows the Oracle WebLogic Server Administration Console interface. The main content area displays the 'Summary of JDBC Data Sources' page, which includes a table of data sources. On the left sidebar, the 'Change Center' section is visible, with the 'Activate Changes' button highlighted by a red rectangle. Below the table, there is a 'System Status' section showing the health of running servers.

**Change Center**  
View changes and restarts  
Pending changes exist. They must be activated to take effect.  
**Activate Changes**  
Undo All Changes

**Domain Structure**  
IDMDomain  
Environment  
Deployments  
Services  
Messaging  
Data Sources  
Persistent Stores  
Foreign JNDI Providers  
Work Contexts  
XML Registries  
XML Entity Caches  
JCOM  
Mail Sessions  
File Tr

**How do I...**  
• Create JDBC generic data sources  
• Create JDBC GndLink data sources  
• Create JDBC multi data sources  
• Delete JDBC data sources  
• Delete JDBC multi data sources

**System Status**  
Health of Running Servers  
Failed (0)  
Critical (0)  
Overloaded (0)  
Warning (0)  
OK (5)

**Summary of JDBC Data Sources**  
Configuration | Monitoring  
A JDBC data source is an object bound to the JNDI tree that provides database connectivity through a pool of JDBC connections. Applications can look up a data source on the JNDI tree and then borrow a database connection from a data source.  
This page summarizes the JDBC data source objects that have been created in this domain.  
Customize this table  
Data Sources (Filtered - More Columns Exist)  
Showing 1 to 10 of 20 Previous | Next

Name	Type	JNDI Name	Targets
EDNDataSource	Generic	jdbc/EDNDataSource	soa_server 1
EDNLocalTxDataSource	Generic	jdbc/EDNLocalTxDataSource	soa_server 1
fgDevDS	Generic	jdbc/fgDevDS	Applications
fgdevDS11	Generic	jdbc/fgdevDS11	Applications
fgdevDS120	Generic	jdbc/fgdevDS120	Applications
FCUBS	Generic	jdbc/fgdevDS	AdminServer, Applications
FCUBS120_XA	Generic	jdbc/fgdevDS120_XA	Applications
FCUBSScheduler	Generic	jdbc/fgSchedulerDS	Applications
jdbc/registryDS	Generic	jdbc/registryDS	wls_ods1, wls_of1, oas_server 1
mds-om	Generic	jdbc/mds/MDS_REPOS	om_server 1

Showing 1 to 10 of 20 Previous | Next

WebLogic Server Version: 10.3.5.0  
Copyright © 1996-2010, Oracle and/or its affiliates. All rights reserved.  
Oracle is a registered trademark of Oracle Corporation and/or its affiliates. Other names may be trademarks of their respective owners.





Oracle Identity Manager Integration Implementation Guide  
[February] [2016]  
Version 12.0.3.1.4

Oracle Financial Services Software Limited  
Oracle Park  
Off Western Express Highway  
Goregaon (East)  
Mumbai, Maharashtra 400 063  
India

Worldwide Inquiries:  
Phone: +91 22 6718 3000  
Fax: +91 22 6718 3001  
[www.oracle.com/financialservices/](http://www.oracle.com/financialservices/)

Copyright © [2007], [2014], Oracle and/or its affiliates. All rights reserved.

Oracle and Java are registered trademarks of Oracle and/or its affiliates. Other names may be trademarks of their respective owners.

**U.S. GOVERNMENT END USERS:** Oracle programs, including any operating system, integrated software, any programs installed on the hardware, and/or documentation, delivered to U.S. Government end users are "commercial computer software" pursuant to the applicable Federal Acquisition Regulation and agency-specific supplemental regulations. As such, use, duplication, disclosure, modification, and adaptation of the programs, including any operating system, integrated software, any programs installed on the hardware, and/or documentation, shall be subject to license terms and license restrictions applicable to the programs. No other rights are granted to the U.S. Government.

This software or hardware is developed for general use in a variety of information management applications. It is not developed or intended for use in any inherently dangerous applications, including applications that may create a risk of personal injury. If you use this software or hardware in dangerous applications, then you shall be responsible to take all appropriate failsafe, backup, redundancy, and other measures to ensure its safe use. Oracle Corporation and its affiliates disclaim any liability for any damages caused by use of this software or hardware in dangerous applications.

This software and related documentation are provided under a license agreement containing restrictions on use and disclosure and are protected by intellectual property laws. Except as expressly permitted in your license agreement or allowed by law, you may not use, copy, reproduce, translate, broadcast, modify, license, transmit, distribute, exhibit, perform, publish or display any part, in any form, or by any means. Reverse engineering, disassembly, or decompilation of this software, unless required by law for interoperability, is prohibited.

The information contained herein is subject to change without notice and is not warranted to be error-free. If you find any errors, please report them to us in writing.

This software or hardware and documentation may provide access to or information on content, products and services from third parties. Oracle Corporation and its affiliates are not responsible for and expressly disclaim all warranties of any kind with respect to third-party content, products, and services. Oracle Corporation and its affiliates will not be responsible for any loss, costs, or damages incurred due to your access to or use of third-party content, products, or services.