

Messaging System User Guide

# Oracle FLEXCUBE Universal Banking

Release 12.87.03.0.0

Part No. E88027-01

June 2017

Messaging System User Guide  
June 2017  
Oracle Financial Services Software Limited

Oracle Park

Off Western Express Highway  
Goregaon (East)  
Mumbai, Maharashtra 400 063  
India

Worldwide Inquiries:

Phone: +91 22 6718 3000

Fax: +91 22 6718 3001

[www.oracle.com/financialservices/](http://www.oracle.com/financialservices/)

Copyright © 2007, 2017, Oracle and/or its affiliates. All rights reserved.

Oracle and Java are registered trademarks of Oracle and/or its affiliates. Other names may be trademarks of their respective owners.

U.S. GOVERNMENT END USERS: Oracle programs, including any operating system, integrated software, any programs installed on the hardware, and/or documentation, delivered to U.S. Government end users are "commercial computer software" pursuant to the applicable Federal Acquisition Regulation and agency-specific supplemental regulations. As such, use, duplication, disclosure, modification, and adaptation of the programs, including any operating system, integrated software, any programs installed on the hardware, and/or documentation, shall be subject to license terms and license restrictions applicable to the programs. No other rights are granted to the U.S. Government.

This software or hardware is developed for general use in a variety of information management applications. It is not developed or intended for use in any inherently dangerous applications, including applications that may create a risk of personal injury. If you use this software or hardware in dangerous applications, then you shall be responsible to take all appropriate failsafe, backup, redundancy, and other measures to ensure its safe use. Oracle Corporation and its affiliates disclaim any liability for any damages caused by use of this software or hardware in dangerous applications.

This software and related documentation are provided under a license agreement containing restrictions on use and disclosure and are protected by intellectual property laws. Except as expressly permitted in your license agreement or allowed by law, you may not use, copy, reproduce, translate, broadcast, modify, license, transmit, distribute, exhibit, perform, publish or display any part, in any form, or by any means. Reverse engineering, disassembly, or decompilation of this software, unless required by law for interoperability, is prohibited.

The information contained herein is subject to change without notice and is not warranted to be error-free. If you find any errors, please report them to us in writing.

This software or hardware and documentation may provide access to or information on content, products and services from third parties. Oracle Corporation and its affiliates are not responsible for and expressly disclaim all warranties of any kind with respect to third-party content, products, and services. Oracle Corporation and its affiliates will not be responsible for any loss, costs, or damages incurred due to your access to or use of third-party content, products, or services.

---

# Contents

<b>1. Preface .....</b>	<b>1-1</b>
1.1 Introduction.....	1-1
1.2 Audience.....	1-1
1.3 Documentation Accessibility.....	1-1
1.4 Organization .....	1-1
1.5 Glossary of Icons.....	1-2
1.6 Related Documents .....	1-2
<b>2. Messaging System - An Overview .....</b>	<b>2-1</b>
2.1 Introduction.....	2-1
2.2 Features Provided for Processing Outgoing Messages .....	2-1
2.3 Features Provided for Processing of Incoming Messages .....	2-2
2.4 Archival and Retrieval of Information .....	2-2
2.5 Set- up Messaging Preferences .....	2-2
2.6 Message Notification Process .....	2-2
2.6.1 <i>Outgoing EMS Process</i> .....	2-3
2.6.2 <i>Incoming EMS Process</i> .....	2-5
<b>3. Maintaining Messaging Branch Preferences .....</b>	<b>3-1</b>
3.1 Introduction.....	3-1
3.2 Capturing Messaging Branch Parameters Maintenance screen .....	3-1
3.3 Features of Messaging Branch Preferences screen .....	3-2
3.4 Determining Message Queues .....	3-5
3.4.1 <i>Maintaining Queues</i> .....	3-6
3.5 Maintaining Message Types .....	3-7
3.5.1 <i>Querying for SWIFT Message Tag Description</i> .....	3-9
3.5.2 <i>Viewing SWIFT Message Tags</i> .....	3-10
3.5.3 <i>Maintaining Message Type for Account Opening</i> .....	3-11
3.5.4 <i>Maintaining RTGS Messages</i> .....	3-12
3.6 Maintaining NEFT Messages .....	3-16
3.7 Performing PDE Validations on SWIFT Messages .....	3-19
3.7.1 <i>Processing PDE Messages</i> .....	3-21
3.8 Maintaining Agreements with Sender/Receiver BIC.....	3-22
3.8.1 <i>Transaction Currency Limit Details</i> .....	3-24
<b>4. Maintaining Media Types .....</b>	<b>4-1</b>
4.1 Introduction.....	4-1
4.2 Maintaining Message Media Details.....	4-1
4.3 Features of the Media Maintenance screen .....	4-2
4.4 Maintaining Message Locations .....	4-4
4.5 Maintaining SWIFT Characters .....	4-5
4.6 Maintaining Email Overrides.....	4-6
<b>5. Maintaining Media Control Systems .....</b>	<b>5-1</b>
5.1 Introduction.....	5-1
5.2 Maintaining Message Media Control .....	5-1
5.3 Features on MCS Detailed Screen.....	5-2
5.3.1 <i>SWIFT Server on UNIX</i> .....	5-4

5.3.2	<i>Specifying File Prefix</i> .....	5-4
5.3.3	<i>Saving Details you have Maintained</i> .....	5-4
<b>6.</b>	<b>Maintaining Addresses for Customer</b> .....	<b>6-1</b>
6.1	Introduction .....	6-1
6.2	Customer Account Address Maintenance Screen .....	6-1
6.2.1	<i>Maintaining Additional Scripts</i> .....	6-7
6.2.2	<i>Saving Record</i> .....	6-8
6.2.3	<i>Address Maintenance at Customer (CIF) Level</i> .....	6-8
6.2.4	<i>Maintaining Additional Scripts</i> .....	6-16
6.2.5	<i>Viewing Customer Address</i> .....	6-17
<b>7.</b>	<b>Maintaining Advice Formats</b> .....	<b>7-1</b>
7.1	Introduction .....	7-1
7.2	Advice Format Maintenance Screen .....	7-1
7.2.1	<i>Indicating Messages that should Use Format</i> .....	7-3
7.3	Automatic Printing of Advices Generated during EOD Processing .....	7-4
7.3.1	<i>Starting the Background Process</i> .....	7-4
7.3.2	<i>Printing of Advices</i> .....	7-5
<b>8.</b>	<b>Processing Outgoing Messages</b> .....	<b>8-1</b>
8.1	Introduction .....	8-1
8.2	Manual Generation of Outgoing Messages .....	8-2
8.2.1	<i>Performing Operations on an Outgoing Message</i> .....	8-5
8.2.2	<i>Maintaining BIP Advice File Format</i> .....	8-8
8.2.3	<i>Processing Outgoing Messages with PDE Trailer</i> .....	8-9
<b>9.</b>	<b>Retrieving an Archived Message</b> .....	<b>9-1</b>
9.1	Introduction .....	9-1
9.2	Invoking Message History Retrieval Summary Screen .....	9-1
<b>10.</b>	<b>Processing Incoming Messages</b> .....	<b>10-1</b>
10.1	Introduction .....	10-1
10.2	Viewing Incoming Messages .....	10-1
10.2.1	<i>Background Processing of Incoming Messages</i> .....	10-1
10.2.2	<i>Manual Processing of Incoming Messages</i> .....	10-1
10.2.3	<i>Features on Incoming Message Browser</i> .....	10-2
10.2.4	<i>Linking Guarantee Issuance Contract to an Incoming Message</i> .....	10-5
10.2.5	<i>Operations that you can perform on an Incoming Message</i> .....	10-6
10.2.6	<i>Viewing Details of Incoming Message</i> .....	10-9
10.2.7	<i>Editing Incoming Message</i> .....	10-10
10.3	Viewing SWIFT Notification Messages .....	10-11
10.4	Maintaining MT Task Details .....	10-13
<b>11.</b>	<b>Defining Free Format Messages</b> .....	<b>11-1</b>
11.1	Introduction .....	11-1
11.2	Invoking Free Format Message Maintenance Screen .....	11-1
11.3	Features of Free Format Message Screen .....	11-1
11.3.1	<i>Entering Details of a Free Format Message</i> .....	11-3
11.3.2	<i>Entering an Advice Format using Format Editor</i> .....	11-4
11.3.3	<i>Importing Advice Format from an ASCII File on the Server</i> .....	11-5
11.3.4	<i>Importing Advice Format from ASCII File on Client</i> .....	11-5
11.3.5	<i>Sending Free Format Message</i> .....	11-5
11.3.6	<i>Saving Record</i> .....	11-5
11.3.7	<i>Viewing SWIFT Messages</i> .....	11-6

11.4	Maintaining Common Group Messages .....	11-6
11.5	Maintaining SWIFT FFT Template .....	11-9
<b>12.</b>	<b>Making Query .....</b>	<b>12-1</b>
12.1	Introduction.....	12-1
12.2	Procedure .....	12-1
12.3	Making Query based on more than one criterion .....	12-2
12.4	Selecting Same Criterion to Apply One or More Conditions.....	12-2
12.5	Ordering Details of Query.....	12-4
12.6	Using Wildcards to make Query .....	12-4
<b>13.</b>	<b>Processing SWIFT Messages .....</b>	<b>13-1</b>
13.1	Introduction.....	13-1
13.2	Customer Payments and Cheques.....	13-1
13.2.1	<i>MT 103 Single Customer Credit Transfer</i> .....	13-3
13.2.2	<i>MT 103+ Single Customer Credit Transfer</i> .....	13-5
13.2.3	<i>MT 110 Advice of Cheque(s)</i> .....	13-7
13.2.4	<i>MT 111 Request for Stop Payment of a Cheque</i> .....	13-7
13.2.5	<i>MT 191 Request for Payment of Charges, Interest, and Other Expenses</i>	13-8
13.3	Financial Institution Transfers.....	13-8
13.3.1	<i>MT 200 Financial Institution Transfer for its Own Account</i> .....	13-8
13.3.2	<i>MT 202 General Financial Institution Transfer</i> .....	13-9
13.3.3	<i>MT 203 Multiple General Financial Institution Transfer</i> .....	13-10
13.3.4	<i>MT 204 Financial Markets Direct Debit Message</i> .....	13-11
13.3.5	<i>MT 205 Financial Institution Transfer Execution</i> .....	13-12
13.3.6	<i>MT 210 Notice to Receive</i> .....	13-13
13.4	Treasury Markets - Foreign Exchange, Money Markets and Derivatives.....	13-14
13.4.1	<i>MT 300 Foreign Exchange Confirmation</i> .....	13-14
13.4.2	<i>MT 305 Foreign Currency Option Confirmations</i> .....	13-17
13.4.3	<i>MT 306 Foreign Currency Option Confirmation</i> .....	13-18
13.4.4	<i>MT 320 Fixed Loan/Deposit Confirmation</i> .....	13-25
13.4.5	<i>MT 330 Call/Notice Loan/Deposit Confirmation</i> .....	13-29
13.4.6	<i>MT 340 Forward Rate Agreement Confirmation</i> .....	13-32
13.4.7	<i>MT 341 Forward Rate Agreement Settlement Confirmation</i> .....	13-35
13.4.8	<i>MT 350 Advice of Loan/Deposit Interest Payment</i> .....	13-37
13.4.9	<i>MT 360 Single Currency Interest Rate Derivative Confirmation</i> .....	13-39
13.4.10	<i>MT 361 Cross Currency Interest Rate Swap Confirmation</i> .....	13-49
13.4.11	<i>MT 362 Interest Rate Reset/Advice of Payment</i> .....	13-60
13.4.12	<i>MT 364 Single Currency Interest Rate Derivative Termination/Recouping Con-</i> <i>firmation</i>	13-63
13.4.13	<i>MT 365 Cross Currency Interest Rate Swap Termination/Recouping Confirma-</i> <i>tion</i>	13-67
13.5	Collections and Cash Letters.....	13-71
13.5.1	<i>MT 400 Advice of Payment</i> .....	13-71
13.5.2	<i>MT 410 Acknowledgement</i> .....	13-71
13.5.3	<i>MT 412 Advice of Acceptance</i> .....	13-72
13.5.4	<i>MT 416 Advice of Non-Payment/Non-Acceptance</i> .....	13-72
13.5.5	<i>MT 420 Tracer</i> .....	13-73
13.5.6	<i>MT 422 Advice of Fate and Request for Instructions</i> .....	13-74
13.5.7	<i>MT 430 Amendment of Instructions</i> .....	13-74
13.6	Securities Markets.....	13-75
13.6.1	<i>MT 517 Trade Confirmation Affirmation</i> .....	13-75

13.6.2	<i>MT 518 Market-Side Securities Trade Confirmation</i>	13-76
13.6.3	<i>MT 540 Receive Free</i>	13-82
13.6.4	<i>MT 541 Receive Against Payment</i>	13-85
13.6.5	<i>MT 542 Deliver Free</i>	13-89
13.6.6	<i>MT 543 Deliver Against Payment</i>	13-93
13.6.7	<i>MT 592 Request for Cancellation</i>	13-96
13.6.8	<i>MT 598 Proprietary Message</i>	13-96
13.7	Treasury Markets - Metals	13-97
13.7.1	<i>MT 643 Notice of Drawdown/Renewal</i>	13-97
13.7.2	<i>MT 644 Advice of Rate and Amount Fixing</i>	13-99
13.7.3	<i>MT 645 Notice of Fee Due</i>	13-100
13.7.4	<i>MT 646 Payment of Principal and/or of Interest</i>	13-102
13.7.5	<i>MT 649 General Syndicated Facility Message</i>	13-103
13.8	Documentary Credits and Guarantees	13-104
13.8.1	<i>MT 700 Issue of a Documentary Credit</i>	13-104
13.8.2	<i>MT 701 Issue of a Documentary Credit</i>	13-107
13.8.3	<i>MT 705 Pre-Advice of a Documentary Credit</i>	13-107
13.8.4	<i>MT 707 Amendment to a Documentary Credit</i>	13-109
13.8.5	<i>MT 710 Advice of a Third Bank's or a Non-Bank's Documentary Credit</i>	13-111
13.8.6	<i>MT 720 Transfer of a Documentary Credit</i>	13-113
13.8.7	<i>MT 730 Acknowledgement</i>	13-115
13.8.8	<i>MT 732 Advice of Discharge</i>	13-116
13.8.9	<i>MT 734 Advice of Refusal</i>	13-116
13.8.10	<i>MT 740 Authorization to Reimburse</i>	13-117
13.8.11	<i>MT 742 Reimbursement Claim</i>	13-118
13.8.12	<i>MT 747 Amendment to an Authorization to Reimburse</i>	13-119
13.8.13	<i>MT 750 Advice of Discrepancy</i>	13-120
13.8.14	<i>MT 752 Authorization to Pay, Accept or Negotiate</i>	13-121
13.8.15	<i>MT 754 Advice of Payment/Acceptance/Negotiation</i>	13-122
13.8.16	<i>MT 756 Advice of Reimbursement or Payment</i>	13-123
13.8.17	<i>MT 760 (Guarantee / Standby Letter Of Credit)</i>	13-124
13.8.18	<i>MT 767 Guarantee / Standby Letter of Credit Amendment</i>	13-125
13.8.19	<i>MT 768 Acknowledgement of a Guarantee / Standby Message</i>	13-125
13.9	Cash Management and Customer Status	13-126
13.9.1	<i>MT 900 Confirmation of Debit</i>	13-126
13.9.2	<i>MT 910 Confirmation of Credit</i>	13-126
13.9.3	<i>MT 920 Request Message</i>	13-127
13.9.4	<i>MT 940 Customer Statement Message</i>	13-127
13.9.5	<i>MT 950 Statement Message</i>	13-128
<b>14.</b>	<b>Reports</b>	<b>14-1</b>
14.1	Introduction	14-1
14.2	SMS Log Report	14-1
14.2.1	<i>Contents of Report</i>	14-2
14.3	Unsuccessful Messages Report	14-2
14.3.1	<i>Contents of Report</i>	14-3
14.4	Successful Messages Report	14-3
14.4.1	<i>Contents of Report</i>	14-3
14.5	Daily Swift Message Status Report	14-4
14.5.1	<i>Contents of the Report</i>	14-5
14.6	Statement Message Status Report	14-5

14.6.1 *Contents of the Report* ..... 14-6

**15. **Function ID Glossary**** ..... **15-1**

---

# 1. Preface

## 1.1 Introduction

This manual is designed to help acquaint you with the Messaging System module of Oracle FLEXCUBE.

The module supports various types of media. Besides standard media modes like Mail, Telex and SWIFT you can also use other media types supported by the Media Control System (MCS) installed at the node at which the database of your branch is installed. Oracle FLEXCUBE gives native support for media like Mail, Telex, and SWIFT using EMS as the MCS.

In addition to this User Manual, you can find answers to specific features and procedures, in the Online Help. It can be invoked by choosing Help Contents from the Help Menu of the software. You can further obtain information about to a particular field by placing the cursor on the relevant field and striking the <F1> key on the keyboard.

## 1.2 Audience

This manual is intended for the following User/User Roles:

Role	Function
Back office data entry clerk	Input functions for contracts
Back office managers/officers	Authorization functions
Product Managers	Product definition and authorization
End of Day operators	Processing during End of Day/Beginning of Day
Financial Controller/Product Managers	Generation of reports

## 1.3 Documentation Accessibility

For information about Oracle's commitment to accessibility, visit the Oracle Accessibility Program website at <http://www.oracle.com/pls/topic/lookup?ctx=acc&id=docacc>.

## 1.4 Organization

This manual is organized into the following chapters:





<b>Chapter 1</b>	<i>About this Manual</i> gives information on the intended audience. It also lists the various chapters covered in this User Manual.
<b>Chapter 2</b>	<i>Messaging System - An Overview</i> is a snapshot of the features that the module provides.
<b>Chapter 3</b>	<i>Maintaining Messaging Branch Preferences</i> specifies the messaging branch preferences.



<b>Chapter 4</b>	<i>Maintaining Media Types</i> discusses the procedure to maintain details of the media through which messages can be transmitted from and to your bank.
<b>Chapter 5</b>	<i>Maintaining Media Control Systems</i> discusses details pertaining to Media Control Systems.
<b>Chapter 6</b>	<i>Maintaining Addresses for a Customer</i> discusses the procedure for maintaining addresses for the customers.
<b>Chapter 7</b>	<i>Maintaining Advice Formats</i> explains the procedure for maintaining advice formats.
<b>Chapter 8</b>	<i>Processing Outgoing Messages</i> explains the procedure involved in generating an outgoing message.
<b>Chapter 9</b>	<i>Retrieving an Archived Message</i> deals with the process of retrieving archived messages.
<b>Chapter 10</b>	<i>Processing Incoming Messages</i> explains processing all incoming messages.
<b>Chapter 11</b>	<i>Defining Free Format Messages</i> explains process of defining free format messages.
<b>Chapter 12</b>	<i>Making Query</i> explains the query process.
<b>Chapter 13</b>	<i>Processing SWIFT Messages</i> explains about the SWIFT messages and the categories supported in Oracle FLEXCUBE.
<b>Chapter 14</b>	<i>Reports</i> provides a list of reports that can be generated in this module.
<b>Chapter 15</b>	<i>Function ID Glossary</i> has alphabetical listing of Function/Screen ID's used in the module with page references for quick navigation.

## 1.5 Glossary of Icons

This User Manual may refer to all or some of the following icons:

<b>Icons</b>	<b>Function</b>
	Exit
	Add row
	Delete row
	Option List

## 1.6 Related Documents

You may need to refer to any or all of the User Manuals while working on the Messaging module:

- Core Services

- Core Entities
- Procedures
- Settlements
- Interest

---

## 2. Messaging System - An Overview

### 2.1 Introduction

The Messaging module of Oracle FLEXCUBE is designed to handle your outgoing and incoming messages. The module supports various types of media. Besides standard media modes like Mail, Telex and SWIFT you can also use other media types supported by the Media Control System (MCS) installed at the node at which the database of your branch is installed. Oracle FLEXCUBE gives native support for media like Mail, Telex, and SWIFT using EMS as the MCS.

While defining a product, you can indicate the messages that should be generated for the events that take place during the lifecycle of contracts involving the product. When the events for which a message should be generated occur, the message will be automatically generated and sent to the concerned party. The message will be transmitted to the customer's address through the media that you have specified, and in the format and language that you maintain for the customer – message combination.

While entering the details of a contract you can choose to generate or suppress the message. You also have the option to prioritize the urgency with which a SWIFT message should be generated.

### 2.2 Features Provided for Processing Outgoing Messages

In the case of outgoing messages, the module provides for the generation of messages using formats that you can define. By maintaining message formats you can ensure consistency across the branches of your bank. The module provides a host of features to enter or authorize testwords and to interface with media control systems to actually generate the message.

#### **Several customer addresses for a given media**

With Oracle FLEXCUBE's multi-branch set up, the customers of your bank can operate their accounts from several locations. Based on the convenience of your customers, you can send messages to locations of their choice.

Oracle FLEXCUBE provides for the setting up of several addresses for a given customer - media combination.

In addition, you can also associate a language with an address. All messages sent to the address will be expressed in the language that you indicate.

#### **Free format messages**

In the course of your daily banking operations you may want to generate messages that are not automatically generated by the system or you may have to communicate a message that is very specific to a customer.

In Oracle FLEXCUBE, you can personalize a message by defining a free format message and linking it to a customer - address combination. Whenever the message is to be generated it will bear the personalized format that you have defined.

#### **MCS maintenance**

The messages that are sent from and delivered to your bank are transmitted and received from sources that are external to Oracle FLEXCUBE. In Oracle FLEXCUBE, these external sources are called Media Control Systems (MCS).

In a distributed environment, the database of a branch is located in a node or server. The MCS of the messages are also installed in a node. Thus, while defining an MCS you need to also indicate the node in which it is installed.

## **2.3 Features Provided for Processing of Incoming Messages**

In case of incoming messages, you can set up of various message queues and direct incoming messages to them. You can further grant selective access to the queues to personnel at your bank who are authorized to handle incoming messages.

## **2.4 Archival and Retrieval of Information**

Archival is the process of storing old messages for future retrieval. While defining messaging preferences for your branch, you can specify the number of days for which an outgoing message should be kept in the Outgoing Message Browser. Messages will be automatically archived after the number of days specified for your branch.

You can retrieve the messages that have been archived at anytime and process them just as you would any other message.

## **2.5 Set- up Messaging Preferences**

You can specify messaging preferences that will govern the workflow aspects of the messaging system module at your branch. You can indicate the following preferences:

- The number of days for which outgoing messages should be kept in the Browser for every branch
- Whether a testword is required for Telex messages
- The activities on a message that require authorization
- The PDE (Possible Duplication Emission) Archival period
- The text for duplication check
- The Hold Mail text to be displayed
- The Swift Key arrangement values
- Whether Authorization is required for the actions like Cancel, Hold, Change Node, Test Word. etc. on a Generated Message.

## **2.6 Message Notification Process**

The Electronic Messaging Process is for both incoming and outgoing messages in Oracle FLEXCUBE.

In Incoming EMS Process, a job is scheduled to poll the incoming folder on timely basis. Once a message is received in the folder, the job picks the message and sends it to an internal JMS queue. An MDB listening on the queue reads the message and identifies the media and processes the message.

In Outgoing EMS Process a job is scheduled to poll the outgoing messages that are generated but not handed off. Each messages polled is sent to an internal JMS queue. An MDB, acting upon the internal JMS queue picks the message from queue and sends the message to appropriate destination (Folder, or e-mail, or JMS queue).

## 2.6.1 Outgoing EMS Process

The Outgoing EMS Process is in two layers. The EMS process as part of jobs in FCJ scheduler, polls the outgoing message table of FLEXCUBE for generated and un-send messages. The job then sends minimal data about the message to be handed off, to an internal JMS queue. The EMS process as part of an MDB that listens on internal JMS queue builds final message and sends to their intended destinations.

The 'EMS out' job is available as factory shipped.

The Outgoing EMS Process as part of jobs scheduler is as follows:

- Once the job is triggered, it polls outgoing messages table for generated and unsend messages.
- Each message is then sent to an internal JMS queue.
- The job is then rescheduled to fire next time.

The Outgoing EMS Process in MDB is as follows:

- An MDB listens on the internal EMS outgoing queue and it builds the final message sent to intended destinations.
- In case of any exception while processing, message is sent to a deferred queue.

The following diagram illustrates outgoing EMS process in scheduler.

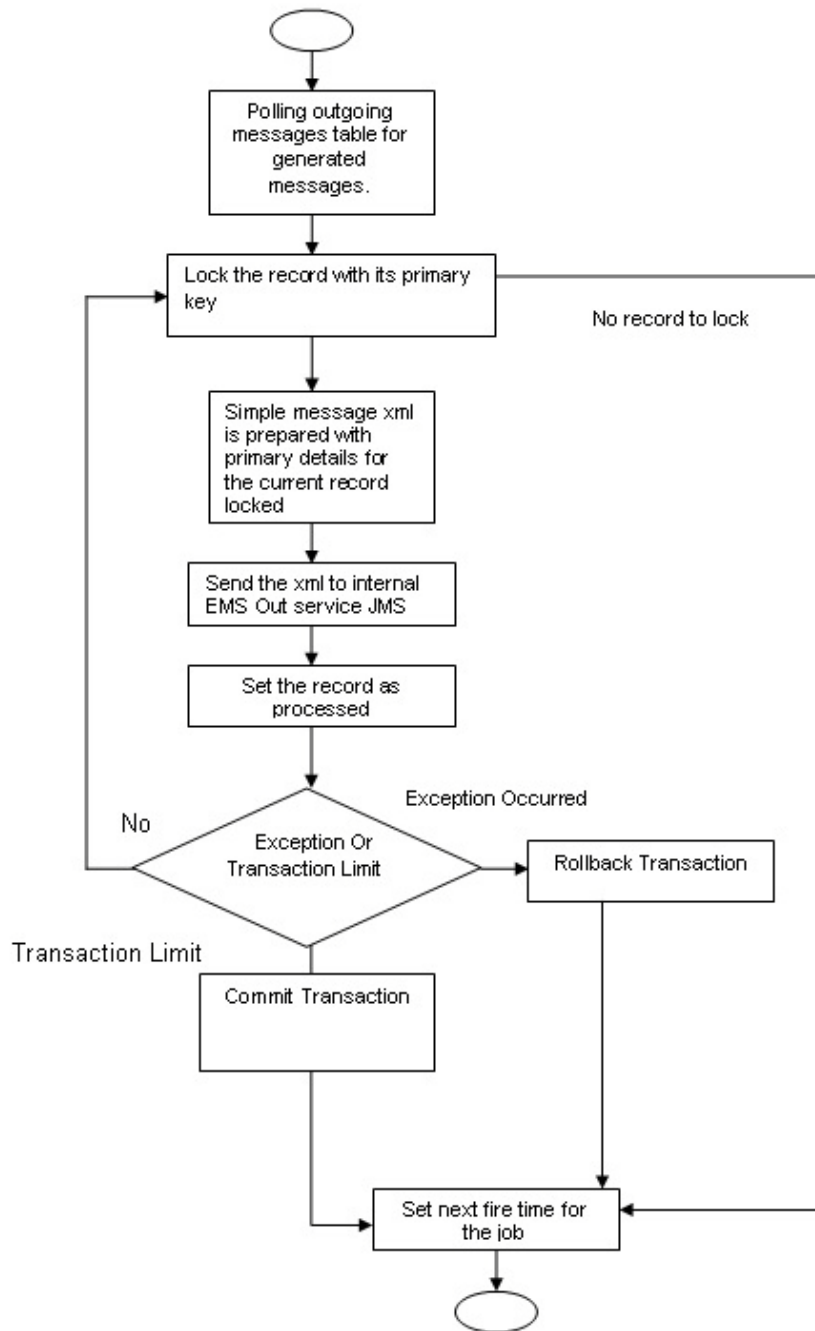

The following diagram illustrates outgoing EMS process in MDB.

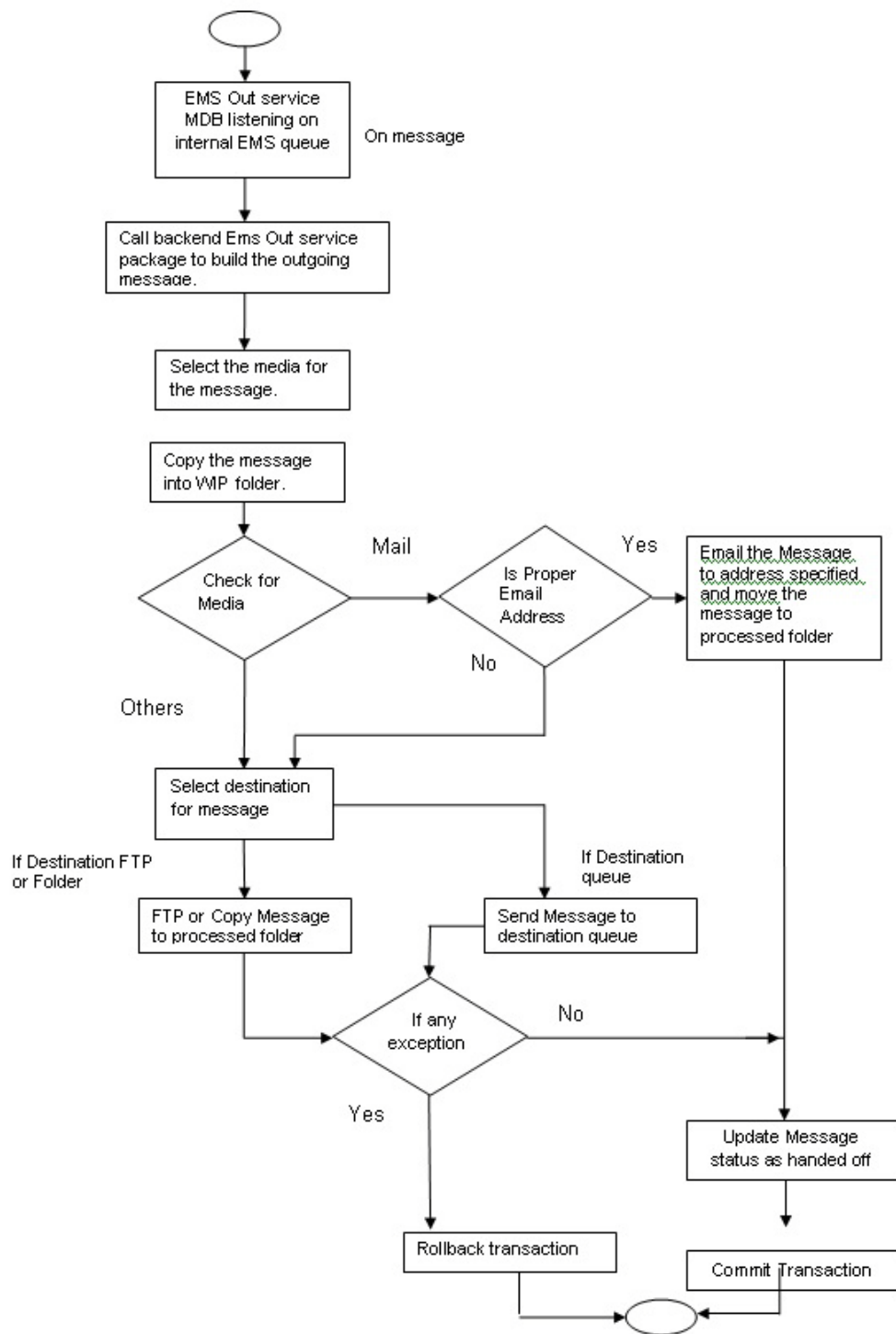

## 2.6.2 Incoming EMS Process

The Incoming EMS Process is in two layers. The EMS process as part of jobs in FCJ scheduler, polls the pre configured folder for messages and sends the messages read, to EMS internal queue. The EMS process as part of an MDB listening on internal JMS queue, identifies the message from queue and calls the incoming messages service package to process the message.

The 'EMS in' job is available as factory shipped.

The Incoming EMS Process as part of jobs scheduler is as follows:

- Once the job is triggered, it polls for messages in a folder (Configured for incoming messages).
- Each message is then sent to an internal JMS queue.
- The job is then rescheduled to fire next time.

The Incoming EMS Process in MDB is as follows:

- An MDB that listens on the internal EMS incoming queue receives the message.
- The media details are identified and incoming message processing package is called to process the message.
- In case of any exception while processing, message is sent to a deferred queue.
- In case of messages directly arriving to JMS queue instead of a folder; the same MDB is configured to listen on specific queue.

The following diagram illustrates incoming EMS process in Job Scheduler..

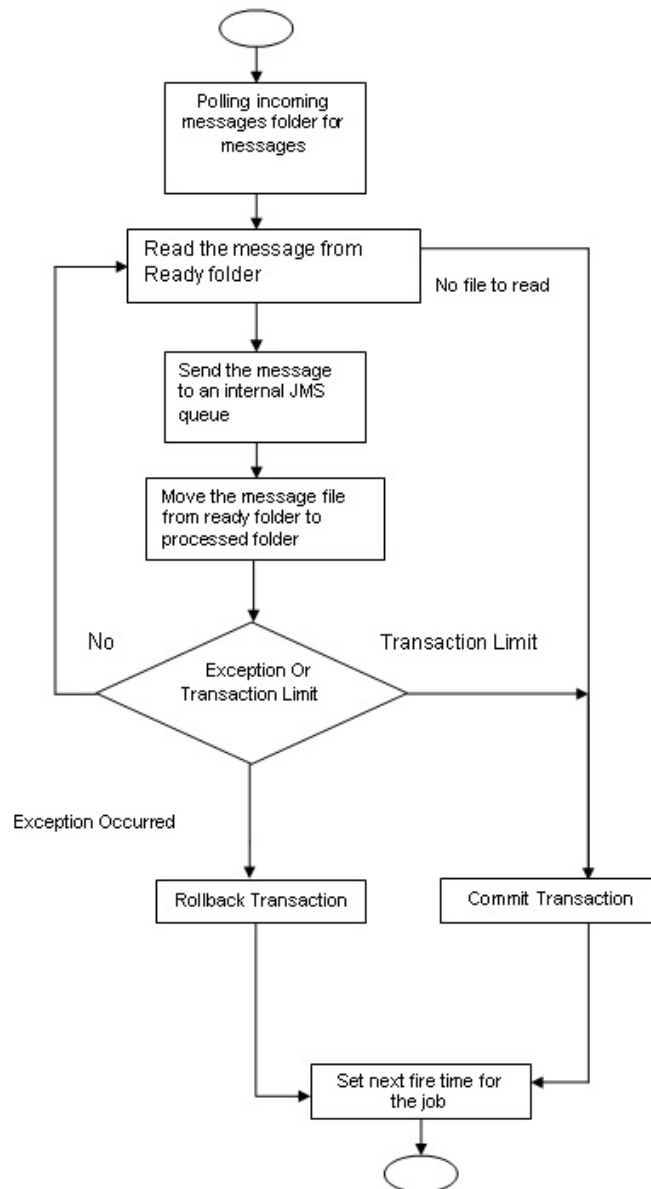



The following diagram illustrates incoming EMS process in MDB.

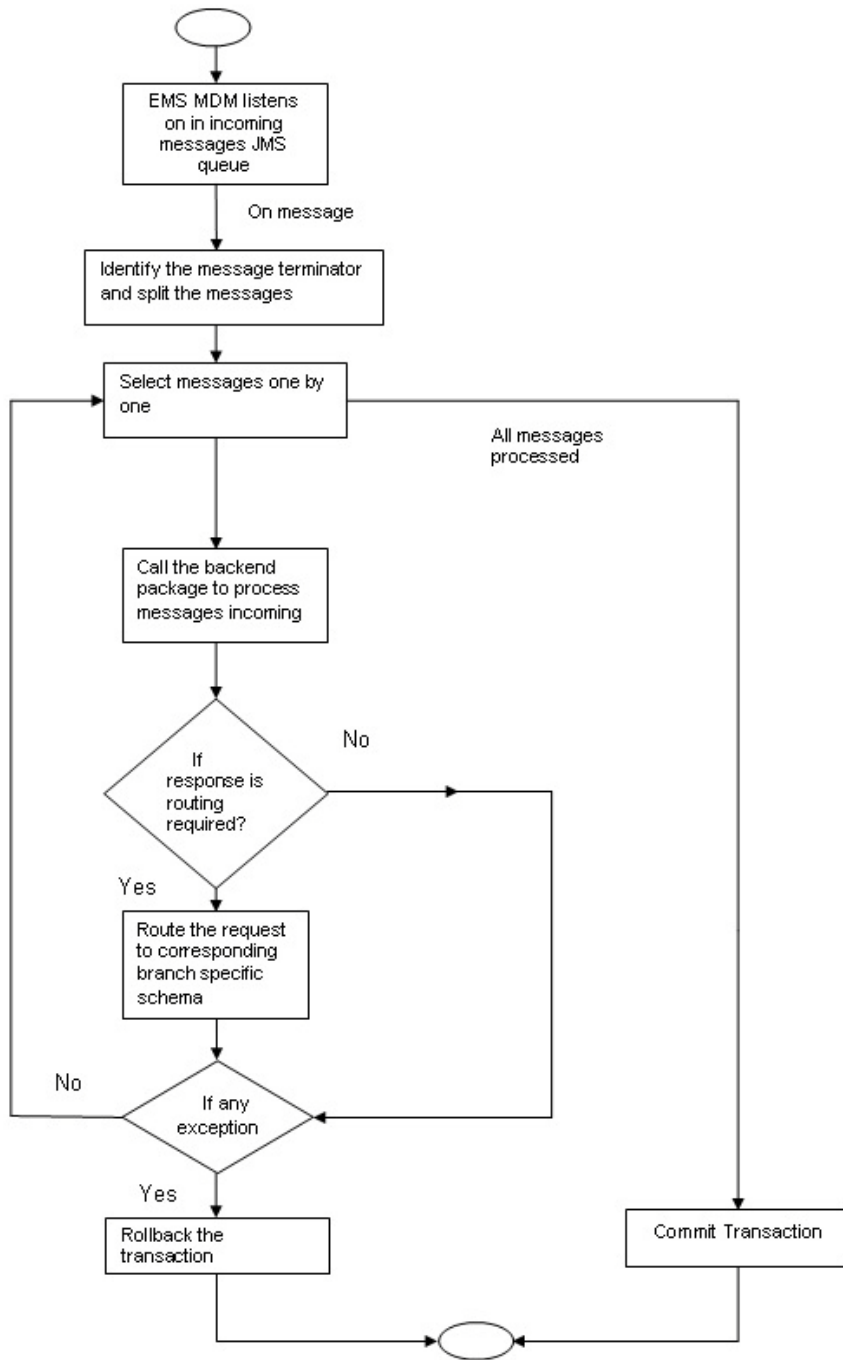

---

## 3. Maintaining Messaging Branch Preferences

### 3.1 Introduction

The messaging preferences that you indicate for your branch will govern the workflow aspects of the messaging system module. You can specify messaging preferences for your branch in the 'Messaging Branch Preferences' screen. In this screen you can indicate:

- The number of days for which outgoing messages should be kept in the browser
- Whether a test word is required for telex messages
- The activities on a message that require authorization
- The PDE Functional Validation / archive period
- The Text for hold mail and duplicate check

---

#### **Note**

You can specify preferences only for the branch from which you logged onto Oracle FL-EXCUBE.

---

### 3.2 Capturing Messaging Branch Parameters Maintenance screen

To invoke the 'Messaging Branch Parameters Maintenance' screen, type 'MSDPREF' in the field at the top right corner of the Application tool bar and click the adjoining arrow button.

If you are maintaining preferences for a new branch of your bank, click the 'New' button on the Application toolbar. The 'Messaging Branch Parameters Maintenance' screen is displayed without any details.

If you are calling a branch preference record that has already been defined, double-click a record of your choice from the summary screen. In the 'Summary' screen, all the branch preference records that you have entered will be displayed in a tabular form.

The screen is shown below:

**Messaging Branch Parameter Maintenance**

New

**Branch Preference**

Branch Code \*

Message Archive Period

PDE Archive Period

Text for Duplicate

Hold Mail Text

Test Word check  Yes  
 No

PDE Functional Validation

SK Arrangement

**Authorization**

Cancel

Hold

Change Node

Test Word

Auth Repair Incoming

Carry Forward

Change Media

Regenerate

Change Address

Reinststate

Release

Branch Move

Test Word Check

Change Priority

**Fields**

Maker  
Checker

Date Time:  
Date Time:

Mod No

Record Status  
Authorization Status

Exit

### 3.3 Features of Messaging Branch Preferences screen

In the 'Messaging Branch Parameters Maintenance' screen you can only maintain (create or modify) the preferences for the current logged in branch. However, you can view the preferences maintained for other branches.

Following are the details captured here:

#### **Branch**

Specify the branch for which you are maintaining the preferences.

#### **Message Archive Period**

Archival is the process of storing old messages for future retrieval. You can specify the number of days for which an outgoing message should be kept in the Outgoing Message Browser.

A message will be automatically archived after the number of days that you specify. You can un-archive the details of outgoing message that has been archived by invoking the 'Message History Retrieval' screen. After you un-archive an outgoing message you can process it just as you would any other outgoing message.

---

#### **Note**

It is recommended that you indicate a value of 'one' in this field. In this case, only those messages that have been triggered for generation today will be displayed in the Outgoing Message Browser.

---

#### **PDE Archive Period**

Specify the number of days for which messages should be kept in the queue for PDE Possible Duplicate Emission) identification. System does not consider messages for PDE identification post the PDE archive period maintained here.

---

**Note**

The PDE archive period should be less than or equal to message archival days.

---

**Text for Duplicate**

Every message is maintained in the Outgoing Browser, as an un-generated copy of the original. When the copy is generated, it will contain, along with the contents of the original message, any additional text that you have maintained in the Text for Duplicate field.

**Hold Mail Text**

All the mail advices generated for a customer for whom 'Add Hold Mail Text' is checked at the Customer Address Maintenance would have the hold mail text maintained in this field. This text will be displayed on top of the message.

**Test Word Check**

You can indicate whether a testword needs to be entered before a telex message is generated from and received at your branch. You can state your preference from the Yes/No option that is available.

**PDE Functional Validation**

Check this box to indicate that system should identify an outgoing message as PDE (Possible Duplicate Emission) using functional key or not.

The PDE validation is done either using the hash value of the SWIFT message or using the tag/field value of the message. If this option is checked, Oracle FLEXCUBE identifies duplicate messages by performing PDE functional validations also. Hash value based validation shall be done irrespective of this option being checked.

**Indicating the activities that require authorization**

You can perform several activities on a message that is to be generated from your branch and on those that have come in for your branch. For example, from the outgoing or incoming browser, you can change the address to which a message should be sent.

In the branch preferences screen, you can indicate the activities which when performed on an incoming or outgoing message, would require subsequent manual authorization for the message. Several activities have been listed in this screen. A message, on which an activity which has been selected in this screen is performed, would require subsequent manual authorization for the activity to take effect. A message, on which an activity not selected in this screen is performed, would be automatically authorized with the activity taking effect.

The activities that you can choose from are:

- Cancel
- Hold
- Change Node
- Testword
- Auth Repair Incoming
- Carry Forward
- Change Media
- Regenerate
- Regenerate
- Change Address
- Reinstate
- Release

- Carried Forward
- Branch Move
- Change Media
- Change Priority
- Testword Check
- Auth Repair Incoming

A message on which you perform an activity that requires authorization will be available for further processing only after it is authorized.

### **SK Arrangement**

You can choose the action to be performed on the message based on the Swift Key arrangement with the receiver. The options available for choosing are:

- Validate – If you choose this option, the system validates if a SK arrangement exists between your bank and the receiver. If Yes, then the original SWIFT message is generated otherwise, the message will go to repair.
- Generate FFT- If you choose this option, the system validates if a SK arrangement exists between your bank and the receiver. If Yes, then the original SWIFT message is generated otherwise, MT 999 (Free Format Messages) will be generated instead of the SWIFT message.
- No Validation- If you choose this option, you are instructing the system not to Validate but send the original SWIFT message always.

Processing SWIFT Messages if SK arrangement is 'Validate' in the static messaging table:

- Oracle FLEXCUBE checks for the value in the branch's SK arrangement Field
- If the field value is 'No validate', Oracle FLEXCUBE will generate messages the normal way.
- If the SWIFT keys have been exchanged then the swift message will be generated
- If SWIFT keys have not been exchanged with the receiver and the value of SK arrangement for the branch is 'Validate' then the following messages will go to repair: MT420, MT754 and MT756. For all other messages, the original SWIFT message gets generated whether swift key exists or not.
- If SWIFT keys have not been exchanged with the receiver and the value of SK arrangement for the branch is 'Generate FFT' then the message MT999 would be generated instead of original SWIFT message.

### **Generation of MT999**

- Message header is changed from the original header to MT999
- That portion of the message after tag 21 will be prefixed with tag 79 followed by the original SWIFT message
- The message will be populated with the same contents as the original SWIFT message with the respective SWIFT tags
- The system will generate MT999 even if the SWIFT Key Arrangement does not exist with the receiver. MT999 will be generated for the following SWIFT messages:
  - MT750 – Advice of Discrepancy
  - MT734 – Advice of Refusal
  - MT752 – Authorization to pay, accept or Negotiate

### **Saving the record**

After you have made the mandatory entries, save the record. This record should be authorized before the End of Day process (EOD) is run.

Click 'Exit' or 'Cancel' button to return to the Application Browser.

## 3.4 Determining Message Queues

For a combination of the following, you can specify the branch (queue) to which the message is to be routed:

- **Media** – represents the delivery media. Typically, your entry would be SWIFT.
- **BIC Code** - represents the receiver's BIC for which a message is to be routed to a specific queue in a particular branch. You can choose to specify the wildcard ALL entry in this field.
- **Message Type** - indicates the message type for which routing procedure is required. You can choose to specify the wildcard ALL option as well.
- **Currency** – indicates the currency of the incoming message. For example in an MT103 it would be from tag 32A. This is an additional parameter to determine the booking branch and queue. You can also choose to maintain the wildcard ALL entry.
- **Booking Branch** - indicates the branch in which incoming messages are routed. A set of all the branches having the same SWIFT BIC as that mentioned in the BIC code field is displayed in the option list.

This maintenance can be performed through the 'Message Queue Mapping Maintenance' screen. To invoke this screen, type 'MSDQMAP' in the field at the top right corner of the Application tool bar and click the adjoining arrow button.

The screenshot shows a software window titled "Message Queue Mapping Maintenance". At the top, there are icons for "New" and "Enter Query". The main area contains several input fields with red asterisks indicating required fields: "Media \*", "BIC Code \*", "Currency \*", "Booking Branch \*", "Branch Name", "Message Type \*", and "Queue \*". Below these fields is a section titled "Field Properties" which includes labels for "Maker", "Checker", "Mod No", "Date Time:", "Record Status", and "Authorization Status". An "Exit" button is located in the bottom right corner of the window.

While processing MT700 and MT701 messages the System ensures the following:

- MT700 and MT701 are routed to the branch using the Incoming Routing specifications maintained in this screen
- For MT700, in case the branch of the corresponding MT701 is different from that of the MT700 it is re-aligned to the branch of the MT700
- MT701 messages are processed only after the receipt of MT 700

---

**Note**

You can maintain the same BIC for the main branch as well as the sub-branch.

---

### 3.4.1 **Maintaining Queues**

All Incoming SWIFT and Non Swift Messages are routed through a messaging queue. You need to maintain different user queues to which incoming messages are directed. Users with appropriate rights are allowed to access a particular queue.

You can invoke the 'Message Queue Maintenance' screen by typing 'MSDQMNT' in the field at the top right corner of the Application tool bar and clicking the adjoining arrow button.

The screenshot displays the 'Message Queue Maintenance' application window. At the top, there is a search bar labeled 'Enter Query'. Below this, the 'Queues' section includes a 'Queue \*' input field, a 'Description' input field, and a 'Collection Queue' checkbox. The 'Swift Messages Queue' section features a grid with a 'Message Code \*' header. The grid shows '1 Of 1' records. At the bottom of the window, there are fields for 'Maker', 'Checker', 'Mod No', 'Date Time', 'Record Status', and 'Authorization Status', along with an 'Exit' button.

In this screen you can capture the following details for a queue:

- A name to identify the queue uniquely throughout the system.
- A short description of the queue
- The codes of various SWIFT and Non SWIFT messages that would be routed to this queue.
- Select collection queue flag if the unique queue you are maintaining here is a collection Queue.

---

**Note**

The codes of various SWIFT and Non SWIFT messages list in the grid is not applicable for the collection queue.

---

You can assign a message to more than one messaging queue. At the time of maintaining rules for a message (discussed in the subsequent sections of this document), you can select the appropriate queue for each rule from the list of queues to which the message is linked.

Select 'Add' from the Actions menu in the Application tool bar or click add icon to add a message to the queue being defined. To remove a message from the queue, Select 'Delete' from the Actions menu in the Application tool bar or click delete icon.

Refer to CN Module for more details on Collection Queue.

## 3.5 Maintaining Message Types

You can maintain message types in Oracle FLEXCUBE through the 'Message Type Maintenance' screen. To invoke 'Message Type Maintenance' screen, type 'MSDMSTYM' in the field at the top right corner of the Application tool bar and click the adjoining arrow button.

The screenshot shows the 'Message Type Maintenance' window. It includes a 'Save' button at the top left. The main form area contains the following fields and controls:

- Module \* (dropdown menu)
- Message Type \* (text field)
- Description \* (text field with a refresh icon)
- Priority \* (dropdown menu, currently set to 'Normal')
- Maximum Message Count (text field)
- Purge Message (dropdown menu)
- Acknowledgment Nak Processing (dropdown menu)
- Swift Messages section (For Product Setup):
  - SWIFT Message Type (text field)
  - Consolidated Message Type (text field)
  - Generate at input (checkbox, unchecked)
  - Show In Product (checkbox, checked)
- Fields section (bottom):
  - Maker
  - Checker
  - Mod No
  - Date Time:
  - Record Status
  - Authorization Status
- Cancel button (bottom right)

You will need to capture the following information in this screen:

### **Module**

Specify the module for which you are maintaining message types. The adjoining option list displays all module codes available in Oracle FLEXCUBE. You can select the appropriate one.

### **Message Type**

Specify the message type for which SWIFT codes can be maintained.

### **Description**

Enter a brief description of the message type.

### **Priority**

Specify the priority in which a message is to be sent is displayed. You have the option to change the priority. To change the priority specified for a message, click the button marked 'Change Priority'. Thereafter, select an option from the option-list that is available for this field.

### **SWIFT Message Type**

Indicate the SWIFT message type in which the free format message should expressed. For the following message types in BC module, you need to indicate the SWIFT message type as MT999:



- DISCREPANCY\_REQ
- ACCEPT\_REFUSAL
- DISCREPANCY\_AUT

---

**Note**

NEFT and RTGS message types will be factory shipped which are available as Swift message type. These messages will be available only for PC module.

---

Following are the NEFT and RTGS message types generated:

Message Type	Description	NEFT / RTGS Message Type
CUST_PYMT_RIND	RTGS Customer Payment Request	R41
BANK_PYMT_RIND	RTGS Interbank Payment Request	R42
DR_NOTIFICATION	RTGS debit notification	R43
CR_NOTIFICATION	RTGS credit notification	R44
STLMNT_NFTN_RBI	RTGS sender settlement notification	R09
STLMNT_NFTN_PI	RTGS PI Response	R90
CUST_PYMT_NIND	NEFT – Incoming Payment Message	N02
RETURN_TRN_RBI	NEFT - Message for transmitting return transaction details	N03
DR_MSGS_NIND	Outward Debit Messages from NEFT Branches	N06
RETURN_TRN_N-BRN	Return Transaction from NEFT Branches	N07
REJECT_TRN_NIND	NEFT - Transmission of Rejected Transactions at NEFT Service Station to Bank Branches	N09
CREDIT_ACK	Credit Acknowledgement Message for N02 and N06	N10
ACK_MSG_SFMS	Acknowledgement message from SFMS	F20
NEG_ACK_MSG	Negative acknowledge message from SFMS	F25
NEG_ACK_SUSR	Negative acknowledge message from SFMS User	F26
ACK_MSG_BKAPI	Acknowledgement message from Bank API	F27

**Generate at input**

Check this box to indicate that this message is to be generated at the time of input of the contract, and not after authorization.

### Show in product

Check this box to indicate that this message will be available in the product to be maintained against a particular event.

## 3.5.1 Querying for SWIFT Message Tag Description

You can query for tag descriptions for SWIFT messages using the screen 'Swift Tag Maintenance' screen. You can invoke the screen by typing 'MSDMSGTM' in the field at the top right corner of the Application tool bar and click the adjoining arrow button.

The screen is as shown below:

Tag Name	Description	Tag Option	Lines	Sequence	Repeatable
					<input type="checkbox"/>

Specify the following fields:

### Swift Tag Maintenance

#### Swift Message Type

Specify the swift message type. The adjoining list displays a list of message types maintained in the system. Choose the appropriate one.

#### Description

The system displays the message description.

### Tag Description

#### Tag Name

The system displays the tag name.

#### Description

The system displays the description.

#### Tag Option

#### Lines

The system displays the number of lines required for the tag.

**Sequence**

The system displays the tag sequence number.

**Repeatable**

Indicates whether the tag is repeatable or not.

**All Options**

Indicates all options.

**Sequence Name**

Specify the sequence number.

**Note**

Swift message tag descriptions are factory shipped. However, it can also be maintained using this screen.

**3.5.2 Viewing SWIFT Message Tags**

You can view the SWIFT messages and tag descriptions using the 'Message Preview Browser' screen. You can invoke this screen by typing 'MSDMSPRV' in the field at the top right corner of the Application tool bar and click the adjoining arrow button.

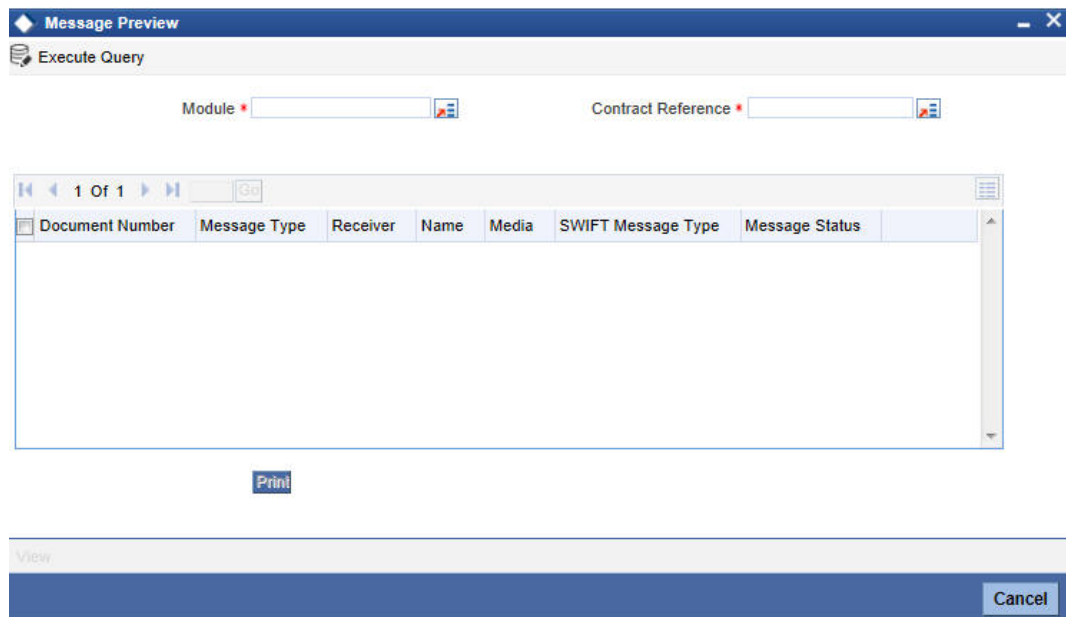

You can search for the messages based on the following parameters:

**Module**

Specify the module. The adjoining list displays a list of module names maintained in the system. Choose the appropriate one. This is applicable only for the following modules:

- LC
- BC
- MS
- LI
- IB

### Contract Reference

Specify the contract reference number. The adjoining list displays a list of reference numbers maintained in the system. Choose the appropriate one.

Once you have set the search parameters, click 'Execute Query' button. The system displays the messages that satisfy the search criteria.

#### 3.5.2.1 Viewing Message/Advice

Select a message/ advice and click 'View' button to view the complete message/advice. The system will display the following details in a new window..

The screenshot shows a window titled 'Message' with a search bar and several input fields. The search criteria are: Reference Number: 000FTBB110040002, Receiver/Sender: 000003171, DCN: 000MSOG1100405QW, Message Type: DEBIT\_ADVICE, and SWIFT Message Type. Below the search fields, there is a 'Message' section with a 'NON-OPERATIVE COPY' warning. The message content is: DEBIT ADVICE, DATE: 04-JAN-11, PAGE: 1, OATS\_AUTO\_KYC\_R, Phoenix House Rushton Avenue, BD3 7BH, Thornbury Bradford, PAGE: 1, CUSTOMER ID: 000003171, ACCOUNT: 000003171225, ACCOUNT DESCRIPTION: 000003171225. At the bottom, there are fields for 'Remarks', 'Reject Reason', and 'Message Trailers', and an 'Exit' button.

You can view the following details:

- Reference number of the message/advice
- Document number generated for the message/advice
- Version number of the message/advice
- Receiver/sender of the message
- Type of the message
- Type of the SWIFT message
- Complete text of the message/advice
- Remarks, if any
- Reject reason, if any
- Message trailer

#### 3.5.2.2 Printing Message/Advices

From the 'Message Preview' screen, you can print a message/advice using the 'Print' button. Select the message/advice and click 'Print' button to print the message.

#### 3.5.3 Maintaining Message Type for Account Opening

You can maintain a specific message type to be associated with account opening event class.

The Events Class Maintenance screen is as shown below:

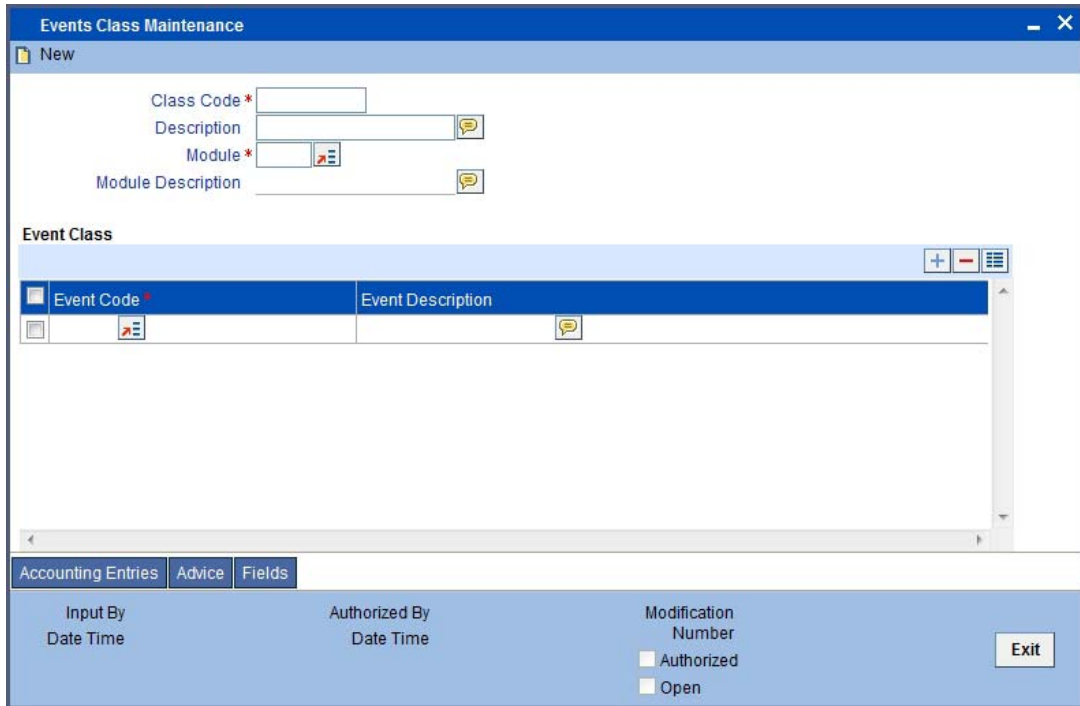

Specify the following details.

**Module**

Specify the module as 'DE'.

**Message Type**

Specify as 'ACC\_OPADV'.

*For further details, refer the section 'Maintaining Message Types' in this User Manual.*

You can specify a format for this message using the "Advice Format Maintenance" screen. Then you can associate this message to the event class maintained for account opening.

*Refer the chapter Maintaining Advice Formats in this User Manual for details about format maintenance.*

**3.5.4 Maintaining RTGS Messages**

The system will support the following RTGS payment messages:

Sr No	Network (from Product)	Message Type (Outgoing /Incoming)	Product Type (from Product Category)	Transfer Type (from Product Category)	Message Name	Message Description
1	RTGS	Outgoing	Outgoing Payment	Customer	R41	This message will be generated for outgoing payment contract to customer using RTGS product.

2	RTGS	Incoming	Incoming Payment	Customer	R41	This is a Incoming RTGS Payment to customer
3	RTGS	Outgoing	Outgoing Payment	Bank	R42	This message will be generated for outgoing payment contract to bank using RTGS product.
4	RTGS	Incoming	Incoming Payment	Bank	R42	This is a Incoming RTGS Payment to Bank
5	RTGS	Incoming	Reject of Outgoing Payment	Customer	R42	This Message is for a return of our Outgoing Payment- If the tag 7495 contains / RETURN/ and outgoing payment reference number contains (eg: :7495:/ RETURN/ / 012COPB112730 001) then it is a Reject of Outgoing Payment otherwise it is a Incoming Payment and product can be resolved based on the network and Transfer type as Customer

6	RTGS	Incoming	Reject of Outgoing Payment	Bank	R42	This Message is for a return of our Outgoing Payment- If the tag 7495 contains / RETURN/ and outgoing payment reference number contains (eg: :7495:/ RETURN/ / 012COPB112730 001) then it is a Reject of Outgoing Payment otherwise it is a Incoming Payment and product can be resolved based on the network and Transfer type as Bank
7	RTGS	Outgoing	Reject of Incoming Payment	Bank	R42	This message and transaction will be generated when authorizer rejects the incoming payment of bank
8	RTGS	Incoming	Incoming Payment	Bank	R44	Credit Notification. Refer the Debit/ Credit Notification section for detail of this message
9	RTGS	Incoming	Outgoing Payment	Bank	R43	Debit Notification. Refer the Debit/ Credit Notification section for detail of this message

10	RTGS	Incoming	Workflow		R09	This is a return message for our outgoing payment received from the RBI. This is only the Ack/NACK message for outgoing payments. If it is Ack message then system will update message status as Fully Completed (PD). If it is NACK message then system will reverse the corresponding outgoing payment contract and the message status will be updated as Process Reversed (PR)
11	RTGS	Incoming	Workflow		R90	This is a return message for our outgoing payment received from the PI (Participant Interface). This is only the Ack/NACK message for outgoing payments. If it is Ack message then system will update message status as Partially Completed (HD). If it is NACK message then system will reverse the corresponding outgoing payment contract and the message status will be updated as Process Reversed (PR)

**RTGS Debit and Credit Notifications**

Debit Notifications are incoming messages from RBI generated to indicate that a debit has been applied to a participants settlement account by the transaction initiated by RBI. The



message format is R43. This notification will consist of debits in the settlement account initiated by RBI only.

Credit Notifications are incoming messages from RBI generated to indicate that a credit has been applied to a participants settlement account by the transaction initiated by RBI. The message format is R44. This notification will consist of credits in the settlement account initiated by RBI only.

### 3.6 Maintaining NEFT Messages

The system will support the following NEFT payment messages:

Sr. No	Network (from Product)	Message Type (Outgoing/Incoming)	Product Type (from Product Category)	Transfer Type (from Product Category)	Message Name	Message Description
1	NEFT	Outgoing	Outgoing Payment	Customer	N06	This message will be generated for outgoing payment contract to customer using NEFT product.
2	NEFT	Outgoing	Reject of Incoming Payment	Customer	N07	This message will be generated for the return of incoming payment. This message will be generated when authorizer rejects the incoming payment from the incoming authorization queue or repair queue. The product category for this return of incoming payment transaction will be picked up from the product category of incoming payment
3	NEFT	Incoming	Incoming Payment	Customer	N02	This is a Incoming NEFT Payment
4	NEFT	Incoming	Reject of Outgoing Payment	Customer	N02	This Message is for a return of our Outgoing Payment- Check the Related Reference Number tag in the message. If the field is there then it is a Return of Outgoing Payment

5	NEFT	Incoming	Reject of Outgoing Payment		N03	<p>This Message is from RBI for a return of our Outgoing Payment- There are two Possibilities of this Message - it can be a Reject of the Outgoing Payment or a Reschedule Message - to Find out whether it is a Reject message - Check the Related Reference Number and Reject Codes - if the Reject code doesn't fall into the Reschedule list then it is a reject of Outgoing Payment - otherwise Reschedule Message and the message status will be updated as Rescheduled(RS)</p>
6	NEFT	Incoming	Work-flow(Reschedule)		N03	<p>This Message is from RBI for a reschedule of our Outgoing Payment-</p> <p>The reject code type of this message will be 'Reschedule' - If it is a Reschedule message then system will update only the message status of the contract as Rescheduled (RS). This reschedule message normally will be coming in during the day. Our scheduler will pick up this message and resend it to network for next schedule</p>

7	NEFT	Incoming	Reject of Outgoing Payment	Customer	N09	This Message is from SFMS for a return of our Outgoing Payment- There are two Possibilities of this Message - it can be a Reject of the Outgoing Payment or a Reschedule Message - to Find out whether it is a Reject message - Check the Related Reference Number and Reject Codes - if the Reject code doesn't fall into the Reschedule list then it is a reject of Outgoing Payment and message status will be updated as Processing Failed(XE) - otherwise it will be a Reschedule Message and message status will be updated as Rescheduled(RS).
8	NEFT	Incoming	Workflow (Reschedule)		N09	This Message is from SFMS for a reschedule of our Outgoing Payment-  The reject code type of this message will be 'Reschedule' - If it is a Reschedule message then system will update the message status as Rescheduled(RS) and system will resend the message to the network on next working day
9	NEFT	Incoming	Workflow		F20	This is an acknowledgement message from SFMS. If this message is received then the message status of original contract will be updated as Partially Completed(HD)

10	NEFT	Incoming	Workflow		F25	This is a Negative acknowledge message from SFMS. If this message is received then system will reverse the corresponding outgoing payment contract and the message status will be updated as Processing Reversed(PR)
11	NEFT	Incoming	Workflow		F26	This is a Negative acknowledge message from SFMS User. If this message is received then system will reverse the corresponding outgoing payment contract and the message status will be updated as Processing Reversed(PR)
12	NEFT	Incoming	Workflow		F27	This is a acknowledgement message from Bank API. If this message is Negative Acknowledgement then the corresponding contract will be reversed and the message status will be updated as Processing Reversed (PR). If this message is Positive Acknowledgement then the message status of original contract will be updated as Fully Completed(PD)
11	NEFT	Outward/ Inward Credit Confirmation Message at branch			N10	This is acknowledgment for N02 and N06.

### 3.7 Performing PDE Validations on SWIFT Messages

Oracle FLEXCUBE allows you to tag SWIFT messages (both incoming and outgoing) as duplicate if it identifies that the same message was sent/received earlier. Once the message

is detected as a duplicate message the trailer of the message is appended to reflect this information.

---

**Note**

This is applicable only for MT103 and MT202 messages.

---

For incoming SWIFT messages which have a PDE trailer, system interprets the trailer information and sets aside those messages marking its process status as 'Exception'. However, Oracle FLEXCUBE allows you to either accept or reject the message identified as a PDE, from the Incoming message browser.

For outgoing SWIFT messages, system performs certain PDE validations, to identify duplicate messages. Following are the two types of PDE validations that the system performs:

- Hash Value Based PDE Validation
- Message field (Tags) Based PDE Validation

**Hash Value Based PDE Validation**

System calculates the hash value of a message when the message is generated and stores it in a data store. System then compares this value with the hash values in the message log to identify duplicates.

---

**Note**

System performs hash value validation on messages as a mandatory check.

---

**Message field (Tags) Based PDE Validation**

Tag based PDE validation is performed only for Customer Transfer (MT103) and Bank Transfer (MT202) messages. You can decide the tag value based on which system needs to perform the validation.

---

**Note**

Tag value validation is done only if you have selected the 'PDE Functional Validation' option in the 'Messaging Branch Parameters Maintenance' screen.

---

System uses the following fields to compare and identify whether a message is a PDE or not. This data is factory shipped.

### Customer Transfer MT103

Message Tag	Option	Tag Description
50	A, K, F	Ordering Customer
32	A	Interbank Settlement Amount
32	A	Currency
32	A	Value Date
57	A, B, C, D	Account With Institution
59	A or No letter	Ultimate Beneficiary

### Bank Transfer MT202

Message Tag	Tag Description	Field Position
32	A	Interbank Settlement Amount
32	A	Currency
32	A	Value Date
58	A or D	Beneficiary Institution

---

#### Note

You can also choose not to use any of the above tags for comparison. Along with the above fields the Sender and Receiver BIC are also used for procedural validation.

---

## 3.7.1 Processing PDE Messages

The system detects the messages (Incoming/Outgoing) as PDE messages by performing the validations discussed in the above section. The Incoming and Outgoing PDE messages are processed by the system in the following manner:

### 3.7.1.1 Incoming PDE Messages

In the case of incoming messages, EMS picks up the incoming messages and inserts it into a data store. If the incoming message has a PDE trailer (message contains the text '*PDE:*') then the system will mark the process status as 'Stopped due to PDE'. After due validations, you can release the message from the incoming PDE message queue. Once these messages are accepted it will continue to get uploaded as a normal message. If the PDE trailer is NOT present in the incoming message, then the message upload will continue as normal.

In the case of incoming messages with a PDE trailer, the 'PDE Flag' check box in the 'Incoming Message Browser' screen will be checked.

*For more details on the PDE indication of an incoming message in the Incoming Message Browser, refer section 'Viewing the details of an Incoming Message' in 'Processing Incoming Messages' chapter of this User Manual.*

### 3.7.1.2 Outgoing PDE Messages

In the case of outgoing messages you can decide to do any of the following if the system detects a message as a duplicate, based on the PDE validations:

- Auto release the message with the PDE trailer
- Release the message without the PDE trailer
- Reject the message

System displays an override when it finds a message to be a duplicate one. In this case the message is parked in the PDE queue and you can either opt to release the message without the PDE trailer or else release it with the PDE trailer. If you opt to release the message with the PDE trailer then the message is appended with PDE, else the message is released without PDE. You can also choose to reject the message. In this case the message status will be changed to 'E' (Exception) and this will not be picked up by EMS (Electronic Messaging System).

Due to message size restrictions in Oracle FLEXCUBE, sometimes a single message is physically split into multiple parts and each one is stored in a distinct record in the outgoing message data store. A message is marked as 'PDE' if ALL the split messages are found to be duplicates.

---

#### **Note**

All the messages in the PDE queue (Incoming and Outgoing) are completely processed by EMS prior to initiating EOD operations.

---

*For more details on outgoing messages in PDE queue refer section 'Processing Outgoing Messages with PDE Trailer' in 'Processing Outgoing Messages' chapter of this User Manual.*

## 3.8 Maintaining Agreements with Sender/Receiver BIC

You can maintain agreement with the sender/receiver BIC through the 'Agreements with Sender/Receiver BIC Maintenance' screen. You can invoke the 'Agreements with Sender/

Receiver BIC Maintenance' screen by typing 'ISDCCYRS' in the field at the top right corner of the Application tool bar and clicking the adjoining arrow button.

You need to capture the following information in this screen:

### **BIC Code**

Specify the BIC code. The value entered here must be a valid BIC code in the system with the options Generate MT102, Generate MT102+ and Generate 101 selected.

### **Message Type**

Select the message type from the option list.

- MT101
- MT102
- MT102+

### **Direction**

Indicate whether the BIC-currencies amount maintenance is for incoming or outgoing or both type of messages. You have the following options here.

- Incoming
- Outgoing
- Both

### **Product for Consol Debt**

Specify the product for consolidated debit entry to ordering customer. This can be specified for incoming MT101.

### **No. of Transactions per Message**

Specify the total number of transactions for each message (MT101).



### **Cutoff Incoming**

Specify the cutoff time in hours and minutes for the incoming messages.

### **Cutoff Outing**

Specify the cutoff time in hours and minutes for the outgoing messages.

## **3.8.1 Transaction Currency Limit Details**

The details displayed here depend on the direction specified. They are used for MT101, MT102 and MT102+.

- If the direction is Incoming, these fields indicate the transaction limit for individual transactions in the incoming message.
- If the direction is Outgoing, these fields indicate the transaction limit for individual transactions in the outgoing message.
- If the direction is Both, these fields indicate the transaction limit for individual transactions in the outgoing and incoming message.

### **Incoming MT101**

If the message is an incoming MT101, on receiving the message the following checks will be made before uploading the transactions.

- If the Sender has an agreement for Incoming MT101.
- If the Cut-off time for Incoming MT101 for the receiver has not passed.
- Check for the Transaction currency & Transaction amount limit.
- Check for the debit authority of the Instructing party, in case the instructing party is different than the ordering customer

---

## 4. Maintaining Media Types

### 4.1 Introduction

Advices and messages are generated at the specified events in the lifecycle of contracts involving the front-end modules of Oracle FLEXCUBE. In the 'Media Maintenance' screen, you should maintain the different media through which these advices and messages would be generated (from and to your bank).

At your bank, you can only receive or route messages through a media that you have maintained in this screen. These specifications can be made only at the main branch and will be applicable to all the branches of your bank.

The Messaging System (MS) Module supports various types of media. Besides standard media modes like Mail, Telex and SWIFT you can also maintain, other media like CHIPS, Email or any other country or customer specific media.

### 4.2 Maintaining Message Media Details

You can invoke the 'Message Media Maintenance' screen by typing 'MSDMEDMT' in the field at the top right corner of the Application tool bar and clicking on the adjoining arrow button.

If you are maintaining details of a new media type, select 'New' from the Actions Menu, or click new icon on the toolbar. The 'Message Media Maintenance' screen is displayed without any details.

If you are calling a Message Media Maintenance record that has already been defined, double-click a record from the summary screen. In the 'Summary' screen, all the media maintenance records that you have entered will be displayed in a tabular form.

The screen is as shown below:

The screenshot shows the 'Media Maintenance' window. It includes a 'Save' button, a 'Media Code \*' field, a 'Description \*' field, 'Media Number', 'Message Suffix', and 'Message Terminator' fields, a 'Number of Characters' field, and a 'Media Priority \*' field. There are also three checkboxes: 'Test Word Required', 'Stop Processing', and 'Padding Required'. A 'Compatible Media' section is visible, showing a table with one row: 'Compatible Media \*'. At the bottom, there is a 'Fields' section with labels for 'Maker', 'Checker', 'Mod No', 'Date Time:', 'Record Status', and 'Authorization Status'. A 'Cancel' button is located in the bottom right corner.

In this screen, you can maintain the following:

- The media types that can be used to transmit messages from and to your bank, and
- The compatible media for the media type you are maintaining.

## 4.3 Features of the Media Maintenance screen

For each media type that you maintain, you should indicate the following parameters:

### Indicating a Code to Identify a Media Type

In Oracle FLEXCUBE, each media type that you maintain is identified with a fifteen-character code called 'Media Code'. You can follow your own convention for devising this code. A Media Type could be SWIFT, Mail, Telex, etc.

The code that you assign a media type should be unique as it is used to identify the media. When you need to indicate that a message should be transmitted through a particular media type, you just need to specify the code assigned to the media type. The message will be routed automatically through the media.

You can enter a short description of the media type that you are maintaining. The description will help you identify the code that it represents.

### Opting for Message Markers

You can opt to append end-message markers to outgoing messages generated in a media. These markers are referred to as "Padding Characters" in Oracle FLEXCUBE. Padding characters would, typically, be a standard set of characters, probably repeated. The padding characters that you specify will be inserted, automatically, at the end of every outgoing

message in the media. You can indicate the padding characters that mark the end of an outgoing message (in a specific media) in the Message Suffix field.

When defining a media, you can also capture the padding characters that mark the end of incoming messages in the media. The system identifies the end of an incoming message, in a file containing several messages, when it encounters the padding characters you have captured for a media type. Enter the padded characters that mark the end of incoming messages in a media in the Message Terminator field.

---

**Note**

For Message suffix to be used for Outgoing messages, the 'Padding Required' option should be selected.

---

**Repeating a Set of Padding Characters**

If you opted to suffix an outgoing message with a set of padding characters, indicate in the 'Number of Characters' field the number of times the set should be repeated.

The padding characters will be suffixed to every outgoing message in the media as many times as you specify.

**Halting the Processing of Messages**

At any time, you can opt to halt the processing of messages in a specific media. To halt the processing of incoming and outgoing messages in a media, invoke this screen and navigate to the maintenance record for the media, and choose the 'Stop Processing' option. When you save your changes to the record, Oracle FLEXCUBE will stop processing messages in the media.

**Indicating the Compatible Media for a Media Type**

For each media type that you maintain, you can also indicate other media that are compatible. The format of compatible media should be similar.

For example, you are maintaining details for the media type 'mail'. You have indicated media type 'Fax' as compatible media.

In this case, whenever a message is faxed, it will be in the mail format defined for the message in the 'Advice Format File Maintenance' screen.

You can indicate compatible media by selecting the relevant media codes from the picklist available. To add compatible media for a media type, select the code that identifies the compatible media, and click add icon. To delete compatible media, select the codes that identify the media, and click delete icon.

---

**Note**

The compatible media that you indicate for a media type should have already been maintained as a media type.

---

**Setting the Priority**

While maintaining media types, you can set the usage priority for each media type that you maintain. Consequently, when dispatching messages to customers, the media type used for sending the message will be the one that is higher on the priority rating. For instance, let us assume that the following are the types of media that you bank uses to send advices to customers:

- SWIFT

- Mail
- Telex
- Fax

You have assigned the following priority to each of these media types:

Media Type	Media Priority
SWIFT	2
Mail	1
Telex	4
Fax	3

When dispatching messages to customers, the system will, by default, select the media type in the ascending order of the priority that you have specified.

---

**Note**

The rating that you specify can be anything between 1 and 99. A rating of one would indicate that the usage of the particular media type is highest on the priority list; whereas, a rating of 99 indicates that the usage of the particular media type is of lowest priority.

---

**Saving the Record**

After you have made mandatory entries, save the record. A media maintenance record that you have created should be authorized by a user, bearing a different Login ID, before the End of Day processes are triggered. Click 'Exit' or 'Cancel' button to return to the application.

## 4.4 Maintaining Message Locations

You can maintain the message locations using the 'Message Location Maintenance' screen. You can invoke this screen by typing 'MSDLOCMN' in the field at the top right corner of the Application tool bar and clicking on the adjoining arrow button.

The 'Message Location Maintenance' screen is shown below:

Fields	
Maker	Date Time:
Checker	Date Time:
Mod No	Record Status
	Authorization Status

You can specify the following here:

**Code**

Specify the location code.

**Code Description**

Enter a description of the location code.

After entering the details, click the 'Save' button.

## 4.5 Maintaining SWIFT Characters

You can maintain the SWIFT characters using the 'SWIFT Character Maintenance' screen. You can invoke this screen by typing 'MSDSWFCR' in the field at the top right corner of the Application tool bar and clicking on the adjoining arrow button.

The 'SWIFT Character Maintenance' screen is shown below:

The screenshot shows a window titled "SWIFT Character Maintenance". At the top left, there is a "Save" button. Below it, there are two input fields: "Main Character \*" and "Substitute \*". At the bottom of the window, there is a "Fields" section with labels: "Maker", "Checker", "Mod No", "Date Time:", "Date Time:", "Record Status", and "Authorization Status". A "Cancel" button is located in the bottom right corner.

You can specify the following here:

**Main Character**

Specify the main character.

**Substitute**

Specify the substitute for the main character.

After entering the details, click the 'Save' button.

## 4.6 Maintaining Email Overrides

You can maintain the email overrides using the 'Email Overrides' screen. You can invoke this screen by typing 'MSDMLOVR' in the field at the top right corner of the Application tool bar and clicking on the adjoining arrow button.

The 'Email Overrides' screen is shown below:

The screenshot shows the 'Email Overrides' application window. At the top, there is a 'Save' button. Below it are two input fields: 'Override Code \*' and 'Language Code \*', each with a dropdown arrow icon. The main area is titled 'Email Override Detail' and contains a table with one row and one column labeled 'E-mail Address \*'. The table has a 'Go' button and navigation icons. At the bottom, there is a 'Fields' section with labels: 'Maker', 'Checker', 'Mod No', 'Date Time:', 'Date Time:', 'Record Status', and 'Authorization Status'. A 'Cancel' button is located in the bottom right corner.

Click the Enter Query button to enter the following query criteria.

**Override Code**

Specify a valid override code. The adjoining option list displays all valid override codes maintained in the system. You can select the appropriate one.

**Language Code**

Specify a valid language code. The adjoining option list displays all valid override codes maintained in the system. You can select the appropriate one.

**E-mail Address**

Specify a valid email address.



---

## 5. Maintaining Media Control Systems

### 5.1 Introduction

The messages that are sent from and delivered to your bank are transmitted and received over sources that are external to Oracle FLEXCUBE. We shall call these external sources Media Control Systems (MCS).

In a distributed environment, the database of a branch is located in a node or server. The MCS of the messages are also installed in a node. Thus, while defining an MCS, you also need to indicate the node in which it is installed.

An MCS can handle only one media, hence you need to set up several media control systems for the various media types maintained for your bank. Apart from indicating the media type for an MCS, you can indicate separate directories from which Oracle FLEXCUBE should read and write incoming and outgoing messages for a given media.

You can maintain MCS details in the 'Message Media Control Maintenance' screen. The details that you specify in this screen control the medium of delivery and reception of messages.

### 5.2 Maintaining Message Media Control

You can invoke 'Message Media Control Maintenance' screen by typing 'MSDMGMCS' in the field at the top right corner of the Application tool bar and clicking on the adjoining arrow button.

If you are maintaining details of a new media control system click the 'New' button on the Application toolbar. The 'Message Media Control Maintenance' screen is displayed without any details.

If you are calling an MCS record that has already been defined, double-click a record of your choice from the summary screen. In the 'Summary' screen, all the media control system records that you have entered will be displayed in a tabular form.

The screen is as shown below:

The screenshot shows a software window titled "Message Media Control Maintenance". The window contains several input fields and a dropdown menu. The fields are: "Node \*", "Media Control System \*", "Media \*", "Status Movement" (dropdown menu set to "Active"), "Delivery Type" (radio buttons for "Folder" and "Queue"), "In Directory", "Out Directory", "File Prefix", "Unix In-Directory", "Unix Out-Directory", "In Queue", and "Out Queue". There are also radio buttons for "Unix Swift Server", "Microsoft Message Queue", and "WebSphere". At the bottom, there is a "Fields" section with labels for "Maker", "Checker", "Mod No", "Date Time:", "Record Status", and "Authorization Status". An "Exit" button is located in the bottom right corner.

## 5.3 Features on MCS Detailed Screen

You can capture the following details on this screen.

### Delivery Type

You can specify the delivery type here. Oracle FLEXCUBE gives you two options viz. Folder and Queue. Depending on the selection you make, you must specify the details in the corresponding fields as follows.

- Folder – If you choose 'Folder' as the delivery type, you must specify the In Directory and the Out Directory. Further, after selecting 'Folder', if you check the option 'Unix Swift Server' for a UNIX SWIFT server, then you must specify the Unix In-Directory and the Unix Out-Directory. For a Windows Server the In-Directory and Out-Directory must be maintained.
- Queue – If you select 'Queue' as the delivery type, you must specify In Queue, Out Queue and the type of queue – i.e. 'Microsoft Message Queue' or 'WebSphere Messaging Queue'.

### Media Control System

In Oracle FLEXCUBE, each media control system that you maintain is identified by a 15-character code called an MCS code. You can follow your own convention for devising this code.

The code that you assign an MCS should be unique as it is used to identify the external source.

### Node

A node is the Database instance on which Oracle FLEXCUBE is installed. On assigning a code to an MCS, you can indicate the node or server at which the MCS is located. A branch's database is located in a node and an MCS is also installed in a node. Thus, while defining an MCS, you need to indicate the node at which it has been installed.

## Media

You need to also specify the media for which your bank is using the MCS. For example, if you set up an MCS say 'MCSSWIFT' and indicate the media type as SWIFT, it indicates that Oracle FLEXCUBE can receive and transmit SWIFT messages through the MCS 'MCSSWIFT'.

The following diagram illustrates a typical MCS setup:

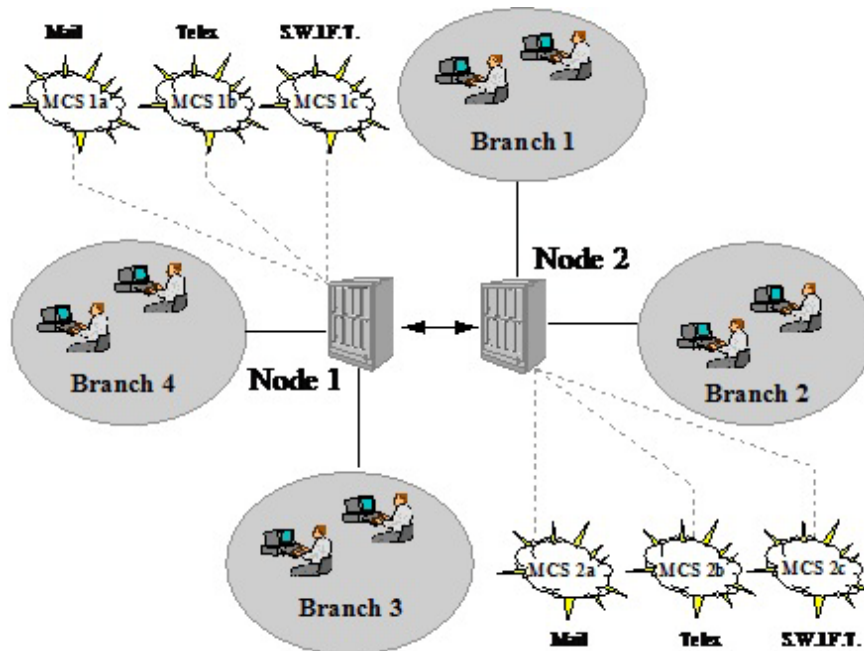

## Status Movement

You need to indicate the status of an MCS. The status options available are:

- Active and
- Passive

It is only when an MCS is active that messages will be directed to it. If, for instance, an MCS located at the node in which your branch operates malfunctions, you can indicate that the MCS is passive. In this case, Oracle FLEXCUBE will not write into or read from the directories on the node. No message will be routed through a passive MCS.

## In Directory and Out Directory

If the Delivery Type is 'Folder' and the SWIFT server is a Windows server then apart from indicating the node on which an MCS is located, you should specify the full path of the directories from which Oracle FLEXCUBE should read and write incoming and outgoing messages respectively.

## File Prefix

For the MCS you are maintaining, you should identify the outgoing message files generated in a different media with unique prefixes. Enter the unique identifier in this field.

## In Queue

If the Delivery type is Queue then you should enter the full path of the queue in the node or server into which the MCS should store the incoming message hand-off file. Oracle FLEXCUBE, by default, will pickup and read all incoming messages transmitted through the specified media from this queue.

### **Out Queue**

Enter the full path of the queue in the node or server into which the message hand-off file from Oracle FLEXCUBE for the specified media should be stored. The MCS, which is also, located on the same node, will by default store the outgoing messages in this queue.

### **Unix Swift Server**

At your bank, if the SWIFT server is on UNIX, check this option. Subsequently, in this screen, you should specify the default In and Out Directories for the SWIFT message hand-off files.

To continue with your normal banking operations you can connect to another node and indicate the directory on that node from which Oracle FLEXCUBE should read from and write into.

## **5.3.1 SWIFT Server on UNIX**

If the SWIFT server at your bank is on UNIX, you should indicate it in this screen. Subsequently, you should specify the default In and Out Directories for the SWIFT message hand-off files.

### **Specifying the UNIX In-Directory**

You can specify the full path of the directory on the SWIFT server where you would like to store incoming SWIFT message files. Oracle FLEXCUBE will pickup and process all incoming SWIFT message files from this directory.

### **Specifying the UNIX Out-Directory**

In this screen, you can also specify the directory on the SWIFT server where you would like to store outgoing SWIFT message hand-off files.

## **5.3.2 Specifying File Prefix**

For the MCS you are maintaining, you should identify outgoing message files generated in the media with unique prefixes. Oracle FLEXCUBE will automatically prefix outgoing message hand-off files for the MCS with the prefix that you specify.

## **5.3.3 Saving Details you have Maintained**

After you have made the mandatory entries, save the record. An MCS record that you have created should be authorized by a user, bearing a different Login ID, before the End of Day process (EOD) is run.

---

## 6. Maintaining Addresses for Customer

### 6.1 Introduction

The messages and advices that are sent to the customers of your bank can be transmitted to various addresses through the media types that you maintain in the 'Media Maintenance' screen. In this 'Address Maintenance' screen, some of the details that can be maintained are:

- the media through which messages to a customer should be transmitted
- the address(es) of a customer for each media type
- the answer-back code for a telex advice
- a 'Test Word' for the customer
- the messages that should be sent to an address
- the language in which messages should be sent to a customer address
- specifying the Delivery By as 'FILEFACT' while maintaining the Customer Address Information for MT 102 Type of messages.

A customer of your bank can have several addresses for a given media. To distinguish between one address and another for the same media, you can capture an address for every 'Location'.

---

#### **Note**

The addresses that you maintain for a customer in this screen are in addition to the ones maintained in the Customer Information File (CIF) of the Core module.

---

### 6.2 Customer Account Address Maintenance Screen

You can invoke the 'Account Address Maintenance' screen by typing 'MSDCACAD' in the field at the top right corner of the Application tool bar and clicking on the adjoining arrow button.

The 'Account Address Maintenance' screen is shown below:

The screenshot shows the 'Account Address Maintenance' application window. The title bar reads 'Account Address Maintenance'. Below the title bar is a toolbar with 'New' and 'Enter Query' buttons. The main content area is split into two sections: 'Customer Details' and 'Message Address'.  
**Customer Details:** This section contains several input fields and checkboxes. On the left, there are fields for 'Branch Code', 'Account No', 'Location', 'Country', 'Answerback', 'Name', 'Address Code', 'Address', 'Prefecture', and 'Pincode'. On the right, there are fields for 'Media', 'Language', 'Test Keyword', and 'Delivery By'. Below these are checkboxes for 'Add Hold Mail Text', 'Mark For Expiry', and 'Default Address'.  
**Message Address:** This section contains a table with the following columns: 'Module', 'Message Type', 'No of Copies', 'Format', and 'Primary Address'. The table is currently empty. Above the table is a navigation bar with '1 Of 1' and a 'Go' button.  
**Status Bar:** At the bottom of the window, there is a status bar with fields for 'Maker', 'Checker', 'Date Time', 'Mod No', 'Record Status', and 'Authorization Status'. An 'Exit' button is located on the far right of the status bar.

If you are querying for a customer address record that has already been defined, select the 'Summary' option under 'Account Address'. In the View screen, all the customer address records that have been maintained so far will be displayed in a tabular form. Double-click a record to open it.

If you are maintaining a new address for an account select 'New' from the Actions Menu, or click new icon on the toolbar. The screen is displayed without any details.

If you are modifying some of the details of the existing record, select the 'Unlock' option from the Actions Menu and proceed.

### Customer Account Number

It is the relevant customer account number in the current branch against which you are maintaining an address, based on a selected media and location. The branch code gets defaulted alongside.

A single customer can have any number of accounts. You can choose to link a specific location with an account number. Maintaining multiple locations for the customer facilitates the sending of interest and account statements to more than one address of the customer.

If an address is maintained at the Customer Account Definition level, all statements pertaining to the particular account will be sent only to the address specified at the account level, irrespective of the message and location maintenance for the Customer.

### Media

Select the media code for which you want to set-up addresses. Choose a code from the option-list of valid media codes maintained in the 'Media Maintenance' screen.

A customer of your bank can have several addresses for a particular media. The media supported include:

- Mail
- E-Mail
- Telex
- SWIFT
- FAX
- FILEACT (this is an interface to the TIPA network)

Each media type is identified by a 15 character Media Code.

### **Location**

As discussed earlier, a customer of your bank can have several addresses for the same media. To differentiate between one address of a customer account and another for a given media, it is mandatory for you to select a unique location for each address. The location that you specify for an address is used as a unique identifier for the customer account address.

The values made available against the option list here are maintained through the 'Account Address Location Maintenance' screen.

*Refer to the section 'Location Maintenance' in the chapter titled 'Maintaining Customer Accounts' in the Core Entities (CE) User Manual for relevant information.*

### **Language**

In this screen you can specify the language in which the messages sent to the address should be expressed. You can choose a language code from the factory shipped option list available for this field.

The language code that you specify is taken to be the default language in which all messages sent to the address will be expressed.

---

#### **Note**

To send a message to a customer in a particular language you should have also maintained a message format for the language in the 'Advice File Maintenance' screen.

---

### **Country**

Here, you select the relevant country code where your customer resides. All countries maintained through the 'Country Name Maintenance' screen are made available here.

### **Test Keyword**

Specify the test word allotted to a customer. This field is applicable only if the message is transmitted through Telex (ie. media is TELEX).

### **Answerback**

Specify the answerback code for the customer. This field is applicable only if a message is transmitted through 'Telex'. It cannot be more than 20 characters in length. It is a free format text.

### **Deliver By**

Select how statements sent to the customer by mail should be delivered from the adjoining option list.

All the values maintained through the 'Message Location Maintenance' screen will be displayed in the option list.

### **Add Hold Mail Text**

If this option is checked, then all the mail advice generated for this customer and location would have the hold mail text displayed on top of the message. As a consequence, these mail advices would not be dispatched to the customer unless required. Check this box to indicate you want the hold mail text to be displayed on top of the message.

To recall, you maintain a hold mail text through the 'Messaging Branch Parameter Maintenance' screen.

---

#### **Note**

This field is applicable only if the media is 'MAIL'.

---

### **Send by E-Mail**

If your customer has an e-mail address, you can opt to capture it by clicking on the box adjacent to the 'Send by E-Mail' option. Enter the e-mail address for the selected customer account, media and location combination in the first line of the Address field. You can capture addresses such as fax, mail, etc, for different media and location combinations.

#### **Name**

The system displays the name for correspondence as maintained in the customer maintenance screen.

#### **Mark for Expiry**

Check this box to enable expiry after a pre-determined time.

#### **Address Code**

Select the address code from the adjoining option list. The address codes as maintained in the 'Address Code Maintenance' screen (STDADMNT) are displayed in the option list. *For more information on the Address Code Maintenance screen, refer to the section 'Maintaining Address Codes Details' in the Core Services User Manual.*

#### **Address**

If an address code is selected in the 'Address Code' field, then the fields 'Address 2' to 'Address 4' are auto populated with the relevant address details mapped to the address code. In this case, the 'Address 1' field is the only field that can be modified.

If an address code is not selected in the 'Address Code' field, then enter the detailed address to which messages and advices generated should be sent to, for a particular customer account under the selected media and location combination. The format of the address depends on the media through which the message is transmitted.

If the address is for the media type 'Mail', you can enter the customers address in the four rows under this field. Each line that you enter can contain a maximum of 35 characters.

If the media of transmission is Telex, the address should be expressed numerically.

If you are defining a SWIFT address, the address should be of eight or eleven characters alphanumeric.

#### **Prefecture**

The system displays the prefecture.

#### **PIN Code**

If an address code is selected in the 'Address Code' field under the 'Address for Correspondence' section, then the PIN code field is auto populated with the value mapped to



the address code. If the address code is not selected in the 'Address Code' field, then specify the PIN code details.

### **Default Address**

If you check against this option, the address specified against the chosen 'Location' and 'Media' combination becomes the default or the primary address of the customer.

Messages and advices generated against the selected customer account are always sent to the primary or the default address of the corresponding customer.

You can maintain multiple addresses at a customer account level through this screen.

You need to specify the following details:

### **Message Address**

#### **Module**

A message type is always associated with a module. In some cases, a message may be associated with more than one module. An example could be a payment message that is generated by the trade, treasury and remittances departments of the bank. Once you select the module, the 'Message Type' gets defaulted alongside.

---

#### **Note**

You can use the wildcard 'All' indicating that all messages for the customer belonging to any module should be sent to the address being defined.

---

In order to generate MT292 on reversal of a contract, you need to maintain the module as 'IS' and the message type as 'REVSWIFT'.

For example, Ms. Keturah Smith has five accounts with Kuber's bank. Three of the accounts were opened at Kuber's bank, London, and two at Kuber's bank Surrey.

Ms. Smith had requested that an account statement be sent to her every month by mail with the following instructions:

- the account statements for the accounts at London should be sent by mail to her residential address at London
- the statements for the accounts at Surrey should be sent to her office address.

In this screen you should indicate:

- **Module + Message Type** -- Accounting (AC) + Account Statement
- **Module** -- All
- **Copies** – 1

You should also maintain a new customer address record for Ms. Smith's Surrey address and a unique location for that address.

#### **Copies**

You can indicate the number of copies of the message that should be sent to this location each time it is generated. The number you specify here, will be the default number of copies of the message that will be generated each time a message is sent to this location through the media you have specified.

If you indicate that more than one copy should be sent to a location, the first message will be the original and the others will be marked as 'copy'.

---

**Note**

For payment messages, Oracle FLEXCUBE will default 'one' indicating that only one payment message will be generated. You will not have an option to change it.

---

**Format**

You can specify the format in which a message should be sent to a customer's address. To recall, you have defined the default format for a message type in through the 'Advice Format Maintenance' screen.

If you leave this field blank the default format specified for a message type in the Advice format screen will be used. However, if you want to personalize a message to make it specific to a customer, you can indicate the code of the format that should be used for the advice - customer combination.

For example, you have maintained a standard format for the account statements that are sent from your bank in the 'Advice Format Maintenance' screen.

However, for Mr. Andrew Scott, a non-resident customer you want to personalize the account statement rather than send him the standard one defined in the advice format screen.

To make this possible you can indicate the code of a format that you defined specific to Mr. Scott. Whenever an account statement is sent to Mr. Scott from your bank, it will be in the format that you have defined in this screen. Please note that the special format should first be defined in the advice format screen before it can be associated with Mr. Scott's address.

**Primary Address**

When defining addresses for a message type, you have to identify an address as the primary address. This option will be available only if the message type is 'FX\_CONFIRMN'.

If you maintain multiple FX Confirmation Message types for the 'SWIFT' Media for a customer across different locations, the T-Copy will be generated only for the address that is marked as the 'Primary Address' of the counterparty.

*Refer the 'Continuous Linked Settlements' chapter of the Foreign Exchange User Manual for details on processing CLS deals in Oracle FLEXCUBE.*

To add additional modules to the list, you can click on the add icon. To delete a row, click on the delete icon.

## 6.2.1 Maintaining Additional Scripts

You can maintain the address details of the account in additional scripts like Kanji, Katakana and Hiragana format by clicking on 'Additional Scripts' button in 'Account Maintenance' screen

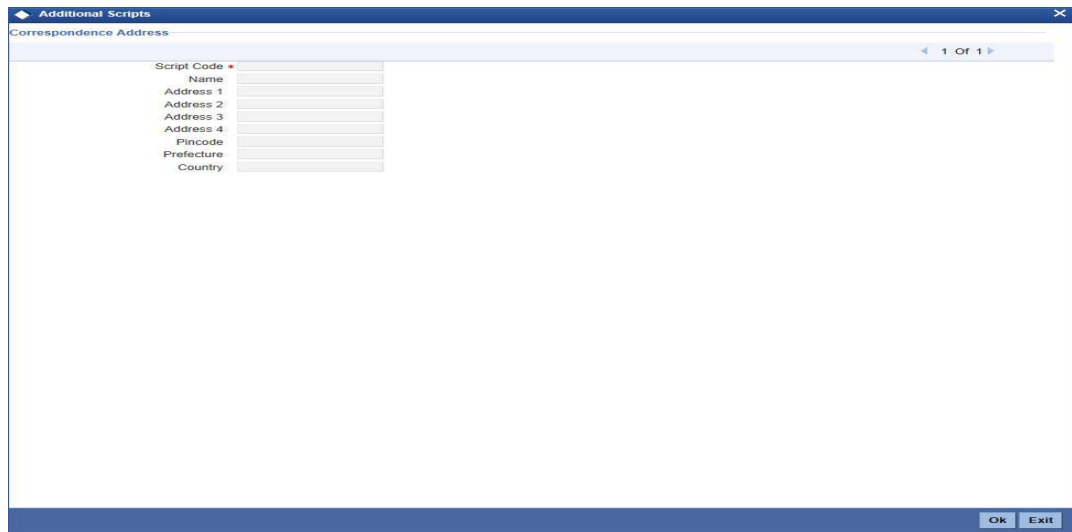

The screenshot shows a window titled 'Additional Scripts' with a sub-header 'Correspondence Address'. The window contains a form with the following fields: 'Script Code' (a dropdown menu), 'Name', 'Address 1', 'Address 2', 'Address 3', 'Address 4', 'Pincode', 'Prefecture', and 'Country'. Each field is represented by a text input box. At the top right of the form area, there is a navigation indicator '< 1 Of 1 >'. At the bottom right of the window, there are 'Ok' and 'Exit' buttons.

Click '+' icon to add additional scripts.

You need to specify the following details:

### Script Code

Specify the script code. Alternatively, you can select the script code from the option list. The list displays the script code, script description, language code and language name of the scripts.

### Name

Specify the full name of the customer in selected script.

### Address 1-4

If the address code input in main screen has details in the script code input by user, then Address 1-3, (*Prefecture & Pin Code*) will be auto populated. If address code is not input or if the address code does not have details in the selected script code, you can manually input these fields. Address 4 is always input manually.

For more information on the Address Code Maintenance screen, refer to the section 'Maintaining Address Codes Details' in the Core Services User Manual.

### Pin Code

If an address code is selected in the 'Address Code' field under the 'Address for Correspondence' section, then the PIN code field is auto populated with the value mapped to the address code. If the address code is not selected in the 'Address Code' field, then specify the PIN code details.

### Prefecture

Specify the prefecture corresponding to the address.

## Country

Specify the country code.

### 6.2.2 Saving Record

After you have made the mandatory entries, save the record. A customer address record that you have created should be authorized by a user, bearing a different Login Id, before the End of Day (EOD) process can begin. Click 'Exit' or 'Cancel' to return to the Application Browser.

### 6.2.3 Address Maintenance at Customer (CIF) Level

You also have the provision to maintain customer addresses at the customer (CIF) level. You can invoke the 'Customer Address Maintenance' screen by typing 'MSDCUSAD' in the field at the top right corner of the Application tool bar and clicking on the adjoining arrow button.

The screen is shown below:

The screenshot displays the 'Customer Address Maintenance' application window. The interface includes a 'Save' button at the top left. The main area is divided into several sections: 'Customer Address' with fields for Customer No, Location, Country, Answerback, Name, Address Code, Address 1-4, PIN Code, and Prefecture; '50F Party Details' with five lines of text input; and a right-hand section with fields for PID No, Media, Language, Test Keyword, and Delivery By, along with a 'Send by Email' checkbox. At the bottom, there is a table with columns: Message Type, Module, Branch, No of Copies, Format, and Account No. The table is currently empty. The footer contains 'Fields | Additional Scripts | Change Log' and a status bar with 'Maker', 'Checker', 'Date Time', 'Mod No', 'Record Status', 'Authorization Status', and a 'Cancel' button.

---

### Note

You can query or modify the customer details whose accounts are permitted to you for the query/modification in the 'Group Code Restriction' screen.

---

If you are maintaining a new address for a customer select 'New' from the Actions Menu, or click new icon on the toolbar. The screen is displayed without any details.

If you are calling a customer address record that has already been defined, double-click on a record from the summary screen. In the 'Summary' screen, all the customer address records that you have entered are displayed in a tabular form.

---

**Note**

Oracle FLEXCUBE generates a notification message when a new customer address is created and authorized. This notification message can be sent to any external system if required.

---

**Customer No**

Specify the customer (CIF) number, assigned to a customer in the 'Customer Information Maintenance' screen, before you capture the different addresses of the customer. The name of the customer whose address you are maintaining is automatically displayed when you indicate the customer's identifier.

You can enter the customer No, customer name, language, country or PID No and click on the 'Search' button. The system then fetches you all the relevant details.

**PID No**

System displays the PID No based on the selected customer number.

**Media**

The types of media for which you can capture addresses include Mail, E-Mail, Telex, SWIFT, FAX and FILEACT interface to TIPA network. The Media details maintained in 'Media Maintenance' screen will appear in the list of values.

**Location**

As discussed earlier, a customer of your bank can have several addresses for the same media. To differentiate between one address of a customer and another for a given media, it is mandatory for you to specify a unique location for each address. The location that you specify for an address is used as a unique identifier for the customer address.

A single customer can have any number of accounts. You can choose to link a specific location with an Account Number. Maintaining multiple locations for the customer facilitates the sending of interest and account statements to more than one address of the customer.

If an address is maintained at the Customer Account Definition level, all statements pertaining to the particular account will be sent only to the address specified at the account level, irrespective of the message and location maintenance for the Customer.

You can choose from the available list and indicate the Account Number, which should be linked with the respective address.

---

**Note**

You are allowed to link a customer address with an account only for a specific branch, which means that the branch should be a valid branch code in the system. If you use the wildcard 'All' indicating that the customer address and account linkage is valid in all the branches of your bank, you will not be able to exercise this option.

---

**Language**

In this field, you can specify the language in which the messages sent to the address should be expressed. You can choose a language code from the option list available against this field.

The language code that you specify is taken to be the default language in which all messages sent to the address are expressed.

---

**Note**

Remember that to send a message to a customer in a particular language you should have also maintained a message format for the chosen language through the 'Advice Format Maintenance' screen.

---

**Country**

Here, you select the relevant country code where your customer resides. All countries maintained through the 'Country Name Maintenance' screen are made available here.

**Answerback**

Specify the answerback code for the customer. This field is applicable only if a message is transmitted through 'Telex'. It cannot be more than 20 characters in length. It is a free format text.

**Test Keyword**

Enter the test word allotted to a customer. This field is applicable only if the message is transmitted through Telex (i.e. media is TELEX).

**Deliver By**

Select how statements sent to the customer by mail should be delivered from the adjoining option list.

All the values maintained through the 'Message Location Maintenance' screen will be displayed in the option list.

**Send by E-mail**

If your customer has an e-mail address, you can opt to capture it by clicking on the box adjacent to the 'Send by E-Mail' option. Enter the e-mail address for the customer, media and location combination in the first Address field. You can capture addresses such as fax, mail, etc., for the combination in the remaining address fields.

**Name**

The system displays the name for correspondence as maintained in the customer maintenance screen.

**Mark for Expiry**

Check this box to mark for expiry.

**Address Code**

Select the address code from the adjoining option list. The address codes as maintained in the 'Address Code Maintenance' screen (STDADMNT) are displayed in the option list. *For more information on the Address Code Maintenance screen, refer to the section 'Maintaining Address Codes Details' in the Core Services User Manual.*

**Address 1-4**

If an address code is selected in the 'Address Code' field, then the fields 'Address 1' to 'Address 3' are auto populated with the relevant address details. In this case, the 'Address 4' field is the only field that can be modified. If an address code is not selected in the 'Address Code' field, then enter the detailed address to which messages and advices generated should be sent to, for a particular customer account under the selected media and location combination. The format of the address depends on the media through which the message is transmitted.

If the address is for the media type mail, you can enter the customers address in the four rows under this field. Each line that you enter can contain a maximum of 35 characters.

If the media of transmission is Telex, the address should be expressed numerically.

If you are defining a SWIFT address, the address should be of eight or eleven characters alphanumeric.

---

**Note**

The valid address (e-mail or Telex or SWIFT) must be entered in the first line of the Address field only for it to be used.

---

**Add Hold Mail Text**

If this option is checked, then all the mail advice generated for this customer and location would have the hold mail text displayed on top of the message. As a consequence, these mail advices would not be dispatched to the customer unless required. Check this box to indicate you want the hold mail text to be displayed on top of the message indicating the branch.

**PIN Code**

If an address code is selected in the 'Address Code' field under the 'Address for Correspondence' section, then the PIN code field is auto populated with the value mapped to the address code. If the address code is not selected in the 'Address Code' field, then specify the PIN code details.

**Prefecture**

Specify the prefecture corresponding to the address.

**50F Party Details**

Specify the party details related to the ordering customer as a 5-line input here. Line 1 indicates the party identifier and lines 2 to 5 indicate the name and address details of the party.

You can use either of the following line formats with option F:

- Line 1 (Party Identifier) /34x (Account)
- Lines 2-5 (Name & Address) 1!n/33x (Number)(Details)

Or

- Line 1 (Party Identifier) 4!a/2!a/27x4!a/30x (Code)(Country Code)( Identifier)
- Lines 2-5 (Name & Address) 1!n/33x (Number)(Details)

The details specified here are used for a stricter validation of the details related to the ordering customer. The validations are carried out according to the rules indicated below:

- Validations for line1, party identifier (applicable for the second format listed above):
  - Line 1 has to comply with (Code)(Country Code)(Identifier) format where the country code should be a valid ISO country code
  - The first 4 characters specified should be a valid party identifier code supported by SWIFT
- Validations for lines 2 to 5, name and address details of the party:
  - The first line must start with number 1
  - Line numbers must appear in numerical order
  - Line number 2 cannot be used without line number 3 and vice versa
  - Line number 4 cannot be used without line number 5 and vice versa
  - Line number 4 should have the format YYYYMMDD and this date must not be greater than the date on which the message was sent to SWIFT

- Line numbers 3, 5, 6 and 7 should be followed by a valid ISO country code
- Line numbers 3, 4, 5, 6, 7 and 8 should not repeat. Line numbers 1 and 2 can repeat.
- Line 8 is used as additional information. When the account identifier format is used, then in the case of Line 8 being used, either line 6 or line 7 should be used. When the party code identifier format is used, then Line 8 can be the continuation of line 1, line 6 or line 7. Line 6 or 7 need not be mandatorily be used

During contract input, the ordering customer record is searched in the customer addresses maintained and if found the corresponding 50F details are defaulted to the contract. If not found, the address details default from customer maintenance.

These validations are carried out for the following outgoing message types and appropriate error messages are displayed incase of any mismatches.

- MT101
- MT102
- MT102+
- MT103
- MT103+
- MT210
- MT910

### 6.2.3.1 Specifying Message Address

For a customer address - message type combination, you can indicate the branch (es) from which the message can be sent to the address. With Oracle FLEXCUBE, you can offer your customers the facility to effect a transaction from any of the branches of your bank. Hence, you can indicate the branches from where a message should be generated. You can select a branch code from the option list that is available.

---

#### **Note**

You can use the wildcard 'All' indicating that the message can be sent to the address in the defined format from all the branches of your bank. For example, if you indicate 'All' in the branch field for the message type 'payment message' it would mean that the address is applicable whenever a payment message is generated from any of the branches of your bank.

---

#### **Message Type**

A message type is always associated with a module. You should indicate the messages to be sent to the address you have defined for the customer, by picking up the message types for the respective module.

---

#### **Note**

You can use the wildcard 'All' indicating that all messages for the customer should be sent to the address being defined.

---

For example, Ms. Keturah Smith has five accounts with Kuber's bank. Three of the accounts were opened at Kuber's bank, London, and two at Kuber's bank Surrey.

Ms. Smith had requested that an account statement be sent to her every month by mail with the following instructions:



- the account statements for the accounts at London should be sent by mail to her residential address at London, and
- the statements for the accounts at Surrey should be sent to her office address.

In this screen you should indicate:

- **Module + Message Type** -- Accounting (AC) + Account Statement
- **Branch** -- London
- **Module** -- All
- **Copies** – 1

You should also maintain a new customer address record for Ms. Smith's office address and a unique location for that address. Under that maintenance, a similar record to the one indicated above (Module – AC, Message Type – Account Statement) needs to be saved for the Surrey Branch.

### **Copies**

You can indicate the number of copies of the message that should be sent to this location each time it is generated. The number you specify here, will be the default number of copies of the message that will be generated each time a message is sent to this location through the media you have specified.

If you indicate that more than one copy should be sent to a location, the first message will be the original and the others will be marked as 'copy'.

---

### **Note**

For payment messages, Oracle FLEXCUBE will default 'one' indicating that only one payment message will be generated. You will not have an option to change it.

---

### **Format**

You can specify the format in which a message should be sent to a customer's address. The default format for a message type needs to be defined through the 'Advice Format Maintenance' screen.

You can choose to use the default format defined for the message type or you can indicate another format for the message. If you leave this field blank the default format specified for a message type in the Advice Format screen will be used. However, if you want to personalize a message to make it specific to a customer, you can indicate the code of the format that should be used for the advice - customer combination.

For example, you have maintained a standard format for the account statements that are sent from your bank in the Advice Format screen.

However, for Mr. Andrew Scott, a non-resident customer you want to personalize the account statement rather than send him the standard one defined in the Advice Format screen.

To make this possible you can indicate the code of a format that you defined specific to Mr. Scott. Whenever an account statement is sent to Mr. Scott from your bank, it will be in the format that you have defined in this screen. Please note that the special format should first be defined in the advice format screen before it can be associated with Mr. Scott's address.

### **Primary Address**

When defining addresses for a message type, you have to identify an address as the primary address. This option will be available only if the message type is 'FX\_CONFIRMN'.

If you maintain multiple FX Confirmation Message types for the 'SWIFT' Media for a customer across different locations, the T-Copy will be generated only for the address that is marked as the 'Primary Address' of the counterparty.

*Refer the 'Continuous Linked Settlements' chapter of the Foreign Exchange User Manual for details on processing CLS deals in Oracle FLEXCUBE.*

---

**Note**

If addresses at both the customer account level and the customer (CIF) level are maintained, Oracle FLEXCUBE picks up the maintenances done at the customer account level to generate messages and advices. However, if the addresses at an account level are not maintained, Oracle FLEXCUBE picks up the maintenances done at the customer (CIF) level to generate messages and advices.

---

### **6.2.3.2 Viewing Previous Addresses**

You can view the customer's previous addresses and changes made to the address using the 'View' screen. You can also determine the number of changes made to the address till date, who made the changes, when was the change made, and whether the change has been

authorized or not. To invoke this screen, click 'Change Log' button within the 'Customer Address Maintenance' screen.

The screenshot shows a 'View' window with the following sections:

- Records:** A table with columns: Modification Number, Modification Status, First Authorization Status, Authorization Status, Maker ID, and Maker Date S. The first row contains: 1, N, A, Unauthorized, DOCUMEN2, 2012-11-07 1.
- Remarks:** Four text input fields: Maker Remarks, First Checker Remarks, Maker Override Remarks, and Checker Remarks.
- Warnings:** A table with columns: Warning Code and Warning Description. The table is currently empty.
- Fields:** A table with columns: Field Name, Old Value, and New Value. The table is currently empty.

At the bottom right of the window are three buttons: Accept, Reject, and Cancel.

To view the changes made on a particular date, double-click the 'View Changes' button corresponding to the desired date under 'Maker Date Stamp'. A detailed screen appears containing changes made on the given date.

## 6.2.4 Maintaining Additional Scripts

You can maintain the address details of the account in additional scripts like Kanji, Katakana and Hiragana format by clicking on 'Additional Scripts' button in 'Account Maintenance' screen

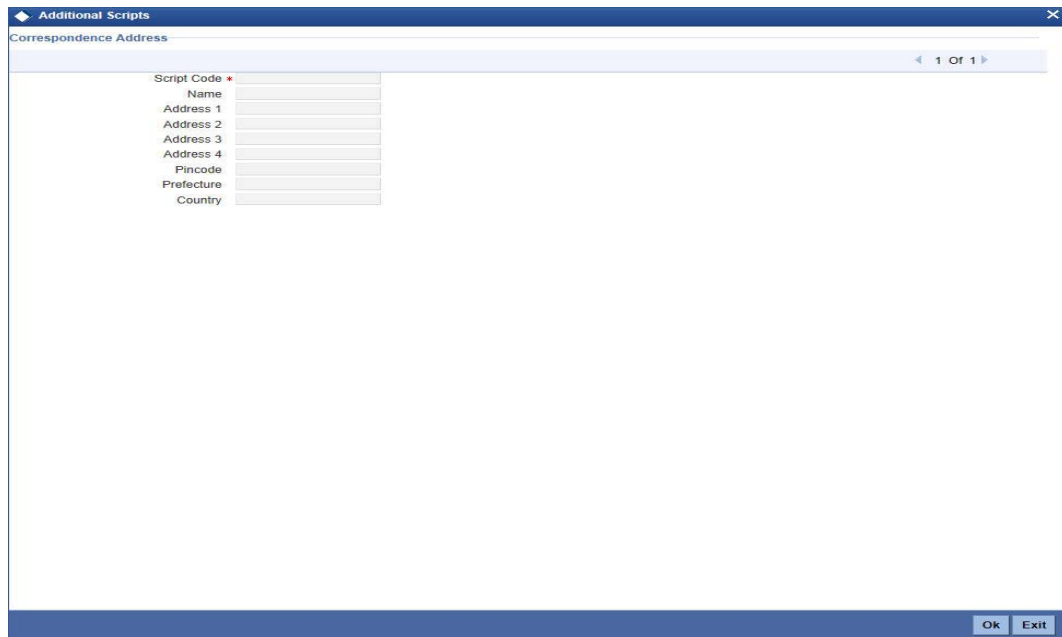

The screenshot shows a window titled 'Additional Scripts' with a sub-header 'Correspondence Address'. The window contains a form with the following fields: Script Code (with a red asterisk), Name, Address 1, Address 2, Address 3, Address 4, Pincode, Prefecture, and Country. A navigation bar at the top right shows '1 Of 1'. At the bottom right, there are 'Ok' and 'Exit' buttons.

Click '+' icon to add additional scripts. You need to specify the following details:

### Script Code

Specify the script code. Alternatively, you can select the script code from the option list. The list displays the script code, script description, language code and language name of the scripts.

### Name

Specify the full name of the customer in selected script.

### Address 1-4

If the address code input in main screen has details in the script code input by user, then Address 1-3, (*Prefecture & Pin Code*) will be auto populated. If address code is not input or if the address code does not have details in the selected script code, you can manually input these fields. Address 4 is always input manually.

*For more information on the Address Code Maintenance screen, refer to the section 'Maintaining Address Codes Details' in the Core Services User Manual.*

### Pin Code

If an address code is selected in the 'Address Code' field under the 'Address for Correspondence' section, then the PIN code field is auto populated with the value mapped to the address code. If the address code is not selected in the 'Address Code' field, then specify the PIN code details.

### Prefecture

Specify the prefecture corresponding to the address.

## Country

Specify the country code.

### 6.2.5 Viewing Customer Address

You can view the address details maintained in the 'Customer Address Maintenance' screen using the 'Customer Address Summary' screen. You can invoke this screen by typing 'MSSCUSAD' in the field at the top right corner of the Application tool bar and clicking on the adjoining arrow button.

The screenshot shows the 'Customer Address Summary' application window. The window title is 'Customer Address Summary'. The interface includes a search bar with 'Case Sensitive' checked, and buttons for 'Search', 'Advanced Search', 'Reset', and 'Clear All'. Below the search bar are input fields for 'Authorization Status', 'Record Status', 'Customer No', 'PID No', and 'Location'. A table below these fields shows a list of records with columns for 'Authorization Status', 'Record Status', 'Customer No', 'PID No', 'Location', and 'Media'. The table is currently empty. At the bottom right of the window is an 'Exit' button.

In the above screen, you can base your queries on any or all of the following parameters and fetch records:

- Authorization Status
- Customer Number
- PID No
- Media
- Record Status
- Location

Select any or all of the above parameters for a query and click 'Search' button. The records meeting the selected criteria are displayed.

---

#### Note

You can query or modify the customer details whose accounts are permitted to you for the query/modification in the 'Group Code Restriction' screen.

---

If you are allowed to query customer information, system displays the following details pertaining to the fetched records:

- Authorization Status
- Record Status
- Customer Number
- PID No
- Location

- Media

## 7. Maintaining Advice Formats

### 7.1 Introduction

The advices that are generated from your bank will have a definite format. In the 'Advice Format Maintenance' screen you can specify formats and indicate the messages and advices that should use the formats you have defined.

By maintaining message formats you can ensure consistency across the branches of your bank. You can maintain advice formats either by:

- Using the format editor on the screen to enter the format, or
- Importing the format from an ASCII file which can be located either on the:
  - Server
  - Client

---

#### Note

Message formats are maintained at the bank level and will be applicable to all the branches of your bank.

---

### 7.2 Advice Format Maintenance Screen

You can invoke the 'Advice Format Maintenance' screen by typing 'MSDADVFM' in the field at the top right corner of the Application tool bar and clicking on the adjoining arrow button.

If you are maintaining a new advice format, click the 'New' button on the Application tool bar. The 'Advice Format Maintenance' screen is displayed without any details.

The screenshot shows the 'Advice Format Maintenance' application window. At the top, there is a 'Save' icon and a 'Format \*' dropdown menu. Below this are 'Language \*' and 'Format Type' dropdown menus, and an 'Import File' text box with an 'Import' button. To the right, 'Lines' is set to 54 and 'Columns' is set to 80. A large 'Format Text \*' text area is present. Below this is a 'Message Format' table with columns: Module \*, Message Type \*, Media \*, Branch \*, Currency \*, and Product \*. The table has one row with checkmarks in the first two columns. At the bottom, there is a 'Fields' section with labels: Maker/Checker, Date Time, Mod No, Record Status/Authorization Status, and a 'Cancel!' button.

You can specify the following details pertaining to a format.

### Format

In Oracle FLEXCUBE, each format that you define is identified by a fifteen-character code called a Format code. You can follow your own convention for devising this code.

The code that you assign to a format should be unique as it is used to identify the format. You can compare simple conditions while defining message formats. When you need to use a format that you have defined, you need to just specify the code assigned to the format. The details of the format will automatically become applicable to the message. After you assign a code to a format you can indicate:

- The number of lines that should be contained in a page when the advice is printed.
- The number of columns that should be contained in a page when the advice is printed.
- The language of the message.
- The form type attached to the format.

### Language

A message can be sent to a customer in different languages. To make this possible, you need to maintain a format in different languages. While maintaining addresses for a customer in the 'Customer Address Maintenance' screen you can indicate the format and language in which a message should be sent.

---

#### Note

You should maintain Advice format in the languages maintained in 'Language' field in 'Main' tab of Customer Maintenance web page dialogue (fast path (STDCIF) for customers of the Bank, in addition to advice format maintained in 'ENG' (English).

---

### Format Type

Specify the format type that applies to the message. Select a format type from the adjoining option-list.

### Entering an advice format using the format editor

To enter a format using the format editor, click free format text icon positioned next to Format Text. In the note pad that is invoked you can actually tailor an advice to suit your requirements. The format editor has certain keywords which signify different options which you can use to create a format. The following table contains a comprehensive list of the key words that can be used in the format editor.

Keyword	Significance
#RH	Indicates the start of the report header section.
#PH	Indicates the beginning of the header for a page.
#EH	Indicates both the end of the header section of the report or the end header of a page.
#RF	Indicates the start of the report footer section.
#PF	Indicates the start of the footer of a page.
#EF	Indicates both the end of the footer of a report or page.
#B	Indicates the start of the body of the message.



#EB	Indicates the end of the body of the message.
#CL	Indicates that you can collapse a line.
#EC	Indicates the end of a line that you have collapsed.
#LOOP	Indicates the beginning of a loop.
#END- LOOP	Indicates the end of a loop.
#IF	Indicates a conditional section.
#ANDIF	Indicates a conditional section.
#ORIF	Indicates a conditional section.
#ENDIF	Indicates the end of a conditional.

#### **Importing an advice format from an ASCII file on the server**

The server indicates the machine on which the database of your bank is installed. To import a format from an ASCII file on the server:

1. Click against the field marked Server.
2. Specify the full path to the file on the server which contains the format you want to import.
3. Thereafter, click 'Import' button.

The file containing the format of the message will be displayed on the screen.

#### **Importing an advice format from an ASCII file on the client**

Client refers to your own machine. To import a format from an ASCII file on the client:

1. Click against the field marked Client.
2. Specify the full path to the file on the client which contains the format you want to import.
3. Thereafter, click 'Import' button.

The file containing the format of the message will be displayed on the screen.

### **7.2.1 Indicating Messages that should Use Format**

After you have defined a format and assigned it a code you can indicate the list of messages that should use the format.

The format that you define for a message in this screen is taken to be the default format that will be used whenever the message is generated from your bank.

For each message that you specify, you can also indicate the specific details of the following, for which the format should be used:

- Module
- Message Type
- Media
- Branch
- Currency
- Product

Thus, you can specify a different format for the various combinations of the above.

---

**Note**

If the 'Module' is selected as CA, then the account class type with 'Currents' and 'Savings' will be listed in the 'Product' field.

If the 'Module' is selected as TD, then the account class type with 'Deposit' will be listed in the 'Product' field.

---

To add a message to the list of messages that can use the format, enter the details of the message and click add icon. To delete a message from the list, select the message and click delete icon.

---

**Note**

For all the five combinations you can use the wildcard 'ALL' indicating that the format is applicable for records in that category. For example, if you indicate 'ALL' in the branch field for the message type payment message it would mean that the format is applicable whenever a payment message is generated from any of the branches of your bank.

---

**Saving the record**

After you have made the mandatory entries, save the record. A user, bearing a different Login ID should authorize an advice format maintenance record that you have created, before the End of Day processes (EOD) are begun.

Click 'Exit' or 'Cancel' button to return to the Application Browser.

In the summary screen, all the advice format records that have already been saved, will be displayed in a tabular form; double-click a record of your choice to open it. You can also invoke this screen by typing 'MSSADVFT' in the field at the top right corner of the Application tool bar and clicking on the adjoining arrow button.

## **7.3 Automatic Printing of Advices Generated during EOD Processing**

In addition to generation of advices, Oracle FLEXCUBE automatically prints the advices that are scheduled to be generated during End Of Day (EOD) processing. Account Statements, Loan statements are examples of advices that are scheduled to be generated during EOD processing.

### **7.3.1 Starting the Background Process**

In Oracle FLEXCUBE, you need to run the background process to generate and print advices. In addition to the generation of the advices, system will also print the advices that are scheduled to be generated during EOD processing. You can start or stop a process in the 'Jobs Browser' screen. You can invoke the 'Jobs Browser' screen by typing 'CSSJOBBER' in the field at the top right corner of the Application tool bar and click on the adjoining arrow button.

The screen is as shown below:

The screenshot shows a 'Summary' window with the following elements:

- Search filters: Job Module (dropdown), Process (text input), Status (dropdown).
- Search buttons: Search, Advanced Search, Reset.
- Pagination: Records per page (15), 1 Of 1, Go.
- Table header: Job Module, Process, Process Sequence Number, Status.
- Table body: (Empty)
- Control buttons: Start, Stop.
- Status legend: Status N - Stopped T - Running H - Halted.
- Exit button.

In the above screen, you can base your queries on any or all of the following parameters and fetch records:

- Job Module
- Process
- Status

Select any or all of the above parameters for a query and click 'Search' button. The records meeting the selected criteria are displayed.

System displays the following details pertaining to the fetched records:

- Job Module
- Process
- Process Sequence Number
- Status

Check the required process in the search results table and click 'Start' button to start the process. Click 'Stop' button to stop the process, at any point.

### 7.3.2 Printing of Advices

In Oracle FLEXCUBE, advices are generated during batch processing. If you have started the background process, system will search for the messages that are not generated. The advices may be of two kinds:

- Advices that are not generated during contract authorization (If you had not opted for message generation at the time of contract authorization)
- Advices that are scheduled to be generated during End of Day operations.
- As soon as the message is generated, system will check whether the advice was scheduled to get generated during EOD. If so, the advice will be sent for spooling and printing.

If the advice is not scheduled to be generated during EOD, system will move on to generate the next advice without printing the advice.

---

## 8. Processing Outgoing Messages

### 8.1 Introduction

Here, the procedure involved in generating an outgoing message is explained. To recall, you have already maintained:

- The type of messages that can be generated at your bank
- Formats for the various messages
- The media through which messages should be transmitted
- A media control system to receive and transmit messages for a given media
- The addresses for a customer for a given media

In each module of Oracle FLEXCUBE, you can define products. While defining products you also indicate the messages that should be associated with an event in the life cycle of a contract involving the product.

A contract goes through several events during its life-cycle. A message for an event is triggered for generation when the event is authorized.

For example, you have defined a product to cater to short term loans. You have indicated that the following messages should be generated when events take place:

Event	Message
INITIATION	Initiation Advice
LIQUIDATION	Liquidation Advice

When you initiate a short-term loan involving the product an Initiation Advice will be triggered for generation. Similarly, if you make a repayment on the loan, the liquidation advice defined for the event will be triggered for generation.

---

#### **Note**

In this context advices and messages are commonly referred to as messages.

---

Depending on the product - message - customer details that you have set up, Oracle FLEXCUBE determines the address and the media through which the message should be transmitted.

If a message is to be transmitted through mail, it has to be printed. If the message is to be transmitted through Telex, you will have to enter the testword (if it is required for the message). The messages that are to be transmitted through media like Telex and SWIFT will be sent by the Media Control System (MCS) which is connected to the node in which the database of your branch is installed.

A message that is triggered for generation can be sent in the background or can be generated on-line. An outgoing message will be processed based on the preference that you state.

---

### Note

The messages that are triggered by an automatic event like the generation of a tracer for an LC, billing notice and delinquency notice for a loan, etc., will be put in the Outgoing Browser by the automatic function itself. This is because events triggered by an automatic function do not require authorization.

---

## 8.2 Manual Generation of Outgoing Messages

If the background message process is not running, all the messages that are triggered for generation will be displayed in the Outgoing Message Browser from where you can generate the message.

You can generate messages from the Outgoing Browser at any time in the day. You can invoke the 'Outgoing Message Browser Summary' screen by typing 'MSSOUTBR' in the field at the top right corner of the Application tool bar and clicking on the adjoining arrow button.

The screenshot displays the 'Outgoing Message Browser Summary' application window. The window has a title bar with a diamond icon and the text 'Outgoing Message Browser Summary'. Below the title bar, there is a search area with the text 'Search Is Case Sensitive'. The search area contains two columns of fields: the left column includes Branch, Reference Number, Message Type, Media, Hold/Release Status, and Authorization Status; the right column includes Document Number, Module, Receiver, SWIFT Message Type, Acknowledgement Status, and Delivered Status. Below the search area, there are buttons for Search, Advanced Search, Refresh, and Reset. A table header is visible with columns: Branch, Document Number, Reference Number, Module, Message Type, Receiver, Currency, Amount, and Mer. The table body is currently empty. At the bottom of the window, there is a toolbar with buttons for Generate, Hold, Cancel, TW Input, Change Node, Change Address, Print, Undo, Change Priority, Resend, Release, Reinstate, TW Auth, Change Media, Change Branch, View, Authorize, Handoff, Details, On-Line Auth, Copy, Carry Forward, BIP Advice File Format, Spool, and an Exit button.

You can view features of the outgoing messages based on any of the following criteria.

- Branch
- Document Number
- Reference Number
- Module
- Message Type
- Receiver
- PID No
- Media

- Swift Message Type
- Message Status
- Hold/Release Status
- Acknowledgement Status
- Maker ID
- Authorization Status
- Delivered Status
- Maker Home Branch

Click 'Search' button. The system identifies all outgoing messages satisfying the specified criteria and displays the following details for each outgoing message:

- Branch
- Document Number
- Reference Number
- Module
- Message Type
- Receiver
- PID No
- Currency
- Amount
- Media
- Swift Message Type
- Node
- Priority
- Name
- Address
- Address2
- Address3
- Address4
- Location
- Message Status
- Testword
- Exception
- Running number
- Hold/Release Status
- Test Amount
- Test date
- Test Currency
- Test word Narrative
- Acknowledgement Status
- Hold Mail
- External Reference
- Delivery By
- RTGS Network

- Maker ID
- Maker Date Stamp
- Authorized By
- Checker Date Stamp
- Authorization Status
- Once Authorized
- Modification Number
- DCN LIST
- Bulk
- Selected
- Testing Status
- Any or Original
- Original DCN
- Delivered Status
- From Date
- To Date
- Maker Home Branch

RTGS Network will be defaulted for the following message types:

CUST\_TSFR\_RTGS  
 BANK\_TSFR\_RTGS  
 COVER\_RTGS  
 DIRDR\_RTGS

RTGS Message type and its description are shown in the table below:

Message	Description	SWIFT Message
CUST_TSFR_RTGS	Used when a Pay message generation is for a corporate and sent through the RTGS Network.	MT 103
BANK_TSFR_RTGS	Used when a message belongs to an interbank deal and sent through the RTGS Network.	MT 202
DIRDR_RTGS	Used when a direct debit message is sent through the RTGS Network.	MT 204
COVER_RTGS	Used when a cover payment is sent through the RTGS Network.	MT 202

---

**Note**

- If none of the criteria is selected, then the system displays all the messages in the outgoing browser.
  - Funding Status will be updated during the processing of incoming MT102 and MT109.
-



## 8.2.1 Performing Operations on an Outgoing Message

The operations that you can perform on an outgoing message are determined by the rights that you are assigned with, at Security Management System (SMS) level. If a function in the Outgoing Browser is disabled, then the function is not allowed for the record.

Check the box against the message(s) for which you need to perform an operation and then click the corresponding operation. The action performed will require authorization, if maintained at the Messaging Branch Preferences level.

The following operations can be performed on the outgoing messages:

### **Generate**

Click to generate an outgoing message. You can generate un-generated and repaired messages.

When you click 'Generate', the system checks the contract status for which the message is generated and will not generate a message in the following condition:

- If the contract is reversed
- If the message is on hold
- If the message maintenance is not authorized and the message is moved to repair queue

### **Hold**

Click if you need to temporarily stop generating an outgoing message. Authorizing Supervisor can view details and then release the messages or change their status to Carry Forward, which in turn can be released on further authorization.

---

### **Note**

Messages with Hold status must either be carried forward or released, before you execute the EOD processes at the branch; else the system displays an error message. However, if the message is cancelled, then the system will not display error message, though the status is 'Hold'.

---

### **Cancel**

Click if you need to cancel an outgoing message. You can cancel messages with 'Un-generated' and 'Hold' status.

### **TW Input**

Click if you need to input testword for Telex messages which were moved to 'Repair' status.

### **Change Node**

Click if you need to change the node from which an outgoing message is generated.

In a distributed environment, the database of one or more branches of your bank will be located at a node or a server. Hence a Media Control System will be installed and defined specifying the node at which it is installed.

When you click 'Node', the system displays the details of the individual message providing an option to change the 'Node'. Select the node you need to change from the adjoining option list.

---

### **Note**

MCS status at the node in which the database of your bank is installed should be passive.

---

### **Change Address**

Click if you need to change the address to which an outgoing message has to be sent. Enter the new address to which the message should be sent and click 'OK' to save.

---

#### **Note**

Change of address can be done only before a message is generated.

---

### **Print/Spool**

Click if you need to print an outgoing message. When you click 'Print', option will be provided to select spool or print on-line.

Messages that are transmitted through mail and those cancelled should be printed. You can also choose to print the details of messages transmitted through other media types.

The system provides an option to spool the advices in PDF format. When you click the 'Print/Spool' button, you can view the selected advice in PDF file. You can also view the SWIFT tag description.

### **Undo**

Click if you need to reverse the last action you performed on an outgoing message at 'Outgoing Messages Browser' level

### **Change Priority**

Click if you need to change the priority, for sending a payment message which is yet to be generated.

---

#### **Note**

In the Background, Oracle FLEXCUBE generates messages on the priority basis.

---

### **Resend**

Click if you need to regenerate and resend a message which was generated and sent.

### **Release**

Click if you need to release a message which is on hold.

### **Reinstate**

Click if you need to reinstate cancelled outgoing messages.

### **TW Auth**

Click if you are provided rights to authorize testword entered for a Telex message. While authorizing you have to reenter the testword.

### **Change Media**

Click if you need to change the media through which a message is transmitted, before it would be generated. Media of transmission of a message is changed if there is a failure of the medium at the recipient's end.

---

#### **Note**

The selected media through which a message is transmitted should be available to the recipient.

---

### **Change Branch**

Click if you need to send an outgoing message from another branch. Select the branch to which the message needs to be moved from the adjoining option list.

You change the branch of a message for the following reasons:

- If there is a failure of a medium at the bank's or the counterparty's end
- If the branch is located closer to the location of the customer's address.

### **View**

Click if you need to view the contents of a generated outgoing message. Viewing multiple messages is not supported.

### **Authorize**

Click to authorize, if you are provided authorization rights for an operation at the Messaging Branch Preferences level. Messages should be authorized before sending them.

### **HandOff**

Click if you need to hand-off a generated message to MCS to save the date in an ASCII format.

### **Details**

Click if you need to view the details of a generated outgoing message. Viewing details of multiple messages is not supported

### **On-line Auth**

Click to authorize online, if you are provided online authorization rights for an operation at the Messaging Branch Preferences level. Messages should be authorized before sending them.

### **Copy**

Click if you need to send a copy of an outgoing message to another customer involved in a contract. You will provide the following to options:

- Any–Select to implement the following changes:
  - Select media from an adjoining option list
  - Specify name of the recipient
  - Specify the location of the recipient
  - Specify the address of the recipient
- Original–Select to copy the message in the original form

### **Carry Forward**

Click if you need to Carry Forward an outgoing message which is on 'Hold' for subsequent days.

---

#### **Note**

Messages which have been Carried Forward can be put back on Hold.

---

### **BIP Advice**

Click if you need to generate advice in PDF format.

---

#### **Note**

- Advice ACST\_DETAILED as part of AC module.

- Only ACST\_DETAILED and Credit Instrument Liquidation Advices (i.e., DD and BC) as part of Branch Advice are supported in PDF format.

You can generate BIP advice messages for Branch advices by maintaining 'BRANCH\_ADV\_TYPE' as 'BIP'. Generation of these BIP advices is similar to 'Host' advices.

---

### Note

If an advice is not generated, then the system generates, spools, and moves it to the client work station.

---

## 8.2.2 Maintaining BIP Advice File Format

You can maintain BIP advice file format using BIP Advice File Format screen. You can invoke the 'BIP Advice File Format' screen by typing 'MSDADFTP' in the field at the top right corner of the Application tool bar and clicking on the adjoining arrow button. The screen is as shown below:

The screenshot shows a software window titled "BIP Advice File Format". Inside the window, there is a "New" button and a form titled "Advice File Format". The form contains four input fields, each with a red asterisk indicating it is required: "Branch Code \*", "Module \*", "Advice Message Type \*", and "Advice File Format \*". The "Advice File Format" field is a dropdown menu currently showing "PDF". At the bottom of the window, there is a dark blue footer area containing several fields: "Maker", "Checker", "Mod No", "Date Time:", "Record Status", and "Authorization Status". An "Exit" button is located in the bottom right corner of this footer area.

You can maintain the following parameters here:

### Branch Code

Specify branch code for which you need to maintain BIP advice file format, from the adjoining option list

### Module

Specify branch code for which you need to maintain BIP advice file format, from the adjoining option list

### Advice Message Type

Specify advice message type of the BIP advice file format, from the adjoining option list.

### Advice File Format

Select a valid file format in which you would prefer to generate the BIP message, from the adjoining drop-down list. This list displays the following:

- PDF
- Excel
- HTML
- RTF

### 8.2.3 Processing Outgoing Messages with PDE Trailer

System identifies outgoing messages with a PDE (Possible Duplicate Emission) trailer and parks it in the PDE queue. From the PDE queue you can opt to either release the message with/without the PDE trailer or reject the message. You can release or reject an outgoing message with a PDE Trailer using the PDE Detailed screen. You can invoke the 'PDE Detailed' screen by typing 'MSDETPDE' in the field at the top right corner of the Application tool bar and clicking on the adjoining arrow button.

The screenshot shows a window titled "PDE Detail" with the following fields and controls:

- ESN: [Text Input]
- Branch Code: [Text Input]
- User Reference: [Text Input]
- Reference Number: [Text Input]
- Document Number\*: [Text Input]
- Status\*: [Dropdown Menu]
- Message: [Large Text Area]
- Remark: [Text Input with speech bubble icon]
- Input By Date Time: [Text Input]
- Authorized By Date Time: [Text Input]
- Authorized: [Checkbox]
- Exit: [Button]

The following details of the message are displayed in the above screen:

- Branch Code
- Reference Number
- ESN
- DCN
- Remark
- Message

You need to capture the following information in the above screen:

#### **Status**

Select the status of the message from the drop-down list. The options available are:

- Release with PDE
- Release without PDE
- Reject

In order to view the details of the record click 'Detail' button. The details of the record are displayed in the 'PDE Detail' screen.

The screenshot shows a window titled "PDE Detail". It contains several input fields: "ESN", "Branch Code", "User Reference", "Reference Number", "Document Number\*", and "Status\*" (a dropdown menu). There is a large text area for "Message" and a smaller one for "Remark" with a speech bubble icon. At the bottom, there is a "Detail" button, a section for "Input By" and "Authorized By" (both with "Date Time" labels), a checkbox for "Authorized", and an "Exit" button.

The following details of the message are displayed:

- Module Id
- Reference Number
- User Ref No
- Message

### 8.2.3.1 Viewing Outgoing Messages with PDE Trailer

You can view all the PDE messages parked in the PDE queue using the 'PDE Summary' screen. You can invoke the PDE Summary screen by typing 'MSSETPDE' in the field at the top right corner of the Application tool bar and clicking on the adjoining arrow button.

The screen is as shown below:

Summary

Reference Number

Document Number

Remark

User Reference

Branch Code

Search Advanced Search Reset

Records per page 15 1 Of 1  Go

Reference Number | User Reference | Document Number | Running Number | ESN | Branch Code | Remark | Status |

Exit

In the above screen you can query for a record based on any of the following parameters:

- Reference Number
- User Reference
- Document Number
- Branch Code
- Remark

Based on the query, the following details of the record which match the query parameter are displayed:

- Reference Number
- User Reference
- Document Number
- Running Number
- ESN
- Branch Code
- Remarks
- Status

In order to view the details of each record select the record and click 'Detail' button. The details of the selected record are displayed in the 'PDE Detail' screen.

For more details on PDE validations on outgoing messages refer section 'Performing PDE Validations on SWIFT Messages' in 'Maintaining Messaging Branch Preferences' chapter of this User Manual

---

## 9. Retrieving an Archived Message

### 9.1 Introduction

Archival is the process of storing old messages for future retrieval. To recall, while defining messaging preferences for your branch you have also specified the number of days for which an outgoing message should be kept in the Outgoing Message Browser.

A message will be automatically archived after the number of days that you specified in the 'Messaging Branch Preferences' screen. You can choose to retrieve the outgoing messages that have been archived by invoking the 'Message History Retrieval Summary' screen.

### 9.2 Invoking Message History Retrieval Summary Screen

You can invoke the 'Message History Retrieval Summary' screen by typing 'MSSUNARC' in the field at the top right corner of the Application tool bar and clicking on the adjoining arrow button. The Unarchive Outgoing message screen is displayed.

The screenshot shows a web application window titled "Summary". At the top, there are six search filter fields: "Module", "Message Type", "Receiver", "Reference Number", "Media", and "Date". Each field has a small icon to its right. Below these fields are three buttons: "Search", "Advanced Search", and "Reset". Underneath the buttons is a pagination control showing "Records per page 15" and "1 Of 1". Below the pagination is a table header with columns: "Document Number", "Module", "Reference Number", "Message Type", "Media", "Receiver", and "Date". At the bottom left of the window is a "View Message" button, and at the bottom right is an "Exit" button.

In the above screen, you can base your queries on any or all of the following parameters and fetch records:

- Module
- Reference Number
- Message Type
- Media
- Receiver
- Date

Select any or all of the above parameters for a query and click 'Search' button. The records meeting the selected criteria are displayed.



System displays the following details pertaining to the fetched records:

- Module
- Reference Number
- Message Type
- Media
- Receiver
- Date

Click 'View Message' to view the archived message in the standard Oracle FLEXCUBE message viewer.

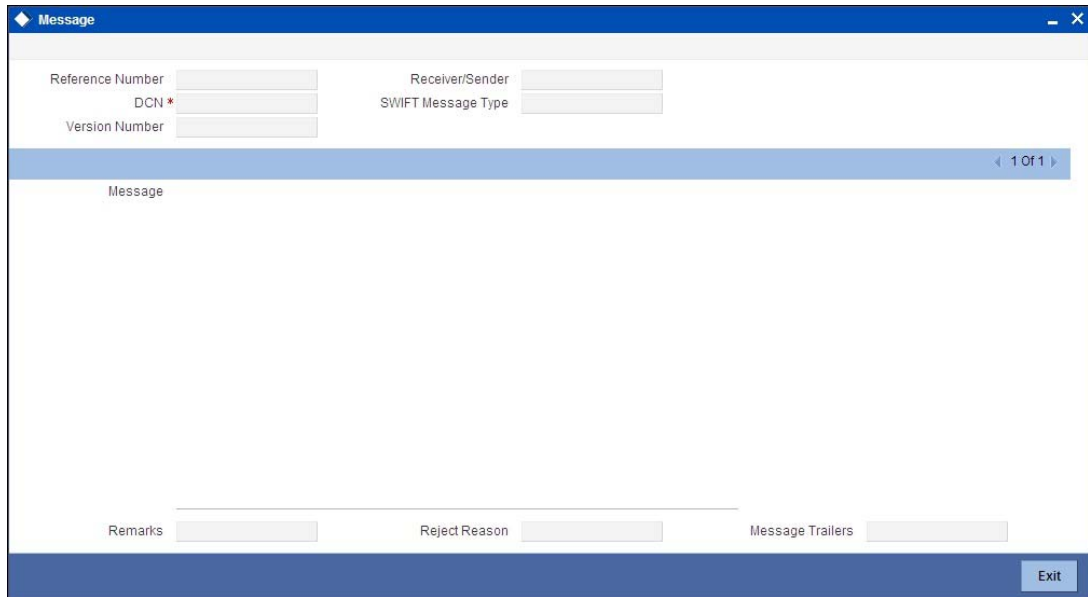

The screenshot shows a window titled "Message" with a blue header and a white body. The window contains several input fields for message details:

- Reference Number:
- Receiver/Sender:
- DCN \*:
- SWIFT Message Type:
- Version Number:

Below the input fields is a blue bar with a navigation arrow and the text "1 Of 1". The main area of the window is labeled "Message" and is currently empty. At the bottom of the window, there are three input fields: "Remarks", "Reject Reason", and "Message Trailers". A blue "Exit" button is located in the bottom right corner of the window.

Click 'Exit' or 'Cancel' to return to the Application Browser.

---

# 10. Processing Incoming Messages

## 10.1 Introduction

To recall, in the 'MCS Maintenance' screen, you have indicated the Media Control Systems that are connected to the node in which the database of your branch is installed. You have also specified the media that the MCS should handle. Besides, you have specified a hand-off directory into which all incoming messages transmitted through a specific media should be stored.

The final destination of an incoming message is the end user queue. These queues represent departments responsible for acting on the received messages.

## 10.2 Viewing Incoming Messages

All incoming messages that are intended for your bank will be handled based on the MCS specifications that you have maintained for your branch. You can choose to receive the incoming messages in the ASCII format from an MCS, and manually direct them to the appropriate queues, or indicate that the background process should automatically pickup incoming messages from an MCS and transfer them to the appropriate queues.

### 10.2.1 Background Processing of Incoming Messages

If you indicate that incoming messages for your branch should be processed in the background, messages will be routed to the relevant queues as and when they come in without manual intervention.

You can configure the background process to begin when the Beginning of Day process is run or you can invoke it at any time in the day. This screen (CSSJOBBER / CSSJMNTR) can also be used to check whether the background process is running for outgoing and incoming messages.

Messages that are transmitted by mail will have to be handled manually. Messages transmitted through media like Telex and S.W.I.F.T. will be automatically routed to the relevant queues. A unique reference number (DCN) is assigned to each incoming message.

Incoming messages, which have an error, will be moved to the error queue.

### 10.2.2 Manual Processing of Incoming Messages

You will have to manually process incoming messages if:

- the background message process is not running
- to route messages that cannot be routed to a user queue automatically

If the background process is not running, the messages that have come in to your bank will be stored in the incoming directory located on the node at which the database of your branch is installed. To recall, you have specified this directory in the 'MCS maintenance' screen. On invoking the Incoming Message Browser, you should upload all the messages from the directory on the node. All the incoming messages will be displayed in the Incoming Browser.

From the 'Incoming Message Browser' screen, you can receive messages that have come in through the MCS connected to the node in which the database of your branch is installed. You

can invoke the 'Incoming Message Browser' screen by typing 'MSSINBRW' in the field at the top right corner of the Application tool bar and clicking on the adjoining arrow button.

### 10.2.3 Features on Incoming Message Browser

From the Incoming Message Browser you can:

- upload incoming messages from the incoming directory on the node
- check Testwords for Telex messages
- authorize the Testword check for messages
- link an incoming message to a contract
- route the incoming messages to appropriate queues

You can query for the records based on any or all of the following:

- Branch
- Document Number
- Reference No
- Sender
- Media
- Swift Message Type
- Testword
- Auth Status
- Status
- Suppress Message
- Process Status

The following details of an incoming message will be displayed:

- Branch
- Document Number (DCN) assigned to the incoming message -- the DCN is the delivery control number used to identify the message. It is a 10-digit number prefixed with a letter of the English alphabet. The DCN ID is made up as follows:
  - ? 1-2 Characters -- Last two digits of the current year
  - ? 3-5 Characters -- Day of the year (Julian Date)
  - ? 6-10 Characters -- Sequential number starting from 00001 each day
- Reference No
- Sender- the name address and location of the sender of the message
- Media - the media through which the message was transmitted
- SWIFT Message Type of the message
- Customer Name – the name of the sender of the message
- Address 1–4 – the location of the sender of the message
- Location – the location of the sender of the message
- Testword (in case of a Telex message)
- Entry By
- Maker Date Stamp
- Repair Reason
- Running Number
- Generated Reference
- Queue in which the message is stored
- Auth Status
- Checker Date Stamp
- Checker ID
- Remarks
- Status
- Currency
- Amount
- Suppress Message
- External Reference
- Multi Credit Reference
- RTGS Network
- Process Status
- Modification Number
- PDE Flag
- Required Execution Date

You can set some of the above parameters to make a query. Specify the details in the respective fields and click 'Search' button to view the details.

Checking the testword for a telex message

Telex messages that come into your bank need to be checked for validity if you have specified so in the messaging branch preferences screen. This is done by entering a testword. The test word that you enter depends on the testword arrangement with the counterparty, the important aspects of the message like customer, date and currency.

If the testword you enter does not match the telex testword the message is registered as a defective message and put into the repair status.

### **External Reference Number**

This is a unique message identification number that will be used to identify an incoming message coming from an external system. This is defined as the ICN number. On upload of an incoming message into Oracle FLEXCUBE, this number, given by the external system, will be stored in Oracle FLEXCUBE and passed on to the contract generated as a result of the incoming message. If the incoming message results in an outgoing message, the ICN number will be linked to the outgoing message also.

This number will help you in creating a relationship between the incoming message, the resultant contract in Oracle FLEXCUBE, and the outgoing message, if any.

For instance, if an incoming MT103 results in an FT transaction, then ICN number of the incoming MT103 will be linked to the FT contract generated due to the upload of the incoming payment message.

If an Incoming message results in an outgoing contract (outgoing message), Oracle FLEXCUBE will store the External reference number (ICN Number) at the following levels.

- Incoming Message Level
- Contract Level (Resulted due to the Incoming message)
- Outgoing message (As a result of the above contract)

### **RTGS Network**

The service identifier of the RTGS network will be picked up from field 113 of block 3 header of the incoming message and displayed here.

For TARGET 2 clearing network, the service identifier specified for the network in the 'Clearing Networks' screen will be defaulted and displayed here.

### **Status**

You can filter the records based on the status. The drop-down list displays the following statuses:

- Unprocessed
- Processed
- Repair
- Suppressed
- Funding Exception
- Pending Cover Match
- Failed Verification
- Pending Authorization
- Pending liquidation
- Pending Auth Receipt

If the Bill Liquidation is failed for the trade related MT202 message, the status will be updated as 'L (Pending liquidation)'.

You can list all the trade related MT202 which are failed during Bill Liquidation by filtering by 'Status' as 'L'. On successful processing of Trade Related MT202, the 'Generated Ref No' is displayed with the Bill Contract Ref No in the 'Incoming Message Browser' screen.

## 10.2.4 Linking Guarantee Issuance Contract to an Incoming Message

You can link guarantee issuance contract to an incoming MT760 message in the Incoming Message Browser screen.

While linking the incoming MT760 message to a Guarantee contract, the system validates:

- if the reference in the Tag20 of the incoming MT760 message is same as the reference captured against the applicant bank in the guarantee contract.
- value in the Tag 23 of the incoming MT760 message linked to the contract is 'Request' for the contracts where the product type is 'G'.
- value in the Tag 23 of the incoming MT760 message linked to the contract is 'Issue' when the product type of the Guarantee contract is 'A'

An error message is displayed if the above validations fail during linking of an incoming MT760 message to guarantee contract.

After linking, the incoming MT760 message will be displayed in the 'All Messages' sub-system of the linked Guarantee contract.

## 10.2.5 Operations that you can perform on an Incoming Message

<p><b>View Delete</b></p>	<p><b>Viewing and deleting the contents of a message</b></p> <ol style="list-style-type: none"> <li>1. To view the contents of an incoming message:</li> <li>2. Highlight the message you want to view and</li> <li>3. Click the 'View Message' button on the Browser</li> <li>4. The contents of the message will be displayed in a separate screen.</li> </ol>
<p><b>Print</b></p>	<p><b>Printing a message</b></p> <p>You can choose to print the details of an incoming message. To print the details of an incoming message,</p> <ol style="list-style-type: none"> <li>1. Highlight the message you want to print and</li> <li>2. Click the 'Print button' on the Browser</li> </ol> <p>When you select the print option, you will be prompted to indicate whether you want to spool or directly print the message. You can also view the SWIFT tag description</p>
<p><b>Change Branch</b></p>	<p><b>Changing the Branch of the message</b></p> <ol style="list-style-type: none"> <li>1. Select the message for which Branch has to be changed</li> <li>2. Click on "Change Branch" button.</li> </ol> <p>The details of the message will be displayed with only the Branch field enabled. Choose the new branch from the list of values provided and save the message.</p>
<p><b>TW Auth</b></p>	<p><b>Authorizing a Testword</b></p> <p>A telex message for which you entered a testword should be authorized before it can be routed to a user queue (if you have specified so in the Branch Preferences screen).</p> <p>To authorize a test word that was entered for a telex message, click the 'TW Auth' button from the Browser on this screen.</p> <p>During the authorization of a testword the authorizer will be required to re-enter the testword.</p>

<p><b>Move To Queue</b></p>	<p><b>Routing a message to a queue</b></p> <p>After you have made the checks that are necessary for the media through which a message is transmitted you can route the message to a user queue. To change the queue in which an incoming message should be stored:</p> <ol style="list-style-type: none"> <li>1. Select the message</li> <li>2. Click the 'Move to Queue' button</li> <li>3. Select a queue from the adjoining option list</li> </ol> <p>The message will be automatically moved to the queue that you specify. The final destination of an incoming message is the end-user queue. These queues represent departments or printers responsible for acting on the received messages. Once a message is lodged into an end user queue, it can be viewed on-screen or printed by the users who have access to the queue.</p> <p>You can move messages from one end user queue to another as well.</p> <p>For a message that was transmitted through Telex, you should enter the testword and have it authorized before you can route it to the relevant end user queue.</p>
<p><b>Link Contract</b></p>	<p><b>Linking the message to a contract</b></p> <p>In the browser, select the message with which you want to associate a contract and click on the 'Link Contract' button. The Reference Number option-list is enabled for the selected message. You can select the appropriate contract from the list. The message will be subsequently associated with the contract selected here.</p>
<p><b>Upload</b></p>	<p><b>Uploading incoming messages</b></p> <p>If the background process for incoming messages is not running you will have to upload the messages that have come into your bank from the incoming directory on the node to which your branch is connected.</p> <p>To upload messages from the incoming directory (specified in the MCS maintenance screen) click the 'Upload' button. All messages that were stored in the Incoming Directory will be uploaded to Oracle FLEXCUBE and displayed in the Incoming Message Browser.</p>
<p><b>Edit</b></p>	<p><b>Editing the Incoming Message</b></p> <p>Click 'Edit Message' button if you wish to make changes to the SWIFT message, especially the messages marked for repair. This is explained in the next Section.</p>



<p><b>Authorize</b></p>	<p><b>Authorizing the Incoming Message</b></p> <p>Use 'Authorize' button to authorize the message. All the amendments made to a SWIFT payment message have to be authorized by a user with appropriate authorization rights. At the time of authorizing, Oracle FLEXCUBE will display the earlier version of the SWIFT payment message along with the amended version, in the same window.</p> <p>A list of all the errors due to which the message was marked for repair is also displayed. The authorizer can view all the errors and also verify the changes that were made to correct them. After verification, if all the details are found to be appropriate, the message is authorized.</p> <p>Oracle FLEXCUBE maintains a detailed audit log of all amended SWIFT Payment Messages. The following details are captured for each authorized message:</p> <ul style="list-style-type: none"> <li>• User ID of the person who authorized the amendments</li> <li>• Date and time of authorization</li> </ul> <p>At any point during the verification and authorization process, the authorizer can choose to cancel the entire operation without changing the status of the message.</p>
<p><b>Force</b></p>	<p><b>Force Releasing Messages</b></p> <p>Use 'Force Release' button to forcibly release all Payment Message Transactions with 'Funding Exception' status and insufficient funds. In other words, the system will post the required accounting entries for such transactions regardless of insufficient funds in the accounts. However, an override will be displayed. The system will also maintain a detailed audit trail for such transactions. A user with appropriate rights can perform this function.</p>

<b>Suppress</b>	<p><b>Suppressing the Incoming Message</b></p> <p>To suppress a message, click 'Suppress' button in the Incoming Browser and invoke the 'Suppress Message' screen. The following options are available to suppress a Payment Message:</p> <ul style="list-style-type: none"> <li>• Suppress Message Generation</li> <li>• Suppress Full</li> <li>• No Suppress</li> </ul> <p><b>Specifying the 'Suppress Message Generation' option</b></p> <p>If you select this option, Oracle FLEXCUBE will stop the generation of the Payment Message. However, the system will post the necessary accounting entries for the messages being suppressed.</p> <p><b>Indicating the 'Suppress Full' option</b></p> <p>If you select the full suppress option for a message, the system will not post the related accounting entries. Advice generation will also be stopped. In other words, the system will not pick up the Payment Message for any further processing.</p> <p><b>Specifying the 'No Suppress' option</b></p> <p>A message marked with the 'No Suppress' option will be processed like any other normal Incoming SWIFT Payment Message.</p> <p><b>Specifying the remarks for a suppressed message</b></p> <p>You can specify the reason for suppressing a Payment Message in the 'Remarks' field.</p>
-----------------	--

Click 'Exit' or 'Cancel' to return to the Application Browser.

## 10.2.6 Viewing Details of Incoming Message

You can view an incoming message in the Incoming Message Summary screen by selecting the message and clicking 'Details' button.

The screenshot shows a window titled 'Message' with the following fields and sections:

- Document Number\***: Text input field.
- Reference Number**: Text input field with a search icon.
- Sender**: Text input field.
- Media**: Text input field with a search icon.
- SWIFT Message Type**: Text input field with a search icon.
- Queue**: Text input field with a search icon.
- Operation**: Dropdown menu.
- Status**: Dropdown menu.
- Currency**: Text input field.
- Amount**: Text input field.
- Value Date**: Text input field.
- External Reference**: Text input field.
- Multi Credit Reference**: Text input field.
- Branch**: Text input field with a search icon.
- Media Control System**: Text input field.
- Node**: Text input field.
- Test Word**: Text input field.
- Repair Reason**: Text input field with a search icon.
- Required Execution Date**: Text input field.
- Customer Name**: Text input field.
- Address**: Text input field.
- Address 2**: Text input field.
- Address 3**: Text input field.
- Address 4**: Text input field.
- Location**: Text input field.
- Process Status**: Dropdown menu.
- PDE Flag**: Text input field.
- Suppress Details**: Section containing:
  - Remarks**: Text input field with a search icon.
  - Suppress Options**: Dropdown menu.
- Checker Date Stamp**: Text input field.
- Checker Id**: Text input field.
- Mod Number**: Text input field.
- Entry By**: Text input field.
- Maker Stamp**: Text input field.
- Cover Match Status**: Text input field.
- Suppress Status**: Text input field.
- Funding Exception Status**: Text input field.
- Authorization Status**: Text input field with a checkbox.

Buttons: **Ok** and **Exit**.

The following details regarding the incoming message are displayed in the above screen:

- DCN

- Reference Number
- Sender
- Media
- Swift Message Type
- Queue
- Operation
- Status
- Currency
- Amount
- Value Date
- External Reference Number
- Multi Credit Reference Number
- Branch
- Media Control System
- Node
- Test Word
- Repair Reason
- Name
- Address
- Location
- Process
- PDE Flag
- Suppress Options
- Remarks
- Auth By
- Entry By
- Mod No
- Checker Date Stamp
- Maker Date Stamp
- Suppress Status
- Funding Exception Status
- Cover Match Status
- Authorization Status

### **10.2.7 Editing Incoming Message**

An incoming message can be edited by invoking the 'Edit' function in the Incoming Messages Browser. On pressing the 'Edit Message' button, the message is displayed in edit mode. Only a user with requisite rights for editing can edit an incoming message.

The screen is as shown below:

The screenshot shows the 'Edit Message' application window. It features a header section with fields for 'Reference No', 'Sender', 'SWIFT Message Type', 'Current Version', 'Previous Version', 'Mod Number', and a 'Remove Trailer' checkbox. The main area is divided into two panes: 'New Message' and 'Old Message'. Each pane contains a table with columns for 'Fields \* Tag', 'Field Name', and 'Field Value'. Below these panes are fields for 'Message Trailer', 'Remarks', and 'Reject Reason'. At the bottom, there is a 'Repair Reason' table with columns for 'Status', 'Message Status', 'Latest Version Number', and 'Repair Parameters'. The window concludes with a row of buttons: 'Reject', 'Save', 'Authorize', and 'Exit'.

If editing is possible for the user, the message is displayed and is available for amendment. The list of fields, which can be modified are maintained through back-end database tables appropriately during implementation of Oracle FLEXCUBE. Most typically, fields like amount, currency would be maintained as non-modifiable whereas fields such as value date could be maintained as modifiable. Based on the maintenance in these tables, the appropriate fields are enabled for amendment.

On saving the amendment of the message, a new version is created and must be authorized. The screen shown above displays two versions of an incoming message. If the verifier needs to reject the change for any reason the same can be mentioned in the 'Reject Reason' field.

---

#### Note

In the case of incoming messages with a PDE trailer, the 'PDE Flag' check box in the 'Incoming Message Browser' screen will be checked. In the 'Edit Message' screen, check 'Remove Trailer' option to remove the PDE trailer (message contains the text {'PDE:'}) and save the message.

---

## 10.3 Viewing SWIFT Notification Messages

SWIFT provides the following two types of notification messages to Oracle FLEXCUBE:

- ACK/NACK acknowledgement messages indicating whether the message has been successfully delivered to SWIFTNet FIN service, from where it gets forwarded to the receiving system
- Delivery notification messages indicating whether the message was successfully delivered to the receiving system

You can access these notifications messages using 'SWIFT Message Notification Browser' screen. You can invoke this screen by screen by typing 'MSDNOTIB' in the field at the top right corner of the Application tool bar and clicking on the adjoining arrow button.

The screen is as shown below:

In the above screen, you can base your queries on any or all of the following parameters and fetch records:

- Document Number
- Sender
- Swift Message Type
- Process Status
- Auth Status
- User Reference
- Reference Number

Select any or all of the above parameters for a query and click 'Search' button. The records meeting the selected criteria are displayed.

System displays the following details pertaining to the fetched records:

- Branch
- Document Number
- Sender
- Swift Message Type
- Branch Date
- Maker ID
- Maker Date
- Repair Reason

- Running Number
- Process Status
- Auth Status
- Checker DT Stamp
- Checker ID
- Message Reference
- Receiver
- User Reference
- Mod Number
- reference Number

A back-ground job running on this browser updates the outgoing browser with the ACK/NAK and the delivery status of the message. The sender MUR from SWIFT is used to match the corresponding outgoing browser record.

## 10.4 Maintaining MT Task Details

Using the 'STP Message Maintenance Details' screen, you can maintain the basis for creation of MT tasks for SWIFT message. You can invoke this screen by typing 'MSDSTPSC' in the field at the top right corner of the Application tool bar and clicking the adjoining arrow button.

In this screen, you can specify the following details:

### **Branch Code**

Specify the branch code for which the task creation has to be made. This adjoining option list displays all valid branches maintained in the system. You can choose the appropriate one.

### **Branch Name**

On selecting the branch code, the system defaults the branch name of the bank.

**SWIFT Msg Type**

Specify the type of the SWIFT Message here. This adjoining option list displays all the SWIFT messages that are maintained in the system. You can choose the appropriate one.

**Direct**

Check this option to indicate that a MT task/business task should be created for the SWIFT message without subjecting it to the STP process. This is applicable for STP messages.

If this option is checked for Non-STP messages, then a MT task will be created for the Non-STP messages.

**STP Error Flag**

Check this option to indicate that a MT task/business task should be created when the STP process fails. This is applicable only for the STP Messages.

**STP Hold Flag**

Check this box to indicate that a MT task/business task should be created for a contract that is put on hold during successful STP processing.

This option is applicable only for the STP messages.

**Unauthorized**

Check this box to indicate that a MT task/business task should be created for a contract that is unauthorised during successful STP processing.

This option is applicable only for the STP messages.

**Effective Date**

Specify the date from which the STP message maintenance becomes effective. Effective date should be equal to or greater than the application date.

**Task Type**

Select the task type from the adjoining drop-down list. This list displays the following values:

- MT Task
- Business Task

# 11. Defining Free Format Messages

## 11.1 Introduction

In the course of your daily banking operations you may want to generate messages that are not automatically generated by the system or you may have to communicate a message that is very specific to a customer. You can enter the details of such messages in the form of a free format message.

The details of a Free Format Message can be entered in the Free Format Message Maintenance screen. In this screen some of the details you can indicate are:

- The format of the message
- The recipient of the message
- The media through which the message should be transmitted
- The address and location to which the Free Format Message should be sent

## 11.2 Invoking Free Format Message Maintenance Screen

You can also invoke the Free Format Message screen by typing 'MSDFFTMN' in the field at the top right corner of the Application tool bar and clicking on the adjoining arrow button. The screen is shown below:

The screenshot shows the 'Free Format Message Maintenance' window. It includes a 'Save' button at the top left. The main area contains several input fields: 'Document Number', 'Module \*' (set to 'LS'), 'Customer \*', 'Media \*', 'Location Movement', 'Node', 'Date' (set to '12-JAN-2011'), 'External Reference No', 'Name \*', 'Address \*', 'Form \*' (set to 'ADV'), 'Copies' (set to '1'), 'Hold' checkbox, 'Test Word Required' checkbox, 'Contract Reference \*', 'TAGS', and 'Import File'. There is an 'Import' button with a 'Server' radio button selected. At the bottom, there is a 'Message' field and a 'Fields' section with columns for 'Maker', 'Date Time', 'Mod No', 'Record Status', and 'Authorization Status'. A 'Cancel' button is located at the bottom right.

## 11.3 Features of Free Format Message Screen

You can specify the following details on this screen.

### Document Number

System generates the document number on save.

### Module

Select the module from the drop-down menu, for which you are entering the details in this screen.



**Customer**

Select the code of the customer to whom the message is addressed, from the option list. If the recipient is not a customer of your bank, then specify his/her name in this field.

**Media**

You can indicate the media through which the Free Format Message should be transmitted. The media through which you can channel a Free Format Message depends on the media types that you have maintained for your branch in the 'Media Maintenance' screen. You can choose a media code from the option list that is available.

**Location Movement**

You should also specify the location of the address. To recall, the location that you specify for an address is the unique identifier between the other addresses of the customer for a given media.

The address of the customer will be automatically displayed based on the customer-location-media combination that you indicate if it has already been maintained in the system.

**Node**

You can indicate the node from where this Free Format Message has to be generated.

**External Reference Number**

The system displays external reference number on save.

**Name**

In the case of a walk-in customer, enter the name of the customer to whom the message is to be addressed. If the recipient of the message is a customer of your bank, the customer's name will be automatically displayed when you indicate the customer's CIF number in the "Customer" field.

**Address**

If the recipient of the message is a customer of your bank, the customer's address will be automatically displayed based on the Customer-Media-Location combination that you have specified.

You will be required to enter the address in the case of a Walk-in customer. The format of the address depends on the media through which the Free Format Message is transmitted.

If the address is for the media type Mail, you can enter the customer's address in the four rows under this field. Each line that you enter can contain a maximum of 35 characters.

If the media of transmission is Telex, the address should be expressed numerically.

If you are defining a SWIFT address, the address should be of eight or eleven alphanumeric characters.

**Form**

If the message to be sent is in the form of a template, you can choose the template from the option list.

**Hold**

Messages that are put on hold are temporarily stopped from being generated. If you have indicated that messages should be generated in the background, the Free Format Message that you have defined will be immediately sent when you save the record. If for some reason you do not want to immediately send the message, you can place it on hold. In this case, the message will appear in the Outgoing Message Browser, but will be in the hold status. You will have to release the message before you generate it from the Outgoing Browser.

**Copies**

Enter the number of copies of the Free Format Message that should be sent to the customer at the time it is generated.

If you indicate that more than one copy should be sent to a location, the first message will be the original and the others will be marked as 'copy'.

**Test Word Required**

Indicate whether a test word needs to be inserted the telex message manually before it is generated from your branch.

**Contract Reference**

You can indicate the code assigned to the customer who is the recipient of the message. This is the code that you assigned to the customer in the Customer Information File (CIF). This option list displays all the contract reference number for those branches for which you have access right.

The following details are displayed on the screen:

- Reference Number
- Date
- Tags

**11.3.1 Entering Details of a Free Format Message**

You can enter the details of a Free Format Message either by:

- Using the format editor on the screen, or
- Importing the format from an ASCII file. This can be located either on the server or the client.

**Template ID**

Select template id from the option list.

Click 'P' button to populate the template details into field 79 by resolving the substitution variables. You can modify the fields under Tag 79. However, the substitution variables are already resolved and defaulted. While modifying the message, you should specify the values

directly and not the substitution variables again. System formats the amount and date based on default format at the application level.

### 11.3.2 Entering an Advice Format using Format Editor

To enter a format using the format editor, click free format text icon positioned next to the text of the message. In the note pad that is invoked you can actually tailor an advice to suit your requirements. Keywords to format the advice (similar to what is used in the Advice Format Maintenance) can be used here too in order to get the desired format. The following table contains a comprehensive list of the key words that can be used in the format editor.

Keyword	Significance
#NL	Indicates the number of lines that should be contained in a page when the message is printed
#NC	Indicates the number of columns that should be contained in a page when the message is printed
#RH	Indicates the start of the Report Header section
#PH	Indicates the beginning of the Header for a page
#EH	Indicates both the end of the Header section of the report or the end of Header section of a page
#RF	Indicates the start of the Report Footer section
#PF	Indicates the start of the Footer of a page
#EF	Indicates both the end of the Footer of a report or page
#B	Indicates the start of the body of the message
#EB	Indicates the end of the body of the message
#CL	Indicates that you can collapse a line

#EC	Indicates the end of a line that you have collapsed
#LOOP	Indicates the beginning of a loop
#END- LOOP	Indicates the end of a loop
#IF	Indicates a Conditional section
#ANDIF	Indicates a Conditional section
#ORIF	Indicates a Conditional section
#ENDIF	Indicates the end of a Conditional section

### **11.3.3 Importing Advice Format from an ASCII File on the Server**

The server indicates the machine on which the database of your bank is installed. To import a format from an ASCII file on the server:

- Select the radio button against 'Server'.
- Specify the full path to the file on the server which contains the format you want to import.
- Thereafter, click 'Import' button.

The file containing the format of the message will be displayed on the screen.

### **11.3.4 Importing Advice Format from ASCII File on Client**

Client refers to your own machine. To import a format from an ASCII file on the client:

- Click against the field marked Client,
- Specify the full path to the file on the client which contains the format you want to import
- Thereafter, click 'Import' button.

The file containing the format of the message will be displayed on the screen.

### **11.3.5 Sending Free Format Message**

A Free Format Message will be sent depending on your specifications in the 'Background Process' screen.

- If the background process is running, a free format text that you define will be immediately sent at the time you save the record.
- If the background process is not running, the Free Format Message that you have defined will be displayed in the Outgoing Message browser from where you can process as you would any other outgoing message.

### **11.3.6 Saving Record**

After you have made the mandatory entries, save the record. A free format record that you have defined should be authorized by a user bearing a different login ID, before the End of Day (EOD) process is run. Click 'Exit' or 'Cancel' to return to the Application Browser.

### 11.3.7 Viewing SWIFT Messages

You can view the SWIFT messages by clicking the 'SWIFT Messages' tab. The screen will be displayed as follows.

Free Format Message Maintenance

Save

Document Number

Module \* LS

Customer \*

Media \*

Location Movement

Node

Date 12-JAN-2011

External Reference No

Name \*

Address \*

Form \* ADV

Copies 1

Hold

Test Word Required

Contract Reference \*

TAGS

Import File

Import

Server

Message SWIFT Message Details Free Format Text

SWIFT Message Details

SWIFT Message Type 199

Fields

Maker Date Time: Mod No

Checker Date Time: Record Status

Authorization Status

Cancel

### 11.4 Maintaining Common Group Messages

You can maintain common messages that need to be sent to a group, in the 'Common Group Message Maintenance' screen. You can invoke the 'Common Group Message Maintenance'

screen by typing 'MSDCOMMS' in the field at the top right corner of the Application tool bar and clicking the adjoining arrow button.

The screenshot shows the 'Common Group Message Maintenance' application window. The window title is 'Common Group Message Maintenance'. The interface includes a top toolbar with 'New' and 'Enter Query' buttons. The main area contains a form with the following fields and controls:

- Customer: Text input field
- Reference Number: Text input field with a red asterisk
- Media: Text input field containing 'SWIFT'
- Location: Text input field
- Node: Text input field
- Date: Text input field
- Swift Message Type: Dropdown menu set to 'Incoming'
- Name: Text input field
- Address: Text input field
- Address 2: Text input field
- Address 3: Text input field
- Address 4: Text input field
- Form: Text input field
- Number of Copies: Text input field containing '1'
- Hold: Checkbox
- Reference Number for Query: Text input field

Below the form is an 'Import File' section with an 'Import' button and a 'Server' icon. The bottom of the window has a 'Fields' section with labels for Maker, Checker, Date Time, Mod No, Record Status, and Authorization Status, along with an 'Exit' button.

You can specify the following details in this screen:

### Customer

Select the code of the customer to whom the message is addressed, from the option list.

### Media

The media through which the common group message is transmitted is displayed here. 'SWIFT' is displayed, by default.

### Location

Specify the location of the address. The location of an address is the unique identifier between the other addresses of the customer for a given media.

### Node

Select the node at which the database of your branch is installed, from the option list provided.

### Name

Specify the name of the customer to whom the message is to be addressed. If the recipient of the message is a customer of your bank, the customer's name will be automatically displayed when you specify the customer code.

### Address 1-4

If the recipient of the message is a customer of your bank, the address gets automatically displayed based on the Customer-Media-Location combination that you have specified.

You need to specify the address in case of a walk-in customer.

**Form**

Select a template from the option list, if you wish to send the message in the form of a template.

**SWIFT Message Type**

Specify the type of the SWIFT message to be sent to the customer from the adjoining option list.

**Number of Copies**

Specify the number of copies of the message that should be sent to the customer at the time it is generated.

**Response To**

Select the type of the previous SWIFT message, in response to which the common group message is being sent. The following options are provided in the drop-down list:

- Incoming
- Outgoing

**Reference Number for Query**

When a common group message is sent, the reference number specified here will help to query and fetch the original message date and MT type from the Incoming/Outgoing Browser, depending on the value of 'Response To'.

**Hold**

Check this box to indicate that you want to keep the generation of the message on hold. Messages that are put on hold are temporarily stopped from being generated. The message will have to be released before it can be generated.

**Import File**

Specify the full path of the file on the server which contains the format you want to import.

**Server**

Select this option to import a format from an ASCII file on the server. The server indicates the machine on which the database of your bank is installed.

The following fields are displayed on this screen:

**Reference number**

This is the system generated unique reference number for the message, called DCN.

**Date**

The Date defaulted will be the system date.

**71B – Details of Charges**

Specify charge details for the specified message type from the adjoining option list.

The following options are available for MT n90 and MT n91 messages, if you have selected Category 1 or Category 2 message types:

Code	Description	Reason
AMND	Amendment	Payment order was changed based on a request to do so from the (original) sending bank or as a result of receiving amended information from the (original) sending bank.
CANF	Cancellation Fee	Used when fees are assessed for cancellation of a payment.

CLEF	Clearing Fee	Used when fees are assessed for standard processing of financial institution type transfers (Category 2 MT payments).
INVS	Investigation	Used when charges are being assessed for investigation or request for information required to complete payment processing.
NSTP	Non STP charge	Charge for a payment that required an intervention during processing.
OURC	OUR charging option used	Claim is being submitted in response to receiving a customer payment (Category 1 MT payment) with OUR in field 71A Details of Charges.

### Template ID

Select template id from the option list. On clicking 'P' button, the template details are defaulted into field 79 by resolving the substitution variables. You can modify the fields under Tag 79. While modifying the message, you have to specify the values directly and not the substitution variables again.

Click 'Import' button to import the file and display the format of the message on the screen.

Save the record after specifying the mandatory details and click 'Exit' or 'Cancel' button to return to the Application Browser

## 11.5 Maintaining SWIFT FFT Template

System has the facility to create SWIFT templates for free format messages with the help of resolver for predefined variable fields (for example; amount, applicant/beneficiary name, tenor, maturity etc). This helps avoiding predation of message which are repetitive in nature for example bill acceptance message, avilment confirmation or payment tracers etc. A dictionary of field resolvers is available in Oracle FLEXCUBE. You can create template as and when required with the combination of hard coated text and the field resolvers.

You can define templates for Free Format Messages which contains Template id, Language code and Free Format Text (Only for MT499 and MT799) using the 'Swift FFT Template



screen Maintenance' screen. You can invoke this screen by typing 'MSDFFTMP' in the field at the top right corner of the Application tool bar and clicking the adjoining arrow button.

The screenshot shows the 'FFT Template Maintenance' application window. The window has a title bar with a diamond icon and the text 'FFT Template Maintenance'. Below the title bar is a toolbar with a 'New' button and an 'Enter Query' button. The main content area is titled 'FFT Details' and contains the following fields:

- Template Id \* (text input)
- Language Code \* (text input)
- Free Format Text (text input)
- SWIFT Message Type (dropdown menu showing 'MT499')

The bottom of the window has a dark blue footer area with the following labels:

- Maker
- Checker
- Mod No
- Date Time:
- Date Time:
- Record Status
- Authorization Status

An 'Exit' button is located in the bottom right corner of the footer area.

Specify the following details:

### Template ID

Specify the template id.

### Language Code

Specify a valid language code. The adjoining option list displays all the valid language code maintained in the system. You can choose the appropriate one.

### Free Format Text

Specify the Substitution Variables. You can identify these variables by prefixing them with '@' or by some other special character.

### Swift Message Type

Select the Swift Message type from the drop-down list. You have the following options:

- MT799
- MT499
- MT999

Following are the substitute variables:

<b>Message</b>	<b>Substitution Variables</b>	<b>Description</b>
MT799	LC_AMOUNT	LC Amount
	LC_CCY	LC Currency
	LC_LIABILITY	LC Outstanding Amount
	ISSUE_DATE	LC Issue Date
	LC_TENOR	LC Tenor
	EXPIRY_DATE	LC Expiry Date
	EXPIRY_PLACE	LC Expiry Place
	CLOSURE_DATE	LC Closure Date
	LC_CONTRACT_REF	LC Contract Reference Number
	LC_USER_REF	LC User Reference Number
	SHIPMENT_FROM	Shipment From
	SHIPMENT_TO	Shipment To
	PORT_LOADING	Port of Loading
	PORT_DISCHARGE	Port of Discharge
	CREDIT_AVL_WITH	Credit Available with
	INCO_TERM	Inco Term
	APPLICABLE_RULE	Applicable Rule
	BENEFICIARY	Beneficiary
	APPLICANT	Applicant
	REIMB_BANK	Reimbursing Bank
OLD_BEN	Old Beneficiary before the amendment	
OLD_REM	Old Reimbursing bank before the amendment	

<b>Message</b>	<b>Substitution Variables</b>	<b>Description</b>
MT499	OLD_ADV	Old Advising bank before the amendment
	APP_BANK	Applicant Bank
	CLAIM_BANK	Claiming Bank
	CNF_BANK	Confirming Bank
	ADV_BANK	Advising Bank
	ADV_THRU_BANK	Advice Thru Bank
	LATEST_SHIPMENT_DATE	Latest Shipment Date
	SHIPMENT_PERIOD	Shipment Period
	CONFIRMED_AMT	Confirmed LC Amount
	UNCONFIRMED_AMT	Unconfirmed LC Amount
	AVAILED_AMOUNT	Availed Amount
	REB_UT_AMOUNT	Reimbursement Amount undertaken
	REB_NUT_AMOUNT	Reimbursement Amount not undertaken
	DRAWER	Drawer
	DRAWEE	Drawee
	FORFAIT_HOUSE	Forfaiting house / bank
	REMIT_BANK	Remitting Bank
	COL_BANK	Collecting Bank
	DISC_BANK	Discounting Bank
	NEGO_BANK	Negotiating Bank
	TRF_BANK	Transferee Bank
	BILL_AMT	Bill Amount
	BILL_CCY	Bill Currency
	OS_AMOUNT	Bill Outstanding amount
	VALUE_DATE	Bill Value date
	TRANSACTION_DATE	Bill transactions date
	TRANSIT_DAYS	Transit days
	BILL_TENOR	Bill Tenor
BILL_MATURITY	Bill Maturity date	

<b>Message</b>	<b>Substitution Variables</b>	<b>Description</b>
	LIQUIDATION_DATE	Bill Liquidation date
	INCO_TERM	Inco Term
	OUR_LC_REF	Our LC Ref No
	THEIR_LC_REF	Their LC Ref No
	BC_CONTRACT_REF	BC Contract Reference Number
	BC_USER_REF	BC User Reference Number
	BROK_DETAILS	Broker, Brokerage and Brokerage Currency
	SHIPMENT_FROM	Shipment From
	SHIPMENT_TO	Shipment To

<b>Message</b>	<b>Substitution Variables</b>	<b>Description</b>
MT999	LC_CCY	LC Currency
	LC_LIABILITY	LC Outstanding Amount
	ISSUE_DATE	LC Issue Date
	LC_TENOR	LC Tenor
	EXPIRY_DATE	LC Expiry Date
	EXPIRY_PLACE	LC Expiry Place
	CLOSURE_DATE	LC Closure Date
	LC_CONTRACT_REF	LC Contract Reference Number
	LC_USER_REF	LC User Reference Number
	SHIPMENT_FROM	Shipment From
	SHIPMENT_TO	Shipment To
	PORT_LOADING	Port of Loading
	PORT_DISCHARGE	Port of Discharge
	CREDIT_AVL_WITH	Credit Available with
	INCO_TERM	Inco Term
	APPLICABLE_RULE	Applicable Rule
	BENEFICIARY	Beneficiary
	APPLICANT	Applicant
	REIMB_BANK	Reimbursing Bank
	OLD_BEN	Old Beneficiary before the amendment
	OLD_REM	Old Reimbursing bank before the amendment
	OLD_ADV	Old Advising bank before the amendment
	APP_BANK	Applicant Bank
	CLAIM_BANK	Claiming Bank
	CNF_BANK	Confirming Bank
	ADV_BANK	Advising Bank
	ADV_THRU_BANK	Advice Thru Bank
LATEST_SHIPMENT_DATE	Latest Shipment Date	
SHIPMENT_PERIOD	Shipment Period	

Message	Substitution Variables	Description
	CONFIRMED_AMT	Confirmed LC Amount
	UNCONFIRMED_AMT	Unconfirmed LC Amount
	AVAILED_AMOUNT	Availed Amount
	REB_UT_AMOUNT	Reimbursement Amount undertaken
	REB_NUT_AMOUNT	Reimbursement Amount not undertaken
	DRAWER	Drawer
	DRAWEE	Drawee
	FORFAIT_HOUSE	Forfaiting house / bank
	REMIT_BANK	Remitting Bank
	COL_BANK	Collecting Bank
	DISC_BANK	Discounting Bank
	NEGO_BANK	Negotiating Bank
	TRF_BANK	Transferee Bank
	BILL_AMT	Bill Amount
	BILL_CCY	Bill Currency
	OS_AMOUNT	Bill Outstanding amount
	VALUE_DATE	Bill Value date
	TRANSACTION_DATE	Bill transactions date
	TRANSIT_DAYS	Transit days
	BILL_TENOR	Bill Tenor
	BILL_MATURITY	Bill Maturity date
	LIQUIDATION_DATE	Bill Liquidation date
	INCO_TERM	Inco Term
	OUR_LC_REF	Our LC Ref No
	THEIR_LC_REF	Their LC Ref No
	BC_CONTRACT_REF	BC Contract Reference Number
	BC_USER_REF	BC User Reference Number
	BROK_DETAILS	Broker, Brokerage and Brokerage Currency
	SHIPMENT_FROM	Shipment From
	SHIPMENT_TO	Shipment To

In case of a Bill contract under an LC, the system resolves all tags applicable to MT799 and MT499. In such cases, the tags related to Bills are resolved based on the corresponding Bill contract. Similarly, the tags related to LC are resolved based on the LC contract which is linked to the Bill contract.

# 12. Making Query

## 12.1 Introduction

When you are in the Outgoing or Incoming Message Browser, all the messages that were transmitted from and received at your branch are displayed. This may amount to hundreds of messages. To avoid wading through this mass of data, you can make a query to obtain information that is relevant to you at a particular time.

For example, you may want to obtain information on the messages that were sent to just two customers, on a specific date. Or you may want to see all outgoing messages across modules, sent during a specific period. The Advanced Search function makes this possible for you.

To make an advanced search, click 'Advanced Search' button either from the Outgoing or Incoming Browser as the case may be. The 'Advanced Summary' screen is displayed.

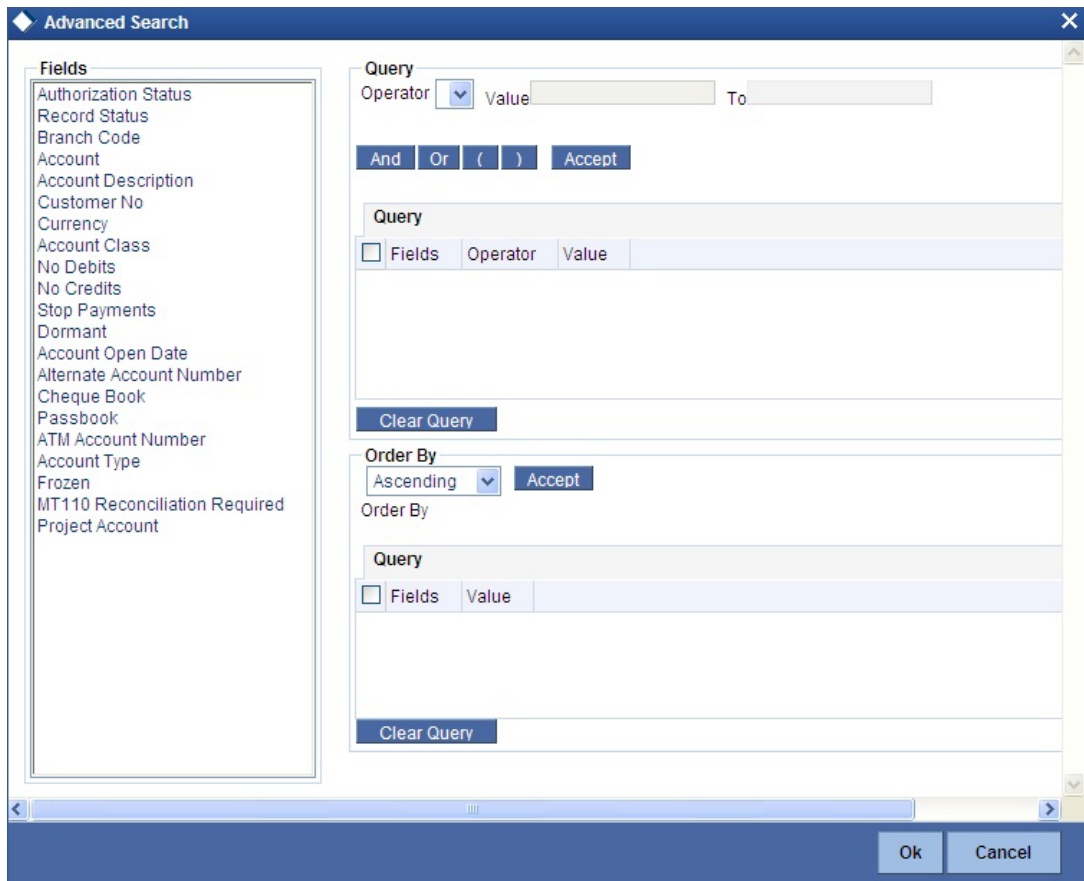

## 12.2 Procedure

The Query screen, will display all the fields that appear in the messaging module. These fields form the criteria based on which you can make a query.

If you do not wish to carry the query through, click 'Clear Query' button. The query screen is cleared and you can proceed to make a new query.



## 12.3 Making Query based on more than one criterion

Suppose you want to obtain information based on more than one criterion. For example, you may want to view the details of all the guarantees generated for the Letters of Credit module from your branch located at London.

### **Procedure**

The procedure to make such a query involves the following steps:

<b>Accept</b>	The Accept button
<b>And</b>	The And button

#### *Step 1*

Select 'Module' under 'Fields', and then from the Operator drop-down list choose Equal To and LC under Value. Then click the Accept button.

#### *Step 2*

Click the 'And' button. Repeat step one with the criteria value, as Message type, select Guarantee under value clicking accept and add buttons in the sequence described for the first criterion.

#### *Step 3*

Click the 'And' button. Repeat step one with the criteria value, as Branch select London under Value clicking accept and add buttons in the sequence described for the first criterion.

#### *Step 4*

The query that you have made will be displayed in the Query screen. Check it for correctness and click 'Ok' button.

The Outgoing Message Browser will display details of all the Guarantees generated for the LC module from your branch at London.

## 12.4 Selecting Same Criterion to Apply One or More Conditions

Now, you may want to make a query to see the debit advices (in the Letters of Credit module) that were generated from the London branch involving three different customers (Wendy Klien, Silas Reed and Keturah Smith).

This involves specifying a customer code one by one all of which come under the same criterion module -- LC (listed out under Fields) and indicating a message type for which you want details. This is where the 'Or' button on the query screen comes into play. You can choose to use the keyboard to key in the query or you can follow the following procedure to make a query.

### **Procedure**

#### *Step 1*

Select Module under Fields, and then from the Operator drop-down list choose Equal To and LC under Value. Then click the 'Accept' button.

### *Step 2*

Click the And button. Repeat step one with criteria Field as "Branch", Operator being "Equal To" and "London" under Value. Click the 'Accept' and 'Add' buttons in the sequence described in Step 1.

### *Step 3*

Click the And button. Repeat step one for Field with the criteria value, as Message Type. Then select Debit message under Value clicking the 'Accept' and 'Add' buttons in the sequence described for the first criterion.

### *Step 4*

To cull out details of the debit advices involving these three customers, click the And button. Repeat Step 1 with the 'Field' as 'Name'. Select say Ms. Keturah Smith under Value. Then click the accept button.

To select another customer, click the Or button and then click Name in the Fields list, specify the Operator as Equal To and pick out the customer name Mr. Silas Reed from the Value option list then click the Accept button.

Repeat the process for the third customer, Ms. Wendy Klien.

### *Step 5*

The query that you have made is displayed on the Query screen.

```
MODULE = LC AND BRANCH = LONDON AND MSG_TYPE = DR_ADV AND NAME =  
SILAS REED OR NAME = KETURAH SMITH OR NAME = WENDY KLIEN
```

Check it for correctness and click 'Ok' button to see the query through. The Outgoing Message Browser will display details of all the debit advices generated for the LC module from your branch at London to the three customers that you specified.

## 12.5 Ordering Details of Query

Oracle FLEXCUBE also provides you the option to order the information that you have made a query on. You can further specify that the ordered information should be arranged in ascending or descending order.

Suppose you have made a query to obtain details of the debit messages that were generated by the Data Entry module of Oracle FLEXCUBE, and you wish to order the information in the ascending order of the customer to whom the message was sent.

Make the query following the procedure detailed under the head making a Query after you have specified the entire criterion for the query, select the required ordering option from the Order By drop-down list. The list contains the following options:

- Ascending
- Descending

Click the option of your choice, say, Descending.

Click the 'Accept' button and click 'Ok'. The details of the query that you have made will be displayed on the Outgoing Browser ordered on the basis of the customer to whom the message was sent. The details will further be sorted in the alphabetic order.

If you decide to cancel the ordering you have specified, click 'Clear Query'. The screen clears and you can specify a new order.

## 12.6 Using Wildcards to make Query

You need not always specify the criteria for a query. You can use wild cards such as:

Wild Card	Description	Implication
_	Underscore	To match a single character
%	Percent	To match any string of multiple characters

**Using %**

For instance, if you have to check the messages relating to one particular Loans product LD01, you can query for records with Reference Number like '%LD01%' since all the contract reference numbers with that product will invariably contain that string.

Once you click the Accept button and make a query, the 'Outgoing Message Browser' screen displays all the Free Format Texts.

**Using And**

When you are searching for strings of specific length which vary in only one character – for instance, all branches like 001, 002, 003 – can be represented as 00\_. Searching for 00\_ will fetch all the messages for all these three branches.

---

# 13. Processing SWIFT Messages

## 13.1 Introduction

SWIFT is the 'Society for Worldwide Interbank Financial Telecommunication', a member-owned cooperative through which the financial world conducts its business operations with speed, certainty and confidence. SWIFT enables customers to automate and standardise financial transactions, thereby lowering costs, reducing operational risk and eliminating inefficiencies from their operations.

SWIFT is solely a carrier of messages. It does not hold funds nor does it manage accounts on behalf of customers, nor does it store financial information on an on-going basis. As a data carrier, SWIFT transports messages between two financial institutions. This activity involves the secure exchange of proprietary data while ensuring its confidentiality and integrity.

There are four key areas that SWIFT services fall under within the financial marketplace. They are Securities, Treasury and Derivatives, Trade Services, and Payments & Cash Management.

SWIFT messages consist of five blocks of data including three headers, message content, and a trailer. They are identified in a consistent manner. They all start with the literal 'MT' which denotes Message Type. This is followed by a 3-digit number that denotes the message type, category, and group. The following are the categories of a message:

Category	Description
Category 1	Customer Payments and Cheques
Category 2	Financial Institution Transfers
Category 3	Treasury Markets - Foreign Exchange, Money Markets and Derivatives
Category 4	Collections and Cash Letters
Category 5	Securities Markets
Category 6	Treasury Markets - Metals
Category 7	Documentary Credits and Guarantees
Category 8	Travellers Cheques
Category 9	Cash Management and Customer Status
Category n	Common Group Messages

The following SWIFT message types are generated for the various transfers that are initiated through Oracle FLEXCUBE.

## 13.2 Customer Payments and Cheques

Category 1 consists of the following types of customer related payment messages:

- customer credit transfers
- customer debit transfers

- cheque payments

The messages in this category deal with payments, or information about payments, in which the ordering party or the beneficiary, or both, are not financial institutions.

### 13.2.0.1 **MT 102 Multiple Customer Credit Transfer**

This message is sent by or on behalf of the financial institution of the ordering customer(s) to another financial institution for payment to the beneficiary customer.

It requests the Receiver to credit the beneficiary customer(s) directly or indirectly through a clearing mechanism or another financial institution, or to issue a cheque to the beneficiary.

This message is used to convey multiple payment instructions between financial institutions for clean payments. Its use is subject to bilateral/multilateral agreements between Sender and Receiver.

Amongst other things, these bilateral agreements cover the transaction amount limits, the currencies accepted and their settlement.

Maximum Length: 10000

### 13.2.0.2 **Format Specifications**

#### **Mandatory Sequence A General Information**

<b>Field Tag</b>	<b>Field Name</b>	<b>Format</b>	<b>Mandatory/ Optional</b>
20	File Reference	16x	M
23	Bank Operation Code	16x	M
51A	Sending Institution	[/1!a][/34x] 4!a2!a2!c[3!c]	O
50a	Ordering Customer	A, F, or K	O
52a	Ordering Institution	A, B, or C	O
26T	Transaction Type Code	3!c	O
77B	Regulatory Reporting	3*35x	O
71A	Details of Charges	3!a	O
36	Exchange Rate	12d	O

#### **Mandatory Repetitive Sequence B Transaction Details**

<b>Field Tag</b>	<b>Field Name</b>	<b>Format</b>	<b>Mandatory/ Optional</b>
21	Transaction Reference	16x	M
32B	Transaction Amount	3!a15d	M
50a	Ordering Customer	A, F, or K	O

52a	Ordering Institution	A, B, or C	O
57a	Account With Institution	A or C	O
59a	Beneficiary Customer	No letter option or A	M
70	Remittance Information	4*35x	O
26T	Transaction Type Code	3!c	O
77B	Regulatory Reporting	3*35x	O
33B	Currency/Instructed Amount	3!a15d	O
71A	Details of Charges	3!a	O
71F	Sender's Charges	3!a15d	O
71G	Receiver's Charges	3!a15d	O
36	Exchange Rate	12d	O

#### **Mandatory Sequence C Settlement Details**

<b>Field Tag</b>	<b>Field Name</b>	<b>Format</b>	<b>Mandatory/ Optional</b>
32A	Value Date, Currency Code, Amount	6!n3!a15d	M
19	Sum of Amounts	17d	O
71G	Sum of Receiver's Charges	3!a15d	O
13C	Time Indication	/8c/4!n1!x4!n	O
53a	Sender's Correspondent	A or C	O
54A	Receiver's Correspondent	[/1!a]/[34x] 4!a2!a2!c[3!c]	O
72	Sender to Receiver Information	6*35x	O

### **13.2.1 MT 103 Single Customer Credit Transfer**

This message type is sent by or on behalf of the financial institution of the ordering customer, directly or through (a) correspondent(s), to the financial institution of the beneficiary customer. It is used to convey a funds transfer instruction in which the ordering customer or the beneficiary customer, or both, are non-financial institutions from the perspective of the Sender.

This message may only be used for clean payment instructions. It must not be used to advise the remitting bank of a payment for a clean, e.g. cheque, collection, nor to provide the cover for a transaction whose completion was advised separately, e.g. via an MT 400.

Maximum Length: 10000  
Format Specifications

Field Tag	Field Name	Format	Mandatory/Optional
20	Sender's Reference	16x	M
13C	Time Indication	/8c/4!n1!x4!n	O
23B	Bank Operation Code	4!c	M
23E	Instruction Code	4!c[/30x]	O
26T	Transaction Type Code	3!c	O
32A	Value Date/Currency/Inter-bank Settled Amount	6!n3!a15d	M
33B	Currency/Instructed Amount	3!a15d	O
36	Exchange Rate	12d	O
50a	Ordering Customer	A, F, or K	M
51A	Sending Institution	[/1!a]/[34x] 4!a2!a2!c[3!c]	O
52a	Ordering Institution	A or D	O
53a	Sender's Correspondent	A, B, or D	O
54a	Receiver's Correspondent	A, B, or D	O
55a	Third Reimbursement Institution	A, B, or D	O
56a	Intermediary Institution	A, C, or D	O
57a	Account With Institution	A, B, C, or D	O
59a	Beneficiary Customer	No letter option or A	M
70	Remittance Information	4*35x	O
71A	Details of Charges	3!a	M
71F	Sender's Charges	3!a15d	O
71G	Receiver's Charges	3!a15d	O
72	Sender to Receiver Information	6*35x	O
77B	Regulatory Reporting	3*35x	O
77T	Envelope Contents	9000z	O



### **13.2.2 MT 103+ Single Customer Credit Transfer**

This message type is sent by or on behalf of the financial institution of the ordering customer, directly or through (a) correspondent(s), to the financial institution of the beneficiary customer. It is used to convey a funds transfer instruction in which the ordering customer or the beneficiary customer, or both, are non-financial institutions from the perspective of the Sender.

This message may only be used for clean payment instructions. It must not be used to advise the remitting bank of a payment for a clean, e.g. cheque, collection, nor to provide the cover for a transaction whose completion was advised separately, e.g. via an MT 400.

Maximum Length: 10000

### 13.2.2.1 Format Specifications

Field Tag	Field Name	Format	Mandatory/Optional
20	Sender's Reference	16x	M
13C	Time Indication	/8c/4!n1!x4!n	O
23B	Bank Operation Code	4!c	M
23E	Instruction Code	4!c[/30x]	O
26T	Transaction Type Code	3!c	O
32A	Value Date/Currency/Interbank Settled Amount	6!n3!a15d	M
33B	Currency/Instructed Amount	3!a15d	O
36	Exchange Rate	12d	O
50a	Ordering Customer	A, F, or K	M
52A	Ordering Institution	[/1!a]/[34x] 4!a2!a2!c[3!c]	O
53a	Sender's Correspondent	A or B	O
54A	Receiver's Correspondent	[/1!a]/[34x] 4!a2!a2!c[3!c]	O
55A	Third Reimbursement Institution	[/1!a]/[34x] 4!a2!a2!c[3!c]	O
56A	Intermediary Institution	[/1!a]/[34x] 4!a2!a2!c[3!c]	O
57A	Account With Institution	[/1!a]/[34x] 4!a2!a2!c[3!c]	O
59a	Beneficiary Customer	No letter option or A	M
70	Remittance Information	4*35x	O
71A	Details of Charges	3!a	M
71F	Sender's Charges	3!a15d	O
71G	Receiver's Charges	3!a15d	O
72	Sender to Receiver Information	6*35x	O
77B	Regulatory Reporting	3*35x	O

The differences between MT 103 and MT 103+ messages are as follows:

- Appropriate MT 103+ format validation is triggered by the code STP in the validation flag field 119 ({{3:{119: STP}}}) of the user header of the message (block 3)
- In MT 103+ message, fields 52, 54, 55, 56 and 57 may only be used with letter option A

- In MT 103+ message, field 53 may only be used with letter options A and B
- Field 51A is not used in MT 103+. This message may only be used on the FIN SWIFT network since it requires special validation.
- Field 23E may only contain codes CORT, INTC, SDVA and REPA in MT 103+
- If field 53a is used with option B in MT 103+ message, then the Party Identifier must be used
- For MT 103+ message, subfield 1 (Account) of either field 59 or 59A is always mandatory
- In MT 103+ message, code INS must be followed by a valid BIC for Field 72
- In MT 103+ message, codes REJT/RETN must not be used for Field 72
- Field 72 must not include ERI information in MT 103+

### 13.2.3 **MT 110 Advice of Cheque(s)**

This multiple message is sent by a drawer bank, or a bank acting on behalf of the drawer bank to the bank on which a/several cheque(s) has/have been drawn (the drawee bank).

It is used to advise the drawee bank, or confirm to an enquiring bank, the details concerning the cheque(s) referred to in the message.

Maximum Length: 2000

#### 13.2.3.1 **Format Specifications**

Field Tag	Field Name	Format	Mandatory/Optional
20	Sender's Reference	16x	M
53a	Sender's Correspondent	A, B, or D	O
54a	Receiver's Correspondent	A, B, or D	O
72	Sender to Receiver Information	6*35x	O
21	Cheque Number	16x	M
30	Date of Issue	6!n	M
32a	Amount	A or B	M
52a	Drawer Bank	A, B, or D	O
59	Payee	[/34x] 4*35x	M

### 13.2.4 **MT 111 Request for Stop Payment of a Cheque**

This single message type is sent by a drawer bank, or a bank acting on behalf of the drawer bank, to the bank on which a cheque has been drawn (the drawee bank).

It is used to request stop payment of the cheque referred to in the message.

Maximum Length: 2000

### 13.2.4.1 Format Specifications

Field Tag	Field Name	Format	Mandatory/ Optional
20	Sender's Reference	16x	M
21	Cheque Number	16x	M
30	Date of Issue	6!n	M
32a	Amount	A or B	M
52a	Drawer Bank	A, B, or D	O
59	Payee	[/34x] 4*35x	O
75	Queries	6*35x	O

### 13.2.5 MT 191 Request for Payment of Charges, Interest, and Other Expenses

This message type is sent by a financial institution to another financial institution.

It is used to request the payment of charges, interest and/or other expenses which are previously unknown to the Receiver.

Maximum Length: 2000

#### 13.2.5.1 Format Specifications

Field Tag	Field Name	Format	Mandatory/ Optional
20	Transaction Reference Number	16x	M
21	Related Reference	16x	M
32B	Currency Code, Amount	3!a15d	M
52a	Ordering Institution	A or D	O
57a	Account With Institution	A, B or D	O
71B	Details of Charges	6*35x	M
72	Sender to Receiver Information	6*35x	O

## 13.3 Financial Institution Transfers

### 13.3.1 MT 200 Financial Institution Transfer for its Own Account

This message type is sent by an account owner to one of its account servicing institutions. It is used for single funds transfer between two accounts of the beneficiary bank maintained with two different financial institutions.

It is used to request the movement of funds from an account that the Receiver services for the Sender to an account that the Sender has, in the same currency, with another financial institution.

Maximum Length: 2000

**13.3.1.1 Format Specifications**

<b>Field Tag</b>	<b>Field Name</b>	<b>Format</b>	<b>Mandatory/ Optional</b>
20	Transaction Reference Number	16x	M
32A	Value Date, Currency Code, Amount	6!n3!a15d	M
53B	Sender's Correspondent	[/1!a][/ 34x] [35x]	O
56a	Intermediary	A or D	O
57a	Account With Institution	A, B, or D	M
72	Sender to Receiver Information	6*35x	O

**13.3.2 MT 202 General Financial Institution Transfer**

Requests the movement of funds between financial institutions

Maximum Length: 2000

### 13.3.2.1 Format Specifications

Field Tag	Field Name	Format	Mandatory/Optional
20	Transaction Reference Number	16x	M
21	Related Reference	16x	M
13C	Time Indicator	/8c/ 4!n1!s4!n	O
32A	Value Date, Currency Code, Amount	6!n3!a15d	M
52a	Ordering Institution	A or D	O
53a	Sender's Correspondent	A, B or D	O
54a	Receiver's Correspondent	A, B or D	O
56a	Intermediary	A or D	O
57a	Account With Institution	A, B or D	O
58a	Beneficiary Institution	A or D	M
72	Sender to Receiver Information	6*35x	O

---

#### Note

'TSU - Trade Services Utility transaction' is supported for field 72 in this particular message.

---

### 13.3.3 MT 203 Multiple General Financial Institution Transfer

This multiple message is sent by or on behalf of the ordering institution directly, or through correspondent(s), to the financial institution(s) of several beneficiary institution(s). The message contains several transactions.

It is used to order the movement of funds to each beneficiary institution.

This message may also contain order(s) for the movement of the Sender's own funds in favour of itself. This is the case when the Receiver services multiple accounts for the Sender and the funds are to be transferred between these accounts. In addition, it can be sent to a financial institution to debit an account of the Sender serviced by the Receiver and to credit an account owned by the Sender at an institution specified in field 57a.

Maximum Length: 2000

### 13.3.3.1 Format Specifications

Field Tag	Field Name	Format	Mandatory/Optional
19	Sum of Amounts	17d	M
30	Value Date	6!n	M
52a	Ordering Institution	A or D	O
53a	Sender's Correspondent	A, B, or D	O
54a	Receiver's Correspondent	A, B, or D	O
72	Sender to Receiver Information	6*35x	O
20	Transaction Reference Number	16x	M
21	Related Reference	16x	M
32B	Currency Code, Amount	3!a15d	M
56a	Intermediary	A or D	O
57a	Account With Institution	A, B, or D	O
58a	Beneficiary Institution	A or D	M
72	Sender to Receiver Information	6*35x	O

### 13.3.4 MT 204 Financial Markets Direct Debit Message

Claims funds from SWIFT member banks

Maximum Length: 2000

#### 13.3.4.1 Format Specifications

##### Sequence A

Field Tag	Field Name	Format	Mandatory/Optional
20	Transaction Reference Number	16x	M
19	Sum of Amounts	17d	M
30	Value Date	6!n	M
57a	Account with Institution	A, B or D	O
58a	Beneficiary Institution	A or D	O
72	Sender to Receiver Information	6*35x	O

## Sequence B

Field Tag	Field Name	Format	Mandatory/Optional
20	Transaction Reference Number	16x	M
21	Related Reference	16x	O
32B	Transaction Amount	3!a15d	M
53a	Debit Institution	A, B or D	M
72	Sender to Receiver Information	6*35x	O

---

### Note

'TSU - Trade Services Utility transaction' is supported for field 72 in this particular message.

---

### 13.3.5 MT 205 Financial Institution Transfer Execution

This message is sent by the Receiver of a category 2 transfer message, ie, MT 200, 201, 202, 203 or 205, directly or through correspondent(s), to another financial institution located in the same country as the Sender.

It is used to further transmit a funds transfer instruction domestically.

Maximum Length: 2000



### 13.3.5.1 Format Specifications

Field Tag	Field Name	Format	Mandatory/Optional
20	Transaction Reference Number	16x	M
21	Related Reference	16x	M
13C	Time Indication	/8c/ 4!n1!x4!n	O
32A	Value Date, Currency Code, Amount	6!n3!a15d	M
52a	Ordering Institution	A or D	M
53a	Sender's Correspondent	A, B, or D	O
56a	Intermediary	A or D	O
57a	Account With Institution	A, B, or D	O
58a	Beneficiary Institution	A or D	M
72	Sender to Receiver Information	6*35x	O

### 13.3.6 MT 210 Notice to Receive

This message type is sent by an account owner to one of its account servicing institutions.

It is an advance notice to the account servicing institution that it will receive funds to be credited to the Sender's account.

Maximum Length: 2000

### 13.3.6.1 Format Specifications

Field Tag	Field Name	Format	Mandatory/Optional
20	Transaction Reference Number	16x	M
25	Account Identification	35x	O
30	Value Date	6!n	M
21	Related Reference	16x	M
32B	Currency Code, Amount	3!a15d	M
50a	Ordering Customer	No letter option, C, or F	O
52a	Ordering Institution	A or D	O
56a	Intermediary	A or D	O

## 13.4 Treasury Markets - Foreign Exchange, Money Markets and Derivatives

### 13.4.1 MT 300 Foreign Exchange Confirmation

This message is exchanged by or on behalf of the institutions or corporate, party A and party B, which have agreed to a foreign exchange contract.

This message may also be sent by a money broker to the two parties (party A and party B) for which the broker arranged the deal.

This message is also used when one of the trading parties is a fund manager as the fund manager has to specify the fund for which he is dealing.

The MT 300 is used to:

- confirm the details of a new contract between the parties
- confirm an exercised foreign currency option
- confirm the details of an amendment to a previously sent confirmation
- Cancel a previously sent confirmation.

Maximum Length: 10000

### 13.4.1.1 Format Specifications

#### Mandatory Sequence A General Information

Field Tag	Field Name	Format	Mandatory/Optional
15A	New Sequence	Empty field	M
20	Sender's Reference	16x	M
21	Related Reference	16x	O
22A	Type of Operation	4!c	M
94A	Scope of Operation	4!c	O
22C	Common Reference	4!a2!c4!n4!a2!c	M
17T	Block Trade Indicator	1!a	O
17U	Split Settlement Indicator	1!a	O
82a	Party A	A, D, or J	M
87a	Party B	A, D, or J	M
83a	Fund or Beneficiary Customer	A, D, or J	O
77D	Terms and Conditions	6*35x	O

#### Mandatory Sequence B Transaction Details

Field Tag	Field Name	Format	Mandatory/Optional
15B	New Sequence	Empty field	M
30T	Trade Date	8!n	M
30V	Value Date	8!n	M
36	Exchange Rate	12d	M

#### Mandatory Subsequence B1 Amount Bought

Field Tag	Field Name	Format	Mandatory/Optional
32B	Currency, Amount	3!a15d	M
53a	Delivery Agent	A, D, or J	O
56a	Intermediary	A, D, or J	O
57a	Receiving Agent	A, D, or J	M

**Mandatory Subsequence B2 Amount Sold**

<b>Field Tag</b>	<b>Field Name</b>	<b>Format</b>	<b>Mandatory/Optional</b>
33B	Currency, Amount	3!a15d	M
53a	Delivery Agent	A, D, or J	O
56a	Intermediary	A, D, or J	O
57a	Receiving Agent	A, D, or J	M
58a	Beneficiary Institution	A, D, or J	O

**Optional Sequence C Optional General Information**

<b>Field Tag</b>	<b>Field Name</b>	<b>Format</b>	<b>Mandatory/Optional</b>
15C	New Sequence	Empty field	M
29A	Contact Information	4*35x	O
24D	Dealing Method	4!c[/35x]	O
84a	Dealing Branch Party A	A, B, D, or J	O
85a	Dealing Branch Party B	A, B, D, or J	O
88a	Broker Identification	A, D, or J	O
71F	Broker's Commission	3!a15d	O
26H	Counterparty's Reference	16x	O
21G	Broker's Reference	16x	O
72	Sender to Receiver Information	6*35x	O

#### Optional Sequence D Split Settlement Details

Field Tag	Field Name	Format	Mandatory/Optional
15D	New Sequence	Empty field	M
17A	Buy (Sell) Indicator	1!a	M
32B	Currency, Amount	3!a15d	M
53a	Delivery Agent	A, D, or J	O
56a	Intermediary	A, D, or J	O
57a	Receiving Agent	A, D, or J	M
58a	Beneficiary Institution	A, D, or J	O
16A	Number of Settlements	5n	M

#### 13.4.2 MT 305 Foreign Currency Option Confirmations

This message type is exchanged between the financial institutions which have agreed to a foreign currency option contract.

It is used to confirm the details of:

- a new contract between the parties
- an amendment to a previously agreed contract
- the cancellation of a confirmation

the surrender of an option by the buyer (holder) to the seller (grantor) for compensation

Maximum Length: 2000

### 13.4.2.1 Format Specifications

Field Tag	Field Name	Format	Mandatory/Optional
15A	New Sequence		M
20	Transaction Reference Number	16x	M
21	Related Reference	16x	M
22	Code/Common Reference	8a/4!a2!c4!n4!a2!c	M
23	Further Identification	16x	M
94A	Scope of Operation	4!c	O
82a	Party A	A, D, or J	M
87a	Party B	A, D, or J	M
83a	Fund or Beneficiary Customer	A, D, or J	O
30	Date Contract Agreed/Amended	6!n	M
31C	Earliest Exercise Date	6!n	O
31G	Expiry Details	6!n/4!n/12a	M
31E	Final Settlement Date	6!n	M
26F	Settlement Type	9a	M
32B	Underlying Currency and Amount	3!a15d	M
36	Strike Price	12d	M
33B	Counter Currency and Amount	3!a15d	M
37K	Premium Price	3!a12d	M
34a	Premium Payment	P or R	M
53a	Sender's Correspondent	A, B, or D	O
56a	Intermediary	A or D	O
57a	Account With Institution	A or D	M
77D	Terms and Conditions	6*35x	O
72	Sender to Receiver Information	6*35x	O

### 13.4.3 MT 306 Foreign Currency Option Confirmation

This message is exchanged to confirm a foreign currency option contract, by or on behalf of

the institutions or corporate, party A and party B, which have agreed to it.

A money broker may also send this message to the two parties (party A and party B) for which he arranged the deal. If there are two money brokers involved in arranging a deal between party A and party B, this message can also be exchanged between these money brokers.

The message is used to confirm/notify the details of:

- a new contract between the parties
- an amendment to a previously agreed contract
- the cancellation of a confirmation
- a trigger event: knock-in/knock-out of an option, hitting of a trigger level
- the close out of an option

Maximum Length: 10000

### 13.4.3.1 Format Specifications

#### Mandatory Sequence A General Information

Field Tag	Field Name	Format	Mandatory/Optional
12G	Option Type	4!c	O
15A	New Sequence	Empty field	M
20	Sender's Reference	16x	M
21	Related Reference	16x	O
22A	Type of Operation	4!c	M
94A	Scope of Operation	4!c	O
22C	Common Reference	4!a2!c4!n4!a2!c	M
21N	Contract Number Party A	16x	M
21B	Contract Number Party B	16x	O
12F	Option Style	4!c	M
12E	Expiration Style	4!c	M
17A	Barrier Indicator	1!a	M
17F	Non-Deliverable Indicator	1!a	M
22K	Type of Event	4!c[/35x]	M
30U	Date of Trigger Hit	8!n	O
29H	Location of Trigger Hit	4!c	O
82a	Party A	A, D, or J	M
87a	Party B	A, D, or J	M
83a	Fund or Beneficiary Customer	A, D, or J	O
77H	Type, Date, Version of the Agreement	6a[/8!n][//4!n]	M
77D	Additional Conditions	6*35x	O
14C	Year of Definitions	4!n	O

#### Mandatory Sequence B Transaction Details

Field Tag	Field Name	Format	Mandatory /Optional
15B	New Sequence	Empty field	M



17V	Buy (Sell) Indicator	1!a	M
30T	Trade Date	8!n	M
30X	Expiration Date	8!n	M
29E	Expiration Location and Time	4!c/4!n	M
30a	Final Settlement Date	F or J	M

#### Optional Subsequence B1 Premium Details

Field Tag	Field Name	Format	Mandatory/Optional
37K	Premium Price	3!a12d	O
30V	Premium Payment Date	8!n	M
34B	Premium Currency and Amount	3!a15d	M

#### Optional Subsequence B2 Calculation Agent

Field Tag	Field Name	Format	Mandatory/Optional
84a	Calculation Agent	A, B, D, or J	O

#### Optional Sequence C Settlement Instructions for Payment of Premium

Field Tag	Field Name	Format	Mandatory/Optional
15C	New Sequence	Empty field	M
53a	Delivery Agent	A, D, or J	O
86a	Intermediary 2	A, D, or J	O
56a	Intermediary	A, D, or J	O
57a	Receiving Agent	A, D, or J	M
58a	Beneficiary Institution	A, D, or J	O

**Optional Sequence D Vanilla Block**

Field Tag	Field Name	Format	Mandatory/Optional
15D	New Sequence	Empty field	M
30P	Earliest Exercise Date	8!n	O
30Q	Intermediate Exercise Date	8!n	O
26F	Settlement Type	9a	M
32B	Put Currency and Amount	3!a15d	M
36	Strike Price	12d	M
33B	Call Currency and Amount	3!a15d	M

**Optional Sequence E Payout Amount**

Field Tag	Field Name	Format	Mandatory/Optional
15E	New Sequence	Empty field	M
33E	Currency, Amount	3!a15d	M
30H	Touch Payment Date	8!n	O
53a	Delivery Agent	A, D, or J	O
86a	Intermediary 2	A, D, or J	O
56a	Intermediary	A, D, or J	O
57a	Receiving Agent	A, D, or J	M
58a	Beneficiary Institution	A, D, or J	O

**Optional Sequence F Barrier Block**

Field Tag	Field Name	Format	Mandatory/Optional
15F	New Sequence	Empty field	M
22G	Type of Barrier	4!c	M
37J	Barrier Level	12d	M
37L	Lower Barrier Level	12d	O

**Optional Subsequence F1 Barrier Window Block**

Field Tag	Field Name	Format	Mandatory/Optional
-----------	------------	--------	--------------------

30G	Barrier Window Start Date and End Date	8!n/8!n	M
29J	Location and Time for Start Date	4!c/4!n]	M
29K	Location and Time for End Date	4!c/4!n	M

**Optional Sequence G Trigger Block**

Field Tag	Field Name	Format	Mandatory/Optional
15G	New Sequence	Empty field	M
22J	Type of Trigger	4!c	M
37U	Trigger Level	12d	M
37P	Lower Trigger Level	12d	O
32Q	Currency Pair	3!a/3!a	M

**Optional Sequence H Non Deliverable Option Block**

Field Tag	Field Name	Format	Mandatory/Optional
15H	New Sequence	Empty field	M
14S	Settlement Rate Source	3!a2!n	M
32E	Settlement Currency	3!a	M

**Optional Sequence I Additional Information**

Field Tag	Field Name	Format	Mandatory/Optional
15I	New Sequence	Empty field	M
29A	Contact Information	4*35x	O
24D	Dealing Method	4!c[/35x]	O
88a	Broker Identification	A or D	O
71F	Broker's Commission	3!a15d	O
21G	Broker's Reference	16x	O
72	Sender to Receiver Information	6*35x	O

**Optional Sequence J Additional Amounts**

Field Tag	Field Name	Format	Mandatory/Optional
15J	New Sequence	Empty field	M
18A	Number of Repetitions	5n	M
30F	Payment Date	8!n	M
32H	Currency, Payment Amount	[N]3!a15d	M
53a	Delivery Agent	A, D, or J	O

86a	Intermediary 2	A, D, or J	O
56a	Intermediary	A, D, or J	O
57a	Receiving Agent	A, D, or J	M

#### 13.4.4 **MT 320 Fixed Loan/Deposit Confirmation**

This message is exchanged to confirm a fixed term loan/deposit contract, in order to confirm/notify the details of:

- a new contract between the parties
- an amendment to a previously agreed contract
- the cancellation of a confirmation
- a rolled over/renewed contract between the parties
- the maturity of a contract

This message is exchanged by or on behalf of the institutions or corporate, party A and party B, who have agreed to a fixed term loan/deposit contract. A money broker may also send this message to the two parties (party A and party B) for which he arranged the deal.

Maximum Length: 10000

##### 13.4.4.1 **Format Specifications**

###### **Mandatory Sequence A General Information**

Field Tag	Field Name	Format	Mandatory/Optional
15A	New Sequence	Empty field	M
20	Sender's Reference	16x	M
21	Related Reference	16x	O
22A	Type of Operation	4!c	M
94A	Scope of Operation	4!c	O
22B	Type of Event	4!c	M
22C	Common Reference	4!a2!c4!n4!a2! c	M
21N	Contract Number Party A	16x	O
82a	Party A	A, D, or J	M
87a	Party B	A, D, or J	M
83a	Fund or Instructing Party	A, D, or J	O
77D	Terms and Conditions	6*35x	O

**Mandatory Sequence B Transaction Details**

<b>Field Tag</b>	<b>Field Name</b>	<b>Format</b>	<b>Mandatory/ Optional</b>
15B	New Sequence	Empty field	M
17R	Party A's Role	1!a	M
30T	Trade Date	8!n	M
30V	Value Date	8!n	M
30P	Maturity Date	8!n	M
32B	Currency and Principal Amount	3!a15d	M
32H	Amount to be Settled	[N]3!a15d	O
30X	Next Interest Due Date	8!n	O
34E	Currency and Interest Amount	[N]3!a15d	M
37G	Interest Rate	[N]12d	M
14D	Day Count Fraction	7x	M
30F	Last Day of the First Interest Period	8!n	O
38J	Number of Days	1!a3!n	O

**Mandatory Sequence C Settlement Instructions for Amounts Payable by Party A**

<b>Field Tag</b>	<b>Field Name</b>	<b>Format</b>	<b>Mandatory/ Optional</b>
15C	New Sequence	Empty field	M
53a	Delivery Agent	A, D, or J	O
86a	Intermediary 2	A, D, or J	O
56a	Intermediary	A, D, or J	O
57a	Receiving Agent	A, D, or J	M
58a	Beneficiary Institution	A, D, or J	O

**Mandatory Sequence D Settlement Instructions for Amounts Payable by Party B**

<b>Field Tag</b>	<b>Field Name</b>	<b>Format</b>	<b>Mandatory/ Optional</b>
15D	New Sequence	Empty field	M
53a	Delivery Agent	A, D, or J	O

86a	Intermediary 2	A, D, or J	O
56a	Intermediary	A, D, or J	O
57a	Receiving Agent	A, D, or J	M
58a	Beneficiary Institution	A, D, or J	O

**Optional Sequence E Settlement Instructions for Interests Payable by Party A**

<b>Field Tag</b>	<b>Field Name</b>	<b>Format</b>	<b>Mandatory/ Optional</b>
15E	New Sequence	Empty field	M
53a	Delivery Agent	A, D, or J	O
86a	Intermediary 2	A, D, or J	O
56a	Intermediary	A, D, or J	O
57a	Receiving Agent	A, D, or J	M
58a	Beneficiary Institution	A, D, or J	O

**Optional Sequence F Settlement Instructions for Interests Payable by Party B**

<b>Field Tag</b>	<b>Field Name</b>	<b>Format</b>	<b>Mandatory/ Optional</b>
15F	New Sequence	Empty field	M
53a	Delivery Agent	A, D, or J	O
86a	Intermediary 2	A, D, or J	O
56a	Intermediary	A, D, or J	O
57a	Receiving Agent	A, D, or J	M
58a	Beneficiary Institution	A, D, or J	O

### Optional Sequence G Tax Information

Field Tag	Field Name	Format	Mandatory/ Optional
15G	New Sequence	Empty field	M
37L	Tax Rate	12d	M
33B	Transaction Currency and Net Interest Amount	3!a15d	M
36	Exchange Rate	12d	O
33E	Reporting Currency and Tax Amount	3!a15d	O

### Optional Sequence H Additional Information

Field Tag	Field Name	Format	Mandatory/ Optional
15H	New Sequence	Empty field	M
29A	Contact Information	4*35x	O
24D	Dealing Method	4!c[/35x]	O
84a	Dealing Branch Party A	A, B, D, or J	O
85a	Dealing Branch Party B	A, B, D, or J	O
88a	Broker Identification	A, D, or J	O
71F	Broker's Commission	3!a15d	O
26H	Counterparty's Reference	16x	O
21G	Broker's Reference	16x	O
72	Sender to Receiver Information	6*35x	O

### Optional Sequence I Additional Amounts

Field Tag	Field Name	Format	Mandatory/ Optional
15I	New Sequence	Empty field	M
18A	Number of Repetitions	5n	M
30F	Payment Date	8!n	M
32H	Currency, Payment Amount	[N]3!a15d	M
53a	Delivery Agent	A, D, or J	O
86a	Intermediary 2	A, D, or J	O



56a	Intermediary	A, D, or J	O
57a	Receiving Agent	A, D, or J	M

### 13.4.5 **MT 330 Call/Notice Loan/Deposit Confirmation**

This message is exchanged to confirm a call/notice loan/deposit contract.

The message is used to confirm/notify the details of:

- a new contract between the parties
- an amendment to a previously agreed contract
- the cancellation of a confirmation
- an increase or decrease in the balance of the account, in an already agreed contract
- a change in the interest rate
- a change in the period of notice
- the closing of a contract, i.e. final redemption of the loan/deposit balance to zero and all interest paid

This message is sent by or on behalf of the institution or corporate, party A and party B, who have agreed to a call/notice loan/deposit contract.

Maximum Length: 10000

#### 13.4.5.1 **Format Specifications**

##### **Mandatory Sequence A General Information**

Field Tag	Field Name	Format	Mandatory/Optional
15A	New Sequence	Empty field	M
20	Sender's Reference	16x	M
21	Related Reference	16x	O
22A	Type of Operation	4!c	M
94A	Scope of Operation	4!c	O
22B	Type of Event	4!c	M
22C	Common Reference	4!a2!c4!n4!a2! c	M
21N	Contract Number Party A	16x	O
82a	Party A	A, D, or J	M
87a	Party B	A, D, or J	M
83a	Fund or Instructing Party	A, D, or J	O
77D	Terms and Conditions	6*35x	O

**Mandatory Sequence B Transaction Details**

Field Tag	Field Name	Format	Mandatory/ Optional
15B	New Sequence	Empty field	M
17R	Party A's Role	1!a	M
30T	Trade Date	8!n	M
30V	Value Date	8!n	M
38A	Period of Notice	3n	M
32B	Currency and Balance	3!a15d	O
32H	Principal Amount to be Settled	[N]3!a15d	O
30X	Interest Due Date	8!n	O
34E	Currency and Interest Amount	[N]3!a15d	O
37G	Interest Rate	[N]12d	M
14D	Day Count Fraction	7x	M
30F	Last Day of the Next Interest Period	8!n	O
38J	Number of Days	1!a3!n	O

**Mandatory Sequence C Settlement Instructions for Amounts Payable by Party A**

Field Tag	Field Name	Format	Mandatory/ Optional
15C	New Sequence	Empty field	M
53a	Delivery Agent	A, D, or J	O
86a	Intermediary 2	A, D, or J	O
56a	Intermediary	A, D, or J	O
57a	Receiving Agent	A, D, or J	M
58a	Beneficiary Institution	A, D, or J	O

**Mandatory Sequence D Settlement Instructions for Amounts Payable by Party B**

Field Tag	Field Name	Format	Mandatory/ Optional
15D	New Sequence	Empty field	M
53a	Delivery Agent	A, D, or J	O
86a	Intermediary 2	A, D, or J	O

56a	Intermediary	A, D, or J	O
57a	Receiving Agent	A, D, or J	M
58a	Beneficiary Institution	A, D, or J	O

**Optional Sequence E Settlement Instructions for Interests Payable by Party A**

<b>Field Tag</b>	<b>Field Name</b>	<b>Format</b>	<b>Mandatory/ Optional</b>
15E	New Sequence	Empty field	M
53a	Delivery Agent	A, D, or J	O
86a	Intermediary 2	A, D, or J	O
56a	Intermediary	A, D, or J	O
57a	Receiving Agent	A, D, or J	M
58a	Beneficiary Institution	A, D, or J	O

**Optional Sequence F Settlement Instructions for Interests Payable by Party B**

<b>Field Tag</b>	<b>Field Name</b>	<b>Format</b>	<b>Mandatory/ Optional</b>
15F	New Sequence	Empty field	M
53a	Delivery Agent	A, D, or J	O
86a	Intermediary 2	A, D, or J	O
56a	Intermediary	A, D, or J	O
57a	Receiving Agent	A, D, or J	M
58a	Beneficiary Institution	A, D, or J	O

### Optional Sequence G Tax Information

Field Tag	Field Name	Format	Mandatory/Optional
15G	New Sequence	Empty field	M
37L	Tax Rate	12d	M
33B	Transaction Currency and Net Interest Amount	3!a15d	M
36	Exchange Rate	12d	O
33E	Reporting Currency and Tax Amount	3!a15d	O

### Optional Sequence H Additional Information

Field Tag	Field Name	Format	Mandatory/Optional
15H	New Sequence	Empty field	M
29A	Contact Information	4*35x	O
24D	Dealing Method	4!c[/35x]	O
84a	Dealing Branch Party A	A, B, D, or J	O
85a	Dealing Branch Party B	A, B, D, or J	O
26H	Counterparty's Reference	16x	O
72	Sender to Receiver Information	6*35x	O

#### 13.4.6 **MT 340 Forward Rate Agreement Confirmation**

This message is exchanged by or on behalf of the institutions or corporates, party A and party B, who have agreed to a forward rate agreement (FRA).

The confirmed transaction is covered by an ISDA (International Swaps and Derivatives Association), Deutscher Rahmenvertrag für Finanztermingeschäfte, FRABBA (British Bankers' Association) or AFB (Association Française de Banques) Master Agreement. These agreements are either signed or under negotiation.

A money broker may also send this message to the two parties (party A and party B) for which he arranged the deal.

If there are two money brokers involved in arranging a deal between party A and party B, this message is also exchanged between these money brokers.

The message is used to confirm/notify the details of:

- a new contract between the parties
- an amendment to a previously agreed contract
- the cancellation of a confirmation

Maximum Length: 10000

### 13.4.6.1 Format Specifications

#### Mandatory Sequence A General Information

Field Tag	Field Name	Format	Mandatory/Optional
15A	New Sequence	Empty field	M
20	Sender's Reference	16x	M
21	Related Reference	16x	O
22A	Type of Operation	4!c	M
94A	Scope of Operation	4!c	O
22C	Common Reference	4!a2!c4!n4!a2! c	M
23D	Type of FRA	10a	M
21N	Contract Number Party A	16x	O
21B	Contract Number Party B	16x	O
82a	Party A	A or D	M
87a	Party B	A or D	M
77H	Type, Date, Version of the Agreement	6a[/8!n][//4!n]	M
14C	Year of Definitions	4!n	O

#### Mandatory Sequence B Transaction Details

Field Tag	Field Name	Format	Mandatory/Optional
15B	New Sequence	Empty field	M
30T	Trade Date	8!n	M
32B	Currency, Notional Amount	3!a15d	M
30F	Effective Date	8!n	M
30P	Termination Date	8!n	M
37M	Fixed Rate	[N]12d	M
14F	Floating Rate Option	24x	M

### Optional Subsequence B1 AFB and FRABBA Details

Field Tag	Field Name	Format	Mandatory/ Optional
30V	Fixing Date	8!n	M
38D	Contract Period	4n	M

### Mandatory Subsequence B2 Other Details

Field Tag	Field Name	Format	Mandatory/ Optional
38G	Designated Maturity	2n1!a/2n1!a	M
14D	Floating Rate Day Count Fraction	7x	M
17F	FRA Discounting	1!a	M
18A	Number of Repetitions	5n	M
22B	Financial Centre	4!c	M

### Mandatory Sequence C Settlement Instructions for Settlement Amount Payable by Party B

Field Tag	Field Name	Format	Mandatory/ Optional
15C	New Sequence	Empty field	M
53a	Delivery Agent	A, D, or J	O
86a	Intermediary 2	A, D, or J	O
56a	Intermediary	A, D, or J	O
57a	Receiving Agent	A, D, or J	M
58a	Beneficiary Institution	A, D, or J	O

### Mandatory Sequence D Settlement Instructions for Settlement Amount Payable by Party A

Field Tag	Field Name	Format	Mandatory/ Optional
15D	New Sequence	Empty field	M
53a	Delivery Agent	A, D, or J	O
86a	Intermediary 2	A, D, or J	O
56a	Intermediary	A, D, or J	O
57a	Receiving Agent	A, D, or J	M

58a	Beneficiary Institution	A, D, or J	O
-----	-------------------------	------------	---

#### Optional Sequence E Additional Information

Field Tag	Field Name	Format	Mandatory/Optional
15E	New Sequence	Empty field	M
29A	Contact Information	4*35x	O
24D	Dealing Method	4!c[/35x]	O
88a	Broker Identification	A or D	O
71F	Broker's Commission	3!a15d	O
21G	Broker's Reference	16x	O
72	Sender to Receiver Information	6*35x	O

#### c3Optional Sequence F Additional Amounts

Field Tag	Field Name	Format	Mandatory/Optional
15F	New Sequence	Empty field	M
18A	Number of Repetitions	5n	M
30F	Payment Date	8!n	M
32H	Currency, Payment Amount	[N]3!a15d	M
53a	Delivery Agent	A, D, or J	O
86a	Intermediary 2	A, D, or J	O
56a	Intermediary	A, D, or J	O
57a	Receiving Agent	A, D, or J	M

### 13.4.7 MT 341 Forward Rate Agreement Settlement Confirmation

This message is exchanged by or on behalf of the institutions or corporates, party A and party B, who have agreed to a forward rate agreement (FRA).

It is used to confirm the settlement details of the forward rate agreement when the settlement rate has been fixed on the fixing date.

The message is also used for:

- an amendment to a previously agreed settlement message
- the cancellation of a settlement message

Maximum Length: 10000

### 13.4.7.1 Format Specifications

#### Mandatory Sequence A General Information

Field Tag	Field Name	Format	Mandatory/Optional
15A	New Sequence	Empty field	M
20	Sender's Reference	16x	M
21	Related Reference	16x	O
22A	Type of Operation	4!c	M
94A	Scope of Operation	4!c	O
22C	Common Reference	4!a2!c4!n4!a2!c	M
23D	Type of FRA	10a	M
21N	Contract Number Party A	16x	O
21B	Contract Number Party B	16x	O
82a	Party A	A or D	M
87a	Party B	A or D	M
29A	Contact Information	4*35x	O
72	Sender to Receiver Information	6*35x	O

#### Mandatory Sequence B Transaction Details

Field Tag	Field Name	Format	Mandatory/Optional
15B	New Sequence	Empty field	M
30T	Trade Date	8!n	M
32B	Currency, Notional Amount	3!a15d	M
30F	Effective Date	8!n	M
30P	Termination Date	8!n	M
37M	Fixed Rate	[N]12d	M

#### Optional Subsequence B1 AFB and FRABBA Details

Field Tag	Field Name	Format	Mandatory/Optional
30V	Fixing Date	8!n	O



38D	Contract Period	4n	O
-----	-----------------	----	---

**Mandatory Sequence C Settlement Instructions for the Settlement Amount**

Field Tag	Field Name	Format	Mandatory/Optional
15C	New Sequence	Empty field	M
37R	Settlement Rate	[N]12d	M
34E	Settlement Currency and Amount	[N]3!a15d	M
53a	Delivery Agent	A, D, or J	O
86a	Intermediary 2	A, D, or J	O
56a	Intermediary	A, D, or J	O
57a	Receiving Agent	A, D, or J	M
58a	Beneficiary Institution	A, D, or J	O

**13.4.8 MT 350 Advice of Loan/Deposit Interest Payment**

It is used to inform that an interest amount has been paid to the account of the beneficiary with the receiving agent mentioned in the message.

The message may also be used to notify the details of:

- an amendment to a previously sent advice
- the cancellation of an advice

This message is sent by or on behalf of the institution or corporate, party A who has borrowed cash from the institution or corporate, party B.

Maximum Length: 10000

### 13.4.8.1 Format Specifications

#### Mandatory Sequence A General Information

Field Tag	Field Name	Format	Mandatory/Optional
15A	New Sequence	Empty field	M
20	Sender's Reference	16x	M
21	Related Reference	16x	O
22A	Type of Operation	4!c	M
94A	Scope of Operation	4!c	O
22C	Common Reference	4!a2!c4!n4!a2!c	M
21N	Contract Number Party A	16x	O
82a	Party A	A, D, or J	M
87a	Party B	A, D, or J	M
83a	Fund or Instructing Party	A, D, or J	O
72	Sender to Receiver Information	6*35x	O

#### Mandatory Sequence B Interest Information

Field Tag	Field Name	Format	Mandatory/Optional
15B	New Sequence	Empty field	M
30G	Interest Period	8!n/8!n	M
32B	Currency and Principal Amount	3!a15d	M
30V	Value Date of Interest Payment	8!n	M
34B	Currency and Interest Amount	3!a15d	M
37J	Interest Rate	12d	M
14D	Day Count Fraction	7x	M
30F	Next Interest Payment Date	8!n	O

**Mandatory Sequence C Settlement Instructions**

Field Tag	Field Name	Format	Mandatory/ Optional
15C	New Sequence	Empty field	M
53a	Delivery Agent	A, D, or J	O
86a	Intermediary 2	A, D, or J	O
56a	Intermediary	A, D, or J	O
57a	Receiving Agent	A, D, or J	M
58a	Beneficiary Institution	A, D, or J	O

**Optional Sequence D Tax Information and Broker's Commission**

Field Tag	Field Name	Format	Mandatory/ Optional
15D	New Sequence	Empty field	M
34B	Transaction Currency and Interest Amount	3!a15d	M
33B	Transaction Currency and Net Interest Amount	3!a15d	M
36	Exchange Rate	12d	O

**Optional Subsequence D1 Tax Details**

Field Tag	Field Name	Format	Mandatory/ Optional
37L	Tax Rate	12d	M
33E	Reporting Currency and Tax Amount	3!a15d	M

**Optional Subsequence D2 Broker's Commission Information**

Field Tag	Field Name	Format	Mandatory/ Optional
71F	Broker's Commission	3!a15d	M
37L	Tax Rate on Broker's Commission	12d	O
33E	Reporting Currency and Tax Amount on Broker's Commission	3!a15d	O

**13.4.9 MT 360 Single Currency Interest Rate Derivative Confirmation**

This message is exchanged by or on behalf of the institutions or corporates, party A and party B, which have agreed to a single currency interest rate swap, a cap, a collar or a floor. The

confirmed transaction is covered by a BBAIRS (British Bankers' Association Interest Rate Swap), ISDA (International Swaps and Derivatives Association), Deutscher Rahmenvertrag für Finanztermingeschäfte or AFB (Association Française de Banques) Master Agreement.

The message also covers deals which are not part of an ISDA, AFB, Deutscher Rahmenvertrag für Finanztermingeschäfte or BBAIRS Master. In this case, party A and party B must have another bilateral agreement in place.

This message may also be sent by a money broker to the two parties (party A and party B) for which the broker arranged the deal.

If there are two money brokers involved in arranging a deal between party A and party B, this message is also exchanged between these money brokers.

The MT 360 may be used to:

- confirm the details of a new transaction between the parties
- correct a previously sent confirmation
- cancel a previously sent confirmation

Maximum Length: 10000

### 13.4.9.1 Format Specifications

#### Mandatory Sequence A General Information

Field Tag	Field Name	Format	Mandatory/Optional
15A	New Sequence	Empty field	M
20	Sender's Reference	16x	M
21	Related Reference	16x	O
22A	Type of Operation	4!c	M
94A	Scope of Operation	4!c	O
22C	Common Reference	4!a2!c4!n4!a2! c	M
23A	Identification of the Swap	10a/5a	M
21N	Contract Number Party A	16x	M
21B	Contract Number Party B	16x	O
30T	Trade Date	8!n	M
30V	Effective Date	8!n	M
30P	Termination Date	8!n	M
14A	Business Day Convention	9a	O
32B	Currency, Notional Amount	3!a15d	M
82a	Party A	A or D	M
87a	Party B	A or D	M
83a	Fund or Beneficiary Customer	A, D, or J	O
17A	Collateral Agreement Indicator	1!a	O
77H	Type, Date, Version of the Agreement	6a[/8!n][//4!n]	M
77D	Additional Conditions	6*35x	O
14C	Year of Definitions	4!n	M
72	Sender to Receiver Information	6*35x	O

#### Optional Sequence B Fixed Interest Payable by Party B

Field Tag	Field Name	Format	Mandatory/Optional
-----------	------------	--------	--------------------

15B	New Sequence	Empty field	M
37U	Fixed Rate	12d	O
37N	Details of Interest Rate	6*35x	O

**Optional Subsequence B1 Interest Details**

Field Tag	Field Name	Format	Mandatory/Optional
18A	Number of Repetitions	5n	M
30F	Payment Date	8!n	M
32M	Currency, Payment Amount	3!a15d	O
17F	Period End Date Adjustment Indicator	1!a	O
14D	Day Count Fraction	7x	O
14A	Business Day Convention	9a	M
18A	Number of Repetitions	5n	M
22B	Financial Centre	4!c	M

**Optional Sequence C Floating Interest Payable by Party B**

Field Tag	Field Name	Format	Mandatory/Optional
15C	New Sequence	Empty field	M
14F	Floating Rate Option	24x	M
37J	Cap Rate	12d	O
37L	Floor Rate	12d	O
37N	Details of Interest Rate	6*35x	O

**Optional Subsequence C1 Interest Details**

Field Tag	Field Name	Format	Mandatory/Optional
14J	Reset Date Specification	5a	M
14G	Averaging Frequency and Method	1!a/8!a	O
38E	Designated Maturity	2n1!a	M
18A	Number of Repetitions	5n	M
30F	Payment Date	8!n	M
17F	Period End Date Adjustment Indicator	1!a	M
14D	Day Count Fraction	7x	M

14A	Business Day Convention	9a	M
18A	Number of Repetitions	5n	M
22B	Financial Centre	4!c	M
37R	Spread	[N]12d	O



**Optional Subsequence C2 Compounding Details**

Field Tag	Field Name	Format	Mandatory/ Optional
22D	Compounding Type	4!c	M
18A	Number of Repetitions	5n	M
30X	Compounding Date	8!n	M

**Optional Subsequence C3 Interpolation for Stub Periods**

Field Tag	Field Name	Format	Mandatory/ Optional
38G	First Stub Period, Interpolation Period	2n1!a/2n1!a	O
38H	Last Stub Period, Interpolation Period	2n1!a/2n1!a	O

**Mandatory Sequence D Payment Instructions for Interest Payable by Party B**

Field Tag	Field Name	Format	Mandatory/ Optional
15D	New Sequence	Empty field	M
53a	Delivery Agent	A or D	O
56a	Intermediary	A or D	O
86a	Second Intermediary	A or D	O
57a	Receiving Agent	A or D	M

**Optional Sequence E Fixed Interest Payable by Party A**

Field Tag	Field Name	Format	Mandatory/ Optional
15E	New Sequence	Empty field	M
37U	Fixed Rate	12d	O
37N	Details of Interest Rate	6*35x	O

**Optional Subsequence E1 Interest Details**

Field Tag	Field Name	Format	Mandatory/ Optional
18A	Number of Repetitions	5n	M
30F	Payment Date	8!n	M

32M	Currency, Payment Amount	3!a15d	O
17F	Period End Date Adjustment Indicator	1!a	O
14D	Day Count Fraction	7x	O
14A	Business Day Convention	9a	M
18A	Number of Repetitions	5n	M
22B	Financial Centre	4!c	M

#### Optional Sequence F Floating Interest Payable by Party A

Field Tag	Field Name	Format	Mandatory/Optional
15F	New Sequence	Empty field	M
14F	Floating Rate Option	24x	M
37J	Cap Rate	12d	O
37L	Floor Rate	12d	O
37N	Details of Interest Rate	6*35x	O

#### Optional Subsequence F1 Interest Details

Field Tag	Field Name	Format	Mandatory/Optional
14J	Reset Date Specification	5a	M
14G	Averaging Frequency and Method	1!a/8!a	O
38E	Designated Maturity	2n1!a	M
18A	Number of Repetitions	5n	M
30F	Payment Date	8!n	M
17F	Period End Date Adjustment Indicator	1!a	M
14D	Day Count Fraction	7x	M
14A	Business Day Convention	9a	M
18A	Number of Repetitions	5n	M
22B	Financial Centre	4!c	M
37R	Spread	[N]12d	O

### Optional Subsequence F2 Compounding Details

Field Tag	Field Name	Format	Mandatory/Optional
22D	Compounding Type	4!c	M
18A	Number of Repetitions	5n	M
30X	Compounding Date	8!n	M

### Optional Subsequence F3 Interpolation for Stub Periods

Field Tag	Field Name	Format	Mandatory/Optional
38G	First Stub Period, Interpolation Period	2n1!a/ 2n1!a	O
38H	Last Stub Period, Interpolation Period	2n1!a/ 2n1!a	O

### Mandatory Sequence G Payment Instructions for Interest Payable by Party A

Field Tag	Field Name	Format	Mandatory/Optional
15G	New Sequence	Empty field	M
53a	Delivery Agent	A or D	O
56a	Intermediary	A or D	O
86a	Second Intermediary	A or D	O
57a	Receiving Agent	A or D	M

### Optional Sequence H Amortising Schedule

Field Tag	Field Name	Format	Mandatory/Optional
15H	New Sequence	Empty field	M
18A	Number of Repetitions	5n	M
30G	Variable Notional Start and End Date	8!n/8!n	M
32U	Outstanding Notional Currency and Amount	3!a15d	M
14A	Business Day Convention	9a	M
18A	Number of Repetitions	5n	M

22B	Financial Centre	4!c	M
-----	------------------	-----	---

**Optional Sequence L Additional Amounts Payable by Party B**

<b>Field Tag</b>	<b>Field Name</b>	<b>Format</b>	<b>Mandatory/ Optional</b>
15L	New Sequence	Empty field	M
18A	Number of Repetitions	5n	M
22E	Type of Payment	4!c	M
30F	Payment Date	8!n	M
32M	Currency, Payment Amount	3!a15d	M
14A	Business Day Convention	9a	M
18A	Number of Repetitions	5n	M
22B	Financial Centre	4!c	M
53a	Delivery Agent	A or D	O
56a	Intermediary	A or D	O
86a	Second Intermediary	A or D	O
57a	Receiving Agent	A or D	O

### Optional Sequence M Additional Amounts Payable by Party A

Field Tag	Field Name	Format	Mandatory/Optional
15M	New Sequence	Empty field	M
18A	Number of Repetitions	5n	M
22E	Type of Payment	4!c	M
30F	Payment Date	8!n	M
32M	Currency, Payment Amount	3!a15d	M
14A	Business Day Convention	9a	M
18A	Number of Repetitions	5n	M
22B	Financial Centre	4!c	M
53a	Delivery Agent	A or D	O
56a	Intermediary	A or D	O
86a	Second Intermediary	A or D	O
57a	Receiving Agent	A or D	O

### Optional Sequence N Optional General Information

Field Tag	Field Name	Format	Mandatory/Optional
15N	New Sequence	Empty field	M
29A	Contact Information	4*35x	O
24D	Dealing Method	4!c[/35x]	O
88a	Broker Identification	A or D	O
71F	Broker's Commission	3!a15d	O
21G	Broker's Reference	16x	O

#### 13.4.10 MT 361 Cross Currency Interest Rate Swap Confirmation

This message is exchanged by or on behalf of the institutions or corporates, party A and party B, which have agreed to a cross currency interest rate swap covered by a BBAIRS (British Bankers' Association Interest Rate Swap), Deutscher Rahmenvertrag für Finanztermingeschäfte or an ISDA (International Swaps and Derivatives Association) Master Agreement.

The message also covers deals which are not part of an ISDA, Deutscher Rahmenvertrag für Finanztermingeschäfte or BBAIRS Master. In this case, party A and party B must have another bilateral agreement in place, except under AFB (Association Française de Banques)

Master (until the AFB does define the interbank confirmation for cross currency swaps, the MT 361 cannot be used to confirm such transactions).

This message may also be sent by a money broker to the two parties (party A and party B) for which the broker arranged the deal.

If there are two money brokers involved in arranging a deal between party A and party B, this message is also exchanged between these money brokers.

The message may be used to:

- confirm the details of a new transaction between the parties
- correct a previously sent confirmation
- cancel a previously sent confirmation

Maximum Length: 10000

### 13.4.10.1 Format Specifications

#### Mandatory Sequence A General Information

Field Tag	Field Name	Format	Mandatory/Optional
15A	New Sequence	Empty field	M
20	Sender's Reference	16x	M
21	Related Reference	16x	O
22A	Type of Operation	4!c	M
94A	Scope of Operation	4!c	O
22C	Common Reference	4!a2!c4!n4!a2! c	M
23A	Identification of the Swap	10a/5a	M
21N	Contract Number Party A	16x	M
21B	Contract Number Party B	16x	O
30T	Trade Date	8!n	M
30V	Effective Date	8!n	M
30P	Termination Date	8!n	M
14A	Business Day Convention	9a	O
32B	Party B Currency and Notional Amount	3!a15d	M
33B	Party A Currency and Notional Amount	3!a15d	M
82a	Party A	A or D	M
87a	Party B	A or D	M
83a	Fund or Beneficiary Customer	A, D, or J	O
17A	Collateral Agreement Indicator	1!a	O
77H	Type, Date, Version of the Agreement	6a[/8!n][[/4!n]	M
77D	Additional Conditions	6*35x	O
14C	Year of Definitions	4!n	M
72	Sender to Receiver Information	6*35x	O

#### Optional Sequence B Fixed Interest Payable by Party B

Field Tag	Field Name	Format	Mandatory/ Optional
15B	New Sequence	Empty field	M
37U	Fixed Rate	12d	O
37N	Details of Interest Rate	6*35x	O

**Optional Subsequence B1 Interest Details**

Field Tag	Field Name	Format	Mandatory/ Optional
18A	Number of Repetitions	5n	M
30F	Payment Date	8!n	M
32M	Currency, Payment Amount	3!a15d	O
17F	Period End Date Adjustment Indicator	1!a	O
14D	Day Count Fraction	7x	O
14A	Business Day Convention	9a	M
18A	Number of Repetitions	5n	M
22B	Financial Centre	4!c	M

**Optional Sequence C Floating Interest Payable by Party B**

Field Tag	Field Name	Format	Mandatory/ Optional
15C	New Sequence	Empty field	M
14F	Floating Rate Option	24x	M
37J	Cap Rate	12d	O
37L	Floor Rate	12d	O
37N	Details of Interest Rate	6*35x	O

**Optional Subsequence C1 Interest Details**

Field Tag	Field Name	Format	Mandatory/ Optional
14J	Reset Date Specification	5a	M



14G	Averaging Frequency and Method	1!a/8!a	O
38E	Designated Maturity	2n1!a	M
18A	Number of Repetitions	5n	M
30F	Payment Date	8!n	M
17F	Period End Date Adjustment Indicator	1!a	M
14D	Day Count Fraction	7x	M
14A	Business Day Convention	9a	M
18A	Number of Repetitions	5n	M
22B	Financial Centre	4!c	M
37R	Spread	[N]12d	O

### Optional Subsequence C2 Compounding Details

Field Tag	Field Name	Format	Mandatory/Optional
22D	Compounding Type	4!c	M
18A	Number of Repetitions	5n	M
30X	Compounding Date	8!n	M

### Optional Subsequence C3 Interpolation for Stub Periods

Field Tag	Field Name	Format	Mandatory/Optional
38G	First Stub Period, Interpolation Period	2n1!a/ 2n1!a	O
38H	Last Stub Period, Interpolation Period	2n1!a/ 2n1!a	O

### Mandatory Sequence D Payment Instructions for Interest Payable by Party B

Field Tag	Field Name	Format	Mandatory/Optional
15D	New Sequence	Empty field	M
53a	Delivery Agent	A or D	O
56a	Intermediary	A or D	O
86a	Second Intermediary	A or D	O
57a	Receiving Agent	A or D	M

### Optional Sequence E Fixed Interest Payable by Party A

Field Tag	Field Name	Format	Mandatory/Optional
15E	New Sequence	Empty field	M
37U	Fixed Rate	12d	O
37N	Details of Interest Rate	6*35x	O

### Optional Subsequence E1 Interest Details

<b>Field Tag</b>	<b>Field Name</b>	<b>Format</b>	<b>Mandatory/Optional</b>
18A	Number of Repetitions	5n	M
30F	Payment Date	8ln	M
32M	Currency, Payment Amount	3!a15d	O
17F	Period End Date Adjustment Indicator	1!a	O
14D	Day Count Fraction	7x	O
14A	Business Day Convention	9a	M
18A	Number of Repetitions	5n	M
22B	Financial Centre	4!c	M

**Optional Sequence F Floating Interest Payable by Party A**

<b>Field Tag</b>	<b>Field Name</b>	<b>Format</b>	<b>Mandatory/Optional</b>
15F	New Sequence	Empty field	M
14F	Floating Rate Option	24x	M
37J	Cap Rate	12d	O
37L	Floor Rate	12d	O
37N	Details of Interest Rate	6*35x	O

**Optional Subsequence F1 Interest Details**

Field Tag	Field Name	Format	Mandatory /Optional
14J	Reset Date Specification	5a	M
14G	Averaging Frequency and Method	1!a/8!a	O
38E	Designated Maturity	2n1!a	M
18A	Number of Repetitions	5n	M
30F	Payment Date	8!n	M
17F	Period End Date Adjustment Indicator	1!a	M
14D	Day Count Fraction	7x	M
14A	Business Day Convention	9a	M
18A	Number of Repetitions	5n	M
22B	Financial Centre	4!c	M
37R	Spread	[N]12d	O

#### Optional Subsequence F2 Compounding Details

Field Tag	Field Name	Format	Mandatory/Optional
22D	Compounding Type	4!c	M
18A	Number of Repetitions	5n	M
30X	Compounding Date	8!n	M

#### Optional Subsequence F3 Interpolation for Stub Periods

Field Tag	Field Name	Format	Mandatory/Optional
38G	First Stub Period, Interpolation Period	2n1!a/ 2n1!a	O
38H	Last Stub Period, Interpolation Period	2n1!a/ 2n1!a	O

### Mandatory Sequence G Payment Instructions for Interest Payable by Party A

Field Tag	Field Name	Format	Mandatory/Optional
15G	New Sequence	Empty field	M
53a	Delivery Agent	A or D	O
56a	Intermediary	A or D	O
86a	Second Intermediary	A or D	O
57a	Receiving Agent	A or D	M

### Optional Sequence H Amortizing Schedule for Party B

Field Tag	Field Name	Format	Mandatory/Optional
15H	New Sequence	Empty field	M
18A	Number of Repetitions	5n	M
30G	Variable Notional Start and End Date	8!n/8!n	M
32U	Outstanding Notional Currency and Amount	3!a15d	M
14A	Business Day Convention	9a	M
18A	Number of Repetitions	5n	M
22B	Financial Centre	4!c	M

### Optional Sequence I Amortizing Schedule for Party A

Field Tag	Field Name	Format	Mandatory/Optional
15I	New Sequence	Empty field	M
18A	Number of Repetitions	5n	M
30G	Variable Notional Start and End Date	8!n/8!n	M
32U	Outstanding Notional Currency and Amount	3!a15d	M
14A	Business Day Convention	9a	M
18A	Number of Repetitions	5n	M
22B	Financial Centre	4!c	M

**Optional Sequence J Exchanges of Principal Payable by Party B**

<b>Field Tag</b>	<b>Field Name</b>	<b>Format</b>	<b>Mandatory/ Optional</b>
15J	New Sequence	Empty field	M
18A	Number of Repetitions	5n	M
22X	Type of Exchange	4!c	M
30F	Payment Date	8!n	M
32M	Currency, Payment Amount	3!a15d	M
53a	Delivery Agent	A or D	O
56a	Intermediary	A or D	O
86a	Second Intermediary	A or D	O
57a	Receiving Agent	A or D	M
14A	Business Day Convention	9a	M
18A	Number of Repetitions	5n	M
22B	Financial Centre	4!c	M

**Optional Sequence K Exchanges of Principal Payable by Party A**

<b>Field Tag</b>	<b>Field Name</b>	<b>Format</b>	<b>Mandatory/ Optional</b>
15K	New Sequence	Empty field	M
18A	Number of Repetitions	5n	M
22X	Type of Exchange	4!c	M
30F	Payment Date	8!n	M
32M	Currency, Payment Amount	3!a15d	M
53a	Delivery Agent	A or D	O
56a	Intermediary	A or D	O
86a	Second Intermediary	A or D	O
57a	Receiving Agent	A or D	M
14A	Business Day Convention	9a	M
18A	Number of Repetitions	5n	M
22B	Financial Centre	4!c	M

**Optional Sequence L Additional Amounts Payable by Party B**

<b>Field Tag</b>	<b>Field Name</b>	<b>Format</b>	<b>Mandatory/ Optional</b>
15L	New Sequence	Empty field	M
18A	Number of Repetitions	5n	M
22E	Type of Payment	4!c	M
30F	Payment Date	8!n	M
32M	Currency, Payment Amount	3!a15d	M
14A	Business Day Convention	9a	M
18A	Number of Repetitions	5n	M
22B	Financial Centre	4!c	M
53a	Delivery Agent	A or D	O
56a	Intermediary	A or D	O
86a	Second Intermediary	A or D	O
57a	Receiving Agent	A or D	O

**Optional Sequence M Additional Amounts Payable by Party A**

<b>Field Tag</b>	<b>Field Name</b>	<b>Format</b>	<b>Mandatory/ Optional</b>
15M	New Sequence	Empty field	M
18A	Number of Repetitions	5n	M
22E	Type of Payment	4!c	M
30F	Payment Date	8!n	M
32M	Currency, Payment Amount	3!a15d	M
14A	Business Day Convention	9a	M
18A	Number of Repetitions	5n	M
22B	Financial Centre	4!c	M
53a	Delivery Agent	A or D	O
56a	Intermediary	A or D	O
86a	Second Intermediary	A or D	O
57a	Receiving Agent	A or D	O

### Optional Sequence N Optional General Information

Field Tag	Field Name	Format	Mandatory/Optional
15N	New Sequence	Empty field	M
29A	Contact Information	4*35x	O
24D	Dealing Method	4!c[/35x]	O
88a	Broker Identification	A or D	O
71F	Broker's Commission	3!a15d	O
21G	Broker's Reference	16x	O

#### 13.4.11 MT 362 Interest Rate Reset/Advice of Payment

This message is exchanged by or on behalf of the financial institutions, Party A and Party B, who have agreed to a single or cross currency interest rate derivative transaction, including caps, collars and floors.

This message may be used to:

- advise the details of the determination of the floating interest rate(s)
- advise the details of the payment of interest at the end of an interest period
- cancel a previously sent reset/advice
- correct errors in a previously sent reset/advice

Maximum Length: 2000



### 13.4.11.1 Format Specifications

#### Mandatory Sequence A General Information

Field Tag	Field Name	Format	Mandatory/Optional
15A	New Sequence	Empty field	M
20	Sender's Reference	16x	M
21	Related Reference	16x	O
22A	Type of Operation	4!c	M
94A	Scope of Operation	4!c	O
22C	Common Reference	4!a2!c4!n4!a2! c	M
23A	Identification of the Swap	10a/5a	M
21N	Contract Number Party A	16x	M
21B	Contract Number Party B	16x	O
30V	Effective Date	8!n	M
30P	Termination Date	8!n	M
82a	Party A	A or D	M
87a	Party B	A or D	M
83a	Fund or Beneficiary Customer	A, D, or J	O
29A	Contact Information	4*35x	O
72	Sender to Receiver Information	6*35x	O

#### Optional Sequence B Interest Rate/Principal Payable by Party B

Field Tag	Field Name	Format	Mandatory/Optional
15B	New Sequence	Empty field	M
33F	Calculation Notional Currency and Amount	3!a15d	M
30X	Period Start Date	8!n	M
30Q	Period End Date	8!n	O
37G	Reset Rate	[N]12d	M
37J	Cap Rate	12d	O

37L	Floor Rate	12d	O
37R	Spread	[N]12d	M
37M	Total Rate	[N]12d	M
30F	Payment Date	8!n	M
32H	Currency, Interest Amount	[N]3!a15d	O
33E	Currency, Principal Exchange Amount	3!a15d	O
37N	Details of Interest Rate	6*35x	O

**Optional Sequence C (Net) Amount(s) Payable by Party B**

<b>Field Tag</b>	<b>Field Name</b>	<b>Format</b>	<b>Mandatory/ Optional</b>
15C	New Sequence	Empty field	M
18A	Number of Repetitions	5n	M
30F	Payment Date	8!n	M
32M	Currency, Payment Amount	3!a15d	M
53a	Delivery Agent	A or D	O
56a	Intermediary	A or D	O
86a	Second Intermediary	A or D	O
57a	Receiving Agent	A or D	M

**Optional Sequence D Interest Rate/Principal Payable by Party A**

<b>Field Tag</b>	<b>Field Name</b>	<b>Format</b>	<b>Mandatory/ Optional</b>
15D	New Sequence	Empty field	M
33F	Calculation Notional Currency and Amount	3!a15d	M
30X	Period Start Date	8!n	M
30Q	Period End Date	8!n	O
37G	Reset Rate	[N]12d	M
37J	Cap Rate	12d	O
37L	Floor Rate	12d	O
37R	Spread	[N]12d	M
37M	Total Rate	[N]12d	M
30F	Payment Date	8!n	M
32H	Currency, Interest Amount	[N]3!a15d	O
33E	Currency, Principal Exchange Amount	3!a15d	O
37N	Details of Interest Rate	6*35x	O

**Optional Sequence E (Net) Amount(s) Payable by Party A**

<b>Field Tag</b>	<b>Field Name</b>	<b>Format</b>	<b>Mandatory/ Optional</b>
15E	New Sequence	Empty field	M
18A	Number of Repetitions	5n	M
30F	Payment Date	8!n	M
32M	Currency, Payment Amount	3!a15d	M
53a	Delivery Agent	A or D	O
56a	Intermediary	A or D	O
86a	Second Intermediary	A or D	O
57a	Receiving Agent	A or D	M

**13.4.12 MT 364 Single Currency Interest Rate Derivative Termination/Recouping Confirmation**

This message is exchanged by or on behalf of the institutions or corporates, party A and party

B, which have agreed to the termination, partial termination or recouping of a single currency interest rate swap, a cap, a collar or a floor. The terminated/recouped transaction is covered by a BBAIRS, ISDA or AFB or another bilateral agreement.

This message may be used to:

- confirm the details of the partial or full termination of an existing transaction between the parties
- confirm the details of the recouping of an existing transaction
- correct a previously sent termination/recouping
- cancel a previously sent termination/recouping

Maximum Length: 10000

### 13.4.12.1 Format Specifications

#### Mandatory Sequence A General Information

Field Tag	Field Name	Format	Mandatory/Optional
15A	New Sequence	Empty field	M
20	Sender's Reference	16x	M
21	Related Reference	16x	O
22A	Type of Operation	4!c	M
94A	Scope of Operation	4!c	O
22B	Type of Event	4!c	M
22C	Common Reference	4!a2!c4!n4!a2! c	M
23A	Identification of the Swap	10a/5a	M
21N	Contract Number Party A	16x	M
21B	Contract Number Party B	16x	O
30T	Termination/Recouping Trade Date	8!n	M
30Q	Termination/Recouping Effective Date	8!n	M
30P	Original Termination Date	8!n	M
30V	Original Effective Date	8!n	M
32B	Current Currency, Notional Amount	3!a15d	M
82a	Party A	A or D	M
87a	Party B	A or D	M
83a	Fund or Beneficiary Customer	A, D, or J	O
22D	Accrual of Interest Specification	4!c	O
32G	New Currency, Notional Amount	3!a15d	O
37N	Details of Interest Rate	6*35x	O
29A	Contact Information	4*35x	O
72	Sender to Receiver Information	6*35x	O

**Optional Sequence B Fixed Interest Payable by Party B**

Field Tag	Field Name	Format	Mandatory/Optional
15B	New Sequence	Empty field	M
37U	Current Fixed Rate	12d	M
37P	New Fixed Rate	12d	O

**Optional Sequence E Fixed Interest Payable by Party A**

Field Tag	Field Name	Format	Mandatory/Optional
15E	New Sequence	Empty field	M
37U	Current Fixed Rate	12d	M
37P	New Fixed Rate	12d	O

**Optional Sequence L Fee Payable by Party B**

Field Tag	Field Name	Format	Mandatory/Optional
15L	New Sequence	Empty field	M
30F	Payment Date	8!n	M
32M	Currency, Payment Amount	3!a15d	M
53a	Delivery Agent	A or D	O
56a	Intermediary	A or D	O
86a	Second Intermediary	A or D	O
57a	Receiving Agent	A or D	M

**Optional Sequence M Fee Payable by Party A**

Field Tag	Field Name	Format	Mandatory/Optional
15M	New Sequence	Empty field	M
30F	Payment Date	8!n	M
32M	Currency, Payment Amount	3!a15d	M

53a	Delivery Agent	A or D	O
56a	Intermediary	A or D	O
86a	Second Intermediary	A or D	O
57a	Receiving Agent	A or D	M

### **13.4.13 MT 365 Cross Currency Interest Rate Swap Termination/Recouping Confirmation**

This message is exchanged by or on behalf of the institutions or corporates, party A and party B, which have agreed to the termination, partial termination or recouping of a cross currency interest rate swap. The terminated/recouped transaction is covered by a BBAIRS, ISDA or another bilateral agreement.

The message may be used to:

- confirm the details of the partial or full termination of an existing transaction between the parties
- confirm the details of the recouping of an existing transaction
- correct a previously sent termination/recouping
- Cancel a previously sent termination/recouping

Maximum Length: 10000

### 13.4.13.1 Format Specifications

#### Mandatory Sequence A General Information

Field Tag	Field Name	Format	Mandatory/Optional
15A	New Sequence	Empty field	M
20	Sender's Reference	16x	M
21	Related Reference	16x	O
22A	Type of Operation	4!c	M
94A	Scope of Operation	4!c	O
22B	Type of Event	4!c	M
22C	Common Reference	4!a2!c4!n4!a2! c	M
23A	Identification of the Swap	10a/5a	M
21N	Contract Number Party A	16x	M
21B	Contract Number Party B	16x	O
30T	Termination/Recouping Trade Date	8!n	M
30Q	Termination/Recouping Effective Date	8!n	M
30P	Original Termination Date	8!n	M
30V	Original Effective Date	8!n	M
32B	Party B Current Currency, Notional Amount	3!a15d	M
33B	Party A Current Currency, Notional Amount	3!a15d	M
82a	Party A	A or D	M
87a	Party B	A or D	M
83a	Fund or Beneficiary Customer	A, D, or J	O
22D	Accrual of Interest Specification	4!c	O
32G	Party B New Currency, Notional Amount	3!a15d	O
33E	Party A New Currency, Notional Amount	3!a15d	O
37N	Details of Interest Rate	6*35x	O
29A	Contact Information	4*35x	O



72	Sender to Receiver Information	6*35x	O
----	--------------------------------	-------	---

**Optional Sequence B Fixed Interest Payable by Party B**

Field Tag	Field Name	Format	Mandatory/Optional
15B	New Sequence	Empty field	M
37U	Current Fixed Rate	12d	M
37P	New Fixed Rate	12d	O

**Optional Sequence E Fixed Interest Payable by Party A**

Field Tag	Field Name	Format	Mandatory/Optional
15E	New Sequence	Empty field	M
37U	Current Fixed Rate	12d	M
37P	New Fixed Rate	12d	O

**Optional Sequence J Re-exchange of Principal Payable by Party B**

Field Tag	Field Name	Format	Mandatory/Optional
15J	New Sequence	Empty field	M
30F	Payment Date	8!n	M
32M	Currency, Payment Amount	3!a15d	M
53a	Delivery Agent	A or D	O
56a	Intermediary	A or D	O
86a	Second Intermediary	A or D	O
57a	Receiving Agent	A or D	M

**Optional Sequence K Re-exchange of Principal Payable by Party A**

<b>Field Tag</b>	<b>Field Name</b>	<b>Format</b>	<b>Mandatory/ Optional</b>
15K	New Sequence	Empty field	M
30F	Payment Date	8!n	M
32M	Currency, Payment Amount	3!a15d	M
53a	Delivery Agent	A or D	O
56a	Intermediary	A or D	O
86a	Second Intermediary	A or D	O
57a	Receiving Agent	A or D	M

**Optional Sequence L Fee Payable by Party B**

<b>Field Tag</b>	<b>Field Name</b>	<b>Format</b>	<b>Mandatory/ Optional</b>
15L	New Sequence	Empty field	M
30F	Payment Date	8!n	M
32M	Currency, Payment Amount	3!a15d	M
53a	Delivery Agent	A or D	O
56a	Intermediary	A or D	O
86a	Second Intermediary	A or D	O
57a	Receiving Agent	A or D	M

**Optional Sequence M Fee Payable by Party A**

<b>Field Tag</b>	<b>Field Name</b>	<b>Format</b>	<b>Mandatory/ Optional</b>
15M	New Sequence	Empty field	M
30F	Payment Date	8!n	M
32M	Currency, Payment Amount	3!a15d	M
53a	Delivery Agent	A or D	O
56a	Intermediary	A or D	O
86a	Second Intermediary	A or D	O

57a	Receiving Agent	A or D	M
-----	-----------------	--------	---

## 13.5 Collections and Cash Letters

### 13.5.1 MT 400 Advice of Payment

This message type is typically sent by the collecting bank to the remitting bank. It may also be sent:

- on behalf of the collecting bank by its branch/affiliate bank to the remitting bank or branch/affiliate of that bank
- by a collecting bank to another collecting bank

It is used to advise a payment under a collection or a part thereof and may also be used for the settlement of proceeds. The account relationship between the Sender and the Receiver is used, unless expressly stated otherwise in the message.

This message must never be sent to a bank acting solely as a reimbursement bank. In this case, the appropriate message type is an MT 202 Financial Institution Transfer.

Maximum Length: 2000

#### 13.5.1.1 Format Specifications

Field Tag	Field Name	Format	Mandatory/Optional
20	Sending Bank's TRN	16x	M
21	Related Reference	16x	M
32a	Amount Collected	A, B, or K	M
33A	Proceeds Remitted	6!n3!a15 d	M
52a	Ordering Bank	A or D	O
53a	Sender's Correspondent	A, B, or D	O
54a	Receiver's Correspondent	A, B, or D	O
57a	Account With Bank	A or D	O
58a	Beneficiary Bank	A, B, or D	O
71B	Details of Charges	6*35x	O
72	Sender to Receiver Information	6*35x	O
73	Details of Amounts Added	6*35x	O

### 13.5.2 MT 410 Acknowledgement

This message type is sent by a collecting bank to a remitting bank to acknowledge the receipt of a collection. It may also be sent by a collecting bank to another collecting bank.

Unless otherwise expressly stated, this message type states that the collecting bank intends to act in accordance with the collection instruction.

Maximum Length: 2000

### 13.5.2.1 **Format Specifications**

Field Tag	Field Name	Format	Mandatory/Optional
20	Sending Bank's TRN	16x	M
21	Related Reference	16x	M
32a	Amount Acknowledged	A, B, or K	M
72	Sender to Receiver Information	6*35x	O

### 13.5.3 **MT 412 Advice of Acceptance**

This message type is sent by the collecting bank to the remitting bank. It may also be sent by a collecting bank to another collecting bank.

It is used to inform the Receiver of the acceptance of one or more drafts under one collection instruction.

Maximum Length: 2000

#### 13.5.3.1 **Format Specifications**

Field Tag	Field Name	Format	Mandatory/Optional
20	Sending Bank's TRN	16x	M
21	Related Reference	16x	M
32A	Maturity Date, Currency Code, Amount Accepted	6!n3!a15d	M
72	Sender to Receiver Information	6*35x	O

### 13.5.4 **MT 416 Advice of Non-Payment/Non-Acceptance**

This message type is sent by the collecting bank to the remitting bank.

It may also be sent:

- to the remitting bank via another financial institution
- by a presenting bank to a collecting bank

It is used to advise of non-payment or non-acceptance under a previously received collection or part thereof.

Maximum Length: 10000

### 13.5.4.1 Format Specifications

#### Mandatory Sequence A General Information

Field Tag	Field Name	Format	Mandatory/ Optional
20	Sender's Reference	16x	M
21	Related Reference	16x	M
23E	Advice Type	4!c[/30x]	O
51A	Sending Institution	[/1!a]/[34x] 4!a2!a2!c[3!c]	O
53a	Sender's Correspondent	A or B	O
71F	Sender's Charges	3!a15d	O
77A	Reason for Non-Payment/ Non-Acceptance	20*35x	O

#### Mandatory Repetitive Sequence B Non-Payment/Non-Acceptance Details

Field Tag	Field Name	Format	Mandatory/ Optional
21A	Related Sequence Reference	16x	M
23E	Advice Type	4!c[/30x]	O
21C	Principal's Reference	35x	O
32a	Face Amount of Document(s)	A, B, or K	M
50D	Principal	[/1!a]/ 34x] 4*35x	O
59	Drawee	[/34x] 4*35x	O
71F	Sender's Charges	3!a15d	O
77A	Reason for Non-Payment/ Non-Acceptance	20*35x	O

### 13.5.5 MT 420 Tracer

This message type is sent by the remitting bank to the collecting bank. It may also be sent by a collecting bank to another collecting bank.

It is used to enquire about the fate of documents sent for collection.

Maximum Length: 2000

### 13.5.5.1 Format Specifications

Field Tag	Field Name	Format	Mandatory/Optional
20	Sending Bank's TRN	16x	M
21	Related Reference	16x	M
32a	Amount Traced	A, B, or K	M
30	Date of Collection Instruction	6!n	O
59	Drawee	[/34x] 4*35x	O
72	Sender to Receiver Information	6*35x	O

### 13.5.6 MT 422 Advice of Fate and Request for Instructions

This message type is sent by the collecting bank to the remitting bank.

It may also be sent by a collecting bank to another collecting bank.

It is used to advise the Receiver of the status of collection documents received by the collecting bank. Since an advice of fate generally includes one or more questions or requests, the two functions are included in this one message type.

Maximum Length: 2000

#### 13.5.6.1 Format Specifications

Field Tag	Field Name	Format	Mandatory/Optional
20	Sending Bank's TRN	16x	M
21	Related Reference	16x	M
32a	Amount of Collection	A, B, or K	O
72	Sender to Receiver Information	6*35x	O
75	Queries	6*35x	O
76	Answers	6*35x	O

### 13.5.7 MT 430 Amendment of Instructions

This message type is sent by the remitting bank to the collecting bank. It may also be sent by a collecting bank to another collecting bank.

This message is used to amend instructions contained in the collection.

Maximum Length: 2000

### 13.5.7.1 **Format Specifications**

#### **Mandatory Repetitive Sequence A**

<b>Field Tag</b>	<b>Field Name</b>	<b>Format</b>	<b>Mandatory/Optional</b>
20	Sending Bank's TRN	16x	M
21	Related Reference	16x	M
32a	Existing Maturity Date, Currency Code, Amount	A or K	O
33a	Amended Maturity Date, Currency Code, Amount	A or K	O

#### **Optional Sequence B**

<b>Field Tag</b>	<b>Field Name</b>	<b>Format</b>	<b>Mandatory/Optional</b>
59	Drawee	[/34x] 4*35x	O
72	Sender to Receiver Information	6*35x	O
74	Amendments	6*35x	O

## 13.6 **Securities Markets**

### 13.6.1 **MT 517 Trade Confirmation Affirmation**

This message is sent by an instructing party, e.g. client, or its authorized representative, to a financial institution which had previously sent a trade confirmation/contract note.

This message is used to positively affirm the details of a previously received confirmation/contract note. This message binds the Sender and the Receiver of the message to the trade details contained in the confirmation being affirmed.

This message may be sent directly between the parties to the trade or via an ETC service provider.

Maximum Length: 10000

### 13.6.1.1 Format Specifications

#### Mandatory Sequence A General Information

Field Tag	Field Name	Field Description	Format	Mandatory/Optional
16R		Start of Block	GENL	M
20C	Reference	Sender's Message Reference	:4!c//16x	M
23G		Function of the Message	4!c[/4!c]	M
98a	Date/Time	Preparation Date/Time	A, C, or E	O
95a	Party	(see qualifier description)	P, Q, or R	M
25D	Status Code	Affirmation Status	:4!c/[8c]/4!c	O

#### Mandatory Repetitive Subsequence A1 Linkages

Field Tag	Field Name	Field Description	Format	Mandatory/Optional
16R		Start of Block	LINK	M
13a	Number Identification	Linked Message	A or B	O
20C	Reference	(see qualifier description)	:4!c//16x	M
16S		End of Block	LINK	M

#### End of Subsequence A1 Linkages

Field Tag	Field Name	Field Description	Format	Mandatory/Optional
16S		End of Block	GENL	M

### 13.6.2 MT 518 Market-Side Securities Trade Confirmation

This message is sent by an executing party to its trade counterparty. It is used to confirm the details of a trade.

It may also be used to:

- request the cancellation of a previously sent confirmation
- re-send a confirmation previously sent
- provide a third party with a copy of the message (be it the confirmation or request for cancellation) being sent

This message may include, where necessary, the settlement details of the trade.



The market confirmation may be:

- exchanged directly or via an ETC service provider between two trade counterparties for mutual comparison of the trade details
- sent by one trade party to allege the trade against its counterparty, either directly or via an ETC service provider

Maximum Length: 10000

### 13.6.2.1 Format Specifications

#### Mandatory Sequence A General Information

Field Tag	Field Name	Field Description	Format	Mandatory/Optional
16R		Start of Block	GENL	M
20C	Reference	Sender's Message Reference	:4!c//16x	M
23G		Function of the Message	4!c/[4!c]	M
98a	Date/Time	Preparation Date/Time	A, C, or E	O
22F	Indicator	Trade Transaction Type	:4!c/[8c]/4!c	M

#### Optional Repetitive Subsequence A1 Linkages

Field Tag	Field Name	Field Description	Format	Mandatory/Optional
16R		Start of Block	LINK	M
13a	Number Identification	Linked Message	A or B	O
20C	Reference	(see qualifier description)	:4!c//16x	M
16S		End of Block	LINK	M
16S		End of Block	GENL	M

### Mandatory Sequence B Confirmation Details

Field Tag	Field Name	Field Description	Format	Mandatory/Optional
16R		Start of Block	CONFDET	M
98a	Date/Time	(see qualifier description)	A, B, C, or E	M
90a	Price	Deal Price	A or B	M
92A	Rate	(see qualifier description)	:4!c//[N]15d	O
99A	Number Count	(see qualifier description)	:4!c//[N]3!n	O
94a	Place	(see qualifier description)	B, C, or F	O
19A	Amount	Settlement Amount	:4!c//[N]3!a15d	O
22a	Indicator	(see qualifier description)	F or H	M
11A	Currency	(see qualifier description)	:4!c//3!a	O

### Mandatory Repetitive Subsequence B1 Confirmation Parties

Field Tag	Field Name	Field Description	Format	Mandatory/Optional
16R		Start of Block	CONFPRTY	M
95a	Party	(see qualifier description)	P, Q, R, or S	M
97a	Account	(see qualifier description)	A or B	O
98a	Date/Time	Processing Date/Time	A or C	O
20C	Reference	Processing Reference	:4!c//16x	O
70a	Narrative	(see qualifier description)	C or E	O
22F	Indicator	(see qualifier description)	:4!c/[8c]/4!c	O
s16S		End of Block	CONFPRTY	M

### End of Subsequence B1 Confirmation Parties

Field Tag	Field Name	Field Description	Format	Mandatory /Optional
36B	Quantity of Financial Instrument	Quantity of Financial Instrument Confirmed	:4!c//4!c/15d	M
35B		Identification of the Financial Instrument	[!SIN1!e12!c ] [4*35x]	M

### Optional Subsequence B2 Financial Instrument Attributes

Field Tag	Field Name	Field Description	Format	Mandatory/Optional
16R		Start of Block	FIA	M
94B	Place	Place of Listing	:4!c/[8c]/4!c/[30x]	O
22F	Indicator	(see qualifier description)	:4!c/[8c]/4!c	O
12a	Type of Financial Instrument	(see qualifier description)	A, B, or C	O
11A	Currency	Currency of Denomination	:4!c//3!a	O
98A	Date/Time	(see qualifier description)	:4!c//8!n	O
92A	Rate	(see qualifier description)	:4!c//[N]15d	O
13a	Number Identification	(see qualifier description)	A or B	O
17B	Flag	(see qualifier description)	:4!c//1!a	O
90a	Price	(see qualifier description)	A or B	O
36B	Quantity of Financial Instrument	(see qualifier description)	:4!c//4!c/15d	O
35B		Identification of the Financial Instrument	[!SIN1!e12!c ] [4*35x]	O
70E	Narrative	Financial Instrument Attribute Narrative	:4!c//10*35x	O
16S		End of Block	FIA	M

### End of Subsequence B2 Financial Instrument Attributes

Field Tag	Field Name	Field Description	Format	Mandatory /Optional
13B	Number Identification	Certificate Number	:4!c/[8c]/30x	O
70E	Narrative	(see qualifier description)	:4!c//10*35x	O
16S		End of Block	CONFDET	M

### Optional Sequence C Settlement Details

Field Tag	Field Name	Field Description	Format	Mandatory/Optional
16R		Start of Block	SETDET	M
22F	Indicator	(see qualifier description)	:4!c/[8c]/4!c	M
11A	Currency	(see qualifier description)	:4!c//3!a	O

### Optional Repetitive Subsequence C1 Settlement Parties

Field Tag	Field Name	Field Description	Format	Mandatory/Optional
16R		Start of Block	SETPRTY	M
95a	Party	(see qualifier description)	C, P, Q, R, or S	M
97a	Account	Safekeeping Account	A or B	O
98a	Date/Time	Processing Date/Time	A or C	O
20C	Reference	Processing Reference	:4!c//16x	O
70a	Narrative	(see qualifier description)	C or D	O
16S		End of Block	SETPRTY	M

### Optional Repetitive Subsequence C2 Cash Parties

Field Tag	Field Name	Field Description	Format	Mandatory/Optional
16R		Start of Block	CSHPRTY	M
95a	Party	(see qualifier description)	P, Q, R, or S	M

97A	Account	(see qualifier description)	:4!c//35x	O
98a	Date/Time	Processing Date/Time	A or C	O
20C	Reference	Processing Reference	:4!c//16x	O
70C	Narrative	Party Narrative	:4!c//4*35x	O
16S		End of Block	CSHPRTY	M

#### Optional Repetitive Subsequence C3 Amounts

Field Tag	Field Name	Field Description	Format	Mandatory/Optional
16R		Start of Block	AMT	M
17B	Flag	(see qualifier description)	:4!c//1!a	O
19A	Amount	(see qualifier description)	:4!c//[N]3!a15d	M
98a	Date/Time	Value Date/Time	A or C	O
92B	Rate	Exchange Rate	:4!c//3!a/3!a/15d	O
16S		End of Block	AMT	M

#### End of Subsequence C3 Amounts

Field Tag	Field Name	Field Description	Format	Mandatory/Optional
16S		End of Block	SETDET	M

### Optional Repetitive Sequence D Other Parties

Field Tag	Field Name	Field Description	Format	Mandatory/Optional
16R		Start of Block	OTHRPRTY	M
95a	Party	(see qualifier description)	P, Q, R, or S	M
97a	Account	(see qualifier description)	A or B	O
70C	Narrative	Party Narrative	:4!c//4*35x	O
20C	Reference	Processing Reference	:4!c//16x	O
16S		End of Block	OTHRPRTY	M

### Optional Sequence E Two Leg Transaction Details

Field Tag	Field Name	Field Description	Format	Mandatory /Optional
16R		Start of Block	REPO	M
98a	Date/Time	(see qualifier description)	A, B, or C	O
22F	Indicator	(see qualifier description)	:4!c/[8c]/4!c	O
20C	Reference	(see qualifier description)	:4!c//16x	O
92a	Rate	(see qualifier description)	A, C, or F	O
99B	Number Count	(see qualifier description)	:4!c//3!n	O
19A	Amount	(see qualifier description)	:4!c//[N]3!a15d	O
70C	Narrative	Second Leg Narrative	:4!c//4*35x	O
16S		End of Block	REPO	M

### 13.6.3 MT 540 Receive Free

This message is sent by an account owner to an account servicer (account servicing institution). The account owner may be a global custodian which has an account with its local agent (sub custodian) or an investment management institution or a broker/dealer which has an account with their custodian.

This message is used to instruct a receipt of financial instruments free of payment. It may also be used to request a cancellation or pre-advise an instruction.

Maximum Length: 10000

### 13.6.3.1 Format Specifications

#### Mandatory Sequence A General Information

Field Tag	Field Name	Field Description	Format	Mandatory/Optional
16R		Start of Block	GENL	M
20C	Reference	Sender's Message Reference	:4!c//16x	M
23G		Function of the Message	4!c[/4!c]	M
98a	Date/Time	Preparation Date/Time	A,C or E	O

#### Optional Repetitive Subsequence A1

Field Tag	Field Name	Field Description	Format	Mandatory/Optional
16R		Start of Block	LINK	M
20C	Reference	(see qualifier description)	:4!c//16x	M
36B	Quantity of Financial Instrument	Quantity of Financial Instrument to be Paired-off	:4!c//4!c/15d	O
16S		End of Block	LINK	M
16S		End of Block	GENL	M

### Mandatory Sequence B Trade Details

Field Tag	Field Name	Field Description	Format	Mandatory /Optional
16R		Start of Block	TRADEDET	M
94B	Place	Place of Trade	:4!c/[8c]/4!c/[30x]	O
98a	Date/Time	(see qualifier description)	A, B, C, or E	M
90a	Deal	Deal Price	A or B	O
99A	Number Count	Number of Days Accrued	:4!c/[N]3!n	O
35B		Identification of the Financial Instrument	[ISIN1!e12!c]	M
70E	Narrative	(see qualifier description)	:4!c//10*35x	O
16S		End of Block	TRADEDET	M

### Mandatory Repetitive Sequence C Financial Instrument/Account

Field Tag	Field Name	Field Description	Format	Mandatory /Optional
16R		Start of Block	FIAC	M
36B	Quantity of Financial Instrument	Quantity of Financial Instrument to be settled	:4!c//4!c/15d	M
95a	Party	Account Owner	P or R	O
97a	Account	(see qualifier description)	A or B	M
16S		End of Block	FIAC	M

### Optional Sequence D Two Leg Transaction Details

Field Tag	Field Name	Field Description	Format	Mandatory /Optional
16R		Start of Block	REPO	M
98a	Date/Time	(see qualifier description)	A, B, or C	O
22F	Indicator	(see qualifier description)	:4!c/[8c]/4!c	O
20C	Reference	(see qualifier description)	:4!c//16x	O
92a	Rate	(see qualifier description)	A, C, or F	O



19A	Amount	(see qualifier description)	:4!c//[N]3!a15d	O
70C	Narrative	Second Leg Narrative	:4!c//4*35x	O
16S		End of Block	REPO	M

#### **Mandatory Sequence E Settlement Details**

<b>Field Tag</b>	<b>Field Name</b>	<b>Field Description</b>	<b>Format</b>	<b>Mandatory/Optional</b>
16R		Start of Block	SETDET	M
22F	Indicator	(see qualifier description)	:4!c/[8c]/4!c	M

#### **Mandatory Repetitive Subsequence E1 Settlement Parties**

<b>Field Tag</b>	<b>Field Name</b>	<b>Field Description</b>	<b>Format</b>	<b>Mandatory/Optional</b>
16R		Start of Block	SETPRTY	M
95a	Party	(see qualifier description)	C, P, Q, R, or S	M
97a	Account	Safekeeping Account	A or B	O
16S		End of Block	SETPRTY	M

#### **Optional Repetitive Subsequence E3 Amount**

<b>Field Tag</b>	<b>Field Name</b>	<b>Field Description</b>	<b>Format</b>	<b>Mandatory/Optional</b>
16R		Start of Block	AMT	M
19A	Amount	(see qualifier description)	:4!c//[N]3!a15d	M
16S		End of Block	AMT	M
16S		End of Block	SETDET	M

### **13.6.4 MT 541 Receive Against Payment**

This message is sent by an account owner to an account servicer (account servicing institution). The account owner may be a global custodian which has an account with its local agent (sub custodian) or an investment management institution or a broker/dealer which has an account with their custodian.

This message is used to instruct a receipt of financial instruments against payment. It may also be used to request a cancellation or pre-advise an instruction

Maximum Length: 10000

### 13.6.4.1 Format Specifications

#### Mandatory Sequence A General Information

Field Tag	Field Name	Field Description	Format	Mandatory/Optional
16R		Start of Block	GENL	M
20C	Reference	Sender's Message Reference	:4!c//16x	M
23G		Function of the Message	4!c[/4!c]	M
98a	Date/Time	Preparation Date/Time	A,C or E	O

#### Optional Repetitive Subsequence A1

Field Tag	Field Name	Field Description	Format	Mandatory/Optional
16R		Start of Block	LINK	M
20C	Reference	(see qualifier description)	:4!c//16x	M
36B	Quantity of Financial Instrument	Quantity of Financial Instrument to be Paired-off	:4!c//4!c/15d	O
16S		End of Block	LINK	M
16S		End of Block	GENL	M

#### Mandatory Sequence B Trade Details

Field Tag	Field Name	Field Description	Format	Mandatory/Optional
16R		Start of Block	TRADEDET	M
94B	Place	Place of Trade	:4!c/[8c]/4!c/[30x]	O
98a	Date/Time	(see qualifier description)	A, B, C, or E	M
90a	Deal	Deal Price	A or B	O
99A	Number Count	Number of Days Accrued	:4!c//[N]3!n	O
35B		Identification of the Financial Instrument	[ISIN1!e12!c]	M
70E	Narrative	(see qualifier description)	:4!c//10*35x	O
16S		End of Block	TRADEDET	M

### Mandatory Repetitive Sequence C Financial Instrument/Account

Field Tag	Field Name	Field Description	Format	Mandatory /Optional
16R		Start of Block	FIAC	M
36B	Quantity of Financial Instrument	Quantity of Financial Instrument to be settled	:4!c//4!c/15d	M
95a	Party	Account Owner	P or R	O
97a	Account	(see qualifier description)	A or B	M
16S		End of Block	FIAC	M

### Optional Sequence D Two Leg Transaction Details

Field Tag	Field Name	Field Description	Format	Mandatory/Optional
16R		Start of Block	REPO	M
98a	Date/Time	(see qualifier description)	A, B, or C	O
22F	Indicator	(see qualifier description)	:4!c/[8c]/4!c	O
20C	Reference	(see qualifier description)	:4!c//16x	O
92a	Rate	(see qualifier description)	A, C, or F	O
19A	Amount	(see qualifier description)	:4!c//[N]3!a15d	O
70C	Narrative	Second Leg Narrative	:4!c//4*35x	O
16S		End of Block	REPO	M

### Mandatory Sequence E Settlement Details

Field Tag	Field Name	Field Description	Format	Mandatory/Optional
16R		Start of Block	SETDET	M
22F	Indicator	(see qualifier description)	:4!c/[8c]/4!c	M

### Mandatory Repetitive Subsequence E1 Settlement Parties

Field Tag	Field Name	Field Description	Format	Mandatory /Optional
16R		Start of Block	SETPRTY	M
95a	Party	(see qualifier description)	C, P, Q, R, or S	M
97a	Account	Safekeeping Account	A or B	O
16S		End of Block	SETPRTY	M

### Optional Repetitive Subsequence E3 Amount

Field Tag	Field Name	Field Description	Format	Mandatory /Optional
16R		Start of Block	AMT	M
19A	Amount	(see qualifier description)	:4!c//[N]3!a15d	M
16S		End of Block	AMT	M
16S		End of Block	SETDET	M

### Repetitive Optional Sequence F Other Parties

Field Tag	Field Name	Field Description	Format	Mandatory/Optional
16R		Start of Block	OTHRPRTY	M
95a	Party	(see qualifier description)	C, P, R, Q or S	M
97A	Account	(see qualifier description)	:4c//35x	O
70a	Narrative	(see qualifier description)	E,D or C	O
20C	Reference	Reference	:4c//16x	O
16S		End of Block	OTHRPRTY	M

### 13.6.5 MT 542 Deliver Free

This message is sent by an account owner to an account servicer (account servicing institution). The account owner may be a global custodian which has an account with its local agent (sub custodian) or an investment management institution or a broker/dealer which has an account with their custodian.

This message is used to instruct a delivery of financial instruments free of payment. It may also be used to request a cancellation or pre-advise an instruction.

Maximum Length: 10000

### 13.6.5.1 Format Specifications

#### Mandatory Sequence A General Information

Field Tag	Field Name	Field Description	Format	Mandatory/Optional
16R		Start of Block	GENL	M
20C	Reference	Sender's Message Reference	:4!c//16x	M
23G		Function of the Message	4!c[/4!c]	M
98a	Date/Time	Preparation Date/Time	A, C or E	O
99B	Number Count	(see qualifier description)	:4!c//3!n	O

#### Optional Repetitive Subsequence A1

Field Tag	Field Name	Field Description	Format	Mandatory/Optional
16R		Start of Block	LINK	M
20C	Reference	(see qualifier description)	:4!c//16x	M
16S		End of Block	LINK	M
16S		End of Block	GENL	M

#### Mandatory Sequence B Trade Details

Field Tag	Field Name	Field Description	Format	Mandatory/Optional
16R		Start of Block	TRADEDET	M
94B	Place	Place of Trade	:4!c/[8c]/4!c/[30x]	O
98a	Date/Time	(see qualifier description)	A, B, C, or E	M
90a	Price	Deal Price	A or B	O
35B		Identification of the Financial Instrument	[!SIN1!e12!c]	M
16S		End of Block	TRADEDET	M

### Mandatory Repetitive Sequence C Financial Instrument/Account

Field Tag	Field Name	Field Description	Format	Mandatory /Optional
16R		Start of Block	FIAC	M
36B	Quantity of Financial Instrument	Quantity of Financial Instrument to be Settled	:4!c//4!c/15d	M
95a	Party	Account Owner	P or R	O
97a	Account	(see qualifier description)	A or B	M
94a	Place	Place of Safekeeping	B, C, or F	O
16S		End of Block	FIAC	M

### Optional Sequence D Two Leg Transaction Details

Field Tag	Field Name	Field Description	Format	Mandatory /Optional
16R		Start of Block	REPO	M
98a	Date/Time	Closing Date/Time	A, B, or C	O
22F	Indicator	(see qualifier description)	:4!c/[8c]/4!c	O
20C	Reference	(see qualifier description)	:4!c//16x	O
92a	Rate	(see qualifier description)	A, C, or F	O
99B	Number Count	(see qualifier description)	:4!c//3!n	O
19A	Amount	(see qualifier description)	:4!c//[N]3!a15d	O
70C	Narrative	Second Leg Narrative	:4!c//4*35x	O
16S		End of Block	REPO	M

### Mandatory Sequence E Settlement Details

Field Tag	Field Name	Field Description	Format	Mandatory/Optional
16R		Start of Block	SETDET	M
22F	Indicator	(see qualifier description)	:4!c/[8c]/4!c	M

### Mandatory Repetitive Subsequence E1 Settlement Parties

Field Tag	Field Name	Field Description	Format	Mandatory/Optional
16R		Start of Block	SETPRTY	M
95a	Party	(see qualifier description)	C, P, Q, R, or S	M
16S		End of Block	SETPRTY	M

#### Repetitive Optional Subsequence E2 Cash Parties

Field Tag	Field Name	Field Description	Format	Mandatory/Optional
16R		Start of Block	CSHPRTY	M
95a	Party	(see qualifier description)	P, R, Q or S	M
97A	Account	(see qualifier description)	:4c//35x	O
70a	Narrative	(see qualifier description)	E,D or C	O
16S		End of Block	CSHPRTY	M

#### Optional Repetitive Subsequence E3 Amount

Field Tag	Field Name	Field Description	Format	Mandatory/Optional
16R		Start of Block	AMT	M
19A	Amount	(see qualifier description)	:4!c// [N]3!a15d	M
16S		End of Block	AMT	M
16S		End of Block	SETDET	M

#### Repetitive Optional Sequence F Other Parties

Field Tag	Field Name	Field Description	Format	Mandatory/Optional
16R		Start of Block	OTHRPRTY	M
95a	Party	(see qualifier description)	C, P, R, Q or S	M
97A	Account	(see qualifier description)	:4c//35x	O



70a	Narrative	(see qualifier description)	E,D or C	O
20C	Reference	Reference	:4c//16x	O
16S		End of Block	OTHRPTY	M

### 13.6.6 **MT 543 Deliver Against Payment**

This message is sent by an account owner to an account servicer (account servicing institution). The account owner may be a global custodian which has an account with its local agent (sub custodian) or an investment management institution or a broker/dealer which has an account with their custodian.

This message is used to instruct a delivery of financial instruments against payment. It may also be used to request a cancellation or pre-advise an instruction.

Maximum Length: 10000

#### 13.6.6.1 **Format Specifications**

##### **Mandatory Sequence A General Information**

Field Tag	Field Name	Field Description	Format	Mandatory/Optional
16R		Start of Block	GENL	M
20C	Reference	Sender's Message Reference	:4!c//16x	M
23G		Function of the Message	4!c[4!c]	M
98a	Date/Time	Preparation Date/Time	A, C or E	O
99B	Number Count	(see qualifier description)	:4!c//3!n	O

##### **Optional Repetitive Subsequence A1**

Field Tag	Field Name	Field Description	Format	Mandatory/Optional
16R		Start of Block	LINK	M
16S		End of Block	LINK	M
16S		End of Block	GENL	M

### Mandatory Sequence B Trade Details

Field Tag	Field Name	Field Description	Format	Mandatory/Optional
16R		Start of Block	TRADDET	M
94B	Place	Place of Trade	:4!c/[8c]/4!c/[30x]	O
98a	Date/Time	(see qualifier description)	A, B, C, or E	M
90a	Price	Deal Price	A or B	O
35B		Identification of the Financial Instrument	[!SIN1!e12!c]	M
16S		End of Block	TRADDET	M

### Mandatory Repetitive Sequence C Financial Instrument/Account

Field Tag	Field Name	Field Description	Format	Mandatory/Optional
16R		Start of Block	FIAC	M
36B	Quantity of Financial Instrument	Quantity of Financial Instrument to be Settled	:4!c//4!c/15d	M
95a	Party	Account Owner	P or R	O
97a	Account	(see qualifier description)	A or B	M
16S		End of Block	FIAC	M

### Optional Sequence D Two Leg Transaction Details

Field Tag	Field Name	Field Description	Format	Mandatory/Optional
16R		Start of Block	REPO	M
98a	Date/Time	(see qualifier description)	A, B, or C	O
22F	Indicator	(see qualifier description)	:4!c/[8c]/4!c	O
20C	Reference	(see qualifier description)	:4!c//16x	O
92a	Rate	(see qualifier description)	A, C, or F	O

99B	Number Count	(see qualifier description)	:4!c//3!n	O
19A	Amount	(see qualifier description)	:4!c//[N]3!a15d	O
70C	Narrative	Second Leg Narrative	:4!c//4*35x	O
16S		End of Block	REPO	M

#### Mandatory Sequence E Settlement Details

Field Tag	Field Name	Field Description	Format	Mandatory/Optional
16R		Start of Block	SETDET	M
22F	Indicator	(see qualifier description)	:4!c/[8c]/4!c	M
95a	Party	(see qualifier description)	C, P, Q, R, or S	M

#### Repetitive Optional Subsequence E2 Cash Parties

Field Tag	Field Name	Field Description	Format	Mandatory/Optional
16R		Start of Block	CSHPRTY	M
95a	Party	(see qualifier description)	P, R, Q or S	M
97A	Account	(see qualifier description)	:4c//35x	O
70a	Narrative	(see qualifier description)	E,D or C	O
16S		End of Block	CSHPRTY	M

#### Mandatory Repetitive Subsequence E3 Amount

Field Tag	Field Name	Field Description	Format	Mandatory/Optional
16R		Start of Block	AMT	M
19A	Amount	(see qualifier description)	:4!c//[N]3!a15d	M
16S		End of Block	AMT	M
16S		End of Block	SETDET	M

### Repetitive Optional Sequence F Other Parties

Field Tag	Field Name	Field Description	Format	Mandatory/Optional
16R		Start of Block	OTHRPTY	M
95a	Party	(see qualifier description)	C, P, R, Q or S	M
97A	Account	(see qualifier description)	:4c//35x	O
70a	Narrative	(see qualifier description)	E,D or C	O
20C	Reference	Reference	:4c//16x	O
16S		End of Block	OTHRPTY	M

#### 13.6.7 **MT 592 Request for Cancellation**

This message type is sent by a financial institution to request a second financial institution to consider cancellation of the SWIFT message identified in the request.

If the Receiver of the request for cancellation has already acted on the message for which cancellation is requested, the MT n92 asks for a retransfer, ie, reversal, with the beneficiary's consent.

Maximum Length: 2000

##### 13.6.7.1 **Format Specifications**

Field Tag	Field Name	Format	Mandatory/Optional
20	Transaction Reference Number	16x	M
21	Related Reference	16x	M
11S	MT and Date of the Original Message	3!n 6!n [4!n6!n]	M
79	Narrative Description of the Original Message	35*50x	O
	Copy of at least the Mandatory Fields of the Original Message	Copy of fields	O

#### 13.6.8 **MT 598 Proprietary Message**

This message type is used by financial institutions, with their own offices, and/or with other financial institutions with which they have established bilateral agreements.

It is used as an envelope for a specified message included in it.

It allows for the definition of a unique format for which another message type is not available or applicable.

It also allows financial institutions to use message types which are awaiting live implementation on the SWIFT system.

Maximum Length: 10000

### **13.6.8.1 Format Specifications**

<b>Field Tag</b>	<b>Field Name</b>	<b>Format</b>	<b>Mandatory/Optional</b>
20	Transaction Reference Number	16x	M
12	Sub-Message Type	3!n	M
77E	Proprietary Message	120*78x	M

## **13.7 Treasury Markets - Metals**

### **13.7.1 MT 643 Notice of Drawdown/Renewal**

This message type is sent by the agent of the facility to the providers of funds.

It gives notice of the borrower(s) request for drawdown(s)/renewal(s) on a given date. This request may require the provision of new funds or the re-borrowing of previously disbursed funds.

The MT 643 allows for the handling of drawdown(s)/renewal(s) with differing characteristics. It specifies the currency (ies), amount(s), period(s) and interest rate origin(s).

Maximum Length: 2000

### 13.7.1.1 Format Specifications

#### Mandatory Sequence A Identification of the Facility

Field Tag	Field Name	Format	Mandatory/ Optional
20	Transaction Reference Number	16x	M
21	Related Reference	16x	O
23	Further Identification	16x	M
27	Sequence of Total	1!n/1!n	O
29A	From	4*35x	O
29B	To the Attention of	4*35x	O
88D	Borrower(s)	[/1!a][/ 34x] 4*35x	M
32A	Original Facility Amount	6!n3!a15d	M

#### Optional Repetitive Sequence B Existing Drawings

Field Tag	Field Name	Format	Mandatory/ Optional
26P	Drawing Identification	3!a/4x	M
31F	Drawdown Period	6!n[/6!n][// 35x]	O
32P	Repayment of Principal	6!n3!a15d	O
33a	Interest Amount	P or R	M
71C	Details of Adjustments	6*35x	O
34a	Net Interest Amount	P or R	O
57a	Account With Institution	A, B, or D	O
72	Sender to Receiver Information	6*35x	O

#### Mandatory Repetitive Sequence C New Drawing(s)

Field Tag	Field Name	Format	Mandatory/ Optional
26N	Drawing Identification (New)	3!a/4x	M
32E	Selected Currency	3!a	O

31F	Drawdown Period	6!n[/6!n][//35x]	M
31R	Rate Fixing Date	6!n[/6!n]	O
32B	Amount of Drawdown	3!a15d	M
33B	Receiver's Participation	3!a15d	M
57a	Account With Institution	A, B, or D	O
72	Sender to Receiver Information	6*35x	O

## 13.7.2 **MT 644 Advice of Rate and Amount Fixing**

This message type is sent by the agent of the facility to the providers of funds.

It specifies the interest rate applicable for a drawdown/renewal for a specified interest period, whether the end date of that period is set or not. When applicable, this message type will also set the exchange rate.

Maximum Length: 2000

### 13.7.2.1 **Format Specifications**

#### **Mandatory Sequence A Identification of the Facility**

<b>Field Tag</b>	<b>Field Name</b>	<b>Format</b>	<b>Mandatory/Optional</b>
20	Transaction Reference Number	16x	M
21	Related Reference	16x	O
27	Sequence of Total	1!n/1!n	O
29A	From	4*35x	O
29B	To the Attention of	4*35x	O
88D	Borrower(s)	[/1!a]/34x 4*35x	M
32A	Original Facility Amount	6!n3!a15d	M

### Mandatory Repetitive Sequence B Specification of the Drawing and Related Data

Field Tag	Field Name	Format	Mandatory/ Optional
26a	Drawing Identification	N or P	M
31F	Interest Period	6!n[/6!n][//35x]	M
33B	Receiver's Participation	3!a15d	O
36	Exchange Rate	12d	O
37G	Basis Rate	[N]12d	M
37M	Interest Margin	[N]12d	O
37R	Reserve Interest	[N]12d	O
37a	Total Interest Rate	A, B, C, D, E, or F	O
34a	Differential Amount	P or R	O
57a	Account With Institution	A, B, or D	O
72	Sender to Receiver Information	6*35x	O

#### 13.7.3 **MT 645 Notice of Fee Due**

This message type is sent by the agent of the facility to the signatories thereto or to the parties to the offer.

It specifies flat and variable fees, payable on the same date, which are due to the Receiver.

Maximum Length: 2000



### 13.7.3.1 Format Specifications

#### Mandatory Sequence A Identification of the Facility and Flat Fees

Field Tag	Field Name	Format	Mandatory/Optional
20	Transaction Reference Number	16x	M
21	Related Reference	16x	O
29A	From	4*35x	O
29B	To the Attention of	4*35x	O
88D	Borrower(s)	[/!a]/34x 4*35x	M
32A	Original Facility Amount	6!n3!a15d	M
71B	Flat Fees	6*35x	O

#### Optional Repetitive Sequence B Variable Fees

Field Tag	Field Name	Format	Mandatory/Optional
23	Type of Fee	16x	M
31F	Fee Period	6!n[/6!n][//35x]	M
33B	Computation Base Amount	3!a15d	O
34B	Fee Amount	3!a15d	M
37a	Fee Rate	A, B, C, D, E, or F	O
72	Sender to Receiver Information	6*35x	O

#### Mandatory Sequence C Summation of Fees

Field Tag	Field Name	Format	Mandatory/Optional
71C	Summary of Variable Fees	6*35x	O
33A	Total Fees	6!n3!a15d	M
34A	Amount to be Transferred	6!n3!a15d	O
57a	Account With Institution	A, B, or D	O
72	Sender to Receiver Information	6*35x	O

## 13.7.4 MT 646 Payment of Principal and/or of Interest

This message type is sent by the agent of a facility to the providers of funds.

It provides advice of payments and/or prepayments of principal and/or payment of interest on the same value date, which are not related to any subsequent drawing or renewal. It specifies (to the Receiver) the amount with respect to principal and/or interest.

Maximum Length: 2000

### 13.7.4.1 Format Specifications

#### Mandatory Sequence A Identification of the Facility

Field Tag	Field Name	Format	Mandatory/Optional
20	Transaction Reference Number	16x	M
21	Related Reference	16x	O
23	Further Identification	16x	M
29A	From	4*35x	O
29B	To the Attention of	4*35x	O
88D	Borrower(s)	[/1!a]/[34x] 4*35x	M
32A	Original Facility Amount	6!n3!a15d	M
26P	Drawing Identification	3!a/4x	O

#### Mandatory Repetitive Sequence B Interest Calculation

Field Tag	Field Name	Format	Mandatory/Optional
31F	Interest Period	6!n[/6!n]/[35x]	O
33B	Computation Base Amount	3!a15d	O
34N	Interest Amount	[N]6!n3!a15d	O
37a	Interest Rate	A, B, C, D, E, or F	O
72	Sender to Receiver Information	6*35x	O

### Mandatory Sequence C Principal Payment/Sum of Interest Due

Field Tag	Field Name	Format	Mandatory /Optional
32A	Total Principal Amount Repaid/Prepaid	6!n3!a15d	M
32N	Principal Amount Due to Receiver	[N]6!n3!a15d	O
33N	Gross Interest Amount Due to Receiver	[N]6!n3!a15d	O
34N	Net Interest Amount Due to Receiver	[N]6!n3!a15d	O
34a	Total Amount Transferred	P or R	O
57a	Account With Institution	A, B, or D	O
71C	Details of Adjustments	6*35x	O
72	Sender to Receiver Information	6*35x	O

#### 13.7.5 **MT 649 General Syndicated Facility Message**

This message type may be sent by any financial institution involved in a facility to another financial institution in the facility.

It is used for any communications related to syndicated facilities for which specific message types have not been defined.

This message type may be used throughout the life of the facility.

Maximum Length: 2000

### 13.7.5.1 Format Specifications

Field Tag	Field Name	Format	Mandatory/Optional
20	Transaction Reference Number	16x	M
21	Related Reference	16x	O
27	Sequence of Total	1!n/1!n	O
29A	From	4*35x	O
29B	To the Attention of	4*35x	O
88D	Borrower(s)	[/1!a]/ 34x] 4*35x	M
32a	Facility Amount	A or B	O
79	Narrative	35*50x	M

## 13.8 Documentary Credits and Guarantees

### 13.8.1 MT 700 Issue of a Documentary Credit

This message is sent by the issuing bank to the advising bank.

It is used to indicate the terms and conditions of a documentary credit which has been originated by the Sender (issuing bank).

The system follows the below STP process for incoming MT700 message:

1. When the Advising Bank receives this message, the system compares tag value of 20 in MT700 against the field 'Source Reference' and checks for the existence of the Pre-advice contract.
  - If a contract does not exist, then the system creates a new Export LC contract.
  - If an inactive or unauthorized contract exists, then the system moves MT700 message to a 'Repair' status.
  - If an active and authorized contract exists, then the system amends the operation of the contract from PAD to ADV (advice) or ANC (advice & confirm).
    - If the change is from PAD to ADV, then the system triggers APAD event.
    - If the change is from PAD to ANC, then the system triggers APAC event.
2. The system compares the common fields available in MT705 and MT700 Swift messages, if the check box 'Pre-advice Fields Validation on STP of 700 Required' is checked.
  - If the any of the fields in both the messages are different, then the system moves the contract in 'Repair' status, which can be resolved and processed manually. The system updates 'Mismatch between Pre-advice and Operative LC' as the 'Repair' reason.
  - If any field values are missing in a contract created out of MT705 message, the system updates these values with those available in MT700.

3. The system overwrites all the values of the contract with those available in MT700 message, if the check box 'Pre-advice Fields Validation on STP of 700 Required' is unchecked.

Maximum Length: 10000

### 13.8.1.1 Format Specifications

Field Tag	Field Name	Format	Mandatory /Optional
27	Sequence of Total	1!n/1!n	M
40A	Form of Documentary Credit	24x	M
20	Documentary Credit Number	16x	M
23	Reference to Pre-Advice	16x	O
31C	Date of Issue	6!n	O
40E	Applicable Rules	30x[/35x]	M
31D	Date and Place of Expiry	6!n29x	M
51a	Applicant Bank	A or D	O
50	Applicant	4*35x	M
59	Beneficiary	[/34x] 4*35x	M
32B	Currency Code, Amount	3!a15d	M
39A	Percentage Credit Amount Tolerance	2n/2n	O
39B	Maximum Credit Amount	13x	O
39C	Additional Amounts Covered	4*35x	O
41a	Available With ... By ...	A or D	M
42C	Drafts at ...	3*35x	O
42a	Drawee	A or D	O
42M	Mixed Payment Details	4*35x	O
42P	Deferred Payment Details	4*35x	O
43P	Partial Shipments	1*35x	O
43T	Transshipment	1*35x	O
44A	Place of Taking in Charge/Dispatch from .../Place of Receipt	1*65x	O
44E	Port of Loading/Airport of Departure	1*65x	O
44F	Port of Discharge/Airport of Destination	1*65x	O
44B	Place of Final Destination/For Transportation to .../Place of Delivery	1*65x	O
44C	Latest Date of Shipment	6!n	O
44D	Shipment Period	6*65x	O

45A	Description of Goods and/or Services	100*65x	O
46A	Documents Required	100*65x	O
47A	Additional Conditions	100*65x	O
71B	Charges	6*35x	O
48	Period for Presentation	4*35x	O
49	Confirmation Instructions	7!x	M
53a	Reimbursing Bank	A or D	O
78	Instructions to the Paying/Accepting/Negotiating Bank	12*65x	O
57a	'Advise Through' Bank	A, B, or D	O
72	Sender to Receiver Information	6*35x	O

### 13.8.2 **MT 701 Issue of a Documentary Credit**

This message is sent by the issuing bank to the advising bank.

It is used to indicate the terms and conditions of a documentary credit which has been originated by the Sender (issuing bank).

This message is sent in addition to an MT 700 Issue of a Documentary Credit, when the information in the documentary credit exceeds the maximum input message length of the MT 700.

Maximum Length: 10000

#### 13.8.2.1 **Format Specifications**

Field Tag	Field Name	Format	Mandatory/Optional
27	Sequence of Total	1!n/1!n	M
20	Documentary Credit Number	16x	M
45B	Description of Goods and/or Services	100*65x	O
46B	Documents Required	100*65x	O
47B	Additional Conditions	100*65x	O

### 13.8.3 **MT 705 Pre-Advice of a Documentary Credit**

This message is sent by the issuing bank to the advising bank.

It is a brief advice of a documentary credit, the full details of which will follow.

The pre-advice is not an operative credit instrument. Unless otherwise stated, the issuing bank must forward the operative credit instrument, i.e., MT 700 Issue of a Documentary credit, without delay.

Maximum Length: 2000

When an Advising Bank receives this message, the system creates a Pre-advice Export LC contract automatically through STP processing.



### 13.8.3.1 Format Specifications

Field Tag	Field Name	Format	Mandatory/Optional
40A	Form of Documentary Credit	24x	M
20	Documentary Credit Number	16x	M
31D	Date and Place of Expiry	6!n29x	M
50	Applicant	4*35x	M
59	Beneficiary	[/34x] 4*35x	M
32B	Currency Code, Amount	3!a15d	M
39A	Percentage Credit Amount Tolerance	2n/2n	O
39B	Maximum Credit Amount	13x	O
39C	Additional Amounts Covered	4*35x	O
41a	Available With ... By ...	A or D	O
44A	Place of Taking in Charge/Dispatch from .../Place of Receipt	1*65x	O
44E	Port of Loading/Airport of Departure	1*65x	O
44F	Port of Discharge/Airport of Destination	1*65x	O
44B	Place of Final Destination/For Transportation to .../Place of Delivery	1*65x	O
44C	Latest Date of Shipment	6!n	O
44D	Shipment Period	6*65x	O
45A	Description of Goods and/or Services	100*65x	O
57a	'Advise Through' Bank	A, B, or D	O
79	Narrative	35*50x	O
72	Sender to Receiver Information	6*35x	O

### 13.8.4 MT 707 Amendment to a Documentary Credit

This message informs the Receiver of amendments to the terms and conditions of a documentary credit.

Maximum Length: 10000

### 13.8.4.1 Format Specifications

Field Tag	Field Name	Format	Mandatory/Optional
20	Sender's Reference	16x	M
21	Receiver's Reference	16x	M
23	Issuing Bank's Reference	16x	O
52a	Issuing Bank	A or D	O
31C	Date of Issue	6!n	O
30	Date of Amendment	6!n	O
26E	Number of Amendment	2n	O
59	Beneficiary (before this amendment)	[/34x] 4*35x	M
31E	New Date of Expiry	6!n	O
32B	Increase of Documentary Credit Amount	3!a15d	O
33B	Decrease of Documentary Credit Amount	3!a15d	O
34B	New Documentary Credit Amount After Amendment	3!a15d	O
39A	Percentage Credit Amount Tolerance	2n/2n	O
39B	Maximum Credit Amount	13x	O
39C	Additional Amounts Covered	4*35x	O
44A	Place of Taking in Charge/Dispatch from.../Place of Receipt	65x	O
44E	Port of Loading/Airport of Departure	65x	O
44F	Port of Discharge/Airport of Destination	65x	O
44B	Place of Final Destination/For Transportation to.../Place of Delivery	65x	O
44C	Latest Date of Shipment	6!n	O
44D	Shipment Period	6*65x	O
79	Narrative	35*50x	O
72	Sender to Receiver Information	6*35x	O

---

#### Note

Field 72 will be split into two if the total length of the field exceeds 1750 characters.

---

### **13.8.5 MT 710 Advice of a Third Bank's or a Non-Bank's Documentary Credit**

This message is sent by an advising bank, which has received a documentary credit from the issuing bank or the non-bank issuer, to the bank advising the beneficiary or another advising bank.

It is used to advise the Receiver about the terms and conditions of a documentary credit.

Maximum Length: 10000

### 13.8.5.1 Format Specifications

Field Tag	Field Name	Format	Mandatory /Optional
27	Sequence of Total	1!n/1!n	M
40B	Form of Documentary Credit	24x 24x	M
20	Sender's Reference	16x	M
21	Documentary Credit Number	16x	M
23	Reference to Pre-Advice	16x	O
31C	Date of Issue	6!n	M
40E	Applicable Rules	30x[/35x]	M
31D	Date and Place of Expiry	6!n29x	M
52a	Issuing Bank	A or D	O
50B	Non-Bank Issuer	4*35x	O
51a	Applicant Bank	A or D	O
50	Applicant	4*35x	M
59	Beneficiary	[/34x] 4*35x	M
32B	Currency Code, Amount	3!a15d	M
39A	Percentage Credit Amount Tolerance	2n/2n	O
39B	Maximum Credit Amount	13x	O
39C	Additional Amounts Covered	4*35x	O
41a	Available With ... By ...	A or D	M
42C	Drafts at ...	3*35x	O
42a	Drawee	A or D	O
42M	Mixed Payment Details	4*35x	O
42P	Deferred Payment Details	4*35x	O
43P	Partial Shipments	1*35x	O
43T	Transshipment	1*35x	O
44A	Place of Taking in Charge/Dispatch from .../Place of Receipt	1*65x	O
44E	Port of Loading/Airport of Departure	1*65x	O
44F	Port of Discharge/Airport of Destination	1*65x	O

44B	Place of Final Destination/For Transportation to .../Place of Delivery	1*65x	O
44C	Latest Date of Shipment	6!n	O
44D	Shipment Period	6*65x	O
45A	Description of Goods and/or Services	100*65x	O
46A	Documents Required	100*65x	O
47A	Additional Conditions	100*65x	O
71B	Charges	6*35x	O
48	Period for Presentation	4*35x	O
49	Confirmation Instructions	7!x	M
53a	Reimbursing Bank	A or D	O
78	Instructions to the Paying/Accepting/Negotiating Bank	12*65x	O
57a	'Advise Through' Bank	A, B, or D	O
72	Sender to Receiver Information	6*35x	O

### **13.8.6 MT 720 Transfer of a Documentary Credit**

When a beneficiary has requested the transfer of a documentary credit - originally issued by a bank or a non-bank - to a second beneficiary, this message is sent by the bank authorized to advise the transfer of the documentary credit, to the bank advising the second beneficiary.

It is used to advise the Receiver about the terms and conditions of the transferred documentary credit, or part thereof.

Maximum Length: 10000

### 13.8.6.1 Format Specifications

Field Tag	Field Name	Format	Mandatory/Optional
27	Sequence of Total	1!n/1!n	M
40B	Form of Documentary Credit	24x 24x	M
20	Transferring Bank's Reference	16x	M
21	Documentary Credit Number	16x	M
31C	Date of Issue	6!n	O
40E	Applicable Rules	30x[/35x]	M
31D	Date and Place of Expiry	6!n29x	M
52a	Issuing Bank of the Original Documentary Credit	A or D	O
50B	Non-Bank Issuer of the Original Documentary Credit	4*35x	O
50	First Beneficiary	4*35x	M
59	Second Beneficiary	[/34x] 4*35x	M
32B	Currency Code, Amount	3!a15d	M
39A	Percentage Credit Amount Tolerance	2n/2n	O
39B	Maximum Credit Amount	13x	O
39C	Additional Amounts Covered	4*35x	O
41a	Available With ... By ...	A or D	M
42C	Drafts at ...	3*35x	O
42a	Drawee	A or D	O
42M	Mixed Payment Details	4*35x	O
42P	Deferred Payment Details	4*35x	O
43P	Partial Shipments	1*35x	O
43T	Transshipment	1*35x	O
44A	Place of Taking in Charge/Dispatch from .../Place of Receipt	1*65x	O
44E	Port of Loading/Airport of Departure	1*65x	O
44F	Port of Discharge/Airport of Destination	1*65x	O

44B	Place of Final Destination/For Transportation to .../Place of Delivery	1*65x	O
44C	Latest Date of Shipment	6!n	O
44D	Shipment Period	6*65x	O
45A	Description of Goods and/or Services	100*65x	O
46A	Documents Required	100*65x	O
47A	Additional Conditions	100*65x	O
71B	Charges	6*35x	O
48	Period for Presentation	4*35x	O
49	Confirmation Instructions	7!x	M
78	Instructions to the Paying/Accepting/ Negotiating Bank	12*65x	O
57a	'Advise Through' Bank	A, B, or D	O
72	Sender to Receiver Information	6*35x	O

### 13.8.7 **MT 730 Acknowledgement**

This message is used to acknowledge receipt of any documentary credit message. When applicable, it may also explicitly indicate that the message has been forwarded according to instructions.

This message type may also be used:

- to account for bank charges
- to advise of acceptance or rejection of an amendment of a credit

Maximum Length: 2000

### 13.8.7.1 Format Specifications

Field Tag	Field Name	Format	Mandatory/Optional
20	Sender's Reference	16x	M
21	Receiver's Reference	16x	M
25	Account Identification	35x	O
30	Date of Message Being Acknowledged	6!n	M
32a	Amount of Charges	B or D	O
57a	Account With Bank	A or D	O
71B	Charges	6*35x	O
72	Sender to Receiver Information	6*35x	O

### 13.8.8 MT 732 Advice of Discharge

This message is typically sent by the issuing bank to the paying/negotiating or accepting bank. It may also be sent by the paying/accepting/negotiating bank to the bank from which it has received documents.

It is used to advise the Receiver that the documents received with discrepancies have been taken up.

Maximum Length: 2000

#### 13.8.8.1 Format Specifications

Field Tag	Field Name	Format	Mandatory/Optional
20	Sender's TRN	16x	M
21	Presenting Bank's Reference	16x	M
30	Date of Advice of Payment/Acceptance/Negotiation	6!n	M
32B	Amount of Utilization	3!a15d	M
72	Sender to Receiver Information	6*35x	O

### 13.8.9 MT 734 Advice of Refusal

Advises the refusal of documents that are not in accordance with the terms and conditions of a documentary credit

Maximum Length: 10000



### 13.8.9.1 Format Specifications

Field Tag	Field Name	Format	Mandatory/Optional
20	Sender's TRN	16x	M
21	Presenting Bank's Reference	16x	M
32A	Date and Amount of Utilization	6!n3!a15d	M
73	Charges Claimed	6*35x	O
33a	Total Amount Claimed	A or B	O
57a	Account With Bank	A, B or D	O
72	Sender to Receiver Information	6*35x	O
77J	Discrepancies	70*50x	M
77B	Disposal of Documents	3*35x	M

---

#### Note

Field 77B will have the following format for line 1 –3:

- Line 1: /8c/[additional information]
- Line 2-6: [//add'l information]

The following codes are supported for field 77B:

- HOLD
  - RETURN
- 

### 13.8.10 MT 740 Authorization to Reimburse

This message is sent by the issuing bank to the reimbursing bank.

It is used to request the Receiver to honour claims for reimbursement of payment(s) or negotiation(s) under a documentary credit.

The MT 740 authorizes the reimbursing bank to debit the account of the Sender, or one of the Sender's branches if so indicated, for reimbursements effected in accordance with the instructions in the MT 740.

Maximum Length: 2000

### 13.8.10.1 Format Specifications

Field Tag	Field Name	Format	Mandatory/Optional
20	Documentary Credit Number	16x	M
25	Account Identification	35x	O
40F	Applicable Rules	30x	M
31D	Date and Place of Expiry	6!n29x	O
58a	Negotiating Bank	A or D	O
59	Beneficiary	[/34x] 4*35x	O
32B	Credit Amount	3!a15d	M
39A	Percentage Credit Amount Tolerance	2n/2n	O
39B	Maximum Credit Amount	13x	O
39C	Additional Amounts Covered	4*35x	O
41a	Available With ... By ...	A or D	M
42C	Drafts at ...	3*35x	O
42a	Drawee	A or D	O
42M	Mixed Payment Details	4*35x	O
42P	Deferred Payment Details	4*35x	O
71A	Reimbursing Bank's Charges	3!a	O
71B	Other Charges	6*35x	O
72	Sender to Receiver Information	6*35x	O

### 13.8.11 MT 742 Reimbursement Claim

This message is sent by the paying/negotiating bank to the bank authorized to reimburse the Sender for its payments/negotiations.

It is used to claim reimbursement of payment(s) or negotiation(s) under a documentary credit, as relevant to the reimbursing bank.

Maximum Length: 2000

### 13.8.11.1 Format Specifications

Field Tag	Field Name	Format	Mandatory/Optional
20	Claiming Bank's Reference	16x	M
21	Documentary Credit Number	16x	M
31C	Date of Issue	6!n	O
52a	Issuing Bank	A or D	M
32B	Principal Amount Claimed	3!a15d	M
33B	Additional Amount Claimed as Allowed for in Excess of Principal Amount	3!a15d	O
71B	Charges	6*35x	O
34a	Total Amount Claimed	A or B	M
57a	Account With Bank	A, B, or D	O
58a	Beneficiary Bank	A or D	O
72	Sender to Receiver Information	6*35x	O

### 13.8.12 MT 747 Amendment to an Authorization to Reimburse

This message is sent by the bank which has issued an authorization to reimburse (issuing bank) to the reimbursing bank.

It is used to inform the Receiver about amendments to the terms and conditions of the credit relevant to the authorization to reimburse.

The amendment is to be considered as part of the authorization to reimburse.

Maximum Length: 2000

### 13.8.12.1 Format Specifications

Field Tag	Field Name	Format	Mandatory/Optional
20	Documentary Credit Number	16x	M
21	Reimbursing Bank's Reference	16x	O
30	Date of the Original Authorisation to Reimburse	6!n	M
31E	New Date of Expiry	6!n	O
32B	Increase of Documentary Credit Amount	3!a15d	O
33B	Decrease of Documentary Credit Amount	3!a15d	O
34B	New Documentary Credit Amount After Amendment	3!a15d	O
39A	Percentage Credit Amount Tolerance	2n/2n	O
39B	Maximum Credit Amount	13x	O
39C	Additional Amounts Covered	4*35x	O
72	Sender to Receiver Information	6*35x	O
77A	Narrative	20*35x	O

### 13.8.13 MT 750 Advice of Discrepancy

Advise of discrepancies and requests authorization to honour documents presented that are not in accordance with the terms and conditions of the documentary credit

Maximum Length: 10000

### 13.8.13.1 Format Specifications

Field Tag	Field Name	Format	Mandatory/Optional
20	Presenting Bank's Reference	16x	M
21	Related Reference	16x	M
32B	Principal Amount	3!a15d	M
33B	Additional Amount	3!a15d	O
71B	Charges to be Deducted	6*35x	O
73	Charges to be Added	6*35x	O
34B	Total Amount to be Paid	3!a15d	O
57a	Account With Bank	A, B or D	O
72	Sender to Receiver Information	6*35x	O
77J	Discrepancies	70*50x	M

### 13.8.14 MT 752 Authorization to Pay, Accept or Negotiate

This message is sent by the issuing bank, or the nominated bank if so authorized by the issuing bank, to a paying/accepting/negotiating bank in response to a request for authorization to pay/accept/negotiate/incur a deferred payment undertaking previously requested via an MT 750 Advice of Discrepancy or otherwise.

It is used to advise the Receiver that documents may be taken up, notwithstanding the discrepancies, provided they are otherwise in order.

Maximum Length: 2000

### 13.8.14.1 Format Specifications

Field Tag	Field Name	Format	Mandatory/Optional
20	Documentary Credit Number	16x	M
21	Presenting Bank's Reference	16x	M
23	Further Identification	16x	M
30	Date of Advice of Discrepancy or Mailing	6!n	M
32B	Total Amount Advised	3!a15d	O
71B	Charges Deducted	6*35x	O
33a	Net Amount	A or B	O
53a	Sender's Correspondent	A, B, or D	O
54a	Receiver's Correspondent	A, B, or D	O
72	Sender to Receiver Information	6*35x	O

### 13.8.15 MT 754 Advice of Payment/Acceptance/Negotiation

This message is sent by the paying, accepting or negotiating bank, or the bank incurring a deferred payment undertaking, to the issuing bank. It may also be sent by the bank to which documents have been presented to a bank that has been nominated to pay/accept.

It is used to advise the Receiver that documents were presented in accordance with the credit terms and are being forwarded as instructed.

The MT 754 may also be used:

- for the settlement of the payment/negotiation
- as a pre-notification of a reimbursement claim from the claiming bank to the issuing bank
- as a pre-debit notification from the claiming bank to the issuing bank

---

#### **Note**

Where a pre-debit notification from the reimbursing bank to the issuing bank is required, banks should use the MT 799 Free Format message, specifying the future date of debit.

---

Maximum Length: 2000

### 13.8.15.1 Format Specifications

Field Tag	Field Name	Format	Mandatory/Optional
20	Sender's Reference	16x	M
21	Related Reference	16x	M
32a	Principal Amount Paid/Accepted/ Negotiated	A or B	M
33B	Additional Amounts	3!a15d	O
71B	Charges Deducted	6*35x	O
73	Charges Added	6*35x	O
34a	Total Amount Claimed	A or B	O
53a	Reimbursing Bank	A, B, or D	O
57a	Account With Bank	A, B, or D	O
58a	Beneficiary Bank	A or D	O
72	Sender to Receiver Information	6*35x	O
77A	Narrative	20*35x	O

### 13.8.16 MT 756 Advice of Reimbursement or Payment

This message is sent by the issuing bank to the bank from which it has received documents or by the reimbursing bank to the bank from which it has received a reimbursement claim. It may also be sent by the bank nominated to pay/accept/negotiate/incur a deferred payment undertaking to the bank from which it has received documents.

It is used to advise the Receiver about reimbursement or payment, to that bank, for a drawing under a documentary credit for which no specific reimbursement instructions or payment provisions were provided.

The account relationship between the Sender and the Receiver is used unless otherwise expressly stated in the message.

Maximum Length: 2000

### 13.8.16.1 Format Specifications

Field Tag	Field Name	Format	Mandatory/Optional
20	Sender's Reference	16x	M
21	Presenting Bank's Reference	16x	M
32B	Total Amount Claimed	3!a15d	M
33A	Amount Reimbursed or Paid	6!n3!a15d	M
53a	Sender's Correspondent	A, B, or D	O
54a	Receiver's Correspondent	A, B, or D	O
72	Sender to Receiver Information	6*35x	O

### 13.8.17 MT 760 (Guarantee / Standby Letter Of Credit)

Issues or requests the issue of a guarantee or Standby LC

Maximum Length: 10000

#### 13.8.17.1 Format Specifications

Field Tag	Field Name	Format	Mandatory/Optional
27	Sequence of Total	1n/1n	M
20	Transaction Reference Number	16x	M
23	Further Identification	16x	M
30	Date	6!n	O
40C	Applicable Rules	4!a[/35x]	M
77C	Details of Guarantee	150*65x	M
72	Sender to Receiver Information	6*35x	O

---

#### Note

- The ISPR (The guarantee is subject to International Standby Practices) additional type codes are allowed for field 40 C
  - The URCG (The guarantee is subject to the ICC Uniform Rules for Demand Guarantees) type codes are disallowed for field 40 C
-



### 13.8.18 **MT 767 Guarantee / Standby Letter of Credit Amendment**

This message is sent by a bank which has issued a guarantee to the bank to which the guarantee was issued. It may also be sent by a bank which has requested the issuance of a guarantee to the bank to which the request for a guarantee was sent.

It is used to amend or request the amendment of the guarantee.

---

**Note**

This message may also be used for Standby Letters of Credit.

---

Maximum Length: 10000

#### 13.8.18.1 **Format Specifications**

Field Tag	Field Name	Format	Mandatory/Optional
27	Sequence of Total	1!n/1!n	M
20	Transaction Reference Number	16x	M
21	Related Reference	16x	M
23	Further Identification	16x	M
30	Date	6!n	O
26E	Number of Amendment	2n	O
31C	Date of Issue or Request to Issue	6!n	M
77C	Amendment Details	150*65 x	M
72	Sender to Receiver Information	6*35x	O

### 13.8.19 **MT 768 Acknowledgement of a Guarantee / Standby Message**

This message type is sent by a bank which has received a guarantee to the bank which issued the guarantee or an amendment thereto. It may also be sent by a bank which has been requested to issue a guarantee to the bank which requested the guarantee or an amendment thereto.

It is used to acknowledge receipt of any message relating to a guarantee and, where applicable, to indicate that action has been taken according to the instructions. This message may also be used for Standby Letters of Credit.

The Sender's charges may also be accounted for in this message.

Maximum Length: 2000

### 13.8.19.1 Format Specifications

Field Tag	Field Name	Format	Mandatory/Optional
20	Transaction Reference Number	16x	M
21	Related Reference	16x	M
25	Account Identification	35x	O
30	Date of Message Being Acknowledged	6!n	M
32a	Amount of Charges	B or D	O
57a	Account With Bank	A, B, or D	O
71B	Details of Charges	6*35x	O
72	Sender to Receiver Information	6*35x	O

## 13.9 Cash Management and Customer Status

### 13.9.1 MT 900 Confirmation of Debit

This message type is sent by an account servicing institution to an account owner.

It is used to notify the account owner of an entry which has been debited to its account. The entry will be further confirmed by statement.

Maximum Length: 2000

#### 13.9.1.1 Format Specifications

Field Tag	Field Name	Format	Mandatory/Optional
20	Transaction Reference Number	16x	M
21	Related Reference	16x	M
25	Account Identification	35x	M
32A	Value Date, Currency Code, Amount	6!n3!a15d	M
52a	Ordering Institution	A or D	O
72	Sender to Receiver Information	6*35x	O

### 13.9.2 MT 910 Confirmation of Credit

This message is sent by an account servicing institution to an account owner.

It is used to notify the account owner of an entry which has been credited to its account. The entry will be further confirmed by statement.

Maximum Length: 2000

### 13.9.2.1 Format Specifications

Field Tag	Field Name	Format	Mandatory/Optional
20	Transaction Reference Number	16x	M
21	Related Reference	16x	M
25	Account Identification	35x	M
32A	Value Date, Currency Code, Amount	6!n3!a15d	M
50a	Ordering Customer	A, F, or K	O
52a	Ordering Institution	A or D	O
56a	Intermediary	A or D	O
72	Sender to Receiver Information	6*35x	O

### 13.9.3 MT 920 Request Message

An account owner or a party acting on the account owner's behalf to one of the account owner's account servicing institutions sends this message. It is used to request the account servicing institution to transmit one or more reports (for example, a statement) containing the requested information for the account(s) identified in the message

Maximum Length: 2000

#### 13.9.3.1 Format Specifications

Field Tag	Field Name	Format	Mandatory/Optional
20	Transaction Reference Number	16x	M
12	Message Requested	3!n	M
25	Account Identification	35x	M
34F	Floor Limit Indicator	3!a[1a]15d	O

### 13.9.4 MT 940 Customer Statement Message

This message type is sent by an account servicing institution (reporting institution) to a financial institution (concentrating institution) which has been authorized by the account owner to receive it.

It is used to transmit detailed information about all entries booked to the account.

Maximum Length: 2000

### 13.9.4.1 Format Specifications

Field Tag	Field Name	Format	Mandatory/Optional
20	Transaction Reference Number	16x	M
21	Related Reference	16x	O
25	Account Identification	35x	M
28C	Statement Number/Sequence Number	5n[/5n]	M
60a	Opening Balance	F or M	M
61	Statement Line	6!n[4!n]2a[1!a]15d 1!a3!c16x[//16x] [34x]	O
86	Information to Account Owner	6*65x	O
62a	Closing Balance (Booked Funds)	F or M	M
64	Closing Available Balance (Available Funds)	1!a6!n3!a15d	O
65	Forward Available Balance	1!a6!n3!a15d	O
86	Information to Account Owner	6*65x	O

### 13.9.5 MT 950 Statement Message

This message type is sent by an account servicing institution to an account owner. It is used to transmit detailed information about all entries, whether or not caused by a SWIFT message, booked to the account.

Maximum Length: 2000

### 13.9.5.1 Format Specifications

Field Tag	Field Name	Format	Mandatory/Optional
20	Transaction Reference Number	16x	M
25	Account Identification	35x	M
28C	Statement Number/ Sequence Number	5n[/5n]	M
60a	Opening Balance	F or M	M
61	Statement Line	6!n[4!n]2a[1!a]15d1!a3! c16x[//16x] [34x]	O
62a	Closing Balance (Booked Funds)	F or M	M
64	Closing Available Balance (Available Funds)	1!a6!n3!a15d	O

## 14.1 Introduction

All activities that are performed in the Messaging System (MS) module are recorded. The inputs you have made at different stages are pieced together and can be extracted in the form of meaningful reports as and when you may require them. The various report programs and reporting features available under the Messaging System module are explained in this chapter.

You can generate the following reports for the Messaging System module:

- SMS Log Report
- Successful Messages Report
- Unsuccessful Messages Report

## 14.2 SMS Log Report

You can select the following options based on which the report can be generated.

- You can specify the operation date for which the report has to be generated.
- You can generate the report for specific User ID
- You can also generate the report based on the operation

To invoke the screen 'Security Management System Log Report', type 'MSRMSRPT' in the field at the top right corner of the Application tool bar and clicking on the adjoining arrow button. The screen 'Security Management System Log Report' is displayed below:

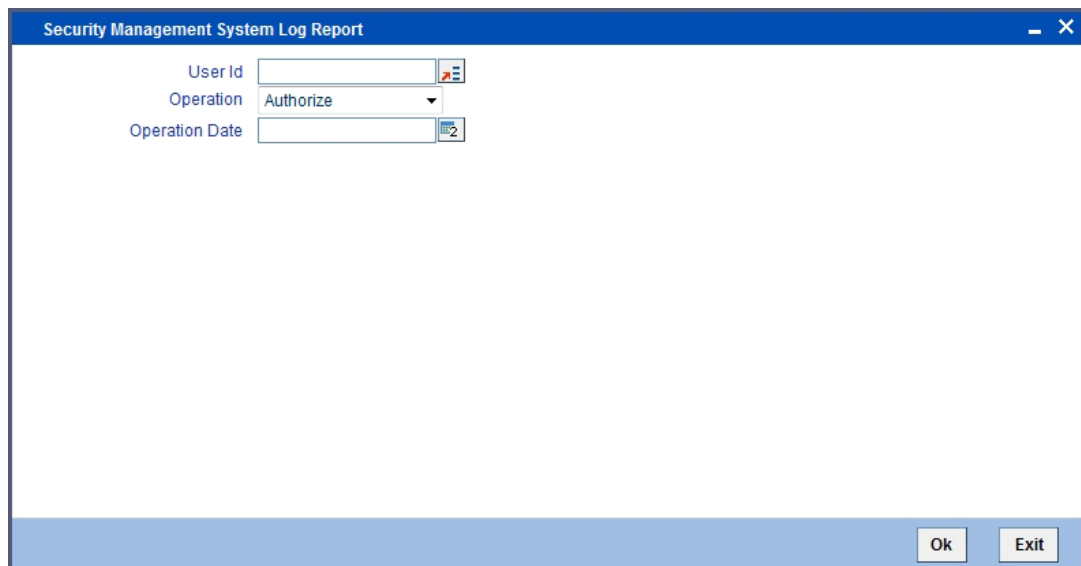

The screenshot shows a dialog box titled "Security Management System Log Report". It contains three input fields: "User Id" (a text box with a search icon), "Operation" (a dropdown menu currently showing "Authorize"), and "Operation Date" (a date picker). At the bottom right, there are "Ok" and "Exit" buttons.

You can specify the following parameters:

### **User ID**

Specify valid User ID for which you want to generate the report from the adjoining option list.

### **Operation**

Select valid mode of operation for which you want to generate the report from the adjoining drop-down list.

### Operation Date

Select operation date of the selected operation for which you want to generate the report from the adjoining calendar.

## 14.2.1 Contents of Report

The parameters specified while generating the report are printed at the beginning of the report. The contents of the SMS Log Report have been discussed under the following heads:

### 14.2.1.1 Header

The Header carries the title of the Report, information on the branch code, the branch date, the user id, the module name, the date and time at which the report was generated and the page number of the report.

Body Branch	This is the branch code
Document Reference	This is the document control number generated by the system.
User ID	This is the user ID.
Date	This is the date of the log.
Operation	This is the type of operation.
Receiver	This is the name of the receiver.
Currency	This is the currency.
Amount	This is the amount.
Terminal ID	This is the terminal ID.

## 14.3 Unsuccessful Messages Report

To invoke the 'Upload Exception' screen, type 'MSRPLEXP' in the field at the top right corner of the Application tool bar and clicking on the adjoining arrow button. The screen is displayed below:

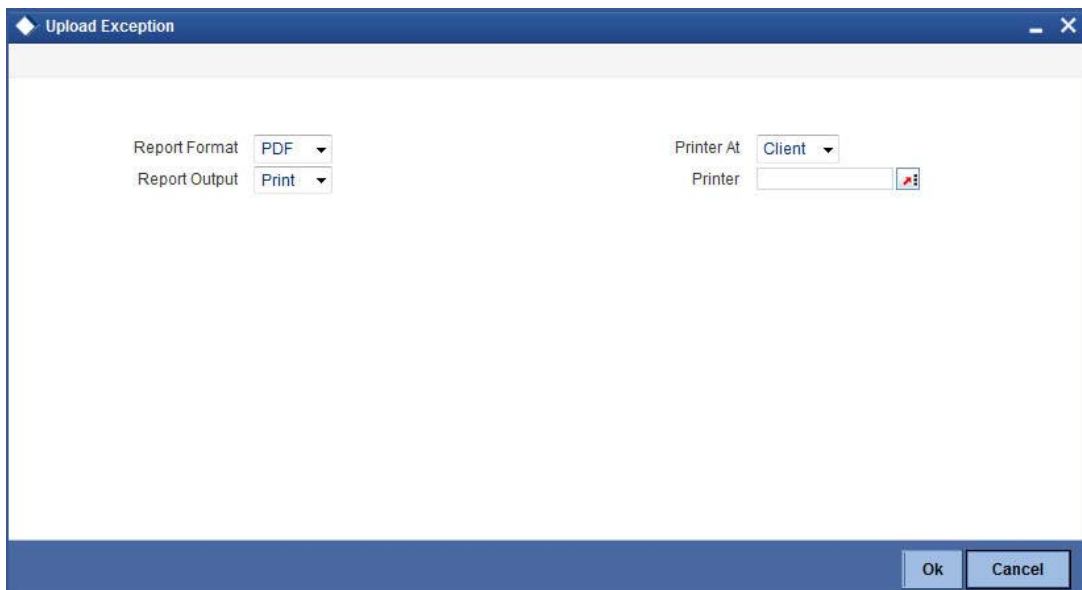

The screenshot shows a dialog box titled "Upload Exception". It contains the following controls:

- Report Format: PDF
- Report Output: Print
- Printer At: Client
- Printer: (empty text field)

At the bottom right, there are "Ok" and "Cancel" buttons.

### 14.3.1 Contents of Report

The contents of the Unsuccessful Messages Report have been discussed under the following heads:

#### 14.3.1.1 Header

The Header carries the title of the Report, information on the branch code, the branch date, the user id, the module name, the date and time at which the report was generated and the page number of the report.

#### 14.3.1.2 Body

##### **Reference Number**

This is the reference number of the repair.

##### **Repair Reason**

This is the reason for the repair.

## 14.4 Successful Messages Report

You can generate Successful Messages report using 'Successful Messages Report' screen. To invoke the screen, type 'MSRPLSUX' in the field at the top right corner of the Application tool bar and clicking on the adjoining arrow button. The screen is displayed below:

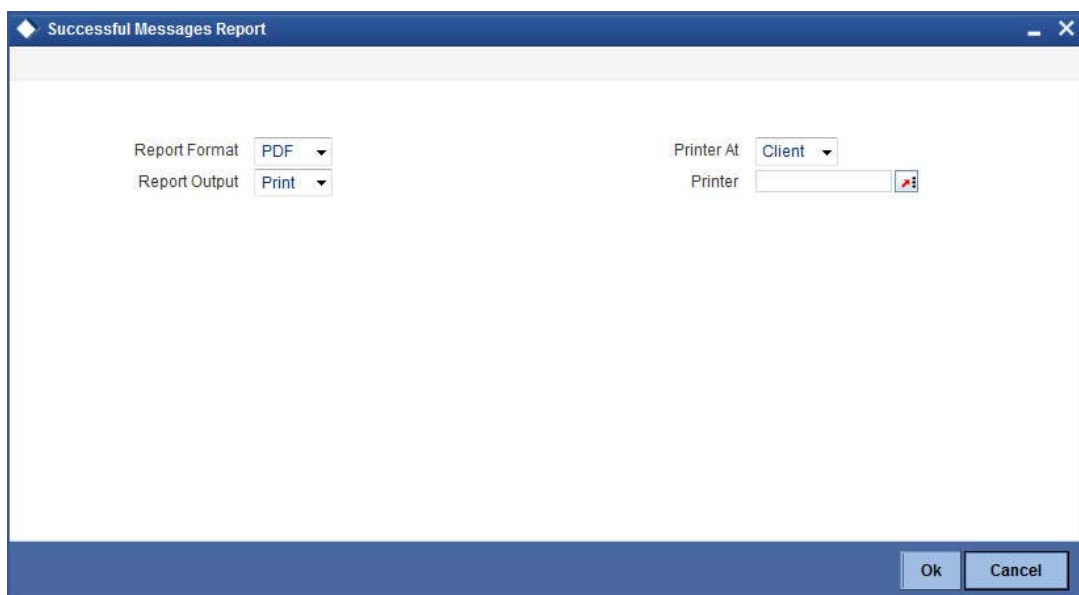

### 14.4.1 Contents of Report

The contents of the Successful Messages Report have been discussed under the following heads:

#### 14.4.1.1 Header

The Header carries the title of the report, information on the branch code, the branch date, the user id, the module name, the date and time at which the report was generated and the page number of the report.



### 14.4.1.2 Body

#### **External Reference**

This is the external reference number of the contract.

#### **FLEXCUBE Reference Number**

This is the Oracle FLEXCUBE number.

#### **Contract Status**

This is the contract status of the contract.

#### **Auth Status**

This is the authorization status of the contract.

#### **Maker ID**

This is the ID of the maker.

#### **Maker Date Stamp**

This is the date on which the maker created the contract.

#### **Checker ID**

This is the ID of the checker.

#### **Checker Date Stamp**

This is the date on which the checker verified the contract.

## 14.5 Daily Swift Message Status Report

You can invoke 'Daily Swift Message Status Report' screen by typing 'MSRDSWFT' in the field at the top right corner of the Application tool bar and click the adjoining arrow button. The system will display 'Print Options' screen. Set your preferences as to printing the report and click 'OK' button.

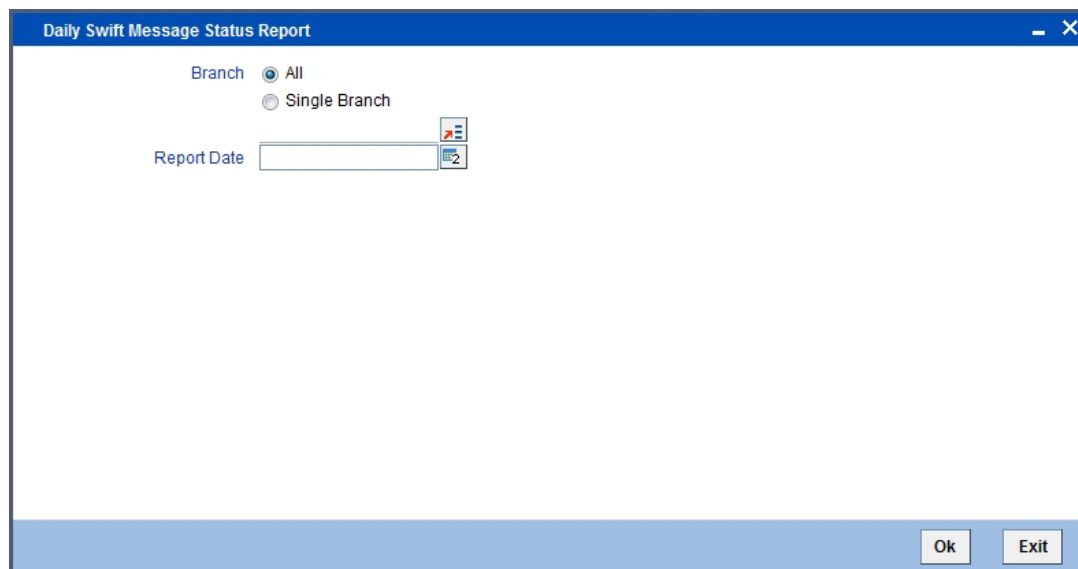

The screenshot shows a dialog box titled "Daily Swift Message Status Report". It features a "Branch" section with two radio button options: "All" (which is selected) and "Single Branch". Below this is a "Report Date" field with a text input box and a calendar icon to its right. At the bottom right of the dialog, there are two buttons: "Ok" and "Exit".

#### **Branch Code**

You can generate this report for all the branches or a single branch alone. You can indicate the branch for which the report is being generated using the following options:

- All – If you choose this, the system will generate the report for all the branches.

- Single – If you choose this, you need to specify the branch code for which the report should be generated. The option list displays all valid branch codes maintained in the system. Choose the appropriate one.

### **Report Date**

Specify the report date from the adjoining calendar list.

## **14.5.1 Contents of the Report**

The parameters specified while generating the report are printed at the beginning of the report. Other content displayed in the report is as follows:

### **Header**

The 'Header' carries the title of the report, branch code, branch date, user ID, module from which the report has been generated, date and time at which the report has been generated and the page number of the report.

### **Body**

You can find the following details in the body of the report:

Date of Receiving	Indicates the date of receiving
Value Date	Indicates the value date
Remitting Bank	Indicates the name of remitting bank
Branch Name	Indicates the name of the branch
Amount of Remittance	Indicates the amount of remittance
Currency of Remittance	Indicates the currency of remittance
Serial Numbers	Indicates the serial numbers
Contract Reference	Indicates the contract reference
Sender	Indicates the name of the sender

## **14.6 Statement Message Status Report**

You can invoke 'Statement Message Status Report' screen by typing 'MSRSTMSG' in the field at the top right corner of the Application tool bar and click the adjoining arrow button. The

system will display 'Print Options' screen. Set your preferences as to printing the report and click 'OK' button.

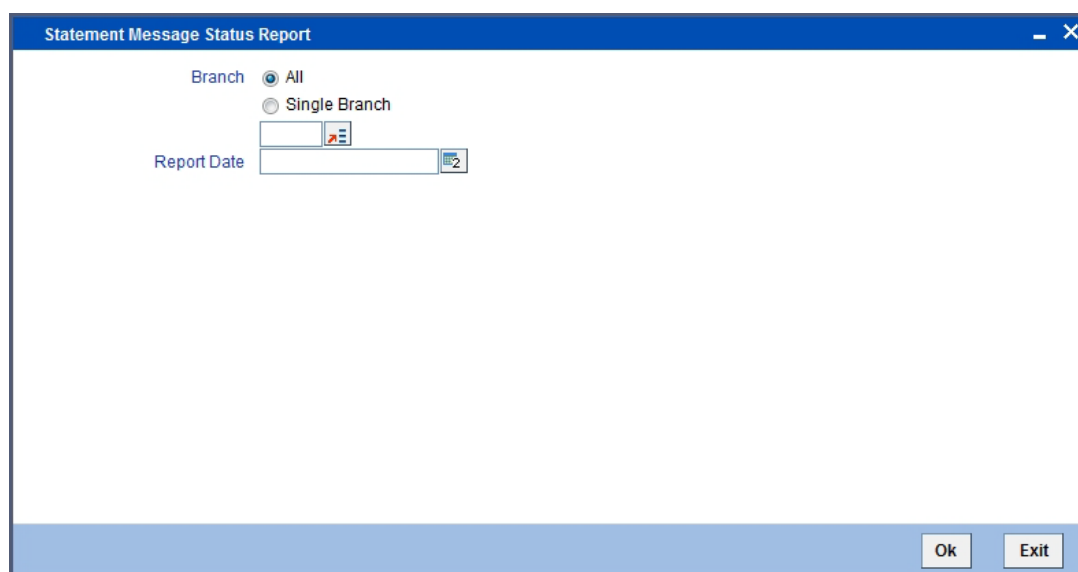

### Branch Code

You can generate this report for all the branches or a single branch alone. You can indicate the branch for which the report is being generated using the following options:

- All – If you choose this, the system will generate the report for all the branches.
- Single – If you choose this, you need to specify the branch code for which the report should be generated. The option list displays all valid branch codes maintained in the system. Choose the appropriate one.

### Date

Specify the date from the adjoining calendar list.

## 14.6.1 Contents of the Report

The parameters specified while generating the report are printed at the beginning of the report. The contents of Counterparty Confirmation Pending report have been discussed under the following heads:

### Header

The 'Header' carries the title of the report, branch code, branch date, user ID, module from which the report has been generated, date and time at which the report has been generated and the page number of the report.

### Body of the Report

You can find the following details in the body of the report:

Branch	Indicates the branch code
Branch Date	Indicates the branch date
Status	Indicates the status
Module	Indicates the module code
Document Reference	Indicates the document reference number
Reference Number	Indicates the reference number

Message Type	Indicates the type of message
Swift Message Type	Indicates the swift message type
Address	Indicates the address
Currency	Indicates the currency of the transaction
Amount	Indicates the amount

---

## 15. Function ID Glossary

### C

CSSJOBBER ..... 7-4

### I

IMAGE ..... 5-3

ISDCCYRS ..... 3-23

### M

MSDADVFT ..... 7-1

MSDCACAD ..... 6-1

MSDCOMMS ..... 11-7

MSDCUSAD ..... 6-8

MSDETPDE ..... 8-9

MSDFFT ..... 11-1

MSDFFTMP ..... 11-10

MSDMCS ..... 5-1

MSDMEDIA ..... 4-1

MSDMPREV ..... 3-10

MSDMSGTM ..... 3-9

MSDMSTYP ..... 3-7

MSDPREF ..... 3-1

MSDSTPSC ..... 10-13

MSRDSWFT ..... 14-4

MSRMSRPT ..... 14-1

MSRPLEXP ..... 14-2

MSRPLSUX ..... 14-3

MSRSTMSG ..... 14-5

MSSCUSAD ..... 6-17

MSSETPDE ..... 8-10

MSSINBRS ..... 10-2

MSSNOTIF ..... 10-12

MSSOUBRS ..... 8-2

MSSUNARC ..... 9-1

### O

OLE\_LINK3 ..... 5-1

### P

\_PICTUREBULLETS ..... 12-5