

Oracle[®] MICROS Hardware Site Preparation Guide



E81016-25
August 2024



Oracle MICROS Hardware Site Preparation Guide,

E81016-25

Copyright © 2012, 2024, Oracle and/or its affiliates.

This software and related documentation are provided under a license agreement containing restrictions on use and disclosure and are protected by intellectual property laws. Except as expressly permitted in your license agreement or allowed by law, you may not use, copy, reproduce, translate, broadcast, modify, license, transmit, distribute, exhibit, perform, publish, or display any part, in any form, or by any means. Reverse engineering, disassembly, or decompilation of this software, unless required by law for interoperability, is prohibited.

The information contained herein is subject to change without notice and is not warranted to be error-free. If you find any errors, please report them to us in writing.

If this is software, software documentation, data (as defined in the Federal Acquisition Regulation), or related documentation that is delivered to the U.S. Government or anyone licensing it on behalf of the U.S. Government, then the following notice is applicable:

U.S. GOVERNMENT END USERS: Oracle programs (including any operating system, integrated software, any programs embedded, installed, or activated on delivered hardware, and modifications of such programs) and Oracle computer documentation or other Oracle data delivered to or accessed by U.S. Government end users are "commercial computer software," "commercial computer software documentation," or "limited rights data" pursuant to the applicable Federal Acquisition Regulation and agency-specific supplemental regulations. As such, the use, reproduction, duplication, release, display, disclosure, modification, preparation of derivative works, and/or adaptation of i) Oracle programs (including any operating system, integrated software, any programs embedded, installed, or activated on delivered hardware, and modifications of such programs), ii) Oracle computer documentation and/or iii) other Oracle data, is subject to the rights and limitations specified in the license contained in the applicable contract. The terms governing the U.S. Government's use of Oracle cloud services are defined by the applicable contract for such services. No other rights are granted to the U.S. Government.

This software or hardware is developed for general use in a variety of information management applications. It is not developed or intended for use in any inherently dangerous applications, including applications that may create a risk of personal injury. If you use this software or hardware in dangerous applications, then you shall be responsible to take all appropriate fail-safe, backup, redundancy, and other measures to ensure its safe use. Oracle Corporation and its affiliates disclaim any liability for any damages caused by use of this software or hardware in dangerous applications.

Oracle®, Java, MySQL, and NetSuite are registered trademarks of Oracle and/or its affiliates. Other names may be trademarks of their respective owners.

Intel and Intel Inside are trademarks or registered trademarks of Intel Corporation. All SPARC trademarks are used under license and are trademarks or registered trademarks of SPARC International, Inc. AMD, Epyc, and the AMD logo are trademarks or registered trademarks of Advanced Micro Devices. UNIX is a registered trademark of The Open Group.

This software or hardware and documentation may provide access to or information about content, products, and services from third parties. Oracle Corporation and its affiliates are not responsible for and expressly disclaim all warranties of any kind with respect to third-party content, products, and services unless otherwise set forth in an applicable agreement between you and Oracle. Oracle Corporation and its affiliates will not be responsible for any loss, costs, or damages incurred due to your access to or use of third-party content, products, or services, except as set forth in an applicable agreement between you and Oracle.

Contents

Preface

1 Introduction to the Oracle MICROS Hardware

2 Oracle Workstation 8 Series

Workstation 8 Series Technical Specifications 2-1

3 MICROS Express Station 4 Series

MICROS Express Station 4 Series Basic Features 3-1

MICROS Express Station 4 Series Primary I/O Ports 3-2

MICROS Express Station 4 Series Technical Specifications 3-4

4 MICROS Workstation 625/655

MICROS Workstation 625/655 Basic Features 4-1

MICROS Workstation 625/655 Primary I/O Ports 4-2

MICROS Workstation 625/655 Technical Specifications 4-4

5 MICROS Compact Workstation 310

MICROS Compact Workstation 310 Technical Specifications 5-2

MICROS Compact Workstation 310 Features 5-3

MICROS Compact Workstation 310 Primary I/O Ports 5-4

MICROS Flexible Stand 5-4

MICROS Basic Stand 5-5

MICROS Compact Workstation 310 Accessories 5-7

6 The Oracle MICROS Tablet 700 Series

MICROS Tablet 700 Series Technical Specifications 6-1

MICROS Tablet 720 Features 6-3

	MICROS Tablet 721/721P Features	6-5
	Tablet Accessories	6-7
	Replacing the Bridge Battery in the MICROS Tablet 720	6-10
7	MICROS Workstation 610, 620, and 650	
	MICROS Workstation 610/620/650 Features and Specifications	7-1
	MICROS Workstation 610/620/650 Primary I/O Ports	7-3
	MICROS Workstation 610/620/650 Series Internal I/O Ports	7-4
	MICROS Workstation 6 Series Adjustable Stand	7-5
8	MICROS Tablet E-Series 8 and E-Series 11	
	MICROS Tablet E-Series with MSR Sleeve Features	8-2
	MICROS Tablet E-Series 8 with MSR Sleeve Connectors	8-3
9	MICROS Tablet R-Series	
	MICROS Tablet R-Series Features	9-1
	MICROS Tablet R-Series Connectors	9-3
10	MICROS Base Station	
	MICROS Base Station Features	10-2
	MICROS Base Station Connectors	10-3
11	MICROS Tablet Multi-Unit Charger	
	MICROS Tablet Multi-Unit Charger Features	11-1
12	MICROS PC Workstation 2015	
	MICROS PC Workstation 2015 Features	12-1
	MICROS PC Workstation 2015 Connectors	12-2
13	MICROS PC Workstation 2010	
	MICROS PC Workstation 2010 Features	13-1
	MICROS PC Workstation 2010 Connectors	13-2

14	MICROS Workstation 5A	
	MICROS Workstation 5A Features	14-1
	MICROS Workstation 5A Connectors	14-2
15	MICROS Workstation 5	
	MICROS Workstation 5 Features	15-1
	MICROS Workstation 5 Connectors	15-2
16	MICROS Workstation 4 LX	
	MICROS Workstation 4 LX Features	16-1
	MICROS Workstation 4 LX Connectors	16-2
17	MICROS Keyboard Workstation 270	
	MICROS Keyboard Workstation 270 Features	17-1
	MICROS Keyboard Workstation 270 Connectors	17-2
18	Order Confirmation System	
	Order Confirmation Controller (OCC) Features	18-1
	Remote Display Unit Features and Requirements	18-2
	Order Confirmation System Installation	18-2
	Order Confirmation Controller (OCC) Requirements	18-2
	Remote Display Pedestal Requirements	18-3
19	e7 BOC or Digital Menu and Marketing System Controller	
	e7 BOC Features and Requirements	19-1
20	Printing Devices	
	Ethernet	20-1
	RS232	20-1
	MICROS Integrated Device Network (IDN)	20-1
21	Peripheral Devices	
	10-Inch Customer Display	21-1
	Customer Display	21-1
	Cash Drawer	21-2

Barcode Reader	21-2
Coin Changer	21-2
Magnetic Card Reader	21-2
Scale	21-2
Order Confirmation and Payment Terminal	21-2

22 Kitchen Display System (KDS)

Kitchen Display System Installation	22-2
KDS Mounting	22-2
KDS Controllers	22-2
MICROS Wired Bumpbar Installation Considerations	22-2
MICROS Wireless Bumpbar Installation Considerations	22-2

23 e7 Kitchen Video Monitor Controller

e7 KVM Controller Features and Requirements	23-2
e7 Kitchen Video Monitor (KVM) Installation	23-3

24 Environmental Requirements and Equipment Placement Considerations

Location	24-1
Foreign Materials	24-1
Noise Induction	24-1
Electrostatic Discharge	24-1
Humidity	24-2
Custom Cabinets and Enclosures	24-2
Temperature	24-2
Lithium Ion Battery Pack Storage Considerations	24-3

25 AC Power Requirements

Preferred AC Power System	25-1
AC Power System Grounding	25-3
MICROS Power Panel Grounding	25-3
MICROS Branch Circuit Grounding	25-3
AC Power Receptacles Grounding	25-3
Additional Methods for AC Power	25-4
Relaxed/Power Conditioned AC Power System	25-4
Power Conditioned AC Power System	25-5
AC Power Consumption and Volt-Amp Ratings for MICROS Equipment	25-5

26	Recommended AC Power Conditioning and UPS Equipment	
	UPS Product Requirements	26-1
	PowerVar Single Phase UPS Desktop Models	26-1
	ONEAC Rack Mount UPS	26-2
	Standard Power Conditioners	26-2
	POWERVAR Ground Guard Line Conditioners	26-3
	Ethernet Line Protectors	26-4
	PowerVar Single Phase Desktop UPS - Estimated Run Times	26-4
27	Cable Requirements	
28	Wireless Infrastructure	
29	Network Requirements and Planning	
	Structured Cabling Systems	29-1
	Elements of a Structured Cabling System	29-3
	Structured Cabling Examples	29-4
	Cable Types	29-7
	Cable Categories	29-7
	Mechanical and Electrical Considerations for Cable Installation	29-8
30	Ethernet Network Installation	
	Topology	30-1
	Cable Runs	30-1
	Workstations, IP Printers, KDS Controller, and OCC	30-1
	LAN Cable Termination	30-1
	Extending Ethernet Beyond the 90 Meter Limit with Fiber Optic Cable	30-3
31	Integrated Device Network (IDN) Installation	
	Recommended Cables for a MICROS RS422 ION Network	31-1
	Traditional MICROS RS422 Cabling and Connection Hardware	31-2
	Wall Plate	31-2
	6-Pin Modular Connector	31-2
	Patch Cables	31-2
	IDN Connectors on MICROS Workstations	31-2

Cable Runs	31-3
Shielded Cable and Connection Hardware for IDN	31-3
Components	31-3
IDN Connectors	31-3
Terminating the IDN Cable	31-4

32 Equipment Dimensions

MICROS Express Station 4 Series Dimensions	32-1
MICROS Workstation 625/655 with Adjustable Stand - Dimensions	32-2
MICROS Compact Workstation 310 with Flexible Stand - Dimensions	32-3
MICROS Compact Workstation 310 with Basic Stand - Dimensions	32-3
MICROS Tablet 721P - Front and Side Dimensions	32-4
MICROS Tablet 721 - Front and Side Dimensions	32-5
MICROS Tablet 720 - Front and Side Dimensions	32-5
MICROS Tablet 700 Series - 4-Bay Tablet Charger Dimensions	32-7
MICROS Tablet 700 Series - 4-Bay Battery Charger Dimensions	32-8
MICROS Workstation 6 Series - Front and Back Dimensions with Adjustable Stand	32-9
MICROS Workstation 6 Series - Side Dimensions with Adjustable Stand	32-10
MICROS Workstation 6 Series - Side Dimensions with Adjustable Stand and High-Mount Customer Display	32-11
MICROS Workstation 6 Series - Side Dimensions with 10-Inch Customer Display and High Mount	32-12
MICROS Workstation 6 Series - 10-Inch Customer Display with Pole Mount Dimensions	32-13
MICROS Workstation 6 Series - Wall Mount Dimensions	32-14
MICROS Tablet E-Series 8 Dimension	32-16
MICROS Tablet E-Series 11 Dimensions	32-16
MICROS Tablet E-Series Multi-Unit Charger - Surface Mount Dimensions	32-17
MICROS Tablet E-Series Multi-Unit Charger - Wall Mount Dimensions	32-18
MICROS Tablet R-Series Dimensions	32-19
MICROS Tablet R-Series - Base Station Dimensions with Peripherals	32-20
MICROS PC Workstation 2015 - Low Profile Dimensions	32-21
MICROS PC Workstation 2015 - Low Profile with Customer Facing Display Dimensions	32-22
MICROS PC Workstation 2015 Adjustable Stand Dimensions	32-23
MICROS PC Workstation 2015 on Stand - LCD Customer Display Dimensions	32-23
MICROS PC Workstation 2015 - Adjustable Stand Protégé Customer Display Dimensions	32-24
MICROS Workstation 5/5A - Low Profile Dimensions	32-25
MICROS Workstation 5/5A Dimensions with Integrated LCD Customer Display	32-26
MICROS Workstation 5/5A Dimensions on Adjustable Stand	32-27
MICROS Workstation 5/5A Dimensions on Stand with LCD Customer Display	32-28
MICROS Workstation 5/5A Dimensions on Stand with Protégé Customer Display	32-29
MICROS Workstation 5/5A Dimensions on Stand /w Vivo Payment Terminal	32-30
MICROS Workstation 4/4 LX - Low Profile (LP) Dimensions	32-31

MICROS Workstation 4/4 LX – Low Profile with Rear Customer Display Dimensions	32-32
MICROS Workstation 4/4 LX Dimensions on Adjustable Stand	32-33
MICROS Workstation 4/4 LX Dimensions on Stand with LCD Customer Display	32-34
MICROS Workstation 4/4 LX Dimensions on Stand with VFD Customer Display	32-35
MICROS Workstation 4/4 LX Dimensions on Wall Mount Bracket	32-36
MICROS KW270 Low Profile Dimensions	32-37
MICROS KW270 on Stand with Updated Scanner Housing Dimensions	32-38
Order Confirmation Controller and Wall Bracket Dimensions	32-39
Order Confirmation System Remote Display Pedestal - Basic Dimensions	32-40
Order Confirmation System Remote Display Pedestal - Detail 1 Dimensions	32-41
Order Confirmation System Remote Display Pedestal - Detail 2 Dimensions	32-42
Order Confirmation System Remote Display Pedestal Baseplate Dimensions	32-43
MICROS 10-Key Bumpbar Mounting Bracket Dimensions	32-44
MICROS 20-Key Bumpbar Mounting Bracket Dimensions	32-44
TM-T88 Thermal Roll Printer Dimensions	32-45
U200D Roll Printer Dimensions	32-45
U220 Auto-Cut Roll Printer Dimensions	32-46
U200B Auto-Cut Roll Printer Dimensions	32-46
U230 Auto-Cut Roll Printer Dimensions	32-47
Pole Mount (6 inch) Protégé Customer Display Dimensions	32-48
Series 1 Pole Customer Display Dimensions	32-49
Series 2 Pole Customer Display Dimensions	32-50
Cash Drawer Dimensions	32-51

33 Connectors

RS422-A, RS422-B or IDN	33-1
Modular RS232 COM or Powered RJ45 Port Diagram	33-3
RS232 DB9 Connector	33-3
Cash Drawer 1 and 2 Connectors	33-4
Pole Customer Display Connector	33-5

34 Hook-Up Cables

Null Modem Cable for e7 KVM Controller	34-1
IDN Port Conversion Cables	34-1
8-Pin to 6-Pin Hook-up RS422 Cable	34-3
IDN to EIA/TIA-568-A Patch Cable	34-4

35 FCC/DOC Statement

Federal Communications Commission Radio Frequency Interference Statement	35-1
Canadian Department of Communications Statement	35-1

Preface

This manual describes preparing the site prior to installing the Oracle MICROS Point of Sale equipment. This ranges from installing the required AC power and grounding system to installing and terminating various data communications cables. After the AC Power system and data communication cables are installed, thoroughly inspect the site to ensure the work is accurate.

Audience

This manual concentrates on the site preparation requirements of the Oracle MICROS Point of Sale (POS) hardware and is not related to a particular application. It is intended for installers and those personnel who prepare a site for the installation of the Oracle MICROS hardware.

The information in Chapters 3 and 4 is provided for personnel who fully understand the procedures and standards for installing AC power and grounding systems, as well as installing, terminating, and certifying Ethernet cables.

Customer Support

To contact Oracle Customer Support, access My Oracle Support at the following URL:

<https://support.oracle.com>

When contacting Customer Support, please provide the following:

- Product version and program/module name
- Functional and technical description of the problem (include business impact)
- Detailed step-by-step instructions to re-create
- Exact error message received
- Screen shots of each step you take

Documentation

Oracle Hospitality product documentation is available on the Oracle Help Center at <http://docs.oracle.com/en/industries/hospitality/>.

Revision History

Table 1 Revision History

Date	Description of Change
June 2015	<ul style="list-style-type: none">• Re-branded MICROS Hardware Site Prep Guide to Oracle.
July 2015	<ul style="list-style-type: none">• Updated copyright information.

Table 1 (Cont.) Revision History

Date	Description of Change
September 2015	<ul style="list-style-type: none"> • Added the Workstation 6 and Tablet E-Series. • Updated the Tablet R-Series information. • Updated the images for the Workstations and Tablets. • Removed the AC Power Agreement and updated the AC Power Requirements. • Updated references to MICROS part numbers.
October 2015	<ul style="list-style-type: none"> • Updated the Cash Drawer equipment dimensions. • Updated the cable recommendations.
November 2015	<ul style="list-style-type: none"> • Added references to the MICROS Tablet E-Series Setup Guide.
December 2015	<ul style="list-style-type: none"> • Added the reclined height of Workstation 6 to the equipment dimensions.
April 2016	<ul style="list-style-type: none"> • Added information for the Workstation 6 Series.
November 2016	<ul style="list-style-type: none"> • Added information for the Workstation 610 configuration with Microsoft Windows 8.1 and a 64 GB SSD. • Published in HTML and PDF format.
March 2017	<ul style="list-style-type: none"> • Added information for the Workstation 620 and Workstation 650 configurations without MSR.
April 2017	<ul style="list-style-type: none"> • Added information for the Tablet 720.
December 2017	<ul style="list-style-type: none"> • Added information for the Tablet 721.
February 2018	<ul style="list-style-type: none"> • Added information for the Compact Workstation 310.
October 2018	<ul style="list-style-type: none"> • Miscellaneous fixes and updates.
April 2019	<ul style="list-style-type: none"> • Miscellaneous improvements.
March 2020	<ul style="list-style-type: none"> • Added information for the Workstation 625/655.
April 2020	<ul style="list-style-type: none"> • Updated Workstation 625/655 images.
September 2020	<ul style="list-style-type: none"> • Added Tablet 721P. • Added Express Station 4 Series.
October 2021	<ul style="list-style-type: none"> • Updated Workstation 6 Series 2 (625/655) technical specifications.
January 2022	<ul style="list-style-type: none"> • Updated Tablet 721P accessories part numbers.
April 2022	<ul style="list-style-type: none"> • Updated Tablet 721P accessories table.
August 2024	<ul style="list-style-type: none"> • Updated <i>AC Power Consumption and Volt-Amp Ratings for MICROS Equipment</i> table.

1

Introduction to the Oracle MICROS Hardware

This guide introduces the Oracle MICROS Point-of-Sale (POS) hardware plus the printers and network connections required to tie it all together.

From a site preparation standpoint, a typical system may be composed of the following components:

- MICROS Workstations
- Peripherals such as Scales, Coin Changers, and Bar Code Readers
- Printing Devices using RS232, IDN, and Ethernet interfaces
- Kitchen Display Systems (KDS)
- e7 Kitchen Video Monitor (KVM) Controller
- Order Confirmation System (OCS)
- e7 Back Office Controller or Digital Menu Board Controller

The [AC Power Requirements](#) and [Cable Requirements](#) sections provide more information on the AC power, cable, and network requirements for the MICROS hardware.

2

Oracle Workstation 8 Series

Overview

The Workstation 820 features a clean, modern design that complements any commercial space and provides the performance, flexibility, and reliability your business needs to succeed. Customize your Workstation 820 with accessories designed to integrate seamlessly with minimal setup time, or choose a preassembled Workstation 8 configuration to get up and running ASAP.

Available accessories:

- **Vertical Stand:** A modern, stable stand for the Workstation 820.
- **Low Profile Stand:** Rock-solid support with a reduced vertical footprint for the Workstation 820.
- **Peripheral Expansion Module:** Expanded connectivity options for current and future needs.
- **Customer Facing Display for Vertical Stand:** Mounts on the Vertical Stand.
- **Customer Facing Display for Low Profile Stand:** Mounts on the Low Profile Stand.
- **Freestanding Customer Facing Display:** 7-Inch Customer Facing Display with integrated kickstand that allows rapid countertop deployment.
- **Customer Facing Display with Pole Mount:** 7-Inch Customer Facing Display pre-mounted on a pole. Pole base supports cash drawer mounting.

Workstation 8 Series Technical Specifications

Table 2-1 Technical Specifications for the MICROS Workstation 820

Feature	Description
Processor*	Intel Celeron J6413 Quad-Core
Graphics*	Intel UHD Graphics
Display	14-inch FHD (1920x1080p) on-cell touchscreen with 250nit brightness and anti-glare coating
Memory*	8GB
Storage*	<ul style="list-style-type: none">• 256GB SSD (Workstation 820 with Microsoft Windows)• 128GB SSD (Workstation 820 with Oracle Linux for MICROS)
Operating System	<ul style="list-style-type: none">• Microsoft Windows 10 IoT Enterprise LTSC 2021 64 bit• Oracle Linux for MICROS 64 bit
RFID (optional)	Integrated RFID reader for employee sign in. Reads 125 kHz and 13.56 MHz RFID tags.
Audio	Basic audio confirmations. HD Audio, single speaker.

Table 2-1 (Cont.) Technical Specifications for the MICROS Workstation 820

Feature	Description
Network	<ul style="list-style-type: none"> 1 - Network port. (Requires Ethernet adapter cable for Oracle MICROS Workstation 8 Series for direct connection to Ethernet port) Wi-Fi (optional): Intel Wi-Fi 6E AX210 (Gig+) 802.11ax Tri Band 2x2 160MHz channels, BT5.3
USB	<ul style="list-style-type: none"> 1 - USB power input 1 - Custom low-profile GbE port 1 - USB CFD (Customer Facing Display) port with DisplayPort support <p>The Peripheral Expansion Module (optional) includes the following ports:</p> <ul style="list-style-type: none"> 1 - Ethernet 5 - USB 1 - IDN 1 - Serial 2 - Cash drawer
Power Supply	Compatible with the Workstation 8 Series power supply.
Supported Stands	Vertical Stand, Low Profile Stand
Weight	1.09 kg / 2.4 lbs
Dimensions	<ul style="list-style-type: none"> Workstation only: 329.11mm x 215.79mm x 17mm (12.95 x 8.49 x 0.67 inches) Workstation with Vertical Stand: 329.11mm x 289mm x 182mm (12.95 x 11.38 x 7.17 inches) Workstation with Low Profile Stand: 329.11mm x 100mm x 296mm (12.95 x 3.94 x 11.65 inches) Workstation with Low Profile Stand and Customer Facing Display: 329.11mm x 100mm x 314mm (12.95 x 3.94 x 12.36 inches) <p>All measurements are approximate.</p>
Operating Temperature and Humidity	0 °C (32 °F) to 50 °C (122 °F); 90% Max relative humidity (non-condensing)
Enclosure	<ul style="list-style-type: none"> IP Rating: Workstation 8 System Unit: IP54. When used with the optional Peripheral Expansion Module: IP34. All-aluminum casework provides passive system cooling (no fans)
Certifications	FCC Class A, UL, CE, TUV, RoHS, China RoHS

*The Workstation 820 enclosure is non-serviceable. Internal components cannot be upgraded.

3

MICROS Express Station 4 Series

The Oracle MICROS Express Station 4 Series is the heart of the Oracle MICROS Kitchen Display System. With options such as Wi-Fi, RFID, fingerprint reader, magnetic stripe reader, audio expansion bar, and touch-capable screens, the Express Station 4 Series brings leading-edge technology, 24/7 reliability, and top-tier performance to back of house operations and point of sale environments.



MICROS Express Station 4 Series Basic Features

The Oracle MICROS Express Station 4 Series includes the following basic features.

Figure 3-1 Oracle MICROS Express Station 4 Series Basic Features

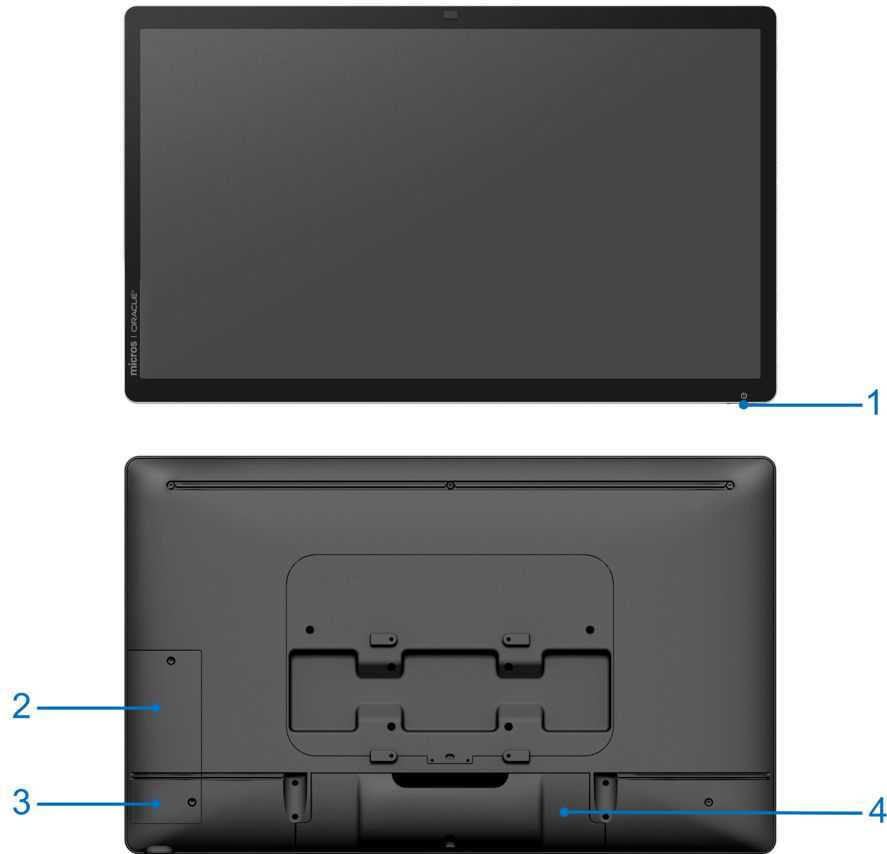

Table 3-1 Oracle MICROS Express Station 4 Series Basic Features

Feature
1. Power Button
2. Magnetic Stripe Reader (optional)
3. Fingerprint Reader (optional)
4. Input/Output Panel (located behind I/O Panel Cover). See Primary I/O Ports for more information.

MICROS Express Station 4 Series Primary I/O Ports

Figure 3-2 Primary I/O Panels of the MICROS Express Station 4 Series

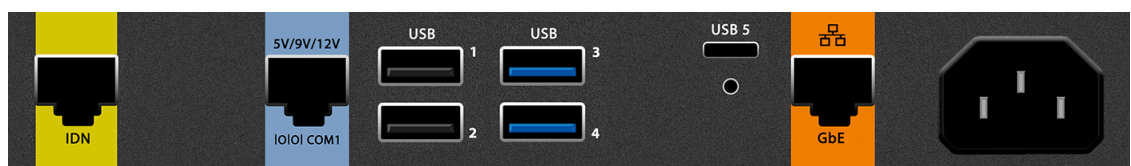

Table 3-2 Oracle MICROS Express Station 4 Series I/O Ports





Port	Description
 <p>The image shows a yellow rectangular connector with a black port in the center. The text "IDN" is printed in black on the yellow background below the port.</p>	IDN port (RS422/RS232)
 <p>The image shows a blue rectangular connector with a black port in the center. Above the port, the text "5V/9V/12V" is printed. Below the port, the text "IOIOI COM1" is printed.</p>	COM1 port
 <p>The image shows two standard black USB Type-A ports stacked vertically. The word "USB" is printed above the top port. The numbers "1" and "2" are printed to the right of the top and bottom ports, respectively.</p>	USB ports
 <p>The image shows two high-speed USB Type-A ports stacked vertically. The word "USB" is printed above the top port. The numbers "3" and "4" are printed to the right of the top and bottom ports, respectively. The ports have a blue horizontal stripe across the opening.</p>	High speed USB ports
 <p>The image shows a high-speed USB Type-A port (with a blue stripe) and a circular audio jack below it. The text "USB 5" is printed above the port.</p>	High speed USB port

Table 3-2 (Cont.) Oracle MICROS Express Station 4 Series I/O Ports

Port	Description
	Gigabit Ethernet port
	Power port

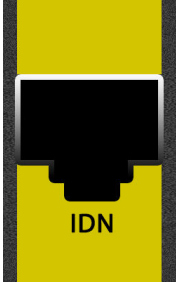
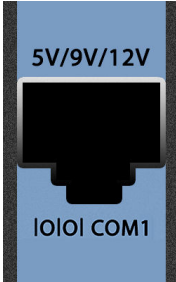
MICROS Express Station 4 Series Technical Specifications

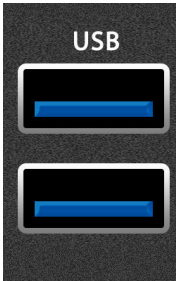
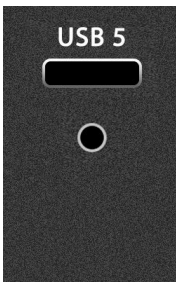
Table 3-3 Technical Specifications for the Oracle MICROS Express Station 4 Series

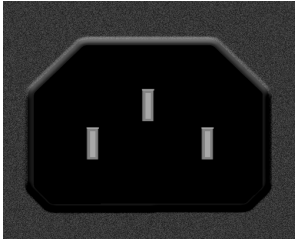
Feature	Description
Processor	Intel Atom x5 Dual Core Processor (Express Station 400) / Intel Atom x5 Quad Core Processor (Express Station 410)
Display	<ul style="list-style-type: none"> 23.8 inch widescreen high definition LCD. Touch and non-touch capable screens available.
Memory	4 GB (Express Station 400) / 8 GB (Express Station 410)
Storage	<ul style="list-style-type: none"> 64 GB SATA 3.0 SSD (Express Station 400) / 128 GB SATA 3.0 SSD (Express Station 410)
Operating System	<ul style="list-style-type: none"> Microsoft Windows 10 IoT Enterprise LTSC 64 bit Oracle Linux for MICROS 64 bit
Magnetic Stripe Reader (Optional)	Modular integrated 3-track magnetic card reader; capable of hardware encryption at the swipe. Merchantlink encryption key pre-injected.
Modular Integrated Biometric Fingerprint Reader (Optional)	Provides rapid identification and secure verification capabilities for recognition of individual users without requiring passwords or card swipes.
Audio	<ul style="list-style-type: none"> Optional Audio Expansion Bar for OS audio.
Network	<ul style="list-style-type: none"> 1 - GbE RJ45 Ethernet port 2x2 802.11 a/b/g/n/ac Wi-Fi, with Dual Band radio, Downlink MU-MIMO, and Bluetooth 5 (Express Station 410 only)
USB	5 Total: <ul style="list-style-type: none"> 2 - USB 3- High Speed USB

Table 3-3 (Cont.) Technical Specifications for the Oracle MICROS Express Station 4 Series

Feature	Description
Serial Ports	2 Total Standard: <ul style="list-style-type: none"> • 1 - RJ45 RS232 powered (0/5/9/12V 1A selectable) • 1 - RJ45 RS422/RS232 IDN
Internal Power Supply	Universal Input 85-264VAC, 50-60 HZ / C13 connector
Supported Stands	Compact Workstation 3 Series Flexible Stand, Oracle MICROS Compact Stand, Kiosk 110
Weight	12.9 lbs
Dimensions	Approximately 561mm x 340mm x 61mm (22 x 13.4 x 2.4 inches)
Operating Temperature and Humidity	0 °C (32 °F) to 60 °C (140 °F); 90% Max relative humidity (non-condensing)
Enclosure	<ul style="list-style-type: none"> • Combination of cast aluminum, rugged PC-ABS plastic blend, and PC +10% glass fiber • Spill-resistant enclosure (IP44 without port plugs, IP54 with port plugs installed) • Passive cooling (no fans) • Casework open detection (configurable via BIOS) • VESA 100 mount compatible
Certifications	FCC Class A, UL, CE, TUV, RoHS, China RoHS

4

MICROS Workstation 625/655

The Workstation 625 and the Workstation 655 join the Oracle MICROS Workstation 6 Series lineup to provide leading-edge point of sale technology with 24/7 reliability and top-tier performance.

What's New

- Oracle Linux for MICROS operating system (optional) for enhanced stability, security, and performance.
- Larger viewable display area within a smaller physical footprint.
- Audio expansion bar (optional) for OS audio.
- 2 Gigabit Ethernet ports. 2nd port can be used as dual-NIC for workstation or as a hub for network-connected peripherals.
- 802.11 a/b/g/n/ac Wi-Fi with 2x2 MIMO and Bluetooth 5.
- RFID login capability.



MICROS Workstation 625/655 Basic Features

The Oracle MICROS Workstation 625/655 includes the following basic features.

 **Note:**

Oracle MICROS offers the Workstation 625/655 in multiple hardware configurations. Depending on the model, your workstation may not include some of the features described in this document.

Figure 4-1 Oracle MICROS Workstation 625/655 Basic Features

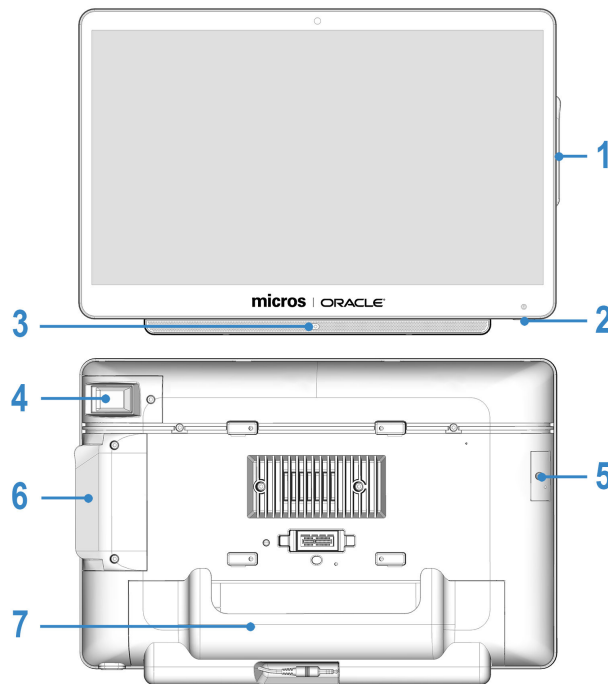

Table 4-1 Oracle MICROS Workstation 625/655 Basic Features

Feature
1. Magnetic Stripe Reader
2. Power Button
3. Audio expansion bar (optional)
4. Fingerprint Reader (optional)
5. Storage Expansion (optional)
6. Magnetic Stripe Reader (rear view)
7. Input/Output Panel (located behind I/O Panel Cover). See Primary I/O Ports for more information.

MICROS Workstation 625/655 Primary I/O Ports

The Oracle MICROS Workstation 625 and Workstation 655 include an array of ports for a variety of connectivity options. Note that port availability varies by model.

Figure 4-2 Primary I/O Panel of the MICROS Workstation 625X/655X and 625E

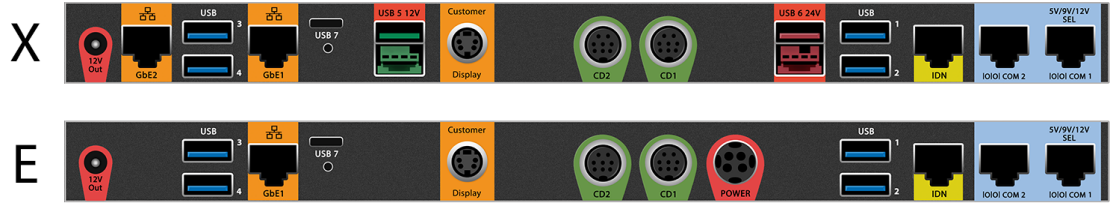

Table 4-2 Oracle MICROS Workstation 625/655 I/O Ports





Port	Description
	12V out port
	Gigabit Ethernet port (2x). The 2nd RJ45 Port can be used as dual-NIC for workstation or as a hub for network-connected peripherals.
	High speed USB ports (4x)
	Ultra high speed USB port (DisplayPort capable)
	12V powered USB port
	Customer display port. The customer display port supports existing pole displays and the Workstation 6 integrated customer display.
	Cash drawer port (12/24V selectable - 2x) Series 2 cash drawer ports are compact and feature an expanded number of pins to accommodate more options on the cash drawer interface. You can use an adapter cable for backwards compatibility to existing cash drawers.
	4-pin power Mini DIN

Table 4-2 (Cont.) Oracle MICROS Workstation 625/655 I/O Ports

Port	Description
	24V powered USB port
	IDN port (RS422/RS232)
	RJ-45 serial ports (2x) <ul style="list-style-type: none"> • COM 1: RS232 powered 5V/9V/12V 1A (selectable) • COM 2: RS232 unpowered

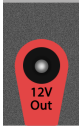
MICROS Workstation 625/655 Technical Specifications

The following table contains the technical specifications for the Workstation 655X. Other models may not include identical components and capabilities. Contact your Oracle MICROS representative for more information.

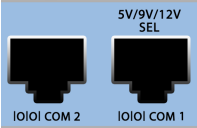
Table 4-3 Technical Specifications for the MICROS Workstation 655X

Feature	Description
Processor	Intel Core i5-8265U Quad Core 1.6GHz
Display	<ul style="list-style-type: none"> • 15.6 inch widescreen high definition display (1920x1080p) with 500nit brightness and anti-glare coating • Optically bonded screen for increased contrast in bright lighting conditions • Multi-touch projected capacitive touchscreen with edge-to-edge active area
Memory	2 - SODIMM Sockets; 8GB DDR4L 2400MHz
Storage	<ul style="list-style-type: none"> • 256 GB M.2 NVMe SATA 3.0 SSD standard
Removable Recovery Media	128/256 GB SSD. Allows rapid restore to the original factory condition.
Operating System	<ul style="list-style-type: none"> • Microsoft Windows 10 IoT Enterprise LTSC 64 bit • Oracle Linux for MICROS 64 bit
Magnetic Stripe Reader (Optional)	Modular integrated 3-track magnetic card reader; capable of hardware encryption at the swipe. Merchantlink encryption key pre-injected.
Modular Integrated Biometric Fingerprint Reader (Optional)	Provides rapid identification and secure verification capabilities for recognition of individual users without requiring passwords or card swipes.
RFID	Integrated RFID reader for employee sign in. Reads 125 kHz and 13.56 MHz RFID tags.
Audio	<ul style="list-style-type: none"> • Optional Audio Expansion Bar for OS audio.

Table 4-3 (Cont.) Technical Specifications for the MICROS Workstation 655X

Feature	Description
Network	<ul style="list-style-type: none"> • 2 - GbE RJ45 Ethernet ports (2nd RJ45 port can be used as dual-NIC for workstation or as a hub for network-connected peripherals.) • 802.11 a/b/g/n/ac, 2x2 MIMO with dual band radio and Bluetooth 5.0. Supports VPro on Intel i5.
USB	9 Total: <ul style="list-style-type: none"> • 4 - High Speed USB on I/O panel • 1 - Ultra High Speed USB on I/O panel, DisplayPort capable • 1 - USB 12V powered header on I/O panel • 1 - USB 24V powered header on I/O panel • 2 - Internal Micro USB 2.0 ports
Serial Ports	3 Total Standard: <ul style="list-style-type: none"> • 1 - RJ45 RS232 powered (0/5/9/12V 1A selectable) • 1 - RJ45 RS232 • 1 - RJ45 RS422/RS232 IDN
Adjustable Stand Expansion Modules (Optional)	Powered USB Expansion Module: <ul style="list-style-type: none"> • 1 - 24V powered USB • 3 - 12V powered USB • 2 - High Speed USB ports
Cash Drawer Ports	2 - MICROS Series 2 cash drawer ports (12/24V selectable)
Customer Display Port	1 - MICROS DIN customer display port
Power Output	1 - 12V power out (2.5A)
Expansion Ports	<ul style="list-style-type: none"> • 1 - MICROS expansion port • 1 - Mini PCI Express port
Power Supply	<ul style="list-style-type: none"> • Compatible with Workstation 6 Series External Power Supply. • Universal input auto-switching power supply in Adjustable Stand. • External universal input auto-switching power supply for wall or VESA mount. • Select workstation models can be battery-powered via optional external enclosure.
Supported Stands	Workstation 6 Series Adjustable Stand, Workstation 6 Series wall mount, Compact Workstation 3 Series Flexible Stand, Compact Workstation 3 Series Basic Stand
Weight	Head unit: 5.4 lbs Adjustable Stand: 5 lbs
Dimensions	Workstation only: Approximately 366mm x 238mm x 42mm (14.4 x 9.37 x 1.65 inches) See Equipment Dimensions for more details.
Operating Temperature and Humidity	0 °C (32 °F) to 50 °C (122 °F); 90% Max relative humidity (non-condensing)
Enclosure	<ul style="list-style-type: none"> • Combination of cast aluminum, rugged PC-ABS plastic blend, and PC +10% glass fiber • Spill-resistant enclosure (IP43) • Passive cooling (no fans) • Casework open detection and workstation detached from stand detection (configurable via BIOS) • VESA 100 mount compatible

Table 4-3 (Cont.) Technical Specifications for the MICROS Workstation 655X

Feature	Description
Certifications	FCC Class A, UL, CE, TUV, RoHS, China RoHS

5

MICROS Compact Workstation 310

The Oracle MICROS Compact Workstation 310 consists of two configurations: the 310 and the 310R.

- The Oracle MICROS Compact Workstation 310 features an Intel Atom processor and runs the Microsoft Windows 10 IoT Enterprise operating system.
- The Oracle MICROS Compact Workstation 310R features an Intel Atom processor and runs the Microsoft Windows 10 IoT Enterprise operating system. The 310R includes a high-brightness LCD and is IP55 rated when using the supplied port plugs.

Each workstation is a Point of Sale (POS) terminal featuring a 10.1 inch widescreen 1280x800 display with a projected capacitive touch screen.

Figure 5-1 MICROS Compact Workstation 310



MICROS Compact Workstation 310 Technical Specifications

The following table contains the technical specifications for the Compact Workstation 310.

Table 5-1 Technical Specifications for the Oracle MICROS Compact Workstation 310

Feature	310	310R
Processor	Intel Atom x5-E3930 Processor @ 1.30GHz, 2C/2T, 2M Cache, (Apollo Lake)	
Display	10.1 inches, 16:10 WXGA, 1280(H) x800(V), 262k colors (RGB 6-bits), brightness= 300 Nits	10.1 inches, 16:10 WXGA, 1280(H) x800(V), 262k colors (RGB 6-bits) brightness= 800 Nits
Customer Display	256 x 64 Graphical OLED Display	
Touchscreen	Projected capacitive touchscreen with 10-point simultaneous touch	
Memory	4GB DDR3L @ 1600 MHz standard (8GB MAX)	
Storage	64GB eMMC v5.0, 400MB/sec MAX. Non-removable.	
Operating System	Microsoft Windows 10 IoT Enterprise (64-bit only)	
Magnetic Card Reader	3 track, encryption-capable with Merchantlink encryption key pre-injected	
Network	10/100/1G Ethernet, optional WiFi w/ Bluetooth	
USB	5 Total: <ul style="list-style-type: none"> • 2 USB 2.0 on I/O Panel (+5V @ 0.5A / 2.5W) • 2 USB on I/O Panel (+5V @ 09A / 4.5W) • 1 USB on I/O Panel (+5V/+15V @ 3.0A) 	
Serial Ports	2 Total: <ul style="list-style-type: none"> • 1 - RJ45 RS422/RS232 IDN • 1 - RJ45 RS232 	
Cash Drawer Ports	2 Total. For use with Series 2 Cash Drawers. Dongle available to convert Series 1 Cash Drawers to Series 2.	
Power Supply	External brick, 15V@5.33A (80W), 80~264VAC input. Optional battery power pack available.	
Weight	Workstation only: 3.64 lbs. Workstation with Flexible stand = 9.0 lbs.	
Dimensions	7.5 x 11.6 x 1.9 in / 191 x 294 x 47mm	
Operating Temperature	0-50C (32-122F)	-10-60C (14-140F)
Resistance to Spills and Debris	IP43 for Compact Workstation 310, IEC/EN 60529-22	IP55 for Compact Workstation 310R when using the supplied port plugs, IEC/EN 60529-22
Impact Resistance	EN62262-İK07: Impact energy= 2.0 joules	

MICROS Compact Workstation 310 Features

Figure 5-2 MICROS Compact Workstation 310 Features



Table 5-2 Compact Workstation 310 Features

Feature
1. Ambient Light Sensor
2. Magnetic Card Reader
3. Power Button
4. Customer Display
5. Fingerprint Reader (optional)
6. I/O Connector Panel (located under cover)

Powering On and Off

To power on, push and quickly release the power button. The display powers on after a few seconds. To power off for extended storage, use the Shut Down function provided in the operating system software.

MICROS Compact Workstation 310 Primary I/O Ports

Figure 5-3 Primary I/O Panel of the Oracle MICROS Compact Workstation 310



Table 5-3 Oracle MICROS Compact Workstation 310 Primary I/O Panel Ports

Port	Description
IDN	1x IDN (RS422/RS232) – RJ45
CD1/CD2	2x 8-pin miniDIN (12V) Series 2 Cash Drawer connectors
IOIOI COM1	1x RS232 – RJ45
USB 1/2	2x USB 2.0
USB 3/4	2x USB
Power	Accepts external power adapter with 15V@5.33A (80W), 80~264VAC and external battery power pack
USB 5	1x USB (15V @ 3A MAX, switchable to 5V via BIOS option)
Ethernet Port	GbE (10/100/1G)

MICROS Flexible Stand

The Flexible Stand (optional) provides a solid base for mounting the Compact Workstation 310, a wide range of positioning for optimal viewing angle, and enhanced cable management.

Figure 5-4 MICROS Flexible Stand

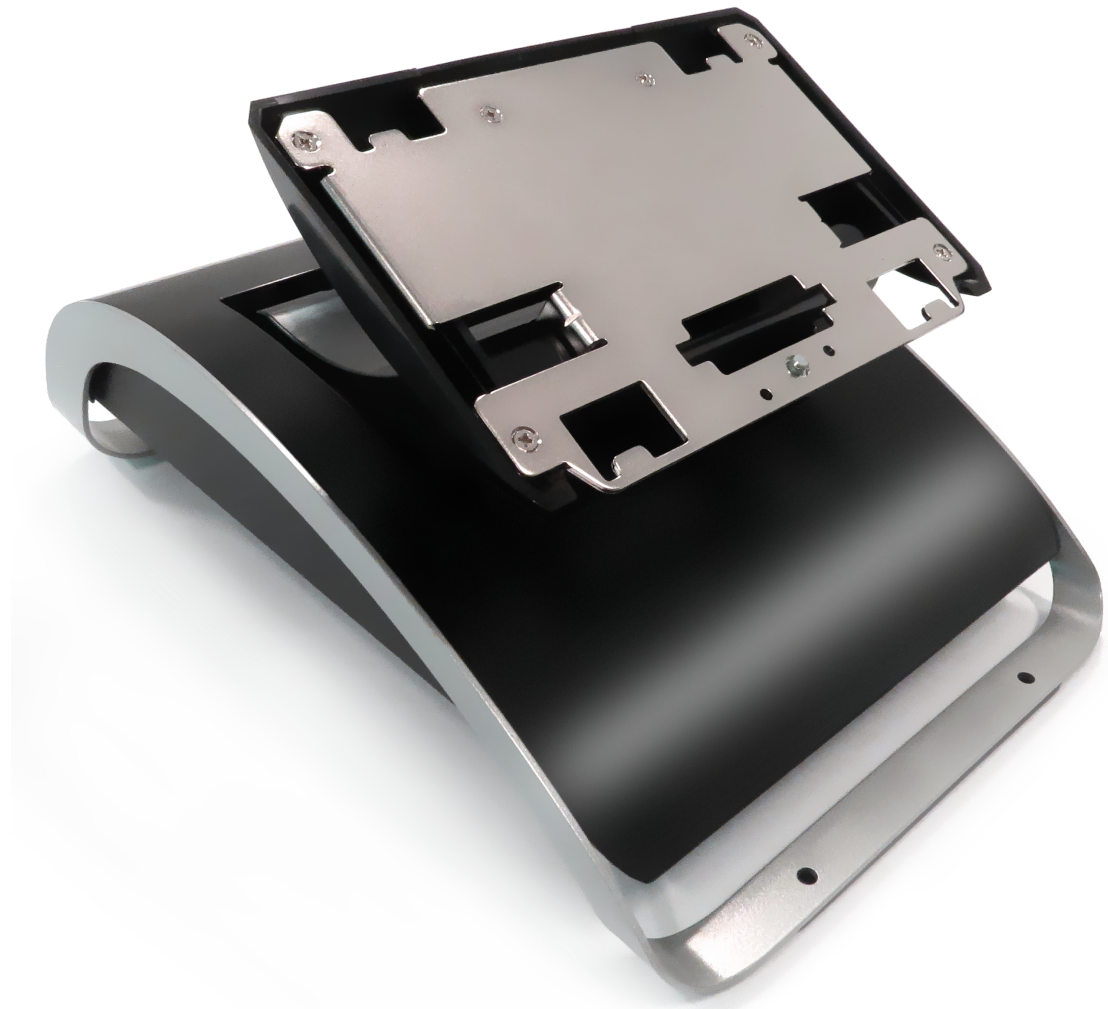

MICROS Basic Stand

The Basic Stand (optional) provides a sturdy, lightweight base for mounting the Compact Workstation 310.

Figure 5-5 MICROS Basic Stand





Figure 5-6 MICROS Basic Stand



MICROS Compact Workstation 310 Accessories

Table 5-4 Oracle MICROS Compact Workstation 310 Accessories

Accessory	Description
<p>Enclosure for Battery (Enclosure for 83 Wh for Oracle MICROS Compact Workstation 3 Series basic and flexible stands) Part Number: 7118514</p>  A black, rectangular enclosure for a battery. It has a textured surface and several screws. A black cable with a connector is attached to the side.	<p>The MICROS Enclosure for Battery (optional) enables you to run the Compact Workstation 310 using battery power. Can be charged using the External Power Supply for Oracle MICROS Compact Workstation 3 Series (Part Number: 7119052).</p>
<p>External Power Supply for Oracle MICROS Compact Workstation 3 Series Part Number: 7119052</p>  A black, rectangular external power supply unit. It has a textured top surface and a power input port on the front. A black power cord is attached to the side.	<p>The External Power Supply supplies power to the Compact Workstation 310 and can charge batteries installed in the Enclosure for Battery.</p>

6

The Oracle MICROS Tablet 700 Series

The Oracle MICROS Tablet 700 Series (Tablet 720, Tablet 721, and Tablet 721P) feature slim yet rugged enclosures, a 7-inch TFT display powered by the Intel Atom quad-core processor, and offers an optimal combination of performance and power savings. It provides integrated Wi-Fi and Bluetooth connectivity, a magnetic stripe reader, an optional barcode scanner, an optional camera (Tablet 721 only), and an optional RFID reader. The Tablet 720 is available with Microsoft Windows Embedded 8.1 Industry Pro or Microsoft Windows 10 IoT Enterprise 2016 LTSC operating systems. The Tablet 721 includes the Microsoft Windows 10 IoT Enterprise 2019 LTSC operating system. The Tablet 721P includes the Microsoft Windows 10 IoT Enterprise 2019 LTSC operating system

MICROS Tablet 700 Series Technical Specifications

The following tables contain the technical specifications for the Oracle MICROS Tablet 720 and the Oracle MICROS Tablet 721.

Table 6-1 Technical Specifications for the Oracle MICROS Tablet 720

Feature	MICROS Tablet 720
Processor	Intel Atom Quad Core, 1.33GHz
RAM	2GB
Storage	64GB Flash
Operating System	Microsoft Windows Embedded 8.1 Industry Pro Microsoft Windows 10 IoT Enterprise 2016 LTSC
Display	7-inch LED-Backlight Screen with Capacitive Touch
Display Resolution	1280 x 800
WLAN	Wi-Fi 802.11a/b/g/n
Bluetooth	Bluetooth 4.0 LE
USB Port	USB 2.0 x 1
Headset Jack	1
DC In	1
AC/DC Adapter	Input: 100 – 240V AC; Output: 5V DC, 3A
Battery Pack	Replaceable rechargeable Li-ion battery, 3.6V, 8800mAh Backup/Bridge Battery: 240mAh
Enclosure	ABS + PC plastics
Dimensions (H x W x D)	5.24in x 8.26in x 0.93in 133mm x 210mm x 23.5mm
Temperature	Operation: 0 °C (32 °F) to 40 °C (104 °F) Storage: -20 °C (-4 °F) to 60 °C (140 °F)

Table 6-1 (Cont.) Technical Specifications for the Oracle MICROS Tablet 720

Feature	MICROS Tablet 720
Humidity	0% to 90% Non-Condensing
Weight	1.31 lbs (0.59 kg)
Magnetic Stripe Reader (MSR)	Triple Track Readers (ISO TK1, 2 & 3), JIS & AAMVA Compliant
Barcode Scanner	Optional; 1D/2D Barcode Scanner
NFC/RFID	Optional; Supports ISO/IEC 14443 Type A, Reader/Writer Mode @ 13.56MHz

Table 6-2 Technical Specifications for the Oracle MICROS Tablet 721/721P

Feature	MICROS Tablet 721/721P
Processor	Intel Atom Quad Core, 1.44GHz
RAM	4GB
Storage	64GB Flash
Operating System	Microsoft Windows 10 IoT Enterprise 2016 LTSB Microsoft Windows 10 IoT Enterprise 2019 LTSC (Tablet 721P)
Display	7-inch LED-Backlight Screen with Capacitive Touch
Display Resolution	1280 x 800
WLAN	Wi-Fi 802.11a/b/g/n/ac
Bluetooth	Dual Mode Bluetooth 4.2, BLE
USB Port	USB x 1
Headset Jack	1
DC In	1
AC/DC Adapter	Input: 100 – 240V AC; Output: 12V DC, 5A
Battery Pack	Replaceable rechargeable Li-ion battery, 3.6V, 8800mAh Backup/Bridge Battery: 240mAh
Enclosure	ABS + PC plastics
Dimensions (H x W x D)	Tablet 721: 5.24in x 8.75in x 0.7in (133mm x 210mm x 18mm) Tablet 721P: 5.41in x 8.49in x 1in (137.5mm x 215.6mm x 26.4mm)
Temperature	Operation: 0 °C (32 °F) to 40 °C (104 °F) Storage: -20 °C (-4 °F) to 60 °C (140 °F)
Humidity	0% to 90% Non-Condensing
Weight	1.31 lbs (0.59 kg)
Magnetic Stripe Reader (MSR)	Triple Track Readers (ISO TK1, 2 & 3), JIS & AAMVA Compliant
Barcode Scanner	Optional; 1D/2D Barcode Scanner

Table 6-2 (Cont.) Technical Specifications for the Oracle MICROS Tablet 721/721P

Feature	MICROS Tablet 721/721P
Camera	Optional; Resolution up to 2592x1944px, 68° FOV, 3.94in minimum focus distance, F2.8±5%
NFC/RFID	Optional; Supports ISO/IEC 14443 Type A/B, ISO/IEC 15693, MIFARE Ultralight, FeliCa, Reader/Writer Mode @ 13.56MHz

MICROS Tablet 720 Features

Figure 6-1 The Features of the MICROS Tablet 720 — Front and Side View



Figure 6-2 The Features of the MICROS Tablet 720 — Back View



Table 6-3 Input/Output Port on the MICROS Tablet 720

Feature	Description
A. Barcode Scanner (Optional)	Captures and reads information contained in a bar code.
B. Magnetic Stripe Reader (MSR)	Reads magnetic stripe cards for employee sign in, authorization, and loyalty programs.
C. Headphone Jack	Use to connect a headphone, a microphone, or a headset.
D. USB 2.0 Port	Use to connect peripherals such as storage devices, printers, and displays.
E. 5V DC Power Input	Use to connect a power adapter to provide power to your tablet and charge the battery.

Table 6-4 Button Functions on the MICROS Tablet 720

Feature	Description
1. Power Button	Turns the tablet on or off.
2. Scanner Trigger	Use to activate the barcode scanner.
3. Battery/Power LED	Indicates the power and battery status. <i>Battery LED Status</i> has more information on the behavior of the LED.
4. Battery Latch	Use to unlock and remove the battery.

Table 6-4 (Cont.) Button Functions on the MICROS Tablet 720

Feature	Description
5. Battery Sensor	Senses the presence of a battery. Located in the battery compartment under the battery. Inadvertently pressing this when the battery is removed disables the “hot swap” capability and causes the tablet to power off.

MICROS Tablet 721/721P Features

The features of the Oracle MICROS Tablet 721 are described below. The Oracle MICROS Tablet 721P includes identical features, plus accessory mounting points and an ultra-rugged exterior.

Figure 6-3 The Features of the Oracle MICROS Tablet 721 — Front and Side View



Figure 6-4 The Features of the Oracle MICROS Tablet 721 — Back View



Table 6-5 Input/Output Port on the Oracle MICROS Tablet 721/721P

Feature	Description
A. Barcode Scanner (Optional)	Captures and reads information contained in a bar code.
B. Magnetic Stripe Reader (MSR)	Reads magnetic stripe cards for employee sign in, authorization, and loyalty programs.
C. Headphone Jack	Use to connect a headphone, a microphone, or a headset.
D. USB Port	Use to connect peripherals such as storage devices, printers, and displays.
E. 12V DC Power Input	Use to connect a power supply to provide power to your tablet and charge the battery.
F. Camera	Use to take photographs.

Table 6-6 Button Functions on the Oracle MICROS Tablet 721/721P

Feature	Description
1. Power Button	Turns the tablet on or off.
2. Scanner Trigger	Use to activate the barcode scanner.
3. Battery/Power LED	Indicates the power and battery status. <i>Battery LED Status</i> has more information on the behavior of the LED.
4. Battery Latch	Use to unlock and remove the battery.
5. Battery Sensor	Senses the presence of a battery. Located in the battery compartment under the battery. Inadvertently pressing this when the battery is removed disables the “hot swap” capability and causes the tablet to power off.

Tablet Accessories

Table 6-7 Oracle MICROS Tablet 700 Series Accessories



Accessory	Description
<p>High Capacity Li-Ion Polymer Battery Part Number 7601701</p> 	<p>Note: The Tablet 720 requires BIOS v0.01.25ORC or greater to support the new Lithium-Ion Polymer battery. Download the BIOS update (patch number 28178739) from https://support.oracle.com.</p> <p>The High Capacity Li-Ion Polymer Battery allows for long use and quick swap without requiring the tablet to be docked. The battery can be charged separately using the 4-Bay Battery Charger or with the Oracle MICROS Tablet 700 Series tablets using the Desktop Charging Cradle, 4-Bay Tablet Charger, or external power adapter.</p>
<p>Power Supply Part Number: 7118431 with C13 power cord connection.</p> 	<p>The Power Supply (12V) is used to charge a single Tablet 721/721P with the battery attached. Not for use with the Tablet 720.</p>
<p>External Power Adapter Part Number: 7117487</p> 	<p>The External Power Adapter (5V) charges a single Tablet 720 with battery attached. Not for use with the Tablet 721/721P.</p>

Table 6-7 (Cont.) Oracle MICROS Tablet 700 Series Accessories

Accessory	Description
4-Bay Battery Charger Part Number: 7118826 with C13 power cord connection	Charges up to 4 batteries at a time.
	
4-Bay Tablet Charger Part Number: 7118827 with C13 power cord connection	Charges up to 4 tablets with batteries attached at the same time.
	
Desktop Charging Cradle Part Number: 7118828 with C13 power cord connection	Charges one tablet with battery attached and one spare battery at the same time.
	

Table 6-7 (Cont.) Oracle MICROS Tablet 700 Series Accessories



Accessory	Description
<p>Payment Device Mount and hand straps for Oracle MICROS Tablet 721P Part Number: 7601705</p> 	<p>The Payment Device Mount lets you mount a PIN entry device on the Tablet 721P.</p> 
<p>Replacement hand straps and mounting brackets for Oracle MICROS Tablet 721 and Oracle MICROS Tablet 721P Part Number: 7601707</p> 	<p>Includes “x-style” and “PED-style” hand straps, plus brackets, screws, and washers for replacing the hand straps on a Tablet 721/721P.</p>
<p>Adjustable Shoulder Straps Part Number: 7605101</p> 	<p>Features adjustable length from 50 inches to 67 inches. Sold in packs of 4 and compatible with the Tablet 721P (not compatible with models Tablet 720 or 721).</p>
<p>LCD screen protectors for Oracle MICROS Tablet 700 Series, pack of 5 Part Number: 7602035</p> 	<p>The LCD screen protector helps defend your Tablet 700 Series screen against scratches and scuffs.</p>

Table 6-7 (Cont.) Oracle MICROS Tablet 700 Series Accessories

Accessory	Description
LCD Screen Protectors, Tempered Glass Part Number: 7605100	The tempered glass screen protector provides enhanced scratch and scuff protection for your Tablet 700 Series screen. Sold in packs of 4 and compatible with models Tablet 720, 721, and 721P.

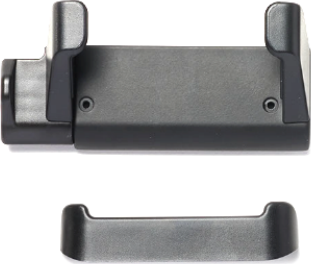

Replacing the Bridge Battery in the MICROS Tablet 720

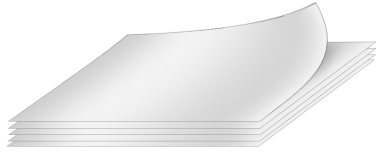
Follow the steps below to replace the bridge battery in the MICROS Tablet 720.

Prerequisites

- #1 Phillips head screwdriver
- Tweezer or needle nose pliers

Procedure

1. Place the tablet face down on a rubberized or cloth surface to prevent scratches.
2. Slide the battery release latch until the main battery detaches from the tablet body. Set the main battery aside.

Figure 6-5 Removing the MICROS Tablet 720 Main Battery



3. Remove the bridge battery cover using a #1 Phillips screwdriver. For some tablets, you may need to peel back the license decal first.

Figure 6-6 Removing the Bridge Battery Cover



4. Carefully remove the battery from the compartment until you can access the connector cable. Use your fingers or a gripping tool to carefully separate the connector. Make sure you hold and pull the plastic connectors and not the wires. After disconnecting the battery, set it aside.

Figure 6-7 Battery Connector Cable

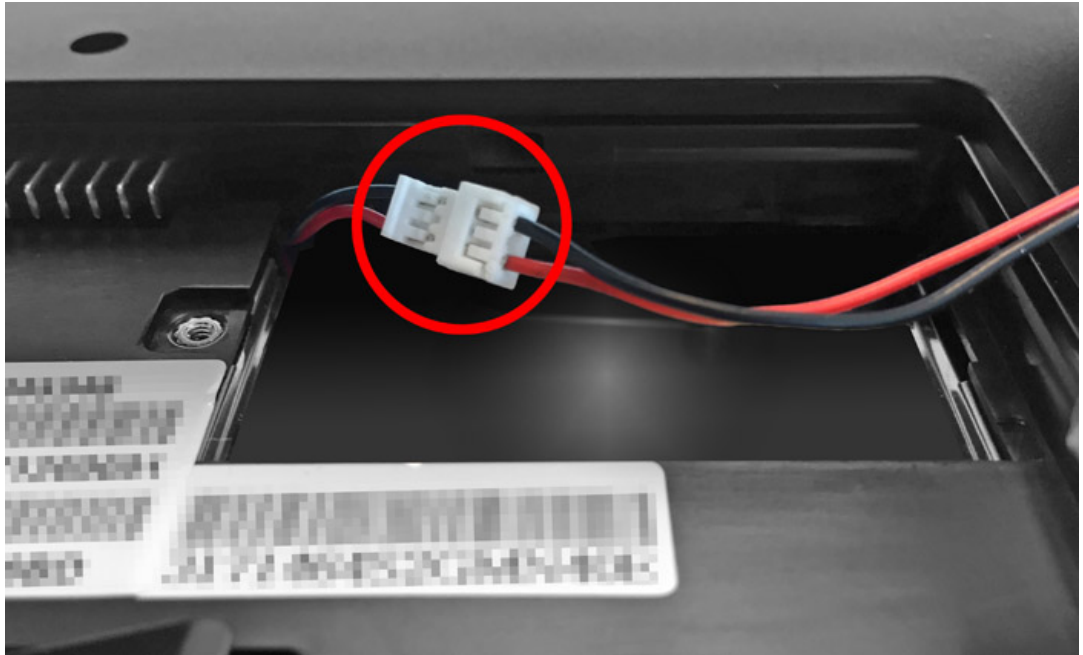

5. Connect the replacement battery. Tuck the excess battery wire into the casework and place the battery in the battery compartment.

Figure 6-8 The Bridge Battery in the Battery Compartment



6. Reinstall the battery cover and hand-tighten the screw.
7. (Optional) Attach the CBR sticker inside the battery bay. The CBR sticker helps identify tablets whose bridge batteries have been replaced.
8. Reinstall the main battery.

7

MICROS Workstation 610, 620, and 650

- The Oracle MICROS Workstation 610 features an Intel® Atom™ processor and runs the Microsoft Windows Embedded 8.1 Industry Pro operating system or the Microsoft Windows 10 IoT Enterprise operating system.
- The Oracle MICROS Workstation 620 features an Intel® Celeron® processor and runs the Microsoft Windows 10 IoT Enterprise operating system.
- The Oracle MICROS Workstation 650 features an Intel® Core™ i5 processor and runs the Microsoft Windows 10 IoT Enterprise operating system.

Each workstation is a Point-of-Sale (POS) terminal featuring a 15.6 inch widescreen high-definition display with a projected capacitive touch screen.

The *Workstation 6 Series Setup Guide* provides instructions for the setup and operation of the Workstation 6 Series hardware.

Figure 7-1 MICROS Workstation 610



MICROS Workstation 610/620/650 Features and Specifications

Table 7-1 Technical Specifications for the MICROS Workstation 610, 620, and 650*

Feature	610	620	650
Processor	Intel Atom E3827 Dual-Core Processor with 1.75GHz Clock Speed	Intel Celeron 3765U Dual-Core Processor with 1.9GHz Clock Speed	Intel i5-5350U Dual-Core Processor with 1.8GHz Base and 2.9GHz Turbo Maximum Clock Speed

Table 7-1 (Cont.) Technical Specifications for the MICROS Workstation 610, 620, and 650*

Feature	610	620	650
Display	15.6 inch Widescreen High Definition (1920x1080 FHD) Display Multi-Touch Projected Capacitive Touchscreen High Definition 2nd Display Output Connector Connector for a Second Display Output		
Memory	2 SODIMM Sockets; DDR3L 1333MHz up to 8GB	2 SODIMM Sockets; DDR3L 1600MHz up to 16G	2 SODIMM Sockets; DDR3L 1600MHz up to 16G
Storage	32 GB or 64 GB MO-297 Slim SATA 2.0 Solid State Drive Standard SD Card Socket	128 GB M.2 SATA 3.0 Solid State Drive Standard MO-297 Slim SATA Solid State Drive (Optional) MO-300 mSATA Solid State Drive Socket (Optional)	256 GB, M.2 SATA 3.0 Solid State Drive Standard MO-297 Slim SATA Solid State Drive (Optional) MO-300 mSATA Solid State Drive Socket (Optional)
Operating System	Microsoft Windows Embedded 8.1 Industry Pro (32-bit only) Microsoft Windows 10 IoT Enterprise (64-bit only)	Microsoft Windows 10 IoT Enterprise (64-bit only)	
Magnetic Card Reader	Modular Integrated 3-Track Magnetic Card Reader; Capable of Hardware Encryption at the Swipe	2 Configurations Available: <ul style="list-style-type: none"> With Modular Integrated 3-Track Magnetic Card Reader; Capable of Hardware Encryption at the Swipe Without Modular Integrated 3-Track Magnetic Card Reader 	
Audio	Intel HD Audio 2 Integrated Stereo Speakers Standard Headphone Output/MIC Input on I/O panel		
Network	10/100/1G RJ45 Ethernet 802.11 a/b/g/n Dual Band Radio w/Bluetooth 4.0 (Optional)		
USB	9 Total: <ul style="list-style-type: none"> 2 USB on I/O Panel 1 USB in Stand 2 USB 2.0 on I/O Panel 1 USB 2.0 12V Powered Header on I/O Panel 3 USB 2.0 Internal 	10 Total: <ul style="list-style-type: none"> 2 USB on I/O Panel 1 USB in Stand 2 USB 2.0 on I/O Panel 1 USB 2.0 12V/1A Powered Header on I/O Panel 3 USB 2.0 Internal 1 Industry Standard 24V/2A Powered USB on I/O Panel 	

Table 7-1 (Cont.) Technical Specifications for the MICROS Workstation 610, 620, and 650*

Feature	610	620	650
Serial Ports	4 Total Standard: <ul style="list-style-type: none"> 2 - RJ45 RS232 Powered (0/5/9/12V Selectable) 1 - RJ45 RS232 1 - RJ45 RS422/RS232 IDN 	3 Total Standard: <ul style="list-style-type: none"> 1 - RJ45 RS232 Powered (0/5/9/12V Powered) 1 - RJ45 RS232 1 - RJ45 RS422/RS232 IDN 	
Adjustable Stand Expansion Modules (Optional)	Powered USB Expansion Module: <ul style="list-style-type: none"> 1 - 24V Powered USB 3 - 12V Powered USB 2 USB 		
Cash Drawer Ports	2 - MICROS Series 2 Cash Drawer Ports 12/24V Selectable		
Customer Display Port	1 - Customer Display Port		
Power Output	1 - 12V Power Out (2.5A)		
Expansion Ports	1 - MICROS Expansion Port 1 - Mini PCI Express Port	1 - MICROS Expansion Port	
Power Supply	Universal Input Auto Switching Power Supply in Adjustable Stand External Universal Input Auto Switching Power Supply for Wall or VESA Mount		
Weight	Head Unit: 7 lbs Adjustable Stand: 5 lbs		
Dimensions	322mm x 398mm x 330mm The Equipment Dimensions section contains more details.		
Operating Temperature and Humidity	0 °C (32 °F) to 50 °C (122 °F) 90% Max Relative Humidity (Non-Condensing)		
Enclosure	Combination of Cast Aluminum, Rugged PC-ABS Plastic Blend, and PC +10% Glass Fiber Spill Resistant Enclosure Passive Cooling (No Fans)		
Certifications	FCC Class A, UL, CE, TUV, RoHS, China RoHS		

*The Workstation 6 Series does not contain a camera. The front-facing opening on the Workstation 6 Series touchscreen border was designed for a front-facing camera; however, this camera was never implemented.

MICROS Workstation 610/620/650 Primary I/O Ports

The Primary I/O Panel contains the following ports:

- 12V Power Output
- 12V Power USB Header

- IDN Port RS422/RS232
- Series 2 Cash Drawer x2The Series 2 ports are more compact than the previous generation and feature an expanded number of pins to accommodate more options on the cash drawer interface. You can use an adapter cable for backwards compatibility to existing cash drawers.
- USB 2.0 x2
- High Definition 2nd Display Output Connector Display Output
- Customer DisplayThe Customer Display port supports existing pole displays and the Workstation 6 integrated customer display.
- USB x2
- 10/100/1G Ethernet
- 24V Power USB (620 and 650 Only)
- RJ-45 Powered Serial (0/5/9/12V)
 - 2 available on the 610
 - 1 available on the 620 and the 650
- RJ-45 Serial
- Microphone In/Headphone Out

Figure 7-2 Primary I/O Panel of the MICROS Workstation 610



Figure 7-3 Primary I/O Panel of the MICROS Workstation 620 and 650

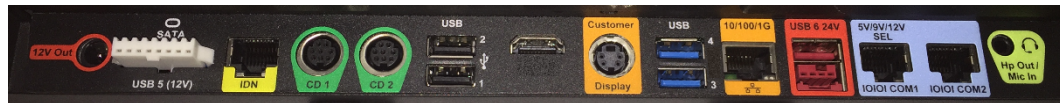

MICROS Workstation 610/620/650 Series Internal I/O Ports

- MICROS Expansion PortThe MICROS expansion port provides connectivity to the system through a number of industry standards, including Serial (UART), SDIO, USB, and PCIe. A standard connector and dedicated footprint provide future-proofing of devices such as wireless modules and storage devices.
- Micro USB 2.0 x3
- Left and Right Speaker Output

Figure 7-4 Workstation 6 Option I/O Ports



Figure 7-5 Workstation 6 MICROS Port

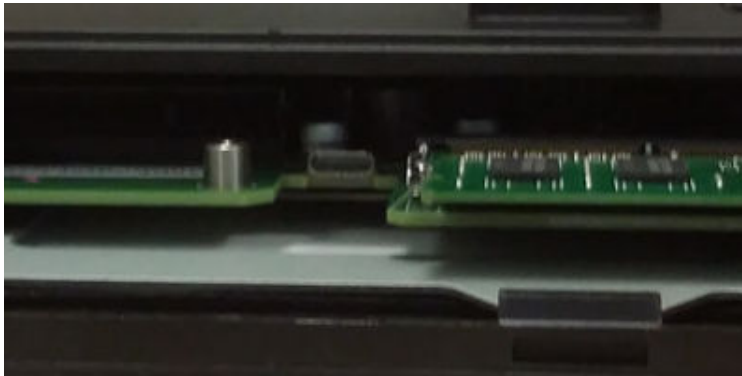

MICROS Workstation 6 Series Adjustable Stand

The Workstation 6 Adjustable Stand provides a solid base for mounting the Workstation 6, a wide range of positioning for optimal viewing angle, enhanced cable management, integrated customer display mounting locations, and expansion options. The adjustable stand contains the following features:

- High- and Low-Mount Customer Displays
- USB Port
- Printer Power Supply Storage/Expansion Module Location
- DC Power Cable
- 3 Security Screws (Hex Socket Cap M3x6 MC Steel - Black)
 - 2 for the cable management cover
 - 1 for the workstation
- Hex Key (2.5mm)

For expansion, the Adjustable Stand includes the following:

- Printer Power Supply Storage

The adjustable stand includes a bracket that allows mounting of the Epson PS-180 Power Supply. An internal "Y" cable provides AC power to the Epson PS-180 Power Supply and Workstation 6 power supply.

- Expansion Module Location

The printer power supply storage location can alternatively be used for optional expansion modules, including a powered USB expansion module. You cannot use an expansion module and the printer power supply at the same time.

8

MICROS Tablet E-Series 8 and E-Series 11

The MICROS Tablet E-Series includes two models, the E-Series 8 and the E-Series 11 available in 8" and 10.8" screen sizes, and each is available with an optional MSR Sleeve.

The *MICROS Tablet and Base Station E-Series Setup Guide* provides instructions for the setup and operation of the E-Series hardware.

Two POS Sleeves are available for the Tablet E-Series 8; one incorporates a 1D/2D Imager/Scanner into the casework.

The Tablet E-Series 11 is a mobile device with an available MSR Sleeve that can also be tethered to the [MICROS Base Station](#) for peripheral, wired Ethernet connectivity, and battery charging.

Figure 8-1 MICROS Tablet E-Series 8 with Sleeve



Figure 8-2 MICROS Tablet E-Series 11 with Sleeve



MICROS Tablet E-Series with MSR Sleeve Features

Table 8-1 MICROS Tablet E-Series with MSR Sleeve Features

Feature	E-Series 8 w/ Sleeve	E-Series 11 w/ Sleeve
Processor	Intel Atom Z3740D Quad Core SoC @ 1.33 GHz (1.83 GHz Turbo), 2M L2 Cache, Intel Gen7 Integrated Graphics	Intel Atom Z3770 Quad Core SoC @ 1.46 GHz (2.39 GHz Turbo), 2M L2 Cache, Intel Gen7 Integrated Graphics
Memory	2GB LPDDR3 SDRAM PC-1333	2GB LPDDR3 SDRAM PC-1333
Storage	32GB eMMC	64GB eMMC
Operating System	Microsoft Windows Embedded 8.1 Industrial Pro	Microsoft Windows Embedded 8.1 Industrial Pro
Display	8.0" IPS Display at 1280x800, Portrait or Landscape orientation, Auto Rotating	10.8" WXGA 1920x1080 HD LCD, Portrait or Landscape orientation, Auto Rotating
Touchscreen	10-Point Capacitive Touch Sensor	10-Point Capacitive Touch Sensor
Magnetic Card Reader	Optional POS Sleeve /w Modular Integrated 3-Track MCR capable of encryption at the swipe	Optional POS Sleeve /w Modular Integrated 3-Track MCR capable of encryption at the swipe
Scanner	Optional Support 1D/2D Imager/Scanner	N/A

Table 8-1 (Cont.) MICROS Tablet E-Series with MSR Sleeve Features

Feature	E-Series 8 w/ Sleeve	E-Series 11 w/ Sleeve
External Connectors & Controls /w MSR Sleeve	<ul style="list-style-type: none"> • Micro USB (charging only) • Headphone/Microphone Jack • Volume Up/Down • Power/Standby Button • Gang Charger Pins • Scanner Trigger Button (Optional Scanner) 	<ul style="list-style-type: none"> • Micro USB (charging only) • Headphone/Microphone Jack • Volume Up/Down • Power/Standby Button • Gang Charger Pins • Multi-Function Docking Connector for Base Station
Network	802.11 a/b/g/n Dual Band Wi-Fi with WPA, WPA2, TKIP, AES support Bluetooth 4.0	802.11 a/b/g/n Dual Band Wi-Fi with WPA, WPA2, TKIP, AES support Bluetooth 4.0
Card Reader	Micro SD (SD, SDHC, SDXC - 64GB max)	Micro SD (SD, SDHC, SDXC - 64GB max)
Battery	2-Cell Lithium-Ion 18Wh	2-Cell Lithium-Ion 32Wh
Operating Temperature	0°C (32°F) to 35°C (95°F)	0°C (32°F) to 40°C (104°F)
Storage Temperature	-10°C (14°F) to 45°C (113°F)	-10°C (14°F) to 45°C (113°F)
Weight	400g (0.88lb)	726g (1.7lb)
Dimensions	Length: 216mm (8.51 inches) Width: 130mm (5.11 inches) Thickness: 9 mm (0.35 inches)	Length: 280mm (11.02 inches) Width: 177mm (6.97 inches) Thickness: 10.2 mm (0.40 inches)
Certifications	FCC Class A, UL, CE, TUV, RoHS, China RoHS	FCC Class A, UL, CE, TUV, RoHS, China RoHS

MICROS Tablet E-Series 8 with MSR Sleeve Connectors

The figures below display front and back views of the MICROS Tablet E-Series 8 and E-Series 11 along with their respective MSR Sleeve.

Figure 8-3 MICROS Tablet E-Series 8 with MSR Sleeve Features and Connectors



Figure 8-4 MICROS Tablet E-Series 11 with MSR Sleeve Features and Connectors



9

MICROS Tablet R-Series

The MICROS Tablet R-Series is a 10.1” (1024x600) Wi-Fi based tablet with a standard TFT LCD and available daylight viewable LCD. The Tablet R-Series is also available in a concessions version that permanently resides on the [MICROS Base Station](#).

The *MICROS Tablet and Base Station R-Series Setup Guide* provides instructions for the setup and operation of the R-Series hardware.

Figure 9-1 MICROS Tablet R-Series



MICROS Tablet R-Series Features

Table 9-1 MICROS Tablet R-Series Features

Feature	Specifications
Processor	Freescale i.MX6 Dual Core Processor ARM Cortex A9 Architecture 1GHz, 1MB L2 Cache

Table 9-1 (Cont.) MICROS Tablet R-Series Features

Feature	Specifications
Display	10.1" WVGA (1024x600) TFT LCD /w LED Backlights Portrait or Landscape orientation and Auto-Rotation Two LCD options are available: <ul style="list-style-type: none"> • Standard 10.1" LED backlit TFT LCD • Daylight readable TFT based on adaptive LCD technology.
Operating System	Windows Embedded Compact 7
Touchscreen	Truly Projected Capacitive Touch Sensor that supports multi-touch and gesturing
Memory	1GB DDR3 SDRAM
Storage	4G Fixed NAND Flash 8G microSD Flash Card
Backlight	LED backlights with three intensity setting controlled by the Automatic Light Sensor or API
Case Material	Magnesium Alloy, PC-ABD, and Nylon materials Spill and drop resistant
Weight	830 grams (1.8 lbs.)
Physical Dimensions	16mm D, 176mm W, 292mm H (0.62 in x 6.90 in x 11.5 in)
Mag Stripe Reader	Modular Integrated 3-Track card reader capable of encryption at the swipe.
Ports	Charging Pins (for MICROS Tablet Multi-Unit Charger) Multi-function connector for Base Station (All signals between Tablet and Base Station)
Network	802.11 a/b/g/n Wi-Fi with WPA WPA2, TKIP, AES support Bluetooth V2.01 Wi-Fi/Bluetooth not available on Concessions Tablet
Battery	Embedded Lithium Ion (21.8Wh) Embedded Battery not available on Concessions Tablet
Input Power	5 VDC, 2.5A
BTU/Hour	120 Typical, 290 Maximum
Operating Temperature	-10°C (14°F) to 60°C (140°F) When Charging Battery: 0°C (32°F) to 45°C (113°F)
Storage Temperature	-25°C (-13°F) to 85°C (185°F)
Certifications	FCC Class A, UL, CE, TUV, RoHS, China RoHS

MICROS Tablet R-Series Connectors

Figure 9-2 MICROS Tablet R-Series Features and Connectors



10

MICROS Base Station

When the MICROS Tablet R-Series or E-Series 11 is plugged into the Base Station, it provides the ports required to drive peripherals such as cash drawers, printers, barcode scanners, customer displays, and coin changers, plus connectivity to a wired Ethernet.

The *MICROS Tablet and Base Station R-Series Setup Guide* and the *MICROS Tablet and Base Station E-Series Setup Guide* provide instructions for the setup and operation of the Base Station hardware.

Figure 10-1 MICROS Tablet R-Series Base Station



Figure 10-2 MICROS Tablet E-Series Base Station



MICROS Base Station Features

Table 10-1 MICROS Base Station Features

Feature	Specifications
Display	MICROS Tablet R-Series or Tablet E-Series 11
Case Style	Supports Tablet in Left-or-Right Landscape or Portrait mode
Weight	/w Tablet: 2.60 kg (5.75 lb.) /w Tablet and Optional Smart Battery: 3.08 kg (6.80 lb.)
Physical Dimensions	See Appendix A
Optional Customer Display (Series 2)	Integrated or Pole 240x64 STN Graphics LCD Integrated 2x20 LCD Protégé Pole Customer Display System
Serial Ports	<ul style="list-style-type: none"> • 2 DB9 Powered RS232 /w handshake <ul style="list-style-type: none"> – COM1 (5V/9V/12V User Selectable) – COM2 (12V) • 1 Modular RS232 Serial /w handshake (COM5) • 1 Modular IDN Serial (RS232 or RS422) • 1 Customer Display Port
USB Ports	<ul style="list-style-type: none"> • 2 USB 2.0 • 2 USB • 1 MICROS Powered USB
Network	10/100/1000 Mbps Ethernet - RJ45
Battery	79Wh Lithium Ion Smart Battery

Table 10-1 (Cont.) MICROS Base Station Features

Feature	Specifications
Input Power	25 Watts
AC Input Voltage	Universal Input - 85 to 264VAC, 47 to 63Hz.
BTU/Hour	120 Typical, 290 Maximum
Operating Temperature	-10°C (14°F) to 60°C (140°F) When Charging Battery: 0°C (32°F) to 45°C (113°F)
Storage Temperature	Without Battery: -25°C (-13°F) to 80°C (176°F) □ With Battery: -20°C (-4°F) to 60°C (140°F)
Certifications	FCC Class A, UL, CE, TUV, RoHS, China RoHS

MICROS Base Station Connectors

The figure below shows the Base Station Modular COM ports and 8-Pin Mini-DIN Cash Drawer connectors.

Figure 10-3 Base Station Modular and Smart Cash Drawer Connectors

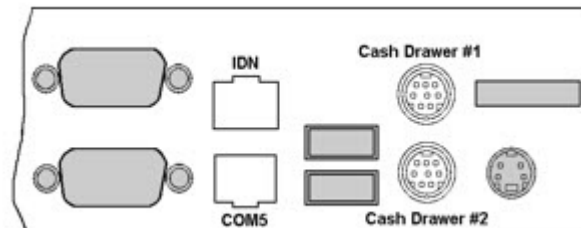

The Cash Drawer Conversion Cable, PN 300290-020-PT, adapts a MICROS Cash Drawer with 4-pin DIN connector to Base Station.

11

MICROS Tablet Multi-Unit Charger

The Multi-Unit Charger is a dedicated charging station for the MICROS Tablet R-Series and E-Series 8. It consists of a charging base and multiple cradles. A maximum of eight charging cradles fit on the charging base and are mounted facing left or right to maximize accessibility. For the Tablet R-Series, each cradle includes a pair of LED indicators to monitor charging. The unit can be mounted on a wall or secured on a counter surface.

The *Installing the MICROS Tablet Multi-Unit Charger Kit* document provides installation instructions for the Multi-Unit Charger.

Figure 11-1 MICROS Tablet Multi-Unit Charger with 4 R-Series Charging Cradles



MICROS Tablet Multi-Unit Charger Features

Table 11-1 MICROS Tablet Multi-Unit Charger Features

Feature	Specifications
Charging Indicator	R-Series Only – a pair of LEDs in each cradle displays the charging status
Case Style	Wall or Counter Mounted Charging Base that supports a maximum of 8 Charging Cradles
Weight	Shipping Weight = 4.5 kg (10 lbs.) With 4 Tablets = 11.3 kg (25 lbs.) With 8 Tablets = 15.9 kg (35 lbs.)
Physical Dimensions	The Equipment Dimensions section contains more information.
Input Power	40W Typical, 130W max /w 8 Tablets
AC Input Voltage	Universal Input - 85 to 264VAC, 47 to 63Hz.
Operating Temperature (Charging)	0°C (32°F) to 45°C (113°F)

Table 11-1 (Cont.) MICROS Tablet Multi-Unit Charger Features

Feature	Specifications
Storage Temperature	-25°C (-13°F) to 85°C (185°F)
Certifications	FCC Class A, UL, CE, TUV, RoHS, China RoHS

12

MICROS PC Workstation 2015

The MICROS PC Workstation 2015 resembles the Workstation 5A but adds support for one or two SATA disk drives along with two processors selected from the Intel Calpella Platform.

The *PC Workstation 2015 Setup Guide* provides instructions for the setup and operation of the PC Workstation 2015 hardware.

Figure 12-1 MICROS PC Workstation 2015



MICROS PC Workstation 2015 Features

Table 12-1 PC Workstation 2015 Features

Features	Specifications
Processor	Intel Celeron P4505 1.86Ghz Dual Core/Dual Thread Intel Core i5-520E 2.4Ghz Dual Core/Quad Thread with Intel VPro Technology
Display	Standard 1024x768 15" TFT Color LCD
Operating System	Microsoft POS Ready 2009
Memory	2 SO-DIMM Sockets - Max 8GB DDR3 1066
Storage	2.5" SATA Solid State Drive (SSD) 2G Standard
Case Style	Standard Low Profile or Optional Adjustable Stand
Case Material	PC-ABS Plastic
Weight	13.2 lbs. (6.0 kg), Shipping Weight 17.6 lbs. (7.9 kg)
Physical Dimensions	See Appendix A

Table 12-1 (Cont.) PC Workstation 2015 Features

Features	Specifications
Optional Customer Displays (Series 1)	Integrated or Pole 240x64 STN Graphics LCD Integrated or Pole Protégé Customer Display System
Cash Drawers	2 MICROS 4-Pin DIN Connectors - +12V or +24V selectable in BIOS.
COM Ports	<ul style="list-style-type: none"> • 1 DB9 RS232 Serial (COM1 - Powered (5V, 9V, or 12V - Selectable in BIOS) • 1 DB9 RS232 Serial (COM2 - Non Powered) • 1 Modular RS232 (COM5) • 1 Combination RS232/RS422 (COM4)
USB Ports	Four USB 2.0 Ports
Powered USB Ports	<ul style="list-style-type: none"> • Two MICROS Powered USB Ports • USB5 (+5V, +12V, +24V) - USB6 (+5V, +12V)
LAN Interface	10/100/1000 Mbps Ethernet - RJ45
AC Input Voltage	Universal Input - 85 to 264VAC, 47 to 63Hz.
Input Power	35W Typical
BTU/Hour	120 Typical, 290 Maximum
Operating Temperature	0°C (32°F) to 45°C (113°F), 90% relative humidity max.
Storage Temperature	-25°C (-13°F) to 80°C (176°F)

MICROS PC Workstation 2015 Connectors

The figure below shows the PC Workstation 2015 Modular COM ports.

Figure 12-2 PC Workstation 2015 I/O Panel Modular Connectors

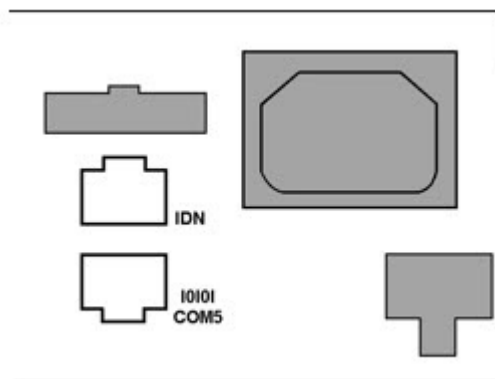

13

MICROS PC Workstation 2010

The PC Workstation 2010 is the predecessor to the PC Workstation 2015. It has an adjustable-display design with a standard 12.1" or optional 15" LCD and features either an Intel Celeron or Intel Pentium M processor.

The *PC Workstation 2010 Setup Guide* provides instructions for the setup and operation of the PC Workstation 2010 hardware.

Figure 13-1 MICROS PC Workstation 2010



MICROS PC Workstation 2010 Features

Table 13-1 MICROS PC Workstation 2010

Feature	Specifications
Processor	<ul style="list-style-type: none">• Intel Pentium M745 2M 400Mhz• Intel Celeron M320 512K 400Mhz
Display	Standard 800x600 12.1" TFT Color LCD, Optional 1024x768 TFT Color LCD
Operating System	Windows XP Professional
Memory	DDR-SDRAM: (2) Slots, 128 MB up to 2 GB
Case Style	Adjustable Display
Case Material	PC-ABS Plastic
Weight (/w Hard Disk and VFD Display)	With 12.1" LCD - 17 lbs. (7.7 Kg) With 15 LCD - 22.7 lbs. (10.3 Kg)

Table 13-1 (Cont.) MICROS PC Workstation 2010

Feature	Specifications
Physical Dimensions	The Equipment Dimensions section contains more information.
Optional Customer Displays (Series)	Pole 240x64 Graphics Capable Display with 2x20 emulation.
Cash Drawers	2 MICROS 4-Pin DIN Connectors - +12V or +24V Jumper Selectable.
LAN Interface	10/100 Mbps BaseT Ethernet
COM Ports	<ul style="list-style-type: none"> • 1 DB9 RS232 Serial • 2 Modular RS232/RS422
USB Ports	4
AC Input Voltage	Universal 90-264VAC, 47-63GHz.
Input Power	46W Typical, 242W Maximum
Operating Temperature	0°C (32°F) to 45°C (113°F), 90% relative humidity max.
Storage Temperature	-25°C (-13°F) to 80°C (176°F)

MICROS PC Workstation 2010 Connectors

The figure below shows the PC Workstation 2010 modular COM ports.

Figure 13-2 MICROS PC Workstation 2010 Connectors

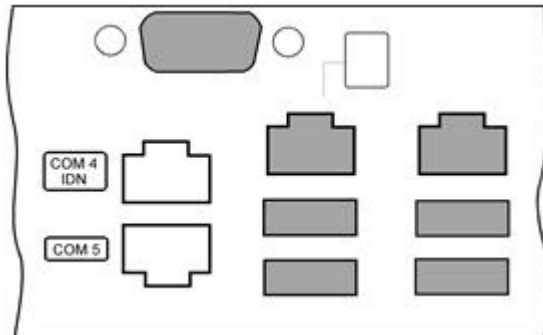

MICROS Workstation 5A

The Workstation 5A is a fan-less Windows Embedded CE 6.0 client and is also capable of running POSReady 2009. Based on the same casework as the WS5, it uses a System Board with an Intel Atom N450 Processor for improved performance. The Operator LED is white to distinguish the 5A from the original Workstation 5 blue. The figure below shows the low-profile workstation and the workstation installed on an optional adjustable.

The *Workstation 5A Setup Guide* provides instructions for the setup and operation of the Workstation 5A hardware.



MICROS Workstation 5A Features

Table 14-1 MICROS Workstation 5A Features

Features	Specifications
Processor	Intel Atom N450, Single Core, 1.6GHz
Display	Standard 1024x768 15" TFT Color LCD
Operating System	Windows CE 6 or POSReady 2009
Memory	2 SO-DIMM Sockets - Max 2 GB DDR2 667
Case Style	Standard Low Profile or Optional Adjustable Stand
Case Material	PC-ABS Plastic
Weight	10.5 lbs. (4.7 kg) / Shipping Weight 14.0 lbs. (6.35 kg)
Physical Dimensions	The Equipment Dimensions section contains more information.

15

MICROS Workstation 5

The Workstation 5 is a diskless/fan-less embedded workstation that can run either Windows Embedded CE 6.0 or POS Ready 2009. The figure below shows the low-profile workstation and the workstation installed on an optional adjustable.

The *Workstation 5 Setup Guide* provides instructions for the setup and operation of the Workstation 5 hardware.

Figure 15-1 MICROS Workstation 5



MICROS Workstation 5 Features

Table 15-1 MICROS Workstation 5 Features

Feature	Specifications
Processor	AMD Geode LX800
Display	Standard 15" 1024x768 TFT Color LCD
Operating System	Windows Embedded CE 6.0
Memory	2 DDR 333 DIMM sockets – 2 GB Max
Case Style	Standard Low Profile or Optional Adjustable Stand
Case Material	PC-ABS Plastic
Physical Dimensions	The Workstation 5 and 5A Equipment Dimensions section contains more information.

Table 15-1 (Cont.) MICROS Workstation 5 Features

Feature	Specifications
Optional Customer Displays (Series 1)	Integrated or Pole 240x64 STN Graphics Capable LCD Integrated or Pole Protégé Customer Display System
Cash Drawers	2 MICROS 4-Pin DIN Connectors - +12V or +24V available
COM Ports	<ul style="list-style-type: none"> • 1 DB9 RS232 • 2 Combination RS232/RS422
USB Ports	4
LAN Interface	10/100/1000 Mbps Ethernet - Modular RJ45
AC Input Voltage	Universal Input - 85 to 264VAC, 47 to 63Hz
Input Power	24W Typical
BTU/Hour	83 Typical
Operating Temperature	0°C (32°F) to 45°C (113°F), 90% relative humidity max.
Storage Temperature	-24°C (-13°F) to 80°C (176°F)

MICROS Workstation 5 Connectors

The figure below shows the Workstation 5 Modular COM ports

Figure 15-2 Workstation 5 I/O Panel Modular Connectors

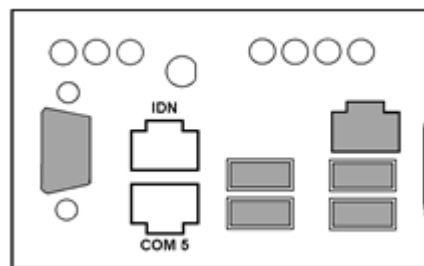

16

MICROS Workstation 4 LX

The Workstation 4 LX is a diskless/fan-less embedded terminal based on Windows CE .NET. The figure below shows the low-profile workstation and the workstation installed on an optional adjustable.

The *Workstation 4LX Setup Guide* provides instructions for the setup and operation of the Workstation 4LX hardware.

Figure 16-1 MICROS Workstation 4 LX



MICROS Workstation 4 LX Features

Table 16-1 MICROS Workstation 4 LX Features

Feature	Specifications
Processor	AMD LX800
Display	Standard 800 x 600 12.1" TFT color LCD touchscreen
Operating System	Windows Embedded CE 6.0
Memory	256M DDR333 DIMM
Case Style	Standard Low Profile or Optional Adjustable Stand
Case Material	PC-ABS Plastic
Weight	7.7 lbs. (3.5 kg) / Shipping Weight 11 lbs. (5 kg)
Physical Dimensions	The Equipment Dimensions for the Workstation 4 LX section contains more information.

Table 16-1 (Cont.) MICROS Workstation 4 LX Features

Feature	Specifications
Optional Customer Displays (Series 1)	Integrated or Pole 240x64 STN Graphics Capable LCD Integrated or Pole Protégé Customer Display System
Cash Drawers	2 MICROS 4-Pin DIN Connectors - +12V or +24V selectable in the BIOS.
COM Ports	<ul style="list-style-type: none"> • 1 DB9 RS232 • 1 Modular RS232 • 2 Combination RS232/RS422
USB Ports	4
LAN Interface	On Board Mbps 10/100/1000 - RJ45
Input Voltage	Universal Input - 85 to 264VAC, 47 to 63Hz.
Input Power	23W Typical, 65W Max
BTU/Hour	80 Typical, 222 Maximum
Operating Temperature	0°C (32°F) to 45°C (113°F), 90% relative humidity max.
Storage Temperature	-24°C (-13°F) to 80°C (176°F)

MICROS Workstation 4 LX Connectors

The figure below shows the Workstation 4 LX Modular COM ports.

Figure 16-2 Workstation 4 LX I/O Panel Modular Connectors

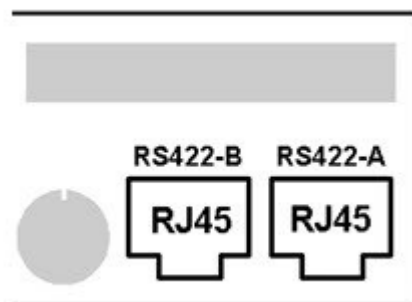

MICROS Keyboard Workstation 270

The MICROS Keyboard Workstation 270 (KW270) is a low-power diskless Windows CE workstation based on a Freescale Semiconductor ARM processor. Designed for high volume applications in indoor and outdoor environments, it features a rugged membrane keyboard and supports a wide range of operating temperatures.

The *Keyboard Workstation 270 Setup Guide* provides instructions for the setup and operation of the KW270 hardware.



MICROS Keyboard Workstation 270 Features

Table 17-1 MICROS Keyboard Workstation 270 Features

Feature	Specifications
Processor	FreeScale iMX27L
Display	5.7" 320x240 Operator LCD
Operating System	Windows Embedded CE 6.0
Memory	128M Mobile DDR SDRAM
Case Style	Standard Low Profile or Optional Adjustable Stand
Case Material	PC-ABS Plastic
Weight	7.7 lbs. (3.5 kg) / Shipping Weight 11 lbs. (5 kg)
Physical Dimensions	The KW270 Equipment Dimensions section contains more information.
Customer Display	Integrated 2x20, LCD
Optional Customer Displays	Pole 240x64 Graphics Capable LCD

Table 17-1 (Cont.) MICROS Keyboard Workstation 270 Features

Feature	Specifications
Cash Drawers	2 MICROS 4-Pin DIN Connectors - +12V or +24V jumper selectable.
Serial IO Ports	<ul style="list-style-type: none"> • 1 DB9 RS232 (Jumper Selectable 9V or 12V) • 1 Modular RS232 • 2 Combination RS232/RS422
Accessory Power	<ul style="list-style-type: none"> • 1 +9VDC @ 1.5A • 1 +12VDC @ 2.5A
USB Port	2 USB Ports
LAN Interface	10/100 Mbps Ethernet - RJ45
Input Voltage	Universal Input - 85 to 264VAC, 47 to 63Hz.
Input Power	6W Typical, 63W Maximum (+15VDC @ 4.2A) External AC Adapter
Operating Temperature	<p>Without Battery Pack: -10°C (14°F), to 65°C (149°F), 90% relative humidity non-condensing at 65°C (149°F).</p> <p>With Battery Pack: Charging: 0°C (32°F) to 45°C (113°F) Discharging: -10°C (14°F) to 60°C (140°F)</p>
Storage Temperature	<p>Without Battery Pack: -20°C (-4°F) to 80°C (176°F)</p> <p>With Battery Pack: -5°C (23°F) to 30°C (86°F)</p>

MICROS Keyboard Workstation 270 Connectors

The figure below shows the KW270 Modular COM ports.

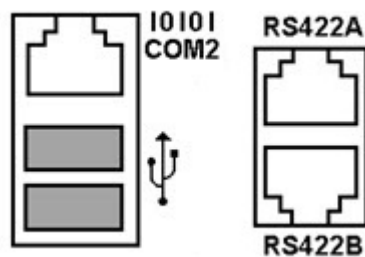

18

Order Confirmation System

The Order Confirmation System consists of the in-store Order Confirmation Controller (OCC) connected to the curbside Remote Display Pedestal. The OCC transmits VGA display data to the Remote Pedestal over twisted pair UTP cable. It is based on Windows Embedded CE 6.1 and supports an optional VGA monitor.

The *Order Confirmation System Setup Guide* provides instructions for the setup and operation of the OCC hardware.

Figure 18-1 Order Confirmation System

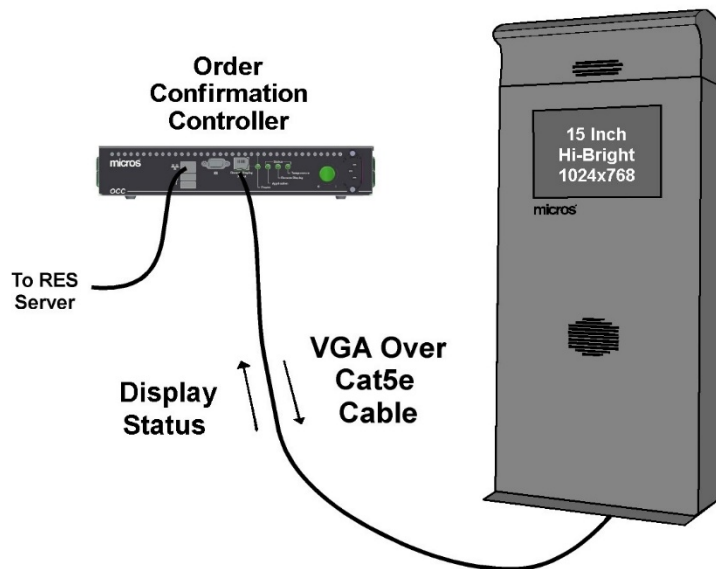

Order Confirmation Controller (OCC) Features

Table 18-1 Order Confirmation Controller Features

Feature	Specifications
Display	Local VGA and or Remote Display Unit
Case Material	Sheet Metal
Physical Dimensions	The Order Controller Equipment Dimensions section contains more information.
Shipping Weight	7.7 lbs. (3.5 Kg)
USB Port	2
Serial Port	1 RS485 Half-Duplex Serial Channel to Remote Display Unit

Table 18-1 (Cont.) Order Confirmation Controller Features

Feature	Specifications
LAN Interface	10/100/1000 Mbps Ethernet - Modular RJ45
AC Input Voltage	Universal Input - 85 to 264VAC, 47 to 63 Hz.
Input Power	13W Typical
Operating Temperature	0°C (32°F) to 45°C (113°F), 90@ relative humidity max
Storage Temperature	-25°C (-13°F) to 80°C (176°F)

Remote Display Unit Features and Requirements

Table 18-2 Remote Display Unit Features

Feature	Specifications
Display	15" (1024x768) TFT High-Bright LCD, 262K Colors Max
Case Material	Aluminum 5052
Physical Dimensions	The Order Confirmation Remote Display Equipment Dimensions section contains more information.
Shipping Weight	23.25 lb. (10.7 Kg)
Serial Port	1 RS485 Half-Duplex Serial Channel to OCC.
LAN Interface	None
Input Power	120VAC +/- 10%, 47 to 63Hz The RDU Heater and Pedestal Fans are 120 VAC Only
Operating Temperature	-20°C (-04°F) to 65°C (149°F), 90% Relative Humidity Max
Storage Temperature	-25°C (-13°F) to 80°C (176°F)

Order Confirmation System Installation

The Order Confirmation System is composed of an in-store Order Confirmation Controller (OCC) attached to a curb-side Remote Display Pedestal for drive-through applications. Refer to [Order Confirmation Controller Equipment Dimensions](#) section for detailed dimensions of the pedestal and base plate.

Order Confirmation Controller (OCC) Requirements

The Order Confirmation Controller requires a Category 6 or better cable run and face plate. The [AC Power Requirements](#) are the same as a MICROS workstation.

The OCC can be placed on a shelf or mounted to a wall with the included wall bracket. [Order Confirmation Controller Equipment Dimensions](#) includes dimensional drawings of the unit and wall mount bracket.

Remote Display Pedestal Requirements

Listed below are the site preparation requirements for the Remote Pedestal. The [Equipment Dimensions](#) section includes dimensional drawings for the Pedestal and the pre-attached base plate

Concrete Slab

A 0.23" (6mm) thick base plate is affixed to the pedestal to provide a stable platform. Mount the base plate to a 1/2" thick concrete slab, roughly the same dimension as the base plate. An opening for conduit egress is located at the center of the base plate.

For new installations, a minimum of four studs (supplied by the installer) projecting from the slab is required.

Figure 18-2 Pedestal Slab Example

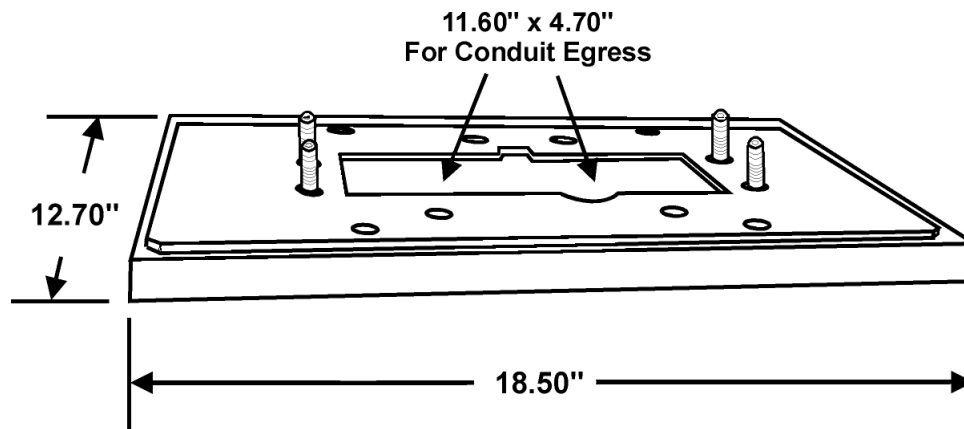

Conduit Runs

The pedestal requires three independent conduits, AC Power, Audio, and VGA over Cat 5e cable.

For new installations, Oracle MICROS recommends that three ferrous metal conduits (as defined in [AC Power Requirements](#) section) be run to the slab through the opening in the base plate.

Alternately, the conduits can enter the pedestal from outside the enclosure. The figure below displays the locations of the 1" OD conduit punch-outs – on the front, back, and sides of the pedestal.

Figure 18-3 Pedestal Alternate Conduit Entry Dimensions

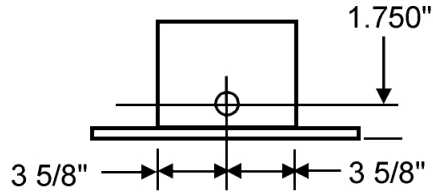

Conduit Inlet Left/Right Side

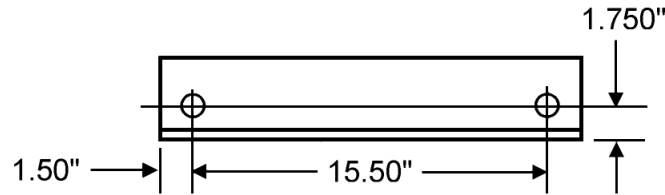

Conduit Inlet - Front/Rear

Conduit - AC Power

Ensure the AC line is installed in accordance with the Preferred AC Power System as defined in [AC Power Requirements](#) section.

Conduit - Audio

The Audio Conduit is reserved car detection and audio between the pedestal and store. The in-store audio system is currently installed by third parties. The Pedestal provides industry standard mounting locations for the speaker and microphone.

Conduit - VGA over Category 5e Cable

Ensure one conduit is dedicated to the Category 5e or better cable run from the in-store OCC. Therefore, a minimum of Category 5e cable run is required between the OCC to the Remote Pedestal location. Ensure this cable is installed, terminated, and certified in the same manner as any Cat 5e cable run.

Pedestal AC Outlet

An AC outlet is required within the pedestal housing. The figure below shows the area available in the Pedestal that is used to mount the outlet box. Local electrical codes may require a Ground Fault Interrupter (GFI) outlet to be mounted at least two feet above ground level in areas prone to flooding.

The preferred method is to mount the outlet box directly to conduit, positioned at a height above ground level that meets local electrical codes.

Figure 18-4 Pedestal AC Outlet - Recommended AC Outlet Location

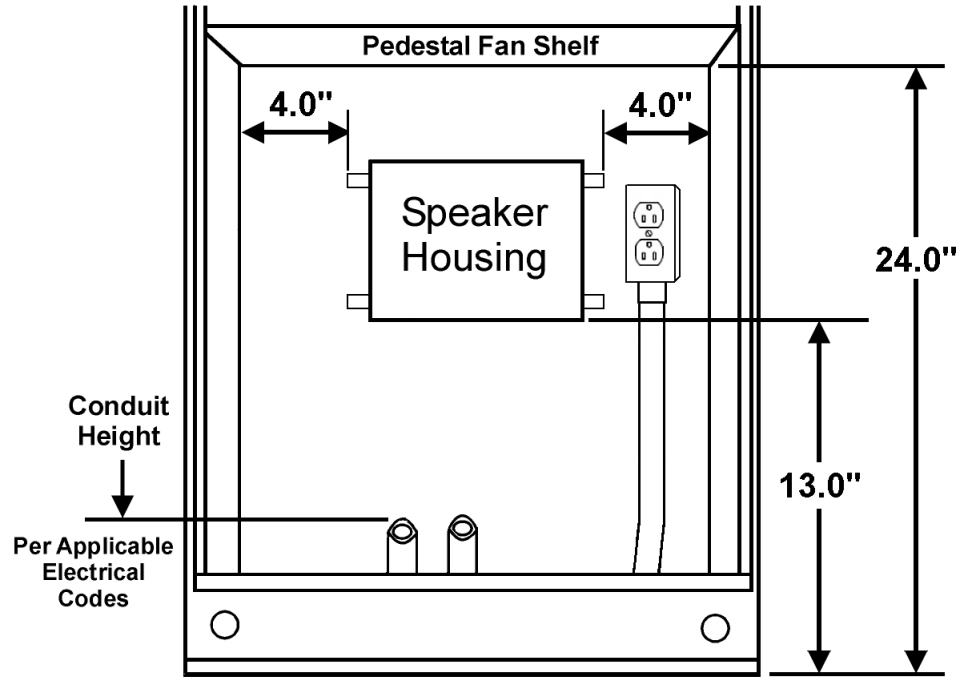

19

e7 BOC or Digital Menu and Marketing System Controller

The Lanner EM-F345 is a fan-less embedded system based on the Intel Atom N270. It is currently used as the e7 Back Office Controller (BOC) or the Digital Menu and Marketing System Controller (DDC).

The *Digital Menu & Marketing System Setup Guide* provides instructions for the setup and operation of the DDC hardware.

Figure 19-1 Digital Menu and Marketing System Controller



e7 BOC Features and Requirements

Table 19-1 e7 BOC Features

Feature	Specifications
Processor	1.6GHz Atom
Display	1 VGA Port, 1 DVI-D Port (Dual Display)
Operating System	POSReady 2009
Case Material	Sheet Metal
Weight	2.5 lbs. (1.07 Kg)
Physical Dimensions	145mm D, 190mm W, 36mm H
Mounting	Depends on Application
COM Ports	2 RS232/RS485/RS435
USB Ports	4
LAN Interface (2)	10/100/1000 Mbps Ethernet - Modular RJ45
AC Input Voltage	100 - 240VAC - 1.5A, 50 - 60Hz.
Input Power	60W Max

Table 19-1 (Cont.) e7 BOC Features

Feature	Specifications
Operating Temperature	With Industrial Temp CF, Memory, and AC Adapter: -20°C (-4°F) to +50°C (122°F) With 2.5" Hard Disk Drive: 0°C (32°F) to 40°C (104°F)
Storage Temperature	-20°C (-4°F) to 70°C (158°F)

20

Printing Devices

A number of printing devices using a variety of interfaces are supported for such tasks as printing guest checks, order receipts, time cards, and reports.

From the site preparation perspective, three types of printers are supported – Ethernet, RS232, and IDN. Connect all printers using the Preferred AC Power System referenced in the [AC Power Requirements](#) section.

Ethernet

The Ethernet Module can be installed in any supported printer and supported by most Oracle Hospitality application software. Also referred to as IP Printing, these printers are connected to Ethernet in the same manner as a workstation (e.g., faceplates and patch cables at each location) as described in the [Cable Requirements](#) section.

RS232

The RS232 Module can be installed in any supported printer and connected directly to a workstation.

MICROS Integrated Device Network (IDN)

When using the IDN Module, all supported printers are connected to a MICROS IDN port. The following rules apply:

- A Local IDN Printing device is connected directly to the workstation with an IDN patch cable.
- A Remote IDN network consists of a workstation driving one or more devices connected in a daisy chain over twisted pair cable at distances of up to 4000 feet from the workstation. This configuration requires in-wall cable runs, faceplates, and patch cables at the workstation driving the network and as well as each device.

In addition, cabling the IDN is implemented in one of two ways:

- Traditional MICROS IDN connection hardware and faceplates and MICROS approved RS422 twisted pair cable.
- Shielded Category 6 or better cabling and faceplates with MICROS IDN to ANSI/EIA/TIA-568-A patch cables.

The [Cable Requirements](#) section describes the IDN installation process using the above methods.

21

Peripheral Devices

With the exception of the Customer Displays and Cash Drawers, the peripheral devices listed below are connected to the Workstation through a RS232 interface.

10-Inch Customer Display

The 10-Inch Customer Display shows transaction totals and status. When a check is paid, the display shows the amount tendered and any change due. The 10-Inch Customer Display is compatible with the Oracle MICROS Workstation 6 Series.

Both high-mount and pole displays are available.

Table 21-1 Technical Specifications for the 10-Inch Customer Display

Feature	10-Inch Customer Display
Display Resolution	Up to 1280 x 800 @ 60Hz
Aspect Ratio	16:10
Viewing Angle	Horizontal: ±85° or 170° total / Vertical: ±85° or 170° total
Input Voltage	12VDC +/- 5%; 100-240VAC, 50/60Hz
Assembled Dimensions and Weight	10-Inch Customer Display with Pole Mount: 22 x 10.02 x 3.65 in/ 558.8 x 254.5 x 92.71 mm; 3.63 lbs/ 1.65 kg 10-Inch Customer Display with High-Mount: Up to 14.25 x 15.5 x 16 in/ 361.95 x 393.7 x 406.4 mm; adds ~1.75 lbs/ 0.79 kg to workstation/stand weight
Temperature and Humidity	Operation: 0°C to 40°C / 32°F to 104°F; Humidity: 20% to 80%

Customer Display

The customer display shows transaction totals and status. When a check is paid, the display shows the amount tendered and any change due.

Both integrated and pole displays are available.

- Series 1 Integrated and Pole Displays:
 - Series 1 displays are supported by the Workstation 5, 5A, PCWS 2015, and KW270.
 - 240x64 STN Graphics capable LCDs with 2x20 emulation mode text capability.
- Series 1 Integrated or 6 inch pole mounted Protégé Customer Display System:
 - The Protégé is an intelligent customer facing display based on a 7 inch 800x400 Color LCD.
 - The Protégé is compatible with many current workstations.
- Series 2 Integrated and Pole Displays:

- Matches the colors and styling of the MICROS Workstation 6, MICROS Tablets, and MICROS Base Stations. The following displays are available.
 - * 240x64 STN Graphics capable LCDs with 2x20 emulation mode text capability.
 - * 2x20 Text LCD.
- Series 1 and 2 Integrated Customer Displays:
 - Both are supplied assembled with the appropriate mounting bracket.
 - The Series 1 Pole displays are available in sizes of 6 and 18 inches.
 - The Series 2 pole display is available in a size of 18 inches.
 - The Series 1 and Series 2 pole display bases use the same hole-pattern. Mounting hardware is not supplied.
 - The APG 4000 Series Cash Drawers include the customer display base hole-pattern.

Cash Drawer

A Workstation can have one or two Cash Drawers attached. Standard and Low Profile Cash Drawers are available. Programming determines which keys and employees have access to each drawer. Cash Drawers can also be locked or opened in emergencies with a cash drawer key.

Barcode Reader

A barcode reader is used to scan an item's barcode or UPC (Universal Product Code) label so an employee can record and post sales.

Coin Changer

A coin changer is a device that issues the coin portion of a customer's change when the customer pays a check or transaction. The coin changer increases the employee's speed (no coins to count) and reduces mistakes caused by giving incorrect change. The Telequip T-Flex Coin Dispenser is available with an RS232 Interface and matching charcoal casework.

Magnetic Card Reader

All MICROS Workstations and Tablets use a 3-Track American Bankers Association (ABA) compatible magnetic stripe reader. It is used to read customer credit cards and MICROS employee cards. Employee cards are used to sign employees on a workstation and enter manager authorization ID numbers.

Scale

A scale is used with menu items that are priced by weight. The software can be programmed to calculate weight in pounds or kilograms. Oracle MICROS recommends the Mettler Toledo Ariva with RS232 interface and the Mettler Toledo Ariva-S-Mini with RS232 interface.

Order Confirmation and Payment Terminal

Oracle MICROS currently uses the customer-facing MX800 series of devices from VeriFone.

Kitchen Display System (KDS)

The RES KDS system is composed of the Restaurant Display Controller (RDC) or the Kitchen Display Controller (KDC) 210, server based software, and one or more PC based clients coupled with touch or non-touch based LCD monitors and bumpbars that act as remote video displays.

A typical KDS system is composed of the RDC or KDC 210, LCD touch monitor or non-touch LCD monitor, and MICROS 10 or 20 Key Wired or Wireless Bumpbars.

Figure 22-1 KDS Components

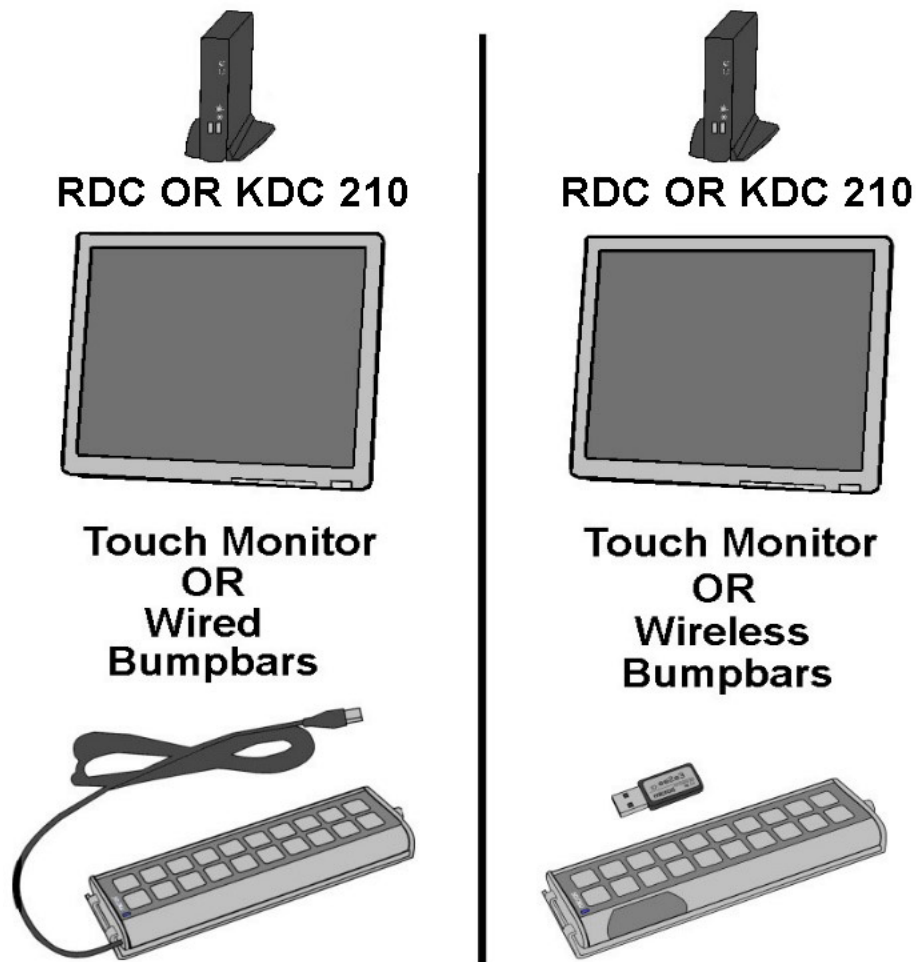

Kitchen Display System Installation

The Kitchen Display System is composed of three components: an Ethernet-based controller (the Restaurant Display Controller [RDC] or the Kitchen Display Controller [KDC] 210), LCD monitor, and wired or wireless MICROS bumpbars.

Figure 22-2 Typical KDS Monitor Bumpbar and Mounting Bracket

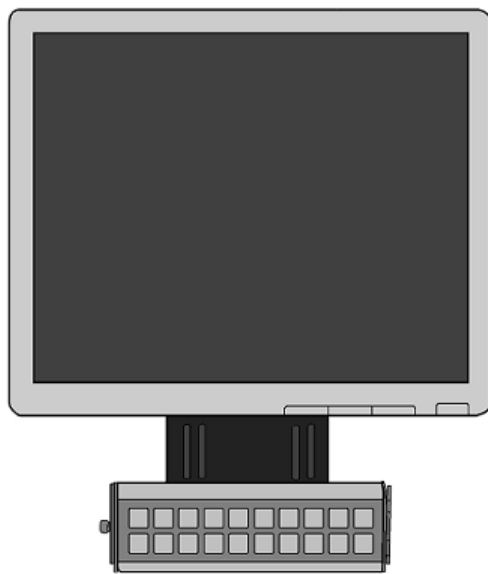

KDS Mounting

A wide variety of LCD and bumpbar mounting options are available. Contact your Oracle MICROS representative if the LCD mounting options need to be determined.

KDS Controllers

KDS Controllers (the Restaurant Display Controller and the Kitchen Display Controller 210) require a Cat 6 faceplate and patch cable near each location. Refer to the *Oracle MICROS Kitchen Display Controller 210 Quick Reference Guide* for detailed information about the KDC 210.

MICROS Wired Bumpbar Installation Considerations

The *MICROS Bumpbar MBB-10 and MBB-20 User Guide* contains information for installing the wired bumpbar.

The MICROS Wired Bumpbar is supplied with a 6ft. (1.8M) cable. The 11 foot cable is also available (PN 700503-070-PT).

MICROS Wireless Bumpbar Installation Considerations

The *MICROS Wireless Bumpbar MBB-10 and MBB-20 User Guide* contains information for installing the wireless bumpbar.

Before installing the mounting brackets, consider the following site related issues to ensure the best possible functionality from the MWBB in an active RF environment.

- **Range**

Distances up to 30 feet are possible when the dongle and bumpbar are within sight of each other, with no obstructions in the path of the RF signals.

As the number and type of obstructions between the dongle and bumpbar increase, the range decreases.
- **Classification of RF Obstructions**

RF signals encounter two types of obstructions that either weaken or reflect the signal, depending on its material composition.

The first type of obstruction is one that allows the signal to pass through, but attenuates, or weakens it. Some examples include walls constructed of wood, drywall, people, and concrete block. The amount of attenuation is proportional to the total thickness of materials that the RF signal must penetrate when traveling the line-of-sight path.

The second type of obstruction is one that reflects the RF signals, allowing little or none to pass through. The reflected RF energy can cause interference even when the dongle and bumpbar are located within line-of-sight. Any type of metallic substance falls into this category. This includes objects such as stainless steel food preparation areas, walk-in freezers, steel doors, and steel support beams.
- **Local RF Interference**

The RF signals emitted by the MWBB are located in the unlicensed 2.40 - 2.50 GHz ISM band. Nearby occupants of this band include microwave ovens (2.485 GHz), 802.11 b/g Wi-Fi, cordless phones, IEEE 802.15.4 (WPAN), ZigBee, and other personal area networks. Ensure the MWBB is located as far from these devices as possible.

The greater the distance between the dongle and the bumpbar, plus the greater the number of obstructions between the two devices, allows extraneous RF devices to impact the operation of the wireless bumpbar.

In cases where the site is too noisy in terms of RF interference, Oracle MICROS recommends the use of the MBB-10 and MBB-20 wired Bumpbars.

e7 Kitchen Video Monitor Controller

The e7 application utilizes the new e7 Kitchen Video Monitor (KVM) Controller. The figure below shows the components of this system including the host workstation, touch screen monitor or standard monitor with wired or wireless bumpbars, e7 KVM Controller, and optional printer.

The host Workstation and e7 KVM Controller are connected in one of two ways:

- Ethernet - The host Workstation and e7 KVM Controller connect through an Ethernet switch.
- RS232 Serial - The host Workstation and e7 KVM Controller connect through an available serial port (DB9, RJ45 COM, or the IDN port).

See the [Cable Requirements](#) section for more details on connecting the e7 KVM Controller serial interface to the host Workstation.

The host workstation is configured to drive a serial printer such as the TM U220. The e7 KVM Controller receives the print data over the Ethernet or Serial interface and reformats it into the selected display format.

The e7 KVM features three display configurations:

- 4 * 1 displays four tables with 22 lines available on each table.
- 4 * 2 displays eight tables with 8 lines available on each table.
- Split screen with two 4 * 1 displays 4 tables from one device and four tables from another device each with 8 lines available.

Orders are displayed as they are received (First-in-First-Display), with up to eight orders displayed at a time. If more than eight orders arrive before any are completed, they are buffered and appear as existing orders are completed. The scroll bar can be used to view the off screen orders.

If the order contains more lines that can fit in the allotted space, it continues into the next allotted space with a clear indication that the order is a continuation.

Each order displays the elapsed time (in MM:SS format), starting from when the e7 KVM controller receives the order. When an order is manually bumped or printed, the average processing time is displayed in the right corner of the screen.

If a power failure occur, all orders are backed up in flash memory. By pressing one finger on the touch screen and moving to the left, the history order window appears. The history order displays in last-in-first-list format (i.e., the latest bumped/printed order appears at the top of the list).

For bumping completed orders, options include a touch screen monitor or a standard monitor with MICROS 2x20 Wired or Wireless Bumpbars. The touch screen monitor or bumpbars connect to one of four USB ports on the e7 KVM Controller.

Optionally, a serial printer can be added and requires a USB to RS232 DB9 Serial Cable to connect to the KVM Controller.

Figure 23-1 e7 Kitchen Video Monitor System

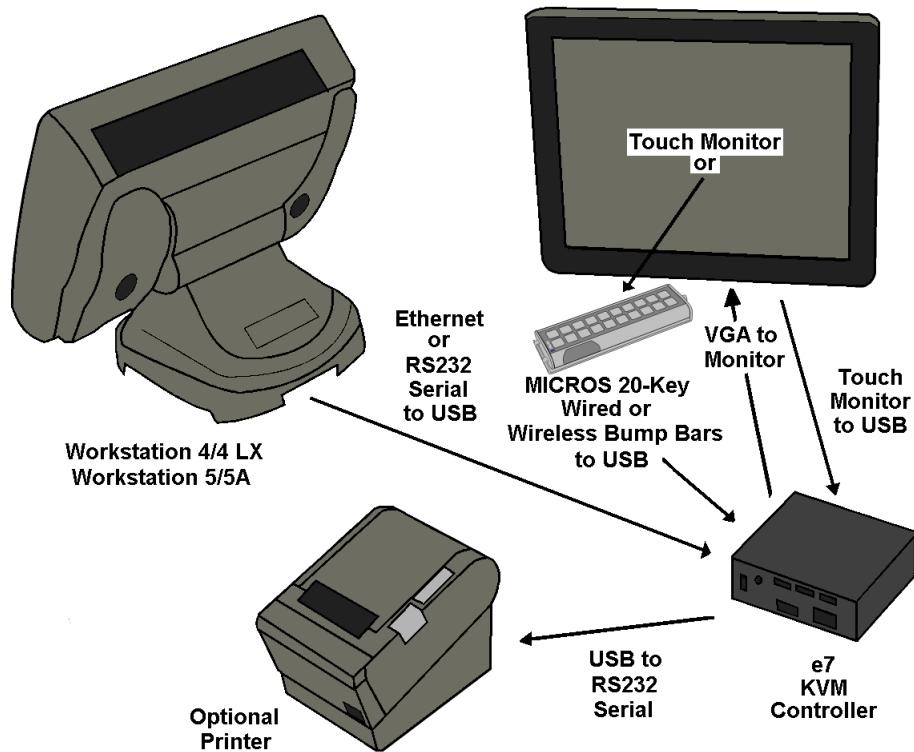

e7 KVM Controller Features and Requirements

Table 23-1 e7 KVM Controller Features

Feature	Specifications
Case Material	Aluminum
Weight	3.5 lbs. (1.5 kg)
Physical Dimensions	84mm D, 95mm W, 38mm H (3.30" x 3.70" x 1.50")
Mounting	Shelf
Video Output	VGA
COM Ports	None
USB Ports	4 Type A, 1 Micro-B
LAN Interface	10/100/1000 Mbps Ethernet - Modular RJ45
External AC Adapter Input Voltage	100 - 240VAC, 50/60Hz, 0.5A
DC Input Voltage	5VDC, 2.5A
Operating Temperature	0°C (32°F) to 50°C (122°F)
Storage Temperature	-20°C (-4°F) to 70°C (158°F)

e7 Kitchen Video Monitor (KVM) Installation

The figure below describes how to implement a serial interface between the host Workstation and e7 KVM Controller.

The Null Modem Cable is required. PN 700503-032-PT is 10 feet in length. Cable pin-outs for the Null Modem Cable and RJ45 to DB9 adapters are provided in the installation document and [Null Modem Cable for e7 KVM Controller](#) section. This cable can be extended to at least 50 feet (15.24m) if required.

The USB to RS232 DB9 M/M (Male-to-Male) PN 700503-089-PT is also required for a serial interface. Note that the e7 KVM Controller includes a driver specific to this cable; similar USB to RS232 DB9 Adapter Cables from other suppliers may not function.

Figure 23-2 Example of Serial Interface to the e7 KVM Controller

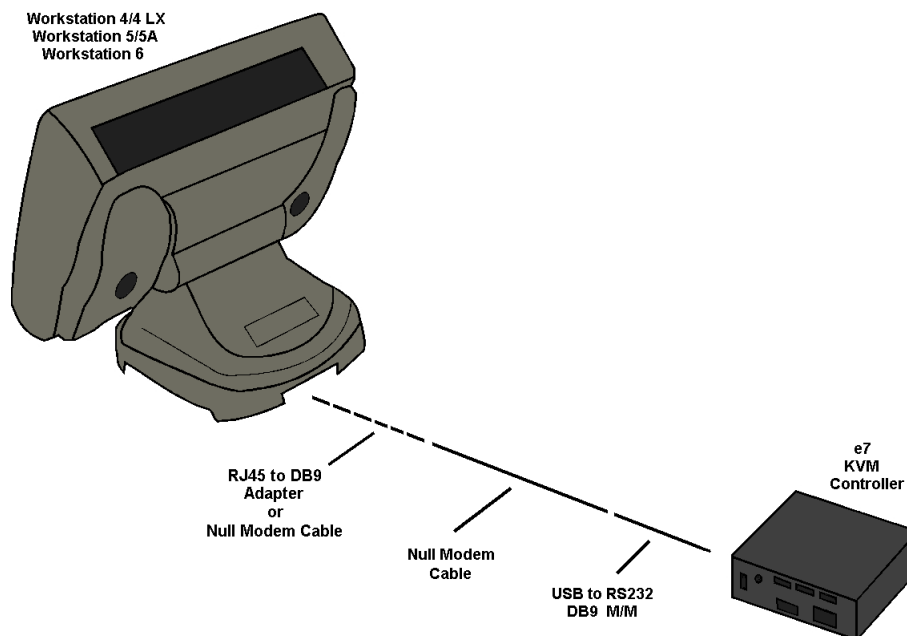

When using the DB9 port, the Null Modem cable connects directly to the workstation, so the RJ45 to DB9 Adapter is not required.

One DB9 port is available on the Workstation 4, 4 LX, 5, and 5A, two DB9 ports are available on the Base Station, and up to three option DB9 ports are available on the Workstation 6. If a DB9 port is not available, a modular RJ45 port can be used, but this requires an additional cable adapter.

Using the COM2 or COM5 port requires RJ45 to DB9 adapter, PN 300319-103-PT, in addition to the other cables. COM2 and COM5 are RJ45 serial ports with full handshake capability.

Using the IDN or one of the RS422-A/RS422-B port requires RJ45 to DB9 adapter, PN 300319-102-PT in addition to the other cables.

One IDN port is available on the Workstation 5, 5A, and Base Station. Two ports, labelled RS422-A and RS422-B, are available on the Workstation 4 and 4 LX and are functionally equivalent to the IDN port. One RJ45 RS232 port, one RJ45 RS422/RS232 (IDN) port, and two RJ45 RS232 powered ports are available on the Workstation 6.

Pin Diagrams for the Null Modem Cable, RJ45 to DB9 adapters, and workstation ports can be found in the [Null Modem Cable for e7 KVM Controller](#) section.

Environmental Requirements and Equipment Placement Considerations

This chapter provides an overview of the environmental requirements for the Oracle MICROS POS equipment during operation and storage.

To ensure proper operation of the equipment, follow these environmental guidelines for equipment placement:

Location

Locate all equipment so that it is accessible to service personnel.

Tile is the recommended floor surface for areas surrounding the equipment. If the floor covering adjacent to the equipment is carpeted, an anti-static grade is recommended.

If the carpeting surrounding the area housing the equipment is not composed of anti-static material, the use of static discharge mats is recommended. The recommended type of anti-static mat is one that incorporates a grounding clip with a cable, to attach the grounding electrode to earth ground.

The [Equipment Dimensions](#) section contains dimensional information for each hardware device in the system.

Foreign Materials

Liquid spillage can cause damage to the circuits in the MICROS workstations and peripherals. Do not place the equipment near food preparation areas, glass racks, or water stations.

Another source of potential hazard to the equipment, especially printers, is solid matter, including paper clips, staples, or any other metallic objects. Safeguards should be taken to prevent the accidental dropping of any such materials into the equipment.

Noise Induction

In addition to the AC Power requirements outlined in [AC Power Requirements](#), eliminate other sources of electromagnetic interference to ensure the trouble-free operation of the equipment.

Noise radiating from AC power lines throughout a site can be absorbed by MICROS AC power and communications lines and induced into the equipment. Therefore, do not run exposed cable dedicated to the MICROS equipment in the vicinity of any AC power lines.

Electrostatic Discharge

Electrostatic discharge (ESD) usually takes the form of a discharge from the operator's hand to the cash drawer, printer, or key switches. ESD is more common in dry climates during winter and less common in moist climates.

Oracle MICROS hardware is tested to high levels of electrostatic discharge, exceeding industry standards.

Humidity

A constant humidity between 40% and 80% is desired for the proper operation of the equipment.

Custom Cabinets and Enclosures

To maintain the internal temperature within the equipment at the specified levels, adequate ventilation is required. Do not mount the equipment in an enclosure that could impede air flow to all four sides. A three sided (front and back open) enclosure with 4 inches of clearance on all sides is acceptable.

Temperature

Operating and storage temperatures for Oracle MICROS workstations are listed below.

Table 24-1 – Operating and Storage Temperatures for Current MICROS Workstations

Device	Operating Temperature	Storage Temperature
Compact Workstation 310/310R	310: 0°C (32°F) to 50°C (122°F) 310R: -10°C (14°F) to 60°C (140°F)	310/310R: -25°C (-13°F) to 85°C (185°F)
Tablet 700 Series	0°C (32°F) to 40°C (104°F)	-20°C (-4°F) to 60°C (140°F)
Workstation 6	0°C (32°F) to 50°C (122°F)	-25°C (-13°F) to 80°C (176°F)
Workstation 5A, 5, and 4 LX	0°C (32°F) to 45°C (113°F), 90% relative humidity max	-25°C (-13°F) to 80°C (176°F)
PCWS 2015 and 2010	0°C (32°F) to 45°C (113°F), 90% relative humidity max	-25°C (-13°F) to 80°C (176°F)
KW270	Without Battery Pack: -10°C(14°F) to 65°C (149°F) 90% relative humidity non condensing at 65°C (149°F) With Battery Pack: Charging: 0°C (32°F) to 45°C (113°F) Discharging: -10°C (14°F) to 60°C (140°F)	Without Battery Pack: -20°C (-4°F) to 80°C (176°F) With Battery Pack ¹ : -5°C (23°F) to 30°C (86°F)
MICROS Tablet	-10°C (14°F) to 60°C (140°F) When Charging Battery: 0°C (32°F) to 45°C (113°F)	-25°C (-13°F) to 85°C (185°F)
Concessions Tablet (No Battery)	-10°C (14°F) to 60°C (140°F)	-25°C (-13°F) to 85°C (185°F)
MICROS Tabletw/ Base Station	Without Battery Pack: -10°C (14°F) to 60°C (140°F) When Charging Tablet or optional Base Station Battery Pack: 0°C (32°F) to 45°C (113°F)	Without Battery Pack: -25°C (-13°F) to 80°C (176°F) With Battery Pack ¹ : -5°C (23°F) to 30°C (86°F)

Table 24-1 (Cont.) – Operating and Storage Temperatures for Current MICROS Workstations

Device	Operating Temperature	Storage Temperature
Order Confirmation Pedestal Remote Display Unit	-35°C (-31°F) to 65°C (149°F)	-35°C (-31°F) to 80°C (176°F)

¹See the [Lithium Ion Battery Pack Storage Considerations](#) section for more details about storing batteries.

Lithium Ion Battery Pack Storage Considerations

The optional Lithium-Ion Totex Battery pack capacity degrades over time. The mechanisms for capacity loss do not require the battery to be charged or discharged; capacity loss can also occur during storage.

In general, capacity loss during storage can be minimized by removing the fully charged battery pack from the equipment and storing it at the lowest possible temperature for the shortest period of time. The storage environment must be low in humidity and free of corrosive gases.

If the battery pack is fully charged, removed from the equipment, and stored at 20°C (68°F) or less, then it should have maximum shelf life of six months. If the storage temperature exceed 20°C (68°F) over a six month period, the shelf life is reduced and we recommend that the battery pack be recharged every 30-60 days.

If storing the battery for less than 30 days, the ideal temperature is between -10°C (-14°F) and 35°C (95°F)

If storing the battery pack for greater than 30 days, but less than one year, the ideal temperature is -5°C (23°F) to 30°C (86°F)

Avoid storing the battery pack for extended period of time at temperatures greater than 45°C (113°F). If the battery is stored at temperatures exceeding 45°C (113°F) for six months, capacity loss is as great as 10%.

AC Power Requirements

This chapter describes the AC power requirements for the Oracle MICROS hardware. MICROS workstations are based on highly sophisticated hardware components that are designed to provide efficient and trouble-free operation.

Proper installation of the AC power and grounding system is essential to minimize the possibility of interference and enhances the performance and reliability of the hardware.

Preferred AC Power System

All power conductors and equipment grounding conductors must be isolated from other power circuits in the facility to ensure that electrical noise produced by other equipment does not create interference for the system hardware.

To accomplish this, install a power distribution panel intended for the sole use of the MICROS hardware. Do not use this dedicated panel to supply other electrical loads in the facility. Run the panel's feeder supply directly from the main source panel for the facility.

Figure 25-1 Preferred AC Power System Panel Wiring

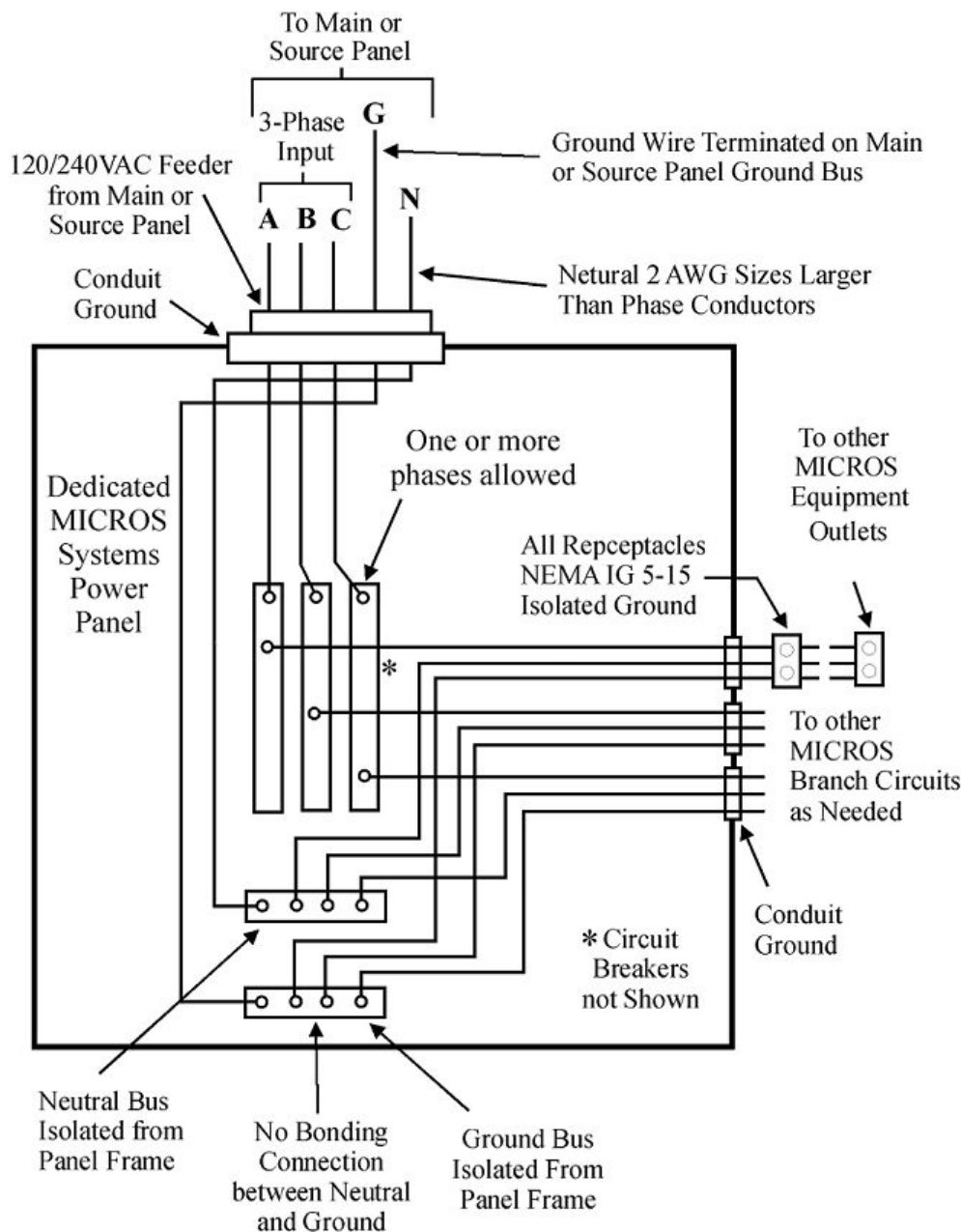

This figure illustrates the preferred AC power system panel wiring. All branch circuits include a separate neutral and equipment grounding conductor unless otherwise indicated. Consult the [AC Power Consumption](#) section to determine the maximum number of computers, workstations, and devices powered from a single circuit.

Notes on the Preferred AC Power System:

- The figure above does not supplant national, state, or local electrical codes.
- Install each Branch Circuit in a dedicated ferrous metal conduit with separate neutral and ground conductors. Aluminum conduit is not acceptable.
- If the length of a branch circuit exceeds 100 feet, increase all conductors (including ground) one wire size for each additional 100 feet of length.

- The neutral conductor from the main or source panel to the dedicated MICROS panel is two sizes larger than the phase conductors. The larger wire size is necessary to accommodate the third harmonic current caused by the switching power supplies in the MICROS equipment. It also minimizes the possibility of common mode noise occurring on the power distribution circuits.
- Install all power distribution circuits in a dedicated ferrous metal conduit that contains only the MICROS supply and ground conductors.
- Install all data communication cables in separate ferrous metallic conduits. The [Cable Requirements](#) section provides information about installing the data communications cables.
- Ensure all [AC Power Receptacles](#) are the isolating ground type. Install according to the specifications in the AC Power Receptacles Grounding section.
- For Servers, an Oracle MICROS-approved Uninterruptable Power Supply (UPS) is required.

Despite the proper installation of the Preferred AC Power System, it is possible to have power problems resulting from the power company or from other equipment in the building. If this occurs, use the Oracle MICROS-approved Power Conditioners to correct.

AC Power System Grounding

This section contains AC system grounding options for the Oracle MICROS hardware.

MICROS Power Panel Grounding

1. Install the insulated equipment grounding conductor (sized the same as the supply conductors) in the same conduit as the supply conductors from the main or source panel to the dedicated MICROS panel.
2. Terminate this equipment grounding conductor on the ground bus in the main panel.
3. At the MICROS-equipment panel, install a ground bus that is electrically isolated from the panel frame, and then terminate the feeder equipment grounding conductor on this bus bar.
4. Use the metallic feeder conduit as the equipment grounding system for grounding the AC power panel frame, metallic conduit system, and metallic junction boxes.

MICROS Branch Circuit Grounding

For each branch circuit from the dedicated power panel to the device receptacles, include a full size (same as supply conductors) insulated equipment grounding conductor installed in the same conduit as the supply conductors. Ensure the conduit is dedicated to MICROS equipment. Terminate this isolated grounding conductor on the isolated ground bus bar in the panel and on the equipment grounding terminal of a NEMA IG5-15 isolated grounding type receptacle.

AC Power Receptacles Grounding

In order to maintain isolation of the equipment grounding conductor from the conduit system, use an isolated ground receptacle. This type of receptacle (usually identified by an orange face) provides an insulating barrier between the equipment grounding terminal and the receptacle mounting strap. Terminate all branch circuits from the MICROS power panels with isolated ground receptacles.

Standard receptacles bond the equipment grounding terminal (green screw) to the receptacle mounting strap and metallic conduit when the receptacle is mounted to the box. This defeats the purpose of the isolated grounding system. Do not install an equipment bonding jumper from the receptacle grounding terminal to the outlet box. (NEC Article 250-74, Exception 4 permits the installation of the isolated ground receptacles and isolated equipment grounding conductors specified in this section.)

If a duplex receptacle is installed and only one socket is used, disconnect the unused socket to prevent the temptation of using the outlet for equipment that produces extraneous ground currents (e.g., floor buffers, blenders, vacuum cleaners, etc.). The correct isolated ground receptacle types are listed below.

Table 25-1 – Isolated Ground Receptacles

Receptacle Type	NEMA Part Number
125V, 15A, Simplex	IG5-15R1
125V, 15A, Duplex	IG5-15R2

Additional Methods for AC Power

This section provides alternate methods of supplying AC power to the MICROS POS System.

Relaxed/Power Conditioned AC Power System

When providing the Preferred AC Power System is cost prohibitive and/or would require major structural changes, we have defined a relaxed AC Power System based on Oracle MICROS Approved Power Conditioners. **However, the Preferred AC Power System is recommended by Oracle MICROS.**

The Relaxed/Power Conditioned AC Power System is described as follows:

- MICROS-approved Power Conditioners are required at all MICROS equipment locations.
- MICROS-approved Uninterruptable Power Conditioners (UPC) are required at each server.
- Ensure all MICROS AC Power branch circuits originate from the same Non-Dedicated Power Panel. Ensure this Panel is equipped with an isolated ground bus that is electrically isolated from the panel frame. Install an insulated equipment grounding conductor (sized the same as the supply conductors) in the same conduit as the supply conductors from the main or source power panel. Terminate the equipment grounding conductor on the ground bus in the main or source panel and on the isolated ground bus in the Non-Dedicated Power Panel.
- Do not select the Power Panel supplying heavy equipment within the facility as the Non-Dedicated Power Panel supplying the MICROS equipment.
- Dedicate all MICROS AC Power Circuits for MICROS equipment. Do not use these circuits to supply any equipment other than MICROS equipment.
- Install all MICROS AC Power Circuits in a dedicated conduit system. This dedicated conduit system cannot contain circuits other than MICROS circuits. Ensure the conduit used for the MICROS AC Power Circuits is ferrous metallic. Flexible, rigid, or greenfield-metallic conduit is acceptable. **Aluminum conduit is not acceptable.**
- For each dedicated MICROS AC Power circuit, include a full size (same as supply conductors) insulated equipment grounding conductor installed within the same dedicated conduit system as the supply conductors. Terminate this ground conductor at the isolated

ground bus in the Non-Dedicated Power Panel and on the grounding terminal of each Isolated Ground AC Power Receptacle.

- Ensure all AC Power Receptacles are the isolating ground type. Install according to the specifications in the [AC Power Receptacles Grounding](#) section.
- When choosing a base, mid-level, or premium Power Conditioning system, an upgrade to the next level is required if problems occur (e.g. power problems generated by the power company or other equipment in the building).

Power Conditioned AC Power System

This method is an acceptable alternative when the Preferred or Relaxed/ Power Conditioned AC Power System is cost prohibitive and/or would require major structural changes. **However, the Preferred AC Power System is recommended by MICROS.**

The Power Conditioned AC Power System is described as follows:

- MICROS-approved AC Power Conditioners are required at **all** MICROS equipment locations.
- MICROS-approved Uninterruptable Power Conditioners (UPC) are required at **each** server.
- Whenever possible, all MICROS equipment should be installed on the same sub panel. However, MICROS equipment can be supplied by different non-dedicated AC power sub panels, but the sub panels should be supplied by the same main or source panel. If multiple main or source panels are utilized, ground potential problems could arise and severely degrade the performance of the system, even if AC power conditioners are used. Line Drivers or Optical Isolation Devices may be required on selected data transmission cable runs to eliminate the effects of ground potential problems.
- Whenever possible, any Power Panel supplying heavy equipment within the facility should not be selected as the power panel supplying MICROS AC Power Circuits. Equipment problems resulting from utilizing a Power Panel supplying heavy equipment will be reviewed on an individual basis.
- When choosing a base, mid-level, or premium Power Conditioning system, an upgrade to the next level may be required if problems arise. This could be due to power problems generated by the power company or other equipment in the building.

AC Power Consumption and Volt-Amp Ratings for MICROS Equipment

The following information is provided to assist in calculating the UPS and power conditioner size requirements. The ratings for MICROS workstations and peripheral equipment are close to actual. When using the actual ratings, add 20% to the total to account for variations in your systems power consumption.

The Ampere and Volt-Ampere ratings listed below assume a 120Volt AC ~10%, single phase, 60 Hz ~3% input.

Table 25-2 AC Power Consumption of MICROS Hardware Devices

Device	Amp (A)	VA (VA)	Backlight ON (W)/(A)/(VA)	Backlight Off (W)/(A)/(VA)
MICROS Workstations				

Table 25-2 (Cont.) AC Power Consumption of MICROS Hardware Devices

Device	Amp (A)	VA (VA)	Backlight ON (W)/(A)/(VA)	Backlight Off (W)/(A)/(VA)
Edge Controller 250	0.16	17	10/0.16/17	NA
Workstation 655	0.15	18	11.9/0.15/18	6.9/0.10/12
Workstation 625	0.15	18	11.9/0.15/18	6.5/0.09/11
Express Station 410	0.30	36	24.7/0.30/36	5.9/0.08/10
Express Station 400	0.23	27	17.3/0.23/27	3.9/0.06/7
Workstation 320	0.11	13	7.3/0.11/13	3.5/0.06/7
Workstation 310	0.09	11	6.1/0.09/11	3.5/0.06/7
Workstation 610	0.13	16	9/0.13/16	5.6/0.08/10
Workstation 5A	0.36	44	26/0.36/44	15/0.21/25
Workstation 5A w/ Protégé	0.44	52	31/0.44/52	N/A
Workstation 5	0.30	35	23/0.30/35	13/0.20/25
Workstation 4/4 LX	0.22	26	22/0.22/26	15/0.15/18
Keyboard Workstation 4	0.22	26	N/A	N/A
Keyboard Workstation 270 /w No Battery	0.11	13	N/A	N/A
Keyboard Workstation 270 /w Battery Charging.	0.50	61	N/A	N/A
Keyboard Workstation 270 /w Battery Fully Charged.	0.11	13	N/A	N/A
PC Workstation 2010	0.47	55	38/0.39/48	28/0.3/34
PC Workstation 2010 /w TM-T88	0.53	94	N/A	N/A
PC Workstation 2015	0.55	67	45/0.55/67	18/0.25/30
PC Workstation 2015 with Protégé	0.61	77	49/0.61/77	N/A
MICROS Tablet Base Station with optional Battery, Printer, Scanner	0.31	36	N/A	N/A
MICROS Tablet Multi-Unit Charger (Charging Eight Tablets)	1.2A (max)	144	N/A	N/A
Order Confirmation Controller OCC Base Unit	0.17	20	N/A	N/A
OCC Pedestal - Normal (Daytime, Bright Sunlight)	0.54	65	N/A	N/A

Table 25-2 (Cont.) AC Power Consumption of MICROS Hardware Devices

Device	Amp (A)	VA (VA)	Backlight ON (W)/(A)/(VA)	Backlight Off (W)/(A)/(VA)
OCC Pedestal - Winter (Cold Environment - Heater On)	1.36	164	N/A	N/A
OCC Pedestal - Summer (Warm/Hot Environment - Fans On)	0.99	119	N/A	N/A
Order Confirmation Controller				
OCC Base Unit	0.17	20	N/A	N/A
OCC Pedestal - Normal (Daytime, Bright Sunlight)	0.54	65	N/A	N/A
OCC Pedestal - Winter (Cold Environment - Heater On)	1.36	164	N/A	N/A
OCC Pedestal - Summer (Warm/Hot Environment - Fans On)	0.99	119	N/A	N/A
Printers				
Epson TM-T88I,II,III, IV, V	0.25	30	N/A	N/A
Epson U200 Dot Matrix Printer	0.10	12	N/A	N/A
Epson TM-U230	0.35	42	N/A	N/A
Epson TM-U220	0.25	30	N/A	N/A
Epson U950 Combination Printer	0.25	30	N/A	N/A
RDC and LCD Monitors				
Restaurant Display Controller (RDC)	0.10	12	N/A	N/A
e7 Back Office Controller or Digital Menu and Marketing Board Controller.	0.48	57	N/A	N/A
Typical 17" LCD Monitor	0.30	34	N/A	N/A
Typical 46" LCD Monitor	1.71	196	N/A	N/A

Recommended AC Power Conditioning and UPS Equipment

This section is an overview of the Uninterruptable Power Supply (UPS) and power conditioning equipment available for the chosen AC Power System outlined in the [AC Power Requirements](#) section. Failure to comply by the Customer may result in the voiding of any applicable Oracle MICROS hardware warranty and/or jeopardize future coverage under a maintenance agreement.

UPS Product Requirements

Oracle Hospitality POS Systems require the use of an Oracle MICROS-approved UPS on each server. This is required by the nature of the operating system used by some applications. During a power failure, the server becomes vulnerable to significant file and or directory damage. To protect against this occurrence, the use of back-up power is required so an orderly shutdown of the operating system can take place.

PowerVar Single Phase UPS Desktop Models

PowerVar offers the Grounding Technology Solutions (GTS) Series power protection products. The GTS Series is an isolated true sine-wave UPS System and includes a surge diverter, noise filter, and low impedance isolation transformer to guarantee fully conditioned isolated power whether operating on the utility or battery. GTS also prevents the occurrence of ground loops and makes dedicated-isolated electrical circuits obsolete. Some additional features include:

- Product sizes ranging from 250 VA to 800 VA.
- Built-in grounding technology to prevent ground loops.
- Low impedance isolation transformer and line interactive operation.
- Let-through voltage of less than 10V normal mode and less than 0.5 volts neutral-to-ground when tested to ANSI/IEEE C62.41.



The table below shows the available Desktop UPS models with the VA rating, output current, Oracle MICROS part number (PN), and number of outlets for equipment.

Table 26-1 Recommended PowerVar Single Phase Desktop UPS Models

Feature	ABCEG251-11	ABCEG401-11	ABCEG601-11	ABCEG800-11
MICROS Part Number	700247-092-PT	700247-093-PT	700247-094-PT	700247-095-PT
Power Rating VA/Watts	250/200	400/320	600/480	800/560
Input-Output Voltage (VAC)	120-120	120-120	120-120	120-120
Output Current VA/Watts	2.0/1.6A	3.3/2.6A	5.0/4.0A	6.7/4.7A
Frequency(Hz)	60	60	60	60
BTU (/Hr.)	120	177	184	200
Outlets	4	4	8	6
Size (in.) (HxWxD)	6.60 x 5.00 x 13.39	6.60 x 5.50 x 15.10	8.02 x 5.76 x 15.48	8.0 x 5.8 x 17.5
Shipping Weight (lbs.)	23	28	33	47

ONEAC Rack Mount UPS

Figure 26-1 Recommended ONEAC Rack Mount UPS Models



The table below shows the available Rack Mount UPS models with the capacity, load current, Oracle MICROS part number (PN), and number of outlets for equipment.

Table 26-2 Recommended ONEAC Rack Mount UPS Models

Feature	ON1000XAU-SN	ON2000XAU-SN
MICROS Part Number	700247-047-PT	700247-065-PT
Capacity (VA/Watts)	1000/ 700	1920/1345
Input-Output Voltage (VAC)	120-120	120-120
Load Current (Amps)	8.30	16.00
Frequency (Hz)	60	60
Outlets	8	8
Size (in.) (HxWxD)	3.5 x 17.3 x 19.5	7.0 x 17.3 x 19.5
Shipping Weight (lbs.)	65	114

Standard Power Conditioners

The standard Power Conditioner features a low-impedance isolation transformer to protect the equipment from common-mode voltage, which can cause everything from equipment lock-ups to data losses. These models also feature surge suppression and power line filters to eliminate

noise, spikes, and transients before they have a chance to damage equipment. Some additional features include:

- All North American models have UL and cUL listings. International Models are safety agency listed and carry the CE mark.
- Let-through voltage is <10 Volts normal mode and < .5 volts neutral to ground when tested to ANSI/IEEE C62.41.
- Red flashing LED warns if the AC outlet is missing its input safety ground.

Figure 26-2 Approved Wall Mount PowerVar Standard Power Conditioners

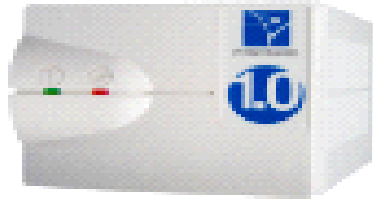

The table below shows the approved power conditioners with the VA rating, output current, Oracle MICROS part number (PN), and number of outlets for equipment.

Table 26-3 Approved Wall Mount PowerVar Standard Power Conditioners

Feature	ABC065	ABC100-11W	ABC150-11W	ABC302-11W
MICROS Part Number	700247-074-PT	700247-076-PT	700247-078-PT	700247-079-PT
VA Rating	78	120	180	360
Input-Output Voltage (VAC)	120-120	120-120	120-120	120-120
Output Current (Amps)	0.65	1.0	1.5	3.0
Frequency(Hz)	60	60	60	60
BTU (/Hr.)	27	41	61	123
Outlets	2	2	2	4
Size (in.) (HxWxD)	3.61 x 4.25 x 6.74	3.61 x 4.25 x 6.74	3.61 x 4.25 x 6.74	4.23 x 4.97 x 7.58
Shipping Weight (lbs.)	5	6	6	11

POWERVAR Ground Guard Line Conditioners

PowerVar Ground Guard power conditioners provide benefits beyond those of traditional power conditioning products. Filter elements in the safety ground circuit prevent the formation of ground loops, which are common in networked applications.

The ground conditioning feature combined with a high energy surge suppressor and a power line filter eliminates the need for both dedicated electrical circuits and isolated ground wiring. Ground Guard carries several U.S. and international patents. Some additional features include:

- Patented Ground Guard conditioning circuitry eliminates ground loops.

- Red LED flashes if AC outlet is missing its input safety ground.
- Let-through voltage is <10 volts normal mode and <.5 volts neutral to ground when tested to ANSI/IEEE C62.41.

Figure 26-3 Approved PowerVar Ground Guard Power Conditioning



The table below shows the approved power conditioners with the VA rating, output current, Oracle MICROS part number (PN), and number of outlets for equipment.

Table 26-4 Approved PowerVar Ground Guard Power Conditioners

Feature	ABCG065	ABCG100-11W	ABCG152-11W	ABCG302-11W
MICROS Part Number	700247-075-PT	700247-080-PT	700247-081-PT	700247-083-PT
VA Rating	78	120	180	360
Input-Output Voltage (VAC)	120-120	120-120	120-120	120-120
Output Current (Amps)	0.65	1.0	1.5	3.0
Frequency(Hz)	60	60	60	60
BTU (/Hr.)	41	41	62	123
Outlets	2	2	4	4
Size (in.) (HxWxD)	4.23 x 4.97 x 7.58	4.23 x 4.97 x 7.58	4.23 x 4.97 x 7.58	4.23 x 4.97 x 7.58
Shipping Weight (lbs.)	5	7	8	11

Ethernet Line Protectors

Ethernet line protectors (PN 700247-211-PT) are recommended for surface or rack mounted chassis with 5, 10, or 16 slots for RM-ELP100 Ethernet Protector modules.

PowerVar Single Phase Desktop UPS - Estimated Run Times

The following tables show estimated run times based on the load in percent of the four approved single phase desktop UPS systems.

The amount of back-up time available is directly related to the VA rating of the UPS utilized. The closer you get to the rated capacity of the UPS, the less back-up time you will have. In addition, make sure to consider battery age.

The runtimes shown in the tables are estimates from PowerVar using new, fully charged batteries at an ambient temperature of 25°C. Depending on the operating environment, UPS batteries lose between 20% and 40% of their capacity after three years. A typical shutdown

takes several minutes to perform; therefore, give careful consideration to UPS capacity vs. battery life.

Table 26-5 Estimated Load Times of ABCEG251-11 (Part Number 700247-092-PT)

Load Item	10% Load Time	20% Load Time	30% Load Time	40% Load Time	50% Load Time	60% Load Time	70% Load Time	80% Load Time	90% Load Time	100% Load Time
Volts	121	122	122	122	122	122	122	122	122	121
Amps	0.15	0.30	0.44	0.59	0.74	0.87	1.01	1.17	1.31	1.46
Watts	17.5	3	52.5	70	87.5	105	122	140	158	175
Run Time (Mins)	140	48	56	43	23	19	16	13	12	10

Table 26-6 Estimated Load Times of ABCEG401-11 (Part Number 700247-093-PT)

Load Item	10% Load Time	20% Load Time	30% Load Time	40% Load Time	50% Load Time	60% Load Time	70% Load Time	80% Load Time	90% Load Time	100% Load Time
Volts	122	121	120	121	122	121	121	121	120	119
Amps	0.24	0.46	0.70	0.92	1.15	1.40	1.63	1.88	2.10	2.36
Watts	28	5	84	112	140	168	196	224	252	280
Run Time (Mins)	65	30	28	19	15	13	11	8	7	6

Table 26-7 Estimated Load Times of ABCEG601-11 (Part Number 700247-094-PT)

Load Item	10% Load Time	20% Load Time	30% Load Time	40% Load Time	50% Load Time	60% Load Time	70% Load Time	80% Load Time	90% Load Time	100% Load Time
Volts	122	122	121	121	121	122	121	121	116	114
Amps	0.35	0.69	1.04	1.39	1.74	2.07	2.44	2.78	3.26	3.66
Watts	4	84	126	168	210	252	294	336	378	420
Run Time (Mins)	90	55	39	30	24	18	14	11	19	7

Table 26-8 Estimated Load Times of ABCEG800-11 (Part Number 700247-095-PT)

Load Item	10% Load Time	20% Load Time	30% Load Time	40% Load Time	50% Load Time	60% Load Time	70% Load Time	80% Load Time	90% Load Time	100% Load Time
Volts	118	119	118	118	117	119	118	118	118	120
Amps	0.44	0.87	1.32	1.76	2.21	2.63	3.08	3.52	3.94	4.36
Watts	5	110	165	224	280	335	395	450	500	560

Table 26-8 (Cont.) Estimated Load Times of ABCEG800-11 (Part Number 700247-095-PT)

Load Item	10% Load Time	20% Load Time	30% Load Time	40% Load Time	50% Load Time	60% Load Time	70% Load Time	80% Load Time	90% Load Time	100% Load Time
Run Time (Mins)	77	46	32	23	17	14	11	10	8	6

27

Cable Requirements

The following sections describe the Ethernet and IDN cable requirements for Oracle MICROS workstations, printers, and remote display systems:

- [Planning the Network](#) introduces the concept of a structured cabling system and provides MICROS recommendations and requirements for Ethernet and IDN cabling.
- [Installing the Ethernet Network](#) describes how to run the cables and terminate them at the wall plate.
- [Installing an Integrated Device Network \(IDN\)](#) describes the cabling options available for driving MICROS IDN printers, including the use of a structured cable system.
- [Installing a Kitchen Display System](#) describes the site requirements for implementing a KDS and includes the MICROS wired (MBB) and wireless (MWBB) bumpbars.
- [Installing the e7 Kitchen Video Monitor \(KVM\)](#) describes the cable requirements for implementing a serial interface to the host workstation.
- [Installing the Order Confirmation System](#) describes the requirements for installing the curb-side Pedestal including the concrete slab and conduit egress.
- [Recommended Cables for a MICROS RS422 ION Network](#) lists MICROS-approved IDN cabling.

28

Wireless Infrastructure

To service the MICROS Tablets, mobile Workstations, and desktop Workstations with an optional Wi-Fi card, one or more wireless access points may be required. The placement of Wireless Access Points at a given property are determined through a site survey.

The *Wireless Networking Best Practices Guide* provides guidance for the setup of wireless networks.

Network Requirements and Planning

Oracle MICROS recommends that a qualified network professional plan, install, and certify the network.

For reliability and ease of troubleshooting, all current Oracle MICROS products use 100/1000 BaseT networking topology based on twisted pair cabling. The benefits of this include:

- Reduced Cable Costs

The installation of cable costs far more than the cable itself. The widely touted appeal of 10/100/1000 BaseT is that it gives one the option of using existing telephone wiring, thus saving installation costs. However, most sites do not have enough existing high-quality twisted pair cable available to support a network installation, so more cable has to be pulled anyway. The use of existing telephone wiring requires Oracle MICROS approval.

- Troubleshoot Management, Fault Isolation, and Security

With the Ethernet star topology, problems are easy to troubleshoot. A single workstation or printer is connected to a single port on the hub, switch or router, allowing the behavior of each connection to be individually monitored. LED indicators on each port provide immediate feedback on the link integrity and speed. A failure is quickly isolated, and the remaining Ethernet devices continue to operate while the problem is being addressed. Adding or moving devices is as simple as installing a wall plate or plugging into a pre-wired connection at the switch or patch panel. Even in small or low-cost installations, the single point of concentration, point-to-point connectivity, and link status LEDs make diagnosing a problem on a 100/1000 BaseT network much easier than checking an entire length of coax cable for a break.

Structured Cabling Systems

When planning your network, Oracle MICROS recommends the Commercial Building Telecommunications Cabling Standard TIA/EIA-568-C.

TIA/EIA-568-C defines standards for the implementation of structured cabling systems for commercial buildings and between buildings in a campus environment. It is composed of four sections.

The primary standard, TIA/EIA-568-C.1 defines the general requirements such as cable types, distances, cable termination, and certification methods. -568-C.2 focuses on twisted-pair cabling systems, -568-C.3 covers fiber optic cable systems, and -568-C.4, addresses coaxial cabling components.

The complete specification and related documents are published by Global Engineering Documents (www.global.ihs.com).

If a customer requests a structured cabling system other than ANSI/TIA/ EIA-568-C, a disclaimer should be drawn up absolving Oracle MICROS of responsibility for data cable related problems.

Elements of a Structured Cabling SystemA structured cabling system divides premise wiring into five basic elements. Four of these elements are shown in Figure 39. Each component, including the fifth, Network Administration, is discussed in the following paragraphs.

- Work Area

The work area encompasses all components between the faceplate and Ethernet based device. This includes the patch cable between the faceplate and Ethernet device. Each work area is served by a telecommunications closet or wiring closet on the same floor.

- Horizontal Cabling

This section consists of the cabling between the work area and the telecommunications closet. This includes the faceplates in the work area, the cable run to the faceplates or patch panel in the wiring closet.

Horizontal cabling can use UTP or STP cables and connection hardware. The use of a 110 connect system to terminate horizontal cables at the wall plate and patch panel is recommended.

The maximum distance for any horizontal cable run is 90 meters (295 ft.) independent of the cable type. 90 meters allows an additional 10 meters (33 ft.) for patch cables in the work area and wiring closet.

- Computer Room or Telecommunications Closet

All buildings should include at least one telecommunications or wiring closet that contains the hardware required to connect the horizontal cable runs from each work area to the patch panels and hubs. Patch panels are key elements of any structured cable system. Moves and changes are performed by moving a modular patch cord on the patch panel. Other devices on the network are unaffected by a change to an individual connection at the patch panel.

Use appropriate cable routing and dressing fixtures in the wiring closet to eliminate stress caused by tension and to effectively organize cables.

- Backbone Cabling

Backbone cabling is the structured cabling element that provides interconnections between multiple wiring closets. However, in a small system that is served by an 8, 12, or 16 port switch/router, a backbone cable is not required unless the POS LAN becomes part of an existing on-site network or requires internet access.

Fiber is the recommended solution when distances between wiring closets is greater than 100 meters.

- Network Administration

While not shown in the illustration, it is as important as any other element of the system. Network Administration encompasses system documentation, security, and backing up user data.

- System Documentation

Document even the smallest systems to allow for additions, troubleshooting, and equipment moves. Documentation includes producing a physical plan of the system that maps out the location of each device and the wiring between each.

Implement password protection schemes on each workstation (and server, if applicable) to prevent unauthorized use of the application software or to prevent unauthorized access to critical data files. Implement a procedure where unique user passwords are created and stored in a central, secure location.

Deploy procedures to change passwords at regular intervals and to remove the passwords for users who no longer have access to the network.

- Backups

Roofs leak, pipes burst, hard disks fail, lightning strikes, and sometimes it even strikes twice. Any number of sources can cause the loss or corruptions of data and application files. Backing up system data and totals on a regular basis and storing them in a safe and

secure place is a critical part of Network Administration, and speeds up the recovery process in the event something does go wrong.

Develop a procedure that defines when server backups occur, how often they are performed, and how often backup tapes are rotated and stored. Backup tapes stored on-site are useless if the building is flooded or burns down. Keeping a second set of backup tapes secure and offsite is a worthwhile precaution.

Elements of a Structured Cabling System

A structured cabling system divides premise wiring into seven basic elements. Four of these elements are shown in [Structured Cabling Examples](#) section. Each component, including the fifth, Network Administration, is discussed below.

- Work Area

The work area encompasses all components between the faceplate and Ethernet based device. This includes the patch cable between the faceplate and Ethernet device. Each work area is served by a telecommunications closet or wiring closet on the same floor.

- Horizontal Cabling

This section consists of the cabling between the work area and the telecommunications closet. This includes the faceplates in the work area, the cable run to the faceplates or patch panel in the wiring closet.

Horizontal cabling can use UTP or STP cables and connection hardware. The use of a 110 connect system to terminate horizontal cables at the wall plate and patch panel is recommended.

The maximum distance for any horizontal cable run is 90 meters (295 ft.) independent of the cable type. 90 meters allows an additional 10 meters (33 ft.) for patch cables in the work area and wiring closet.

- Computer Room or Telecommunications Closet

All buildings should include at least one telecommunications or wiring closet that contains the hardware required to connect the horizontal cable runs from each work area to the patch panels and hubs. Patch panels are key elements of any structured cable system. Moves and changes are performed by moving a modular patch cord on the patch panel. Other devices on the network are unaffected by a change to an individual connection at the patch panel.

Use appropriate cable routing and dressing fixtures in the wiring closet to eliminate stress caused by tension and to effectively organize cables.

- Backbone Cabling

Backbone cabling is the structured cabling element that provides interconnections between multiple wiring closets. However, in a small system that is served by an 8, 12, or 16 port switch/router, a backbone cable is not required unless the POS LAN becomes part of an existing on-site network or requires internet access.

Fiber is the recommended solution when distances between wiring closets is greater than 100 meters.

- Network Administration

While not shown in the illustration, it is as important as any other element of the system. Network Administration encompasses system documentation, security, and backing up user data.

- System Documentation

Document even the smallest systems to allow for additions, troubleshooting, and equipment moves. Documentation includes producing a physical plan of the system that maps out the location of each device and the wiring between each.

Implement password protection schemes on each workstation (and server, if applicable) to prevent unauthorized use of the application software or to prevent unauthorized access to critical data files. Implement a procedure where unique user passwords are created and stored in a central, secure location.

Deploy procedures to change passwords at regular intervals and to remove the passwords for users who no longer have access to the network.

- Backups

Roofs leak, pipes burst, hard disks fail, lightning strikes, and sometimes it even strikes twice. Any number of sources can cause the loss or corruptions of data and application files. Backing up system data and totals on a regular basis and storing them in a safe and secure place is a critical part of Network Administration, and speeds up the recovery process in the event something does go wrong.

Develop a procedure that defines when server backups occur, how often they are performed, and how often backup tapes are rotated and stored. Backup tapes stored on-site are useless if the building is flooded or burns down. Keeping a second set of backup tapes secure and offsite is a worthwhile precaution.

Structured Cabling Examples

The two figures below show the MICROS workstations and peripherals integrated into a structured cabling system, including an example of a Symphony single workstation and printer installation.

- Kitchen Display System

The KDS Controller requires a Category 6 or better faceplate and patch cable. If the 7 KVM Controller uses Ethernet, a Category 6 or better faceplate and patch cable are required. In addition to the KDS or e7 KVM, connect all LCD Monitors to dedicated, isolated ground AC outlets installed in accordance with the procedures outlined in the [AC Power Requirements](#) section.

- Wireless Access Points

Install Wireless Access Point(s) after a site survey is performed by a qualified wireless professional.

Connect Wireless Access Point(s) to a dedicated, isolated ground AC outlet installed in accordance with the procedures outlined in the [AC Power Requirements](#) section.

- MICROS Workstations

Each MICROS Workstation location requires a Category 6 faceplate and patch cable. Each MICROS workstation requires a dedicated, isolated ground AC outlet installed in accordance with the procedures outlined in the [AC Power Requirements](#) section.

- IP Printers

The IP Printer is any supported Epson model equipped with Ethernet Module. Each printer requires one Ethernet channel as well as a dedicated, isolated ground AC outlet installed in accordance with the procedures outlined in the [AC Power Requirements](#) section.

- Order Confirmation Controller

The Order Confirmation Controller requires a Category 6 faceplate and patch cable to connect to the POS application. It also requires a second Category 5e or better faceplate

and patch cable as well as a Category 5e or better cable run to the Remote Display Unit housed in the pedestal.

The [Installing the Order Confirmation System](#) section provides installation instructions for the Order Confirmation System.

- Digital Menu and Marketing Board Controller

Each Digital Menu Board Controller in a system requires a Category 6 or better Ethernet faceplate and patch cable. Each Digital Menu Board Controller(s) and each LCD monitor requires a dedicated, isolated ground AC outlet installed in accordance with the procedures outlined in the [AC Power Requirements](#) section.

- e7 KVM Controller

If the KVM Controller Ethernet port is used, place the Category 6 or better Face Plate and Patch Cable near the unit and host workstation. The [Cable Requirements](#) section contains more information.

The KVM Controller, Monitors, and optional printer require the Preferred AC Power System detailed in the [AC Power Requirements](#) section.

- IP Printers

The IP Printer is any supported Epson model equipped with Ethernet Module. Each printer requires one Ethernet channel as well as a dedicated, isolated ground AC outlet installed in accordance with the procedures outlined in the [AC Power Requirements](#) section.

- Order Confirmation Controller

The Order Confirmation Controller requires a Category 6 faceplate and patch cable to connect to the POS application. It also requires a second Category 5e or better faceplate and patch cable as well as a Category 5e or better cable run to the Remote Display Unit housed in the pedestal.

The [Installing the Order Confirmation System](#) section provides installation instructions for the Order Confirmation System.

- Digital Menu and Marketing Board Controller

Each Digital Menu Board Controller in a system requires a Category 6 or better Ethernet faceplate and patch cable. Each Digital Menu Board Controller(s) and each LCD monitor requires a dedicated, isolated ground AC outlet installed in accordance with the procedures outlined in the [AC Power Requirements](#) section.

- e7 KVM Controller

If the KVM Controller Ethernet port is used, place the Category 6 or better Face Plate and Patch Cable near the unit and host workstation. See the [Cable Requirements](#) section for details.

The KVM Controller, Monitors, and optional printer require the Preferred AC Power System detailed in the [AC Power Requirements](#) section.

Figure 29-1 Example of MICROS Equipment in a Structured Cabling System

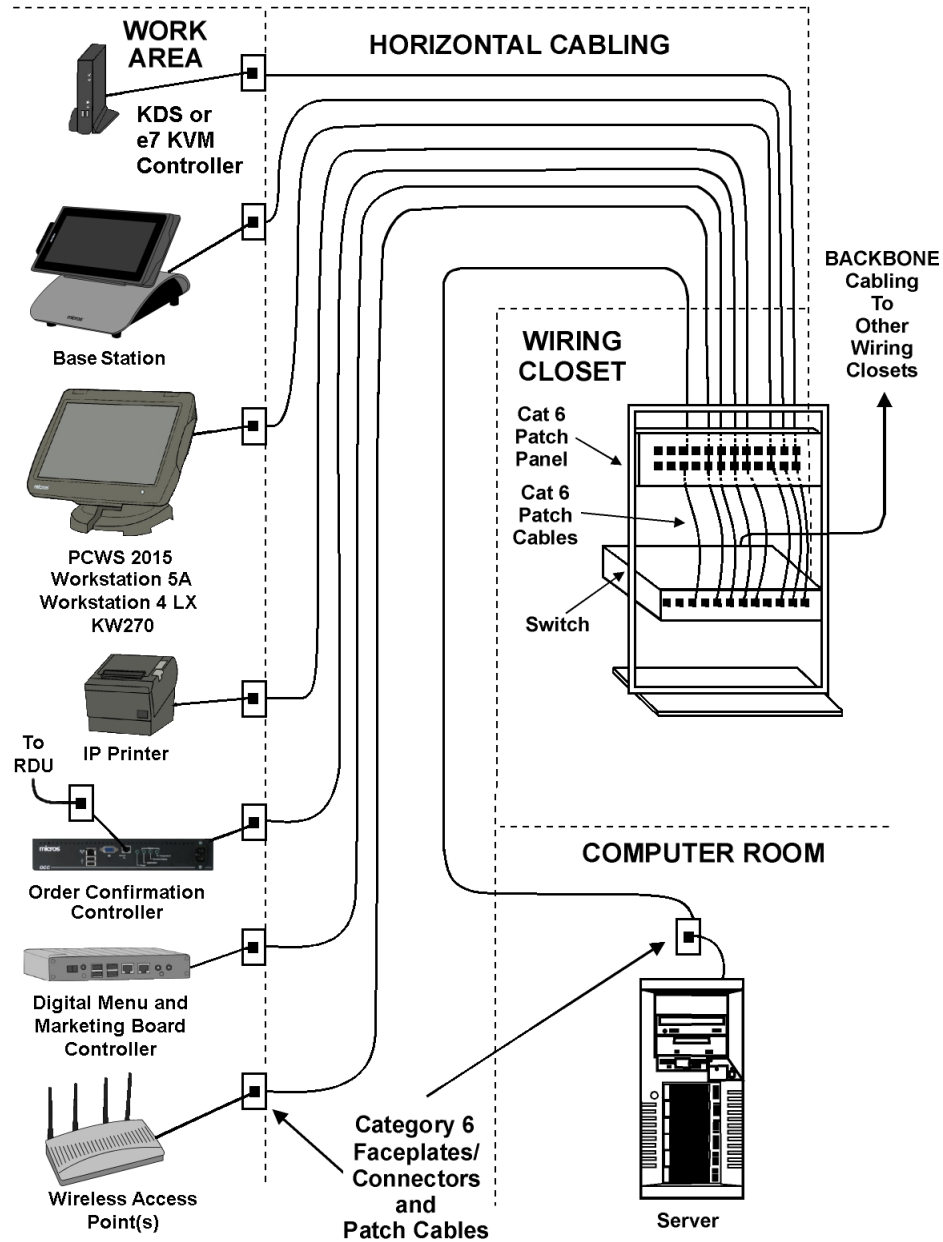
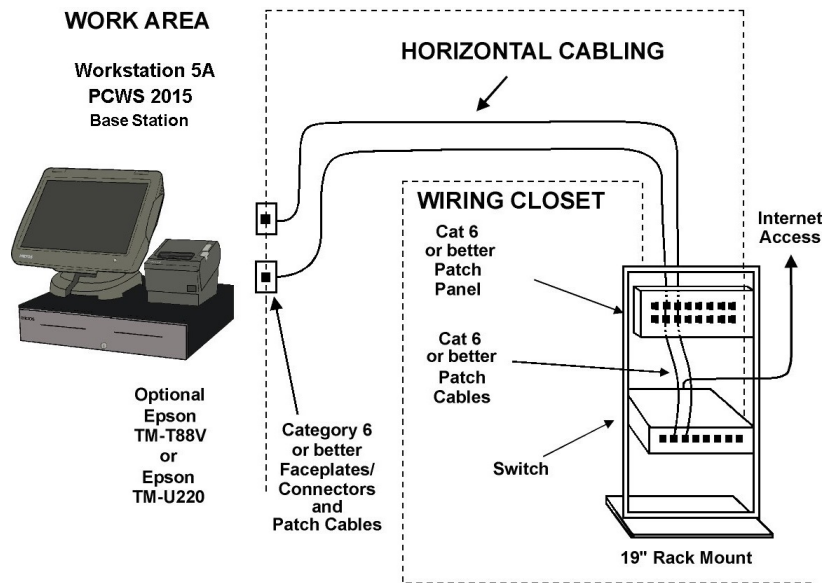

Figure 29-2 Example of a Single Workstation and Printer Installation for Symphony



Cable Types

The following data cable types are found in a typical installation.

- Ethernet Cabling

In the electrically active environments that MICROS hardware typically operates, we strongly recommend shielded Ethernet cabling and connection hardware.

In electrically quiet environments, a certified UTP Category 6 or better cabling system and connection hardware is acceptable and does not void the hardware warranty. However, issues related to non-shielded cable may be subject to out-of-scope billing charges.

- IDN Cabling

For IDN cabling, shielded cables or non-shielded cables installed in a separate grounded ferrous metal conduit are required.

Cable Categories

Ethernet cabling is placed into categories that define the quality of both the cable as well as related connection hardware such as faceplates, modular connectors and patch cables.

Several categories of UTP and related connection hardware are defined for a structured cabling system. Several cable suppliers now offer the STP equivalent of Category 6 cables and connection hardware. Each category is briefly defined below.

- Category 5e

The Category 5e standard was formally defined in 2001.

Category 5e represents an incremental improvement over Category 5 with tighter specifications designed to support full-duplex Fast Ethernet and Gigabit Ethernet. Most current MICROS terminals support Gigabit Ethernet.

Category 5e cable performance characteristics and certification methods are defined in ANSI/TIA/EIA-568-B.2-2001.

- Category 6

Category 6, ratified in June 2002 (ANSI/TIA/EIA-568-B.2-1), provides higher performance than Category 5e with more stringent specifications for crosstalk and system noise in addition to supporting a bandwidth up to 250MHz. Category 6 cable is standardized for Gigabit Ethernet, a port included on all current MICROS workstations.

Category 6a cable, or Augmented Category 6, was defined in February 2009 in ANSI/TIA-568-C.1 and is characterized to operate at 500 MHz with improved alien crosstalk characteristics.

Ensure the installation and termination of Category 6 or 6a cables and connection hardware meet the required specifications.

In sites with a high amount of electromagnetic interference (EMI), shielded cables are required. The shielding reduces the effect of EMI on data carried by the cable. Maintain the shielding from one cable end to another using a drain wire in the same sheath as the twisted pairs.

Mechanical and Electrical Considerations for Cable Installation

- UTP Cable Installed in Metal Conduit

If you want to install UTP cabling in a grounded metal conduit, consider the following:

- Use conduit composed of ferrous metal. Aluminum conduit is unacceptable as it provides little or no protection from EMI.
- Use conduit throughout the system from junction box to junction box to ensure an adequate ground return path.

- PVC Conduit

When cables are buried below the floor level, the use of PVC Conduit is permitted. When using PVC conduit in concrete flooring, the following guidelines apply:

- Locate the PVC conduit at least six inches below the surface of the floor.
- Locate the PVC conduit at least six inches from other nearby conduits.

- Cable Damage

The possibility of mechanical damage to cables is generally apparent at the time of installation. This includes outdoor runs of cable, as sunlight, rain and mechanical flexing due to wind causes the cable to deteriorate. Do not kink or tightly bend the cable; the bend radius should be at least four times the outside cable diameter.

- Lightning

Lightning does not need to directly strike the cabling to cause damage or disruption to the system. Nearby lightning strikes produce strong electromagnetic fields that can induce voltages on the data transmission cables causing disruptions or damage. Use a grounded ferrous metal conduit for installations in geographical areas subject to frequent thunderstorm activity. In cases where shielded cables are used, reduce the effects of lightning by placing the cable runs as close to ground level as possible.

- Electrical Motors

Motors of various sizes are found in a typical restaurant or hotel site. Use a grounded ferrous metal conduit when running cabling at distances less than two feet from motors

that are 1/4 horsepower or smaller, or less than six feet from motors larger than 1/4 horsepower.

- Radio Frequency Interference (RFI)

The probability of RFI varies in accordance with many factors, including transmitter power, location, construction materials used in the building, and the physical placement of the power and data transmission cables.

Ethernet Network Installation

The following sections describe the recommended cable lengths and how to terminate the cables at each face plate/wall jack.

Topology

A twisted-pair Ethernet LAN is based on the distributed star or tree wiring topology where the network switch or router is the central element.

Cable Runs

Before cable is pulled, determine the physical location of all devices including the workstations, servers, wireless access points, IP Printers, RDU, and OCC. Specify the equipment location in the floor plan or riser diagram of the property.

Workstations, IP Printers, KDS Controller, and OCC

Ensure all horizontal cable runs from the patch panel/switch/router(s) to individual work area faceplates are at least 3 meters (10 feet) to no more than 90 meters (295 feet). The 3 meter minimum allows collisions to be more easily detected.

Limiting the cable run to 90 meters reserves 10 meters (33 ft.) for patch cables at the patch panel and the device.

Ensure all faceplates, modular connectors, patch panels and patch cords are the same category as the selected cable. In other words, when you pull Category 6 cable, ensure all other components are rated for Category 6 as well. If you are installing shielded cable, all other components including the patch panel must provide a location to terminate the ground wire.

LAN Cable Termination

Several methods are available for terminating the horizontal cable runs. Oracle MICROS recommends the 110 Connect system by AMP or other suppliers. This system uses the reliable 110 style punch-down RJ45 modular jack and are available in both shielded and non-shielded versions.

A second termination method is based on the 8-pin RJ45 modular “keystone” insulation displacement connector, similar to those available for MICROS IDN devices. The cable is attached to this connector by placing all conductors in the appropriate connector cap, and then forcing the connector cap into place.

The figure below shows a “keystone” modular jack on the left and a 110 modular connector on the right.

Figure 30-1 8-Pin Keystone (left) and 110 Connect (right) RJ45 Modular Jack

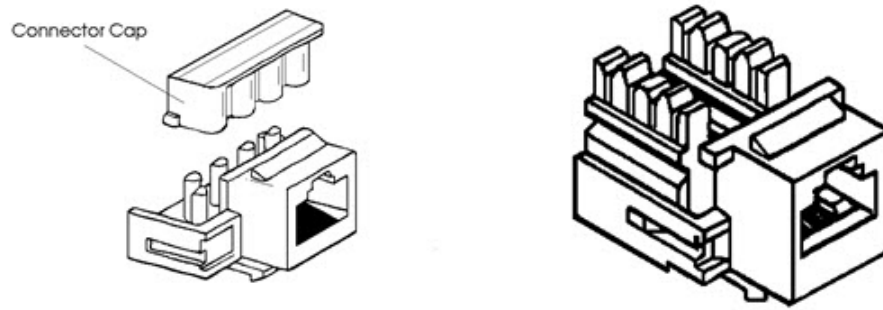

In addition, there are two methods for terminating the cable. The figures below show how to terminate cables at the faceplate connectors using the ANSI/TIA/EIA-568-A or ANSI/TIA/EIA-568-B cabling standard.

ANSI/TIA/EIA-568-B.1-2001 specifies that horizontal cables are terminated using the T568A pin/pair assignments, or optionally terminated with the T568B pin pairs to accommodate certain cabling systems. Mixing T568A terminated horizontal cables with T568B terminated patch cords (or the reverse) is not recommended.

Please note that pins 1-2, 3-6, 4-5, and 7-8 are +/- signal pairs twisted with each other within the cable. You must maintain these signal pairs at each end of the cable as well as the patch cables.

Figure 30-2 Cable Termination

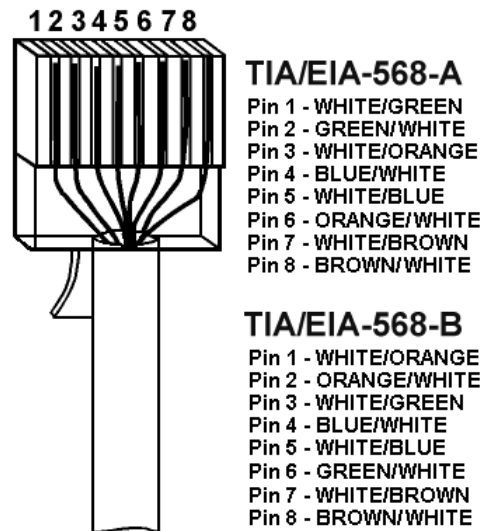
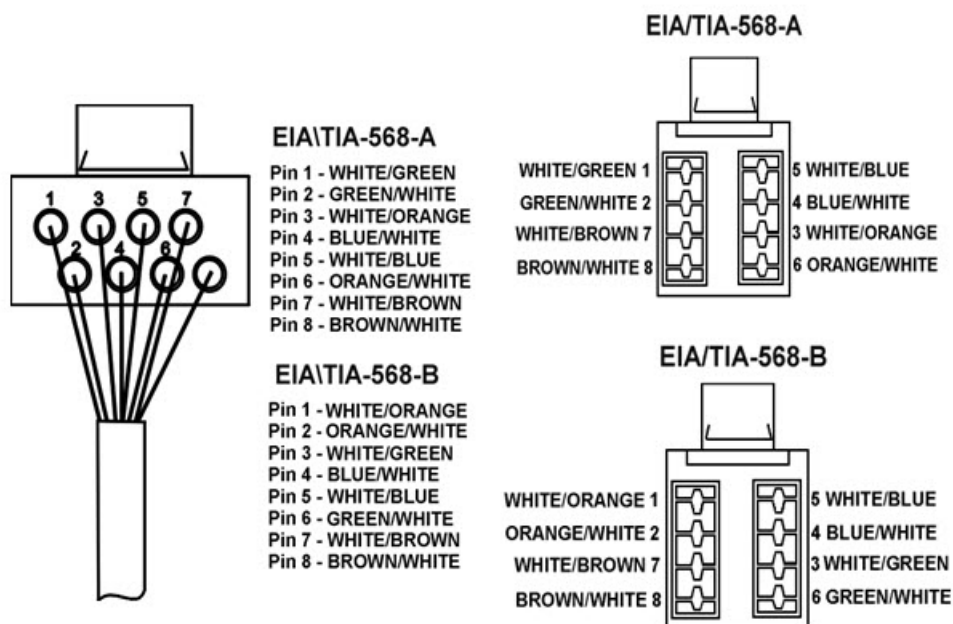

Figure 30-3 Keystone Modular (left) or 110 Connect Modular (right)



Extending Ethernet Beyond the 90 Meter Limit with Fiber Optic Cable

Fiber optic cables have conductors made of glass, rather than metal. A typical fiber cable is composed of a glass core that carries the light signals. The core is encased in cladding that keeps the light contained in the core.

No electrical impulses are carried over a fiber optic cable as in a metal cable. Instead, the electrical impulses are converted to pulses of light that indicate whether a bit is 1 or a 0.

Signals on metal cables and the light in a fiber optic cable travel at approximately the same speed, but light meets less resistance as it travels along the cable. Therefore, light signals go further with less attenuation. Fiber optic links on simple LANs can run without a repeater to distances of more than 3.5 kilometers.

Fiber based cabling systems are more reliable than metallic cabling systems because they are immune to electrical noise generated by support equipment in the building. Despite shielding, grounding, and bypassing, metallic cables can behave like antennas, making them susceptible to RF noise. The greater the length of the cable, the greater the possibility it will be subject to interference from nearby electrical equipment.

In addition, metallic cables are subject to an effect that produces voltage potentials between the cable and electrical ground. This can occur in large buildings or campus environments where equipment is powered from multiple AC power panels that are not operating at the same AC ground potential.

At the very least, the voltage potential can skew the data signals on the cable, causing transient disruptions and or occasional losses of data. If the voltages are great enough, arcing between cable segments and smoked network interface components are possible. Fiber optic cable is immune to these phenomena.

Fiber is recommended for distances greater than 100 meters or as a solution to ground potential issues. A number of cost effective media converters conforming to this standard are available. Many use fiber connectors that are easy to terminate.

The recommend media converter from Transition Networks (as well as other suppliers) uses ST type fiber connectors that are easier to terminate than other types of fiber connectors. In addition, prefabricated fiber cables of various lengths pre-terminated with ST connectors are available.

- Recommended Fiber Based Media Converters

One of the most efficient ways of extending a 100Mbps cable segment beyond the 90 meter limit is with a pair of media converters. These devices allow you to insert a fiber cable between two copper cable segments to extend the total distance between two Ethernet devices.

In a structured cabling system, individual cable runs are limited to 90 meters (100 meters minus 10 meters for patch cables at each end), or 295ft. However, running an Ethernet cable beyond this distance is often a requirement for large sites. In addition, the use of a media converter can also be used to isolate clusters of MICROS equipment if a site is experiencing AC ground potential issues.

Media converters are available that can increase the distance between any two Ethernet devices up to 2000 meters, (6,600ft) using multi-mode fiber, or up to 20000 meters (66,000ft) using single mode fiber without a repeater.

Oracle MICROS recommends Transition Networks copper to fiber media converters. These devices can extend a cable segment up to 2000 meters, more than adequate for most situations. Other features include power, data, and link status indicators.

Integrated Device Network (IDN) Installation

The following sections describe how to install a network of MICROS Integrated Device Network (IDN) printing devices supported by all Oracle MICROS application software.

In most cases, IDN printer(s) are driven by the RS422-A/RS422-B or IDN port of a Workstation.

The following methods are used to connect IDN devices:

- The first method makes use of what we call the 'traditional' MICROS IDN connection hardware, combined with MICROS approved in-wall RS422 cabling.
- The second method utilizes a custom MICROS IDN to Ethernet Patch Cable to build an IDN based on shielded cable and connection hardware. This cabling method is installed and certified by cable contractors in the same manner as Ethernet cabling.

Additionally, Ethernet Printer modules are available (sometimes referred to as 'IP' printers). Printers equipped with Ethernet Modules are connected to the LAN like any other Ethernet Device, requiring a Category 6 or better faceplate and patch cable.

Recommended Cables for a MICROS RS422 ION Network

This sections lists the specifications for the RS422 cabling used for IDN printing devices. For sites not using metal conduit, ensure the cable is shielded appropriately. It is also acceptable to use a shielded Category 6 or better cable.

The following cables are recommended for MICROS RS422 IDN Networks:

- Shielded RS422 Cable (MICROS PN 300319-036-PT)
- Unshielded RS422 Cable (MICROS PN 300319-001-PT)

The following cables are MICROS-approved RS422 IDN equivalents:

- Shielded Cable with PVC Insulation:
 - Belden 9829
 - Olympic 3929
 - Manhattan 3980
 - Carol C0829
- Shielded Cables with Teflon Insulation:
 - Belden 89855
 - Berk Tek 256133
 - Olympic 6173T
- Non-Shielded Cables with PVC Insulation:
 - Belden 8444
 - Olympic 2998
- All CAT6 or better UTP or STP cable that meets the ANSI/EIA/TIA- 568-A/B specifications and has a PVC jacket.

- Non-Shielded Cables with Teflon Insulation
- Belden 89729, 88444
- Olympic 2998T
- All CAT6 or better UTP or STP cable that meets the ANSI/EIA/TIA- 568-A/B specifications and has a Teflon jacket.

Traditional MICROS RS422 Cabling and Connection Hardware

This section introduces the 'traditional' MICROS IDN connection hardware. To review examples using the traditional IDN cabling and connection hardware to drive IDN printers from any MICROS Workstation, refer to the [Lan Cable Termination](#) section.

Wall Plate

This wall plate mounts to a standard 4x4 metal or plastic conduit box with a plaster ring purchased by the installer. Four screws are provided to mount the plate to the box. To install modular connectors, you must first remove a plastic "knock-out," then snap the connector into place.

6-Pin Modular Connector

This six-pin keystone style modular connector terminates the in-wall wiring at each IDN device in the system. Included in the same package is the connector cap. Cable termination is completed by inserting the conductors and the shield or drain wire into the cap and forcing the cap onto the pins of the connector.

Patch Cables

An 8-Pin to 6-Pin IDN Patch Cable is included with each IDN printing device. This cable connects the device to the 6-pin modular connector on the wall plate.

All IDN printer modules include a pair of 6-pin connectors wired in parallel to allow a daisy chain to another printer.

IDN Connectors on MICROS Workstations

All current MICROS workstations include at least one port capable of driving IDN printers.

- The Workstation 6 includes two ports, RS-422 and RS-232, each capable of driving IDN devices.
- The MICROS Tablet E-Series and R-Series Base Station contains one RS232 port recommended for the mini-printer and one switchable RS422/232 port multi-function port for IDN devices.
- The PCWS 2010, 2015, and Workstation 5/5A include an 8-pin port designated as COM4/IDN to drive IDN devices.
- The Workstation 4/4 LX and KW270 include two ports, designated RS422- A and RS422- B, each capable of driving IDN devices.

Cable Runs

IDN cable runs are installed in a multi-drop or daisy chain configuration to each device to form a network. For examples, refer to the [Lan Cable Termination](#) section. An Oracle MICROS approved RS422 cable is started at the wall plate near the workstation and is daisy chained to a wall plate near the first printer and so forth until all printers are connected.

The absolute maximum length of an IDN cable run is 4000 feet using shielded or non-shielded.

Shielded Cable and Connection Hardware for IDN

Oracle MICROS IDN printers can be integrated into a more robust shielded structured cabling system by using a pair of custom MICROS patch cables for examples, refer to the [Lan Cable Termination](#) section. These custom patch cables, a 6-Pin to 8-Pin version and an 8-Pin to 8-Pin version, place the MICROS RS422 transmit/receive pairs on the ANSI/TIA/EIA-568-A compliant transmit/receive pairs.

Components

All versions are based on shielded twisted pair cabling and connection hardware, providing the highest level of immunity from EMI.

The heart of this system is a shielded patch panel and grounding hardware. The MICROS IDN to Ethernet patch cables, shielded faceplates, modular connectors, and patch cables, all of the same cable category, are also required at each printer location. The shielded modular connectors and patch panel connectors differ from their non-shielded counterparts by providing a method of terminating the drain wire.

IDN Connectors

This section describes ports that are used to drive MICROS IDN Printers.

All MICROS Workstation contain at least one 8-pin modular port designated for driving IDN devices.

The figure below is an example of driving a small network of IDN printers from any Workstation with an IDN port using shielded category 6 or better cable and connection hardware.

In this figure, the workstation driving IDN printers is shown at the left of the illustration. One 8-Pin to 6-Pin IDN patch cable is connected between the 8-pin IDN ports on the workstation to one of the 6-pin connectors on the local module.

A Patch cable is then installed between the remaining 6-pin connector on local IDN printer and the faceplate connector to convert the IDN transmit/receive pairs into ANSI/TIA/EIA-568-A compatible transmit/receive pairs.

Install a pair of Cat 6 or better shielded cables between the patch panel and the two connectors on the wall plate near each printer location. The 'dual run' to the faceplate is required to obtain cable certification since a daisy chain configuration is not part of Ethernet topology. Terminate the drain wire of each cable run at the patch panel.

To maintain the IDN daisy chain, install Category 6 or better patch cables at the patch panel. At each remote printer location, install a pair of patch cables to maintain the daisy chain at the printers. The last printer in the chain requires only one patch cable.

Figure 31-1 MICROS Workstation Driving IDN Printers over Shielded Cabling

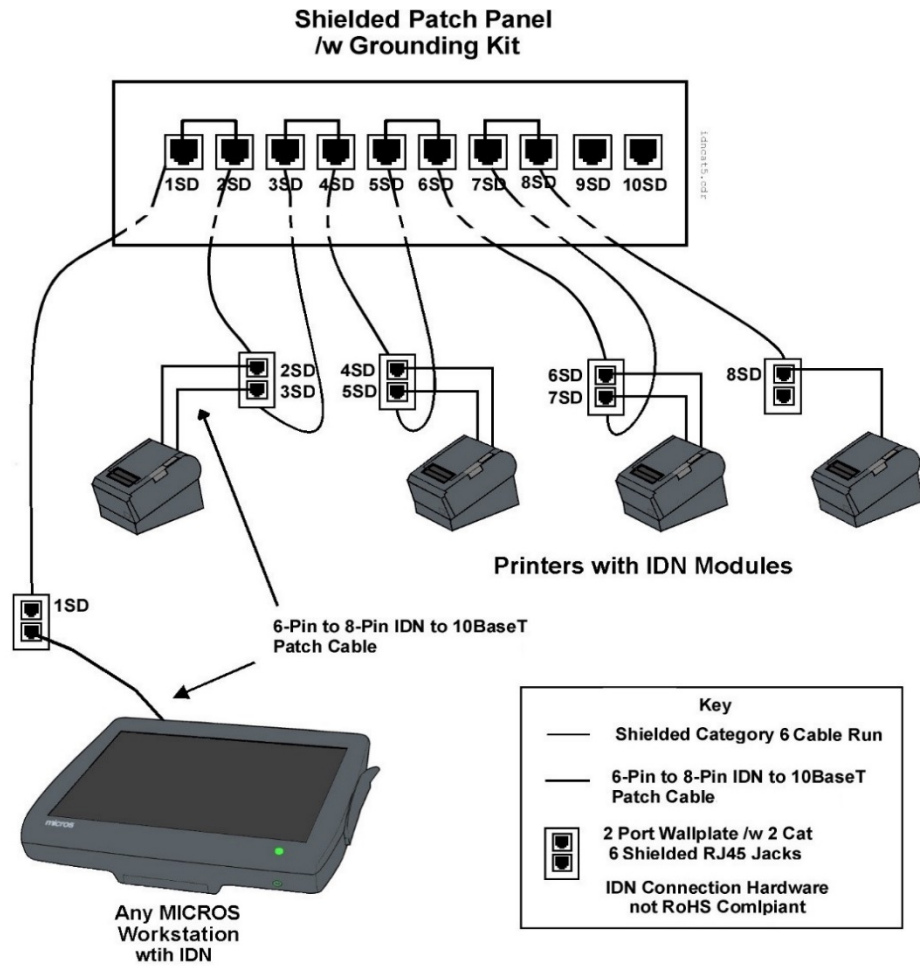

Terminating the IDN Cable

1. Refer to [Lan Cable Termination](#) before terminating the IDN cable at each modular connector.
2. Attach the printer to the wall plate with the 6-pin to 6-pin patch cable supplied with the device.

- PIN 1 - BLACK (WHITE/GREEN)
- PIN 2 - BROWN (GREEN/WHITE)
- PIN 3 - RED (WHITE/ORANGE)
- PIN 4 - ORANGE (ORANGE/WHITE)
- PIN 5 - Not Used
- PIN 6 - Shield or Drain Wire

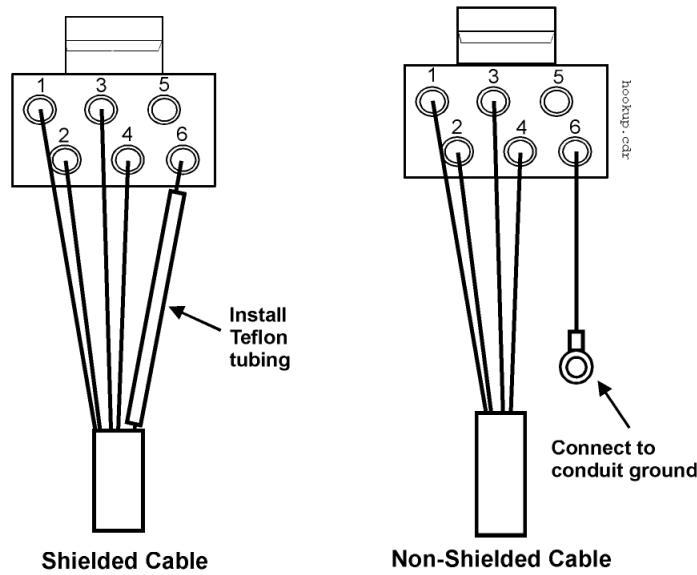

3. Strip the outer insulation off of the cable to expose about 1 inch of the conductors. Do not strip the insulated conductors.
4. Place the color coded conductors and ground wire into the connector cap and press the cap into place. If this is a multi-drop connection, place two conductors of a like color into the connector cap and press the cap into place. Use a small pair of pliers to push the connector cap into place.
5. If shielded cable is used, place the length of Teflon tubing over the drain wire to prevent it from shorting to the other conductors.
6. If non-shielded cable is used, fasten the ring terminal on the ground wire to conduit ground.
7. Repeat at each IDN connector.

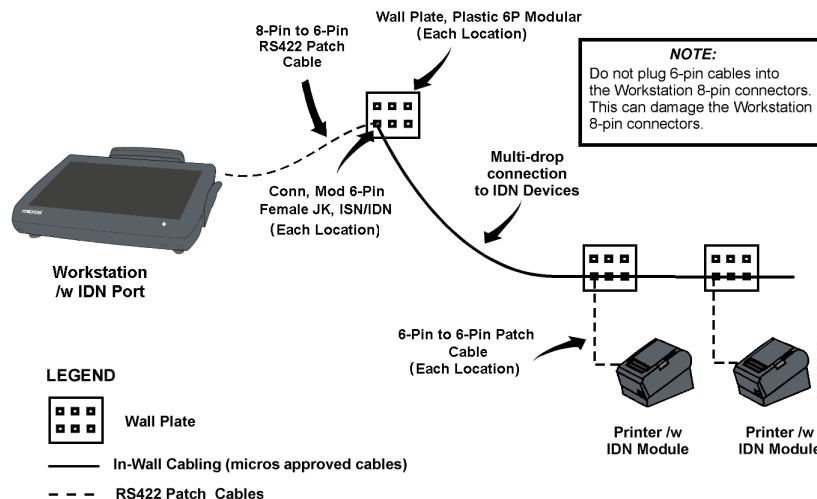

32

Equipment Dimensions

This section includes dimensional drawings for Oracle MICROS Workstations, Tablets, and peripheral equipment.

MICROS Express Station 4 Series Dimensions

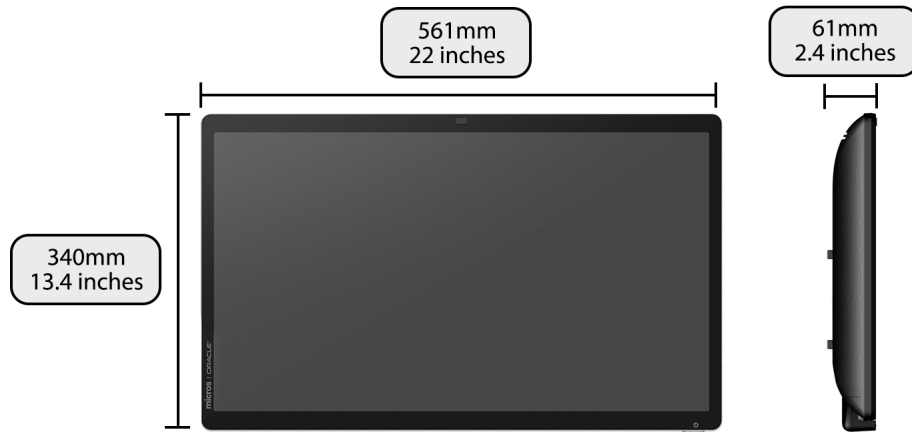

MICROS Workstation 625/655 with Adjustable Stand - Dimensions

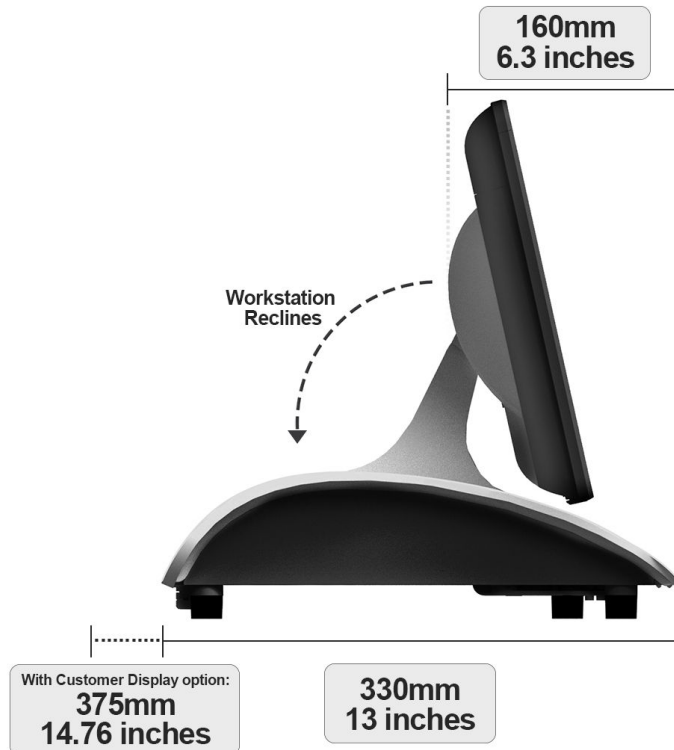
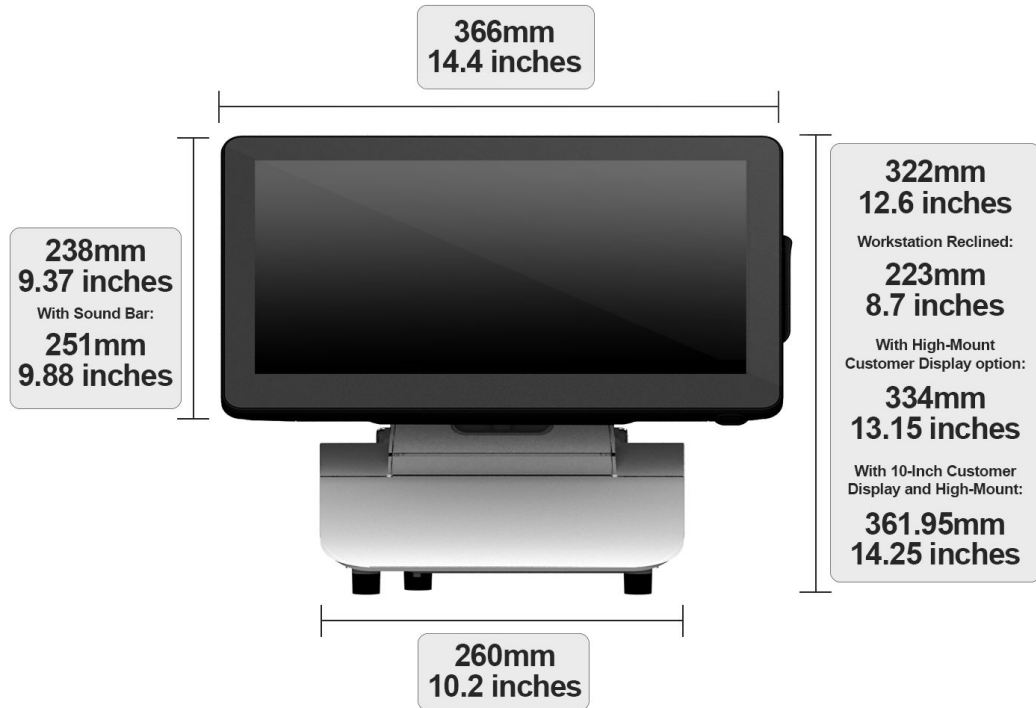

MICROS Compact Workstation 310 with Flexible Stand - Dimensions

Figure 32-1 Dimensions of the Compact Workstation 310 with Flexible Stand



MICROS Compact Workstation 310 with Basic Stand - Dimensions

Figure 32-2 Dimensions of the Compact Workstation 310 with Basic Stand

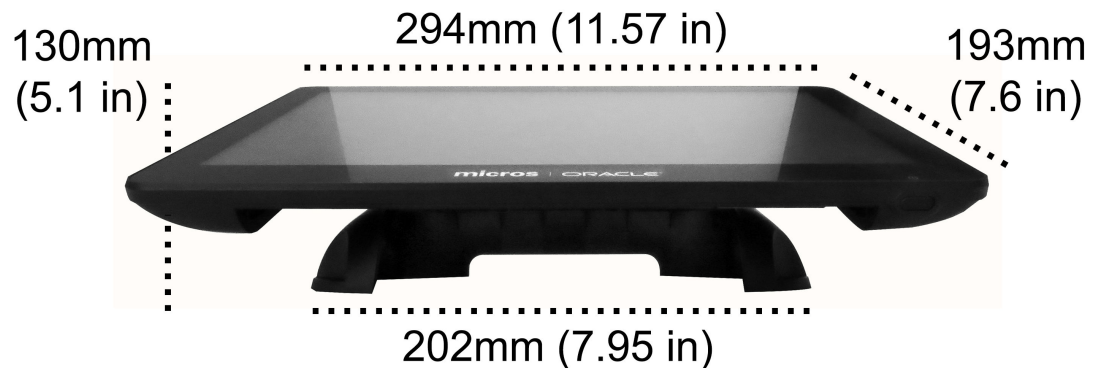

MICROS Tablet 721P - Front and Side Dimensions

Figure 32-3 Oracle MICROS Tablet 721P Dimensions



MICROS Tablet 721 - Front and Side Dimensions

Figure 32-4 Oracle MICROS Tablet 721 Dimensions

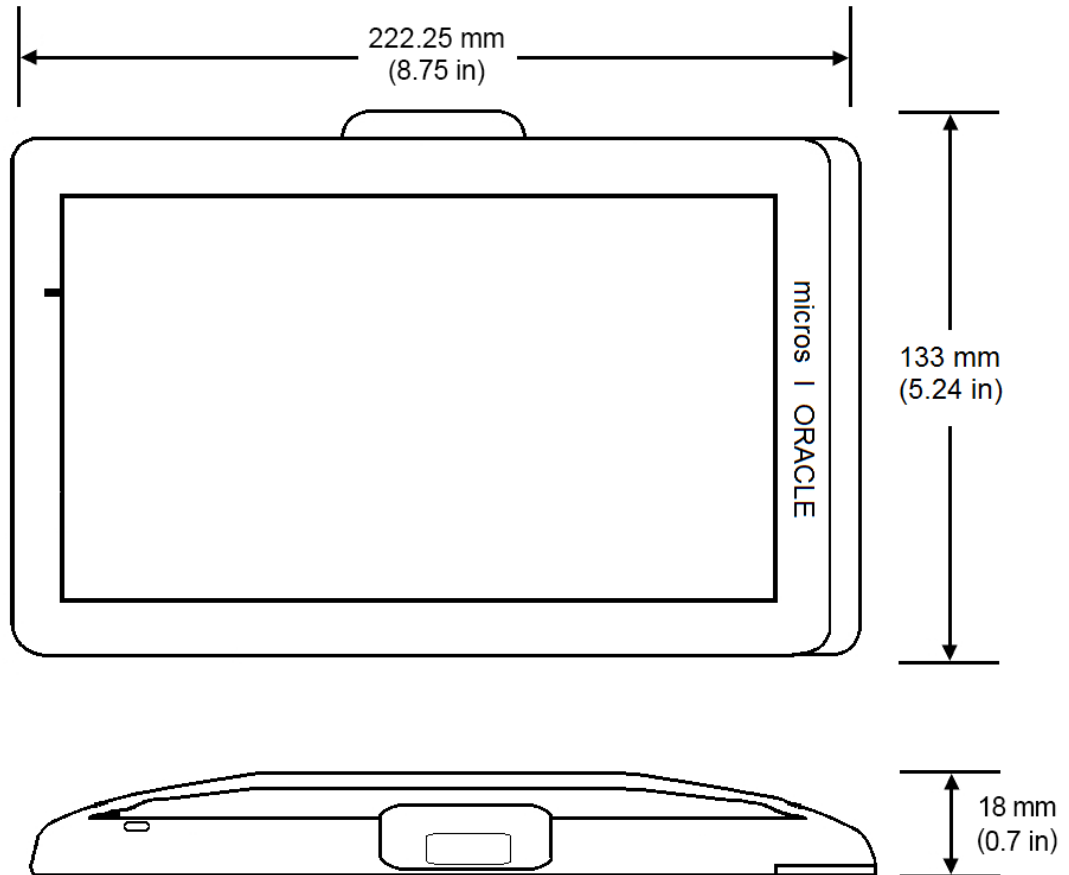

MICROS Tablet 720 - Front and Side Dimensions

Figure 32-5 Tablet 720 Dimensions

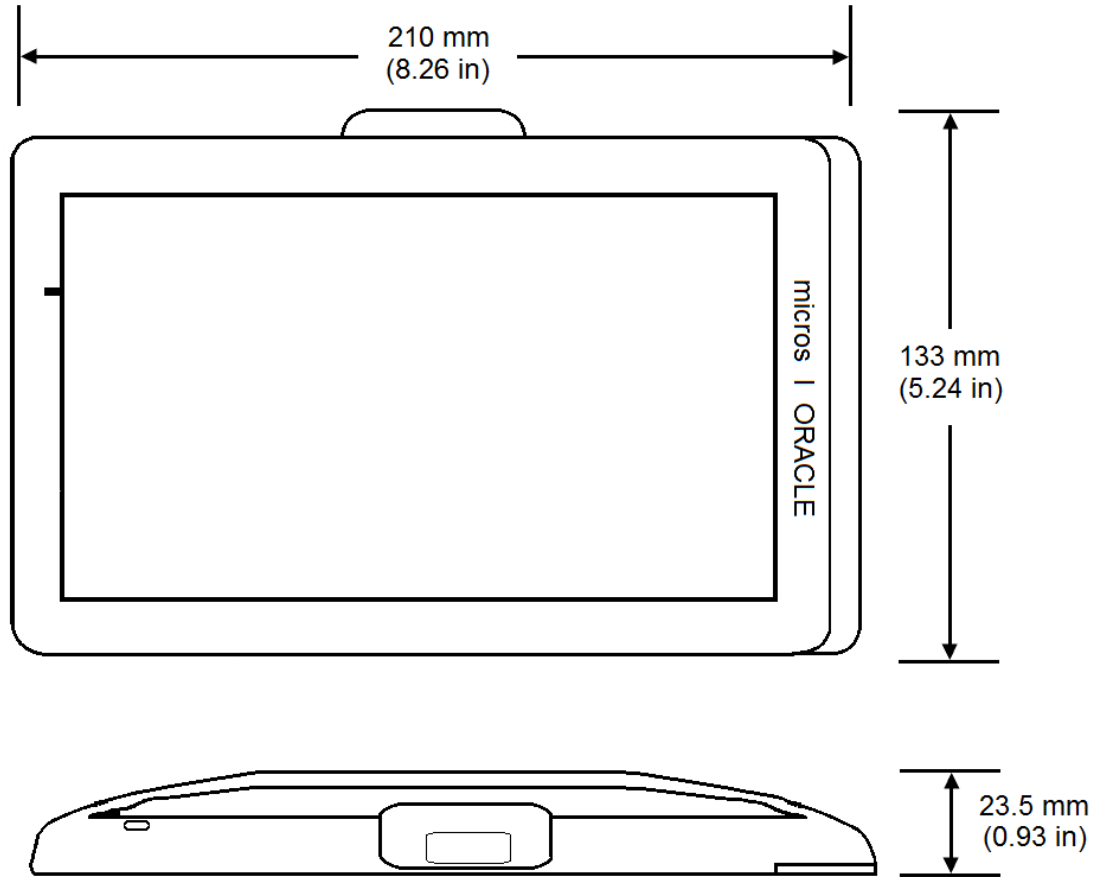

MICROS Tablet 700 Series - 4-Bay Tablet Charger Dimensions

Figure 32-6 Tablet 700 Series 4-Bay Tablet Charger Dimensions

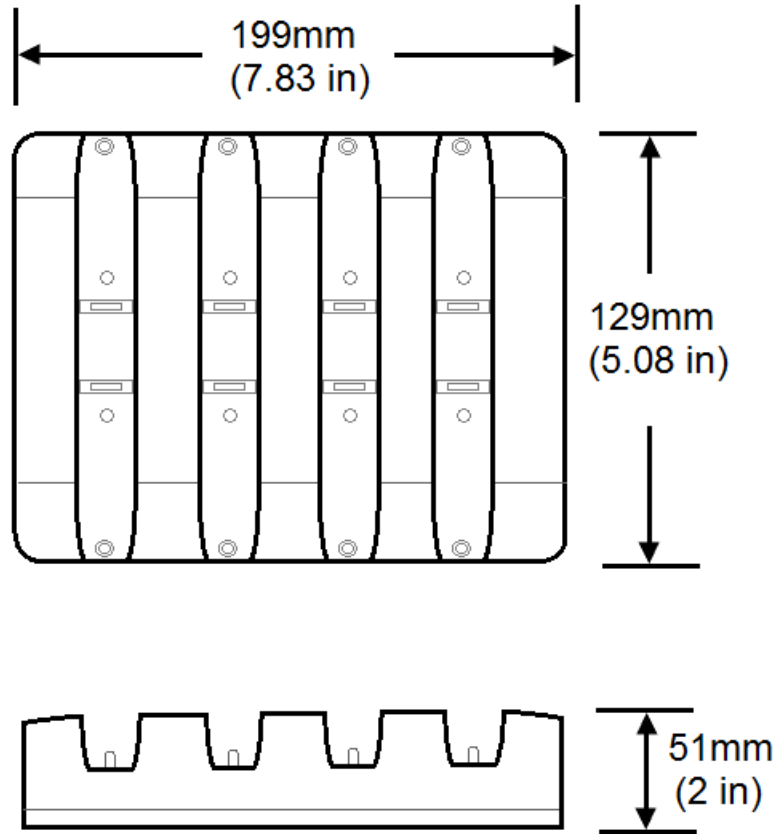

MICROS Tablet 700 Series - 4-Bay Battery Charger Dimensions

Figure 32-7 Tablet 700 Series 4-Bay Battery Charger Dimensions

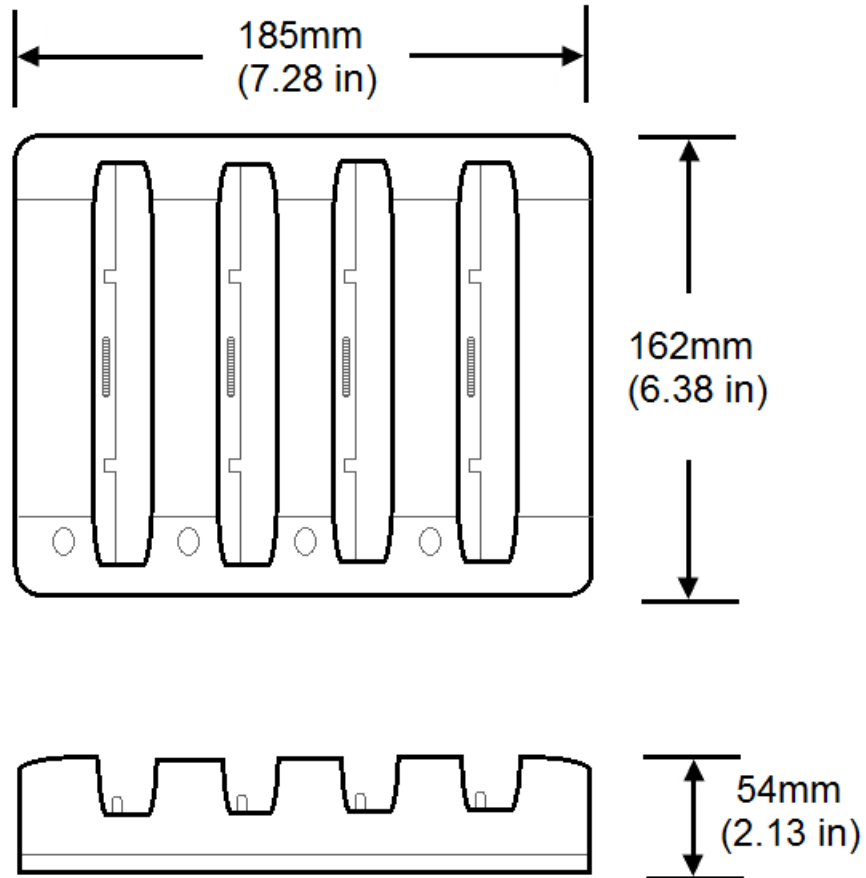

MICROS Workstation 6 Series - Front and Back Dimensions with Adjustable Stand

Figure 32-8 Workstation 6 Series Front Dimensions

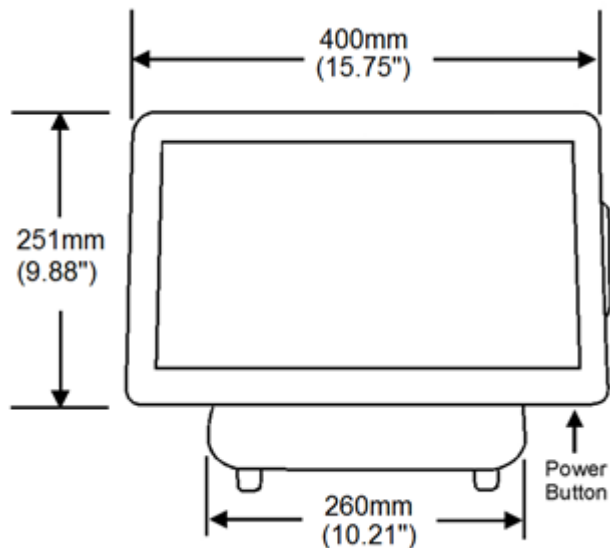
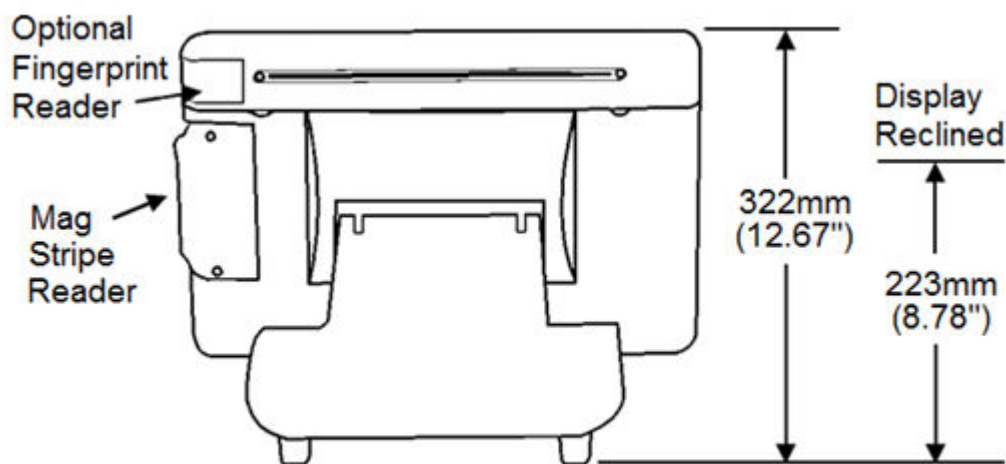
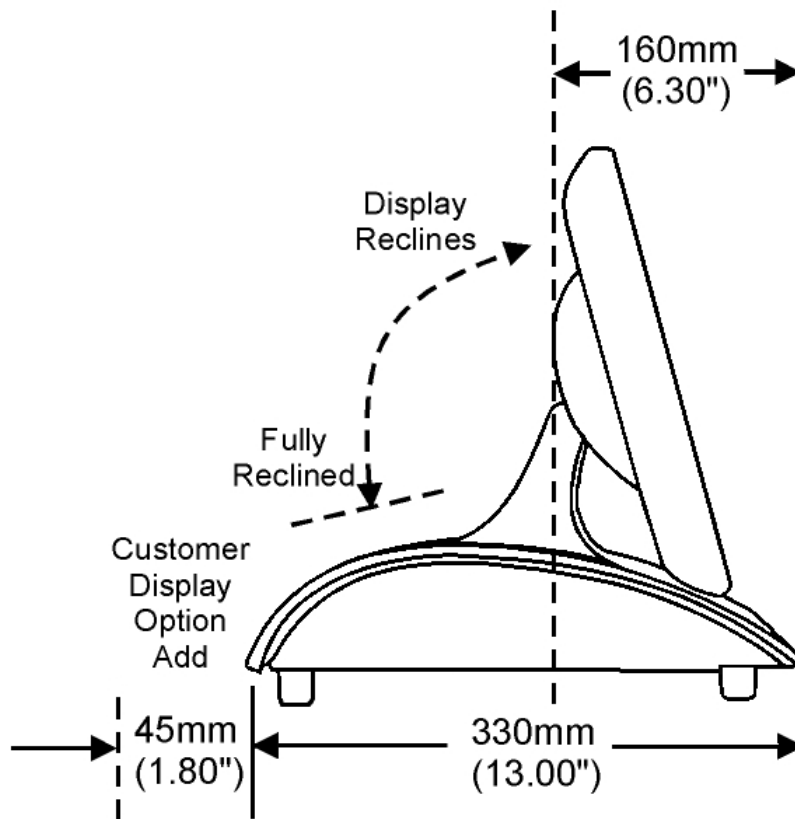

Figure 32-9 Workstation 6 Series Back Dimensions



MICROS Workstation 6 Series - Side Dimensions with Adjustable Stand

Figure 32-10 Workstation 6 Series Side Dimensions



MICROS Workstation 6 Series - Side Dimensions with Adjustable Stand and High-Mount Customer Display

Figure 32-11 Dimensions (Side) with the High-Mount Customer Display

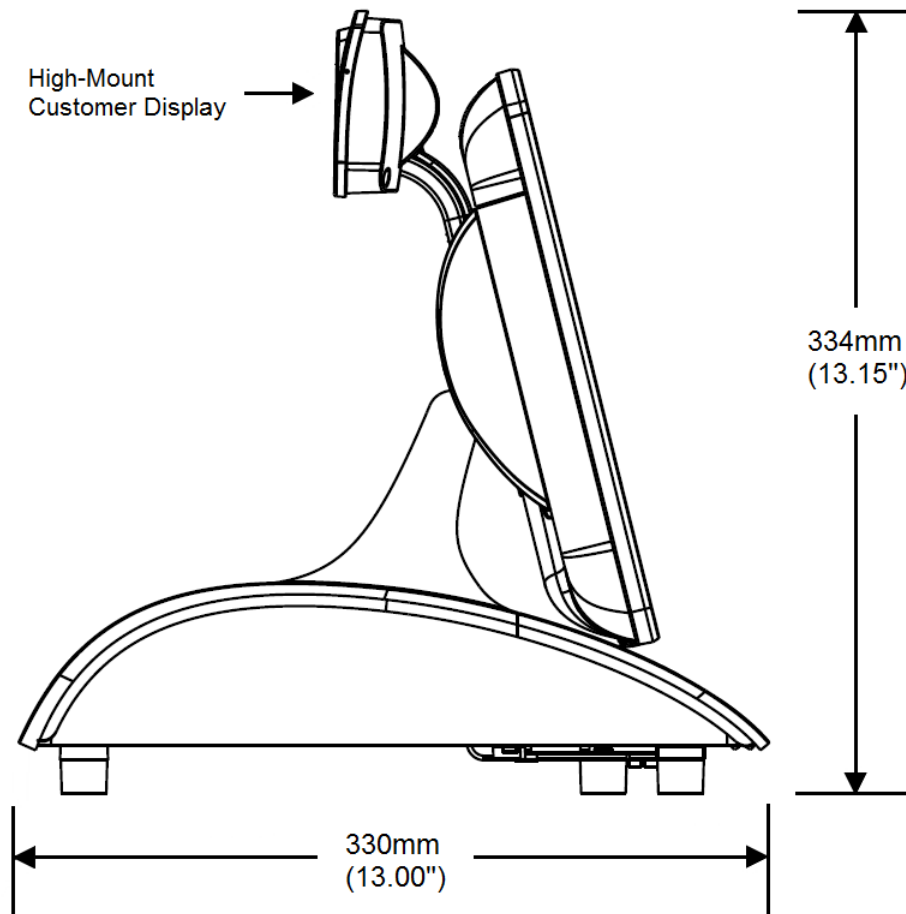

MICROS Workstation 6 Series - Side Dimensions with 10-Inch Customer Display and High Mount

Figure 32-12 Dimensions (Side) of the 10-Inch Customer Display with High Mount

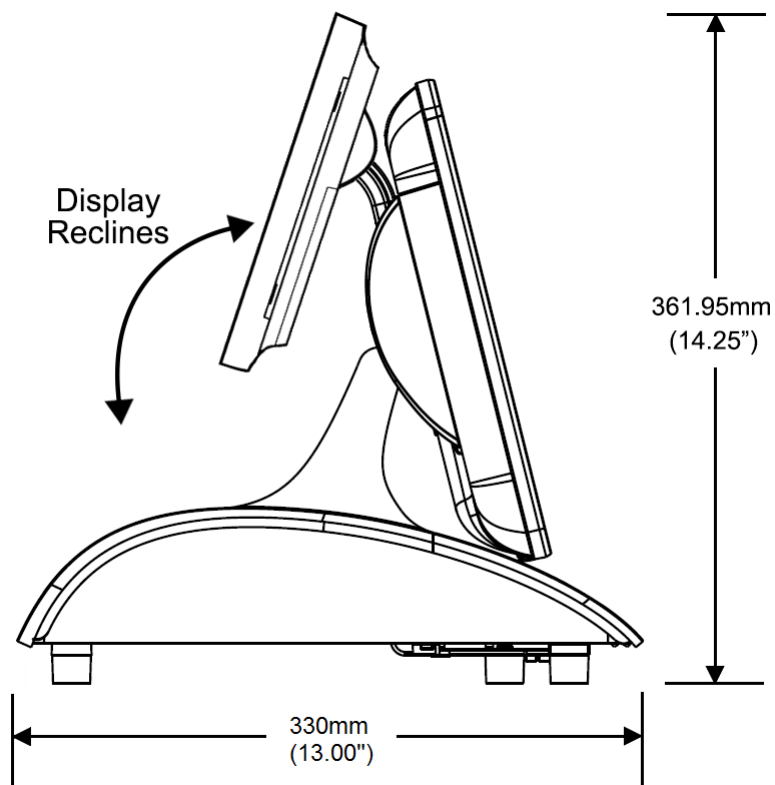

MICROS Workstation 6 Series - 10-Inch Customer Display with Pole Mount Dimensions

Figure 32-13 10-Inch Customer Display with Pole Mount Dimensions

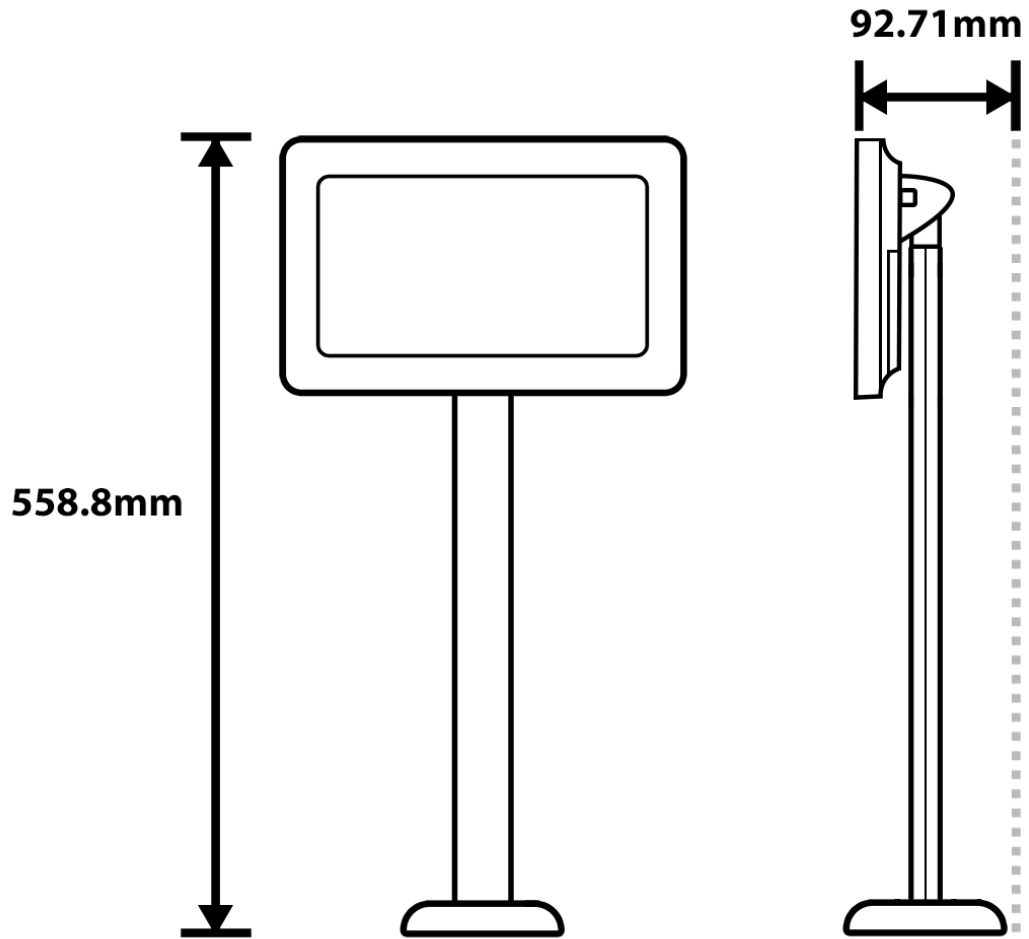

MICROS Workstation 6 Series - Wall Mount Dimensions

Figure 32-14 Workstation 6 Series Wall Mount Dimensions

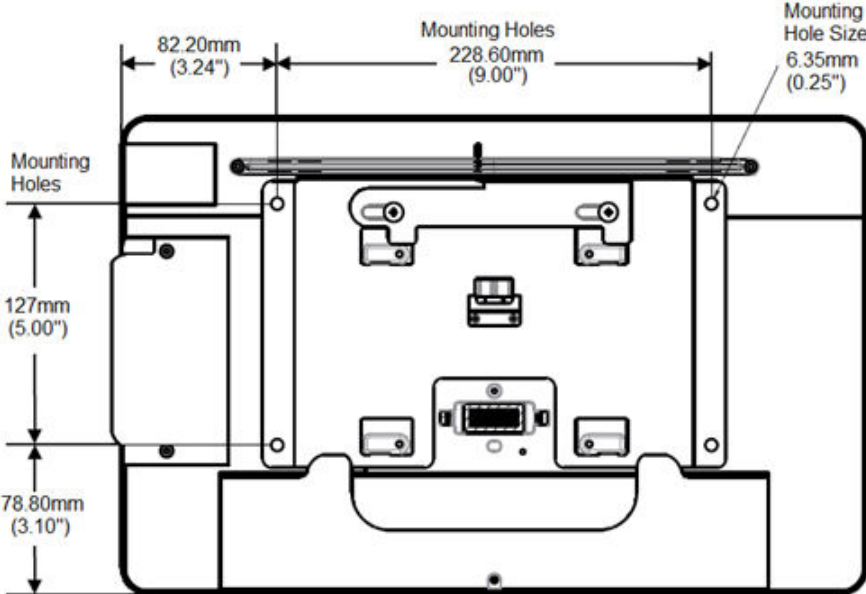
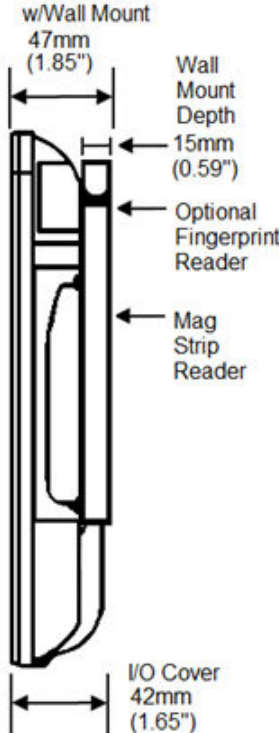
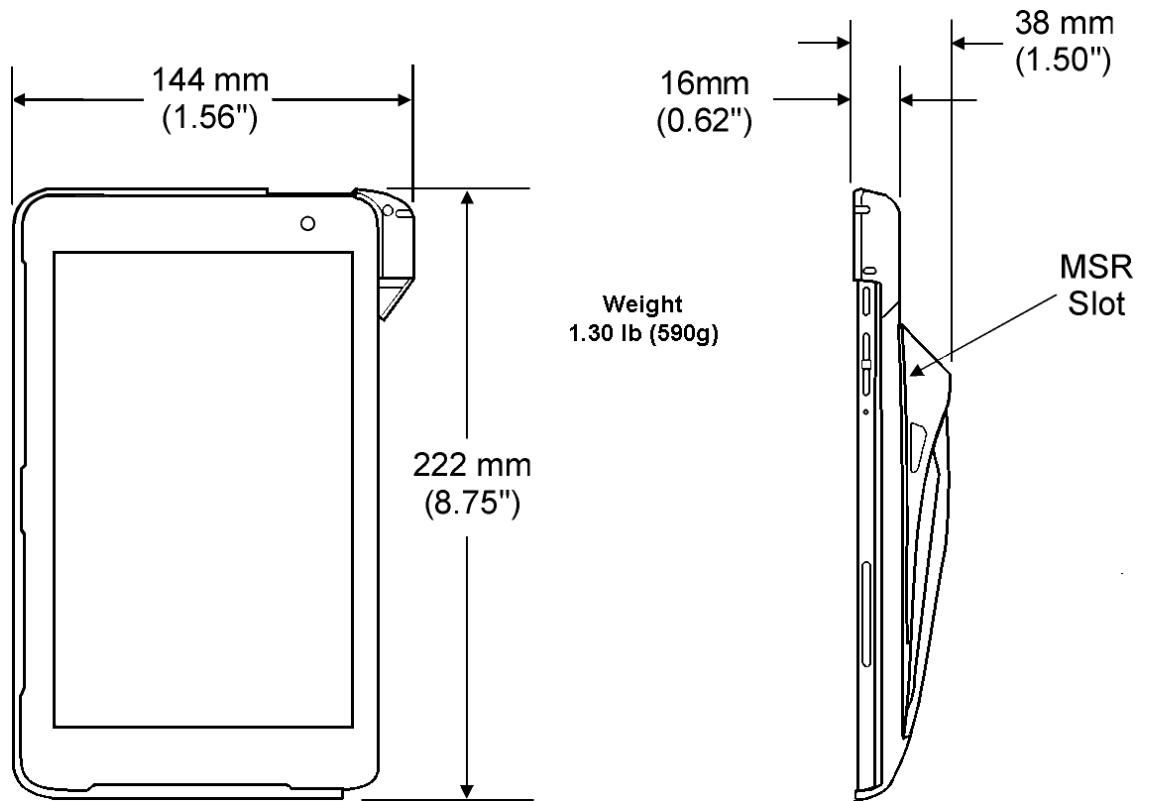

Figure 32-15 Workstation 6 Series Wall Mount Dimensions



MICROS Tablet E-Series 8 Dimension

Figure 32-16 Tablet E-Series 8 Dimensions



MICROS Tablet E-Series 11 Dimensions

Figure 32-17 Tablet E-Series 11 Dimensions

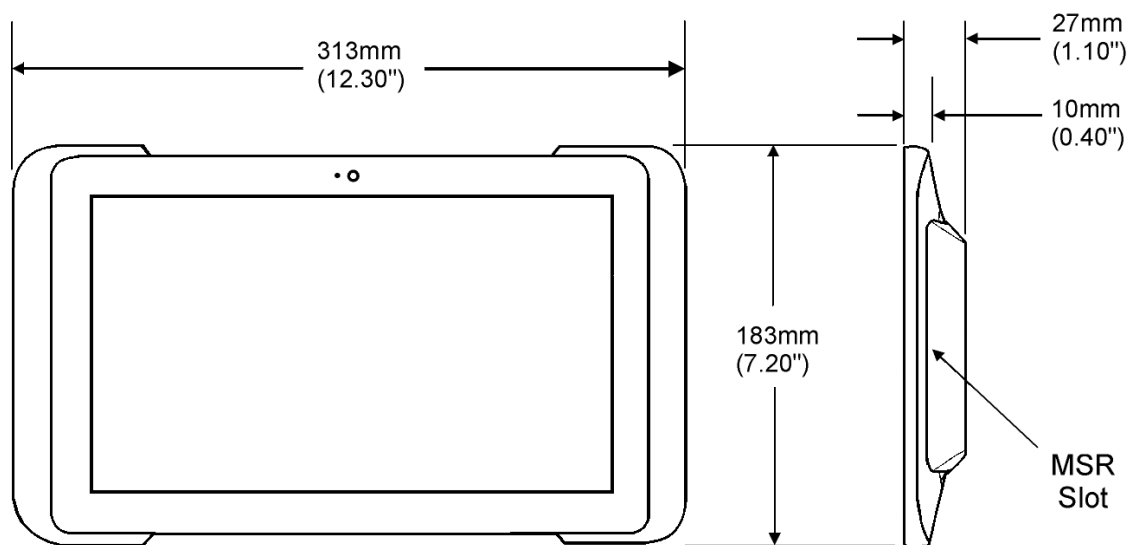

MICROS Tablet E-Series Multi-Unit Charger - Surface Mount Dimensions

Figure 32-18 Tablet E-Series Multi-Unit Charger - Surface Mount Dimensions

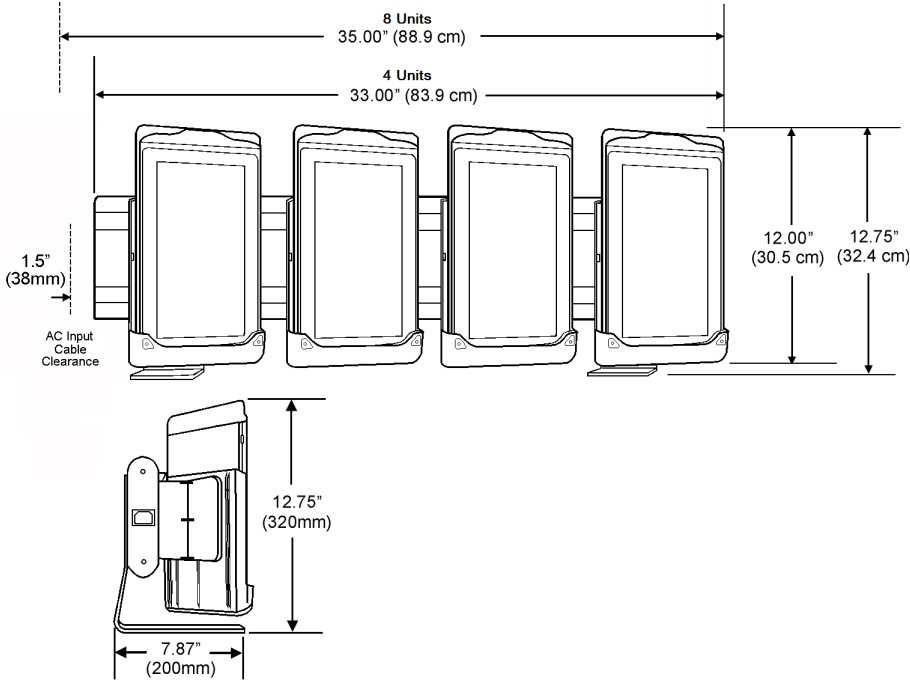

MICROS Tablet E-Series Multi-Unit Charger - Wall Mount Dimensions

Figure 32-19 Tablet E-Series Multi-Unit Charger - Wall Mount Dimensions

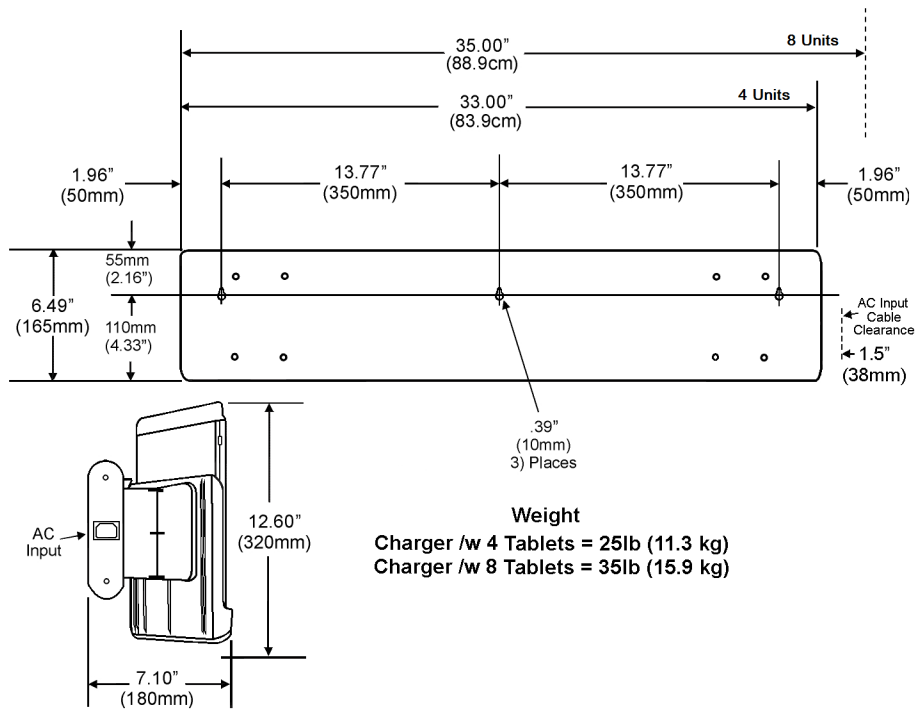

MICROS Tablet R-Series Dimensions

Figure 32-20 Tablet R-Series Dimensions

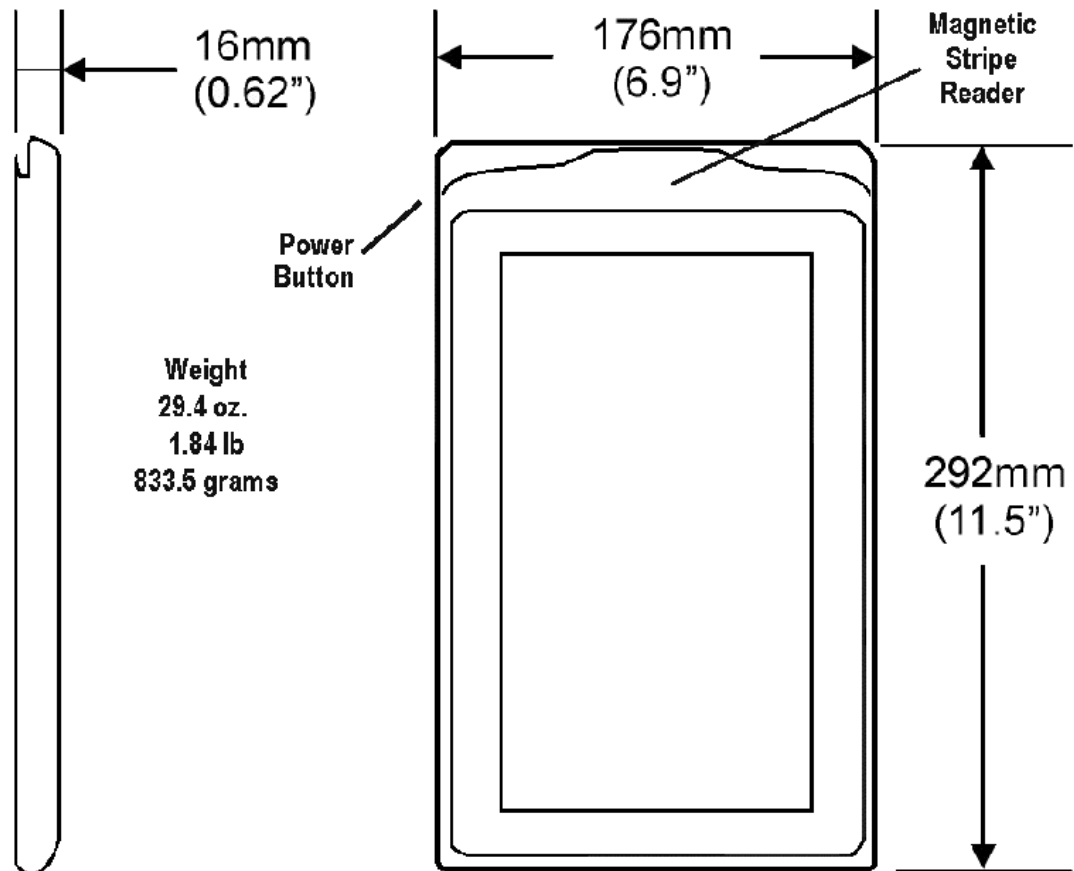

MICROS Tablet R-Series - Base Station Dimensions with Peripherals

Figure 32-21 Tablet R-Series on Base Station Dimensions with Peripherals

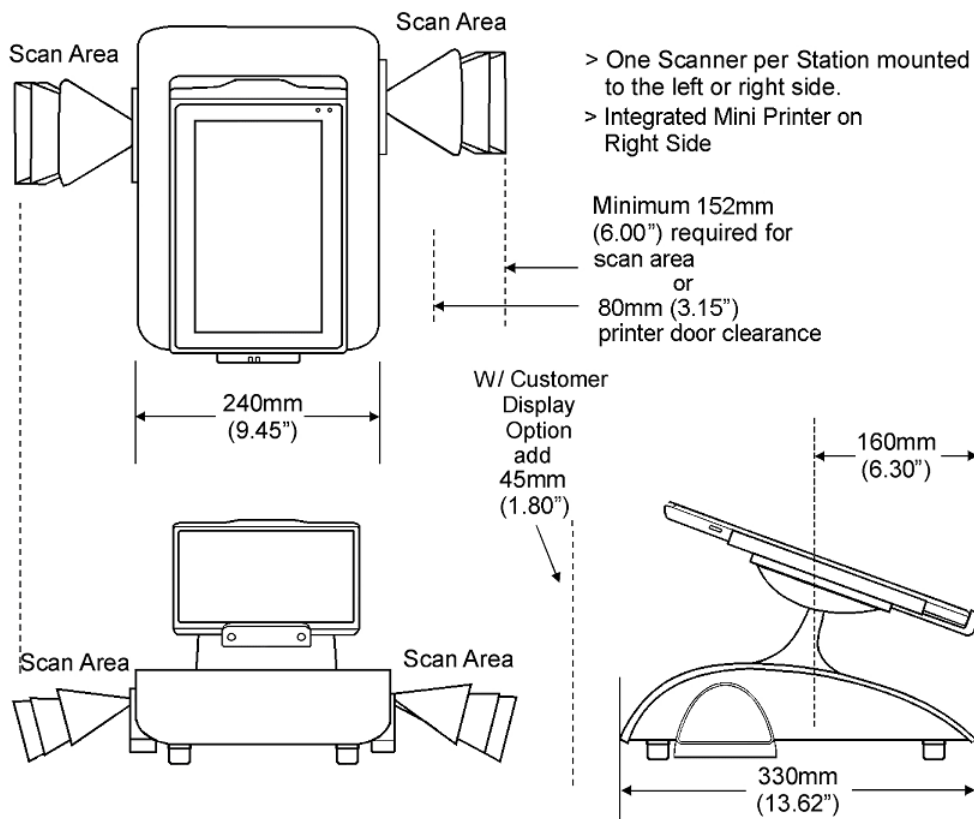

MICROS PC Workstation 2015 - Low Profile Dimensions

Figure 32-22 PC Workstation 2015 - Low Profile Dimensions

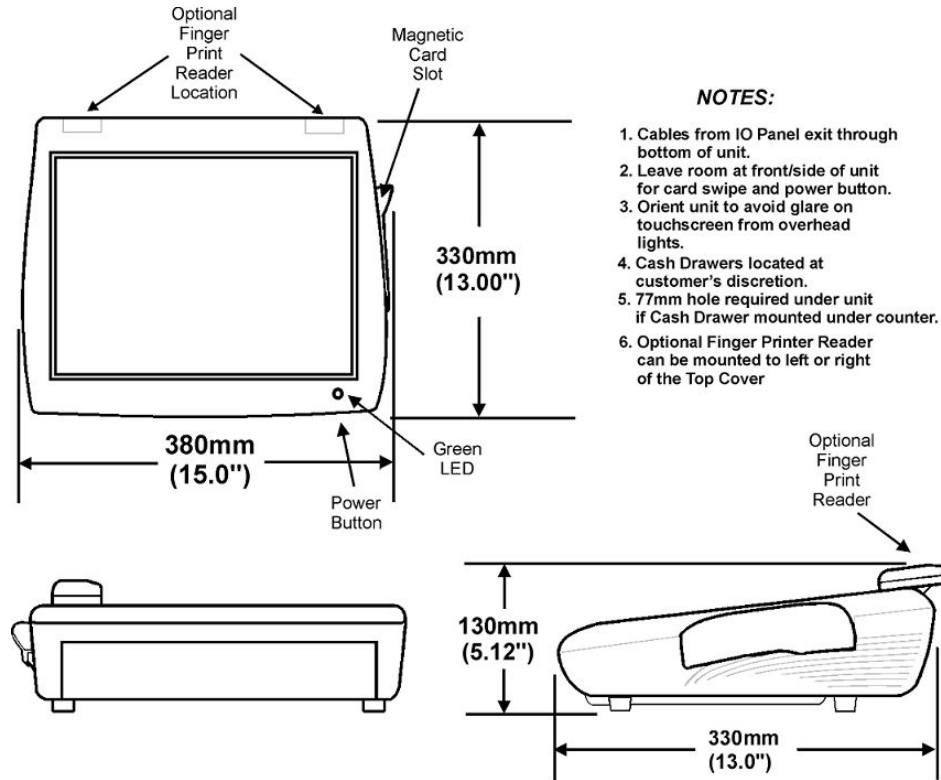

MICROS PC Workstation 2015 - Low Profile with Customer Facing Display Dimensions

Figure 32-23 PC Workstation 2015 - Low Profile with Customer Facing Display Dimensions

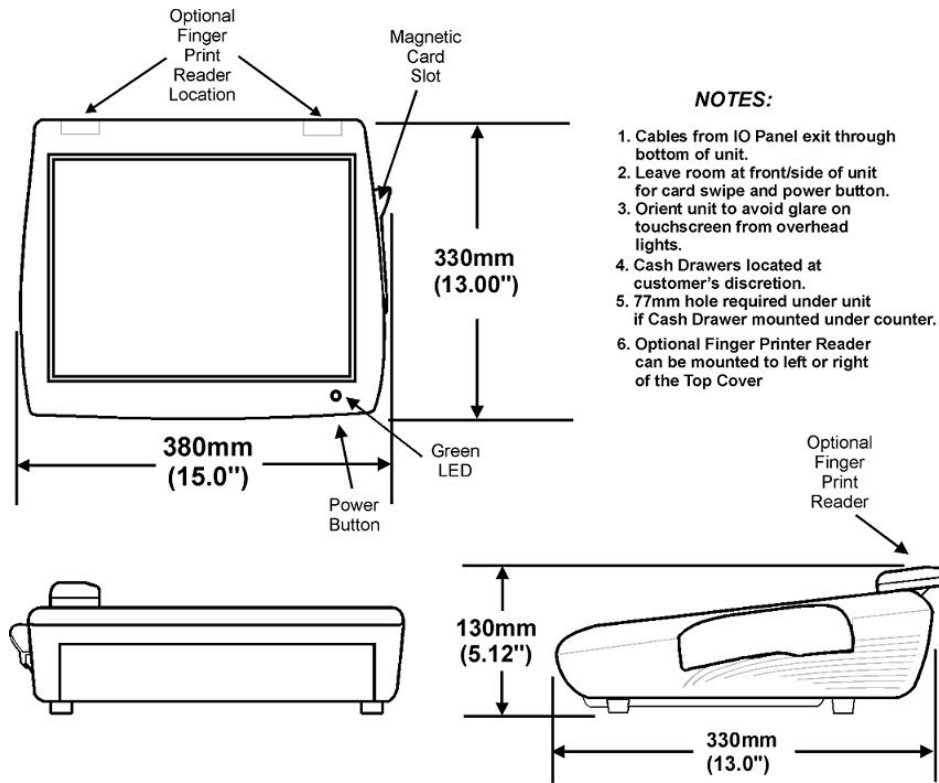

MICROS PC Workstation 2015 Adjustable Stand Dimensions

Figure 32-24 PC Workstation 2015 Adjustable Stand Dimensions

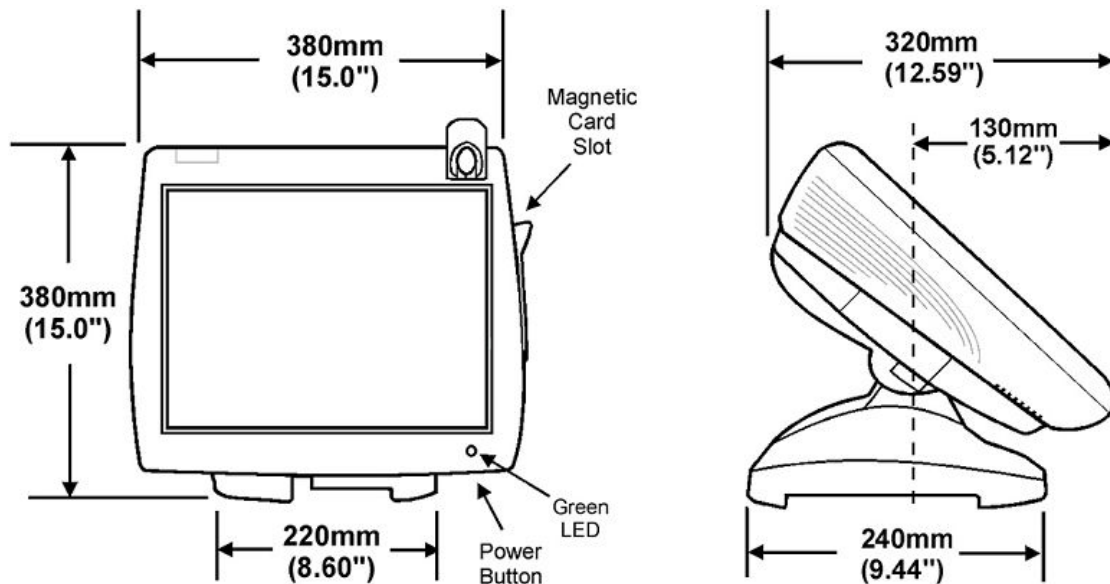

MICROS PC Workstation 2015 on Stand - LCD Customer Display Dimensions

Figure 32-25 PC Workstation 2015 on Stand - LCD Customer Display Dimensions

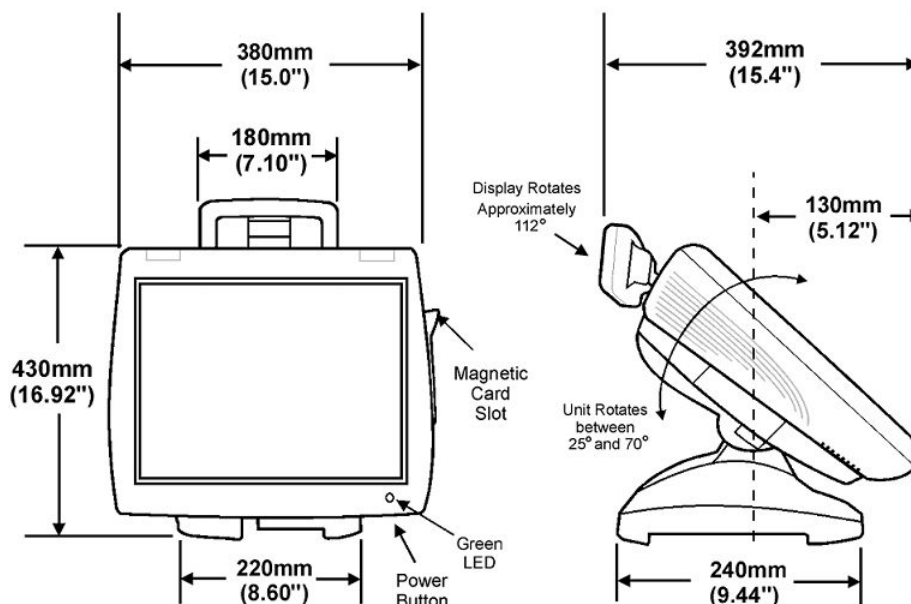

MICROS PC Workstation 2015 - Adjustable Stand Protégé Customer Display Dimensions

Figure 32-26 PC Workstation 2015 - Adjustable Stand Protégé Customer Display Dimensions

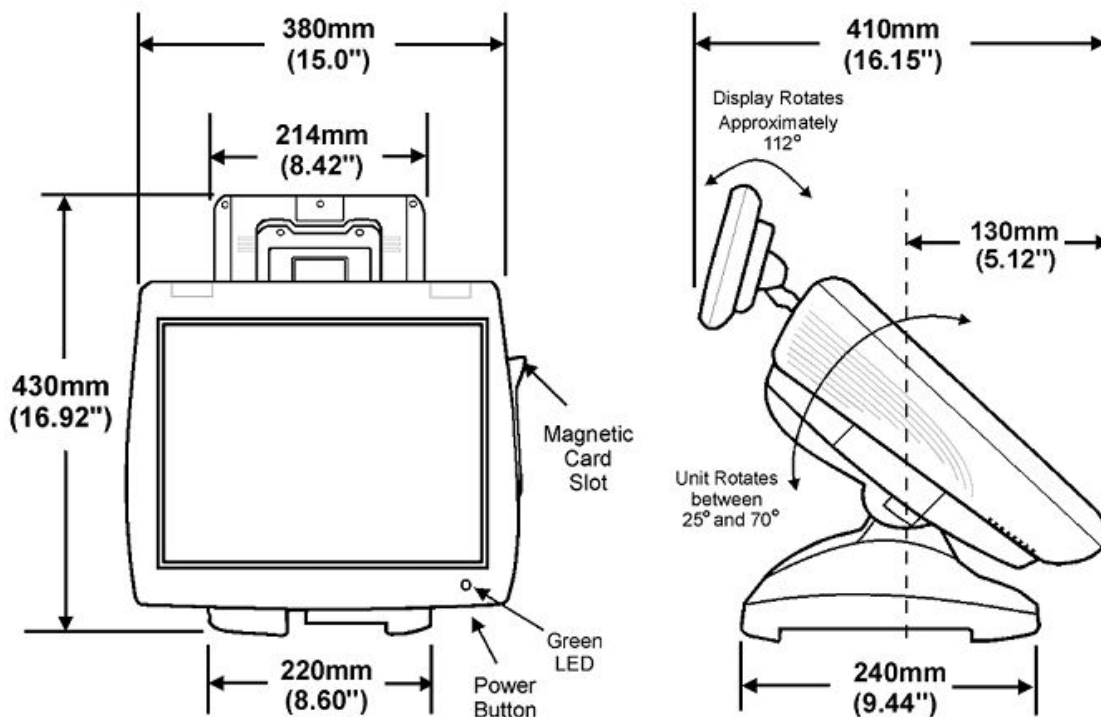

MICROS Workstation 5/5A - Low Profile Dimensions

Figure 32-27 Workstation 5/5A - Low Profile Dimensions

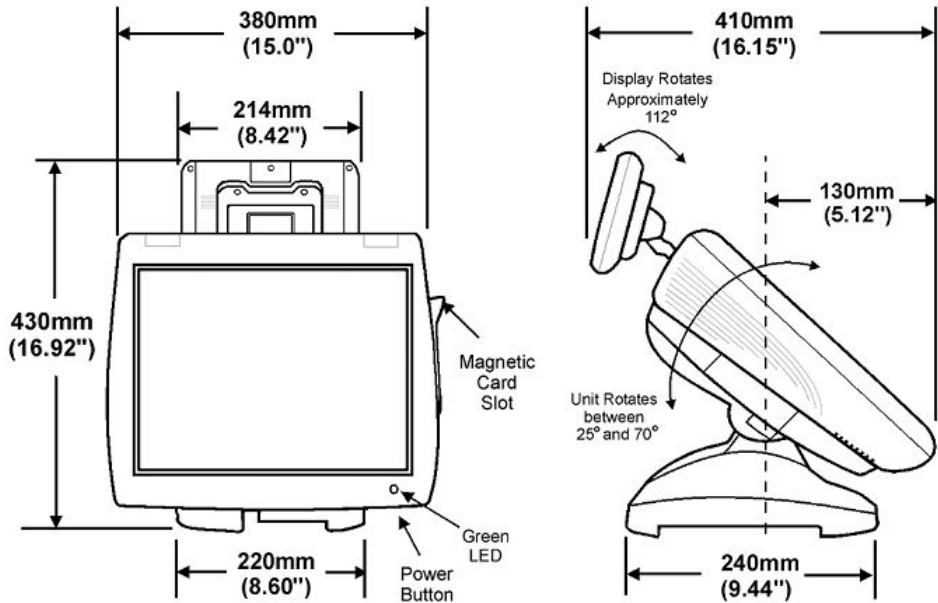

MICROS Workstation 5/5A Dimensions with Integrated LCD Customer Display

Figure 32-28 Workstation 5/5A Dimensions with Integrated LCD Customer Display

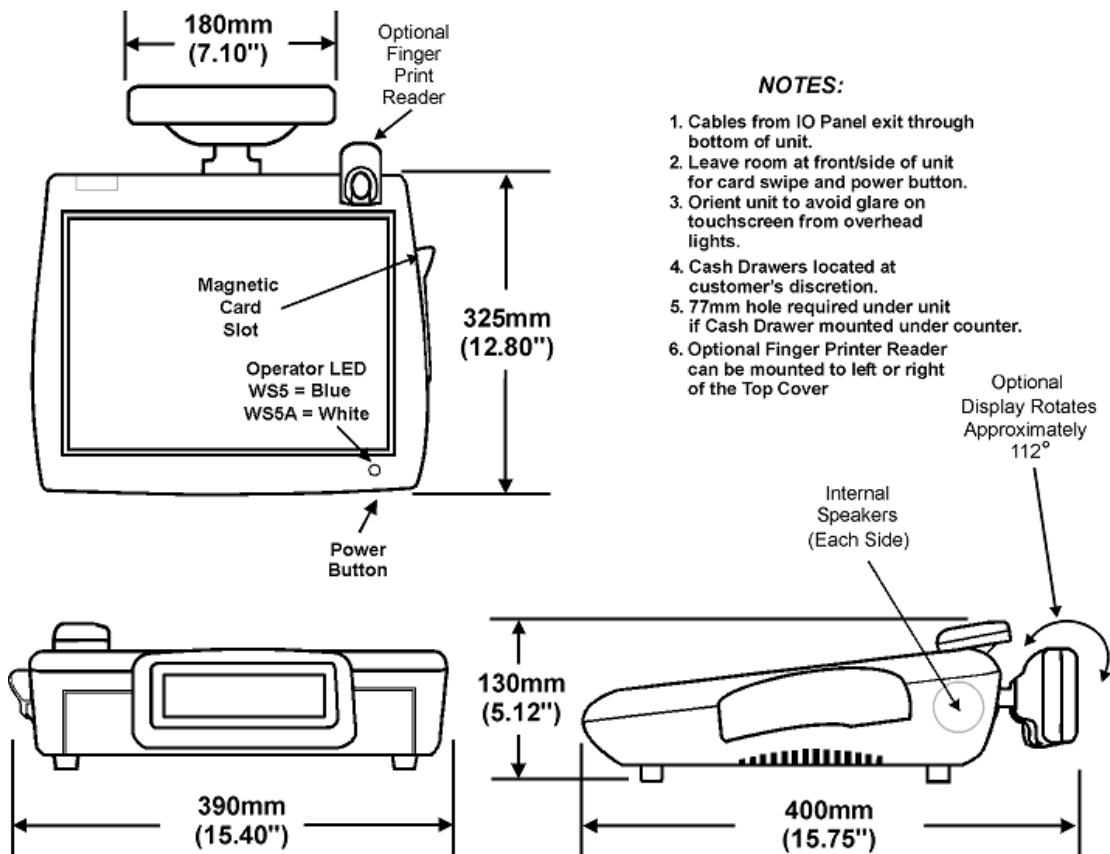

MICROS Workstation 5/5A Dimensions on Adjustable Stand

Figure 32-29 Workstation 5/5A Dimensions on Adjustable Stand

NOTES:

1. Cables from IO Panel routed through cable slot to exit stand
2. Leave room at front/side of unit for card swipe and power button.
3. Orient unit to avoid glare on touchscreen from overhead lights.
4. Cash Drawers located at customer's discretion.
5. 77mm hole required under unit if Cash Drawer mounted under counter.
6. Optional Finger Printer Reader can be mounted to left or right of the Top Cover

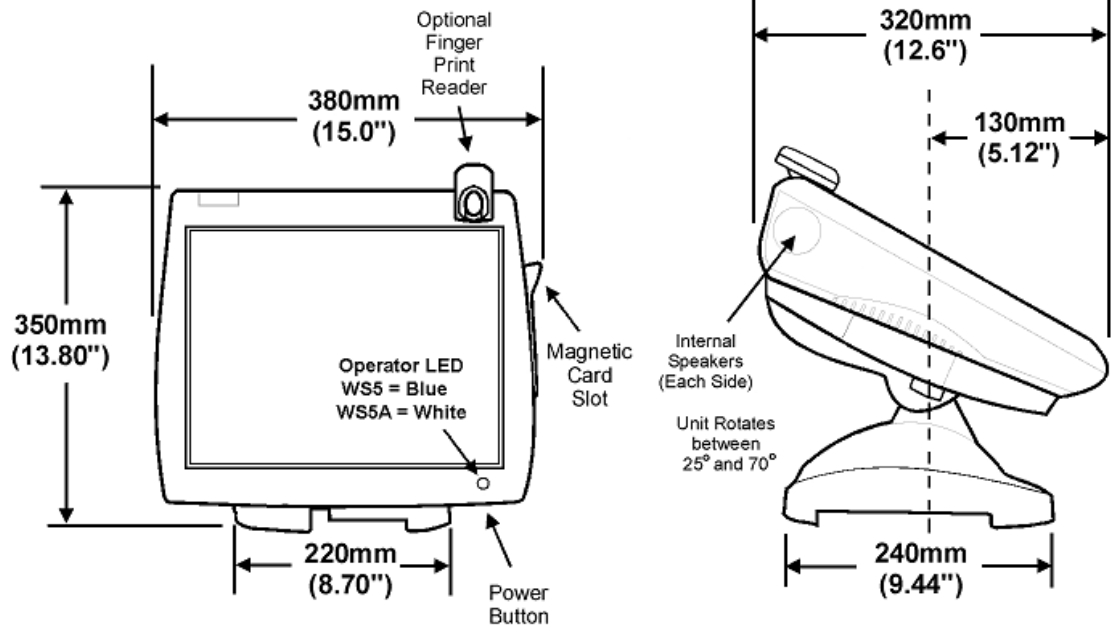

MICROS Workstation 5/5A Dimensions on Stand with LCD Customer Display

Figure 32-30 Workstation 5/5A Dimensions on Stand with LCD Customer Display

NOTES:

1. Cables from IO Panel routed through cable slot to exit stand
2. Leave room at front/side of unit for card swipe and power button.
3. Orient unit to avoid glare on touchscreen from overhead lights.
4. Cash Drawers located at customer's discretion.
5. 77mm hole required under unit if Cash Drawer mounted under counter.
6. Optional Finger Printer Reader can be mounted to left or right of the Top Cover

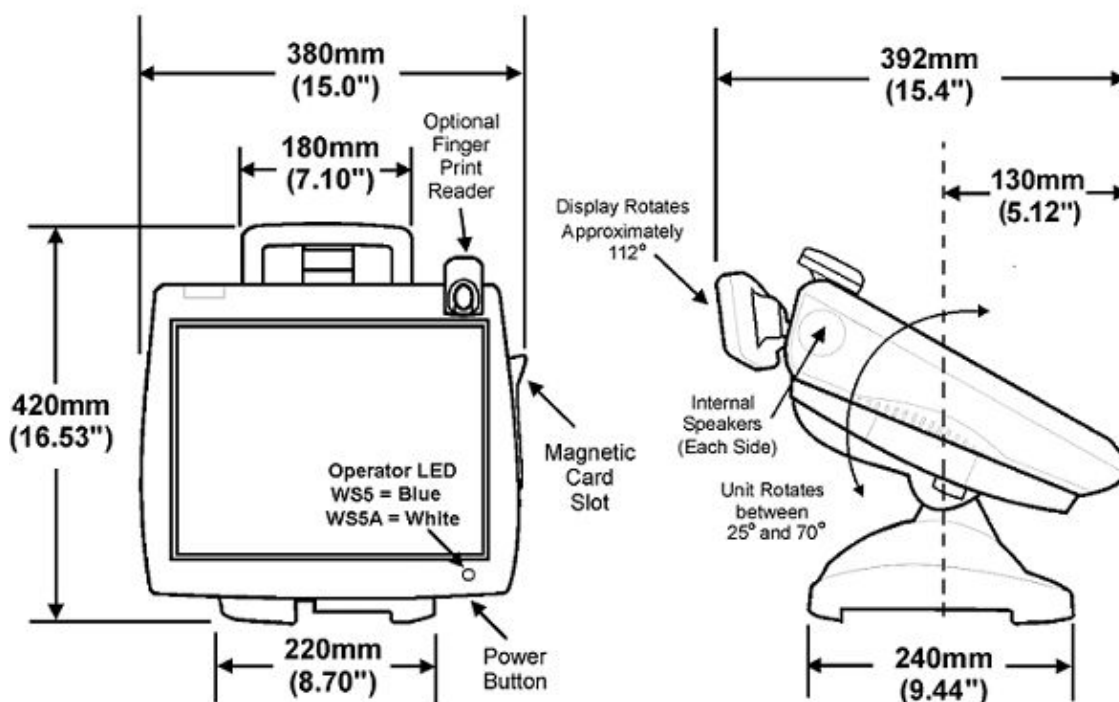

MICROS Workstation 5/5A Dimensions on Stand with Protégé Customer Display

Figure 32-31 Workstation 5/5A Dimensions on Stand with Protégé Customer Display

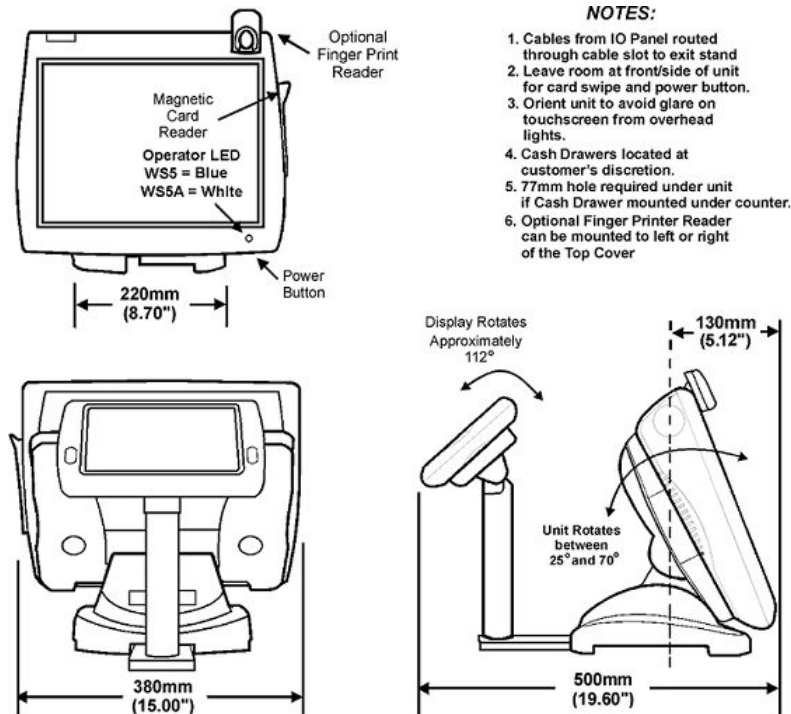

MICROS Workstation 5/5A Dimensions on Stand /w Vivo Payment Terminal

Figure 32-32 Workstation 5/5A Dimensions on Stand /w Vivo Payment Terminal

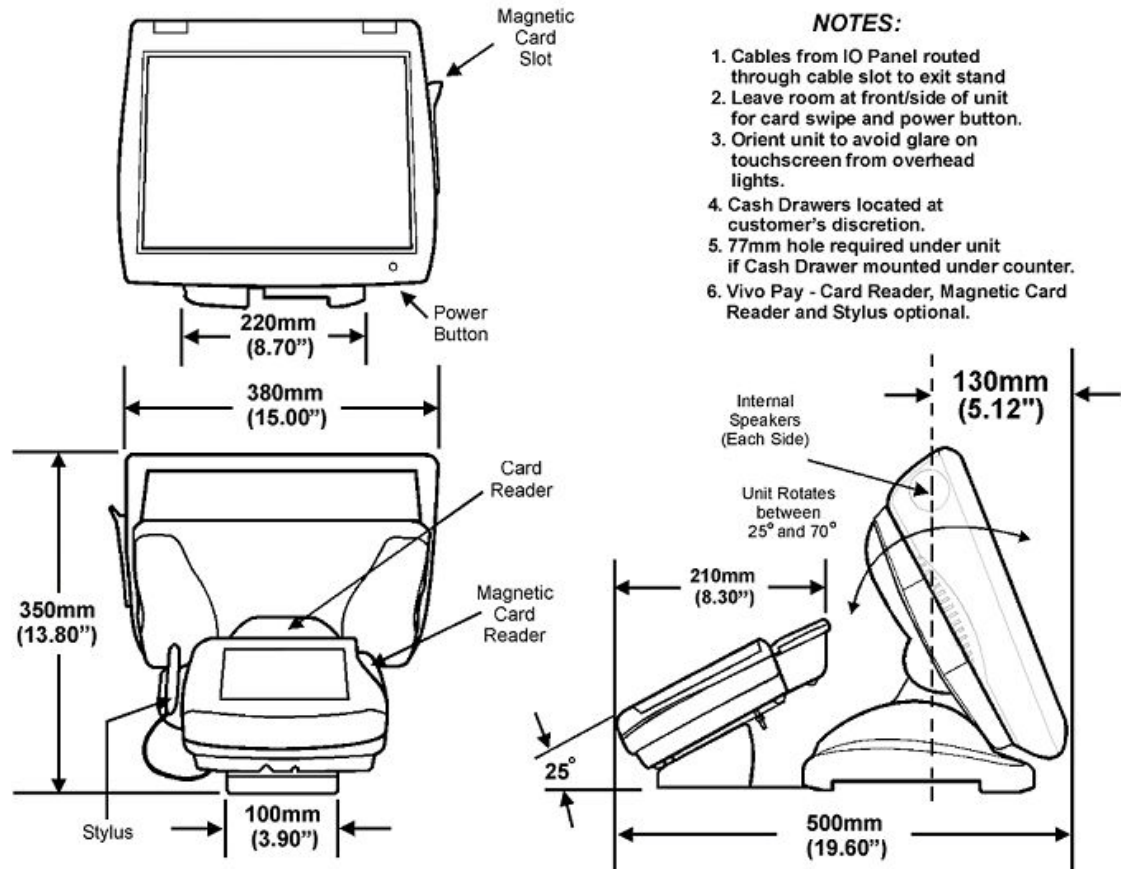

MICROS Workstation 4/4 LX - Low Profile (LP) Dimensions

Figure 32-33 Workstation 4/4 LX - Low Profile (LP) Dimensions

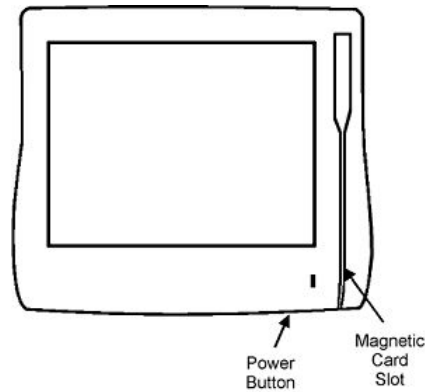

NOTES:

1. Cables exit from rear of unit.
2. Leave room at front/side of unit for card swipe and power button.
3. Orient unit to avoid glare on touchscreen from overhead lights.
4. Cash Drawers located at customer's discretion.
5. 77mm hole required under unit if Cash Drawer mounted under counter.

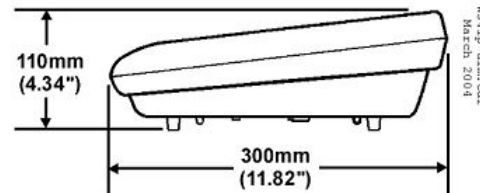
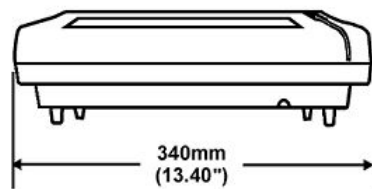

MICROS Workstation 4/4 LX – Low Profile with Rear Customer Display Dimensions

Figure 32-34 Workstation 4/4 LX – Low Profile with Rear Customer Display Dimensions

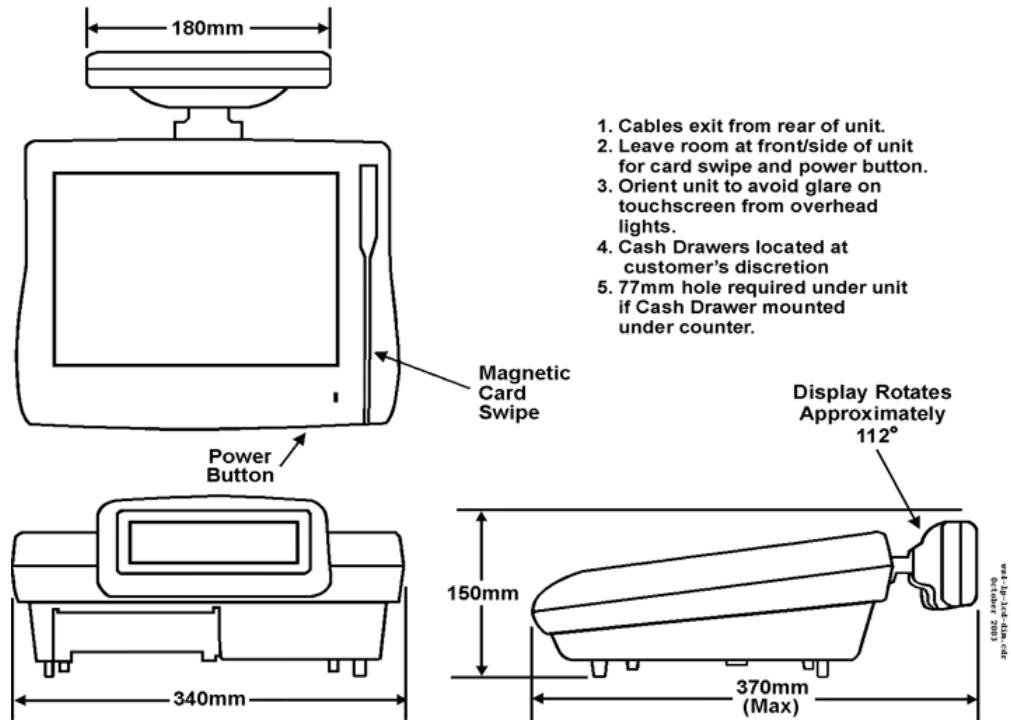

MICROS Workstation 4/4 LX Dimensions on Adjustable Stand

Figure 32-35 Workstation 4/4 LX Dimensions on Adjustable Stand

NOTES:

- 1. Cables from IO Panel routed through cable slot to exit stand
- 2. Leave room at front/side of unit for card swipe and power button.
- 3. Orient unit to avoid glare on touchscreen from overhead lights.
- 4. Cash Drawers located at customer's discretion.
- 5. 77mm hole required under unit if Cash Drawer mounted under counter.

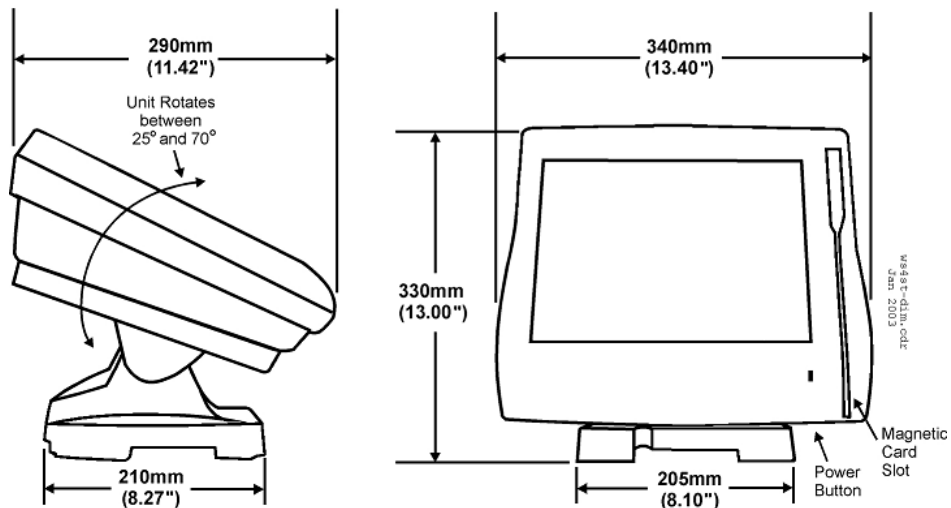

MICROS Workstation 4/4 LX Dimensions on Stand with LCD Customer Display

Figure 32-36 Workstation 4/4 LX Dimensions on Stand with LCD Customer Display

NOTES:

1. Cables from IO Panel routed through cable slots to exit stand
2. Leave room at front/side of unit for card swipe and power button.
3. Orient unit to avoid glare on touchscreen from overhead lights.
4. Cash Drawers located at customer's discretion.
5. 77mm hole required under unit if Cash Drawer mounted under counter.

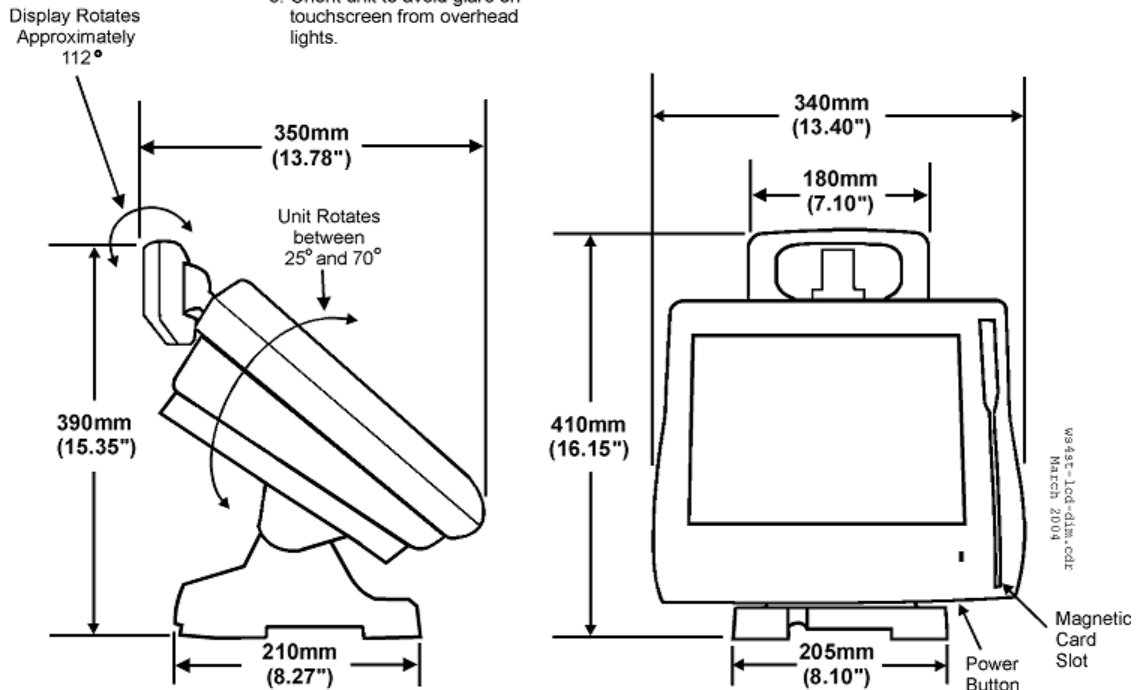

MICROS Workstation 4/4 LX Dimensions on Stand with VFD Customer Display

Figure 32-37 Workstation 4/4 LX Dimensions on Stand with VFD Customer Display

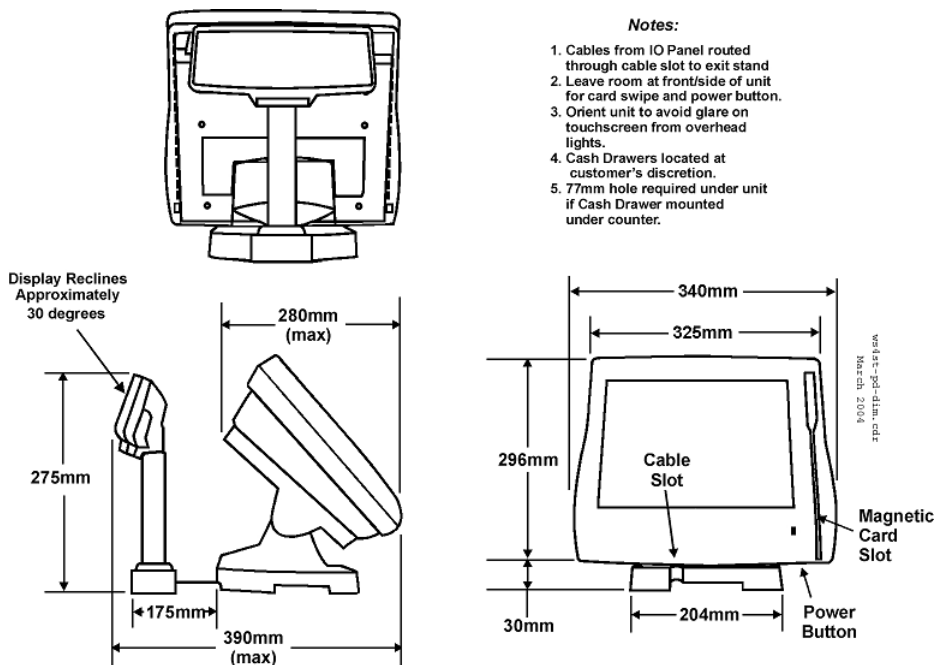

MICROS Workstation 4/4 LX Dimensions on Wall Mount Bracket

Figure 32-38 Workstation 4/4 LX Dimensions on Wall Mount Bracket

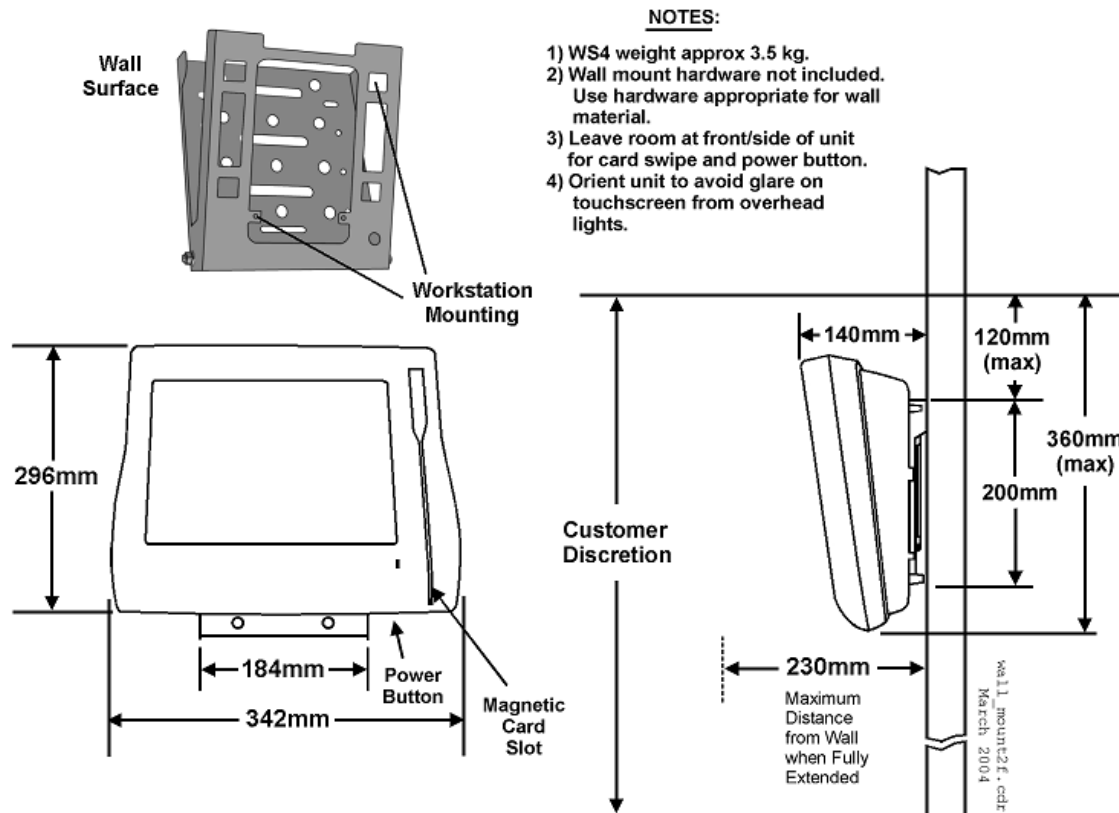

MICROS KW270 Low Profile Dimensions

Figure 32-39 KW270 Low Profile Dimensions

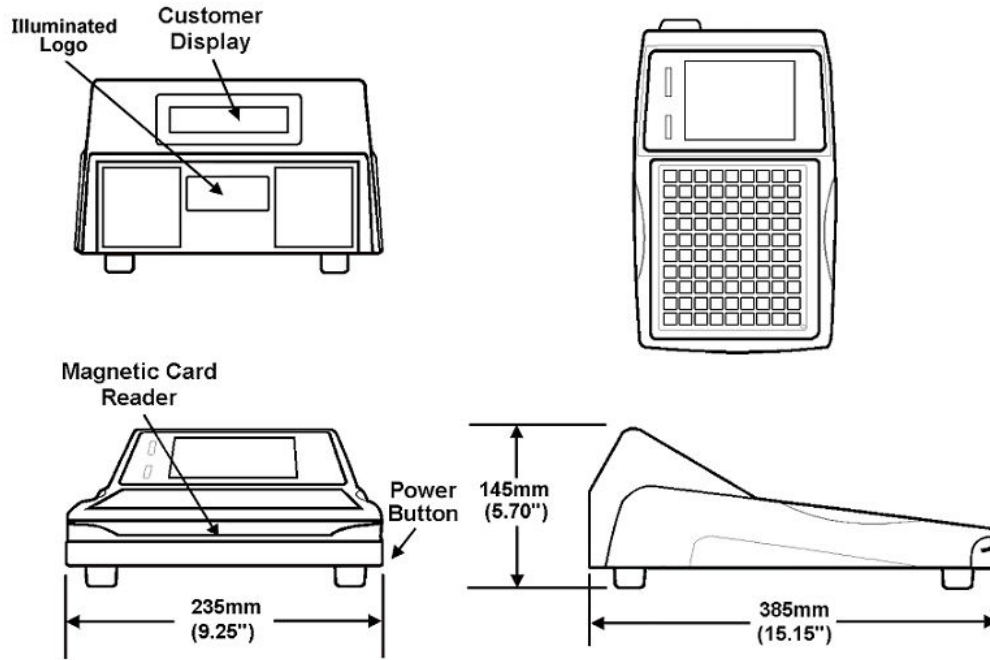

MICROS KW270 on Stand with Updated Scanner Housing Dimensions

Figure 32-40 KW270 on Stand with Updated Scanner Housing Dimensions

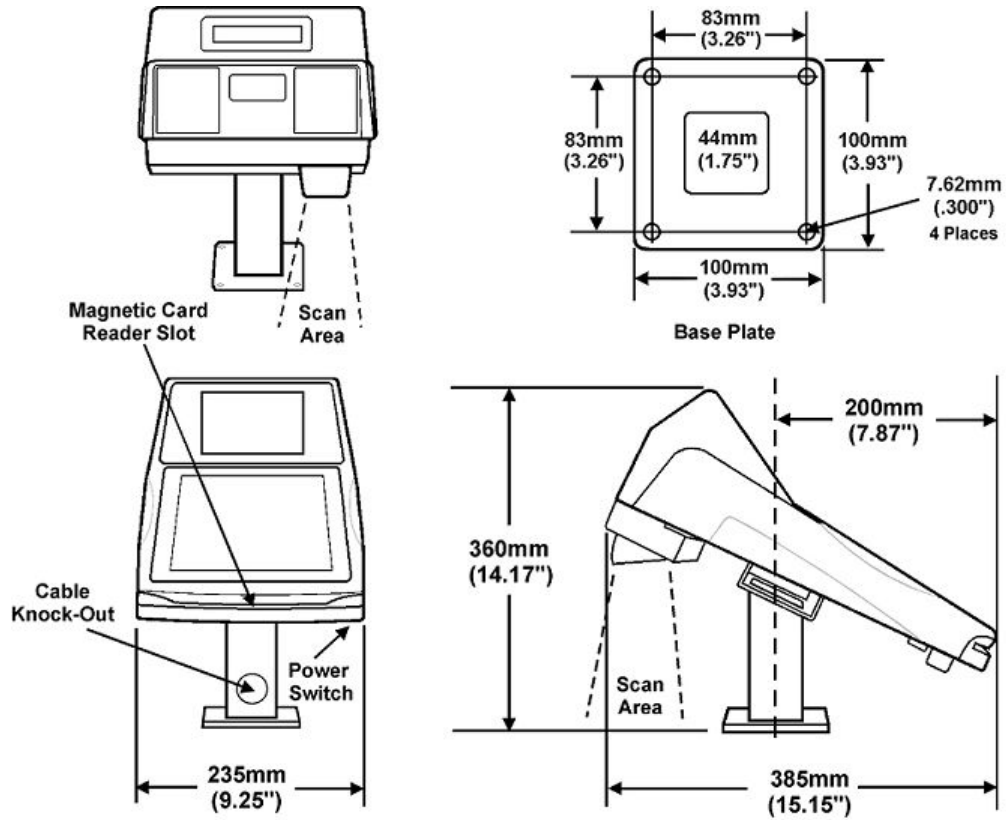

Order Confirmation Controller and Wall Bracket Dimensions

Figure 32-41 Order Confirmation Controller and Wall Bracket Dimensions

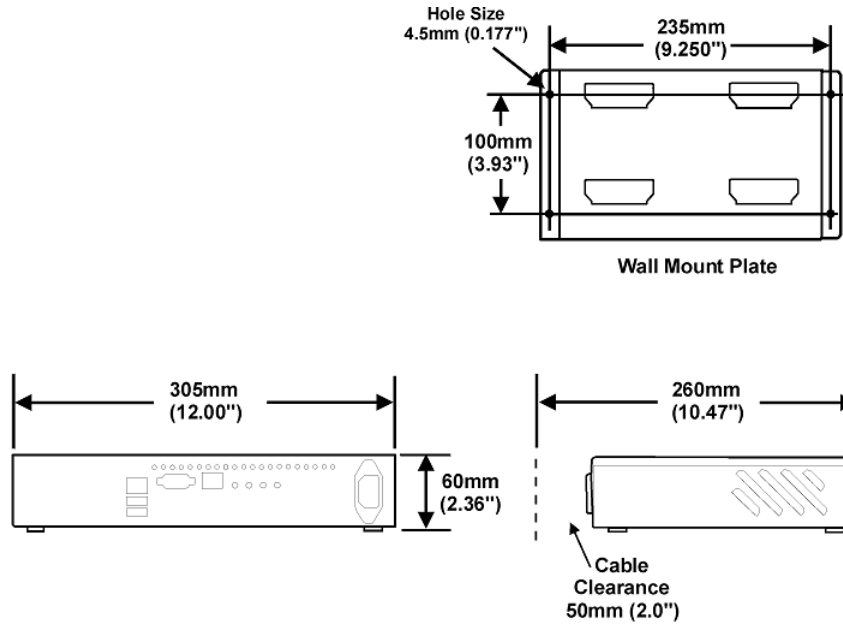

Order Confirmation System Remote Display Pedestal - Basic Dimensions

Figure 32-42 Order Confirmation System Remote Display Pedestal - Basic Dimensions

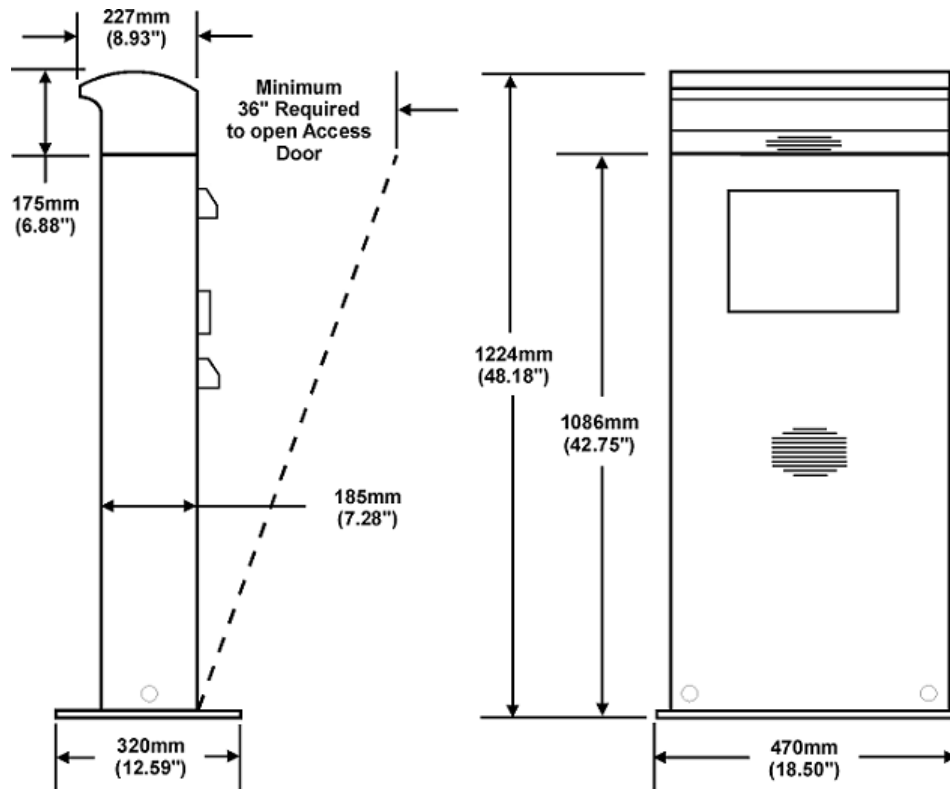

Order Confirmation System Remote Display Pedestal - Detail 1 Dimensions

Figure 32-43 Order Confirmation System Remote Display Pedestal - Detail 1 Dimensions

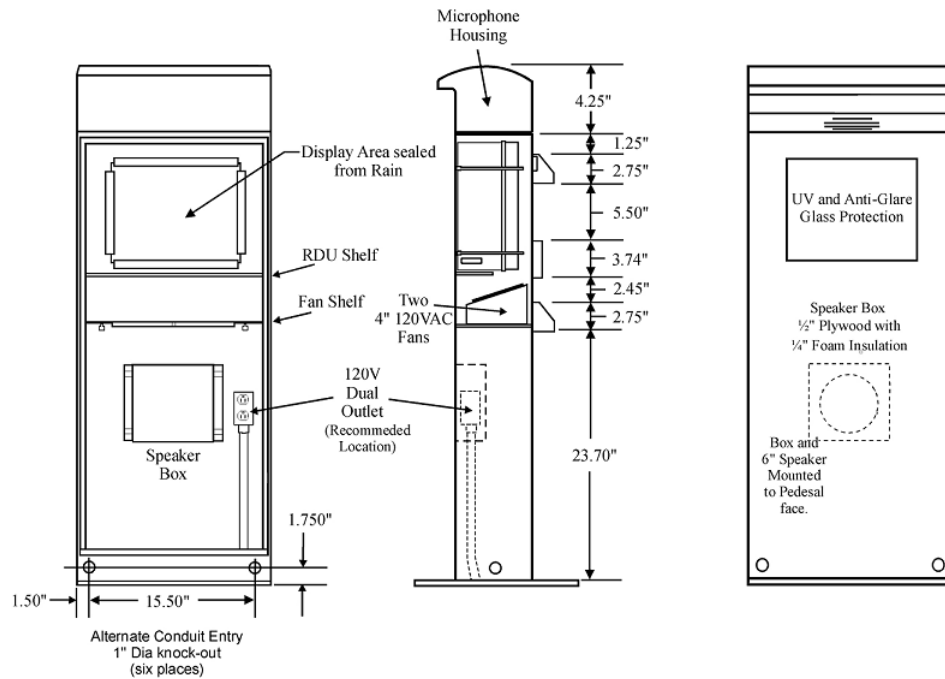

Order Confirmation System Remote Display Pedestal - Detail 2 Dimensions

Figure 32-44 Order Confirmation System Remote Display Pedestal - Detail 2 Dimensions

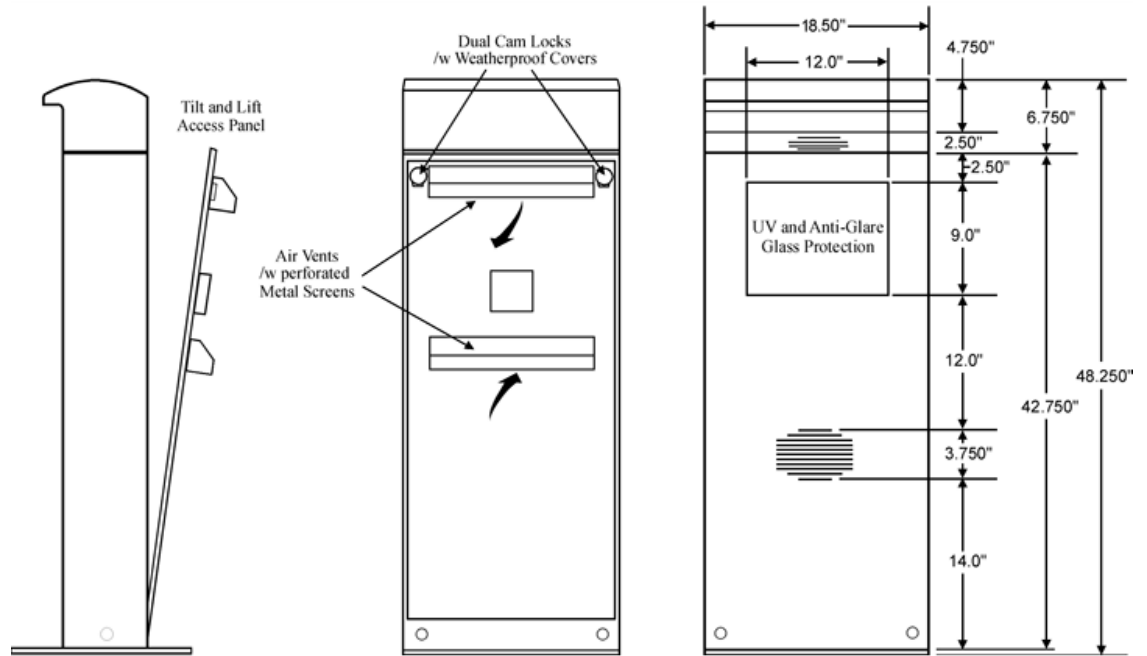

Order Confirmation System Remote Display Pedestal Baseplate Dimensions

Figure 32-45 Order Confirmation System Remote Display Pedestal Baseplate Dimensions

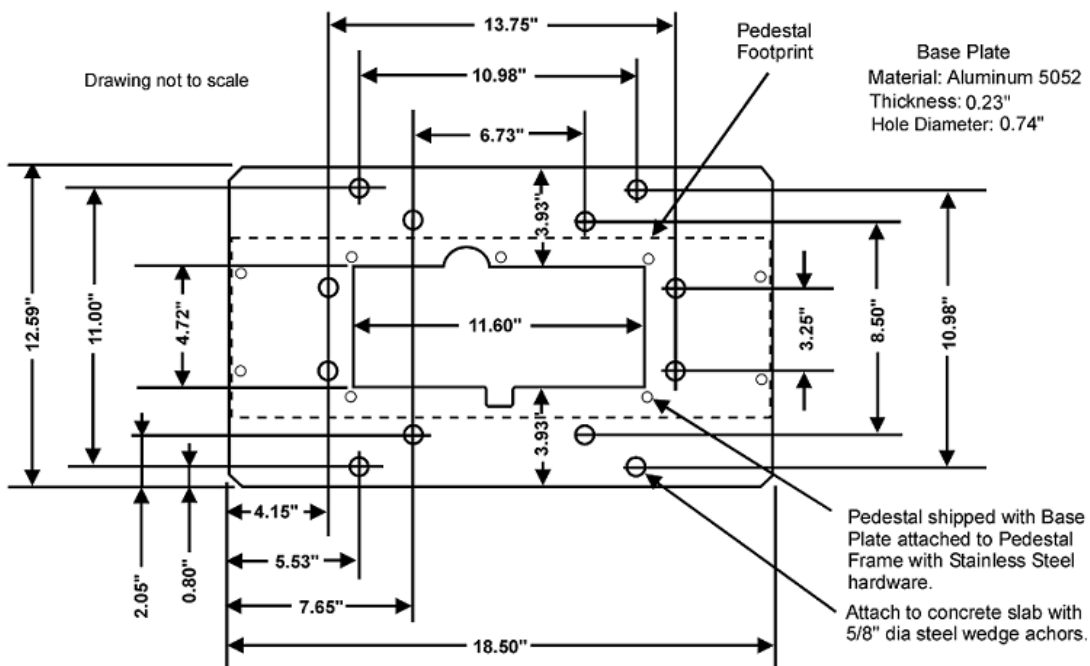

MICROS 10-Key Bumpbar Mounting Bracket Dimensions

Figure 32-46 10-Key Bumpbar Mounting Bracket Dimensions

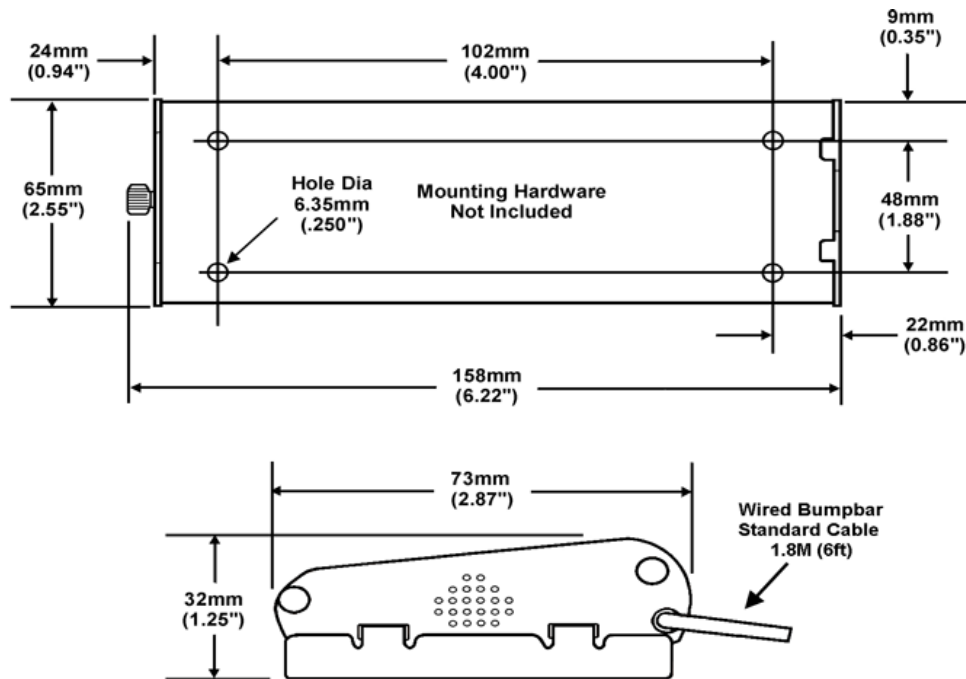

MICROS 20-Key Bumpbar Mounting Bracket Dimensions

Figure 32-47 20-Key Bumpbar Mounting Bracket Dimensions

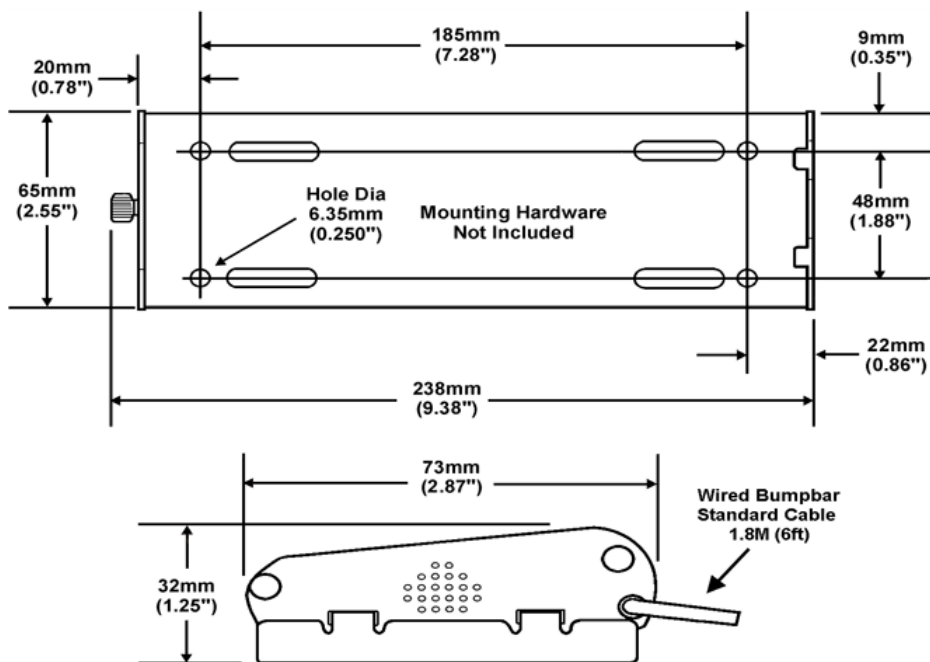

TM-T88 Thermal Roll Printer Dimensions

Figure 32-48 TM-T88 Thermal Roll Printer Dimensions

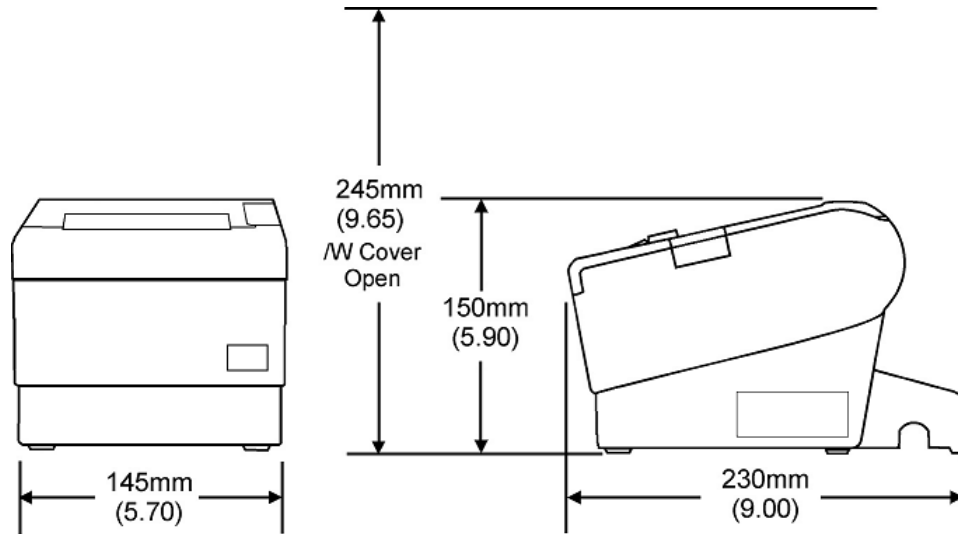

U200D Roll Printer Dimensions

Figure 32-49 U200D Roll Printer Dimensions

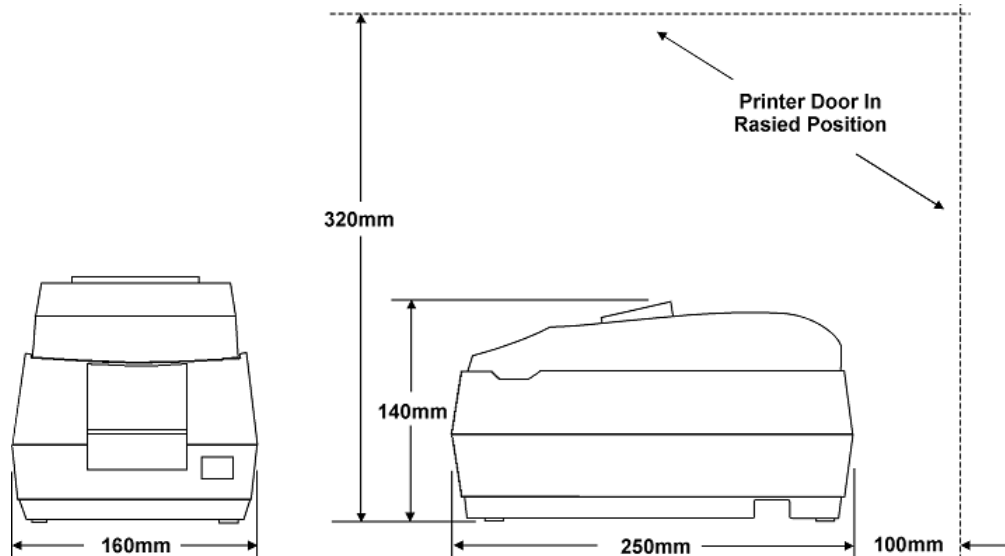

U220 Auto-Cut Roll Printer Dimensions

Figure 32-50 U220 Auto-Cut Roll Printer Dimensions

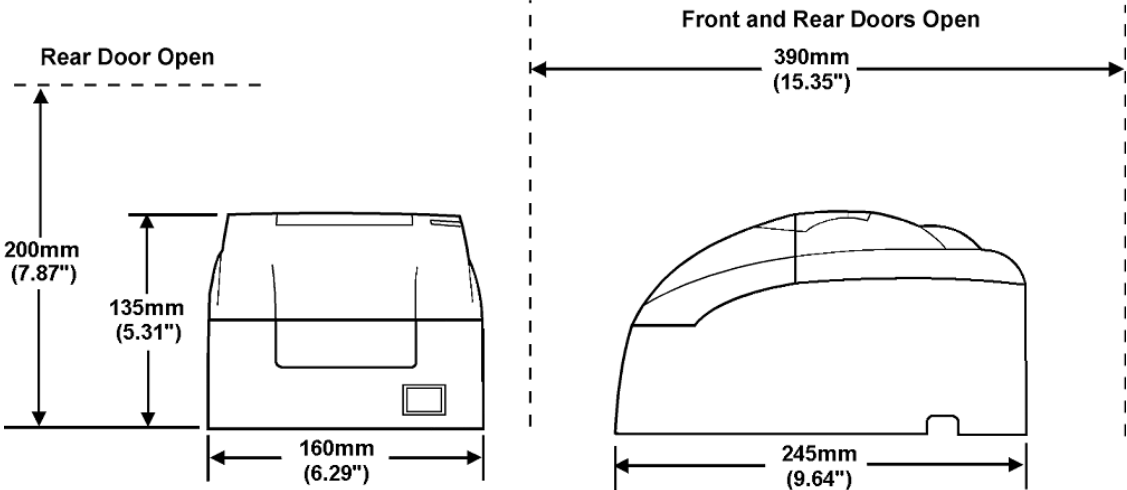

U200B Auto-Cut Roll Printer Dimensions

Figure 32-51 U200B Auto-Cut Roll Printer Dimensions

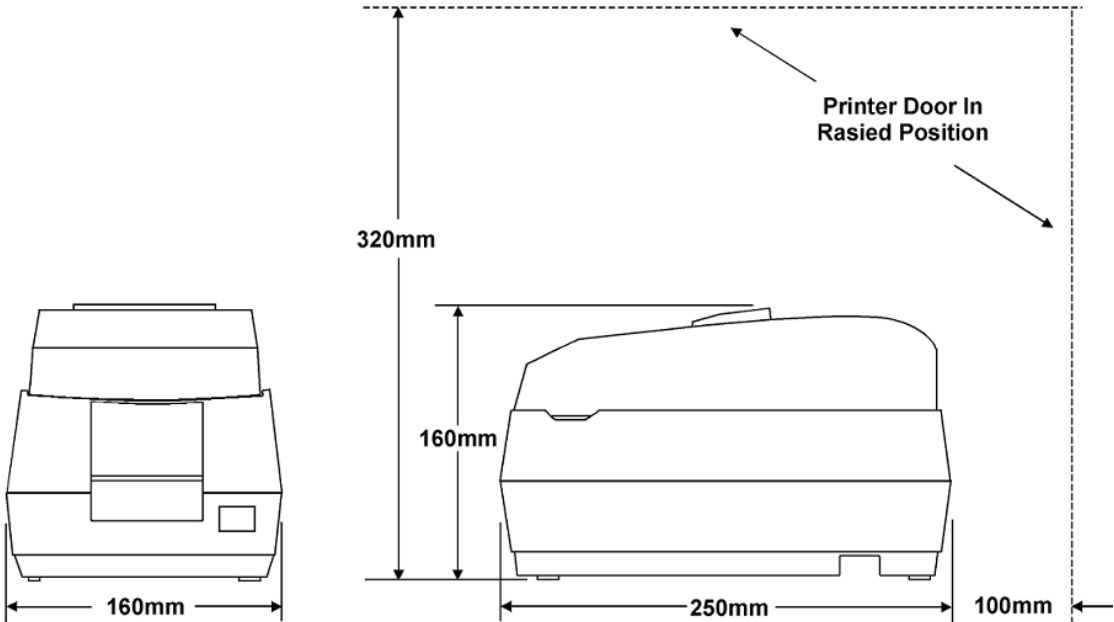

U230 Auto-Cut Roll Printer Dimensions

Figure 32-52 U230 Auto-Cut Roll Printer Dimensions

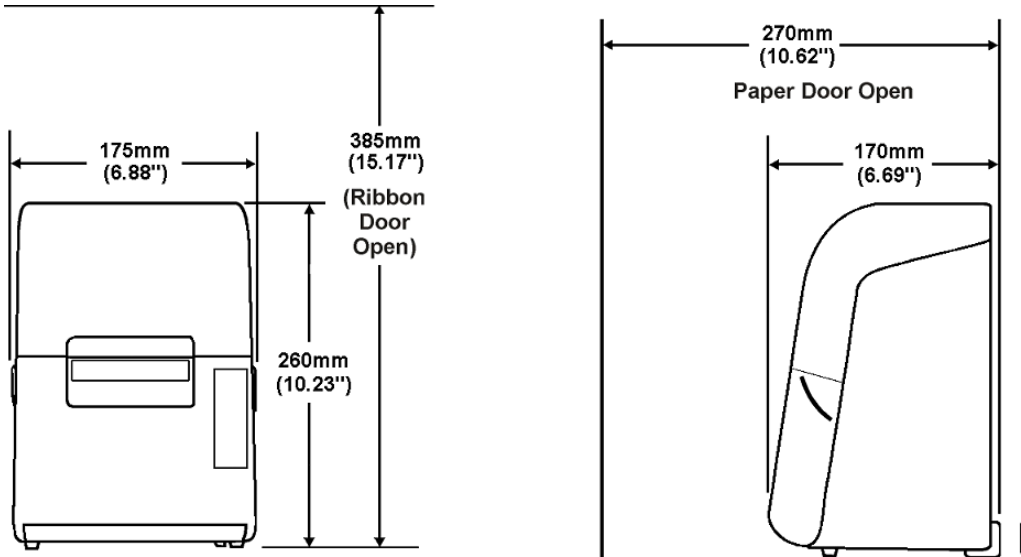

Pole Mount (6 inch) Protégé Customer Display Dimensions

Figure 32-53 Pole Mount (6 inch) Protégé Customer Display Dimensions

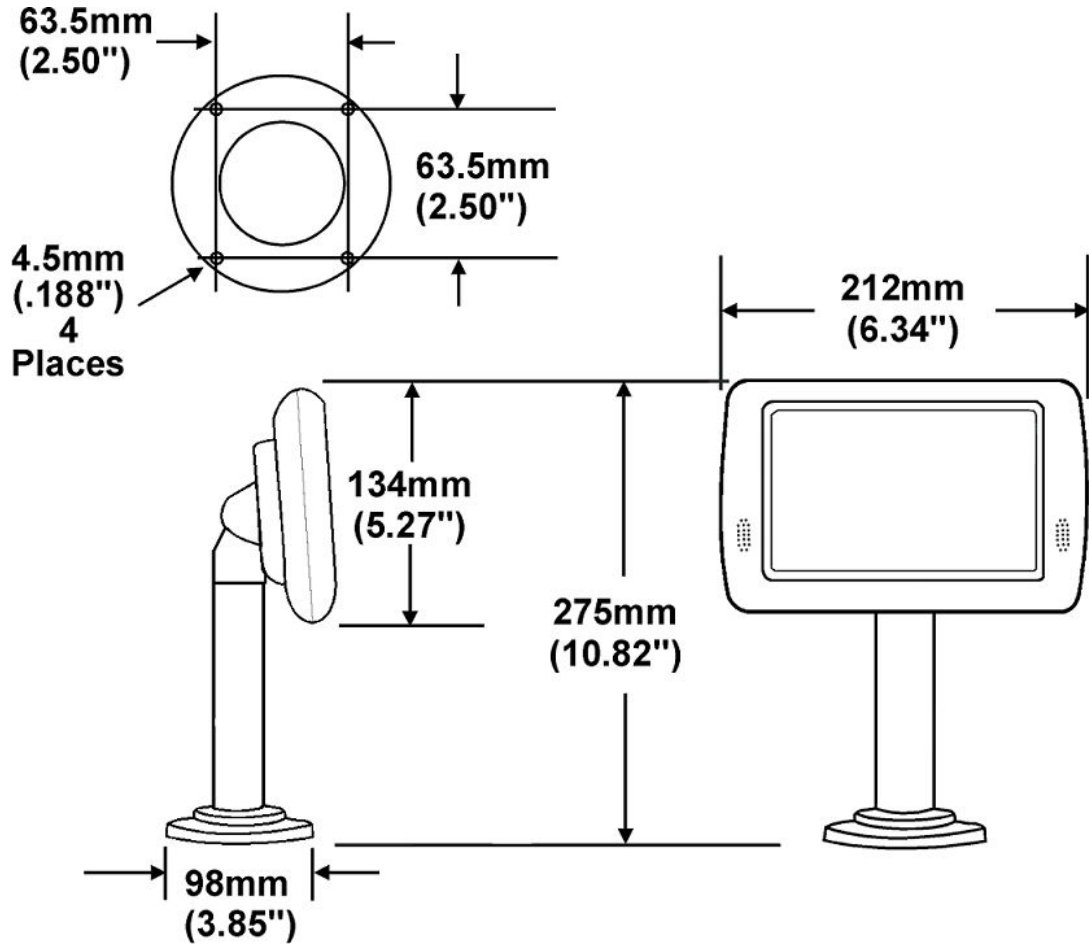

Series 1 Pole Customer Display Dimensions

Figure 32-54 Series 1 Pole Customer Display Dimensions

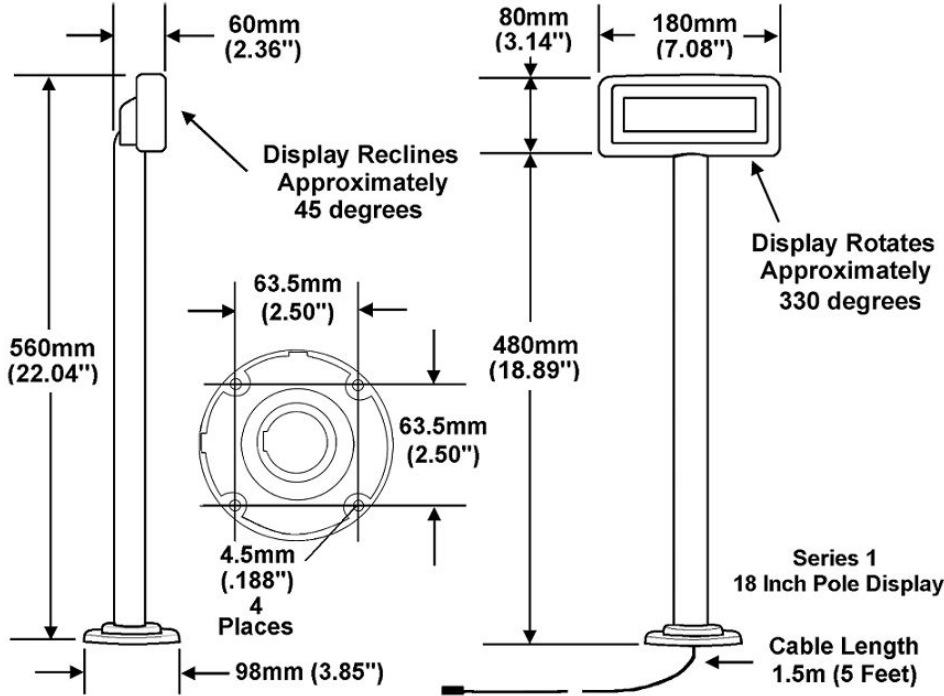

Series 2 Pole Customer Display Dimensions

Figure 32-55 Series 2 Pole Customer Display Dimensions

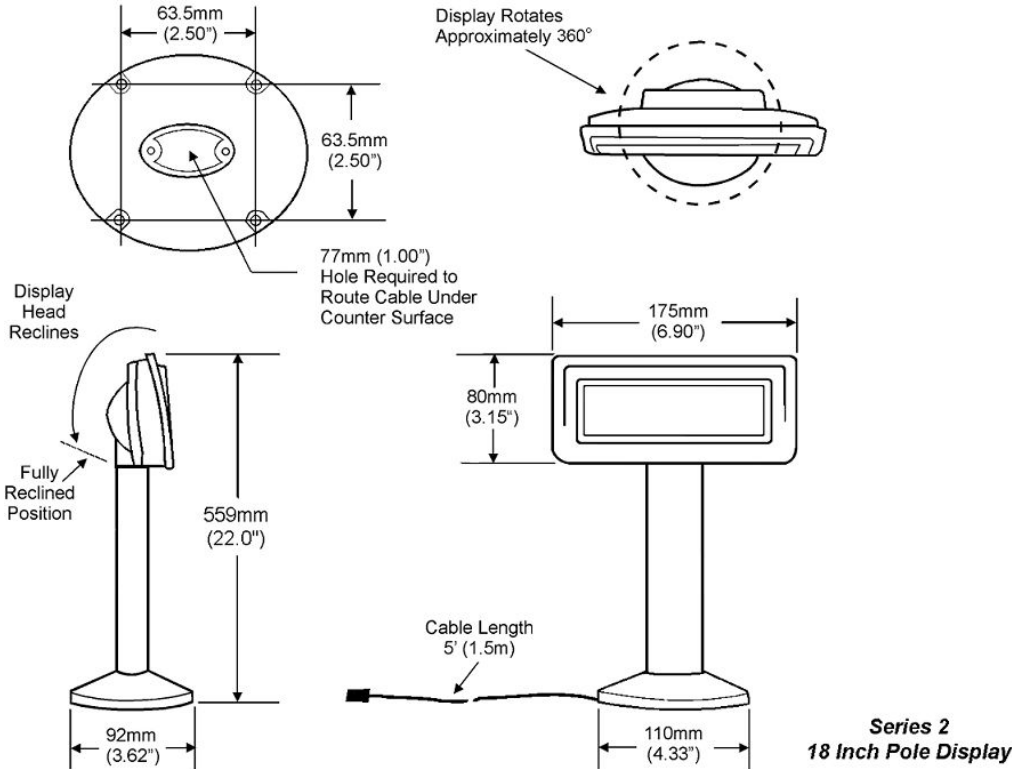

Cash Drawer Dimensions

Figure 32-56 Cash Drawer Dimensions

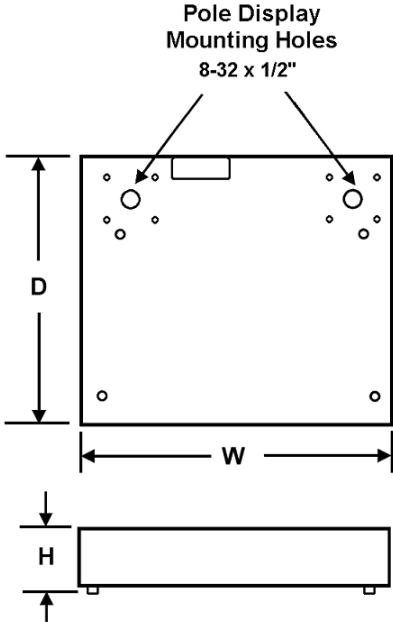

Part Number	W	D	H
400018-017-PT	16.0 inches 406.4 mm	16.7 inches 424.18 mm	5.0 inches 127.0 mm
400018-026-PT	18.0 inches 457.2 mm	16.7 inches 424.18 mm	4.2 inches 106.68 mm
400018-031-PT	18.0 inches 457.2 mm	16 inches 406.4 mm	4.2 inches 106.68 mm
400018-033-PT	13.3 inches 337.82 mm	17.2 inches 436.88 mm	4.2 inches 106.68 mm
400018-034-PT	18.0 inches 457.2 mm	16.7 inches 424.18 mm	4.2 inches 106.68 mm
400018-036-PT	18.0 inches 457.2 mm	16.7 inches 424.18 mm	4.2 inches 106.68 mm
400018-037-PT	16.0 inches 406.4 mm	16.7 inches 424.18 mm	5.0 inches 127.0 mm
400018-226-PT	18.0 inches 457.2 mm	16.7 inches 424.18 mm	4.2 inches 106.68 mm
400018-233-PT	13.3 inches 337.82 mm	17.2 inches 436.88 mm	4.2 inches 106.68 mm

Connectors

The following connectors are located on the IO Panel of the Workstations, except where noted.

To see more information about each Oracle MICROS Workstation, refer to the following Setup Guides:

- Workstation 4 LX Setup Guide
- Workstation 5A Setup Guide
- PC Workstation 2015 Setup Guide
- Order Confirmation System Setup Guide
- MICROS Tablet R-Series Setup Guide
- Workstation 6 Series Setup Guide

RS422-A, RS422-B or IDN

Over time two labels have been used to denote this multifunction Serial Port.

Workstations such as the WS 4 LX and KW270 include two ports labeled RS422-A and RS422-B. Later workstations including the WS 6, WS 5A, PCWS 2015, and Base Station include a single RS422 port labeled 'IDN'.

The IDN (COM4) and RS422-A/RS422-B (COM4 and COM5) ports are functionally equivalent, and default to RS422 mode in order to drive MICROS IDN printers. The figure below shows the pin-out of the RS422 configuration. The POS application can convert this port to a simple two-wire RS232 interface for driving serial peripherals.

Port Configured for driving RS422 IDN Devices – IDN (+)

The figure below shows the pin configuration of this port when driving IDN devices.

Figure 33-1 IDN or RS422-A/B Connectors Configured for IDN Printing

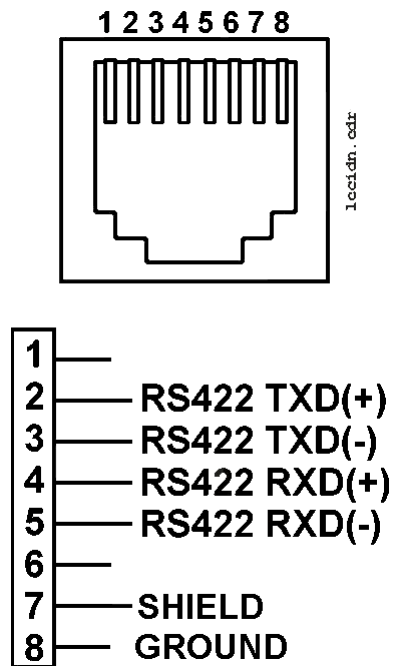

Port Configured for RS232 Devices

The figure below shows the multifunction modular port(s) configured as a basic RS232 Interface.

Figure 33-2 IDN or RS422-A/B Connectors Configured for RS232

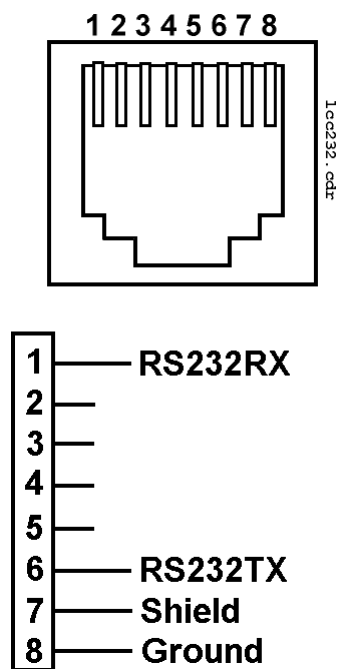

Modular RS232 COM or Powered RJ45 Port Diagram

The figure below shows a pin-out of the full featured RJ45 port available on the Workstation 6, PCWS 2015, Workstation 5A, KW270, and Base Station.

Figure 33-3 Modular COM Port with Handshaking

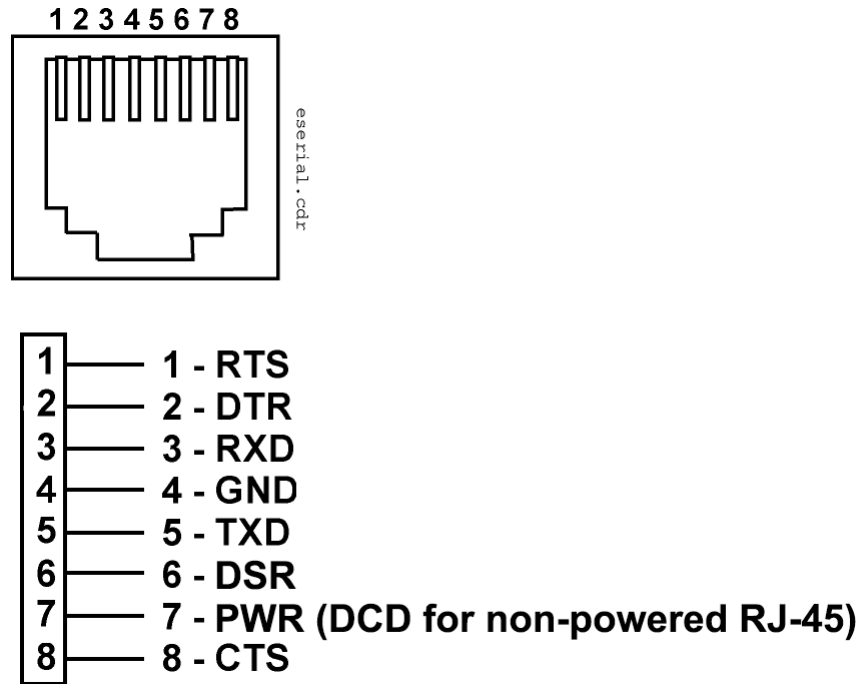

RS232 DB9 Connector

One DB9 RS232 connector, configured as COM1, is present on all current and legacy MICROS Workstations. For some, the port voltage is selected in the BIOS. In others, it is selected by the Diagnostics Utility.

Refer to the appropriate workstation setup guide for more details about powered DB9 COM ports.

The figure below shows the non-powered connector pin outs on the left and the powered connector pin outs on the right. The selected voltage, DSUB PWR, appears on Pin-9, the Ring Indicator. The selected voltage is applied to Pin 9, the Ring Indicator signal.

Figure 33-4 RS232 DB9 Connector

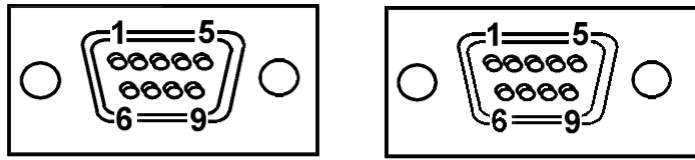

- 1 - DCD
- 2 - RXD
- 3 - TXD
- 4 - DTR
- 5 - GND
- 6 - DSR
- 7 - RTS
- 8 - CTS
- 9 - RI

- 1 - DCD
- 2 - RXD
- 3 - TXD
- 4 - DTR
- 5 - GND
- 6 - DSR
- 7 - RTS
- 8 - CTS
- 9 - DSUB PWR

Cash Drawer 1 and 2 Connectors

All MICROS Workstations contain a pair of the connectors shown in the figure below.

Figure 33-5 MICROS 4-Pin DIN Cash Drawer Connectors

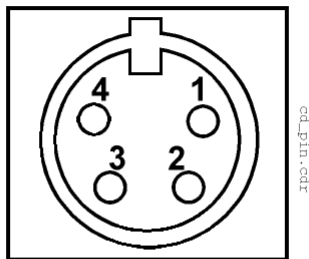

- 1 — +12V
- 2 — DRAWER OPEN
- 3 — GND
- 4 — DRAWER CLOSED

The Series 2 Cash Drawer connector is an 8-pin Mini-IDN. This pair of Cash Drawer connectors is used by the Workstation 6 and the Base Station.

Figure 33-6 8-Pin Mini-DIN (Series 2) Cash Drawer Connector

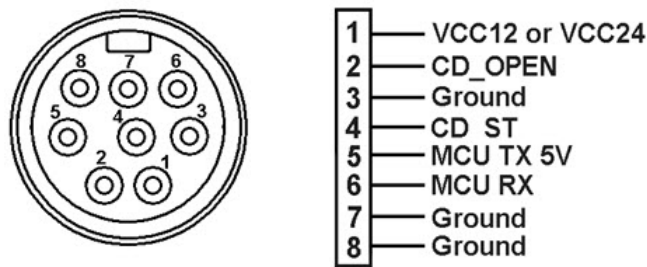

The following table describes the signal name and function of each pin:

Table 33-1 Series 2 Cash Drawer Pin and Signal Reference

Pin #	Signal name	Description
1	VCC12 or VCC24	Cash Drawer power
2	CD_OPEN	Open drawer
3,7,8	Ground	Signal grounds
4	CD_ST	Input status from cash drawer
5	MCU_TX_5V	Tx data to Cash Drawer
6	MCURX	Rx data from Cash Drawer

Pole Customer Display Connector

The Pole Customer Display port is located on virtually all Workstations including the WS 4 LX, KW270, WS 5A, WS 6, PCWS 2015, and the Base Station.

Figure 33-7 Remote Customer Display Connector Diagram

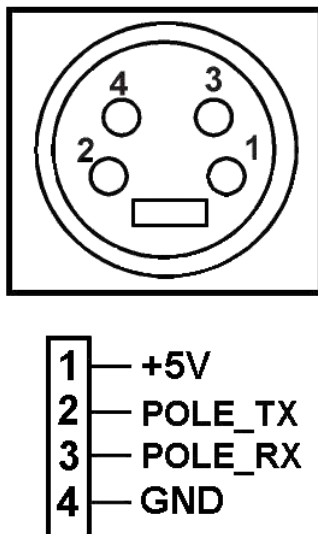

34

Hook-Up Cables

The following pages include assorted diagrams of optional hook-up cables that are used on most MICROS Workstations.

Null Modem Cable for e7 KVM Controller

The figure below shows a Null Modem Cable that is used for the e7 KVM Controller serial interface.

Figure 34-1 Null Modem Cable Pin-Outs

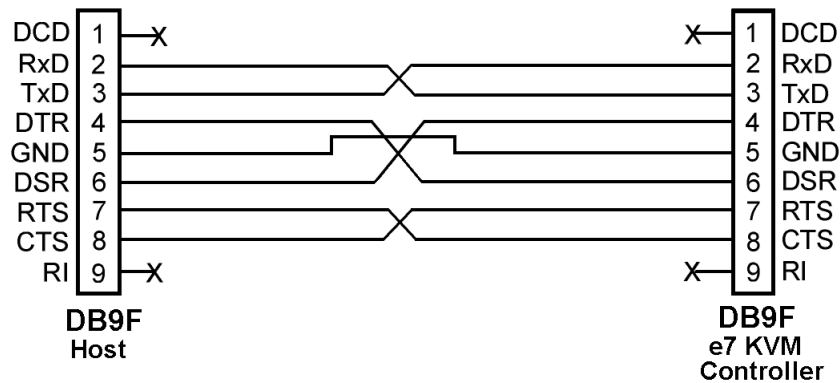

IDN Port Conversion Cables

The figure below shows a diagram of adapter cable PN 300319-102-PT. This cable converts the RJ45 IDN or RS422-A/RS422-B ports shown in the figure below to a DB9 Male connector.

Figure 34-2 Modular LCC/RS232 to DB9 Male Connector

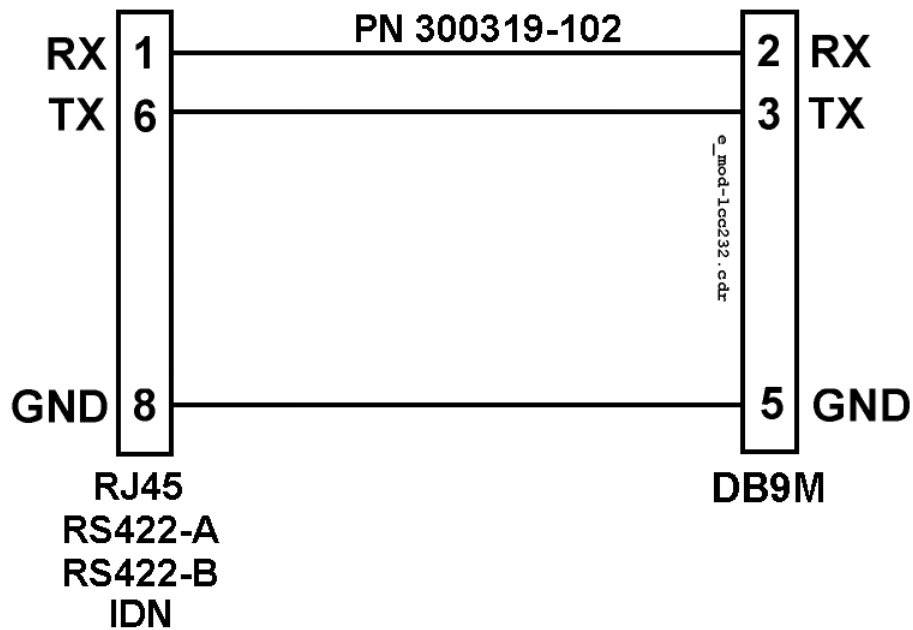

The figure below shows a diagram of a similar cable that terminates with a DB25 Male connector in place of the DB9.

Figure 34-3 Modular LCC/RS232 to DB25 Connector

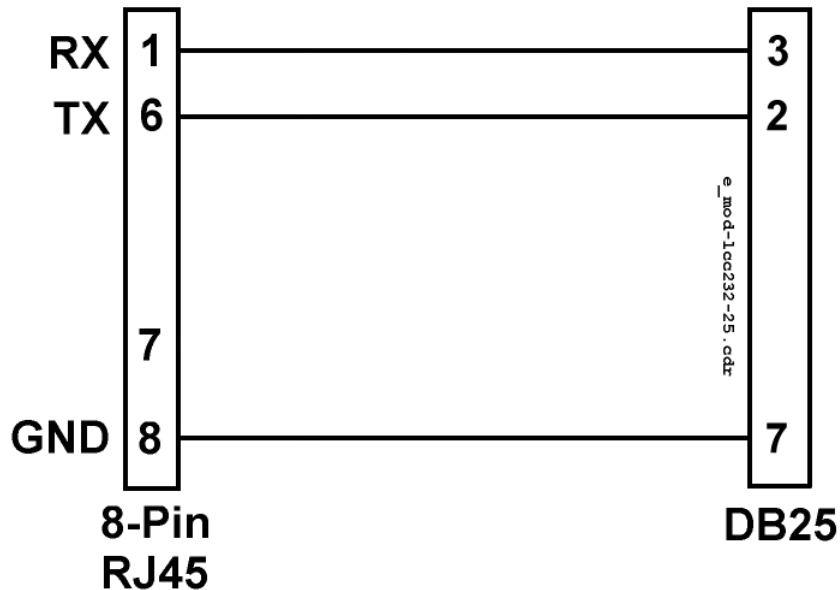

Modular RS232 Port to DB9/DB25 Male Connector

The figure below shows a diagram of cable PN 300319-103-PT. This cable converts a modular COM 2 or COM 5 port to a DB9 Male connector.

Figure 34-4 Modular RS232 Port to DB9 Male Connector

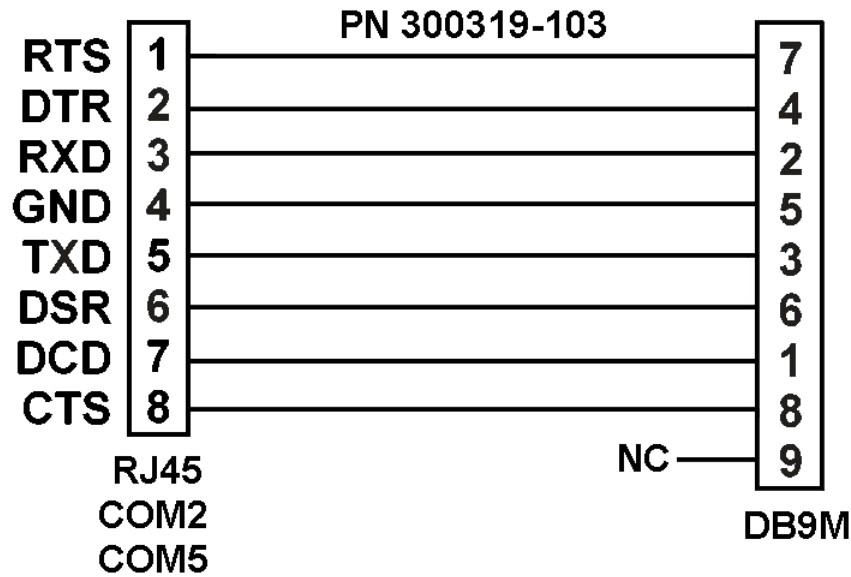

The figure below shows a diagram of a similar cable that terminates in a DB25 Male connector.

Figure 34-5 Modular RS232 Port to DB25 Male Connector

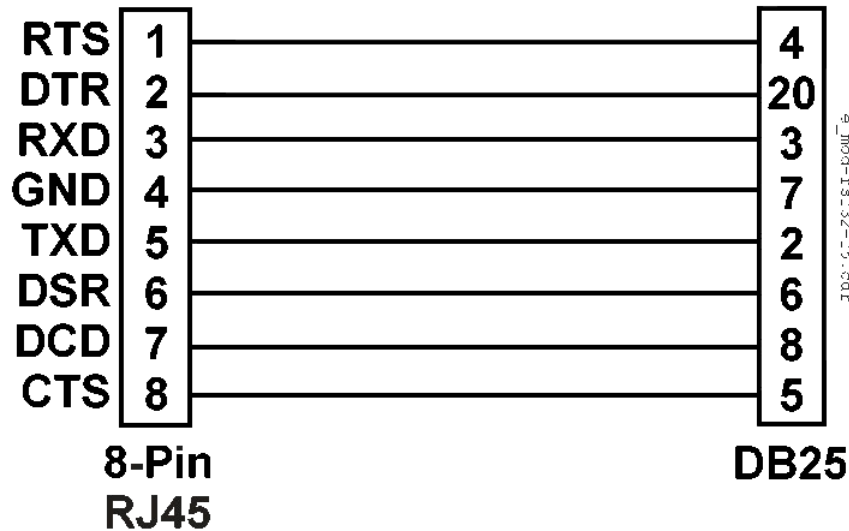

8-Pin to 6-Pin Hook-up RS422 Cable

The figure below shows a diagram of the patch cable connected between a workstation IDN or RS422-A/RS422-B port to a printer IDN port or 6-pin modular jack on a wall plate.

Figure 34-6 Workstation to Printer IDN Hook-up Cable Diagram

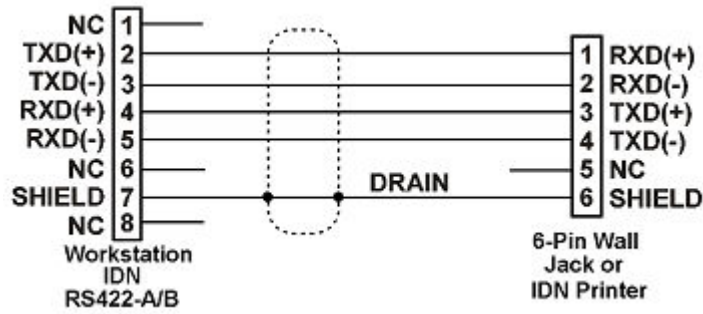

IDN to EIA/TIA-568-A Patch Cable

The figure below shows a diagram of the patch cable used to build an IDN network using STP Category 5 or better cabling. The [Cable Requirements](#) section contains more information.

Figure 34-7 IDN to EIA/TIA-568-A Conversion Cable Diagram

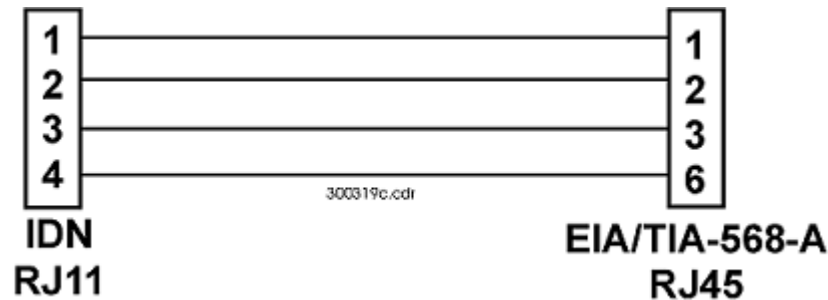

FCC/DOC Statement

The following sections contain related statements as required by the United States and Canada:

Federal Communications Commission Radio Frequency Interference Statement

This equipment generates, uses, and can radiate radio frequency energy, and if not installed and used in accordance with the instruction manual, may cause interference to radio communications. It has been tested and found to comply with the limits for a Class A computing device pursuant to Subpart J of Part 15 of FCC Rules, which are designed to provide reasonable protection against such interference when operated in a commercial environment. Operation of this equipment in a residential area is likely to cause interference in equipment, in which case the user at his own expense will be required to take whatever measures may be required to correct the interference.

If this equipment appears to cause interference the user could consult the installer/dealer or an experienced radio television technician.

A booklet prepared by the Federal Communications Commission entitled "How to Identify and Resolve Radio - TV Interference Problems" may be useful. This booklet may be ordered from the Superintendent of Documents, U.S. Government Printing Office, Washington D.C. with stock number #004-000-00345-4.

CAUTION: Changes or modifications not expressly approved by the party responsible for compliance could void the user's authority to operate the equipment. Shielded interface cables must be used in order to comply with the emission limits.

Canadian Department of Communications Statement

This digital apparatus does not exceed the Class A/Class B (whichever applies) limits for radio noise emissions from digital apparatus as set out in the Radio Interference Regulations of the Canadian Department of Communications.

Le présent appareil numérique n'émet pas de bruits radioélectriques dépassant les limites applicables aux appareils numériques de Classe A/de Classe B (selon le cas) prescrites dans Le Règlement sur le Brouillage Radioélectrique Idicté par le Ministère des Communications du Canada.

ATTENTION: Tous changement ou modification, non expressément agrées par la partie responsable pour la conformité de l'installation, pourraient annuler l'autorisation de l'exploitation par l'utilisateur du materiel installé. Il est obligatoire d'utiliser pour la communication ou la réalisation d'intorfaces un cable blindé, afin d'être en conformité avec les limites légales d'émission.