

**Oracle® Fusion Middleware**

Adapter for Oracle Applications User's Guide

11g Release 1 (11.1.1.7.0)

**Part No. E10537-05**

February 2013

Oracle Fusion Middleware Adapter for Oracle Applications User's Guide, 11g Release 1 (11.1.1.7.0)

Part No. E10537-05

Copyright © 2005, 2013, Oracle and/or its affiliates. All rights reserved.

Primary Author: Melody Yang

Contributing Author: Santiago Bastidas, Sravani Bheemireddy, Vimmika Dinesh, Rajesh Ghosh, Anil Kemisetti, Satish Menedi, Nadakuditi Ravindra, Veshaal Singh, Sheela Vasudevan

Oracle and Java are registered trademarks of Oracle and/or its affiliates. Other names may be trademarks of their respective owners.

Intel and Intel Xeon are trademarks or registered trademarks of Intel Corporation. All SPARC trademarks are used under license and are trademarks or registered trademarks of SPARC International, Inc. AMD, Opteron, the AMD logo, and the AMD Opteron logo are trademarks or registered trademarks of Advanced Micro Devices. UNIX is a registered trademark of The Open Group.

This software and related documentation are provided under a license agreement containing restrictions on use and disclosure and are protected by intellectual property laws. Except as expressly permitted in your license agreement or allowed by law, you may not use, copy, reproduce, translate, broadcast, modify, license, transmit, distribute, exhibit, perform, publish, or display any part, in any form, or by any means. Reverse engineering, disassembly, or decompilation of this software, unless required by law for interoperability, is prohibited.

The information contained herein is subject to change without notice and is not warranted to be error-free. If you find any errors, please report them to us in writing.

If this is software or related documentation that is delivered to the U.S. Government or anyone licensing it on behalf of the U.S. Government, the following notice is applicable:

U.S. GOVERNMENT END USERS: Oracle programs, including any operating system, integrated software, any programs installed on the hardware, and/or documentation, delivered to U.S. Government end users are "commercial computer software" pursuant to the applicable Federal Acquisition Regulation and agency-specific supplemental regulations. As such, use, duplication, disclosure, modification, and adaptation of the programs, including any operating system, integrated software, any programs installed on the hardware, and/or documentation, shall be subject to license terms and license restrictions applicable to the programs. No other rights are granted to the U.S. Government.

This software or hardware is developed for general use in a variety of information management applications. It is not developed or intended for use in any inherently dangerous applications, including applications that may create a risk of personal injury. If you use this software or hardware in dangerous applications, then you shall be responsible to take all appropriate fail-safe, backup, redundancy, and other measures to ensure its safe use. Oracle Corporation and its affiliates disclaim any liability for any damages caused by use of this software or hardware in dangerous applications.

This software or hardware and documentation may provide access to or information on content, products, and services from third parties. Oracle Corporation and its affiliates are not responsible for and expressly disclaim all warranties of any kind with respect to third-party content, products, and services. Oracle Corporation and its affiliates will not be responsible for any loss, costs, or damages incurred due to your access to or use of third-party content, products, or services.

---

# Contents

## Send Us Your Comments

## Preface

### 1 What's New in This Guide for Release 11.1.1.7

What's New in This Guide.....	1-1
-------------------------------	-----

### 2 Introduction to Adapter for Oracle Applications

Overview of Adapter for Oracle Applications.....	2-1
Integration with Oracle Fusion Middleware.....	2-4
Integration with Oracle WebLogic Server.....	2-6

### 3 Adapter for Oracle Applications Features

Overview.....	3-1
Support for Various Integration Interface Types.....	3-1
Support for Oracle Integration Repository.....	3-3
Support for Custom Integration Interfaces in Various Versions of Oracle E-Business Suite .....	3-4
High Availability.....	3-7

### 4 Adapter for Oracle Applications Concepts

Overview.....	4-1
Understanding Applications Context .....	4-1
Support for Normalized Message Properties.....	4-7
Support for Multiple Organization Access Control (MOAC).....	4-11
Support for Multiple Languages.....	4-12

<b>Understanding Adapter for Oracle Applications Security</b> .....	4-14
<b>Flexfield Support for PL/SQL APIs</b> .....	4-21
Understanding Key Elements in Flexfield Configuration.....	4-23
Accessing Flexfield Configuration User Interface.....	4-27
Adding or Configuring a New Mapping.....	4-29
Configuring Key Flexfields.....	4-31
Configuring Descriptive Flexfields.....	4-52
Importing an Existing Flexfield Mapping.....	4-73
Modifying Flexfield Definitions.....	4-77
Reviewing Flexfield Configurations.....	4-80
<b>Logging</b> .....	4-81
<b>Enhanced Error and Exception Handling</b> .....	4-96
Handling Functional Errors.....	4-97
<b>Secured Connection Between Oracle E-Business Suite and Oracle Fusion Middleware SOA Suite Using J2EE Data Source Implementation</b> .....	4-97
<b>Understanding the Oracle Applications Module Browser</b> .....	4-98

## 5 Using XML Gateway

<b>Overview of XML Gateway</b> .....	5-2
<b>Design-Time Tasks for XML Gateway Inbound Messaging</b> .....	5-6
<b>Creating a New SOA Composite Application with BPEL Process</b> .....	5-8
<b>Creating a Partner Link</b> .....	5-12
<b>Adding a Partner Link for the File Adapter</b> .....	5-22
<b>Configuring the Invoke Activities</b> .....	5-26
<b>Configuring the Assign Activity</b> .....	5-33
<b>Run-Time Tasks for XML Gateway Inbound Messaging</b> .....	5-36
<b>Deploying the SOA Composite Application with BPEL Process</b> .....	5-36
<b>Testing the SOA Composite with BPEL Process</b> .....	5-41
<b>Verifying Records in Oracle E-Business Suite</b> .....	5-43
<b>Design-Time Task for XML Gateway Outbound Messaging</b> .....	5-47
<b>Creating a SOA Composite Application with BPEL Process</b> .....	5-50
<b>Adding a Partner Link</b> .....	5-54
<b>Adding a Receive Activity</b> .....	5-59
<b>Adding a Partner Link for File Adapter</b> .....	5-61
<b>Adding an Invoke Activity</b> .....	5-65
<b>Adding an Assign Activity</b> .....	5-67
<b>Run-Time Task for XML Gateway Outbound Messaging</b> .....	5-69
<b>Deploying the SOA Composite Application with BPEL Process</b> .....	5-70
<b>Testing the SOA Composite Application with BPEL Process</b> .....	5-74
<b>Troubleshooting</b> .....	5-79



## 6 Using Business Events

Overview of Business Events.....	6-1
Business Events Concepts.....	6-2
Business Event Groups.....	6-3
Design-Time Tasks for Outbound Business Events.....	6-4
Creating a New SOA Composite Application with BPEL Process.....	6-6
Creating a Partner Link.....	6-10
Configuring the Receive Activity.....	6-21
Adding a Partner Link for the File Adapter.....	6-23
Configuring an Invoke Activity.....	6-30
Configuring an Assign Activity.....	6-32
Run-Time Tasks for Outbound Business Events.....	6-35
Deploying the SOA Composite Application with BPEL Process.....	6-36
Testing the SOA Composite Application with BPEL Process.....	6-39
Troubleshooting .....	6-47

## 7 Using Concurrent Programs

Overview of Concurrent Programs.....	7-1
Design-Time Tasks for Concurrent Programs.....	7-3
Creating a New SOA Composite Application with BPEL Project.....	7-4
Adding Partner Links.....	7-9
Adding Partner Links for File Adapter.....	7-31
Configuring Invoke Activities.....	7-42
Configuring Assign Activities.....	7-49
Run-Time Tasks for Concurrent Programs.....	7-54
Deploying the SOA Composite Application with BPEL Process.....	7-54
Testing the Deployed SOA Composite Application with BPEL Process.....	7-59
Verifying Records in Oracle E-Business Suite.....	7-62
Troubleshooting.....	7-63

## 8 Using Interface Tables and Views

Overview of Interface Tables and Views.....	8-2
Design-Time Tasks for Interface Tables.....	8-3
Creating a New SOA Composite Application with BPEL Process.....	8-3
Adding a Partner Link.....	8-7
Adding a Partner Link for File Adapter.....	8-23
Configuring Invoke Activities.....	8-27
Configuring an Assign Activity.....	8-30
Run-Time Tasks for Interface Tables.....	8-32

Deploying the SOA Composite Application with BPEL Process.....	8-33
Testing the Deployed SOA Composite Application with BPEL Process.....	8-36
Design-Time Tasks for Views.....	8-39
Creating a New SOA Composite Application with BPEL Process.....	8-40
Adding a Partner Link.....	8-45
Adding a Partner Link for File Adapter.....	8-59
Configuring Invoke Activities.....	8-65
Configuring an Assign Activity.....	8-69
Run-Time Tasks for Views.....	8-72
Deploying the SOA Composite Application with BPEL Process.....	8-72
Testing the Deployed SOA Composite Application with BPEL Process.....	8-77

## 9 Using PL/SQL APIs

Overview of PL/SQL APIs.....	9-1
Design-Time Tasks for PL/SQL APIs.....	9-2
Creating a New SOA Composite Application with BPEL Process.....	9-4
Adding Partner Links.....	9-8
Adding a Partner Link for File Adapter.....	9-20
Defining Wrapper APIs.....	9-26
Declaring Parameters with a DEFAULT Clause.....	9-29
Configuring the Invoke Activities.....	9-32
Configuring a Transform Activity.....	9-36
Configuring an Assign Activity.....	9-39
Run-Time Tasks for PL/SQL APIs.....	9-44
Deploying the SOA Composite Application with BPEL Process.....	9-44
Testing the Deployed SOA Composite Application with BPEL Process.....	9-49
Troubleshooting.....	9-53

## 10 Using e-Commerce Gateway

Overview of e-Commerce Gateway Integration.....	10-1
Design-Time Tasks for e-Commerce Gateway.....	10-2
Creating a New SOA Composite Application with BPEL Process.....	10-3
Adding a Partner Link.....	10-8
Adding a Partner Link for File Adapter.....	10-15
Configuring Invoke Activities.....	10-20
Configuring an Assign Activity.....	10-25
Run-Time Tasks for e-Commerce Gateway.....	10-28
Deploying the SOA Composite Application with BPEL Process.....	10-28
Testing the Deployed SOA Composite Application with BPEL Process.....	10-33
Verifying Records in Oracle E-Business Suite.....	10-36

**A WSDL Definition File and Connection Information Details**

WSDL Definition File..... A-1  
Configuring Connection Information..... A-2

**B Troubleshooting and Workarounds**

General Issues and Workarounds..... B-1

**C Adapter for Oracle Applications Properties**

Overview..... C-1

**Index**



---

# Send Us Your Comments

**Oracle Fusion Middleware Adapter for Oracle Applications User's Guide, 11g Release 1 (11.1.1.7.0)  
Part No. E10537-05**

Oracle welcomes customers' comments and suggestions on the quality and usefulness of this document. Your feedback is important, and helps us to best meet your needs as a user of our products. For example:

- Are the implementation steps correct and complete?
- Did you understand the context of the procedures?
- Did you find any errors in the information?
- Does the structure of the information help you with your tasks?
- Do you need different information or graphics? If so, where, and in what format?
- Are the examples correct? Do you need more examples?

If you find any errors or have any other suggestions for improvement, then please tell us your name, the name of the company who has licensed our products, the title and part number of the documentation and the chapter, section, and page number (if available).

Note: Before sending us your comments, you might like to check that you have the latest version of the document and if any concerns are already addressed. To do this, access the new Oracle E-Business Suite Release Online Documentation CD available on My Oracle Support and [www.oracle.com](http://www.oracle.com). It contains the most current Documentation Library plus all documents revised or released recently.

Send your comments to us using the electronic mail address: [appsdoc\\_us@oracle.com](mailto:appsdoc_us@oracle.com)

Please give your name, address, electronic mail address, and telephone number (optional).

If you need assistance with Oracle software, then please contact your support representative or Oracle Support Services.

If you require training or instruction in using Oracle software, then please contact your Oracle local office and inquire about our Oracle University offerings. A list of Oracle offices is available on our Web site at [www.oracle.com](http://www.oracle.com).



---

# Preface

## Intended Audience

Welcome to the *Oracle Fusion Middleware Adapter for Oracle Applications User's Guide*, 11g Release 1 (11.1.1.7.0)

This documentation is written for the technical consultants, implementers and system integration consultants who use Oracle Fusion Middleware Adapter for Oracle Applications.

This guide assumes you have a working knowledge of the following:

- The principles and customary practices of your business area.
- Oracle E-Business Suite.
- Oracle BPEL Process Manager.
- Oracle JDeveloper.
- Oracle Database, Oracle Fusion Middleware, Oracle WebLogic Server, and PL/SQL technology.
- Oracle E-Business Suite Integration Interfaces.
- Oracle integration technologies, including Web services, WSDL, XML Gateway, EDI Gateway, and the Business Event System.
- B2B, A2A and BP integrations.

If you have never used these products, Oracle suggests that you attend training classes available through Oracle University.

See Related Information Sources on page xii for more Oracle E-Business Suite product information.

## Documentation Accessibility

For information about Oracle's commitment to accessibility, visit the Oracle Accessibility Program website at <http://www.oracle.com/pls/topic/lookup?ctx=acc&id=docacc>.

## Access to Oracle Support

Oracle customers have access to electronic support through My Oracle Support. For information, visit <http://www.oracle.com/pls/topic/lookup?ctx=acc&id=info> or visit <http://www.oracle.com/pls/topic/lookup?ctx=acc&id=trs> if you are hearing impaired.

## Structure

- 1 What's New in This Guide for Release 11.1.1.7**
- 2 Introduction to Adapter for Oracle Applications**
- 3 Adapter for Oracle Applications Features**
- 4 Adapter for Oracle Applications Concepts**
- 5 Using XML Gateway**
- 6 Using Business Events**
- 7 Using Concurrent Programs**
- 8 Using Interface Tables and Views**
- 9 Using PL/SQL APIs**
- 10 Using e-Commerce Gateway**
- A WSDL Definition File and Connection Information Details**
- B Troubleshooting and Workarounds**
- C Adapter for Oracle Applications Properties**

## Related Information Sources

You can choose from many sources of information, including online documentation, training, and support services, to increase your knowledge and understanding of Oracle Fusion Middleware Adapter for Oracle Applications.

### Documentation

You may want to refer to other Oracle Fusion Middleware guides when you set up and use Oracle Fusion Middleware Adapter for Oracle Applications. You can read the guides online by reading from the Oracle Fusion Middleware or Oracle Database Documentation Library CD included in your media pack, or on the Oracle Technology Network (OTN).

To download free release notes, installation documentation, white papers, or other collateral, please visit the main OTN page.

### Training

Oracle offers a complete set of training courses to help you and your staff master Oracle



Fusion Middleware 11g and reach full productivity quickly. These courses are organized into functional learning paths, so you take only those courses appropriate to your job or area of responsibility.

You have a choice of educational environments. You can attend courses offered by Oracle University at any one of our many Education Centers, you can arrange for our trainers to teach at your facility, or you can use Oracle Learning Network (OLN), Oracle University's online education utility.

**Tip:** For information about upcoming instructor-led training, please refer to Oracle University's course offerings.

In addition, Oracle training professionals can tailor standard courses or develop custom courses to meet your needs. For example, you may want to use your organization's structure, terminology, and data as examples in a customized training session delivered at your own facility.

### **Support**

From on-site support to central support, our team of experienced professionals provides the help and information you need to keep Oracle Fusion Middleware 11g working for you. This team includes your Technical Representative, Account Manager, and Oracle's large staff of consultants and support specialists, with expertise in your business area, managing an Oracle Database, and your hardware and software environment.

## **Do Not Use Database Tools to Modify Oracle E-Business Suite Data**

Oracle **STRONGLY RECOMMENDS** that you never use SQL\*Plus, Oracle Data Browser, database triggers, or any other tool to modify Oracle E-Business Suite data unless otherwise instructed.

Oracle provides powerful tools you can use to create, store, change, retrieve, and maintain information in an Oracle database. But if you use Oracle tools such as SQL\*Plus to modify Oracle E-Business Suite data, you risk destroying the integrity of your data and you lose the ability to audit changes to your data.

Because Oracle E-Business Suite tables are interrelated, any change you make using an Oracle E-Business Suite form can update many tables at once. But when you modify Oracle E-Business Suite data using anything other than Oracle E-Business Suite, you may change a row in one table without making corresponding changes in related tables. If your tables get out of synchronization with each other, you risk retrieving erroneous information and you risk unpredictable results throughout Oracle E-Business Suite.

When you use Oracle E-Business Suite to modify your data, Oracle E-Business Suite automatically checks that your changes are valid. Oracle E-Business Suite also keeps track of who changes information. If you enter information into database tables using database tools, you may store invalid information. You also lose the ability to track who has changed your information because SQL\*Plus and other database tools do not keep a record of changes.



---

# What's New in This Guide for Release 11.1.1.7

## What's New in This Guide

For Release 11.1.1.7, this guide has been updated in several ways. The following table lists the sections that have been added or changed.

For a list of known issues (release notes), see the "Known Issues for Oracle SOA Products and Oracle AIA Foundation Pack" at

<http://www.oracle.com/technetwork/middleware/docs/soa-aiafp-knownissuesindex-364630.html>.

Sections	Changes Made	February 2013
<b>Chapter 3 Adapter for Oracle Applications Features</b>		
Support for Custom Integration Interfaces in Various Versions of Oracle E-Business Suite, page 3-4	Section revised to include the support for custom concurrent programs.	X
<b>Chapter 4 Adapter for Oracle Applications Concepts</b>		

---

<b>Sections</b>	<b>Changes Made</b>	<b>February 2013</b>
Flexfield Support for PL/SQL APIs, page 4-21	Section added to describe the flexfield support key features for PL/SQL APIs. It also describes how to configure or import flexfield mappings at design time during partner link creation, and how to view the mapped flexfields as part of the input payload at run time through examples.	X
<b>Chapter 7 Using Concurrent Programs</b>		
Overview of Concurrent Programs, page 7-1	Section revised to describe how to access custom concurrent programs through Oracle Applications Module Browser.	X
<b>Chapter 9 Using PL/SQL APIs</b>		
Add Partner Links, page 9-8	Section revised to include the steps for flexfield configuration if needed.	X
<b>Appendix B Troubleshooting and Workarounds</b>		
General Issues and Workarounds, page B-1	Section revised to include a workaround about the order of elements passed in XML should match the order sequence in the corresponding schema.	X

---

# Introduction to Adapter for Oracle Applications

## Overview of Adapter for Oracle Applications

Oracle Applications is a set of integrated business applications that runs entirely on the Internet. Oracle Applications offers you the following:

- Reduced costs
- Increased value across front-office and back-office functions
- Access to current, accurate, and consistent data

Oracle Applications are built on a unified information architecture that consolidates data from Oracle and non-Oracle applications and enables a consistent definition of customers, suppliers, partners, and employees across the entire enterprise. This results in a suite of applications that can give you information, such as current performance metrics, financial ratios, profit and loss summaries. To connect Oracle Applications to non-Oracle applications, you use Oracle Fusion Middleware Adapter for Oracle Applications.

Adapter for Oracle Applications not only provides comprehensive, bidirectional, multimodal, synchronous, and asynchronous connectivity to Oracle Applications, but also supports for all modules of Oracle Applications in Release 12, Release 11.5.10, and Release 11.5.9 including custom integration interfaces in various versions of Oracle E-Business Suite.

**Important:** Please note that Adapter for Oracle Applications is also informally known as Oracle E-Business Suite Adapter.

The support for various versions of Oracle E-Business Suite has the following conditions:

- Adapter for Oracle Applications supports Oracle E-Business Suite Release 11.5.9, as well as Release 12.0 and above.
- Adapter for Oracle Applications supports Oracle E-Business Suite Release 11.5.10 which works with OWF.G.Rollup 7 applied.
- To enable the native Oracle E-Business Suite connectivity using J2EE data sources feature, the minimum requirement for Oracle E-Business Suite Release 11i is 11i.ATG\_PF.H.Delta.6 (RUP6), and for Oracle E-Business Suite Release 12 is Release 12.0.4.

See "Oracle Fusion Middleware Adapter for Oracle Applications, Release 11g", My Oracle Support (formerly OracleMetaLink) Knowledge Document 787637.1 for details.

## Major Features

Adapter for Oracle Applications provides the following features:

- It leverages the Integration Repository to provide the information from the source of truth on integration.
- It supports the widest range of integration interface types. They are PL/SQL APIs, Business Events, Open Interface Tables, Concurrent Programs, XML Gateway Interfaces, e-Commerce Gateway Interface, and Interface Views.
- It generates adapter metadata as WSDL files with JCA extension.

**Note:** For more information, see *Oracle Fusion Middleware User's Guide for Technology Adapters*.

- It works under the securely configured connection between Oracle Applications and Oracle Fusion Middleware using just the FND User name and password for authentication.
- It leverages and supports Oracle User Management function security feature to allow only authorized users to access and execute APIs that they are exposed as Web services to update Oracle Applications.
- It implicitly takes care of applications context without bothering about the complexities of initiating the same explicitly.
- It supports multiple languages and multiple organization access control (MOAC) setup.

- It uses a JDeveloper based design-time tool for dynamically browsing the Oracle Applications interfaces and configuring the adapter metadata. The design-time tasks are wizard driven, user-friendly, and intuitive providing superior user experiences.
- It provides the global transaction control support implementing two-phase commit by leveraging the underlying JCA standards compliant framework.
- It supports multiple versions of Oracle E-Business Suite from the same instance of Adapter at design time as well as run time.
- It provides flexfield support for PL/SQL APIs that flexfield information is not only displayed at design time but also allows the runtime to work in the context of flexfields, not database columns.

## Architecture

Adapter for Oracle Applications is based on JCA 1.5 standards and deployed as a resource adapter within the Oracle WebLogic Server container. The architecture of Adapter for Oracle Applications is similar to the architecture of technology adapters.

### Adapter for Oracle Applications Architecture

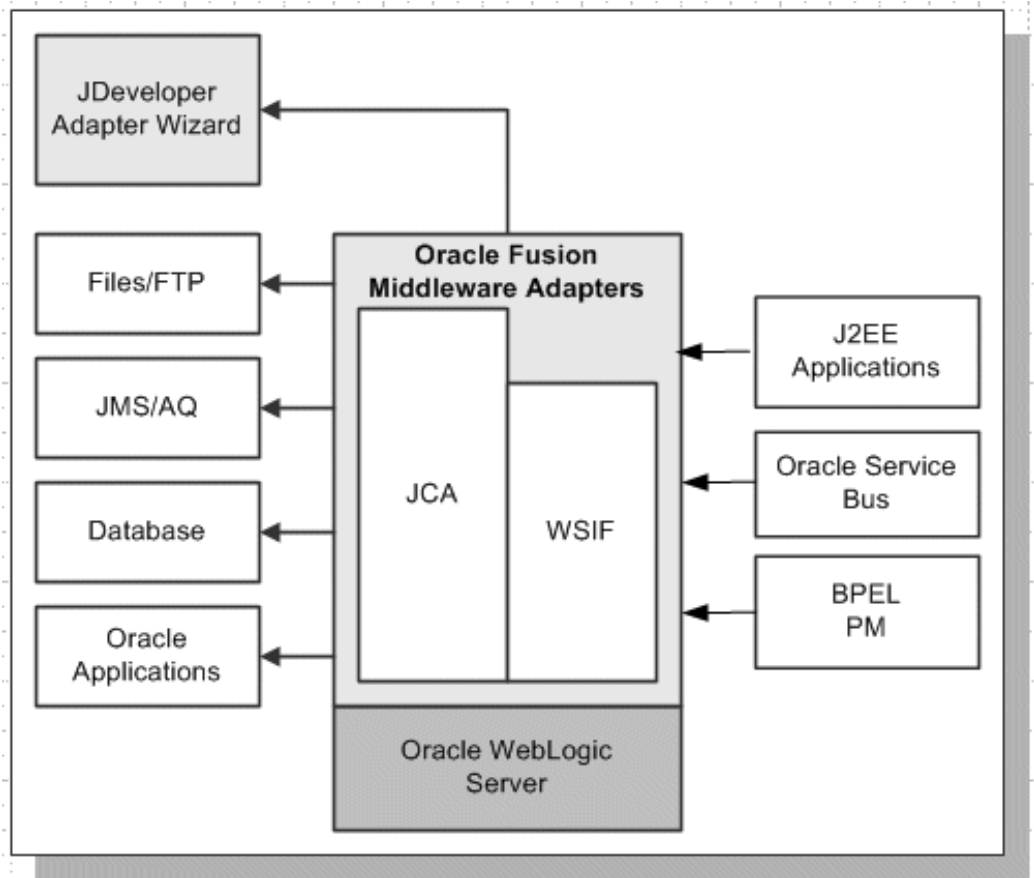

For more information on technology adapters, see *Oracle Fusion Middleware User's Guide for Technology Adapters*.

## Installing Adapter for Oracle Applications

Adapter for Oracle Applications and Oracle JCA Adapters are available as part of the Oracle Fusion Middleware install. In addition, these adapters support both Oracle WebLogic Server and middle tier deployments.

For more information, see *Oracle Fusion Middleware Installation Guide for Oracle SOA Suite and Oracle Business Process Management Suite*.

## Integration with Oracle Fusion Middleware

Adapter for Oracle Applications integrates with the JCA Binding Component of the Oracle Fusion Middleware platform; therefore, it integrates with service engines, such as Oracle BPEL Process Manager (Oracle BPEL PM) and Oracle Mediator.

Adapter for Oracle Applications can easily expose public integration interface within



Oracle E-Business Suite as standard Web services. These services can be created and configured in the Oracle JDeveloper at design time while integrating with Oracle BPEL PM and Oracle Mediator. At run time, Oracle E-Business Suite integration flows are deployed in the Oracle WebLogic Server for execution of the services to complete the integration.

- **Oracle BPEL Process Manager**

Based on the service-oriented architecture (SOA), Oracle BPEL Process Manager (BPEL PM) provides a comprehensive solution for creating, deploying, and managing Oracle BPEL Process Manager business processes.

- **Oracle Mediator**

Oracle Mediator provides a lightweight framework to route data from service providers to external partners. In addition, it can subscribe to and publish business events, as well as transform data using XSL Transformations.

For example, a Mediator can accept data contained in a text file from an application or service, transform it to a format appropriate for updating a database that serves as a customer repository, and then route and deliver the data to that database.

### **Design Time**

While integrating with Oracle BPEL PM and Oracle Mediator, Adapter for Oracle Applications uses Oracle JDeveloper as the design-time tool to create SOA Composite applications and generate WSDL and JCA files for the Web services.

When you create a partner link in Oracle JDeveloper BPEL Designer, the Adapter Configuration Wizard starts and allows you to select and configure the Adapters for Oracle Applications or other adapters. With proper database and service connection setups, you are presented with a functionally organized list of inbound and outbound interfaces available in your Oracle E-Business Suite instance for which you select the one that fulfill your requirements. When configuration is complete, the wizard generates a WSDL file corresponding to the XML schema for the partner link.

Additional process activities are added to the BPEL process if necessary to assign parameters and invoke the service.

### **Run Time**

Adapter for Oracle Applications is based on the JCA 1.5 specification. A Composite application including the BPEL processes, Mediator services, and partner link definitions generated at design time is deployed to the Oracle WebLogic Server. A JCA Binding Component acts as the glue layer that integrates the standard JCA 1.5 resource adapter with the Oracle BPEL Process Manager during run time. The JCA Binding Component acts as a pseudo JCA 1.5 container.

**Note:** Only the JCA 1.5 integration allows the BPEL PM to receive inbound events (from EIS to J2EE/BPEL PM). The Oracle BPEL Process

Manager acts as a pseudo JCA 1.5 container and implements the JCA 1.5-specific System Contracts. The JCA 1.5 resource adapter and the BPEL PM instance must be deployed in the same Oracle WebLogic Server container.

The Web service invocation launched by the BPEL Invoke activity contained in the SOA Composite is converted to a JCA CCI (Common Client Interface) outbound interaction, and the JCA response is converted back to a Web service response. This end-to-end invocation is synchronous.

#### *Testing the SOA Composite Application at Run Time*

After deploying the SOA Composite application, you should validate the design by testing the BPEL process contained in the deployed SOA Composite application to test the interface integration.

For detailed design-time and run-time tasks for each integration interface, see the individual interface chapter explained later in this book.

## **Integration with Oracle WebLogic Server**

Oracle WebLogic Server is a scalable, enterprise-ready Java Platform, Enterprise Edition (Java EE) application server. Its infrastructure enables enterprises to deploy mission-critical applications in a robust, secure, highly available, and scalable environment and is an ideal foundation for building applications based on service-oriented architectures (SOA). SOA is a design methodology aimed at maximizing the reuse of application services.

In addition, Oracle WebLogic Server consists of a JCA container for hosting JCA resource adapters. JCA defines standard Java interfaces for simplifying the integration of a J2EE server with various back-end applications. All client applications run within the Oracle WebLogic Server environment.

### **Design Time**

Oracle JDeveloper is used to create Web services represented in WSDL files and XML Schema Definition (XSD) files for the adapter request-response service.

The Oracle WebLogic Server clients use these XSD files during run time for calling the JCA outbound interaction.

### **Run Time**

Oracle Adapter for Oracle Applications is based on the JCA 1.5 specification and is deployed as resource adapter within the Oracle WebLogic Server container. The JCA 1.5 specification addresses the life-cycle management, message-inflow (for Adapter Event publish), and work management contracts.

For more information about using Oracle WebLogic Server with Oracle JDeveloper, see the Using WebLogic Server with Oracle JDeveloper section, *Oracle Fusion Middleware Installation Guide for Oracle JDeveloper*.

---

# Adapter for Oracle Applications Features

## Overview

Adapter for Oracle Applications enables you to orchestrate discrete data into a meaningful business process and creates Web services for various interface types within Oracle E-Business Suite. It plays the role of service provider for Oracle E-Business Suite to allow seamless integration between business partners, processes, applications, and end users in heterogeneous environment.

Adapter for Oracle Applications provides the following features which are further discussed in this chapter:

- Support for Various Integration Interface Types, page 3-1.
- Support for Oracle Integration Repository, page 3-3
- Support for Custom Integration Interfaces in Various Versions of Oracle E-Business Suite, page 3-4
- High Availability, page 3-7

## Support for Various Integration Interface Types

Adapter for Oracle Applications acts as a highly flexible integration interface for Oracle Applications. It supports the following interface types for integrating with Oracle Applications:

- **PL/SQL APIs**

These APIs enable you to insert and update data in Oracle Applications using PL/SQL.

- **Business Events**

A business event is an occurrence in an internet application that might be significant to other objects in a system or to external agents. An example of a business event can be the creation of a new sales order or changes to an existing order.

The Business Event System is an application service that leverages the Oracle Advanced Queuing (AQ) infrastructure to communicate business events between systems. The Business Event System consists of the Event Manager, which lets you register subscriptions to significant events.

When a local event occurs, the subscribing code is executed in the same transaction as the code that raised the event. Subscription processing can include executing custom code on the event information, sending event information to a workflow process, and sending event information to other queues or systems.

### **Business Event Groups**

A business event group is a type of event containing a set of individual business events. Once an event group is defined, a subscription that is registered for an event group will be executed when any of the individual events within it is triggered.

With the support for business event groups, different business events belonging to an even group can be handled through a single partner link. Service created for an event group would be able to dequeue payloads corresponding to any of the events within the group.

- **Open Interface Tables**

Interface tables enable you to insert or update data into Oracle Applications. The associated concurrent program should be running to move the data from the interface tables to base tables.

- **Concurrent Programs**

Concurrent programs enable you to move data from interface tables to base tables or execute any application logic.

- **Oracle XML Gateway**

XML Gateway enables bidirectional integration with Oracle Applications. It helps you to insert and retrieve data from Oracle Applications. XML Gateway is a higher-level interface that exposes OAGIS-formatted XML documents for commonly used Oracle Application business objects and business interfaces. XML Gateway integrates with interface tables, Oracle Workflow Business Event System (BES), and interface views to insert and retrieve data from Oracle Applications. It maps the underlying table data to XML and back.

- **Oracle e-Commerce (EDI) Gateway**

Oracle e-Commerce Gateway provides a common, standards-based approach for Electronic Data Interchange (EDI) integration between Oracle Applications and

third party applications.

- **Interface Views**

Interface views help you to retrieve data from Oracle Applications using the application tables.

Please note that Adapter for Oracle Applications also supports the following custom integration interface types that are exposed by the Oracle Applications Module Browser, not by Oracle Integration Repository:

- Custom PL/SQL APIs
- Custom Business Events

**Note:** Business events integration interface type is also exposed by Oracle Applications Module Browser, not by Oracle Integration Repository.

- Custom XML Gateway Maps
- Customized Concurrent Programs

## Support for Oracle Integration Repository

Oracle Integration Repository, an integral part of Oracle E-Business Suite, is a prebuilt catalog of information about the numerous public integration interfaces delivered with Oracle Applications. It provides a comprehensive view of the integration interfaces with details for Oracle E-Business Suite.

Oracle Integration Repository can only provide information about an integration interface that has been specifically annotated by the developer to make it public. Adapter for Oracle Applications takes advantage of the annotations that have already been created to make the following integration interface types visible in the Oracle Applications Module Browser:

- XML Gateway message maps
- PL/SQL APIs
- Concurrent programs
- Open Interface tables
- Interface views
- e-Commerce Gateway EDI messages

These integration interfaces are exposed as Web services, and are available for process orchestration through the Oracle BPEL Process Manager.

For more information about Oracle Integration Repository, see the Navigating Through Oracle Integration Repository section, *Oracle E-Business Suite Integrated SOA Gateway User's Guide*. This guide is part of the Oracle E-Business Suite Documentation Library which can be accessed on the Oracle Technology Network (OTN).

**Note:** Oracle Integration Repository is integral part of Oracle E-Business Suite Release 12.0 onwards; however, it is available as hosted environment for the Release 11.5.10 version at <http://irep.oracle.com>.

## Support for Custom Integration Interfaces in Various Versions of Oracle E-Business Suite

Oracle Adapter for Oracle Applications leverages Integration Repository for Oracle E-Business Suite Release 11.5.10 and Release 12 as the source of truth for the integration content. However, the implementation is based on the version of Oracle E-Business Suite. For Release 11.5.9 instance, Oracle Adapter for Oracle Applications connects directly to the application database for information on integration interfaces. Adapter for Oracle Applications also supports selecting custom integration interfaces and the design-time navigation steps to reach to these custom interfaces depending on the following versions of Oracle E-Business Suite:

- Release 12, page 3-5
- Release 11.5.10, page 3-6
- Release 11.5.9, page 3-6

**Important:** Please note that the support for various versions of Oracle E-Business Suite has the following conditions:

- Adapter for Oracle Applications supports Oracle E-Business Suite Release 11.5.9, as well as Release 12.0 and above.
- Adapter for Oracle Applications supports Oracle E-Business Suite Release 11.5.10 which works with OWF.G.Rollup 7 applied.
- To enable the native Oracle E-Business Suite connectivity using J2EE data sources feature, the minimum requirement for Oracle E-Business Suite Release 11*i* is 11*i*.ATG\_PF.H.Delta.6 (RUP6), and for Oracle E-Business Suite Release 12 is Release 12.0.4.

See "Oracle Fusion Middleware Adapter for Oracle Applications, Release 11g", My Oracle Support Knowledge Document 787637.1 for details.

From the business service creation and run-time perspectives, Adapter for Oracle Applications supports custom PL/SQL APIs as far as the packages are available in the APPS schema. The Oracle Applications Module Browser can expose these custom PL/SQL APIs for integration purposes during the design time.

### Support for Oracle E-Business Suite Release 12

From Release 12, Oracle Integration Repository is shipped as part of the Oracle E-Business Suite which enables Adapter for Oracle Applications to directly connect to the live database of Oracle Integration Repository querying for the public interfaces and then displaying the list of custom integration interfaces under the `Other Interfaces > Custom Objects` node in the Oracle Applications Module Browser.

### Supporting Custom Integration Interfaces in Release 12

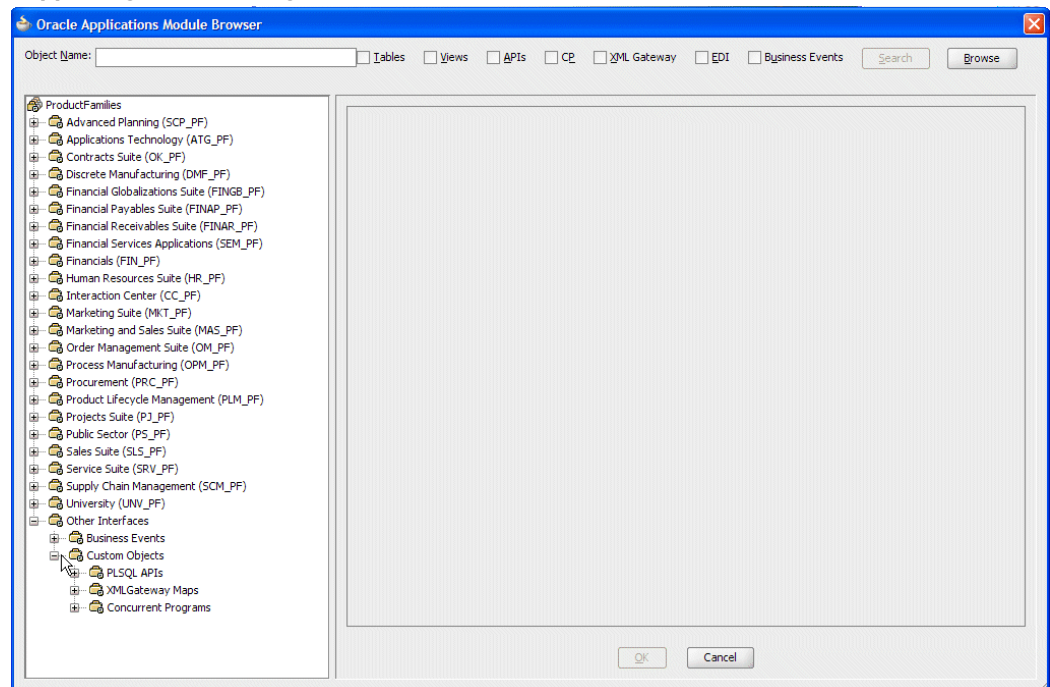

Please note that Adapter for Oracle Applications allows you to extract the Integration Repository data file from the live database you connect to Oracle Applications and create a local copy of the Integration Repository data file in your workplace. Next time when you look for public interfaces, the system can retrieve data from the cache in your workplace.

For detailed information about connecting to Oracle E-Business Suite Release 12, please

refer to the Creating a Partner Link or Adding a Partner Link design-time task for each integration interface.

### Support for Oracle E-Business Suite Release 11.5.10

To support Oracle E-Business Suite Release 11.5.10, Adapter for Oracle Applications provides the Integration Repository data file bundled as part of the product in xml format. During design time, Adapter for Oracle Applications queries public interfaces from the native XML data file of the Integration Repository shipped with Adapter. Custom integration interfaces are queried directly from the live database and displayed under the `Other Interfaces > Custom Objects` node in the Oracle Applications Module Browser.

#### Supporting Custom Integration Interfaces in Release 11.5.10

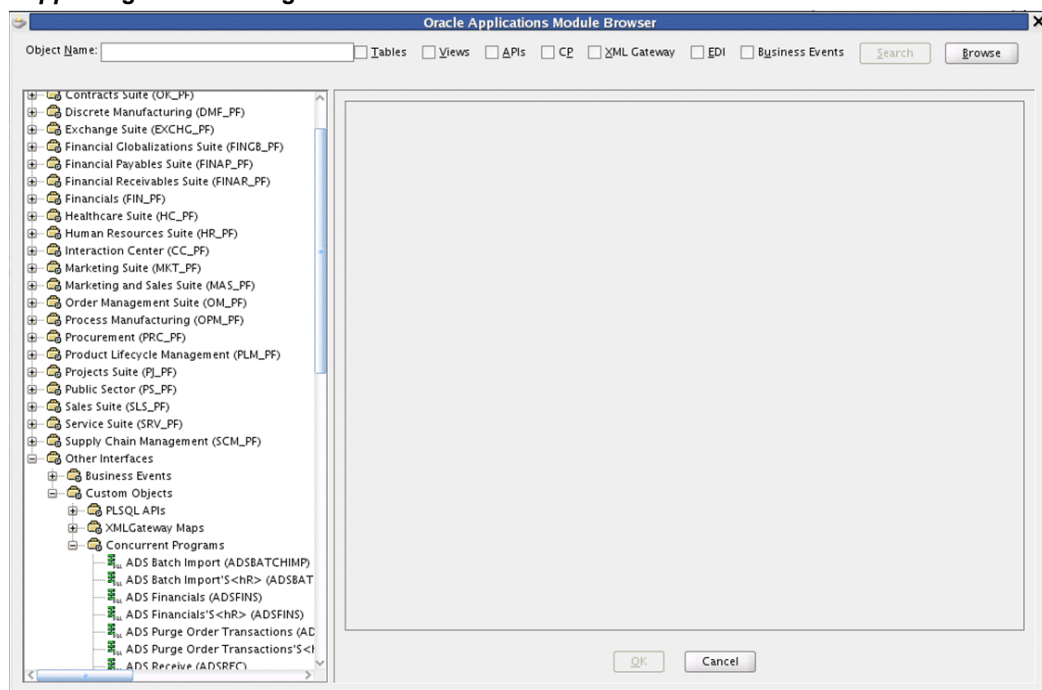

### Support for Oracle E-Business Suite Release 11.5.9

To support Oracle E-Business Suite Release 11.5.9, Oracle Adapter for Oracle Applications connects to the live application database for the integration information on all interface types. Since there is no differentiation between public, private, and custom PL/SQL APIs in the Release 11.5.9, Adapter for Oracle Applications displays them all under the node of each module through Oracle Applications Module Browser.

Before making a selection from the browser for the Release 11.5.9, you must select an interface type you want to use in the Adapter Configuration Wizard. All interfaces of your selected type will be displayed in the browser.

For example, you will find a list of concurrent programs associated with e-Commerce (EDI) Gateway displayed in the Oracle Application Module Browser as follows if the



EDI Gateway interface type is selected.

### Supporting Custom Integration Interfaces in Release 11.5.9

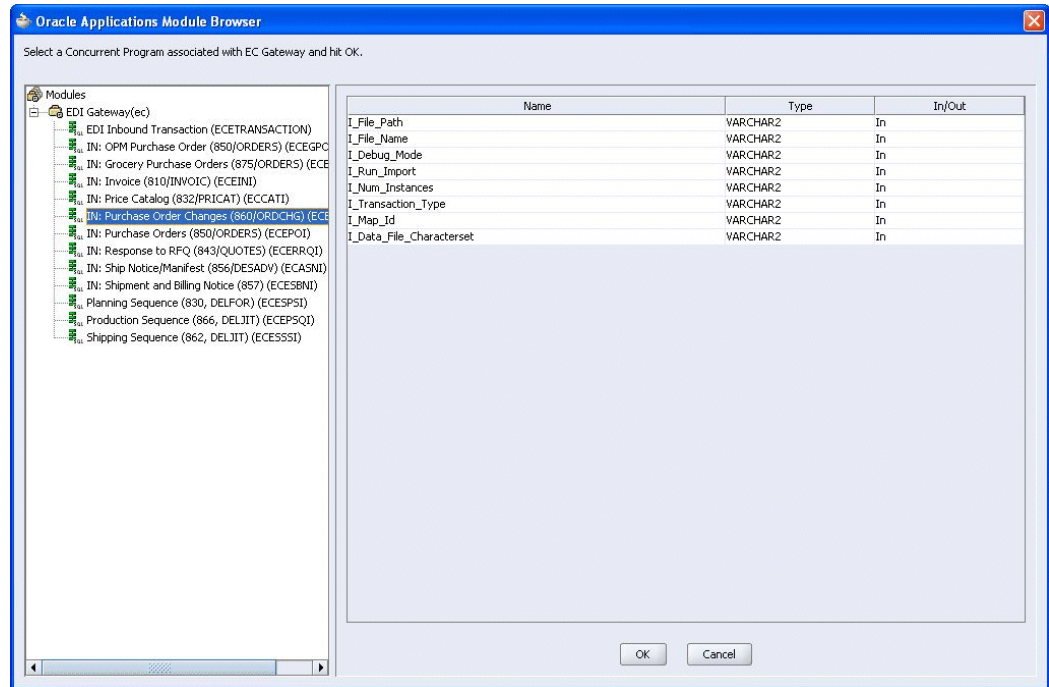

When you make a selection through the module browser at design time, Adapter for Oracle Applications validates your selected API against the database. If it exists in the database for a particular version of your instance, then the associated WSDL file will be generated successfully.

## High Availability

Oracle Adapter for Oracle Applications supports high availability by completely relying on the functionality of the underlying Oracle Database Adapter and Oracle AQ Adapter to support the scenarios, such as Real Application Cluster (RAC) database configuration or clustering configuration.

For information about Oracle Database Adapter and Oracle AQ Adapter, see *Oracle Fusion Middleware User's Guide for Technology Adapters*.



---

# Adapter for Oracle Applications Concepts

## Overview

This chapter discusses some essential concepts for Adapter for Oracle Applications. It provides basic understanding about how applications context, security, logging, and flexfields are used or supported as well as how errors and exceptions are handled. Detailed concepts described in this chapter are:

- Understanding Applications Context, page 4-1
- Understanding Adapter for Oracle Applications Security, page 4-14
- Flexfield Support for PL/SQL APIs, page 4-21
- Logging, page 4-81
- Enhanced Error and Exception Handling, page 4-96
- Secured Connection Between Oracle E-Business Suite and Oracle Fusion Middleware SOA Suite Using J2EE Data Source Implementation, page 4-97
- Understanding the Oracle Applications Module Browser, page 4-98

## Understanding Applications Context

Applications context is required for invoking interfaces within Oracle Applications. Applications context is a combination of **Username**, **Responsibility**, **Responsibility Application**, and **Security Group**. These elements may be required for executing an interface successfully within Oracle Applications.

## Applications Context in Multiple Organizations

You can define multiple organizations and the relationships between them in a single

installation of Oracle Applications. These organizations can be sets of books, business groups, legal entities, operating units, or inventory organizations.

Multilevel organization hierarchies can be defined with a business group at the top of each hierarchy. When you define new organizations, they are automatically assigned to the business group associated with your current session. Each organization is part of a business group. The business group is usually the top box on an enterprise organization chart.

### ***Business Group Hierarchy***

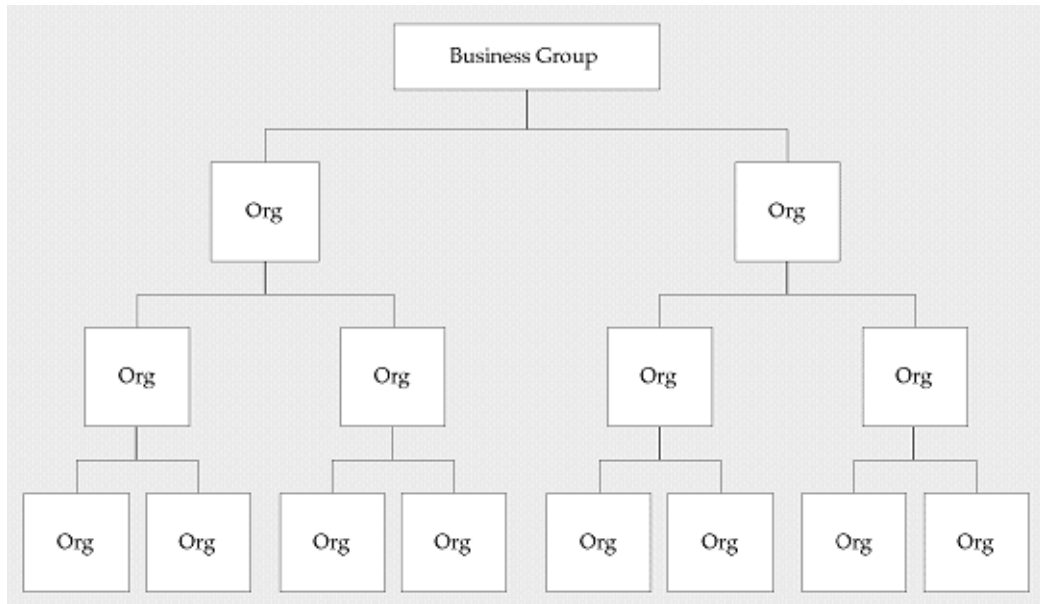

### **Example of a Multiple-Organization Setup**

Using the accounting, distribution, and materials management functions in Oracle Applications, you define the relationships among inventory organizations, operating units, legal entities, and sets of books to create a multilevel company structure, as shown in the following diagram.

### A Multiple-Organization Transaction

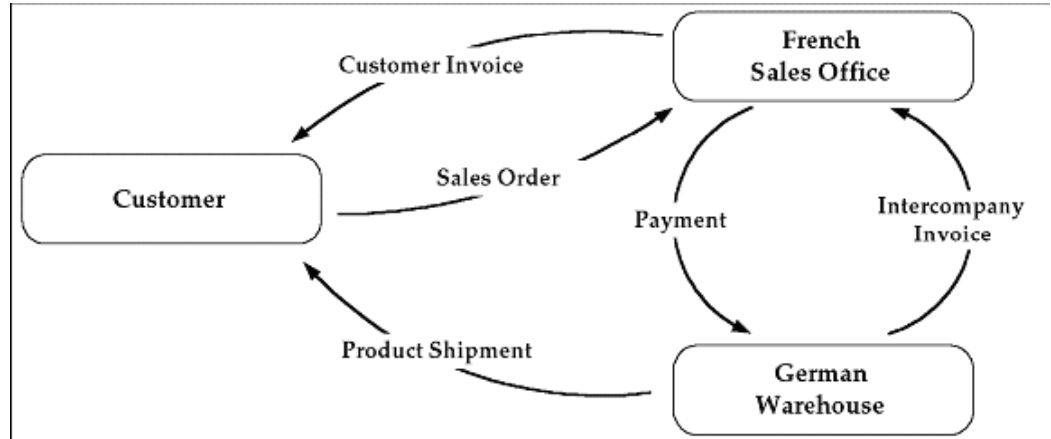

Consider two different organizations in your company: One is a French sales office and the other is a German warehouse. There is a sales order transaction with the customer, and this illustrates how the entire Order-to-Deliver process would work:

1. The customer places a sales order with the French sales office.
2. The German warehouse delivers the product shipment to the customer.
3. The German warehouse issues an inter-company invoice to the French sales office.
4. The French sales office makes the inter-company payment to the German warehouse.
5. The French sales office sends the customer invoice to the customer.
6. The customer makes payment to the French sales office.

The database architecture is the same for a multiple-organization and non-multiple-organization installation, and uses the standard install tools feature that automatically creates synonyms in the APPS schema for each base product table and defines these synonyms with the same name as the base product tables. For example, the PO Oracle schema has a table named PO\_HEADERS\_ALL and the APPS schema has a corresponding synonym of the same name, PO\_HEADERS\_ALL. The PO\_HEADERS\_ALL synonym can be used to access unpartitioned data.

### Schema Synonyms

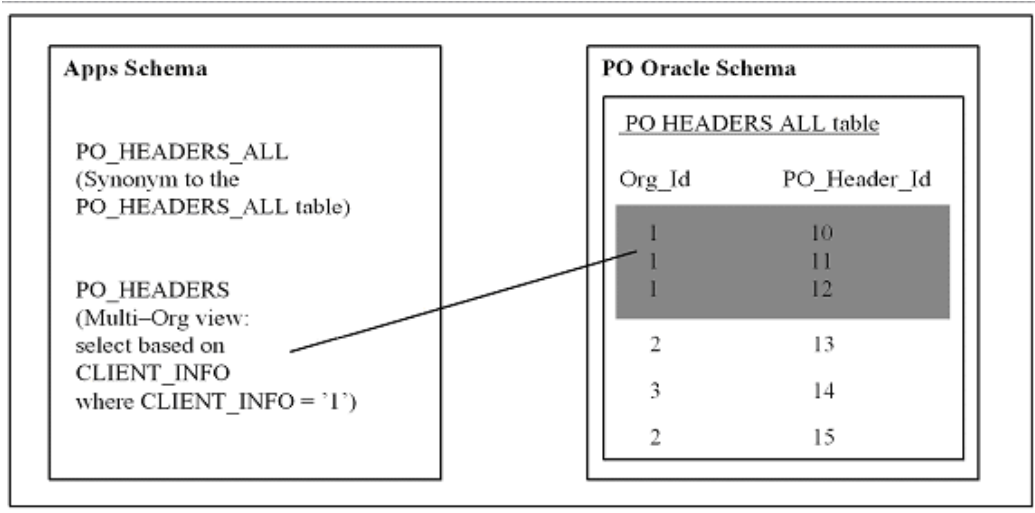

### Multi-Organization Access Control (MOAC) Security by Operating Units

While setting up the system profile values, the username and responsibility are tied up with the organization or operating units.

### Multiple-Organization System Profiles

Profile Option Name	Site	Application	Responsibility	User
MO: Default Operating Unit			Purchasing, Vision Operati	
MO: Distributed Environment	No			
MO: Operating Unit	Vision Operations		Vision Operations	
MO: Security Profile				
MO: Top Reporting Level	Operating Unit			

To have a secured way for users to allow access or report on data for the operating units they have access to, many of the interfaces within Oracle Applications make use of the MOAC security feature to determine the operating unit access privileges and derive the Organization ID based on relevant profile values. Adapter for Oracle Applications can implicitly perform the requisite MOAC setup. If ORG\_ID is passed, data access would be set to the passed Organization ID.

With MOAC, a system administrator can predefine the scope of access privileges as a security profile, and then use the profile option *MO: Security Profile* to associate the security profile with a responsibility. By using this approach, multiple operating units

are associated with a security profile and that security profile is then assigned to a responsibility. Therefore, through the access control of security profiles, users can access data in multiple operating units without changing responsibility.

Security profiles are defined based on organization hierarchies. For example, a sales company consists of USA and UK operating units; the USA operating unit has Western Region Sales and East Region Sales. Sales managers are responsible for both USA and UK sales, supervisors are responsible for either USA or UK, and sales representatives are only responsible for their designated sales regions. The Sales organization hierarchy can be illustrated as follows:

**Sales Organization Hierarchy**

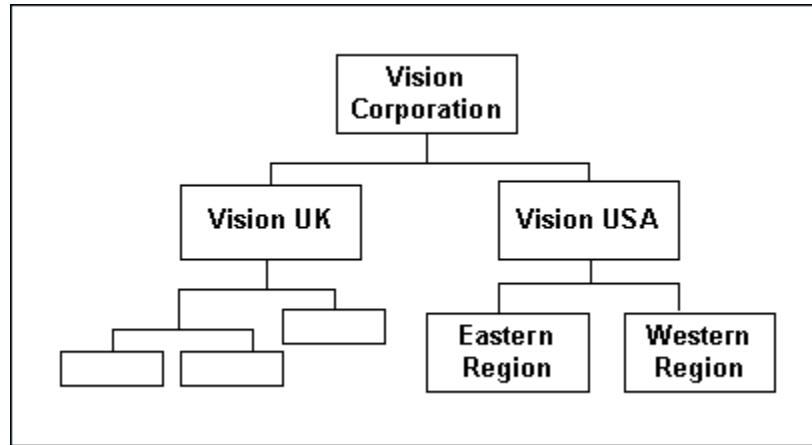

To secure sales data within the company, relevant operating units can be associated with predefined security profiles. For example, all sales data access privileges are grouped into the Vision Sales security profile. A USA Sales security profile is created for USA related data, and a regional security profile is created for designated regional data. The system administrator can associate these security profiles containing multiple operating units with users through appropriate *responsibilities*. Therefore, sales supervisors can easily access sales data in the Eastern or Western region without changing their responsibilities. The following diagram illustrates the relationship between security profiles, responsibilities, and operating units for this sales company:

**Relationship Diagram Between Security Profiles, Responsibilities, and Operating Units**

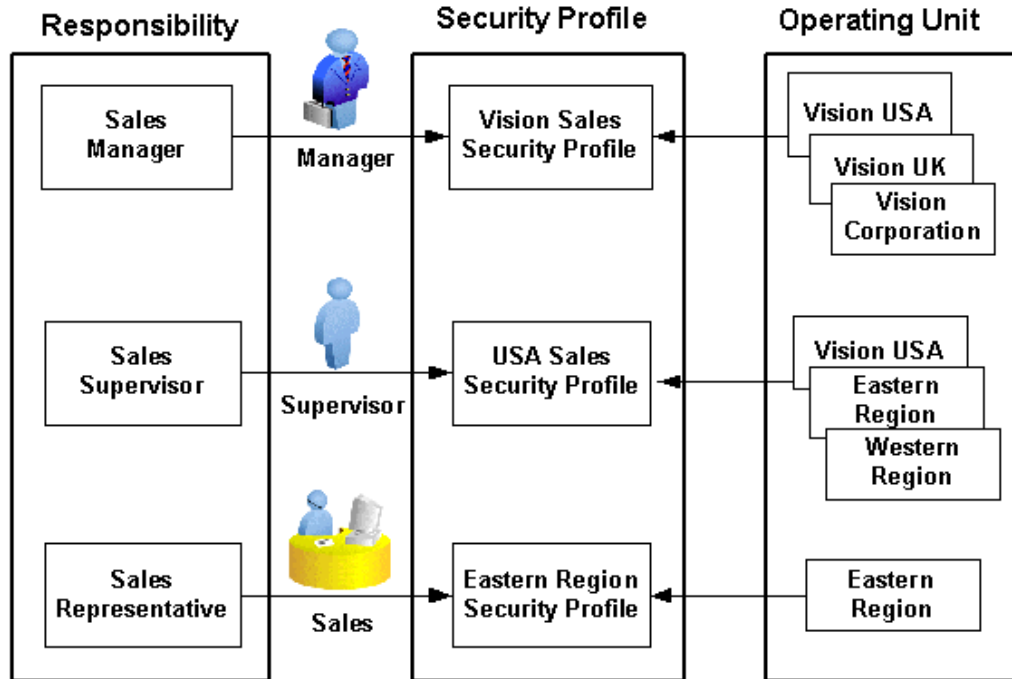

### Responsibility Determines Operating Units

Because responsibilities are associated with security profiles that linked to operating units, your responsibility is the key in determining which operating units you will have the access privileges.

1. When integrating with Oracle Applications using PL/SQL APIs or Concurrent Programs, applications context is set based on the values passed for the header properties Username, Responsibility, Responsibility Application and Security Group.

**Note:** For backward compatibility reasons, no context related exceptions or errors would be thrown if none of the following header properties are passed - Responsibility Application, Security Group, and NLS Language.

2. MOAC setup is done based on the Responsibility Application to which the user belongs. If Organization ID is passed, the Organization access would be set to the passed Organization.
3. If the user needs the invocation of the interface to happen in a desired language, then the header property NLS Language can be passed. Default value for NLS Language would be the language specified in the user's preference in Oracle



Applications.

To integrate business processes with Oracle Applications, it is essential to propagate these applications context values through a flexible mechanism, which is provided by Adapter for Oracle Applications through the header properties.

The following topics are discussed in this section:

- Support for Normalized Message Properties, page 4-7
- Support for Multiple Organization Access Control (MOAC), page 4-11
- Support for Multiple Languages, page 4-12

## Support for Normalized Message Properties

To effectively set applications context values required in a BPEL process or to populate mandatory header variables for XML Gateway inbound transactions to be completed successfully, Adapter for Oracle Applications provides a flexible mechanism that allows each context value and header variable to be set and passed in the adapter user interface directly through the Invoke activity. This message normalization feature not only provides a flexible solution on header support, but also simplifies the design-time tasks without using an Assign activity to pass header values.

### Setting Message Properties for Applications Context

The following header properties are used in setting applications context for PL/SQL and Concurrent Program interfaces:

- `jca.apps.Username`
- `jca.apps.Responsibility`
- `jca.apps.ORG_ID`
- `jca.apps.RespApplication`
- `jca.apps.SecurityGroup`

**Note:** Existing header property `jca.apps.Responsibility` used in the earlier releases can now take Responsibility Key as well as Responsibility Name as input. If the header property `jca.apps.NLSLanguage` is set, and Responsibility Name is passed, the value passed for `jca.apps.Responsibility` is expected to be in the same language. However, Responsibility Key as well as all other header properties are language independent.

All these header properties would be used together to set the application context. Alternatively, passing just the Username and

Responsibility would work as it did in the earlier releases.

In the case of a null or empty value, the default Username is `SYSADMIN`, the default Responsibility is `System Administrator`, the default Security Group Key is `Standard`, and the default NLS Language is `US`.

### **Setting Message Properties for XML Gateway Inbound Transactions**

The following header message properties are used in setting XML Gateway information required for XML Gateway inbound/enqueue transactions:

- `jca.apps.ecx.TransactionType`
- `jca.apps.ecx.TransactionSubtype`
- `jca.apps.ecx.PartySiteId`
- `jca.apps.ecx.MessageType`
- `jca.apps.ecx.MessageStandard`
- `jca.apps.ecx.DocumentNumber`
- `jca.apps.ecx.ProtocolType`
- `jca.apps.ecx.ProtocolAddress`
- `jca.apps.ecx.Username`
- `jca.apps.ecx.Password`
- `jca.apps.ecx.Attribute1`
- `jca.apps.ecx.Attribute2`
- `jca.apps.ecx.Attribute3`
- `jca.apps.ecx.Attribute4`
- `jca.apps.ecx.Attribute5`
- `jca.apps.ecx.Payload`

### **Design-Time Tasks for Message Properties Support**

Adapter for Oracle Applications uses the following procedures to complete the design-time tasks to support message normalization:

1. Create a new SOA Composite application with BPEL process, page 5-8
2. Create a partner link, page 5-12

### 3. Configure an Invoke Activity, page 5-65

This activity involves the following tasks:

- *Configure basic information in the General tab:*

Configure an **Invoke** activity by linking the activity to the partner link you just created. This opens the General tab in the Edit Invoke dialog box with Partner Link and Operation information populated.

You can create an Input Variable and a Output Variable for the Invoke activity.

For detailed instructions, see *Configure basic information in the General tab*, page 5-27

- *Set the Header Message Properties in the Properties tab:*

This is to set the necessary message properties for the following purposes:

- To set XML Gateway header variables for an inbound transaction.

For example, locate XML Gateway header property

`jca.apps.ecx.TransactionType` first and then enter a value (such as 'PO') for the selected property.

### Entering a Selected Property Value

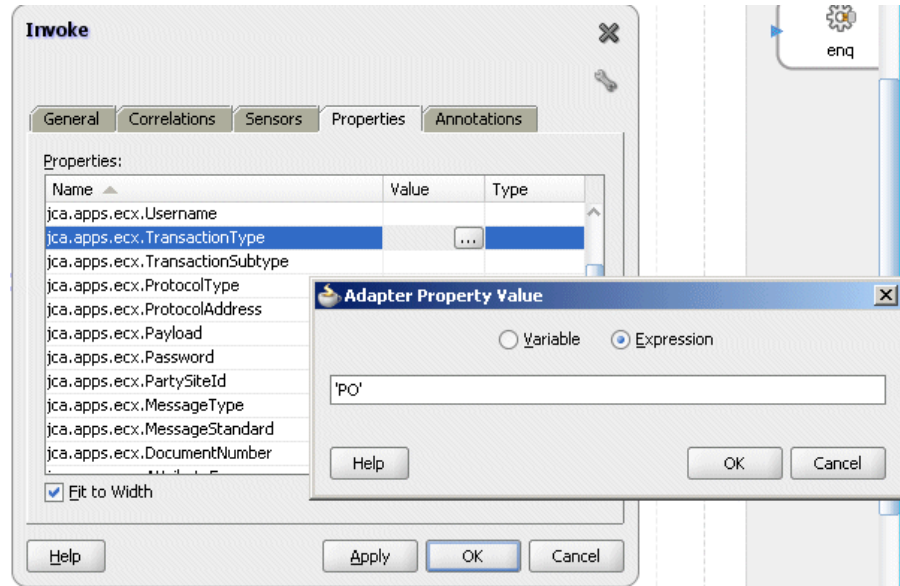

For detailed instructions, see [Setting ECX Header Message Properties](#), page 5-30.

- To set applications context for Oracle Applications to identify the application user, responsibility, and the user's associated organization information.

For example, locate the `jca.apps.Username` property from the property list and then enter 'OPERATIONS' as the property value.

### Header Property Values

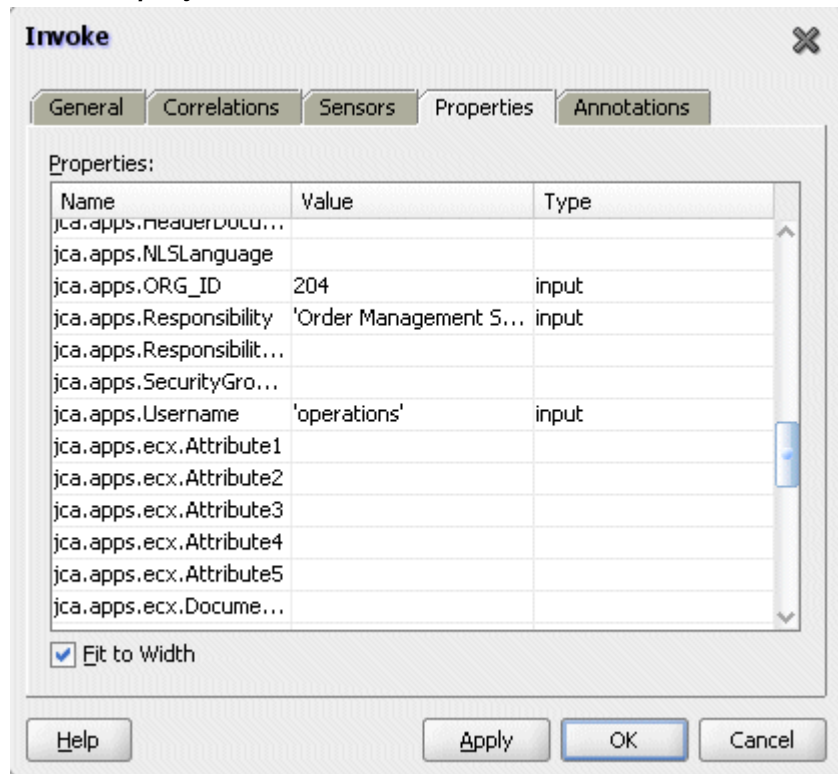

For detailed instructions, see *Setting the Header Properties for Applications Context*, page 7-47.

## Support for Multiple Organization Access Control (MOAC)

Adapter for Oracle Applications allows Organization ID to be passed as a header property which is available as `jca.apps.ORG_ID` within the Properties tab of an Invoke activity during the design time.

On Oracle Applications subsequent to Release 12.0, MOAC setup is automatically done using the call `MO_GLOBAL.INIT(<Application Name>)`. Subsequently, if `ORG_ID` is passed, the call to `MO_GLOBAL.set_policy_context('S', <ORG_ID>)` would be made to set the Organization access to the specified `ORG_ID`.

### Setting Header Message Properties

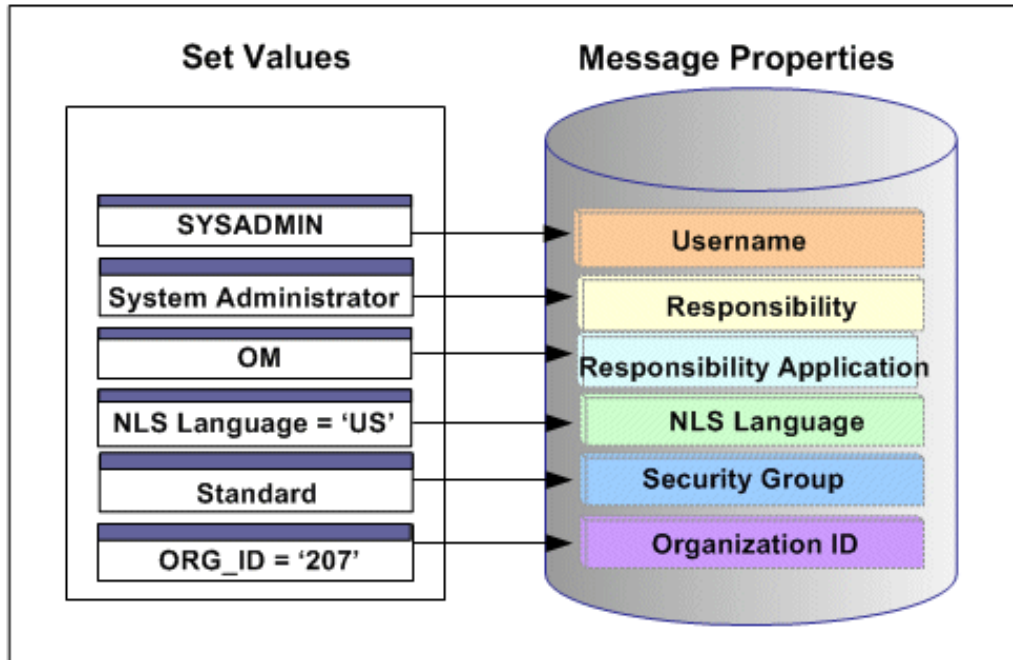

With the example described earlier in the Multiple Organization Setup section, when a change order is placed within the French sales office, a sales manager from the French office logs on to the system to update the order which invokes a PL/SQL API for that change. If the Organization ID contained in the header has been assigned with a property value, such as 207 for the French sales office, the Organization ID associated with the sales manager will be set to French sales office for the invocation of the API.

## Support for Multiple Languages

By leveraging the message normalization feature addressed earlier and the Multiple Language Support (MLS) feature from Oracle E-Business Suite, Adapter for Oracle Applications provides a comprehensive language support mechanism that allows an appropriate language to be dynamically set at run time.

### NLS Language Property Value Takes the Priority

When an application user retrieves data from the system for a transaction or receives error messages while executing APIs, the session language of data or error messages can be determined based on the following conditions:

1. The NLS Language value can be set by using the header property `jca.apps.NLSLanguage`. If a valid language value is passed (i.e. language is enabled in Oracle E-Business Suite instance), the session language is set to the corresponding language.

2. In case the NLS Language header property is not passed, Adapter for Oracle Applications will use the default language of the user, based on the user preferences, to set the session language.
3. If the user's default language is not found or set, NLS Language (`java.apps.NLSLanguage`) property value would be set to 'US' (American).

This mechanism allows an appropriate session language to be dynamically set at run time first based on the passed NLS Language property value, then the user's default language, and last determined by the default NLS Language property value 'US'.

For more information about how to set NLS Language property value by using `java.apps.NLSLanguage`, see Support for Normalized Message Properties, page 4-7.

### Determining a User's Default Language

To identify the default language used in the database session for data query and retrieval, Adapter for Oracle Applications will first examine the *ICX: Language* profile value at all levels including user, responsibility, application, and site. If it is not set at any of those levels, Adapter for Oracle Applications then takes `NLS_LANGUAGE` parameter from the database instance National Language Support (NLS) parameters. The NLS parameters initialized in the session are:

- `NLS_LANGUAGE`
- `NLS_SORT`
- `NLS_DATE_FORMAT`
- `NLS_DATE_LANGUAGE`
- `NLS_NUMERIC_CHARACTERS`
- `NLS_TERRITORY`

For example, when a user with a default language Japanese logs into the system and performs a transaction through the execution of an API that the user defined in the Partner link of the BPEL process, Adapter for Oracle Applications will first examine if the NLS Language property value is passed. If it is passed with a valid language, then the session language will be set based on the passed value regardless of the default language. If the NLS Language property is not passed, Adapter for Oracle Applications will set the session language to the preferred / default language of the user. In case that cannot be found, the language would be set to 'US' (American). The default language is set in the General Preferences page of Oracle Applications.

**Note:** The default language set in the General Preference page updates the *ICX: Language* profile option.

When the applications context is set, user preferences like date formats, time zone information, etc. would be taken care automatically.

Please refer to the Set Preferences section, Getting Started with Oracle E-Business Suite chapter, *Oracle E-Business Suite User's Guide* for the information on how to set the user preferences.

## Understanding Adapter for Oracle Applications Security

Security is the most critical feature that is designed to guard application content from unauthorized access. By leveraging Oracle User Management security mechanism, Adapter for Oracle Applications provides a security feature which only allows users with authorized privileges to execute APIs that they are exposed through the BPEL process to update Oracle Applications. This protects application programming interfaces (APIs) from unauthorized access or execution without security checks.

### Function Security with Role-Based Access Control (RBAC)

Function security is the basic access control in Oracle Applications. It restricts user access to individual menus and menu options within the system regardless of which application data in the row. Since APIs are stored procedures that enable you to insert and update data in Oracle Applications, when having the function security layer enforced on the access to an API, it actually implicitly restricts the data access to the application.

Building on function security, data security provides another layer of security control to model or enforce security authorizations of specific data records. In other words, data security further refines the security of accessing application records down to the data level.

To provide granular security control and allow only appropriate users with right privileges to execute APIs, Adapter for Oracle Applications leverages Oracle User Management Role-Based Access Control security (RBAC) to reinforce the function security through user roles. Whether a user can access an API is determined by the roles granted to the user. This approach builds upon data security and function security, but it goes beyond both of them.



## Function Security with Role-Based Access Control

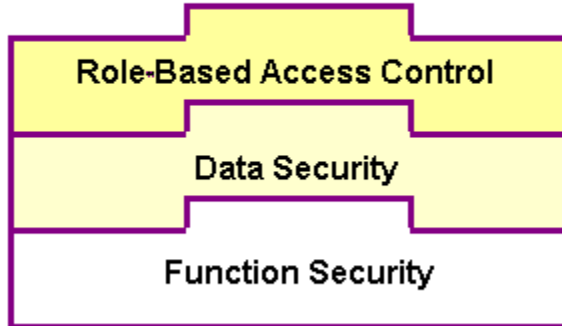

To better understand how the security works for Oracle Adapter for Oracle Applications, the following topics are included in this section:

- Function Security Support for Overloaded Functions, page 4-15
- Function Security Support through Profile Option, page 4-16

### Function Security Support for Overloaded Functions

Adapter for Oracle Applications now provides a way to handle access control for overloaded PL/SQL APIs. This feature works in conjunction with the grants created from the Integration Repository user interface, and it does not depend on any profile options.

**Note:** This security support would work with all interfaces which are available in the Integration Repository. For other interfaces, you need to enable the function security through the profile option mentioned in the section Function Security Support through Profile Option, page 4-16.

For this purpose, two new JCA properties are introduced:

- DataSecurityCheck
- IRepOverloadSeq

If a user wants the Function Security Authorization check to be performed, the following property information needs to be added in the WSDL file (`xx_apps.jca`):

```
<property name="DataSecurityCheck" value="yes"/>
```

However, the other property `IRepOverloadSeq` is derived automatically by Adapter

for Oracle Applications at the design time during creation of the partner link. Based on these two properties, the function security check would be done for the username, which is passed as a header property.

### Creating Security Grants through Integration Repository

This type of data security check for overloaded functions works in conjunction with security grants created through the Integration Repository user interface. This security grant can be performed in the Create Grant page for a given interface type to control the method at a very granular level.

An integration repository administrator can select one or more methods in a PL/SQL API and then authorize a user, user group, or all users to execute the selected method(s) by creating appropriate security grants.

#### Creating Grants in Integration Repository

The screenshot shows the Oracle Integration Repository user interface. At the top, there's a navigation bar with 'ORACLE Integration Repository' and links for 'Navigator', 'Favorites', 'Home', 'Logout', 'Preferences', 'Help', and 'Diagnostics'. Below this, there's a breadcrumb trail: 'Integration Repository > Administration > PLSQL Interface : Payment Instrument Registration > Create Grants'. The main content area has a 'Selected Methods' table with two rows, both showing 'Query Payment Instrument ORAINSTRINQ' and a green checkmark in the 'Internal Name Overloaded' column. Below the table, there's a 'Grant All Selected' section with a 'Grantee Type' dropdown set to 'Specific User' and a 'Grantee Name' input field with a search icon. At the bottom, there are 'Cancel' and 'Apply' buttons. The footer contains 'About this Page', 'Privacy Statement', and 'Copyright (c) 2006, Oracle. All rights reserved.'

In the Integration Repository user interface, each overloaded function contained in an interface can be uniquely granted to a specific user, user group, or all users through the create grant feature. If you select more than one overloaded function in the Procedures and Functions region (or the Methods region), in the Create Grant page an Overloaded column appears in the selected methods table indicating more than one overloaded function is selected for the grant.

For more information on how to create security grants using the Integration Repository user interface, see *Managing Security Grants, Administering Native Integration Interfaces and Services* chapter, *Oracle E-Business Suite Integrated SOA Gateway Implementation Guide* for details.

### Function Security Support through Profile Option

Based on the function security with Role-Based Access Control (RBAC), security access control is defined through user roles and whether a user can access an API is

determined by the roles granted to the user. A role can be configured to consolidate the responsibilities, permissions, permission sets, and function security policies that users require to perform a specific function. This simplifies mass updates of user permissions because changes can be done through roles which will inherit the new sets of permissions automatically. Based on the job functions, each role can be assigned a specific permission or permission set if needed. For example, a procurement organization may include 'Buyer', 'Purchasing Manager', and 'Purchasing Support' roles. The 'Purchasing Manager' role would include a permission set that contains all Purchase Order (PO) Creation, PO Change, and Contract PO related APIs allowing the manager role to perform a job function while the Buyer or Support role may not have the access privileges.

In Adapter for Oracle Applications, all annotated APIs that reside in Oracle Integration Repository are registered on the FND\_FORM\_FUNCTIONS table so that the function security (FND\_FORM\_FUNCTIONS) can be applied. This allows the creation of a secured function for each API.

By leveraging the concept of permission sets, Adapter for Oracle Applications allows related APIs to be grouped and sequenced under one permission set; each permission set can be associated with a function role and then assigned to users through security grants.

### **Enabling Function Security**

Adapter for Oracle Applications provides this security support as an optional feature. If you want all the login users to access and execute APIs without security checks, you can turn the security feature off using the "EBS Adapter for BPEL, Function Security Enabled" (EBS\_ADAPTER\_FUNCTION\_SEC\_ENABLED) profile option.

**Note:** Using "DataSecurityCheck" described in the earlier section for overloaded functions is the preferred way for interfaces listed in the Integration Repository because it is easy to create the security grants and doesn't depend on any profile options.

- If it is set to 'Y', then the function security feature is enabled and all API calls for PL/SQL APIs, Oracle e-Commerce Gateway, and concurrent programs will be checked for user security before they are invoked.
- If it is set to 'N' (default value), then the function security feature is disabled. No security check is implemented during the invocation of all API calls.

When a user tries to invoke an API within the Oracle E-Business Suite through a BPEL process, if the function security profile is enabled, the invocation of the API would happen only after validation of the authorization privileges on the API.

For example, if a user does not have the access privileges for a PL/SQL API exposed through a BPEL process, the execution of that BPEL process will fail while trying to invoke the PL/SQL API. Without the authorized privileges, the Function Security Validation Exception message will be raised indicating that the user does not have the

privilege for a specific PL/SQL API.

For more information about this feature, see "Oracle Fusion Middleware Adapter for Oracle Applications, Release 11g", My Oracle Support Knowledge Document 787637.1 for details. For more information on Function Security and RBAC security models, see *Oracle E-Business Suite System Administrator's Guide - Security* for details.

## Creating Security Grants through User Roles

To secure the API invocation only to a user with appropriate execution privileges, the following steps need to be performed on Oracle Applications to create security grants for the user using user roles:

1. Creating a Permission Set, page 4-18
2. Creating a User Role, page 4-20
3. Granting a Permission Set to a User Through a Role, page 4-21

## Creating a Permission Set

Use the following steps to create a permission set:

1. Log in to Oracle E-Business Suite using the System Administrator responsibility.
2. Select Application: Menu from the Navigator to access the Menus window.
3. Enter the following menu information:
  - Menu: Enter an appropriate menu name (such as 'OE\_PROCESS\_LINE\_PS').
  - User Menu Name: Enter an appropriate user menu name (such as 'Order Manager Process Line Permission Set').
  - Menu Type: Permission Set
  - Description: Enter description information for this menu.
4. Add all the functions that you want to group on this Permission Set by entering values for Seq and Function.
  1. Enter the Seq field.
  2. In the Function column, search for the functions you want to assign to this permission set.

Select an appropriate function name by performing a search in the Functions window. For example the syntax for searching public PL/SQL APIs is:

PLSQL:<package name>:<procedure name>. You can enter %PLSQL:OE% in the Find field and click **Find** to execute the search.

### Searching for Functions

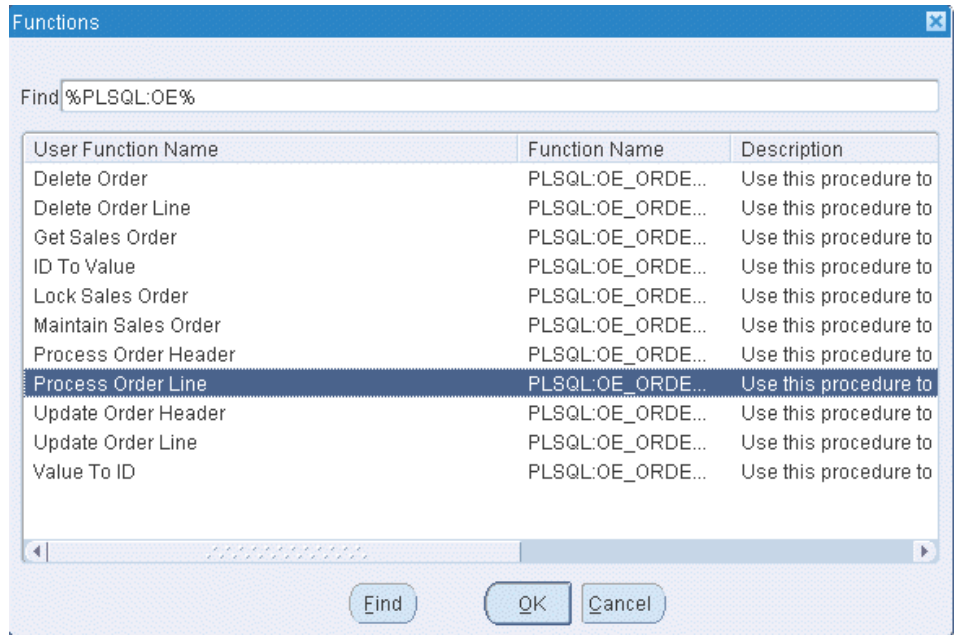

Based on your Composite application, select appropriate functions and then grant permissions to the API that you will be invoking from the BPEL process or Mediator.

For example, for a sales order line change BPEL process, you select sales order line change related functions contained in the order change PL/SQL API and group them as a permission set, and then grant the permission set to an appropriate user through a role.

See: [Creating a User Role](#), page 4-20.

### Permission Set Menu

Seq	Prompt	Submenu	Function	Description	Grant
1			Process Order Line		<input checked="" type="checkbox"/>
2			Delete Order Line		<input checked="" type="checkbox"/>
					<input type="checkbox"/>
					<input type="checkbox"/>
					<input type="checkbox"/>
					<input type="checkbox"/>
					<input type="checkbox"/>
					<input type="checkbox"/>
					<input type="checkbox"/>
					<input type="checkbox"/>
					<input type="checkbox"/>

5. Save the Permission Set.

### Creating a User Role

Permission sets are granted through user roles. Therefore, you must first create a role and then assign the role to a user.

Use the following steps to create a user role:

1. Log in to Oracle E-Business Suite using the User Management responsibility.
2. Select Roles & Role Inheritance from the Navigator to access the Roles & Role Inheritance page.
3. Click **Create Role** to access the Create Role page.
4. Enter the following information to create a role:
  - Category: Select Miscellaneous from the drop-down list.
  - Role Code: Enter an appropriate role code (such as 'EBS\_ADAPTER\_ROLE').
  - Display Name: Enter appropriate information for the display name (such as 'EBS Adapter Role').
  - Description: Enter appropriate information for the description (such as 'EBS Adapter Role').

- Application: Select an appropriate application (such as 'Application Object Library').
  - Active Date: Enter an appropriate date which is earlier than or equal to today's date so that the role can become valid right away.
5. Save the information and click **Create Grant**.
  6. Enter the following information in the Create Grant: Define Grant page:
    - Name: Enter an appropriate name (such as 'EBS\_ADAPTER\_GRANT').
    - Description: Enter description information for this grant.
  7. Click **Next**.
  8. In the Create Grant: Define Object Parameters and Select Set page, select the Permission Set you created earlier in the Creating a Permission Set section, page 4-18 and click **Next**.
  9. Click **Finish**.

#### **Granting a Permission Set to a User Through a Role**

Use the following steps to grant a permission set to a user through a role:

1. Log in to Oracle E-Business Suite using the User Management responsibility.
2. Select Users from the Navigator to access the User Maintenance page.
3. Search for the user you want to assign the role and click **Go**.
4. Select the **Update** icon next to the user name that you want to assign the role.
5. In the Update User page, click **Assign Roles** to have the Search window populated which allows you to search for the role that you created earlier.
6. Select the role (such as 'EBS\_ADAPTER\_ROLE') and save your update.

## **Flexfield Support for PL/SQL APIs**

Oracle Adapter for Oracle Applications provides flexfield support for PL/SQL APIs. If a PL/SQL interface is configured with flexfields, flexfield information including flexfield data and mapping will not only be displayed at design time, but also be included in the XSD. Additionally, this feature allows Adapter for Oracle Applications runtime to work in the context of flexfields.

**Note:** Please note that flexfield information was not displayed at design time in earlier releases, but generic API parameter names were displayed instead. The XSD for the payload also showed the generic parameter names instead of the flexfield information.

This feature is available for PL/SQL APIs only and is for Oracle E-Business Suite Release 12 and above.

### *What is a Flexfield?*

Flexfield is one of the essential features in Oracle E-Business Suite. It provides a flexible way to represent objects or to implement context-sensitive fields that appear only when needed. It is a field made up of sub-fields, or segments. Two flexfield types (key and descriptive flexfields) are used to let you customize Oracle E-Business Suite features without additional programming. To provide the unique, customized information that conforms to your business needs, Adapter for Oracle Applications provides flexfield support for PL/SQL APIs that contain flexfields.

### *How Flexfield Data is Configured at Design Time*

At design time during the partner link creation, if a PL/SQL interface is configured with flexfields, appropriate flexfield information is displayed along with the API parameters in the right pane of the Oracle Application Module Browser. You can optionally modify or create a new flexfield mapping for the selected API, or proceed with the partner link creation without configuring the PL/SQL API with flexfields.

To configure flexfield data, Adapter for Oracle Applications allows you to either use an existing flexfield mapping that has been created earlier, or to create a new mapping if desired. In the case of creating a new mapping, a mapping flexfield wizard appears guiding you through each configuration page where you can add key and descriptive flexfields with desired mapping for the selected API.

### **Key Features**

Flexfield feature provided in Oracle Adapter for Oracle Applications includes the following key features:

- It displays flexfield information which contains the mapping of API parameter names and the corresponding flexfield segment names in the Oracle Application Module Browser.
- It lets you configure and modify both key flexfields and descriptive flexfields.
- It provides a flexible mapping support mechanism for a selected API that you can configure a new mapping or reuse a previously created mapping through import.

**Note:** A flexfield can be mapped only once for a PL/SQL API. Duplicate flexfields are not allowed.



- Once a flexfield mapping is completed and partner link is created, an enhanced schema (XSD) is generated using flexfield names instead of the generic parameter names.
- It allows the Adapter for Oracle Applications runtime to work in conjunction with the support from Oracle Database Adapter to handle the enhanced schema.

## Understanding Key Elements in Flexfield Configuration

Oracle Adapter for Oracle Applications supports both key flexfields and descriptive flexfields referenced by an API.

- **Key Flexfields**

Use key flexfields as identifiers for entities. Generally, the identifier you create using a key flexfield is required by the application. For example, an Accounting Flexfield is used to create and display account numbers. This key flexfield is owned by Oracle General Ledger, but its values can be used by many of the applications.

A key flexfield structure usually consists of multiple segments and each segment contains meaningful information. For example, the Accounting Flexfield structure can consist of five segments such as Company, Department, Account, Sub-Account, and Product.

- **Descriptive Flexfields**

Use descriptive flexfields to gather additional specialized, important, and unique information required by your business. In other words, this type of flexfield is used to collect information beyond what is collected by Oracle E-Business Suite.

A descriptive flexfield typically uses multiple structures. Each of these structures can have different segments to gather different data. Each segment's value is stored in a column in one of the application's base tables. The column name reflects the type of flexfield data it holds. In general, key flexfields store their data in columns called SEGMENTn; descriptive flexfields store their data in columns called ATTRIBUTEn, where n is a number.

Generally, use key flexfields to define your own structure for many of the identifiers required by Oracle E-Business Suite; use descriptive flexfields to gather additional information about your business entities beyond the information required by Oracle E-Business Suite.

For more information about flexfields, see the *Oracle E-Business Suite Flexfields Guide*.

### Flexfield Mapping Concepts

Each flexfield regardless of its type has its *owner application*. For example, an Accounting Flexfield is owned by Oracle General Ledger application. During the flexfield configuration, you need to first select an application to which a flexfield belongs, and then select a *flexfield name* (such as Accounting Flexfield) contained in the

selected application (such as General Ledger).

The following diagram illustrates the high level flexfield mapping concepts for key flexfields:

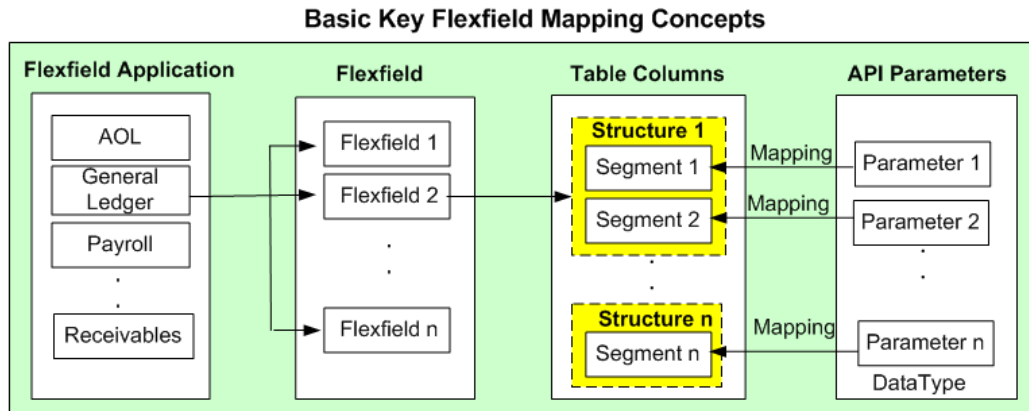

In this diagram, Flexfield 2 (Accounting Flexfield) belongs to General Ledger application, and it contains multiple segments (segment 1 to segment n) which can be grouped by data type.

The main part of flexfield configuration is *mapping*. Once a flexfield with a desired application is selected, the matching segments (segment 1 to segment n) are derived from Application Object Library (AOL) flexfield table along with the related interface parameters based on the flexfield metadata for your mapping.

API parameters are displayed based on the selected *data type* (parent type or record type). API parameters and the flexfield table columns can be mapped either manually or automatically by using Auto Map.

- **Parent type:** Parent type is a pseudo type to allow all the scalar parameters at the procedure level to participate in the mapping. It can be used for simple APIs that just have scalar parameters.
- **Record type:** Record type can be selected if it's for a complex API that has record types in addition to scalar types. When a record type occurs multiple times in the API, the list of paths is displayed for reference. If the parameters from a record type are mapped to the flexfield table columns, then the same mapping would be applicable to all the paths it occurs.

Supported record types include array, nested tables, and associated arrays.

**Note:** Automapping feature maps all the table columns to the parameters which have the column name as part of the parameter name. For examples, parameter P\_ATTRIBUTE1 would be mapped to a

column name called ATTRIBUTE1, and parameter P\_ATTRIBUTE2 would be mapped to a column name called ATTRIBUTE2.

Once mapping is completed, you will need to select a flexfield **structure** for a key flexfield.

**Note:** A flexfield structure is a specific configuration of segments. If you add or remove segments, or rearrange the order of segments in a flexfield, you get a different structure. The segments that make up a particular structure are logically or functionally related.

For descriptive flexfields, an additional mapping is required for the **context column**. All the table columns including the context column should be mapped to the scalar parameters within one record type or parent type. Once mapping is completed, select at least one context value for the selected context column for a descriptive flexfield.

For example, Chile uses 'Region' and 'Comuna' in addition to 'State' and 'County' to represent subdivision or relatively small location geographically. Similarly, Ecuador uses 'Zona' and 'Parroquia' in geography to describe different boundaries. This is a perfect example using a descriptive flexfield to customize the application to meet your business needs. Chile and Ecuador are the context values when defining the descriptive flexfield 'TCA Location Information'. Parameter1 (or Parameter2) is mapped to ATTRIBUTE1 (or ATTRIBUTE2) whose value depends on the selected context value (either 'Chile' or 'Ecuador').

**Note:** For descriptive flexfields, context value should be available to the runtime through an API parameter.

## Basic Descriptive Flexfield Mapping Concepts

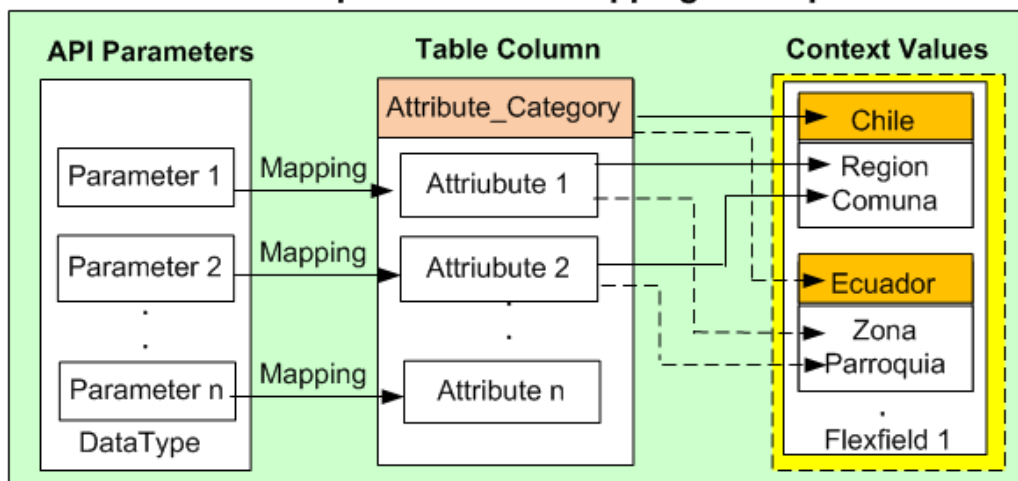

Adapter for Oracle Applications uses the flexfield mapping defined from the Application Module Browser to generate the enhanced XSD. This XSD will contain flexfield segment names based on the mapping chosen at design time. Adapter for Oracle Applications will then work in conjunction with Oracle Database Adapter to handle the enhanced schema file for runtime processing.

### Guidelines for Defining Flexfield Structure and Context Values

You will not be able to select a context value for a descriptive flexfield or a structure for a key flexfield if one of the following conditions are met:

- A context/structure has no segments or segment mappings.  
Only context/structure values that have at least one segment can be selected.
- A context/structure has segments, but none of them matches with at least one of the table columns mapped in the mapping page.
- A context/structure has all the segments disabled in Oracle E-Business Suite.
- A context/structure itself is disabled in Oracle E-Business Suite.  
Only context/structure that is enabled will be shown in the Flexfield Subflow wizard in step 6 (Flexfield Subflow - Configure Flexfields).

Flexfield mapping will be used to generate an enhanced schema or XSD file.

### Flexfield Configuration Guidelines and Constraints

- Duplicate flexfields are not allowed. A flexfield can be mapped only once for a PL/SQL API.
- Range Key Flexfields are not supported.

- Valuesets and qualifiers are not supported.
- Flexfield mapping for all the flexfield segments in one flexfield should happen either at the parent level or within one record type.
- The mapping for the context column should correspond to parameters at the level at which the segments are mapped. In other words, if the descriptive flexfield segments are mapped to a selected data type (either record type or parent type), the context column mapping should also happen with the same selected data type.

## Accessing Flexfield Configuration User Interface

While creating a partner link at design time, if a selected PL/SQL interface is configured with flexfields, Application Module Browser will display flexfield information in the right pane of the browser window.

For example, a PL/SQL API SYNC\_ACCT\_ORDER can be retrieved from a search or selected from HZ\_AIA\_CUSTOM\_PKG listed under the **Other Interfaces > Custom Objects > PLSQL APIs** node. The flexfield data if configured in this API is displayed in the Oracle Application Module Browser.

### API with Flexfield Information

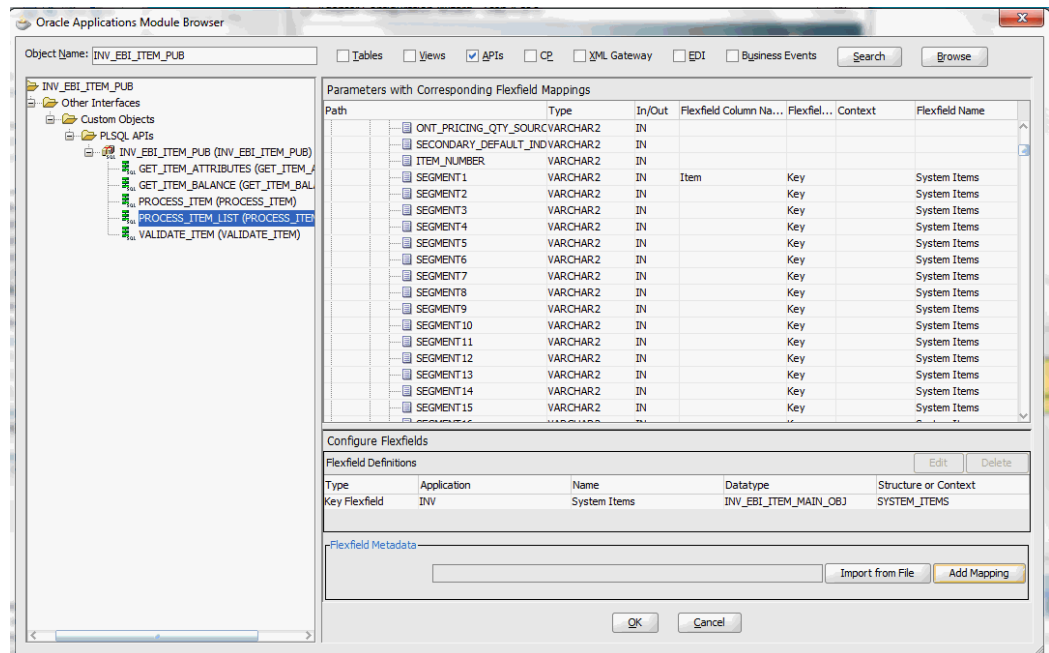

### Understanding Flexfield Data in Oracle Application Module Browser

The flexfield information associated with the selected API can be populated and configured in the following regions of the Oracle Application Module Browser:

**Note:** Alternatively, Adapter for Oracle Applications allows you to bypass the flexfield configuration or modification for your selected API by simply clicking **OK** in the browser to proceed with the partner link creation.

- **Parameters with Corresponding Flexfield Mappings Region**

This region displays the parameters of the selected API along with the corresponding API parameter to flexfield table column mapping information.

To easily locate a parameter in the selected API, record type parameters are displayed as a tree within the table.

- **Configure Flexfields Region**

This region allows you to perform the following tasks:

- *Modifying Flexfield Definitions*

No matter if the selected API is a custom or seeded one, once the flexfield mapping information is populated in the browser, you can modify context values for a descriptive flexfield and structure for a key flexfield.

Oracle Adapter for Oracle Applications will then use the flexfield definitions from Application Module Browser to generate the enhanced XSD. This XSD will contain the flexfield segment names chosen at design time based on the mapping information along with the API parameter names.

For more information on how to modify your flexfields, see *Modifying Flexfield Definitions*, page 4-77.

- *Creating a New Mapping*

You can create a new mapping for a selected API by clicking **Add Mapping** in the Flexfield Metadata section. A new flexfield mapping wizard appears guiding you through each configuration page where you can add key and descriptive flexfields, as well as configure flexfield mapping between the selected API and any flexfields defined in the Oracle E-Business Suite instance.

See: *Adding or Configuring a New Custom Mapping*, page 4-29.

- *Importing an Existing Mapping*

Instead of creating a new mapping, you can use an existing mapping that has been created earlier by clicking **Import from File** in the Flexfield Metadata section. This lets you select a desired flexfield mapping for your selected API.

Once a desired mapping is imported, you can modify the context values for a descriptive flexfield and structure for a key flexfield if needed to meet your needs.

See: Importing an Existing Flexfield Mapping, page 4-73.

### **Reviewing Flexfield Configuration Files**

Once a partner link is created, an enhanced XSD file along with flexfield configuration and mapping files are generated. You can review these files for flexfield details. See: Reviewing Flexfield Configurations, page 4-80.

## **Adding or Configuring a New Mapping**

After performing a search or browsing through the list of APIs available in Oracle Application Module Browser, if a selected PL/SQL interface is configured with flexfields, then flexfield information in the API will be displayed in the right pane of the window.

To add or configure a new mapping for the selected API, click **Add Mapping** in the Configure Flexfields region. A series of flexfield selection pages in the wizard appear guiding you to configure a new mapping for your selected API.

### Flexfield Subflow - Welcome

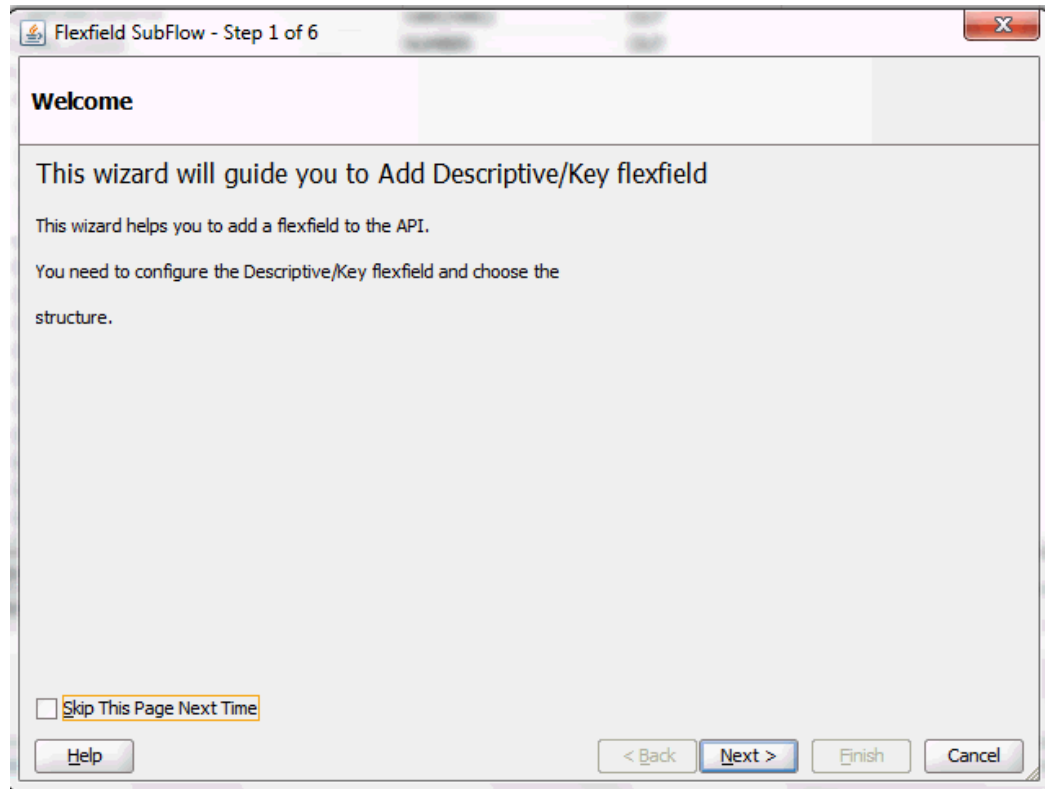

After clicking **Next** in the Welcome page, the Select Flexfield Type page appears where you can choose either a key or descriptive flexfield to be configured or added for your flexfield.



### Flexfield Subflow - Select Flexfield Type

Flexfield SubFlow - Step 2 of 6

#### Select Flexfield Type

Select the flexfield type and click next to create/edit and configure the flexfield

Type of Flexfield  Key Flexfield  
 Descriptive Flexfield

Help < Back Next > Finish Cancel

Select either the Key Flexfield or Descriptive Flexfield radio button for your flexfield configuration.

Please note that you can configure more than one key or descriptive flexfield for the selected API to meet your business needs.

See:

- Configuring Key Flexfields, page 4-31
- Configuring Descriptive Flexfields, page 4-52

## Configuring Key Flexfields

### Sample Business Scenario

Take the `INV_EBI_ITEM_PUB.PROCESS_ITEM_LIST` API as an example to explain the inbound web service creation with flexfield data.

When a request is placed for processing inventory item list from a third party application, the key flexfield data as part of the input payload is routed and the PL/SQL API `INV_EBI_ITEM_PUB.PROCESS_ITEM_LIST` is invoked to update the item list in Oracle E-Business Suite. The updated data will be passed to the client as the response message.

The following diagram illustrates the service invocation process flow:

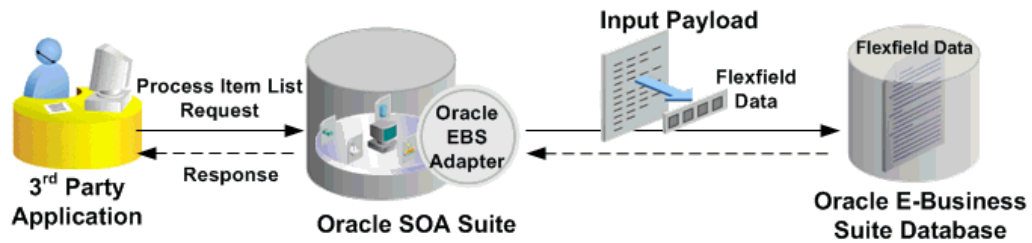

After deploying the service, you can validate the process by querying inventory item list directly from Oracle E-Business Suite application. The retrieved item data should be the same as input from the payload.

### Configuring a Key Flexfield As Part of the Partner Link Creation

To configure key flexfields for the selected API `INV_EBI_ITEM_PUB.PROCESS_ITEM_LIST`, click **Add Mapping** in the Configure Flexfields region. A series of flexfield selection pages in the wizard appear guiding you to configure a new mapping for your selected API.

Click **Next** in the Welcome page. The Select Flexfield Type page is displayed.

### Flexfield Subflow - Select Flexfield Type

Flexfield SubFlow - Step 2 of 6

#### Select Flexfield Type

Select the flexfield type and click next to create/edit and configure the flexfield

Type of Flexfield  Key Flexfield  Descriptive Flexfield

Help < Back Next > Finish Cancel

Perform the following steps to configure a key flexfield:

1. Select the **Key Flexfield** radio button in the Select Flexfield Type page. Click **Next**. The Select Flexfield Application page appears.
2. To locate your desired application name, enter keyword search (such as '%App%') and click **Query** to execute the search. All the entries that match your search criteria will be displayed. For example, select the **Inventory** radio button as the application name to which the flexfield belongs.

### Flexfield Subflow - Select Flexfield Application

Flexfield SubFlow - Step 3 of 6

#### Select Flexfield Application

Select the application to which the flexfield belongs and click next

Application: %

- Application Object Library
- Asia/Pacific Localizations
- Assets
- Capital Resource Logistics - Assets
- Common Modules-AK
- Complex Maintenance Repair and Overhaul
- E-Business Tax
- Enterprise Performance Foundation
- Financial Intelligence
- General Ledger
- Human Resources
- Inventory
- Learning Management
- Payroll
- Public Sector Budgeting
- Receivables
- Service

Alternatively, click **Query** directly to execute the blank search without keyword search. This displays all flexfield application names for your selection.

Click **Next**.

3. In the Select Flexfield page, enter keyword search if desired and click **Query** to execute the search. All the matched key flexfields are displayed for your selection. Select your desired key flexfield radio button.

### Flexfield Subflow - Select Flexfield

Flexfield SubFlow - Step 4 of 6

#### Select Flexfield

Select the flexfield and click next

Application: Inventory

Flexfield: %

- Account Aliases
- Item Catalogs
- Item Categories
- ORACLE\_SERVICE\_ITEM\_FLEXFIELD
- Sales Orders
- Stock Locators
- System Items

Click **Next** to continue.

4. The Select Datatype and Configure Mapping page appears where you can choose desired mapping for your key flexfield. Notice that your selected key flexfield name is automatically populated as the Flexfield name.

## Flexfield Subflow - Select Datatype and Configure Mapping

Application: Inventory Flexfield: System Items

Select the Datatype: INV\_EBI\_ITEM\_PUB:INV\_EBI\_ITEM\_MAIN... Paths for the datatype: P\_ITEM/P\_ITEM\$INV\_EBI\_ITEM\_OBJ\_TBL/MAIN\_O

Use parameter prefix to auto map parameter to table column  Auto Map Clear Mapping

Parameter	Table Column
SEGMENT12	SEGMENT12
SEGMENT11	SEGMENT11
SEGMENT10	SEGMENT10
SEGMENT9	SEGMENT9
SEGMENT8	SEGMENT8
SEGMENT7	SEGMENT7
SEGMENT6	SEGMENT6
SEGMENT5	SEGMENT5
SEGMENT4	SEGMENT4
SEGMENT3	SEGMENT3
SEGMENT2	SEGMENT2

Help < Back Next > Finish Cancel

To configure flexfield mapping, select the <Parent\_type> from the Select the Datatype drop-down list if it's a simple API which does not have record types. This retrieves all needed flexfield metadata from Oracle E-Business Suite database and populates parameters at the parent level for your mapping.

**Note:** Parent\_type is a pseudo type to allow all the scalar parameters at the procedure level to participate in the mapping.

You can also select record type if it's for a complex API. When a record type occurs multiple times in the API, the list of paths is displayed for reference. If the parameters from a record type are mapped to the flexfield table columns, then the same mapping would be applicable to all the paths it occurs.

In this mapping page, you have the option to do the mapping manually or use automapping feature.

- Automapping feature maps all the segments to the parameters, which have the column name as part of the parameter name. For example, table column SEGMENT1 would be mapped to parameter SEGMENT1. If there are multiple sets of parameters and the table column names, then the prefix can be specified.

For example, enter 'P\_' as the prefix to retrieve all parameters starting with 'P\_', such as P\_SEGMENT1, P\_SEGMENT2, P\_SEGMENT3, to P\_SEGMENTn where n is a number. If you click **Auto Map**, all the parameters with prefix 'P\_' are automatically displayed along with the automapped table column names.

**Note:** Flexfield values are stored in the application database tables. In general, key flexfields store their data in columns called SEGMENTn and descriptive flexfields store their data in columns called ATTRIBUTEn, where n is a number.

- Manual mapping lets you select a desired table column for a corresponding parameter.

**Note:** If a parameter has already mapped to a table column, you cannot remap the parameter to other column. In this situation, 'Already Mapped' appears instead for the mapped parameter.

Click **Clear Mapping** to clear current mapping you have. All previously mapped columns marked with 'Already Mapped' will not be removed from the system.

Click **Next** to continue.

5. The configuration of the flexfield will not be complete without a structure for a key flexfield and at least one context value for a descriptive flexfield.

In the Configure Flexfields page, enter keyword search if desired in the Structure field or simply click **Query** to execute a blank search. All the matched structures for the selected key flexfield are displayed.

Select only one structure (such as SYSTEM\_ITEMS).

Please note that there are certain criteria need to be met in order to have your desired structures displayed in the wizard for selection. See: Guidelines for Defining Flexfield Structure and Context Values, page 4-26.

### Flexfield Subflow - Configure Flexfields

Flexfield SubFlow - Step 6 of 6

#### Configure Flexfields

Select the Structure or Context and click next

Application: Inventory

Flexfield Name: System Items

Structure : %

SYSTEM\_ITEMS

**Note:** Only one structure for a key flexfield can participate in flexfield mapping. In the case of a descriptive flexfield, multiple context values can participate in the mapping.

Click **Finish**.

6. The Application Module Browser window appears. The newly added key flexfield structure and mapped parameters are displayed in the Parameters with Corresponding Flexfield Mappings region.

The key flexfield information is also displayed in the Flexfield Definitions section.



## Displaying Selected Key Flexfield Information

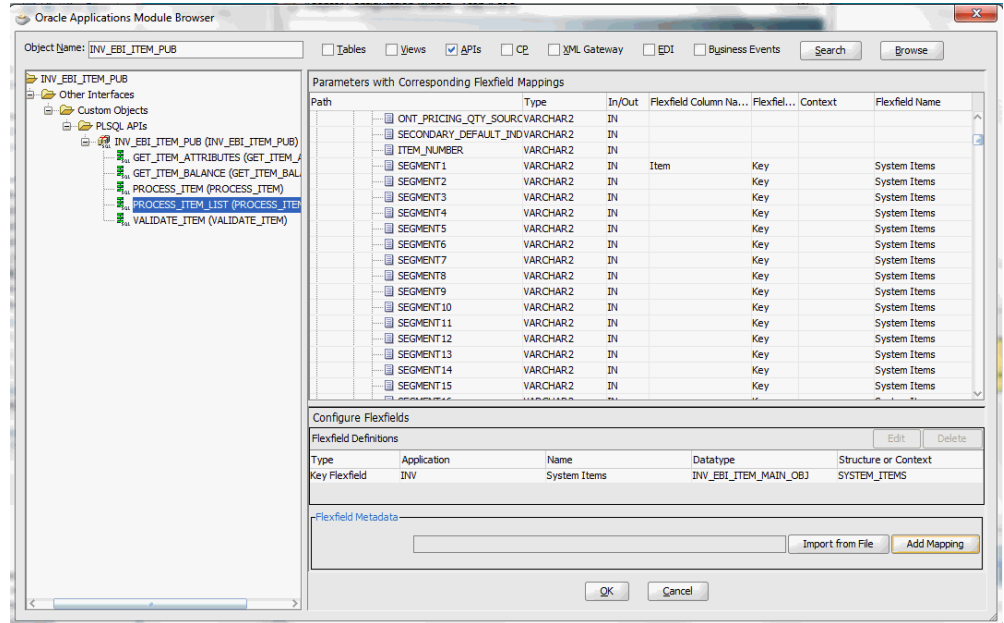

Click **OK**.

7. The Application Interface page appears with the selected API.

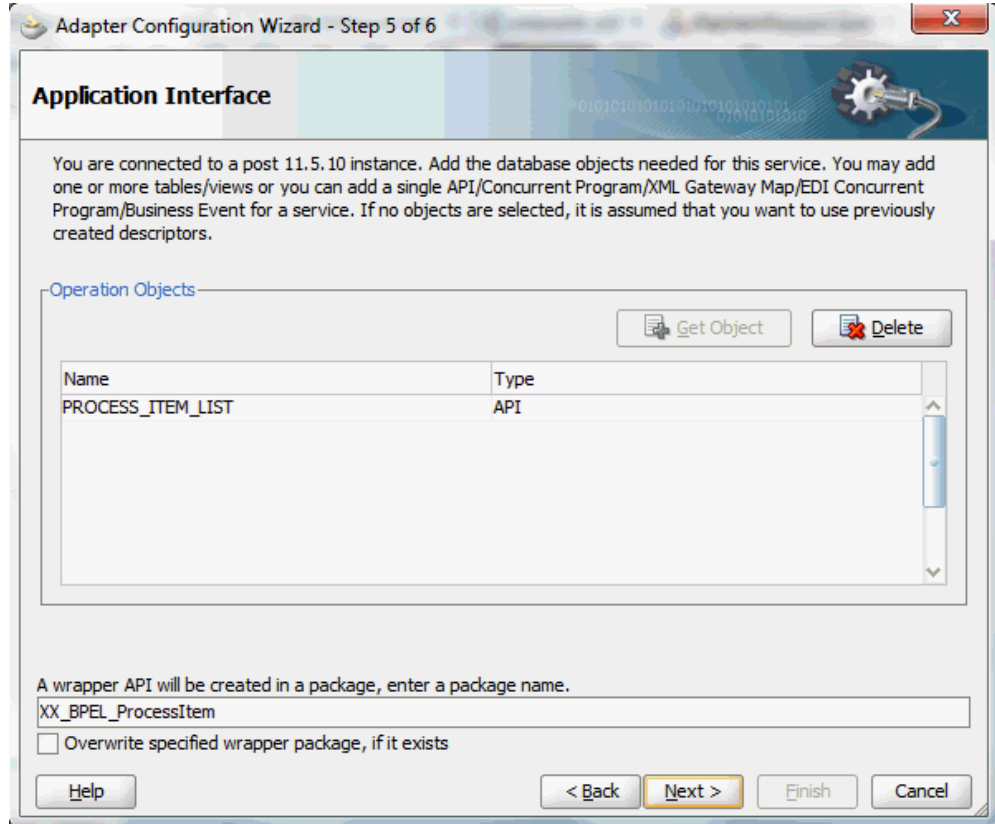

Click **Next** and then click **Finish**.

The wizard generates the WSDL file corresponding to the partner link. An enhanced XSD file, for example `ProcessItem_KFF_flex.xsd`, is also created. This XSD file contains the schema describing the procedure arguments with the elements representing the parameters that have been replaced with flexfield segment names.

Click **Apply** and then **OK**.

8. Additionally, configuration file and flexfield mapping file are created. For more information on these files, see *Reviewing Flexfield Configurations*, page 4-80.

To add descriptive flexfields for the selected API, see *Configuring Descriptive Flexfields*, page 4-52.

### Displaying Mapped Key Flexfields at Design Time

The key flexfield mapping data configured earlier during the partner link creation can be shown at design time.

### A Composite Example with Key Flexfields

Here is an example describing the key flexfield mapping in the BPEL process of a SOA composite:

- Create a new SOA composite application with BPEL process
- Add a partner link service called `ProcessItem_KFF` with key flexfield mapping that we configured earlier for the `INV_EBI_ITEM_PUB.PROCESS_ITEM_LIST` API

For information on how to configure key flexfields, see *Configuring Key Flexfields*, page 4-31.

- Add a partner link for File Adapter to read input payload that contains flexfield data for service invocation
  - In the File Directories dialog, enter the physical directory (such as `/usr/tmp`) where the input payload xml file (such as `input_payload.xml`) resides.
  - In the Messages dialog, select the 'browse for schema file' icon next to the URL field to open the Type Chooser.

Click Type Explorer and select **Project Schema Files > ProcessItem\_KFF\_sp.xsd > ProcessItem\_KFF\_flex.xsd > InputParameters**.

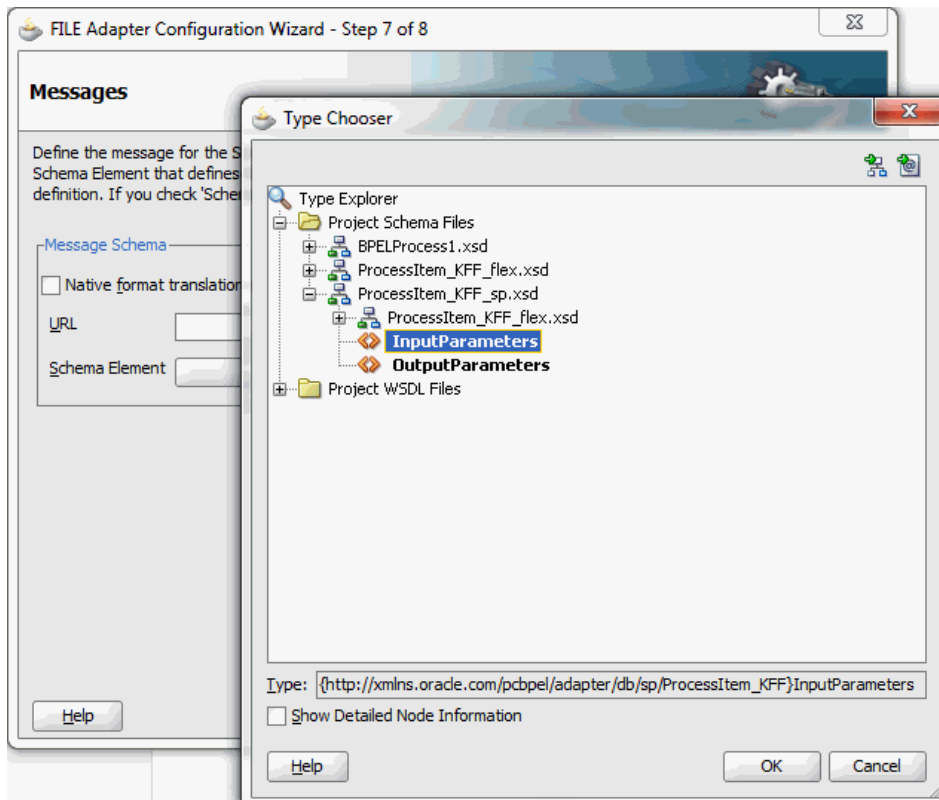

Click **OK**. The selected schema information will be automatically populated in the URL and Schema Element fields.

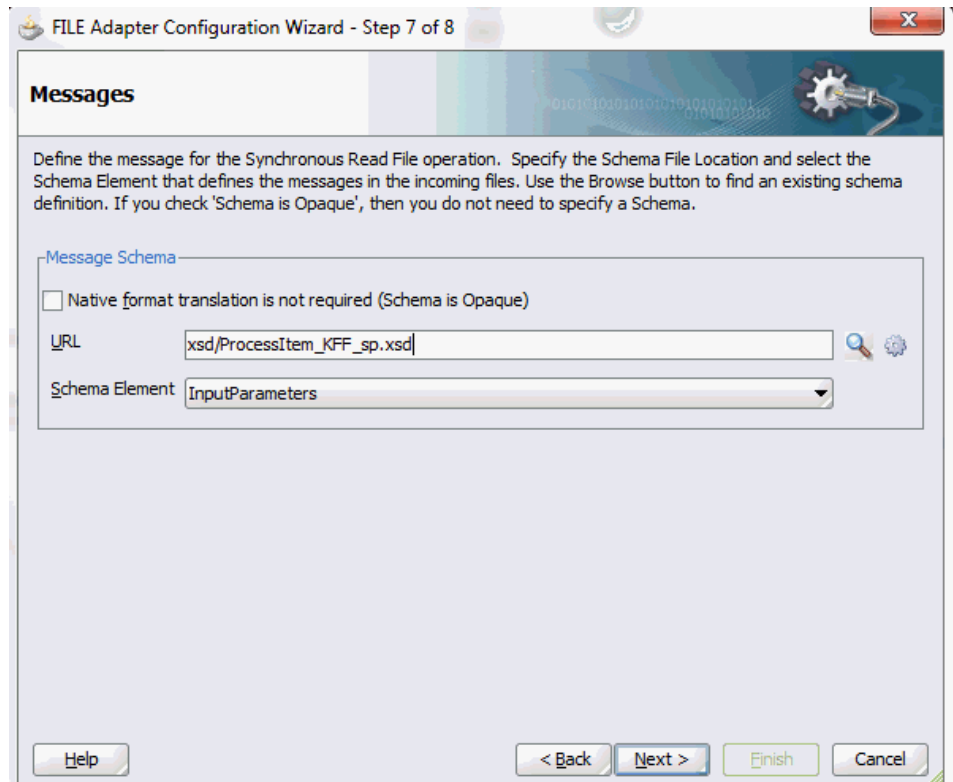

- Configure two **Invoke** activities
  - Associate the first **Invoke** activity with the File Adapter partner link to synchronously read input payload data
  - Associate the second **Invoke** activity with the partner link `ProcessItem_KFF` that contains flexfield mapping to invoke the service
- Add an **Assign** activity to pass input payload received from the File Adapter to the second **Invoke** activity for service invocation

Mapped key flexfield column names corresponding to the flexfield matching segments defined in the Oracle E-Business Suite are displayed in the **Assign** activity. See: Assigning Parameters with Key Flexfields in the Assign Activity, page 4-47.

### Constructing BPEL Process in SOA Composite

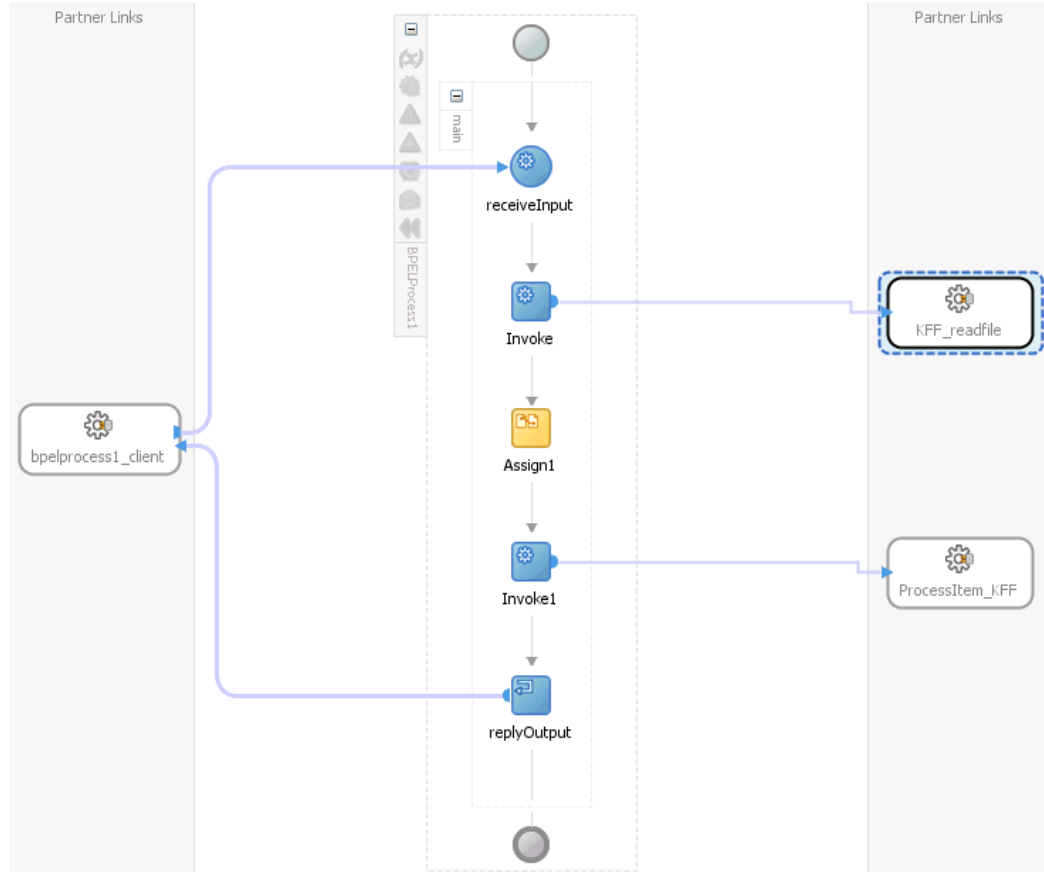

For more information on how to create design time tasks, see Design-Time Tasks for PL/SQL APIs, page 9-2.

### Flexfield Validation in Oracle E-Business Suite

When defining key flexfield segments for a key flexfield 'System Items' in Oracle Inventory application (Application Developer responsibility), only SEGMENT1 is specified as 'Item' in the Segments Summary - System Items window.

**Key Flexfield Segments Summary for System Items**

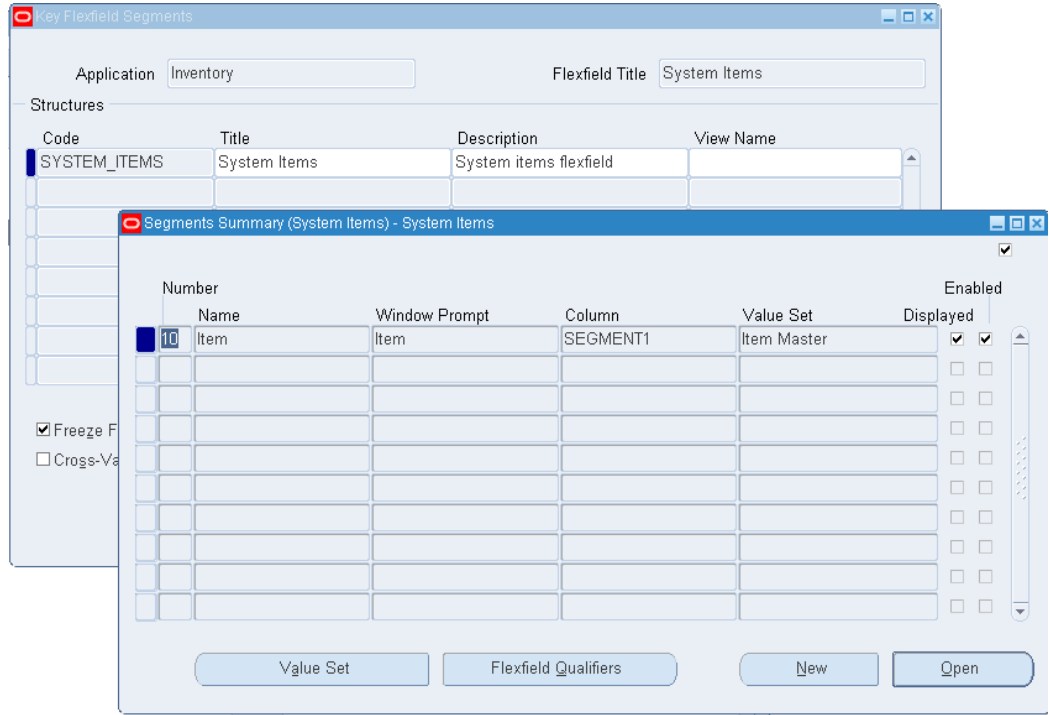

The following table explains the relationship between the key flexfield mapping data and the actual segments defined in Oracle E-Business Suite:

**Segment Summary for Key Flexfield 'System Items'**

Key Flexfield Segments Mapped During Flexfield Configuration	Key Flexfield Segments Defined in Oracle E-Business Suite
SEGMENT1	Item
SEGMENT2	Not defined
SEGMENTn	Not defined

Mapped segment column names for the key flexfield 'System Items' are displayed in the Oracle Application Module Browser once the mapping is complete. In this case, only 'Item', the corresponding column name in SEGMENT1, is shown here.

## Displaying Mapped Segment Column Name 'Item'

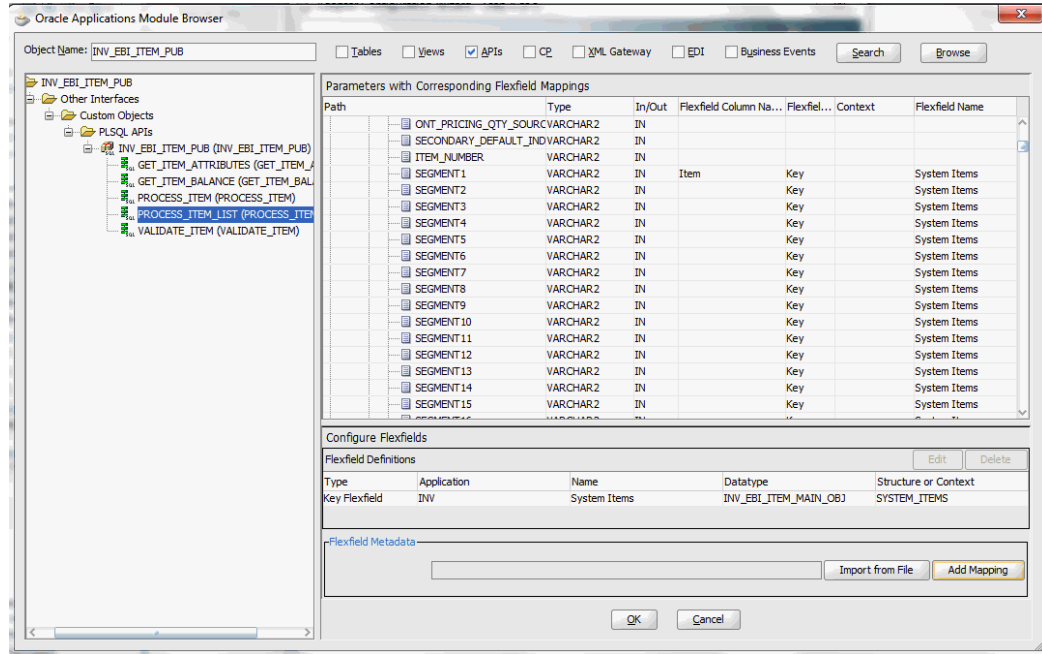

For information on how to define key flexfields and key flexfield segments, refer to the Planning and Defining Key Flexfields chapter, *Oracle E-Business Suite Flexfields Guide*.

### Flexfield Validation in the Schema File

Select the enhanced XSD file (for example `ProcessItem_KFF_flex.xsd`) in Oracle JDeveloper and notice that the mapped key flexfield column (Item) is displayed with type 'flex' under the flexfield name System\_Items.



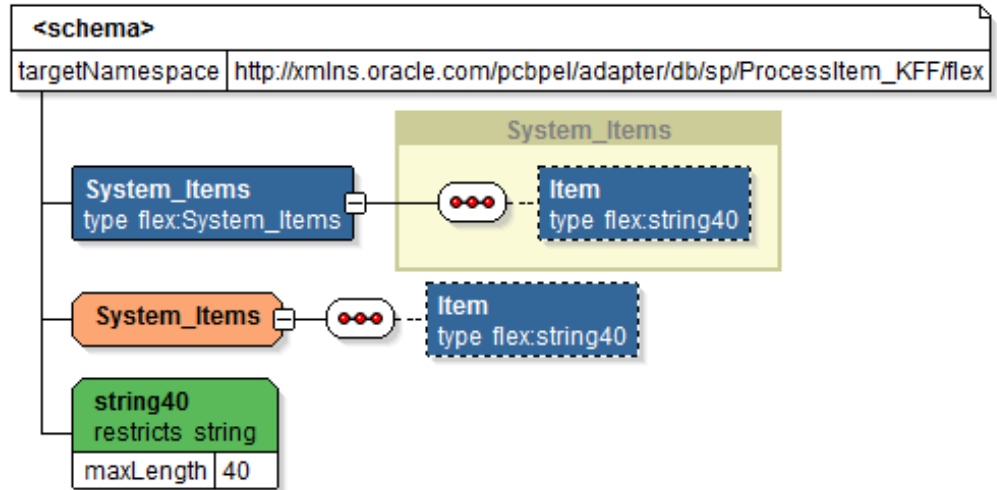

### Assigning Parameters with Key Flexfields in the Assign Activity

In the **Assign** activity of the BPEL process diagram within the SOA composite application, the mapped key flexfield can be displayed and used to pass an input variable from payload to the second **Invoke** activity for service invocation.

## Displaying Mapped Key Flexfields in the Assign Activity

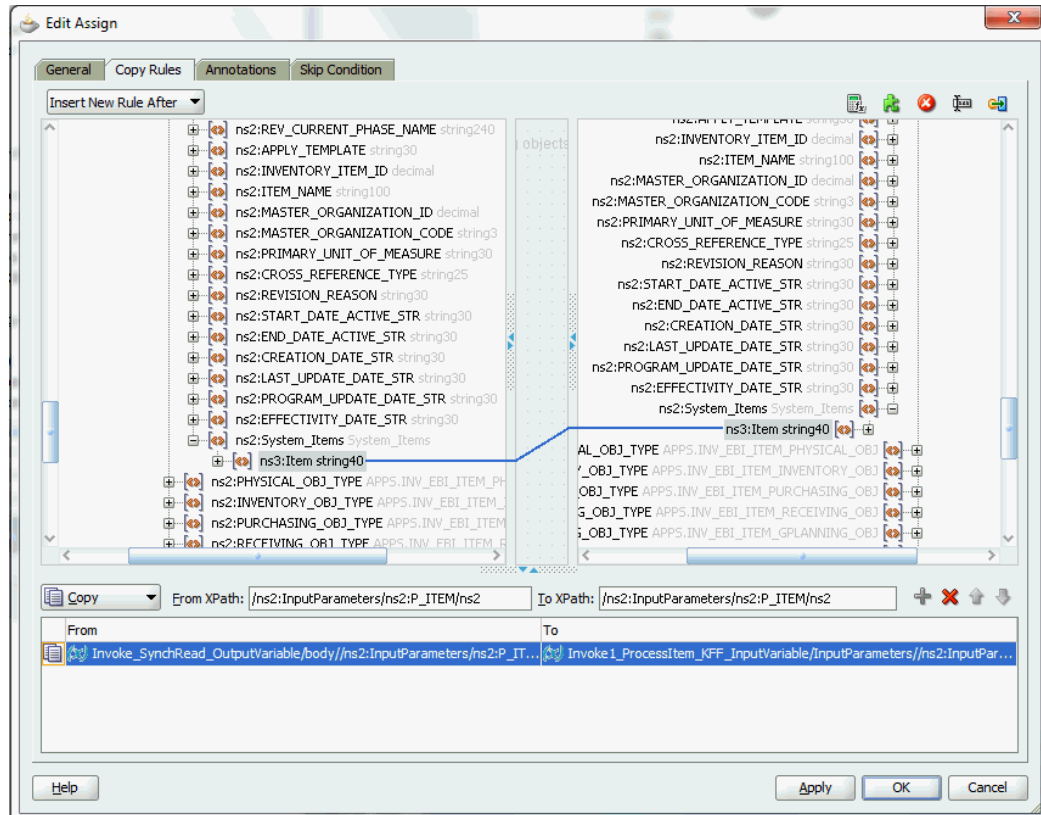

Use **Assign** activity to provide input payload information to the Item object of the target parameter.

**Note:** The target parameter `ns2:SEGMENT1` mapped to the column name `SEGMENT1` during the key flexfield configuration earlier is now translated into `ns3:Item` (under `ns2:System_Items`) and displayed in the **Assign** activity.

- In the From navigation tree, navigate to **Variables > Process > Variables > Invoke\_SynchRead\_OutputVariable > body > ns2:InputParameters > ns2:P\_ITEM > ns2:P\_ITEM\_ITEM > ns2:MAIN\_OBJ\_TYPE** (datatype `INV_EBI_ITEM_MAIN_OBJ`) > `ns2: System_Items` and select `ns3: Item`.
- In the To navigation tree, navigate to **Variables > Process > Variables > Invoke1\_ProcessItem\_KFF\_InputVariable > InputParameters > ns2:InputParameters > ns2:P\_ITEM > ns2:P\_ITEM\_ITEM > ns2:MAIN\_OBJ\_TYPE** (datatype `INV_EBI_ITEM_MAIN_OBJ`) > `ns2: System_Items` and select `ns3: Item`.

Drag the source node (`ns3: Item`) to connect to the target node (`ns3: Item`) that you just specified. This creates a line that connects the source and target nodes. The copy rule is

displayed in the From and To sections at the bottom of the Edit Assign dialog box. Click **Apply** and **OK** to complete the **Assign** activity.

**Note:** Alternatively, since 'ns2:InputParameters' variables contained in the Source and Target are identical, you can simply drag the source node (ns2:InputParameters) to connect to the target node (ns2:InputParameters) and complete the **Assign** activity.

### Assigning Input Variables to the Invoke Activity

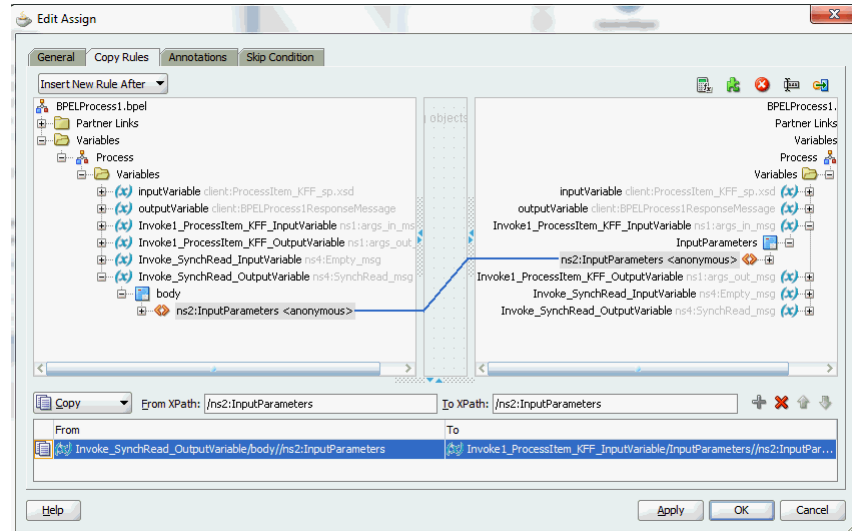

Please note that the datatype INV\_EBI\_ITEM\_MAIN\_OBJ shown here is exact the same datatype (INV\_EBI\_ITEM\_PUB:INV\_EBI\_ITEM\_MAIN\_OBJ) specified earlier from the drop-down list in the Select Datatype and Configure Mapping page. P\_ITEM is listed as the paths for the selected datatype.

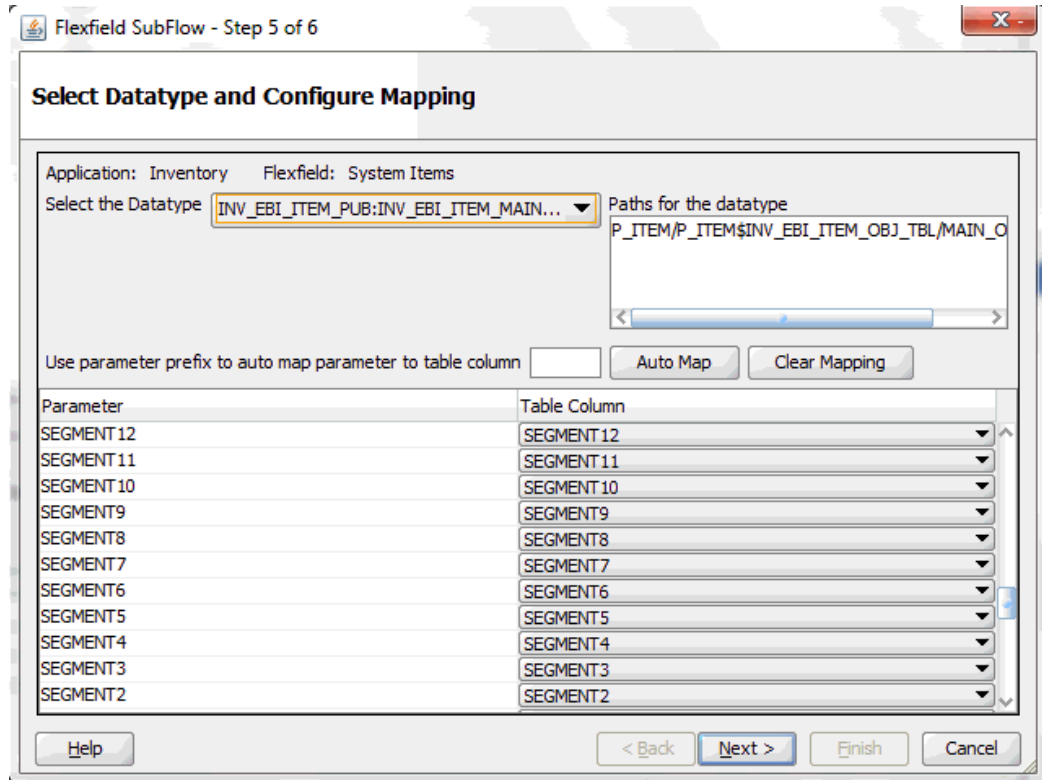

### Displaying Mapped Key Flexfields at Runtime

After deploying the BPEL process contained in a SOA Composite application (FlexfieldKFF) to the Oracle WebLogic managed server (for example 'soa-server1'), the key flexfields we configured earlier are displayed in the soa-server1 server (<http://<servername>:<portnumber>/soa-infra>) allowing you to specify payload data and test the service invocation.

**Note:** Please note that you can also test and manage the process from the Oracle Enterprise Manager Fusion Middleware Control Console. In this example, the mapped key flexfield used as part of the input payload happens to be located or nested within multiple sub-levels down from the top. This means that we need to drill down to the mapped key flexfield `Item` by expanding the parameter nodes multiple times from the top level (Payload > P\_ITEM > P\_ITEM\_ITEM > MAIN\_OBJ\_TYPE > System\_Items > Item). However, Oracle Enterprise Manager Fusion Middleware Control Console has certain limitations on displaying payload parameters if they are nested too deeply.

Request			Response
>	Security		
>	Quality of Service		
>	HTTP Transport Options		
>	Additional Test Options		
>	Input Arguments		
Tree View			
Name	Type	Value	
∇ * payload	payload		
P_COMMIT	string	<input type="text"/>	
P_OPERATION	string	<input type="text"/>	
∇ P_ITEM	APPS.INV_EBI_ITEM_OBJ_TBL		
P_ITEM_ITEM	APPS.INV_EBI_ITEM_OBJArray Siz...		

Therefore, in this case we access the mapped key flexfield directly from the `soa-infra` in the `soa-server1` server.

For information on how to test the service invocation from the Oracle Enterprise Manager Fusion Middleware Control Console, see [Test the deployed SOA Composite application with BPEL process](#), page 9-49.

## Welcome to the Oracle SOA/BPM Platform on WebLogic

SOA Version: v11.1.1.7.0 - 11.1.1.7.0\_130123.2000.0834 built on Thu Jan 24 01:40:20 PST 2013  
 WebLogic Server 10.3.6.0 Tue Nov 15 08:52:36 PST 2011 1441050 (10.3.6.0)

The following composites are currently deployed:

1. default/DescFlex!2.0\*soa\_3847c4b0-4615-4cc8-b3b1-5b887a97c3be
  - o [Test bpelprocess1\\_client\\_ep](#)
2. default/FlexfieldKFF!1.0\*soa\_8a41e514-1c36-42bd-a12f-117bebeb258b
  - o [Test bpelprocess2\\_client\\_ep](#)

Click the FlexfieldKFF project (the 'Test\_bpelprocess2\_client\_ep' link) to display the payload information in HTML:

For a formal definition, please review the [Service Description](#).

Download the JavaScript Stub (BETA) for [BPPELProcess2\\_pt](#) and see its [documentation](#).

A list of all imported WSDL and Schema documents may be found [here](#)

### BPPELProcess2\_pt

Operation: PROCESS  HTML Form  XML Source

WS-Security Sent In Header (optional)

payload

P\_COMMIT  xsd:string  Include In Message

P\_OPERATION  xsd:string  Include In Message

P\_ITEM  Include In Message

P\_ITEM\_ITEM  Include In Message

MAIN\_OBJ\_TYPE  Include In Message

Note: XML source view contents will not be reflected in the HTML form view

Show Transport Info

Perform stress test  Enable

In the Payload section, expand the P\_ITEM > P\_ITEM\_ITEM > MAIN\_OBJ\_TYPE > System\_Items. Mapped key flexfield 'Item' is displayed as part of the payload.

EFFECTIVITY\_DATE\_STR  xsd:string  Include In Message

System\_Items  Include In Message

**Key Flexfield** →  Item  xsd:string  Include In Message

PHYSICAL\_OBJ\_TYPE  Include In Message

Enter appropriate data as payload and then click **Invoke** to invoke the service.

## Configuring Descriptive Flexfields

### Sample Business Scenario

Take the HZ\_AIA\_CUSTOM\_PKG.SYNC\_ACCT\_ORDER API as an example to explain the inbound web service creation with flexfield data.

When a request is placed for synchronizing customer information from a third party application, the descriptive flexfield data as part of the payload is routed and the PL/SQL API HZ\_AIA\_CUSTOM\_PKG.SYNC\_ACCT\_ORDER is invoked to update the organization and customer accounts in Oracle E-Business Suite. The synchronized customer data will be passed to the client as the response message.

The following diagram illustrates the service invocation process flow:

### **Invoking an Inbound Service with Flexfield Data**

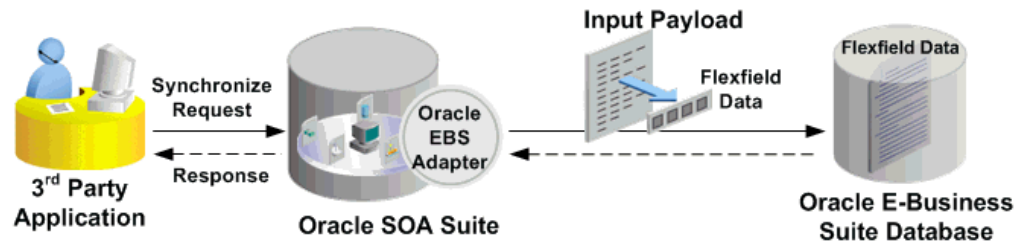

After deploying the service, you can validate the process by querying customer data directly from Oracle Customer Online application. The retrieved customer data should be the same as input from the payload.

### **Configuring a Descriptive Flexfield As Part of the Partner Link Creation**

To configure descriptive flexfields for the selected API

`HZ_AIA_CUSTOM_PKG.SYNC_ACCT_ORDER`, click **Add Mapping** in the Configure Flexfields region. A series of flexfield selection pages in the wizard appear guiding you to configure a new mapping for your selected API.

Click **Next** in the Welcome page. The Select Flexfield Type page is displayed.

### Flexfield Subflow - Select Flexfield Type

Flexfield SubFlow - Step 2 of 6

#### Select Flexfield Type

Select the flexfield type and click next to create/edit and configure the flexfield

Type of Flexfield

Key Flexfield

Descriptive Flexfield

Help < Back Next > Finish Cancel

Perform the following steps to configure a descriptive flexfield:

1. Select the **Descriptive Flexfield** radio button in the Select Flexfield Type page, and then use the similar approach as described earlier for key flexfields in the flexfield mapping wizard.
2. Click **Next** in the Select Flexfield Type page. The Select Flexfield Application page is displayed.
3. To locate your desired application, enter keyword search (such as '%App%') or simply click **Query** to execute the search. All the matched applications for descriptive flexfield are displayed. For example, select the **Receivables** radio button as the application name to which the descriptive flexfield belongs.



### Flexfield Subflow - Select Flexfield Application

Flexfield SubFlow - Step 3 of 6

#### Select Flexfield Application

Select the application to which the flexfield belongs and click next

Application: %

- Public Sector Payroll
- Purchasing
- Purchasing Intelligence
- Quality
- Receivables
- Regional Localizations
- Release Management
- Release Management Integration Kit (Obsolete)
- Report Manager
- Risk Management
- SEM Exchange (obsolete)
- SSP
- Sales
- Sales Foundation
- Sales Intelligence
- Sales Offline
- Sales Online

Click **Next**.

4. In the Select Flexfield page, enter keyword search (such as 'HZ%') if desired and click **Query** to execute the search. All the matched descriptive flexfields are displayed for your selection.

Select your desired descriptive flexfield (such as HZ\_LOCATIONS) and click **Next**.

### Flexfield Subflow - Select Flexfield

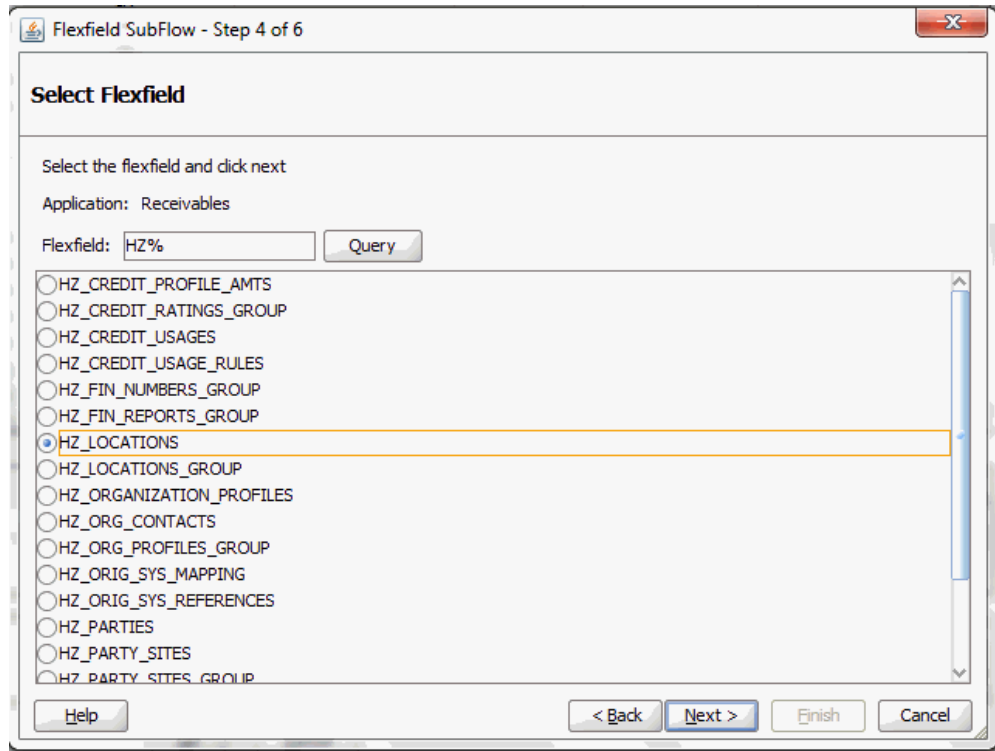

5. The Select Datatype and Configure Mapping page appears where you can choose desired mapping for your descriptive flexfield.

Notice that your selected descriptive flexfield name HZ\_LOCATIONS is automatically populated as the Flexfield name.

### Flexfield Subflow - Select Path and Configure Mapping

Flexfield SubFlow - Step 5 of 6

#### Select Datatype and Configure Mapping

Application: Receivables Flexfield: HZ\_LOCATIONS

Select the Datatype: HZ\_AIA\_CUSTOM\_PKG:HZ\_LOCATION\_OBJ

Paths for the datatype:

- P\_ORG\_CUST\_OBJ/ORGANIZATION\_OBJ/CONT...
- P\_ORG\_CUST\_OBJ/ORGANIZATION\_OBJ/PARTY...
- X\_RETURN\_OBJ/ORGANIZATION\_OBJ/CONTAC...
- X\_RETURN\_OBJ/ORGANIZATION\_OBJ/PARTY...

Map Context Column: ATTRIBUTE\_CATEGORY

Use parameter prefix to auto map parameter to table column:  Auto Map Clear Mapping

Parameter	Table Column
ATTRIBUTE9	ATTRIBUTE9
ATTRIBUTE8	ATTRIBUTE8
ATTRIBUTE7	ATTRIBUTE7
ATTRIBUTE6	ATTRIBUTE6
ATTRIBUTE5	ATTRIBUTE5
ATTRIBUTE4	ATTRIBUTE4
ATTRIBUTE3	ATTRIBUTE3
ATTRIBUTE2	ATTRIBUTE2
ATTRIBUTE1	ATTRIBUTE1

Help < Back Next > Finish Cancel

To configure flexfield mapping, select a desired data type from the Datatype drop-down list. This retrieves all needed flexfield metadata from Oracle E-Business Suite database and populates parameters at the parent level for your mapping.

- **Parent type:** Parent type is a pseudo type to allow all the scalar parameters at the procedure level to participate in the mapping. It can be used for simple APIs that just have scalar parameters.
- **Record type:** Record type can be selected if it's a complex API that has record types in addition to scalar types.

### Selecting Context Column for Descriptive Flexfield Mapping

For descriptive flexfields, you need to perform an additional mapping for the context column. This is because flexfield mapping cannot span across record types. All the table columns including the context column should be mapped to the scalar parameters within one record type or parent type.

In the Map Context Column ATTRIBUTE\_CATEGORY field, select a desired category name that you want to view the mapping information from the drop-down list. For example, select ATTRIBUTE\_CATEGORY from the drop-down list.

**Note:** If a parameter has already mapped to a table column, you cannot remap the parameter to other column. In this situation, 'Already Mapped' appears instead for the mapped parameter.

Similar to key flexfields, the mapping can be performed manually or assisted with the automapping feature by clicking **Auto Map**.

Automapping feature maps all the table columns to the parameters, which have the column name as part of the parameter name. For example, table column names from ATTRIBUTE1 to ATTRIBUTE20 are automatically displayed and mapped to parameters from ATTRIBUTE1 to ATTRIBUTE20 respectively through automapping.

If there are multiple sets of parameters and the table column names, then the prefix needs to be specified for automapping. This would map the potential parameters which need to be considered for the mapping. Enter parameter prefix (such as 'INDUSTRY\_') to first locate your desired parameters that you want the automapping to be performed. Next, click **Auto Map**. All the parameters with prefix 'INDUSTRY\_' are automatically displayed along with the automapped table column names. Parameter 'INDUSTRY\_ATTRIBUTE1' is mapped to column ATTRIBUTE1, and parameter 'INDUSTRY\_ATTRIBUTE $n$ ' is mapped to column ATTRIBUTEn.

Instead of using automapping feature, you can manually select a desired table column name from the drop-down list for a corresponding parameter for your flexfield mapping.

Click **Clear Mapping** to clear current mapping you have in the table column only. All previously mapped columns marked with 'Already Mapped' will not be removed from the system.

Click **Next** to proceed to the next page.

6. In the Configure Flexfields page, select at least one context value for the selected descriptive flexfield. For example, select desired context values (such as Chile and Ecuador).

You can either enter keyword search in the Context field or simply click **Query** to execute the search before selection.

For descriptive flexfields, context value should be available to the runtime through an API parameter.

Please note that there are certain criteria need to be met in order to have your desired context values displayed in the wizard for selection. See: Guidelines for Defining Flexfield Structure and Context Values, page 4-26.

### Flexfield Subflow - Configure Flexfields

Flexfield SubFlow - Step 6 of 6

#### Configure Flexfields

Select the Structure or Context and click next

Application: Receivables  
Flexfield Name: HZ\_LOCATIONS

Context : %

- Chile
- Ecuador
- Global Data Elements

Click **Finish** to complete the flexfield configuration.

7. The Application Module Browser window appears. The newly added descriptive flexfield information including the segment values for the selected context value is displayed in the right pane of the window.

## Displaying Selected Descriptive Flexfield Information

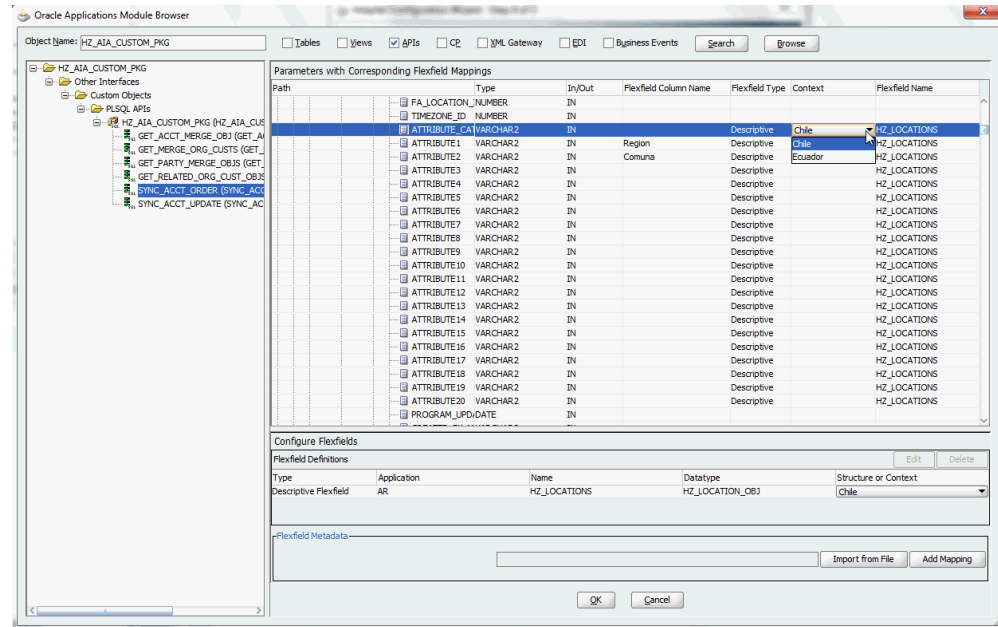

Click **OK**.

- The Application Interface page appears with the selected API.

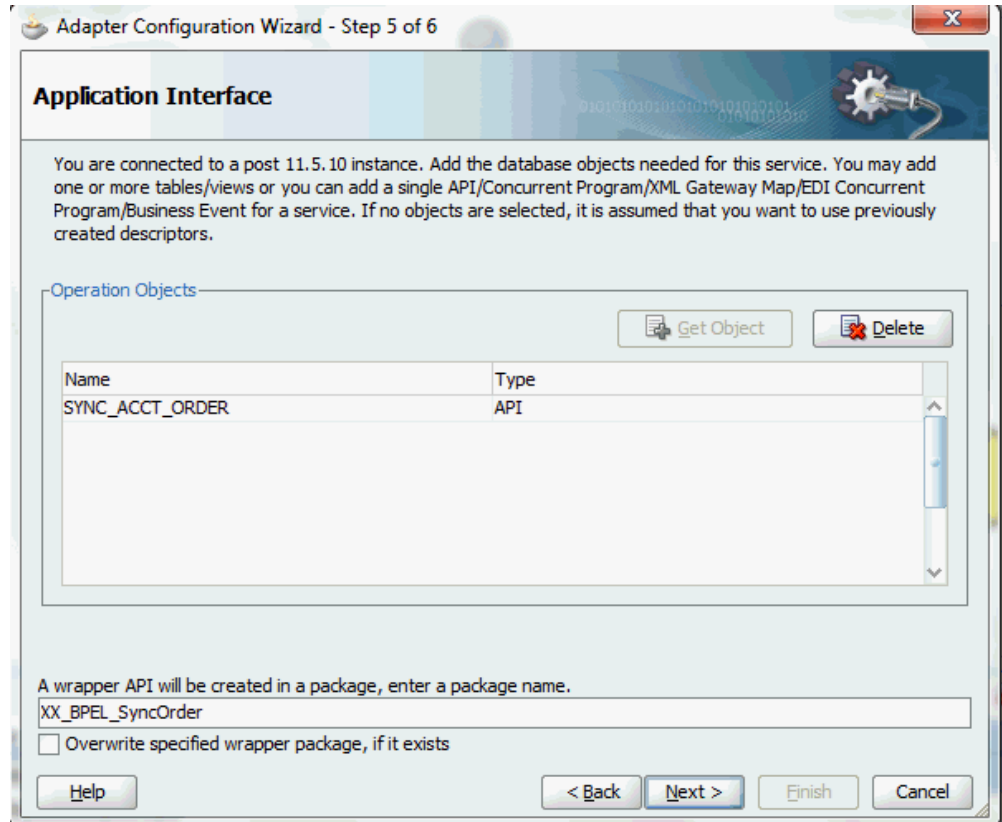

Click **Next** and then click **Finish**.

The wizard generates the WSDL file corresponding to the partner link. An enhanced XSD file, for example `SynAccOrder_flex.xsd`, is also created. This XSD file contains the schema describing the procedure arguments with the elements representing the parameters that have been replaced with flexfield segment names.

Click **Apply** and then **OK**.

9. Additionally, configuration file and flexfield mapping file are created. For more information on these files, see *Reviewing Flexfield Configurations*, page 4-80.

Once a new flexfield mapping has been configured or added, if modification is needed, you can make updates by first selecting desired flexfield type that you want to modify and then make needed changes. For more information on how to modify the selected mapping details, see *Modifying Your Flexfield Mapping*, page 4-77.

### Displaying Mapped Descriptive Flexfields at Design Time

Similar to key flexfields, the descriptive flexfield mapping data configured earlier during the partner link creation can be shown at design time along with the following activities orchestrated in the BPEL process within in a SOA composite:

#### A Composite Example with Descriptive Flexfields

Here is an example describing the descriptive flexfield mapping in the BPEL process of a SOA composite:

- Create a new SOA composite application with BPEL process
- Add a partner link service called `SynAccOrder` with descriptive flexfield mapping that we configured earlier for the `HZ_AIA_CUSTOM_PKG.SYNC_ACCT_ORDER` API  
For information on how to configure descriptive flexfields, see *Configuring Descriptive Flexfields*, page 4-52.
- Add a partner link for File Adapter to read input payload that contains flexfield data for service invocation
  - In the File Directories dialog, enter the physical directory (such as `/usr/tmp`) where the input payload xml file (such as `input_payload.xml`) resides.
  - In the Messages dialog, select the 'browse for schema file' icon next to the URL field to open the Type Chooser.  
Click Type Explorer and select **Project Schema Files > SynAccOrder\_sp.xsd > SynAccOrder\_flex.xsd > InputParameters**.



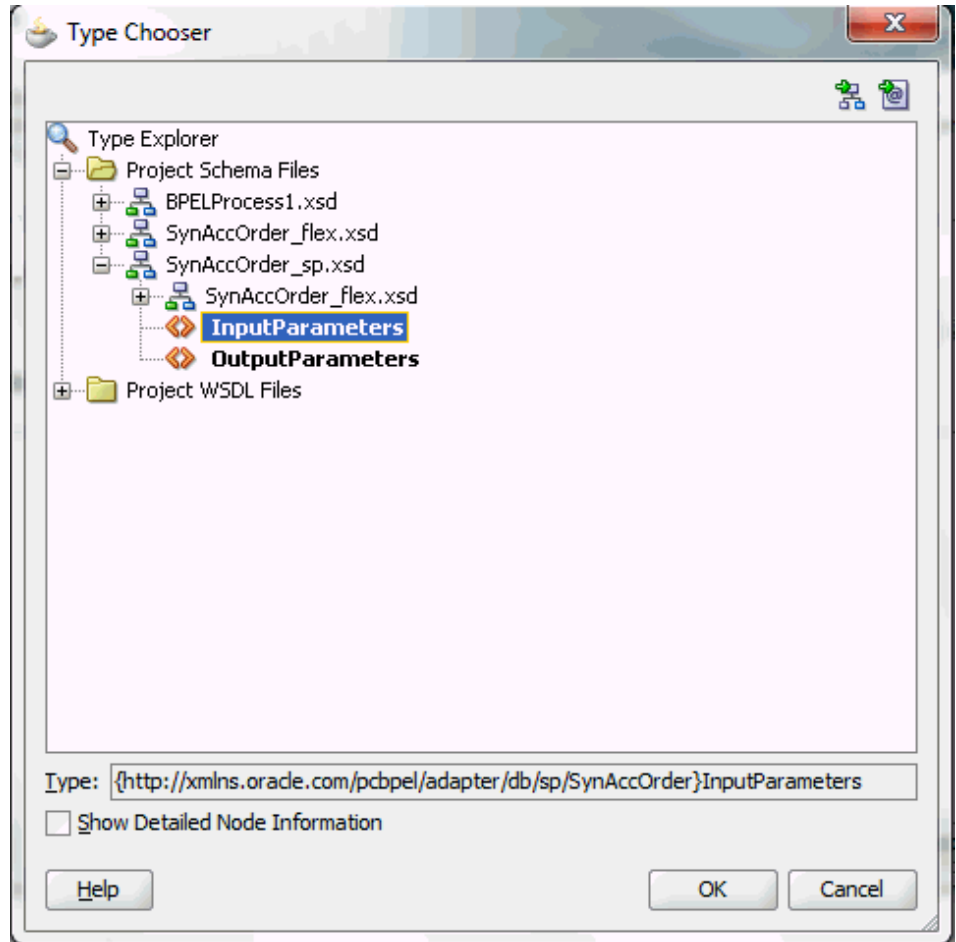

Click **OK**. The selected schema information will be automatically populated in the URL and Schema Element fields.

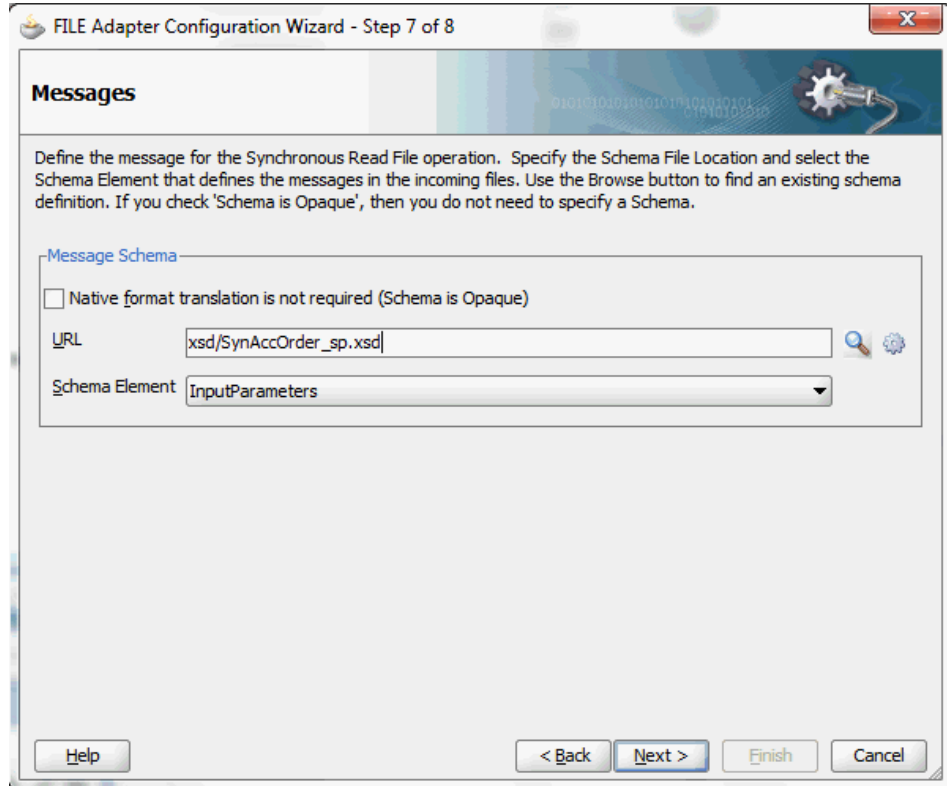

- Configure two **Invoke** activities
  - Associate the first **Invoke** activity with the File Adapter partner link to synchronously read input payload data
  - Associate the second **Invoke** activity with the partner link `SynAccOrder` that contains flexfield mapping to invoke the service.
- Add an **Assign** activity to pass input payload received from the File Adapter to the second **Invoke** activity for service invocation

Mapped descriptive flexfield column names corresponding to the flexfield matching segments defined in the Oracle E-Business Suite are displayed in the **Assign** activity. See: Assigning Parameters with Descriptive Flexfields in the Assign Activity, page 4-67.

### Constructing BPEL Process in SOA Composite

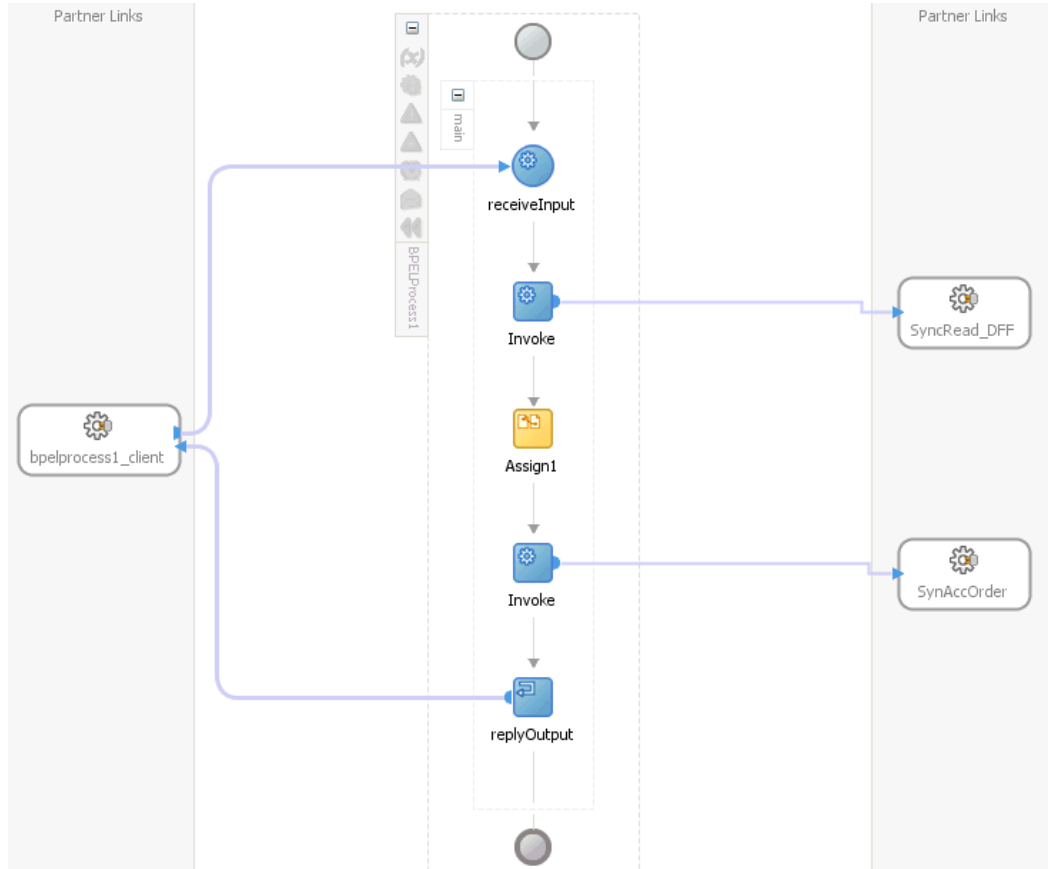

For more information on how to create design time tasks, see Design-Time Tasks for PL/SQL APIs, page 9-2.

### Flexfield Validation in Oracle E-Business Suite

When defining descriptive flexfield attributes for 'TCA Location Information' (HZ\_LOCATIONS) in Oracle Receivables application (Application Developer responsibility), the following attributes are specified based on context values:

#### ***Descriptive Flexfield Segment Summary for TCA Location Information***

<b>Context Value</b>	<b>ATTRIBUTE1</b>	<b>ATTRIBUTE2</b>
Chile	Region	Comuna
Ecuador	Zona	Parroquia

## Descriptive Flexfield Segments Summary for System Items

The screenshot displays three overlapping windows from the Oracle Flexfield configuration tool:

- Descriptive Flexfield Segments:**
  - Application: Receivables
  - Title: TCA Location Information
  - Freeze Flexfield Definition:
  - Segment Separator: Period (.)
  - Context Field:
    - Prompt: Context Value
    - Value Set: [Empty]
    - Default Value: [Empty]
    - Reference Field: [Empty]
    - Required:
    - Displayed:
    - Synchronize with Reference Field:
- Context Field Values:**

Code	Name	Description	Enabled
Global Data Elements	Global Data Elements	Global Data Element Context	<input checked="" type="checkbox"/>
Chile	Chile	Chilean Localization	<input checked="" type="checkbox"/>
Ecuador	Ecuador	Ecuadorian Localization	<input checked="" type="checkbox"/>
- Segments Summary (TCA Location Information) - Chile:**

Number	Name	Window Prompt	Column	Value Set	Enabled	Displayed
1	Region	Region	ATTRIBUTE1		<input checked="" type="checkbox"/>	<input checked="" type="checkbox"/>
2	Comuna	Comuna	ATTRIBUTE2		<input checked="" type="checkbox"/>	<input checked="" type="checkbox"/>
- Segments Summary (TCA Location Information) - Ecuador:**

Number	Name	Window Prompt	Column	Value Set	Enabled	Displayed
1	Zona	Zona	ATTRIBUTE1		<input checked="" type="checkbox"/>	<input checked="" type="checkbox"/>
2	Parroquia	Parroquia	ATTRIBUTE2		<input checked="" type="checkbox"/>	<input checked="" type="checkbox"/>

### Flexfield Validation in the Schema File

Select the enhanced XSD file (such as `SynAccOrder_flex.xsd`) in Oracle JDeveloper and notice that the mapped descriptive flexfields are displayed with type 'flex' under the `HZ_LOCATIONS` flexfield as part of the schema.

Additionally, the mapped table column names (`Region`, `Comuna`, `Zona`, and `Parroquia`) are grouped by context value (`Chile` and `Ecuador`) listed in a tree structure. Context value nodes are connected with the **<choice>** icon in between indicating that only either one of the context values and its associated table columns can be selected.

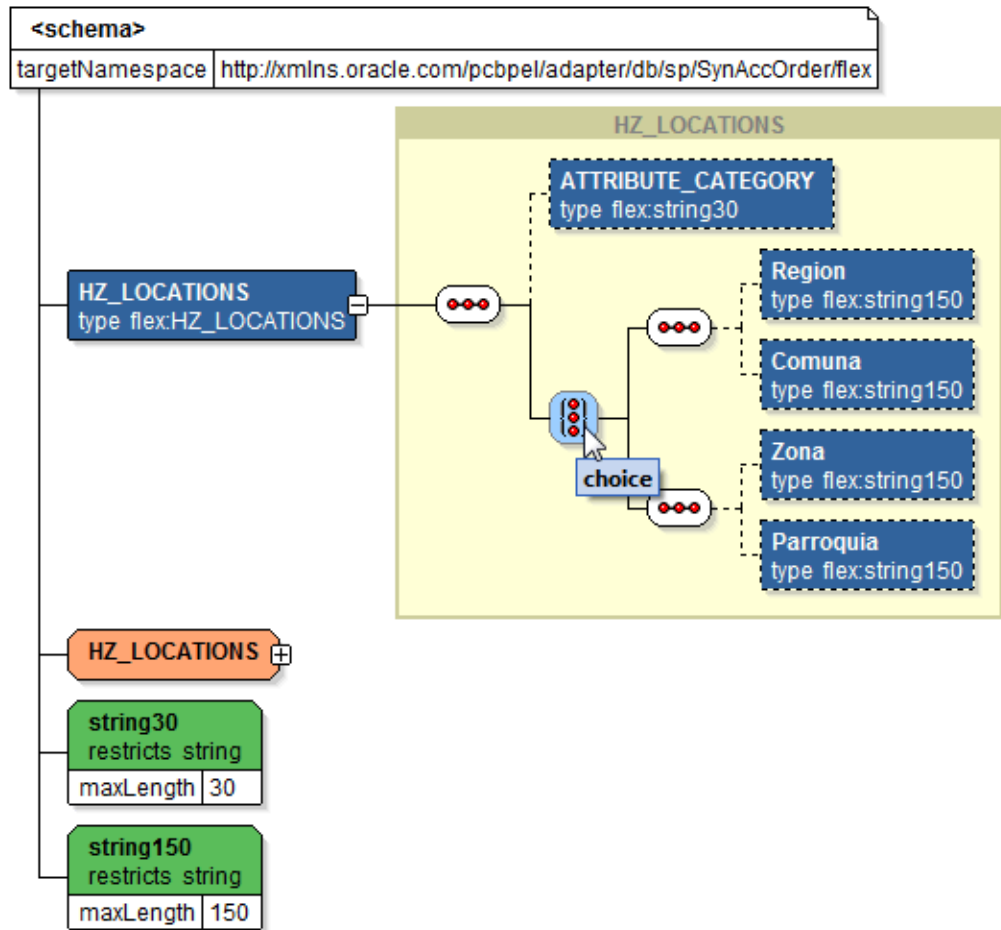

### Assigning Parameters with Descriptive Flexfields in the Assign Activity

In the **Assign** activity of the BPEL process diagram within the SOA composite application, the mapped descriptive flexfields can be displayed and used to pass an input variable received from payload to the **Invoke** activity for *SynAccOrder* service invocation.

## Mapped Descriptive Flexfields Displayed in the Assign Activity

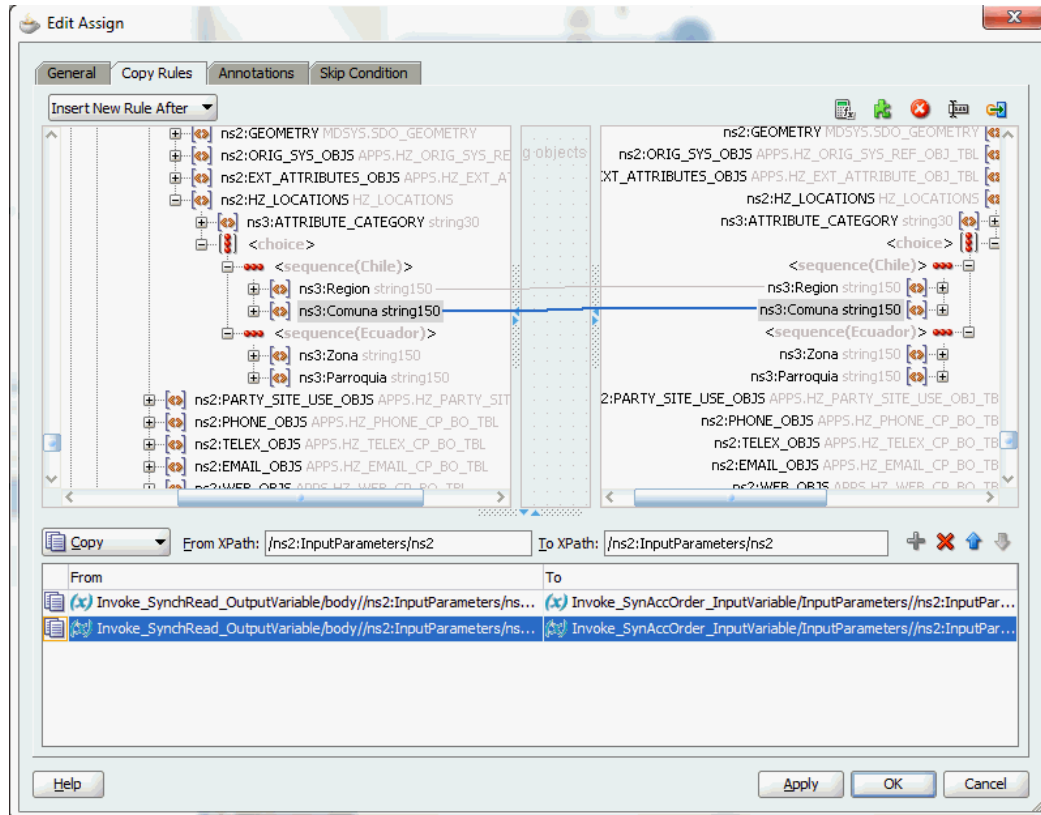

Use **Assign** activity to provide input payload information to the TCA Location object of the target parameter.

The target parameters `ns2 : ATTRIBUTE1` was mapped to the following descriptive flexfield columns during the flexfield configuration earlier:

- Region (under context value `<sequence (Chile)>`)
- Zona (under context value `<sequence (Ecuador)>`)

The target parameters `ns2 : ATTRIBUTE2` was mapped to the following descriptive flexfield columns during the flexfield configuration earlier:

- Comuna (under context value `<sequence (Chile)>`)
- Parroquia (under context value `<sequence (Ecuador)>`)

These descriptive flexfield columns grouped by context value are displayed in the **Assign** activity.

- In the From navigation tree, navigate to **Variables > Process > Variables > Invoke\_SynchRead\_OutputVariable > body > ns2:InputParameters >**

ns2:P\_ORG\_CUST\_OBJ > ns2:ORGANIZATION\_OBJ > ns2:PARTY\_SITE\_OBJS > ns2:PARTY\_SITE\_OBJS\_ITEM > ns2:LOCATION\_OBJ > ns2:HZ\_LOCATIONS > ns3:ATTRIBUTE\_CATEGORY and expand the <choice> icon to locate the mapped descriptive flexfield columns ns3:Region and ns3:Comuna for the selected context value ns3:Chile (or select ns3:Zona and ns3:Parroquia for the selected context value ns3:Ecuador instead).

- In the To navigation tree, navigate to **Invoke\_SyncOrder\_InputVariable > InputParameters > ns2:InputParameters > ns2:P\_ORG\_CUST\_OBJ > ns2:ORGANIZATION\_OBJ > ns2:PARTY\_SITE\_OBJS > ns2:PARTY\_SITE\_OBJS\_ITEM > ns2:LOCATION\_OBJ > ns2:HZ\_LOCATIONS > ns3:ATTRIBUTE\_CATEGORY** and expand the <choice> icon to locate the mapped descriptive flexfield columns ns3:Region and ns3:Comuna for the selected context value ns3:Chile (or select ns3:Zona and ns3:Parroquia for the selected context value ns3:Ecuador instead).

To assign the parameters with descriptive flexfields in the **Assign** activity, drag the source node (ns3:Region) to connect to the first target node (ns3:Region) that you just specified. This creates a line that connects the source and target nodes. The copy rule is displayed in the From and To sections at the bottom of the Edit Assign dialog box.

Repeat the procedure to assign the second parameter by dragging the same source node (ns3:Comuna) to connect to the second target node (ns3:Comuna). The second copy rule is displayed in the From and To sections at the bottom of the Edit Assign dialog box.

Click **Apply** and **OK** to complete the **Assign** activity.

**Note:** Alternatively, since 'ns2:InputParameters' variables contained in the Source and Target are identical, you can simply drag the source node (ns2:InputParameters) to connect to the target node (ns2:InputParameters) and complete the **Assign** activity.

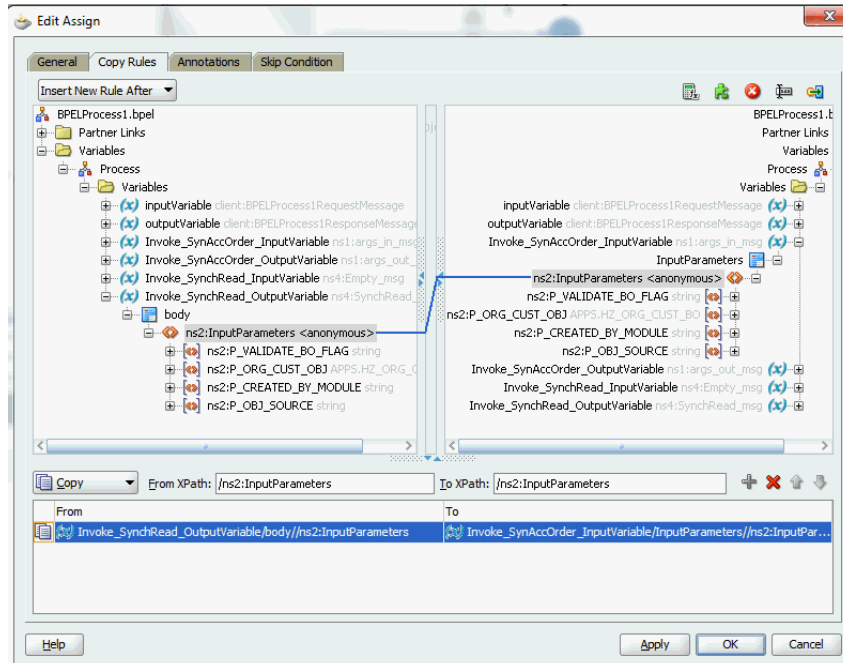

### Displaying Mapped Descriptive Flexfields at Runtime

After deploying the BPEL process contained in a SOA Composite application to the Oracle WebLogic managed server (such as 'soa-server1'), the descriptive flexfields we configured earlier are displayed in the soa-server1 server (<http://<servername>:<portnumber>/soa-infra>) allowing you to specify payload data and test the service invocation. Please note that you also test and manage the process from the Oracle Enterprise Manager Fusion Middleware Control Console.

**Note:** Please note that you can also test and manage the process from the Oracle Enterprise Manager Fusion Middleware Control Console. In this example, the mapped descriptive flexfields used as part of the input payload happen to be located or nested within multiple sub-levels down from the top. This means that we need to drill down to the mapped descriptive flexfields (Region and Comuna) by expanding the parameter nodes multiple times from the top level (Payload > P\_ORG\_CUST\_OBJ > ORGANIZATION\_OBJ > PARTY\_SITE\_OBJS > PARTY\_SITE\_OBJS\_ITEM > LOCATION\_OBJ > HZ\_LOCATIONS > ATTRIBUTE\_CATEGORY > HZ\_LOCATIONS\_1 to view descriptive flexfields). However, Oracle Enterprise Manager Fusion Middleware Control Console has certain limitations on displaying payload parameters if they are nested too deeply.



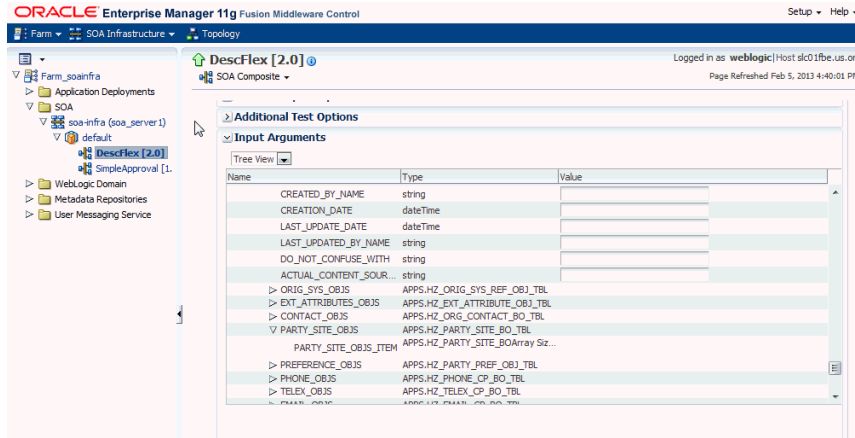

Therefore, in this case we access the mapped descriptive flexfields directly from the soa-infra in the soa-server1 server.

For information on how to test the service invocation from the Oracle Enterprise Manager Fusion Middleware Control Console, see Test the deployed SOA Composite application with BPEL process, page 9-49.

## Welcome to the Oracle SOA/BPM Platform on WebLogic

SOA Version: v11.1.1.7.0 - 11.1.1.7.0\_130123.2000.0834 built on Thu Jan 24 01:40:20 PST 2013  
 WebLogic Server 10.3.6.0 Tue Nov 15 08:52:36 PST 2011 1441050 (10.3.6.0)

The following composites are currently deployed:

1. default/DescFlex|2.0\*soa\_3847c4b0-4615-4cc8-b3b1-5b887a97c3be
  - o [Test bpelprocess1\\_client\\_ep](#)
2. default/SimpleApp|v11.0\*soa\_6181ce37-47b8-44fd-bef4-f965881f4e15
  - o [Test client](#)

### Useful links

- [SOA Composer](#)
- [BPM Worklist](#)
- [Business Process Workspace](#)
- [Business Process Composer](#)
- [B2B Console](#)
- [SOA Suite for healthcare integration](#)

Click the DescFlex project (the 'Test\_bpelprocess1\_client\_ep' link) to display the BPEL process information in HTML:

## bpelprocess1\_client\_ep endpoint

For a formal definition, please review the [Service Description](#).

Download the JavaScript Stub (BETA) for [BPPELProcess1\\_pt](#) and see its [documentation](#).

A list of all imported WSDL and Schema documents may be found [here](#)

### BPPELProcess1\_pt

Operation:   HTML Form  XML Source

WS-Security Sent In Header (optional)

payload

P_VALIDATE_BO_FLAG	<input type="text"/>	xsd:string	<input checked="" type="checkbox"/> Include In Message
<input checked="" type="checkbox"/> P_ORG_CUST_OBJ			<input checked="" type="checkbox"/> Include In Message
P_CREATED_BY_MODULE	<input type="text"/>	xsd:string	<input checked="" type="checkbox"/> Include In Message
P_OBJ_SOURCE	<input type="text"/>	xsd:string	<input checked="" type="checkbox"/> Include In Message

Note: XML source view contents will not be reflected in the HTML form view

Show Transport Info  
 Perform stress test  Enable

In the Payload section, expand the P\_ORG\_CUST\_OBJ node and navigate to ORGANIZATION\_OBJ > PARTY\_SITE\_OBJS > PARTY\_SITE\_OBJS\_ITEM > LOCATION\_OBJ > HZ\_LOCATIONS > ATTRIBUTE\_CATEGORY > HZ\_LOCATIONS\_1.

Two sets of descriptive flexfields configured earlier at the design time are now displayed at the runtime.

1. HZ\_LOCATIONS\_1\_0 (This is the default selection we configured in the Assign activity at the design time.)
  - Region
  - Comuna
2. HZ\_LOCATIONS\_1\_1
  - Zona
  - Parroquia

HZ\_LOCATIONS  Include In Message

---

ATTRIBUTE\_CATEGORY  xsd:string  Include In Message

HZ\_LOCATIONS\_1

---

HZ\_LOCATIONS\_1\_0

Region  xsd:string  Include In Message

Comuna  xsd:string  Include In Message

HZ\_LOCATIONS\_1\_1

Zona  xsd:string  Include In Message

Parroquia  xsd:string  Include In Message

PARTY\_SITE\_USE\_OBJS  Include In Message

---

PHONE\_OBJS  Include In Message

Enter appropriate data as payload and then click **Invoke** to invoke the service.

## Importing an Existing Flexfield Mapping

Instead of configuring a new mapping, you can simply import an existing mapping for your selected API. By using a previously configured mapping, you can quickly establish the flexfield mapping for your API or use it as a base with proper modification if needed.

To import an existing mapping, click **Import from File** in the Configure Flexfields region. The Open window appears where you can select a desired flexfield mapping.

### Selecting a desired flexfield mapping

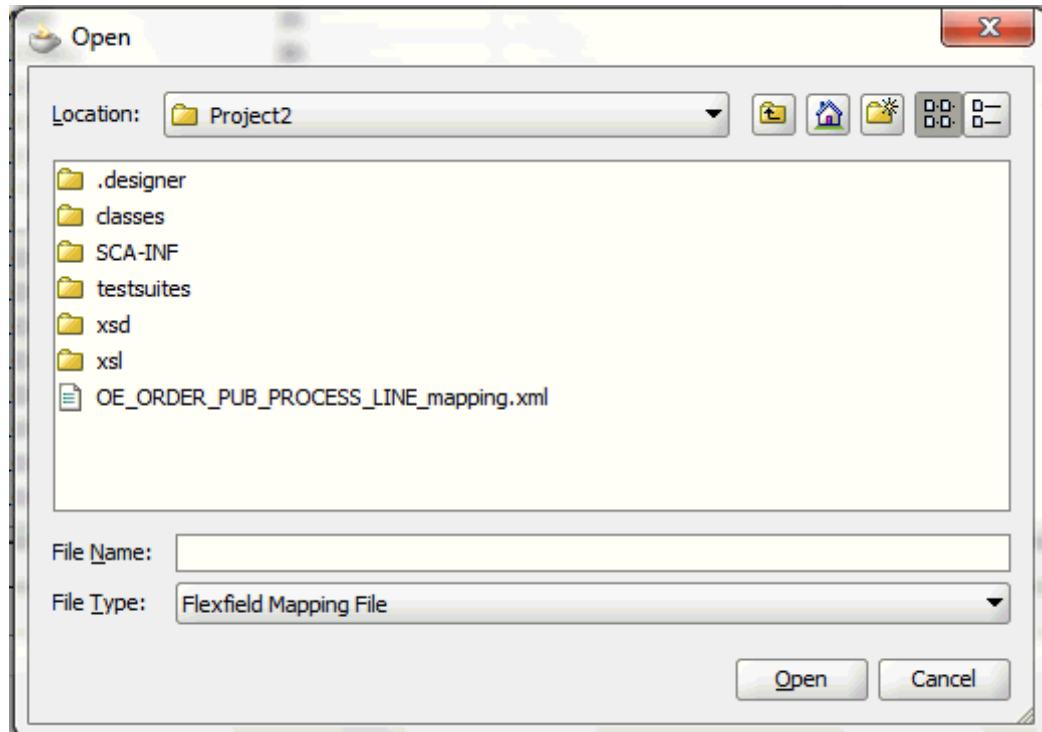

After selecting the desired mapping to be imported, click **Open**. The selected mapping file is automatically displayed in the Import Flexfield Data into the project field.

For example, select 'OE\_ORDER\_PUB\_PROCESS\_LINE\_mapping.xml' file and the imported mapping for the selected API is automatically displayed in the Parameters with Corresponding Flexfield Mappings region along with the selected mapping file name.

## Displaying Imported Flexfield Mapping File

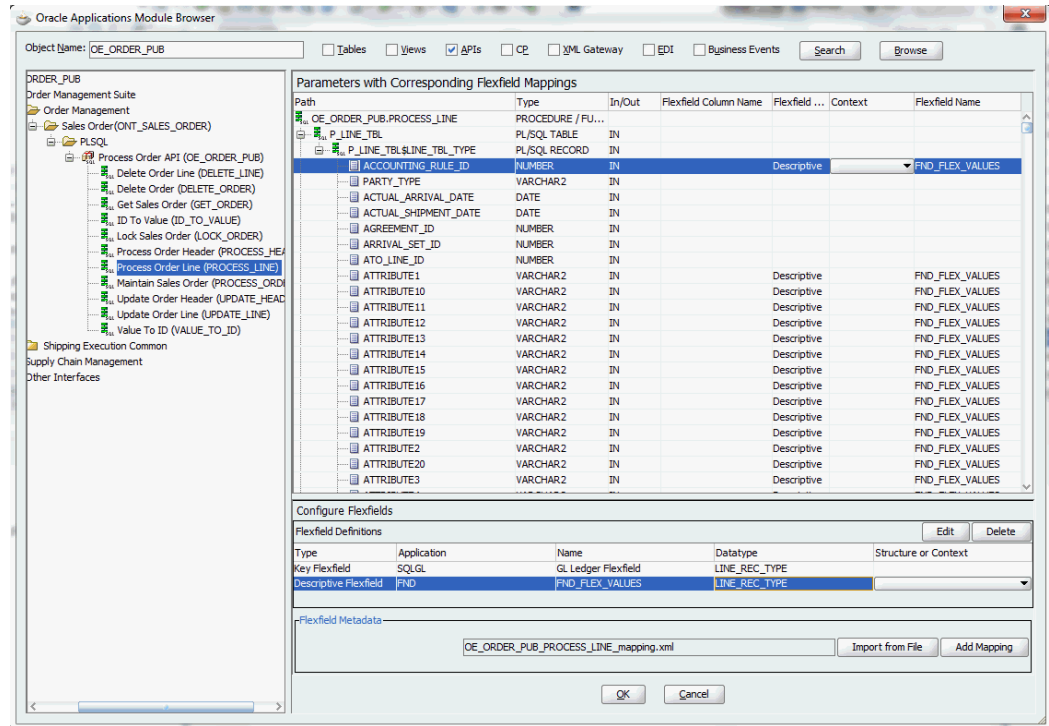

When a desired mapping is imported for the selected API, you will need to select the structure for a key flexfield and context values for a descriptive flexfields.

First, select the key or descriptive flexfield in the Flexfield Definitions section that requires modification, and then click **Edit**. The Flexfield Subflow - Welcome page is displayed. Click **Next** to select the desired flexfield context values if it's for a descriptive flexfield.

### Selecting the Context Values for Imported Mapping

The screenshot shows a window titled "Flexfield SubFlow - Step 6 of 6" with a close button in the top right corner. The main area is titled "Configure Flexfields" and contains the following text and controls:

- Instruction: "Select the Structure or Context and click next"
- Application: "Application Object Library"
- Flexfield Name: "FND\_FLEX\_VALUES"
- Context: A text box containing "%", followed by a "Query" button.
- A list of context values with checkboxes:
  - Endowment
  - FND\_TX\_CLASSES
  - FND\_TX\_GROUPS
  - France\_Nature
  - Global Data Elements
  - SSE\_Country
- Navigation buttons at the bottom: "Help", "< Back", "Next >", "Finish" (highlighted with a blue border), and "Cancel".

Click **Finish** to complete the descriptive flexfield mapping information. The updated descriptive flexfield context value (SSE\_Country) is now added both in the Parameters with Corresponding Flexfield Mappings region and Flexfield Definitions section.

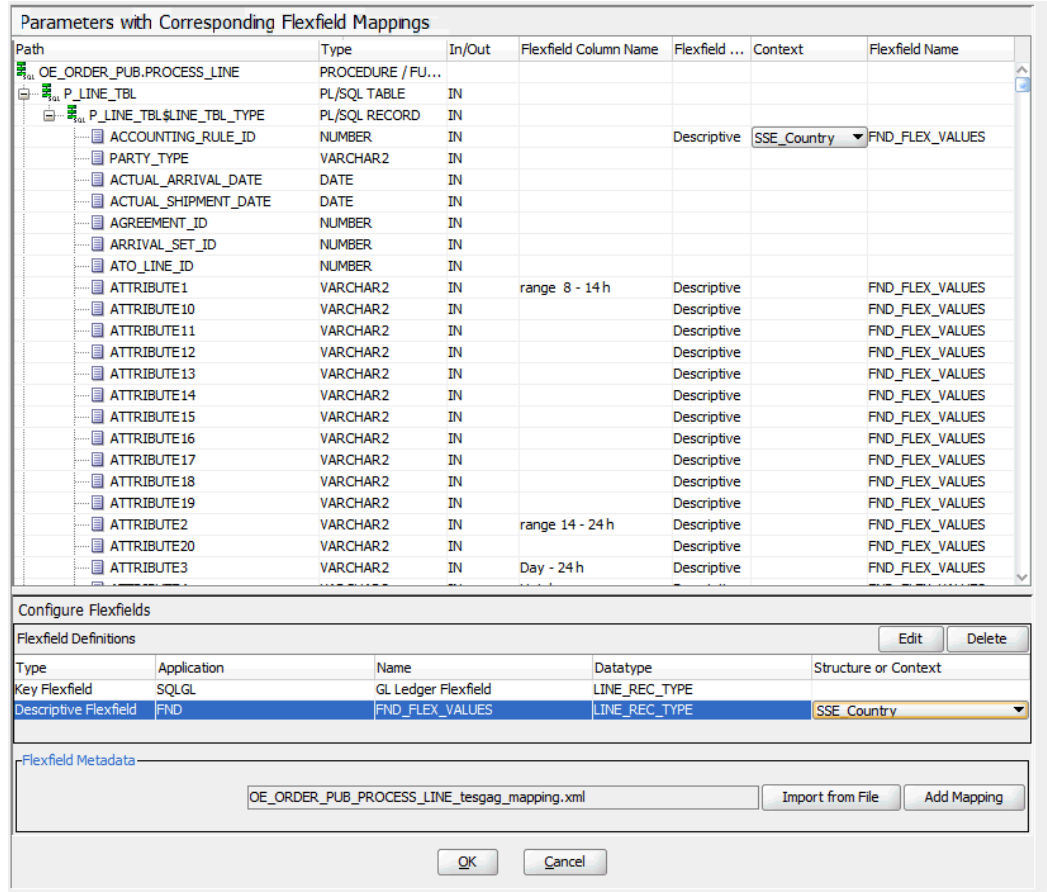

Use the same approach to update the key flexfield that requires structure information before clicking **OK**.

For more information on how to modify the selected mapping details, see *Modifying Your Flexfield Mapping*, page 4-77.

## Modifying Flexfield Definitions

Oracle Adapter for Oracle Applications allows you to modify flexfield definition for both key and descriptive flexfields as often as needed. However, modification is only limited to context values for a descriptive flexfield or flexfield structure for a key flexfield. If further update is needed in addition to modifying structure or context values, you should delete the flexfield mapping first and configure a new one.

### Modifying Flexfield Data

To modify flexfield data, select either the Key Flexfield or Descriptive Flexfield in the Flexfield Definitions section that you want to modify and then click **Edit**. Appropriate flexfield pages corresponding to your selected flexfield type appear where you can modify the flexfield details.

## Modifying Flexfield Mapping Data

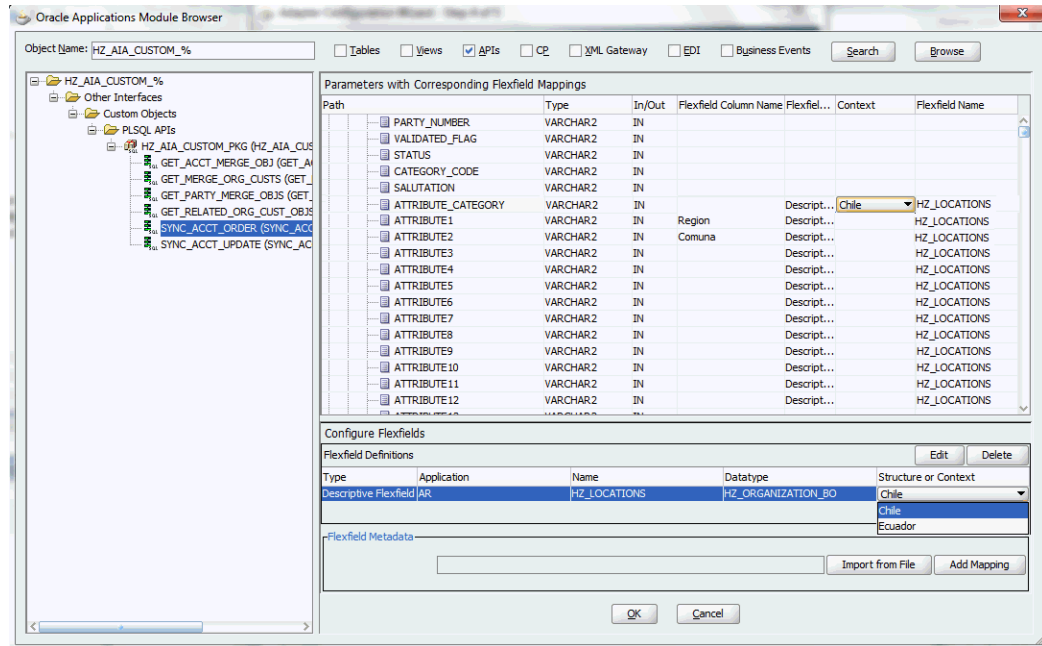

For example, modify the structure of the descriptive flexfield (HZ\_LOCATIONS). The Configure Flexfields window appears after you click **Next** in the Flexfield Subflow Welcome wizard.



### Flexfield Subflow - Configure Flexfields

Flexfield SubFlow - Step 6 of 6

#### Configure Flexfields

Select the Structure or Context(s) and click Finish.

Application: Receivables  
Flexfield Name: HZ\_LOCATIONS

Context : %

Chile  
 Ecuador  
 Global Data Elements

Click **Query** and select the 'Ecuador' check box only as the context value. Click **Finish** to complete the modification. The updated flexfield information should be reflected in the Flexfield Definitions section.

### Validating Modified Flexfield Mapping Data

Type	Application	Name	Datatype	Structure or Context
Descriptive Flexfield	AR	HZ_LOCATIONS	HZ_ORGANIZATION_BO	Ecuador

You can also validate the changes in the flexfield configuration xml file (`<projectname>_flex-config.xml`). See: *Reviewing Flexfield Configurations*, page 4-80.

For more information on how to configure or add each Flexfield Subflow window, see *Adding or Configuring a New Flexfield Mapping*, page 4-29.

### Deleting Flexfield Data

To delete flexfield data, select either the Key Flexfield or Descriptive Flexfield that you want to delete and then click **Delete**. This removes the selected flexfield data and the

associated structure or values from the database.

Alternatively, use [Control] and [Shift] keys to select multiple flexfields before the deletion.

## Reviewing Flexfield Configurations

After creating a partner link with flexfield information, from Oracle JDeveloper, expand the **SOA Content** folder and select the enhanced XSD file, for example `ProcessItem_KFF_flex.xsd`, to validate the flexfield information you configured or updated earlier.

The enhanced schema information is displayed with flexfield segment names based on the mapping chosen at the design time.

### Viewing an Enhanced XSD File

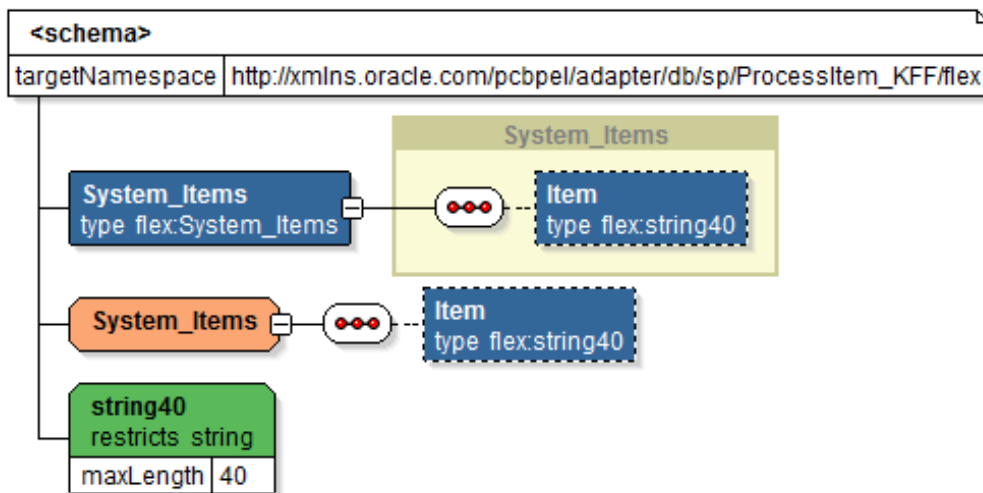

Additionally, two xml files are created along with the XSD file:

- **Mapping XML:** The mapping xml file (for example `INV_EBI_ITEM_PUB_PROCESS_ITEM_LIST_ProcessItem_KFF_mapping.xml`) would hold the mapping information captured in the mapping wizard panel. This information can be reused for the same API and can be imported from another Partner Link.

## Viewing Flexfield Mapping Details

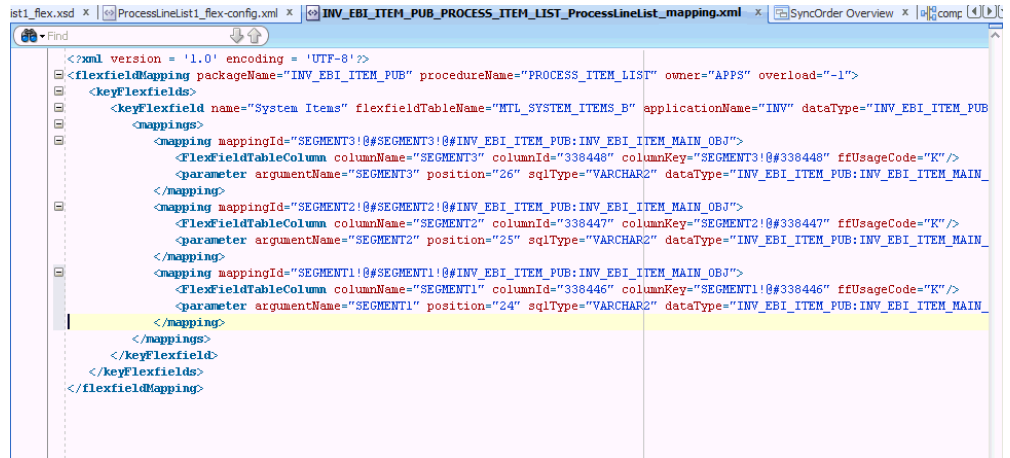

```
<?xml version = '1.0' encoding = 'UTF-8' ?>
<flexfieldMapping packageName="INV_EBI_ITEM_PUB" procedureName="PROCESS_ITEM_LIST" owner="APPS" overload="-1">
  <keyFlexfields>
    <keyFlexfield name="System Items" flexfieldTableName="MTL_SYSTEM_ITEMS_B" applicationName="INV" dataType="INV_EBI_ITEM_PUB">
      <mappings>
        <mapping mappingId="SEGMENT3!@#SEGMENT3!@#INV_EBI_ITEM_PUB:INV_EBI_ITEM_MAIN_OBJ">
          <FlexFieldTableColumn columnName="SEGMENT3" columnId="338448" columnKey="SEGMENT3!@#338448" ffUsageCode="K" />
          <parameter argumentName="SEGMENT3" position="26" sqlType="VARCHAR2" dataType="INV_EBI_ITEM_PUB:INV_EBI_ITEM_MAIN_" />
        </mapping>
        <mapping mappingId="SEGMENT2!@#SEGMENT2!@#INV_EBI_ITEM_PUB:INV_EBI_ITEM_MAIN_OBJ">
          <FlexFieldTableColumn columnName="SEGMENT2" columnId="338447" columnKey="SEGMENT2!@#338447" ffUsageCode="K" />
          <parameter argumentName="SEGMENT2" position="25" sqlType="VARCHAR2" dataType="INV_EBI_ITEM_PUB:INV_EBI_ITEM_MAIN_" />
        </mapping>
        <mapping mappingId="SEGMENT1!@#SEGMENT1!@#INV_EBI_ITEM_PUB:INV_EBI_ITEM_MAIN_OBJ">
          <FlexFieldTableColumn columnName="SEGMENT1" columnId="338446" columnKey="SEGMENT1!@#338446" ffUsageCode="K" />
          <parameter argumentName="SEGMENT1" position="24" sqlType="VARCHAR2" dataType="INV_EBI_ITEM_PUB:INV_EBI_ITEM_MAIN_" />
        </mapping>
      </mappings>
    </keyFlexfield>
  </keyFlexfields>
</flexfieldMapping>
```

How to import the flexfield\_mapping for a selected API, see Importing an Existing Flexfield Mapping, page 4-73.

- **Config XML:** The config xml (for example OE\_ORDER\_PUB\_PROCESS\_LINE\_GL\_Flexfield\_flex-config.xml) has the flexfield information including both key and descriptive flexfields if both configured. This is not reusable.

Please note that config xml is internal to the partner link, it should neither be edited nor reused.

## Viewing Flexfield Configuration Details

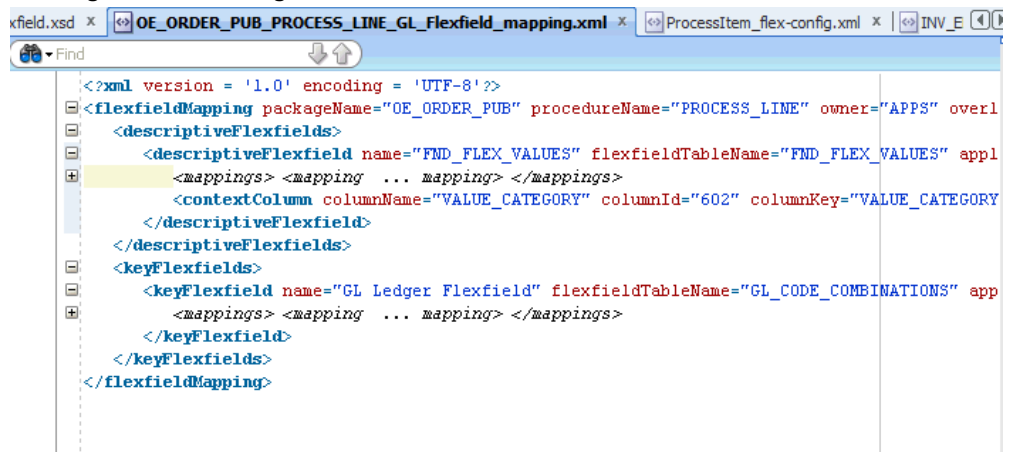

```
<?xml version = '1.0' encoding = 'UTF-8' ?>
<flexfieldMapping packageName="OE_ORDER_PUB" procedureName="PROCESS_LINE" owner="APPS" overl...>
  <descriptiveFlexfields>
    <descriptiveFlexfield name="FND_FLEX_VALUES" flexfieldTableName="FND_FLEX_VALUES" appl...>
      <mappings> <mapping ... mapping> </mappings>
      <contextColumn columnName="VALUE_CATEGORY" columnId="602" columnKey="VALUE_CATEGORY">
    </descriptiveFlexfield>
  </descriptiveFlexfields>
  <keyFlexfields>
    <keyFlexfield name="GL Ledger Flexfield" flexfieldTableName="GL_CODE_COMBINATIONS" app...>
      <mappings> <mapping ... mapping> </mappings>
    </keyFlexfield>
  </keyFlexfields>
</flexfieldMapping>
```

## Logging

Oracle Fusion Middleware Adapter for Oracle Applications implements the Oracle SOA

Suite's logging framework to write the diagnostic log files in text format. Therefore, whenever the Oracle E-Business Suite services are invoked using Oracle Adapter for Oracle Applications, the log messages are recorded which can be accessed by system administrator. This enriches the problem identification mechanism to track any issues during service invocations at run time for Oracle Adapter for Oracle Applications.

Oracle Adapter for Oracle Applications and technology adapters implement the `LogManager` interface of JCA Binding Component, which redirects the log files for both inbound and outbound interactions to the `soa-diagnostic.log` file in the Oracle Diagnostic Logging (ODL) format. These log files record all types of events including startup and shutdown information, errors and warning messages, access information on HTTP requests, and additional information. It provides a quick, inside-out view about the invocation process which greatly helps administrators identify and resolve potential issues efficiently. With proper log-level configuration in Oracle Enterprise Manager Fusion Middleware Control Console, you can view ODL level log files written to a single file at run time for Oracle Adapter for Oracle Applications as well as technology adapters.

To better understand how the logging mechanism work, the following topics are discussed in this chapter:

- Enabling Logging for Adapters, page 4-82
- Searching and Viewing Adapter Logs, page 4-88

For more information about SOA Suite, see *Oracle Fusion Middleware Administrator's Guide for Oracle SOA Suite*.

## Enabling Logging for Adapters

All logs of Oracle Adapter for Oracle Applications and technology adapters are redirected to the `soa-diagnostic.log` file in the Oracle Diagnostic Logging (ODL) format. To be able to view logs for Oracle Adapter for Oracle Applications, you need to set or enable an appropriate message type and its associated log level for the logger `oracle.soa.adapter` using the Oracle Enterprise Manager Fusion Middleware Control Console. This enables the log settings at the Oracle SOA Suite level.

**Note:** The logger configuration is under `$FMWHOME/user_projects/domains/soainfra/config/fmwconfig/servers/soa_server1/logging.xml` and the corresponding logger name for all Oracle JCA Adapters is called `oracle.soa.adapter`.

The following table lists the diagnostic message types and log levels:

**Note:** For each message type, possible values for message level are from 1 (highest severity) through 32 (lowest severity). Some components

support only some of the levels for each message type. Generally, you need to specify only the type; you do not need to specify the level.

The default message type for each logger is set to NOTIFICATION, level 1.

Message Type	Level	Description
INCIDENT_ERROR	1	<p>A serious problem that may be caused by a bug in the product and that should be reported to Oracle Support.</p> <p>Examples are errors from which you cannot recover or serious problems.</p>
ERROR	1	<p>A serious problem that requires immediate attention from the administrator and is not caused by a bug in the product.</p> <p>An example is if Oracle Fusion Middleware cannot process a log file, but you can correct the problem by fixing the permissions on the document.</p>
WARNING	1	<p>A potential problem that should be reviewed by the administrator.</p>
NOTIFICATION	1	<p>A major lifecycle event such as the activation or deactivation of a primary subcomponent or feature.</p>
NOTIFICATION	16	<p>A finer level of granularity for reporting normal events.</p>

Message Type	Level	Description
TRACE	1	Trace or debug information for events that are meaningful to administrators, such as public API entry or exit points.
TRACE	16	Detailed trace or debug information that can help Oracle Support diagnose problems with a particular subsystem.
TRACE	32	Very detailed trace or debug information that can help Oracle Support diagnose problems with a particular subsystem.

**To set the diagnostic message type and log level for Oracle Adapter for Oracle Applications in SOA Suite:**

Use the following procedures to set the message type and its associated log level:

1. Navigate to `http://<servername>:<portnumber>/em`.  
The Oracle Enterprise Manager Fusion Middleware Control Console home page is displayed.
2. Enter username and password to log on to the console.
3. Right-click `soa-infra` from the SOA Folder in the Navigator tree.
4. Select **Logs > Log Configuration** from the pop-up menu.

**Note:** You can also access the Log Configuration page by clicking the SOA Infrastructure Menu and selecting **Logs > Log Configuration** from the drop-down menu.

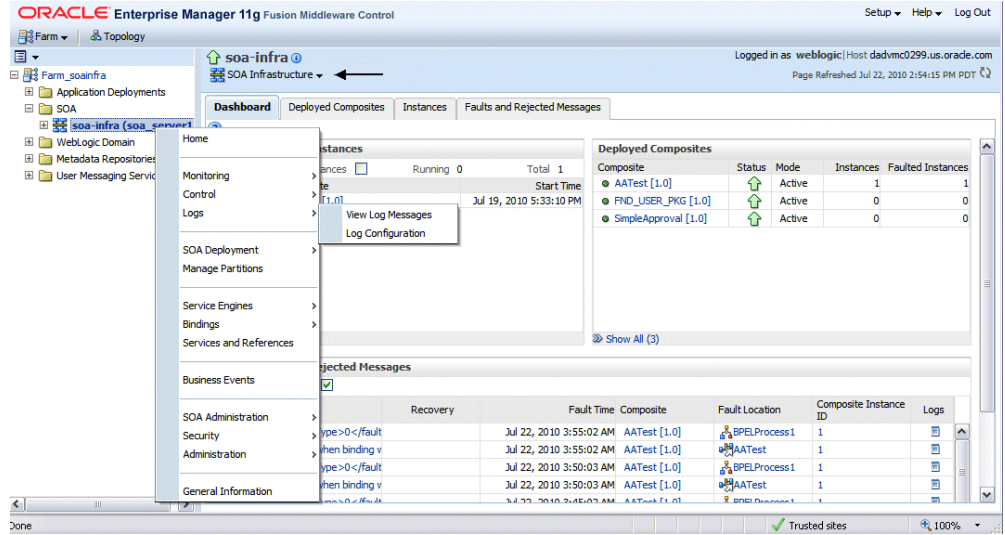

This opens the Log Configuration page where you can view a list of loggers (persistent or active run time) and configure the Oracle Diagnostic Logging (ODL) level for setting the amount and type of information to write to a log file and the log level state.

## Configuring Log Level for Adapters

The screenshot shows the Oracle Enterprise Manager 11g Fusion Middleware Control interface. The left pane shows the topology tree with 'soa-infra' selected. The main pane is titled 'Log Configuration' and contains a 'Log Levels' tab. Below the tab is a table of loggers. The 'View' dropdown is set to 'Runtime Loggers'. The table has the following data:

Logger Name	Oracle Diagnostic Logging Level (Java Level)	Log File	Persistent Log Level State
oracle.bpm	NOTIFICATION:1 (INFO) [Inheri]	odi-handler	
oracle.integration	NOTIFICATION:1 (INFO) [Inheri]	odi-handler	
oracle.sdp	NOTIFICATION:1 (INFO) [Inheri]	odi-handler	
oracle.sdpinternal	NOTIFICATION:1 (INFO) [Inheri]	odi-handler	
oracle.soa	NOTIFICATION:1 (INFO) [Inheri]	odi-handler	
oracle.soa.adapter	TRACE:32 (FINEST)	odi-handler	
oracle.soa.b2b	NOTIFICATION:1 (INFO) [Inheri]	odi-handler	
oracle.soa.bpel	NOTIFICATION:1 (INFO) [Inheri]	odi-handler	
oracle.soa.bpmn.engine	NOTIFICATION:1 (INFO) [Inheri]	odi-handler	
oracle.soa.bpmn.jp	NOTIFICATION:1 (INFO) [Inheri]	odi-handler	
oracle.soa.bpmn.system	NOTIFICATION:1 (INFO) [Inheri]	odi-handler	
oracle.soa.deployplan.DeployManager	NOTIFICATION:1 (INFO) [Inheri]	odi-handler	

5. Select the **Log Levels** tab.
6. Select one of the following values from the View drop-down list:
  - **Runtime Loggers (default):** Runtime loggers are automatically created during run time and become active when services are getting executed. For example, `oracle.soa.b2b` or `oracle.soa.bpel` are runtime loggers. Log levels for runtime loggers are not persistent across component restarts.
  - **Loggers with Persistent Log Level State:** Persistent loggers are loggers that are saved in a configuration file and become active when the component is started. The log levels for these loggers are persistent across component restarts.

**Note:** By default, the log level is set for Runtime Loggers. Runtime loggers do not persistent across when a component restarts. To ensure that log levels persist across component when it restarts, select **Loggers With Persistent Log Level State** from the View list.

7. Expand the `oracle.soa` node to locate `oracle.soa.adapter` runtime logger in the Logger Name list. Select the logging level from the Oracle Diagnostic Log Level drop-down list. For example, select 'TRACE:32 (FINEST)'.  
8. Click **Apply**.



### *Creating and Editing Log File in the Log Files Tab*

You can edit a specific log file by clicking the log handler link displayed in the Log File column. This opens the Log Files tab where you can configure the basic and advanced log configuration settings. These settings include handler's name, the log file in which the log messages are logged, the format of the log messages, the rotation policies used, and other parameters based on the log file configuration class.

For example, select the log handler from the table and click **Edit Configuration**. The Edit Log File dialog box is displayed.

- To change log file location, enter a new path in the Log Path field.
- To configure message levels, select the logging level from the Log Level drop-down list. For example, select 'TRACE:32 (FINEST)'.
- To configure log file rotation, in the Rotation Policy section, select either Size Based or Time Based log file with appropriate information.

For more information on how to configure log file, see the Managing Log Files and Diagnostic Data Chapter, *Oracle Fusion Middleware Administrator's Guide*.

For more information about SOA Suite, see *Oracle Fusion Middleware Administrator's Guide for Oracle SOA Suite*.

## **Automatic FND Logging for PL/SQL APIs and Concurrent Programs Using oracle.soa.adapter Runtime Logger**

Based on the log level set for `oracle.soa.adapter` runtime logger in Oracle SOA Suite, logging can be automatically controlled or enabled for PL/SQL APIs and Concurrent Programs while these interfaces are invoked during run-time execution. There is no need to enable the FND logging framework on the Oracle E-Business Suite side separately.

**Note:** This automatic FND logging would be available in Oracle E-Business Suite releases 12.1.3 and above only.

The following table lists the log level mapping between `oracle.soa.adapter` runtime logger and the corresponding Oracle E-Business Suite:

<b>Runtime Logger oracle.soa.adapter Log Level</b>	<b>Oracle E-Business Suite Log Level</b>
INCIDENT_ERROR	LEVEL_UNEXPECTED
ERROR	LEVEL_ERROR

Runtime Logger oracle.soa.adapter Log Level	Oracle E-Business Suite Log Level
WARNING	LEVEL_EXCEPTION
NOTIFICATION 1, 16, 32	LEVEL_EVENT
TRACE 1	LEVEL_PROCEDURE
TRACE 16, 32	LEVEL_STATEMENT

## Searching and Viewing Adapter Logs

Oracle Adapter for Oracle Applications and technology adapters implement the `LogManager` interface of JCA Binding Component, which redirects the log files written to a single file at run time in the Oracle Diagnostic Logging (ODL) format.

For both outbound and inbound interactions, the log files are redirected to the single file `soa-diagnostic.log`.

The log files for Oracle SOA Suite that is deployed to the `server-soa` managed server are located in

```
MW_HOME/user_projects/domains/<domain_name>/servers/server-soa/logs/soa-diagnostic.log.
```

To search and view Oracle Adapter for Oracle Applications log files, you can use Oracle Enterprise Manager Fusion Middleware Control Console, the `WLST displayLogs` command-line tool, or you can download log files to your local client and view them using another tool (for example a text editor, or another file viewing utility). For information on how to use `WLST` command-line tool to search and view log files, see the Managing Log Files and Diagnostic Data Chapter, *Oracle Fusion Middleware Administrator's Guide*.

### Steps to Search and View Adapter Logs Using Oracle Enterprise Manager Fusion Middleware Control Console

Use the following steps to search Adapter Logs through the Oracle Enterprise Manager Fusion Middleware Control Console:

1. Navigate to `http://<servername>:<portnumber>/em`.  
The Oracle Enterprise Manager Fusion Middleware Control Console home page is displayed.
2. Enter username and password to log on to the console.
3. There are two ways to access the Log Messages page from the Navigator tree in the

left pane:

- From the SOA folder, right-click soa-infra.

### Navigating from SOA Folder

The screenshot displays the Oracle Enterprise Manager 11g Fusion Middleware Control interface. The left pane shows a tree view with the following structure:

- Farm\_soainfra
  - Application Deployments
  - SOA
    - soa-in (selected)
    - WebLogic Domain
    - Metadata Repository
    - User Messaging Service

The main pane shows the 'soa-in' folder selected, displaying a 'Deployments' table and a 'Fusion Middleware' summary. The 'Deployments' table is as follows:

Application Deployments	Status	Target
Internal Applications		
Source Adapters		
PMComposer	Up	soa_server 1
Composer	Up	soa_server 1
defaultToDoTaskFlow	Up	soa_server 1
OracleBPMComposerRolesApp	Up	soa_server 1
OracleBPMProcessRolesApp	Up	soa_server 1
OracleBPMWorkspace	Up	soa_server 1
OracleApprovalTaskFlow	Up	soa_server 1
prklistapp	Up	soa_server 1
soa-infra	Up	soa_server 1
default	Up	soa_server 1

The 'Fusion Middleware' summary shows a 20% health indicator and a table of components:

Name	Status	Host
WebLogic Domain		
soainfra		
AdminServer	Up	dadvmc0299.us...
bam_server 1	Down	dadvmc0299.us...
soa_server 1	Up	dadvmc0299.us...
Metadata Repositories		
mids-owsm		dadvmc0299.us...
mids-soa		dadvmc0299.us...
User Messaging Service		
usermessagingdriver-email (soa_s...	Up	dadvmc0299.us...
usermessagingserver (soa_server 1)	Up	dadvmc0299.us...

- From the WebLogic Domain folder, right-click soainfra.

## Navigating from WebLogic Domain Folder

The screenshot shows the Oracle Enterprise Manager 11g Fusion Middleware Control interface. The left-hand navigation tree is expanded to the 'soainfra' folder under 'WebLogic Domain'. A context menu is open over the 'soainfra' folder, with 'Logs' selected and 'View Log Messages' highlighted. The main console area displays the 'soainfra' domain summary, including a pie chart showing 87% up and 13% down, and a table of server status.

Host	Cluster	Listen Port	Active Sessions	Request Processing Time (ms)	Bytes Accessed (per minute)
dadvm...		7001	1	86	0.00
dadvm...		Unaval...	Unaval...	Unaval...	Unaval...
dadvm...		8001	0	0	2.15

Select **Logs** > **View Log Messages** from the pop-up menu. The Log Messages page is displayed with the Search section and a table that shows a summary of the messages with default search criteria.

## Log Messages Page: Search

The screenshot shows the Oracle Enterprise Manager 11g Log Messages Search page. The search criteria are: Date Range: Most Recent, 8 Hours; Message Types: Incident Error, Trace; Message: contains Oracle Applications adapter. The search results table is empty, showing '(No messages matched the search criteria.)'.

#### 4. Enter the following search criteria for searching the log messages for Oracle Adapter for Oracle Applications:

- **Date Range:** Select your value from the drop-down list and enter an appropriate number. For example, 'Most Recent' 6 hours.

If 'Time Interval' is selected from the drop-down list, select the calendar icon for Start Date and then select the date and time. Similarly, select the calendar icon for End Date and then select the date and time.

- **Message Types:** Select one or more of the message types. For example, select the **Trace** check box if it is the message type configured earlier for Oracle Adapter for Oracle Applications.
- **Message:** Select 'Contains' from the list of values and then enter 'Oracle Applications Adapter' in the text box.
- Specify more search criteria if needed in the Search section.

You can optionally add more search criteria by clicking **Add Fields**. This action allows you to add more criteria, such as Host, which lets you narrow the search to particular hosts. Then click **Add**.

#### 5. Execute the search by clicking **Search**. All messages that match your search criteria will be retrieved and displayed in the table. These messages can be displayed as messages, or can be grouped by message type or message ID depending on the selected value in the Show field.

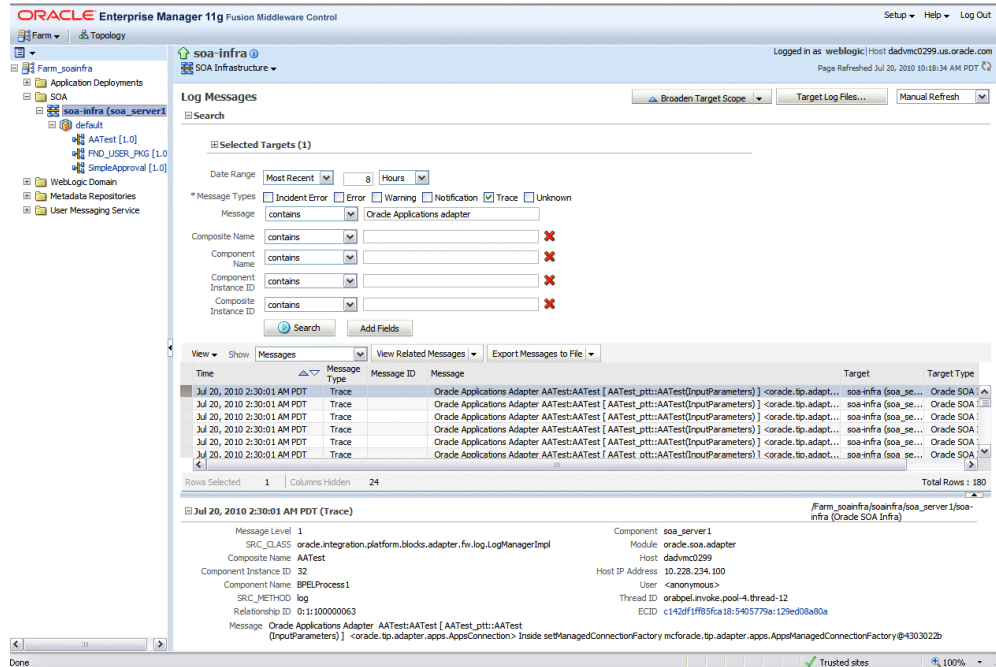

6. Click one of the log messages from the table. The selected message details, such as message level, component, ECID (Execution Context ID), Relationship ID, actual message, are displayed below the table of messages.

Clicking the ECID link retrieves related messages with the same ECID in the Related Messages by ECID page. For more information on related messages, see Correlating Messages Across Log Files and Components, page 4-94.

7. Select an appropriate output option from the **Export Messages to File** drop-down list if you want to export log messages as a Oracle Diagnostic Log Text file (.txt) XML file (.xml), or Comma-Separated List (.csv) file.
8. Click **Target Log Files** to open the Log Files page where you can view a list of log files related to the managed server (`server-soa`).

## Log Files Page

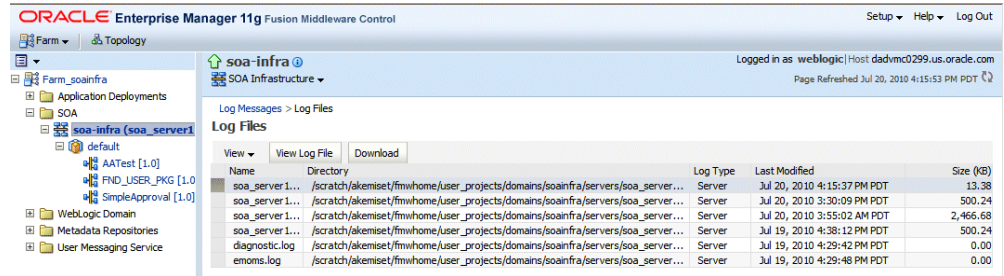

1. Select a file and click **View Log File**. The View Log File page is displayed for the selected log file where you can view a list of messages contained in this log.

## View Log File Page

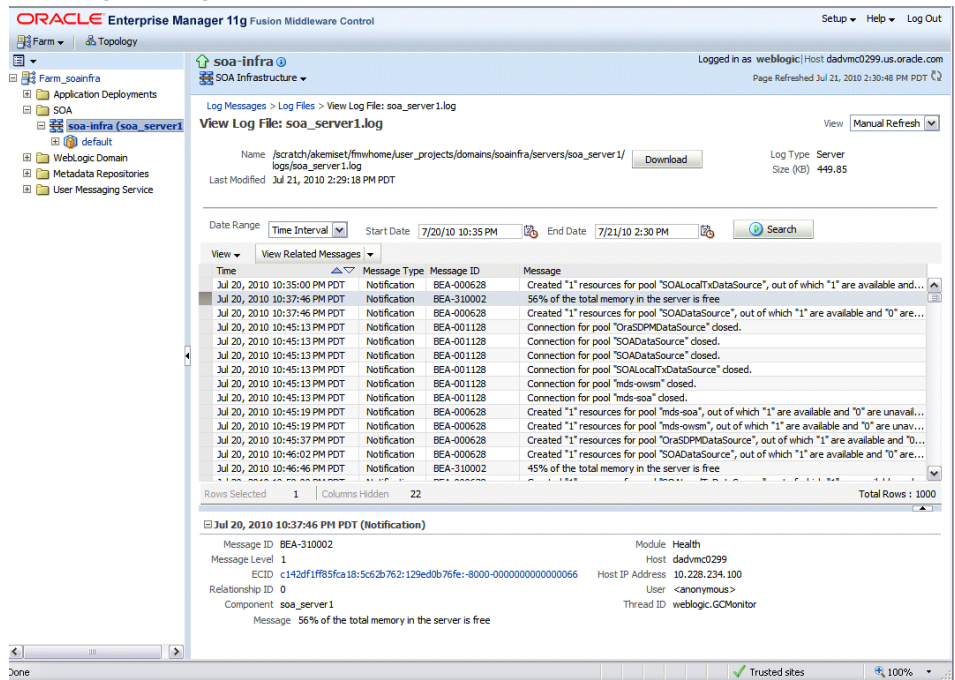

2. To view the details of a message, select the message. The message details, such as message level, component, ECID, Relationship ID, actual message, are displayed below the table of messages.
3. To view messages that are related by time or ECID, click **View Related Messages** and select 'by Time' or by 'ECID (Execution Context ID)'.  
Alternatively, clicking the ECID link directly from the message details also retrieves related messages with the same ECID in the Related Messages by ECID page.

## Correlating Messages Across Log Files and Components

Oracle Fusion Middleware components provide **message correlation** information for diagnostic messages. Message correlation information helps those viewing diagnostic messages to determine relationships between messages across components. Each diagnostic message contains an Execution Context ID (ECID) and a Relationship ID.

An ECID is a globally unique identifier associated with the execution of a particular request. An ECID is generated when the request is first processed. A Relationship ID distinguishes the work done in one thread on one process from the work done by any other threads on this and other processes on behalf of the same request.

While viewing log messages in the Oracle Enterprise Manager Fusion Middleware Control Console, you can view correlated messages by selecting a log message first, and then selecting one of the following values from the **View Related Messages** drop-down list:

**Note:** The **View Related Messages** selection is available only when 'Messages' is chosen in the Show field when displaying all matching messages based on search criteria. If 'Group by Message Type' or 'Group by Message ID' is selected in the Show field, then all matching messages are displayed by groups based on message type or message ID. In this situation, the **View Related Messages** field is not available.

- **by Time:** This displays the Related Messages by Time page where all messages with the same timestamp as the selected message are displayed in this page.



## Related Messages by Time Page

ORACLE Enterprise Manager 11g Fusion Middleware Control

Setup Help Log Out

Farm soa-infra Topology

soa-infra SOA Infrastructure

Logged in as weblogic@Host dadvmc0299.us.oracle.com  
Page Refreshed Jul 22, 2010 2:41:19 PM PDT

Log Messages > Related Messages by Time: Jul 22, 2010 3:55:02 AM PDT

Related Messages by Time: Jul 22, 2010 3:55:02 AM PDT

Selected Targets (1)

View View Related Messages Export Messages to File Scope: 30 seconds

Time	Message Type	Message ID	Message
Jul 22, 2010 3:55:02 AM PDT	Trace		Oracle Applications Adapter AATest:AA [ AATest_pitt::AA [ est(InputParameters) ] <oracle.tp.adapt
Jul 22, 2010 3:55:02 AM PDT	Trace		Oracle Applications Adapter AATest:AA [ AATest_pitt::AA [ est(InputParameters) ] <oracle.tp.adapt
Jul 22, 2010 3:55:02 AM PDT	Trace		Oracle Applications Adapter AATest:AA [ AATest_pitt::AA [ est(InputParameters) ] <oracle.tp.adapt
Jul 22, 2010 3:55:02 AM PDT	Trace		Oracle Applications Adapter AATest:AA [ AATest_pitt::AA [ est(InputParameters) ] <oracle.tp.adapt
Jul 22, 2010 3:55:02 AM PDT	Error		JCABnding=> AATest:AA [ AATest_pitt::AA [ est(InputParameters) ] Could not invoke operation AA
Jul 22, 2010 3:55:02 AM PDT	Trace		Oracle Applications Adapter AATest:AA [ AATest_pitt::AA [ est(InputParameters) ] <oracle.tp.adapt
Jul 22, 2010 3:55:02 AM PDT	Trace		Oracle Applications Adapter AATest:AA [ AATest_pitt::AA [ est(InputParameters) ] <oracle.tp.adapt

Jul 22, 2010 3:55:02 AM PDT (Trace) /Farm\_soainfra/soainfra/soa\_server1/soa-infra (Oracle SOA Infra)

Message Level 1 Component soa\_server1

SRC\_CLASS oracle.integration.platform.blocks.adapter.fw.log.LogManagerImpl Module oracle-soa.adapter

Composite Name AATest Host dadvmc0299

Component Instance ID 145 Host IP Address 10.228.234.100

Component Name BPPELProcess1 User <anonymous>

SRC\_METHOD log Thread ID oraBPPEL.invoke.pool-4.thread-5

Relationship ID 0:1:100000289 ECID c142df1f85fca18:5405779a:129ed08a80a

Message Oracle Applications Adapter AATest:AA [ AATest\_pitt::AA [ est(InputParameters) ] <oracle.tp.adapter.apps.AppsConnection> issuing close on m ix

- **by ECID (Execution Context ID):** This displays the Related Messages by ECID page where all messages with the same ECID as the selected message are displayed in this page.

## Related Messages by ECID Page

The screenshot shows the Oracle Enterprise Manager 11g Fusion Middleware Control interface. The main window displays the 'Related Messages by ECID' page for a specific ECID: c142df1ff85fca18:5405779a:129ed08a80a. The page shows a list of messages with columns for Time, Type, Message ID, and Message. The messages are sorted by time, and an error message is highlighted. The error message is: 'Oracle Applications Adapter AATest:AAATest [ AATest\_pttt:AAATest(InputParameters) ] Could not invoke operation 'AA'. The detailed view of the selected message shows the following information:

Property	Value
Message Level	1
SRC_CLASS	oracle.integration.platform.blocks.adapter.fw.log.LogManagerImpl
Composite Name	AAATest
Component Instance ID	50
Component Name	BPPELProcess1
SRC_METHOD	log
Relationship ID	0:1:100000099
Component	soa_server1
Module	oracle.soa.adapter
Host	dadvmc0299
Host IP Address	10.228.234.100
User	<anonymous>
Thread ID	orappel.invoke.pool-4.thread-10
ECID	c142df1ff85fca18:5405779a:129ed08a80a

By searching for related messages using the message correlation information, multiple messages can be examined and the component that first generates a problem can be identified. Message correlation data can help establish a clear path for a diagnostic message across components, within which errors and related behavior can be understood.

## Enhanced Error and Exception Handling

In order to identify the root cause of an issue or error which might occur during invocation of an Oracle E-Business Suite interface, Adapter for Oracle Applications now provides user-friendly, descriptive exceptions and error messages. Especially, these would be available during invocation of any PL/SQL APIs or Concurrent Programs.

Apart from handling errors during adapter preprocessing and the run-time execution by Database Adapter and AQ Adapter, it also provides a way to retrieve the functional errors raised by PL/SQL APIs at run time, without the need for an extra call to retrieve them. These messages would guide you to pinpoint the cause of failures at run time.

Additionally, based on the common logging framework used by other JCA Adapters, all errors and exceptions pertaining to Adapter for Oracle Applications and debug information will be logged. This allows administrators or developers to better understand what happened during the execution and take necessary actions to solve the issue.

## Handling Functional Errors

During the invocation of an integrated interface supported by Adapter for Oracle Applications, in case of issues or errors occurred (such as the entered order number does not exist while invoking `OE_ORDER_PUB.CHANGE_ORDER` API), an exception (`ORA-20100: Order number does not exist`) would be thrown and such exception consists of functional errors. This type of exception is used extensively to report functional problems while executing the API.

For most PL/SQL APIs, functional errors can be thrown as `SQLException` caught by Adapter run-time engine along with code and message or as part of API output parameters. However, certain PL/SQL APIs do not throw functional errors during execution, but they keep on accumulating them in the memory stack. The responsibility of fetching the errors is deferred to the caller of the APIs.

For example, HRMS APIs put functional errors in `FND_MESSAGE` stack using `FND_MSG_PUB.put` package. Upon completion of the API call, the caller must explicitly fetch the errors from this stack using `FND_MSG_PUB.GET()` methods.

**Note:** Error messages can only be retrieved from the stack `FND_MSG_PUB` in this release.

For such APIs that require explicit handling, a new JCA property called `APIErrorHandler` is introduced to fetch functional errors from the `FND_MESSAGE` memory stack. This property serves as an error-fetching indicator so that the caller can retrieve the errors without the need for an explicit call to retrieve them. During run-time execution, Adapter for Oracle Applications checks for the presence of the JCA property `APIErrorHandler`. If it is present, the error handler would be invoked right after the execution of the PL/SQL API.

Please note that the following functional error handling parameter needs to be added to the WSDL file (`XX_apps.jca`) for fetching the functional errors for such APIs:

```
<property name="APIErrorHandler"
value="FND_MSG_PUB.GET_DETAIL"/>
```

## Secured Connection Between Oracle E-Business Suite and Oracle Fusion Middleware SOA Suite Using J2EE Data Source Implementation

By implementing the J2EE Data Source for secured connection between Oracle E-Business Suite and Oracle SOA Suite, two distinct advantages can be leveraged. Firstly, to get the secured connection to the Oracle E-Business Suite's application database, you do not require Apps/Apps-equivalent schema's username and password, just FND username and password (concept of Oracle Applications username and password) is sufficient. Secondly, since the password is not stored in the middleware, not only this eliminates the security risk, but also does away the need to keep the password in-sync between Oracle E-Business Suite and SOA Suite.

Oracle Adapter for Oracle Applications uses a new mechanism to authenticate users at run time and get the connection to Oracle E-Business Suite databases through the use of J2EE data sources. This approach is native to Oracle E-Business Suite in defining the connection pool to access the application database.

With this new mechanism, account details information including application login user name and password that was required as part of the configuration for database connection is now added together with the dbc file location as input parameters during the J2EE data source creation.

To accomplish this process, the following steps are used to define J2EE data source connection to the Oracle E-Business Suite database:

1. Register your Service-Oriented Architecture (SOA) suite middle tier node on the Oracle E-Business Suite environment and generate the dbc file used by the data source implementation to instantiate the connections.
2. Copy the dbc file to the middle tier server where your SOA suite server runs, and place it on a location in the file system to which the SOA suite owner has access.
3. Create a connection pool where you need to enter the application login user name, password, and dbc file location as the connection factory properties.
4. Create an application data source. This is the step that you associate the application data source with the Java Naming and Directory Interface (JNDI) name for the application database connection for Oracle Adapter for Oracle Applications.

To enable the native Oracle E-Business Suite connectivity using J2EE data sources feature,

**Note:** To have this feature available, the minimum requirement for Oracle E-Business Suite Release 11*i* is 11*i*.ATG\_Pf.H.Delta.6 (RUP6) and for Oracle E-Business Suite Release 12 is 12.0.4 release.

Additionally, you must apply necessary patches to enable the connectivity between Oracle E-Business Suite and an external application server. See "Oracle Fusion Middleware Adapter for Oracle Applications, Release 11g" My Oracle Support Knowledge Document 787637.1 for details.

## Understanding the Oracle Applications Module Browser

The Oracle Applications Module Browser is a key component of Adapter for Oracle Applications. In addition to the interfaces that are made available through Oracle Integration Repository, Adapter for Oracle Applications enables you to use business events and event groups, custom PL/SQL APIs, and custom XML Gateway maps, all of which you can explore using the Oracle Applications Module Browser.

Use the Module Browser to select the interface needed to define a partner link. It can be used in the following ways to locate desired interfaces:

- Locating interfaces by Search
- Locating interfaces by Browse

### Searching Interfaces

Enter desired interface name or partial values containing wildcard characters in the Object Name field and click **Search** to locate the desired interface in the Module Browser.

#### ***Searching Interfaces Through Oracle Applications Module Browser***

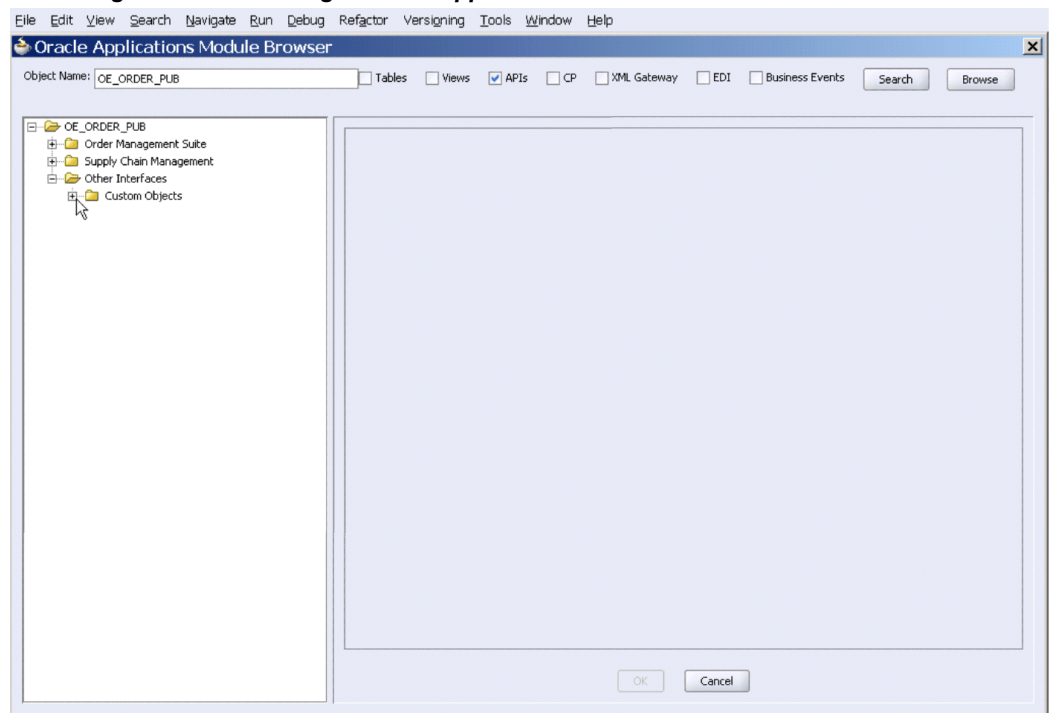

### Browsing Interfaces Through Tree Structure

The Module Browser combines interface data from Oracle Integration Repository along with additional interfaces supported by Adapter for Oracle Applications.

## Browsing Interfaces by Expanding Tree Structure

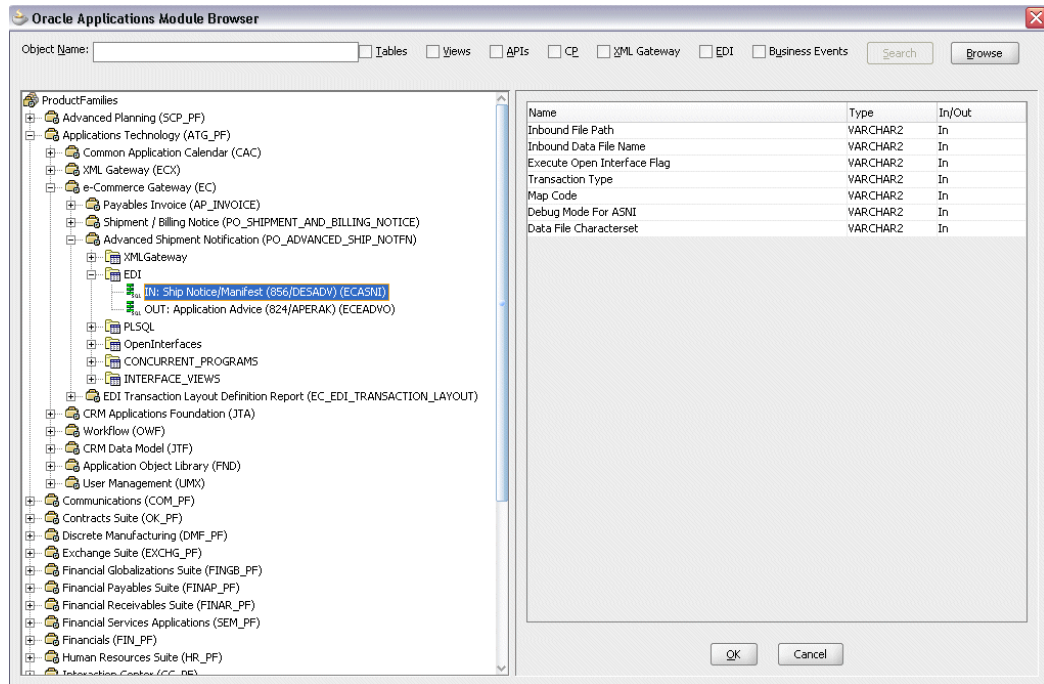

The supported interfaces are organized in a tree hierarchy as follows:

```

ProductFamilies
|- [product_family]
|   |- [product]
|       |- [business_entity]
|           |-XML Gateway ([n])
|           |-EDI ([n])
|           |-PLSQL ([n])
|               |- [package_name]
|                   |-OpenInterfaces ([n])
|                       |- [OpenInterface_name]
|                           |-Tables ([n])
|                           |-Views ([n])
|                           |-ConcurrentPrograms ([n])
|-Other Interfaces
    |-Business Events
        |-Inbound
        |-Outbound
            |-Groups
                |- [business event name]
    |-Custom Objects
        |-PLSQL APIs
            |- [package_name]
        |-XMLGateway Maps
            |-Inbound
            |-Outbound
        |-Concurrent Programs
            |- [concurrent program name]
    
```

- The items under Other Interfaces, as well as certain PL/SQL APIs and concurrent programs under the *[product family]* hierarchy, are available through Adapter for Oracle Applications, but not through Oracle Integration Repository.
- The number of interfaces indicated by [n] only appears in case of an Oracle E-Business Suite 11.5.10 instance is used. It will not be displayed if you are connecting to an Oracle E-Business Suite release 11.5.9 or release 12 instance.

### Browsing Interfaces by Product Family

The Oracle Integration Repository interface data populates the *[product\_family]* sections, grouped according to the products and business entities to which they belong.

#### Browsing Interfaces by Product Family

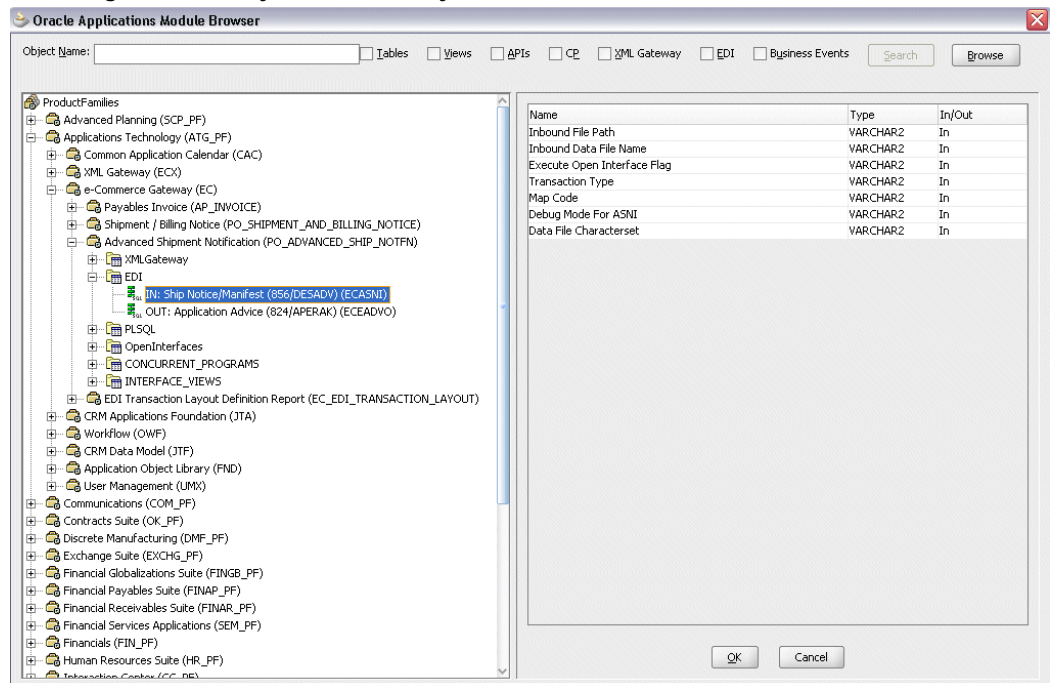

### Browsing Business Events and Custom Interfaces Under 'Other Interfaces'

Business events and custom interfaces are displayed under the Other Interfaces note.



## Browsing Other Interfaces

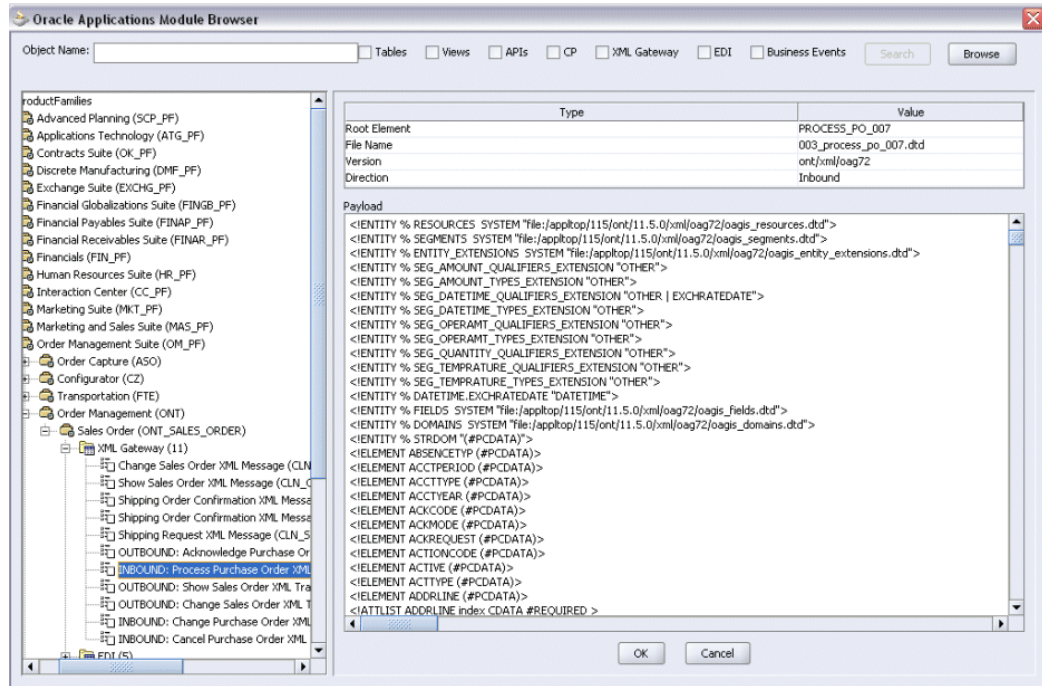

- **Business Events and Business Event Groups**

Business events and business event groups appear under the Other Interfaces node from the Oracle Applications Module Browser.

A business event group is a type of event containing a set of individual business events. Clicking the **Other Interfaces > Business Events > Outbound > Groups** node displays the business event groups.

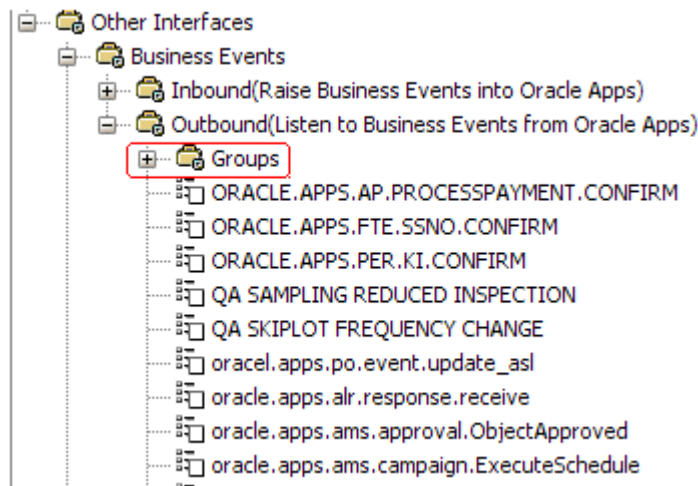



- **Custom Interfaces**

Custom interfaces are displayed under the **Other Interfaces > Custom Objects** node from the Oracle Applications Module Browser.

### Browsing Custom Interfaces

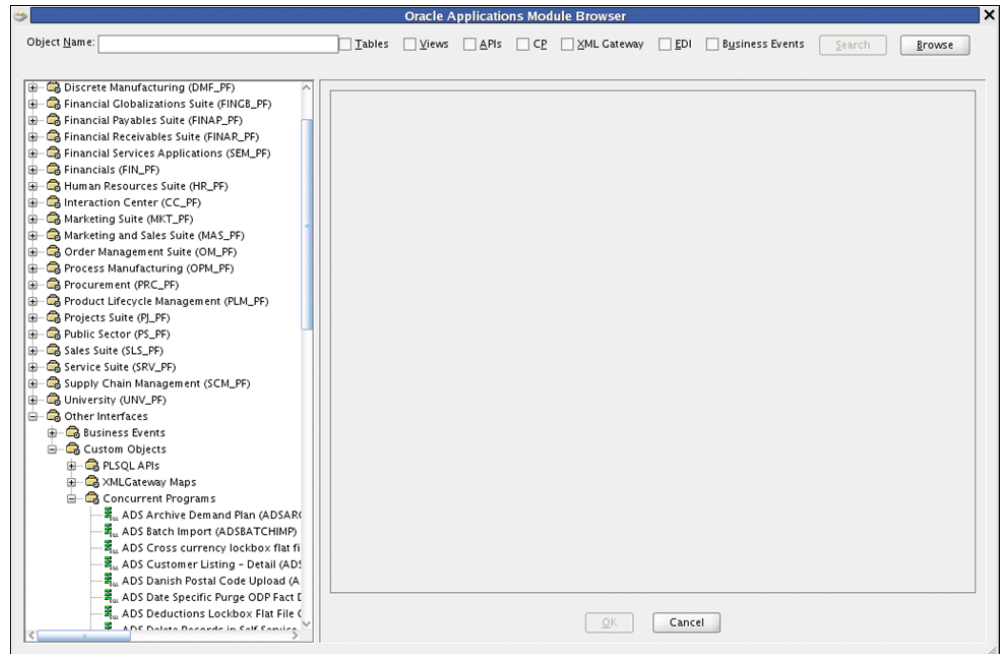

The supported custom interfaces are listed as follows:

- Custom PL/SQL APIs

Custom PL/SQL APIs appear in two places:

- Procedures within a package that's already exposed via Oracle Integration Repository appear under the package name within a product family hierarchy.
- Procedures within a completely new package appear under the package name, under **Other Interfaces > Custom Objects**.

- Custom XML Gateway Maps

Custom XML Gateway maps are categorized as either Inbound or Outbound. Select either one of the nodes to display custom XML Gateway maps.

- Customized Concurrent Programs

Clicking the Concurrent Programs node under the Custom Objects node displays all the custom concurrent programs.



---

## Using XML Gateway

This chapter covers the following topics:

- Overview of XML Gateway
- Design-Time Tasks for XML Gateway Inbound Messaging
- Creating a New SOA Composite Application with BPEL Process
- Creating a Partner Link
- Adding a Partner Link for the File Adapter
- Configuring the Invoke Activities
- Configuring the Assign Activity
- Run-Time Tasks for XML Gateway Inbound Messaging
- Deploying the SOA Composite Application with BPEL Process
- Testing the SOA Composite with BPEL Process
- Verifying Records in Oracle E-Business Suite
- Design-Time Task for XML Gateway Outbound Messaging
- Creating a SOA Composite Application with BPEL Process
- Adding a Partner Link
- Adding a Receive Activity
- Adding a Partner Link for File Adapter
- Adding an Invoke Activity
- Adding an Assign Activity
- Run-Time Task for XML Gateway Outbound Messaging
- Deploying the SOA Composite Application with BPEL Process
- Testing the SOA Composite Application with BPEL Process
- Troubleshooting

## Overview of XML Gateway

Oracle Adapter for Oracle Applications provides a bridge between Oracle Applications and third party applications. Inbound and outbound XML data is exchanged between Oracle Applications and third party applications through the XML Gateway.

Oracle XML Gateway provides a common, standards-based approach for XML integration between Oracle Applications and third party applications, both inside and outside your enterprise. XML is key to an integration solution, as it standardizes the way in which data is searched, exchanged, and presented thereby enabling interoperability throughout the supply chain.

Oracle XML Gateway is an XML messaging based integration infrastructure essentially for business partner integration which includes a set of services that allows easy integration between Oracle Applications and third party applications. Oracle Applications utilize the Oracle Workflow Business Event System to support event-based XML message creation and consumption.

Oracle Adapter for Oracle Applications can be configured to use XML Gateway to interact with third party applications. The tight integration provided by open interface tables is not suitable for those scenarios where trading partners change frequently. XML Gateway is an ideal solution when you need to interact with third party applications that use open standards. Moreover, it is also suitable for scenarios where trading partners change frequently.

## Standards-Based Messaging

As a provider of broad based business application solutions to support all industries, Oracle XML Gateway supports all Document Type Definition (DTD) based XML standards. The majority of the Oracle prebuilt messages delivered with Oracle Applications are premapped using the Open Application Group (OAG) standard. Any Oracle prebuilt message map may be remapped to your standard of choice using the XML Gateway Message Designer.

## Integration Architecture

XML Gateway provides an application integration infrastructure that is flexible enough to accommodate the integration requirements of any application that needs to integrate with Oracle Applications. XML Gateway enables you to create an efficient and responsive supply chain that links all customers, factories, warehouses, distributors, carriers, and other trading partners. All these entities can seamlessly operate as a single enterprise.

Oracle XML Gateway supports both Business-to-Business (B2B) and Application-to-Application (A2A) initiatives. B2B initiatives include communicating business documents and participating in industry exchanges. An example of an A2A initiative is data integration with legacy and disparate systems.

XML Gateway enables bidirectional integration with Oracle Applications by allowing you to insert and retrieve data from Oracle Applications. The Oracle Applications adapter for XML Gateway supports inbound and outbound XML Gateway message processing. For XML Gateway inbound message processing, the inbound message will be placed in the ECX\_INBOUND queue. Agent Listeners running on ECX\_INBOUND would enable further processing by the Execution Engine. Oracle XML Gateway picks this XML message, does trading partner validation, and inserts data into Oracle Applications. For XML Gateway outbound message processing, the outbound message will be first enqueued to the ECX\_OUTBOUND queue. Oracle BPEL PM listens to ECX\_OUTBOUND queue for the message with the same correlation Id BPEL. The message will then be dequeued to retrieve outbound data from Oracle E-Business Suite. The retrieved data can be passed to trading partners or consumers who subscribed to the message.

**XML Gateway Integration Architecture**

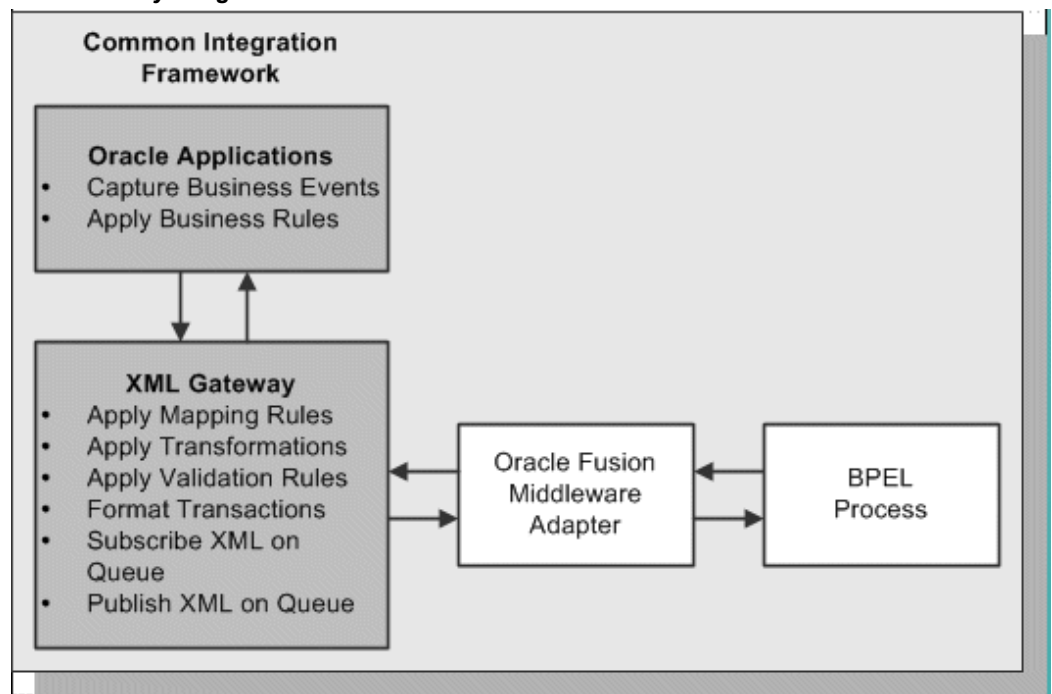

**Message Queues**

The XML Gateway uses queues specifically at two points in the process as well as employing a general error queue. The first point is at the transport agent level between the transport agent module and the XML Gateway. The second point is at the transaction level between base Oracle Applications products and the XML Gateway.

**Inbound Queues**

Inbound message queues are used for XML messages inbound into Oracle Applications.

Inbound message queues are positioned between the Transport Agent and the Oracle Workflow Business Event System.

The messages must be formatted according to the XML Gateway envelope message format. The envelope message format is discussed under XML Gateway Envelope, page 5-4. Oracle Workflow Business Event System copies the inbound messages to the proper inbound Transaction Queue.

## Outbound Queues

Outbound message queues are used for XML messages outbound from Oracle Applications. The outbound Message Queue is positioned between the XML Gateway and the Transport Agent.

The XML Gateway creates XML messages, then enqueues them on this queue. The Transport Agent dequeues the message and delivers it to the Trading Partner.

## XML Gateway Envelope

In addition to the business document such as a purchase order or invoice in the XML Payload, a set of message attributes are also transmitted. Collectively, these attributes are called the XML Gateway envelope. The following table describes some of these attributes.

### *Envelope Attributes*

<b>Attribute</b>	<b>Description</b>
MESSAGE_TYPE	Payload message format. This defaults to XML. Oracle XML Gateway currently supports only XML.
MESSAGE_STANDARD	Message format standard as displayed in the Define Transactions form and entered in the Define XML Standards form. This defaults to OAG. The message standard entered for an inbound XML document must be the same as the message standard in the trading partner setup.
TRANSACTION_TYPE	External Transaction Type for the business document from the Trading Partner table. The transaction type for an inbound XML document must be the same as the transaction type defined in the Trading Partner form.

Attribute	Description
TRANSACTION_SUBTYPE	External Transaction Subtype for the business document from the Trading Partner table. The transaction subtype for an inbound XML document must be the same as the transaction subtype defined in the Trading Partner form.
DOCUMENT_NUMBER	The document identifier used to identify the transaction, such as a purchase order or invoice number. This field is not used by the XML Gateway, but it may be passed on inbound messages.
PROTOCOL_TYPE	Transmission Protocol as defined in the Trading Partner table.
PROTOCOL_ADDRESS	Transmission address as defined in the Trading Partner table.
USERNAME	USERNAME as defined in the Trading Partner table.
PASSWORD	The password associated with the USERNAME defined in the Trading Partner table.
PARTY_SITE_ID	The party site identifier for an inbound XML document must be the same as the Source Trading Partner location defined in the Trading Partner form.
ATTRIBUTE3	<p>For outbound messages, this field has the value from the Destination Trading Partner Location Code in the Trading Partner table. For inbound messages, the presence of this value generates another XML message that is sent to the trading partner identified in the Destination Trading Partner Location Code in the Trading Partner table. This value must be recognized by the hub to forward the XML message to the final recipient of the XML Message.</p> <p><b>Note:</b> For more information, see <i>Destination Trading Partner Location Code</i> in the <i>Oracle XML Gateway User's Guide</i>. This guide is part of the Oracle E-Business Suite Documentation Library which can be accessed on the Oracle Technology Network (OTN).</p>

Attribute	Description
PAYLOAD	The XML message.

### Parameters defined by the Application

The following parameters may be defined by the base application:

- ATTRIBUTE1
- ATTRIBUTE2
- ATTRIBUTE4
- ATTRIBUTE5

### Parameters Not Used

The following parameters are not used:

- PARTYID
- PARTYTYPE

**Note:** See *Oracle XML Gateway User's Guide* for details on the XML Gateway Execution Engine, Trading Partner validation, and other XML Gateway information. This guide is part of the Oracle E-Business Suite Documentation Library which can be accessed on the Oracle Technology Network (OTN).

## Design-Time Tasks for XML Gateway Inbound Messaging

This section describes configuring the Adapter for Oracle Applications to use XML Gateway. It describes the tasks required to configure Adapter for Oracle Applications using the Adapter Configuration Wizard in Oracle JDeveloper.

### SOA Composite Application with BPEL Process Scenario

Take the XML Gateway Inbound Process PO XML Transaction as an example to explain the BPEL process creation. In this example, the XML Gateway inbound message map is exposed as a Web service through `PROCESS_PO_007` inbound map. It allows sales order data including header and line items to be inserted into Order Management system while an associated purchase order is created.

When a purchase order is sent by a trading partner, the purchase order data is used as input to the BPEL process along with ECX Header properties such as



`jca.apps.ecx.TransactionType`. The BPEL process then pushes this purchase order in ECX\_INBOUND queue. Agent Listeners running on ECX\_INBOUND would enable further processing by the Execution Engine. Oracle XML Gateway picks this XML message, does trading partner validation, and inserts order data to Order Management Application.

When the SOA Composite application with BPEL process has been successfully executed after deployment, you should get the same order information inserted into the Order Management table once a purchase order is created.

## **Prerequisites to Configure XML Gateway Inbound**

### *Setting XML Gateway Header Properties*

You need to populate certain variables in the BPEL process in order to provide context information for Oracle Applications. This is accomplished by setting individual fields as header properties from the `SYSTEM.ECXMSG` object used in earlier releases.

The header properties can include, for example, `jca.apps.ecx.TransactionType`, `jca.apps.ecx.TransactionSubtype`, `jca.apps.ecx.PartySiteId`, `jca.apps.ecx.MessageType`, `jca.apps.ecx.MessageStandard`, `jca.apps.ecx.DocumentNumber` that you need to populate for the XML transaction to complete successfully.

These header property values can be defined through the Properties tab of an Invoke activity. See *Configure the Invoke activity*, page 5-26 for more information.

### *Setting Up XML Gateway Trading Partner*

You need to ensure that you have defined a valid inbound XML Gateway trading partner in the Trading Partner Setup form through XML Gateway responsibility.

For example, a Trading Partner (such as 'Business World' with Site information '2391 L Street San Jose CA 95106' and partner type 'Customer') has the following details for an inbound transaction:

- Transaction type: ONT
- Transaction sub type: POI
- Standard Code: OAG
- External transaction type: PO
- External transaction subtype: PROCESS
- Direction: IN
- Map: ONT\_3A4R\_OAG72\_IN
- Source Trading partner location code: BWSANJOSE

### *Ensuring Agent Listeners Are All Up and Running*

You also need to configure and schedule two listeners on the Oracle Applications side. These are the ECX Inbound Agent Listener and the ECX Transaction Agent Listener. Use the following steps to configure these listeners in Oracle Applications:

1. Log in to Oracle Applications with the responsibility of Workflow Administrator.
2. Select the **Workflow Administrator Web Applications** link from the Navigator.
3. Click the **Workflow Manager** link under Oracle Applications Manager.
4. Click the status icon next to **Agent Listeners**.
5. Configure and schedule the **ECX Inbound Agent Listener**, **ECX Transaction Agent Listener**, and the **Workflow Deferred Agent Listener**. Select the listener, and select Start from the **Actions** box. Click **Go**.

Based on the XML Gateway Inbound Process PO XML Transaction business scenario, the following design-time tasks are discussed in this chapter:

1. Create a new SOA Composite application with BPEL process, page 5-8.
2. Create a partner link, page 5-12.
3. Add partner links for file adapter, page 5-22.
4. Configure Invoke activities, page 5-26.
5. Configure an Assign activity, page 5-33.

## Creating a New SOA Composite Application with BPEL Process

**To create a new SOA Composite application with BPEL process:**

1. Launch Oracle JDeveloper.
2. Click **New Application** in the Application Navigator.

The Create SOA Application - Name your application page is displayed.

### The Create SOA Application - Name your application Page

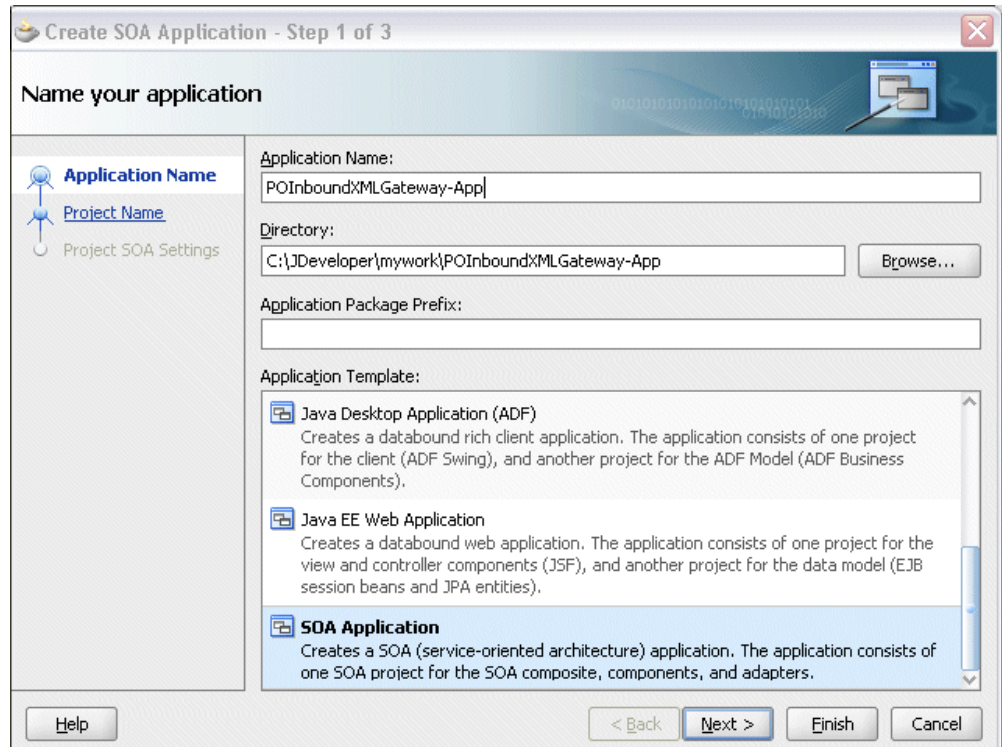

3. Enter an appropriate name for the application in the **Application Name** field and select **SOA Application** from the Application Template list.

Click **Next**. The Create SOA Application - Name your project page is displayed.

### The Create SOA Application - Name your project Page

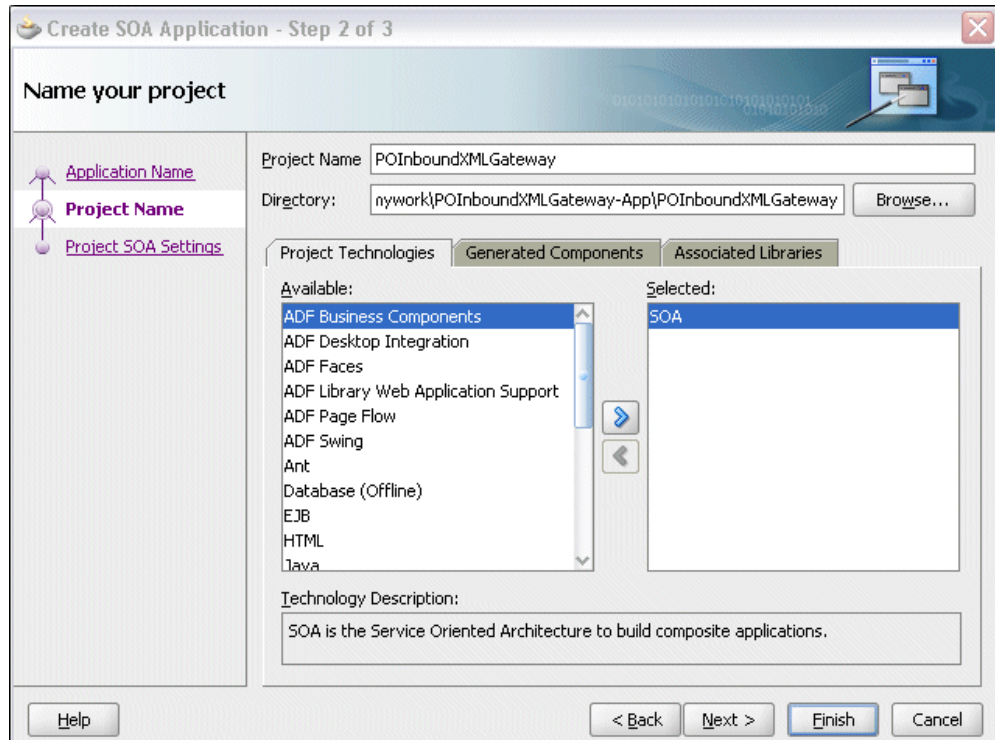

4. Enter an appropriate name for the project in the **Project Name** field. For example, POInboundXMLGateway.
5. In the Project Technologies tab, ensure that **SOA** is selected from the Available technology list to the Selected technology list.

Click **Next**. The Create SOA Application - Configure SOA settings page is displayed.

### The Create SOA Application - Configure SOA settings Page

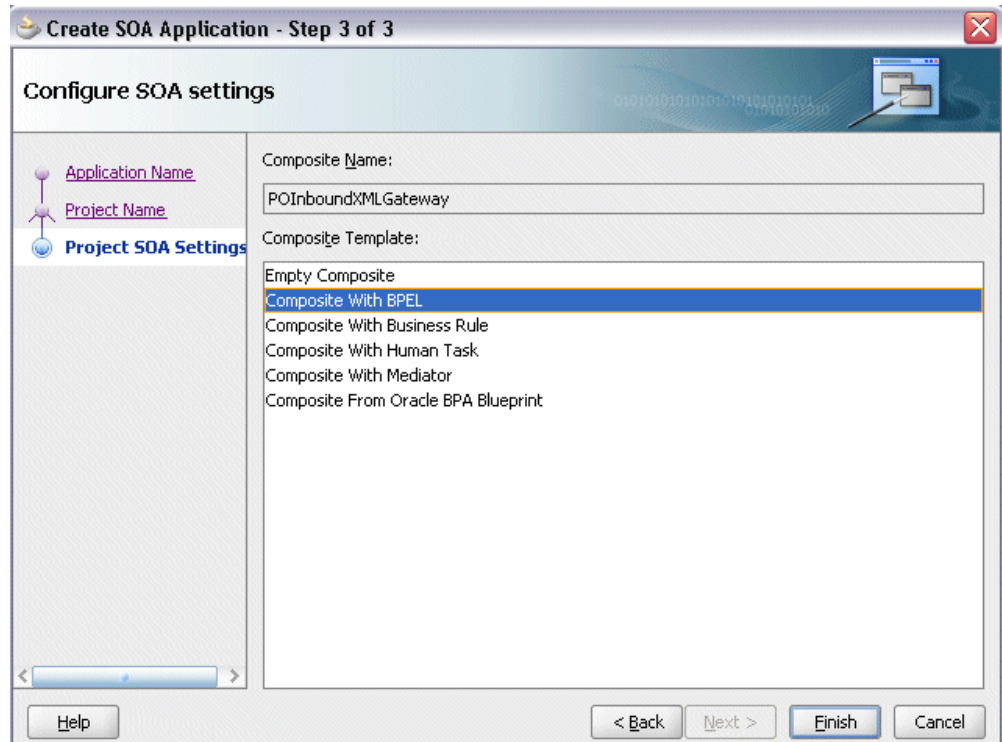

6. Select **Composite With BPEL** from the Composite Template list, and then click **Finish**. You have created a new application, and a SOA project. This automatically creates a SOA Composite.

The Create BPEL Process page is displayed.

### The Create BPEL Process Page

**BPEL Process**

A BPEL process is a service orchestration, based on the BPEL specification, used to describe/execute a business process (or large grained service), which is implemented as a stateful service.

BPEL 1.1 Specification  BPEL 2.0 Specification

Name: POInboundXMLGateway

Namespace: http://xmlns.oracle.com/POInboundXMLGateway/POInboundXMLGateway/POInboundXMLGateway

Template: Asynchronous BPEL Process

Service Name: poinboundxmlgateway\_client

Expose as a SOAP service

Delivery: async.persist

Input: xm/POInboundXMLGateway/POInboundXMLGateway/POInboundXMLGateway}process

Output: bundXMLGateway/POInboundXMLGateway/POInboundXMLGateway}processResponse

Help OK Cancel

7. Leave the default **BPEL 1.1 Specification** selection unchanged. This creates a BPEL project that supports the BPEL 1.1 specification.

Enter an appropriate name for the BPEL process in the **Name** field. For example, POInboundXMLGateway.

Select **Asynchronous BPEL Process** in the **Template** field. Click **OK**.

An asynchronous BPEL process is created with the Receive and Reply activities. The required source files including bpel and wsdl, using the name you specified (for example, POInboundXMLGateway.bpel and POInboundXMLGateway.wsdl ) and composite.xml are also generated.

## Creating a Partner Link

The next task is to add a partner link to the BPEL process. A partner link defines the link name, type, and the role of the BPEL process that interacts with the partner service.

### To add a partner link:

1. Click **BPEL Services** in the Component palette.

Drag and drop **Oracle Applications** from the **BPEL Services** list into the right Partner Link swim lane of the process diagram. The Adapter Configuration Wizard Welcome page appears. Click **Next**.

2. Enter a service name in the **Service Name** field. For example, XMLGatewayOrderInbound.

Click **Next**. The Service Connection dialog appears.

### Specifying a Database Service Connection

Adapter Configuration Wizard - Step 3 of 4

#### Service Connection

A Database Connection is required to configure this adapter. Select a database connection already defined in your project or create a New Connection.

Connection: OracleAppsConnection

User Name: apps

Driver: oracle.jdbc.OracleDriver

Connect String: jdbc:oracle:thin:@localhost:1521:sid01

Specify the JNDI name for the database. Note: The deployment descriptor of the Oracle Applications adapter must associate this JNDI name with configuration properties required by the adapter to access the database.

JNDI Name: eis/Apps/OracleAppsConnection

Help < Back Next > Finish Cancel

3. You can either create a new database connection or use an existing connection.

**Note:** You need to connect to the database where Oracle Applications is running.

- **Creating a New Database Connection:**

Complete the following steps to create a new database connection:

1. From the Service Connection page, click the **Create a New Database Connection** icon.

The Create Database Connection page appears.

### Creating a Database Connection

Configure a new database connection and add it to the current application (test1).

Create Connection In:  Application Resources  IDE Connections

Connection Name:

Connection Type:

Username:  Role:

Password:   Save Password

- Oracle (JDBC) Settings -

Enter Custom JDBC URL

Driver:

Host Name:  JDBC Port:

SID:

Service Name:

2. Enter the following information:
  1. In the **Connection Name** field, specify a unique name for the database connection.
  2. From the **Connection Type** list, select the type of connection for your database (such as Oracle (JDBC)).
  3. In the **UserName** field, specify a unique name for the database connection.
  4. In the **Password** field, specify a password for the database connection.
  5. In the Oracle (JDBC) Settings, from the **Driver** list, select **Thin**.



6. In the **Host Name** field, specify the host name for the database connection.
  7. In the **JDBC Port** field, specify the port number for the database connection.
  8. In the **SID** field, specify the unique SID value for the database connection.
3. Click **Test Connection** to determine whether the specified information establishes a connection with the database.
- The status message "Success!" indicates a valid connection.
- Click **OK**.
4. The Service Connection dialog box appears, providing a summary of your database connection.

## New Database Connection

**Service Connection**

A Database Connection is required to configure this adapter. Select a database connection already defined in your project or create a New Connection.

Connection: OracleAppsConnection

User Name: apps

Driver: oracle.jdbc.OracleDriver

Connect String: jdbc:oracle:thin:@localhost:1521:sid01

Specify the JNDI name for the database. Note: The deployment descriptor of the Oracle Applications adapter must associate this JNDI name with configuration properties required by the adapter to access the database.

JNDI Name: eis/Apps/OracleAppsConnection

Help < Back Next > Finish Cancel

- **Selecting an Existing Database Connection:**

Instead of creating a new database connection, you can use an existing database connection that you have configured.

1. From the Service Connection page, select an appropriate connection from the **Connection** drop-down list.
2. The Service Connection page will be displayed with the selected connection information. The JNDI (Java Naming and Directory Interface) name corresponding to the database connection appears automatically in the **Database Server JNDI Name** field. Alternatively, you can specify a JNDI name.

**Note:** When you specify a JNDI name, the deployment descriptor of the Oracle Applications adapter must associate this JNDI name with configuration properties required by the adapter to access the database.

The JNDI name acts as a placeholder for the connection used when your service is deployed to the BPEL server. This enables you to use different

databases for development and later for production.

**Note:** For more information about JNDI concepts, refer to *Oracle Fusion Middleware User's Guide for Technology Adapters*.

4. Once you have completed a new connection or selected an existing connection, you can add an XML Gateway inbound map by browsing through the list of APIs available in Oracle Applications.

Click **Next**.

**For Oracle E-Business Suite Release 12:**

If you are connecting to Oracle E-Business Suite Release 12, then the **IREP File not present** dialog appears indicating that Adapter could not find the Oracle Integration Repository data file corresponding to the database you are connecting in your workspace. Absence of the data file would make browsing or searching of Integration Repository tree considerably slow. You can choose to extract the data file and create a local copy of the Integration Repository data file. Once it is created successfully, Adapter will pick it up automatically next time and retrieve data from your local Integration Repository.

You can select one of the following options:

- Click **Yes** to extract the Integration Repository data file.

### Extracting Integration Repository Data File

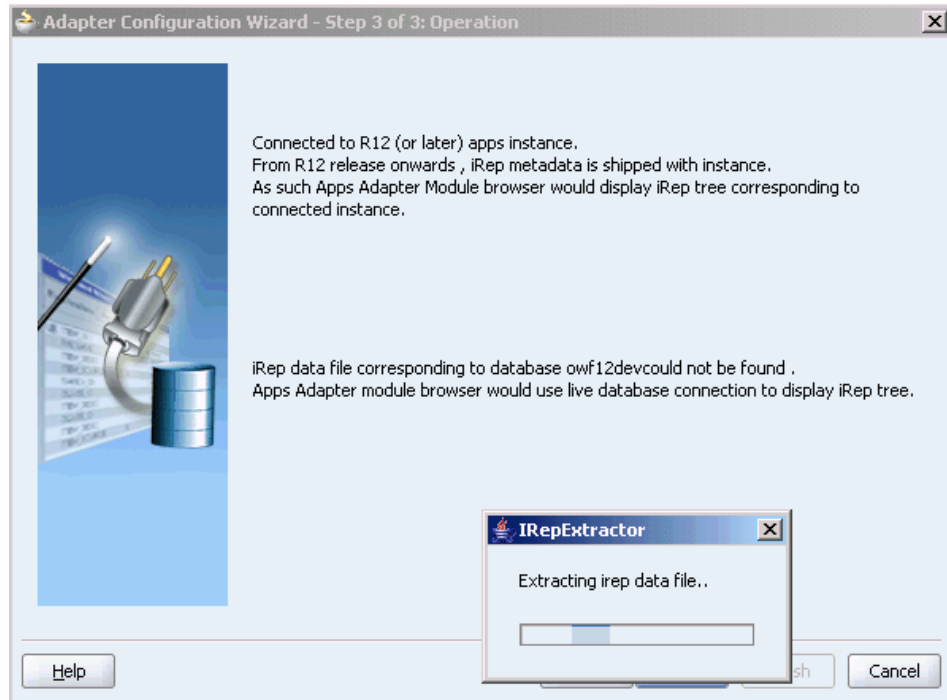

After the system successfully creates a local copy of the Integration Repository data file, next time when you connect to the database, you will find the **IRep Data File** field appears in the Operation dialog indicating where your local copy exists with the creation date and time as part of the file name.

### Using the Local Integration Repository Data File

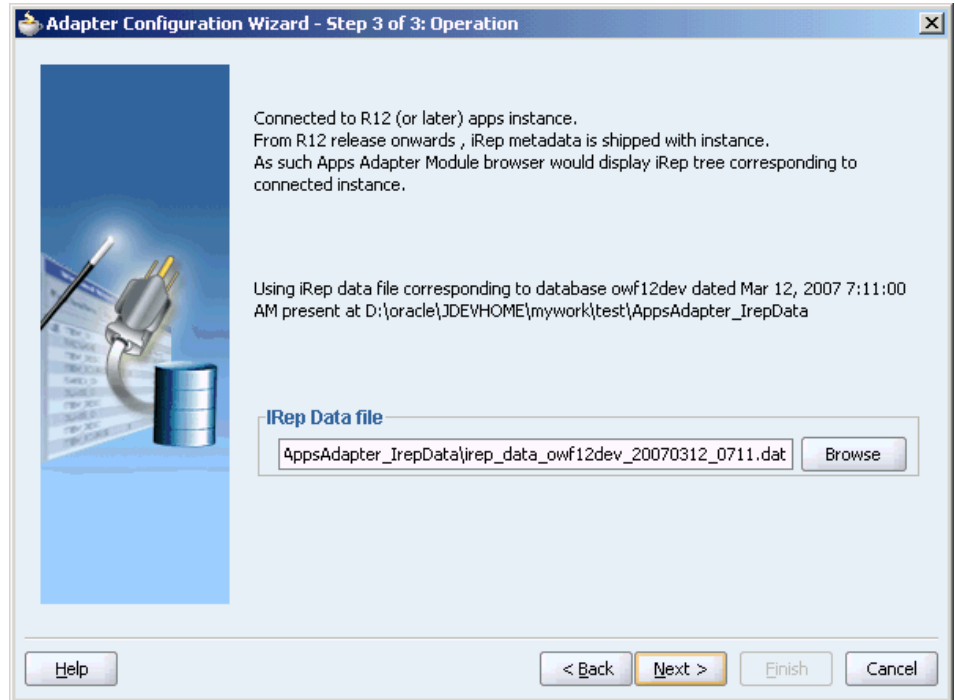

- Click **No** to query the Integration Repository data file from the live database you are connecting to display the Integration Repository tree.

Click **Next** in the Operation page to open the Oracle Applications Module Browser.

#### **For Oracle E-Business Suite Release 11.5.9:**

If you are connecting to an Oracle E-Business Suite Release 11.5.9 instance, you must select the interface type in the Adapter Configuration Wizard. Select **XML Gateway** to proceed.

Click **Get Object** in the Application Interface dialog to open the Oracle Applications Module Browser.

5. The Oracle Applications Module Browser combines interface data from Oracle Integration Repository with information about the additional interfaces supported by Oracle Application Adapter, organized in a tree hierarchy.

## Specify an Inbound XML Gateway Message Map from The Oracle Applications Module Browser

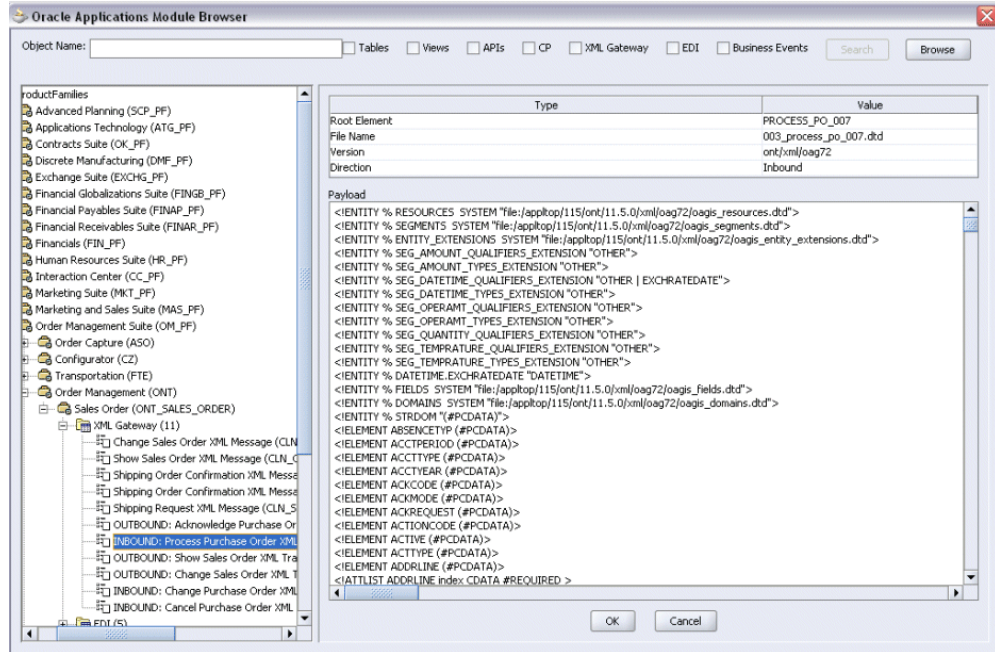

**Note:** The Oracle Applications Module Browser includes the various product families that are available in Oracle Applications. Each product family contains the individual products. Each product contains the business entities associated with the product. Business entities contain the various application modules that are exposed for integration. These modules are grouped according to the interface they provide.

Navigate to *Order Management Suite > Order Management > Sales Order > XML Gateway* to select *Inbound: Process Purchase Order XML Transaction (ONT\_3A4R\_OAG72\_IN)*.

6. Click **OK**.

### Adapter Configuration Wizard - Application Interface Page

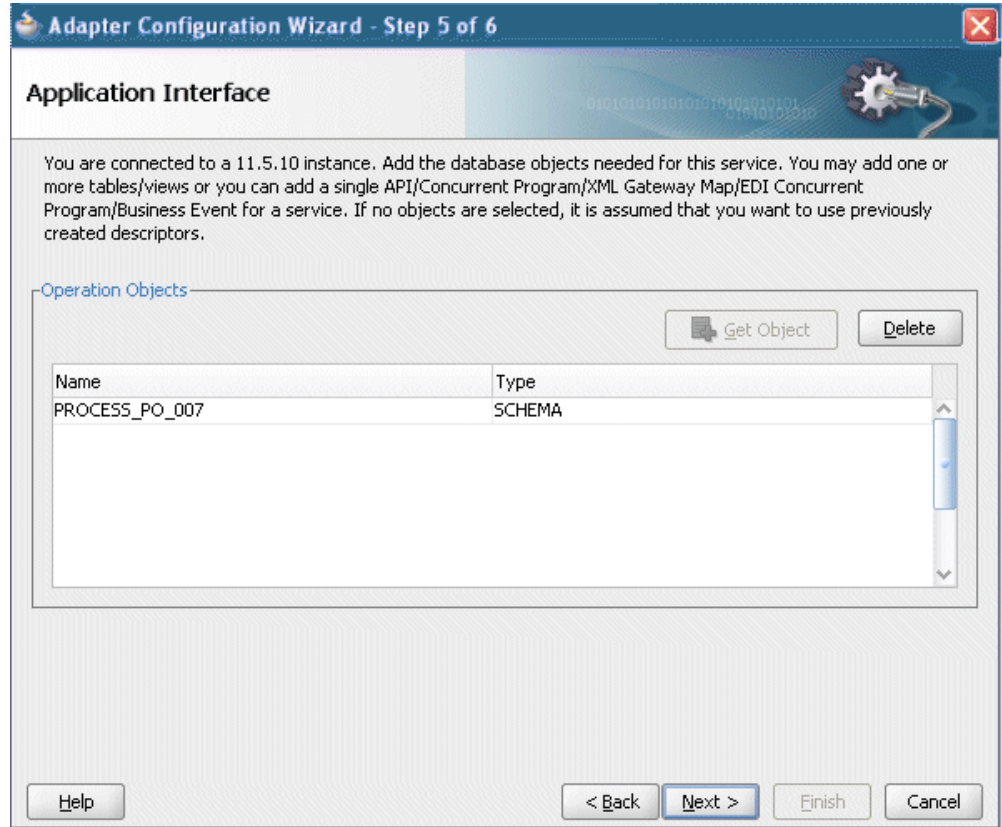

7. Click **Next**, then click **Finish** to complete the process of configuring Adapter for Oracle Applications.

The wizard generates the WSDL file corresponding to the XML schema. This WSDL file is now available for the partner link.

8. Click **Apply** and then **OK**. The partner link is created with the required WSDL settings.

After adding and configuring the partner link, the next task is to configure the BPEL process.

### Partner Link Information

The screenshot shows the 'Create Partner Link' dialog box with the following configuration:

- Name:** XMLGatewayOrderInbound
- Process:** (empty)
- WSDL Settings:**
  - WSDL URL:** XMLGatewayOrderInbound.wsdl
  - Partner Link Type:** Enqueue\_plt
  - Partner Role:** Enqueue\_role
  - My Role:** ---- Not Specified ----

## Adding a Partner Link for the File Adapter

If you are configuring an inbound message, then you would need to add another partner link for the file adapter. This allows the inbound message to pick up an XML file received from the third party application. The data is inserted into Oracle Applications through the partner link that was configured earlier.

### To add a partner link for the file adapter to get the XML Message:

1. In JDeveloper BPEL Designer, click **BPEL Services** in the Component palette.  
Drag and drop **File Adapter** from the BPEL Services list into the right Partner Link swim lane of the process diagram. The Adapter Configuration Wizard Welcome page appears.  
Click **Next**.
2. In the Service Name page, enter a name for the file adapter service, for example, getOrderXML.
3. Click **Next**. The Adapter Interface page appears.



## Specifying the Adapter Interface

**Adapter Interface**

The adapter interface is defined by a wsdl that is generated using the operation name and schema(s) specified later in this wizard. Optionally, the adapter interface may be defined by importing an existing WSDL.

Interface:  Define from operation and schema (specified later)

Import an existing WSDL

WSDL URL:

Port Type:

Operation:

Help < Back Next > Finish Cancel

Select the **Define from operation and schema (specified later)** radio button and click **Next**.

4. In the Operation page, specify the operation type. For example, select the **Synchronous Read File** radio button. This automatically populates the **Operation Name** field.

### Specifying the Operation

The screenshot shows a window titled "Adapter Configuration Wizard - Step 4 of 8". The main heading is "Operation". Below the heading, there is a descriptive paragraph: "The File Adapter supports four operations. There is a Read File operation that polls for incoming files in your local file system, a Write File operation that creates outgoing files, a Synchronous Read File operation that reads the current contents of a file, and a List Files operation that lists file names in specified locations. Specify the Operation type and Operation Name. Only one operation per Adapter Service may be defined using this wizard." Below this text, there are four radio button options under the label "Operation Type": "Read File", "Write File", "Synchronous Read File" (which is selected), and "List Files". Below the radio buttons, there is a text input field labeled "Operation Name:" containing the text "SynchRead". At the bottom of the window, there are four buttons: "Help", "< Back", "Next >" (which is highlighted in blue), "Finish", and "Cancel".

Click **Next** to access the File Directories page.

5. Select the **Logical Name** radio button and specify directory for incoming files, such as `inputDir`.

Ensure the **Delete files after successful retrieval** check box is not selected.

## Configuring the Input File

The screenshot shows a window titled "Adapter Configuration Wizard - Step 5 of 8" with a close button in the top right corner. The main heading is "File Directories". Below the heading, there is a sub-heading: "Enter directory information for the incoming file of the Synchronous Read File operation." Below this, there are two radio buttons: "Physical Path" (unselected) and "Logical Name" (selected). A text box labeled "Directory for Incoming Files (logical name):" contains the text "inputDir". Below this, there are two checkboxes: "Archive processed files" (unselected) and "Delete files after successful retrieval" (unselected). The "Delete files after successful retrieval" checkbox is highlighted with a yellow border. Below the checkboxes, there is a text box labeled "Archive Directory for Processed Files (logical name):" which is empty. At the bottom of the window, there are four buttons: "Help", "< Back", "Next >", and "Cancel".

Click **Next** to open the File Name page.

6. Enter the name of the file for the synchronous read file operation. For example, enter `order_data_xmlg.xml`.

**Note:** Use the following information to edit `composite.xml` to specify the physical directory for the File Adapter:

```
<property name="inputDir" type="xs:string"
many="false" override="may"/>/usr/tmp/</property>
```

Click **Next**. The Messages page appears.

7. Select the 'browse for schema file' icon to open the Type Chooser window.

Expand the node by clicking **Project Schema Files > PROCESS\_PO\_007.xsd > PROCESS\_PO\_007**.

The selected schema information will be automatically populated in the URL and Schema Element fields.

## Specifying Message Schema

Adapter Configuration Wizard - Step 7 of 8

### Messages

Define the message for the Synchronous Read File operation. Specify the Schema File Location and select the Schema Element that defines the messages in the incoming files. Use the Browse button to find an existing schema definition. If you check 'Schema is Opaque', then you do not need to specify a Schema.

**Message Schema**

Native format translation is not required (Schema is Opaque)

Define Schema for Native Format

URL:

Schema Element:

Help < Back Next > Finish Cancel

8. Click **Next** and then **Finish**. The wizard generates the WSDL file corresponding to the partner link. The main Create Partner Link dialog box appears, specifying the new WSDL file `getOrderXML.wsdl`.

Click **Apply** and **OK** to complete the configuration and create the partner link with the required WSDL settings for the File Adapter service.

The `getOrderXML` Partner Link appears in the BPEL process diagram.

## Configuring the Invoke Activities

After adding and configuring the partner link, the next task is to configure the BPEL process. You can start by configuring the **Invoke** process activity to enqueue the XML Gateway inbound messages and set XML Gateway header properties.

Based on the scenario described earlier, you need to configure the following two Invoke activities:

1. To get the XML message details from the input XML file through synchronous read operation by invoking the `getOrderXML` partner link.

2. To enqueue the purchase order information to the ECX\_INBOUND queue by invoking XMLGatewayOrderInbound partner link in an XML file.

The ECX Header properties for the XML Gateway inbound service can also be set through the Invoke activity.

### To configure the first Invoke activity:

1. In Oracle JDeveloper BPEL Designer, expand the **BPEL Constructs** from the Component Palette. Drag and drop the first **Invoke** activity into the center swim lane of the process diagram, between the **receiveInput** and **callbackClient** activities.
2. Link the Invoke activity to the `getOrderXML` partner link service.

#### Creating an Invoke Activity

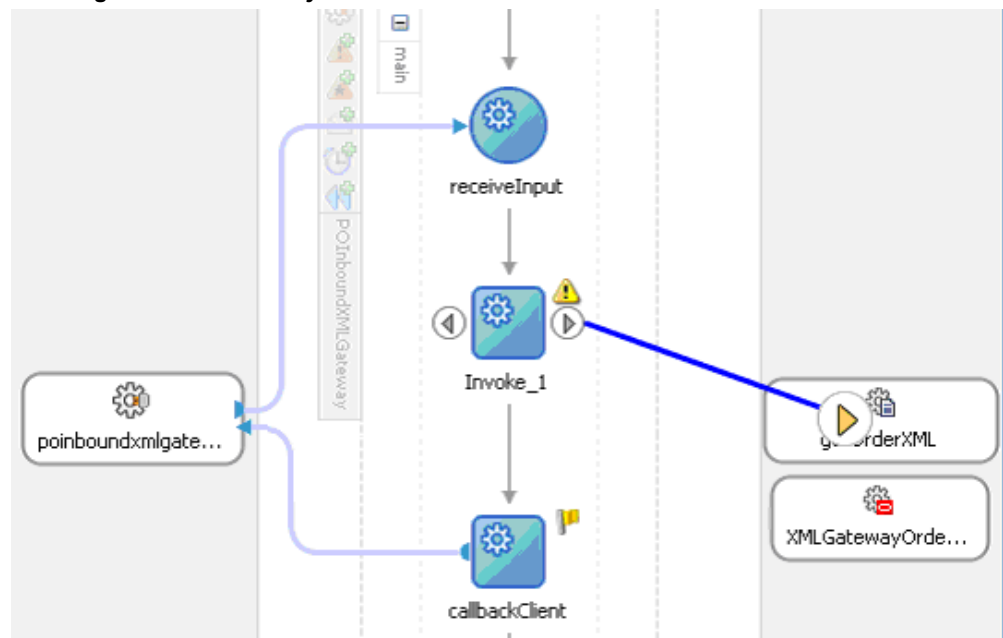

3. In the Edit Invoke dialog, enter a name for the Invoke activity in the General tab. The value of the Operation field is automatically selected based on the associated partner link. For example, this Invoke activity is to invoke a File Adapter service to synchronize read an input XML file; thus, the `SynchRead` is automatically populated in the Operation field.
4. Click the **Create** icon next to the **Input Variable** field. The Create Variable dialog appears. Select **Global Variable** and enter a name for the variable. You can also accept the default name. Click **OK**.

5. In the Edit Invoke dialog, click the **Create** icon next to the **Output Variable** field to create a new variable. The Create Variable dialog box appears.

#### *Creating the Input Variable*

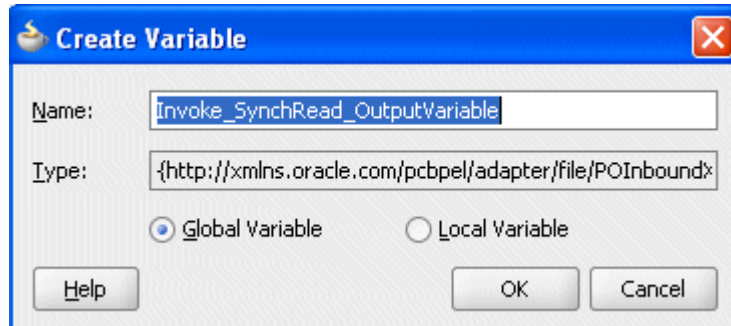

Select **Global Variable** and enter a name for the variable. You can also accept the default name. Click **OK** to return to the Edit Invoke dialog.

### The Edit Invoke Dialog

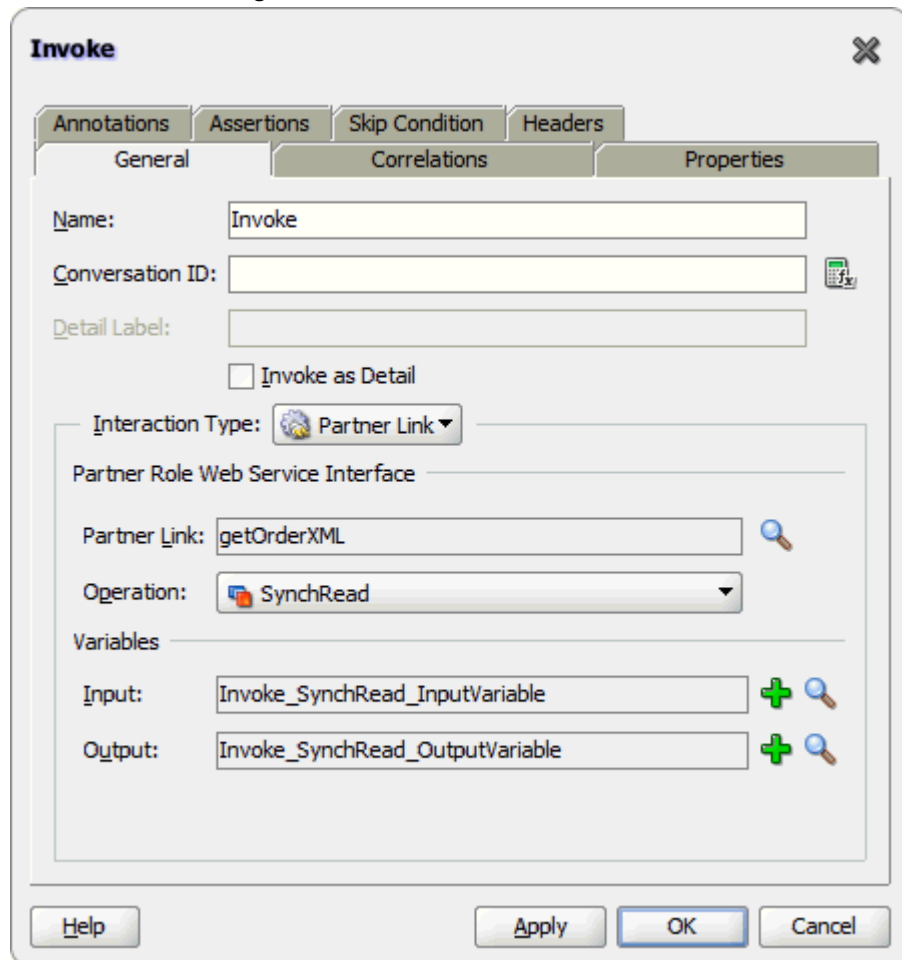

6. Click **Apply** and then **OK**.

### To configure the second Invoke activity:

1. In Oracle JDeveloper BPEL Designer, expand the **BPEL Constructs** from the Component Palette. Drag and drop the second **Invoke** activity into the center swim lane of the process diagram, between the first **Invoke** activity and **callbackClient** activity.
2. Link the Invoke activity to the XMLGatewayOrderInbound partner link service.
3. In the Edit Invoke dialog, enter a name for the Invoke activity in the General tab.  
The value of the Operation field is automatically selected based on the associated partner link. Since this Invoke activity is associated with an inbound message map partner link, the Enqueue operation is selected.

4. Click the **Create** icon next to the **Input Variable** field. The Create Variable dialog appears.

Select **Global Variable** and enter a name for the variable. You can also accept the default name. Click **OK**.

Click **Apply**.

#### The Edit Invoke Dialog

The screenshot shows the 'Invoke' dialog box with the following details:

- General Tab:**
  - Name: Invoke
  - Conversation ID: (empty)
  - Detail Label: (empty)
  - Invoke as Detail
  - Interaction Type: Partner Link
  - Partner Role Web Service Interface:
    - Partner Link: XMLGatewayOrderInbound
    - Operation: Enqueue
  - Variables:
    - Input: Invoke\_Enqueue\_InputVariable
    - Output: (empty)

#### 5. Setting ECX Header Message Properties

You need to enter appropriate XML Gateway header property values in order to pass individual message properties required for XML transaction to complete successfully.

Use the following steps to set ECX header message properties:

1. Click the **Properties** tab in the Invoke dialog box. You will find all predefined normalized message properties.



Locate XML Gateway specific properties with prefix `jca.apps.ecx` from the Properties tab.

2. Click a property first (such as `jca.apps.ecx.TransactionType`) from the Properties tab to enable the **Adapter Property Value** icon.
3. Click the icon to open the Adapter Property Value dialog.
4. Select the 'Expression' button as the message type.
5. Enter a property value for the selected property. For example, enter 'PO' for the property `jca.apps.ecx.TransactionType`.

### Entering a Selected Property Value

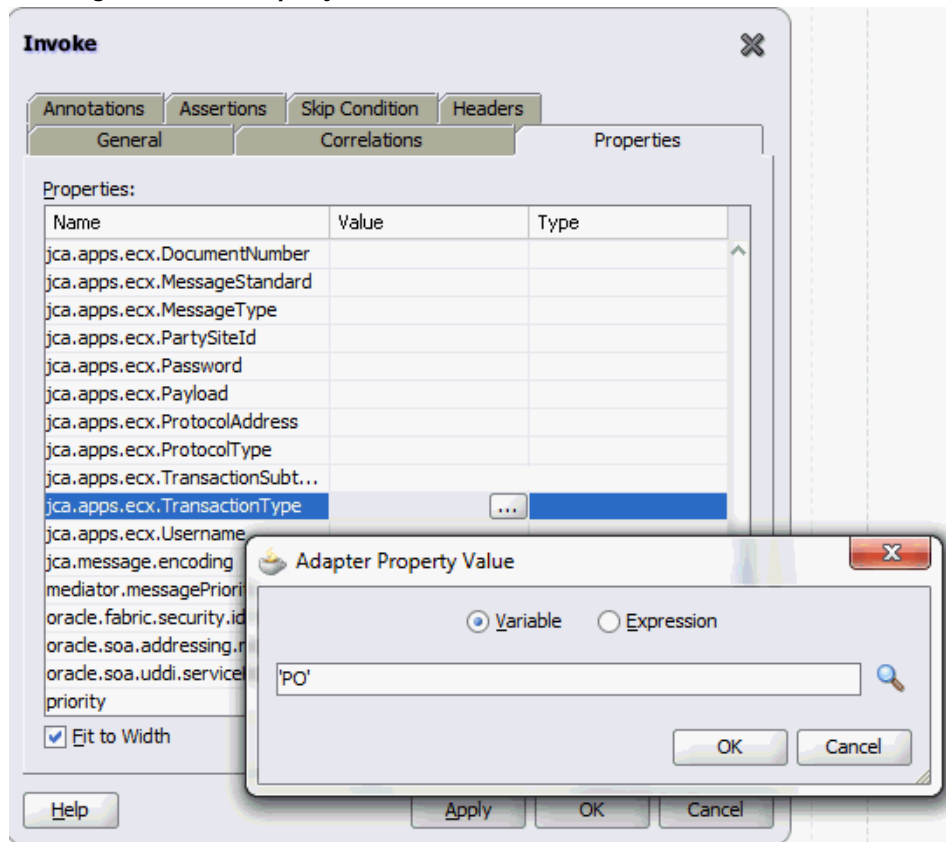

Click **OK**.

6. Repeat Step 2 to Step 5 to set the following property values:

- `jca.apps.ecx.MessageType: 'XML'`
- `jca.apps.ecx.TransactionSubType: 'PROCESS'`
- `jca.apps.ecx.PartySiteId: 'BWSANJOSE'`
- `jca.apps.ecx.MessageType: 'XML'`
- `jca.apps.ecx.MessageStandard: 'OAG'`
- `jca.apps.ecx.DocumentNumber: 'order_xml_01'`

**Note:** In earlier releases, XML Gateway header variables including `MESSAGE_TYPE`, `MESSAGE_STANDARD`,

TRANSACTION\_TYPE, TRANSACTION\_SUBTYPE, DOUCMENT\_NUMBER, and PARTY\_SITE\_ID are contained in the SYSTEM.ECXMSG object. Adapter for Oracle Applications now normalizes the SYSTEM.ECXMSG object to create and set each individual message property through the Properties tab of the Invoke activity. These header properties are required for the XML transaction to complete successfully.

6. In the Invoke dialog box, click **Apply** and then **OK**.

**Note:** If you have configured a partner link for outbound messages from Oracle Applications, then you need to configure a **Receive** activity in place of the **Invoke** activity. The **Receive** activity is used to dequeue the XML Gateway outbound messages.

## Configuring the Assign Activity

Use the Assign activity to pass the output of getOrderXML service as an input to the XMLGatewayOrderInbound service.

### To add an Assign activity:

1. In Oracle JDeveloper BPEL Designer, expand the **BPEL Constructs** from the Component Palette. Drag and drop the **Assign** activity into the center swim lane of the process diagram between the two **Invoke** activities you just created earlier.

2. Double-click the **Assign** activity to access the Edit Assign dialog.

Click the General tab to enter a name for the Assign activity. For example, SetOrderXML.

3. Select the Copy Rules tab and expand the target trees:

- In the From navigation tree, navigate to **Variable > Process > Variables > Invoke\_SynchRead\_OutputVariable** and select **body**.
- In the To navigation tree, navigate to **Variable > Process > Variables > Invoke\_Enqueue\_InputVariable** and select **PROCESS\_PO\_007**.

Drag the source node (body) to connect to the target node (PROCESS\_PO\_007) that you just specified. This creates a line that connects the source and target nodes. The copy rule is displayed in the From and To sections at the bottom of the Edit Assign dialog box.

## Assigning Parameters

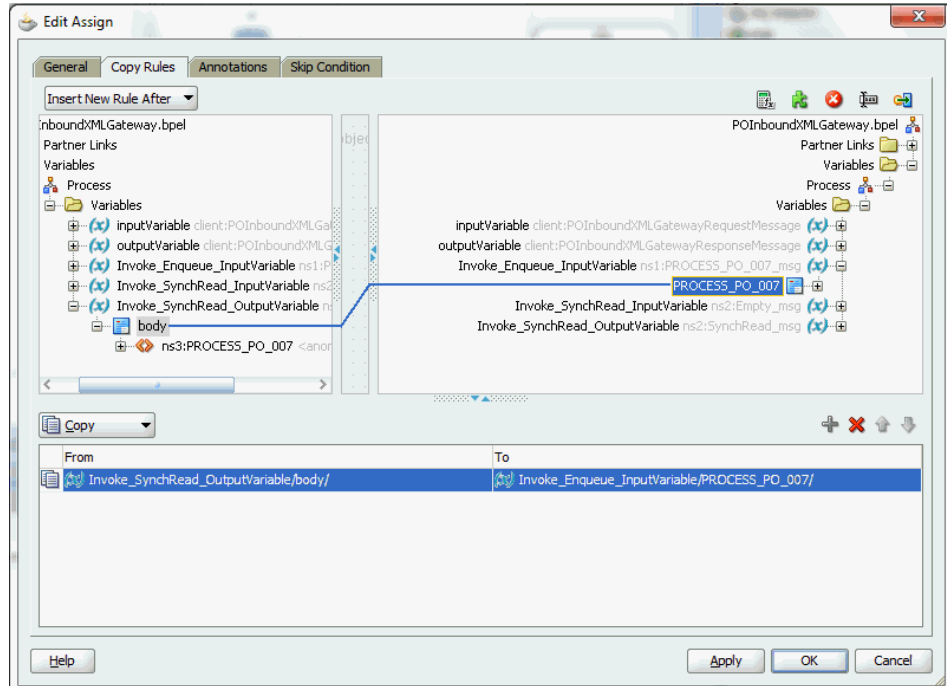

4. Click **Apply** and **OK** to complete the configuration of the Assign activity.

The following diagram illustrates the complete BPEL process:

### BPEL Process Diagram

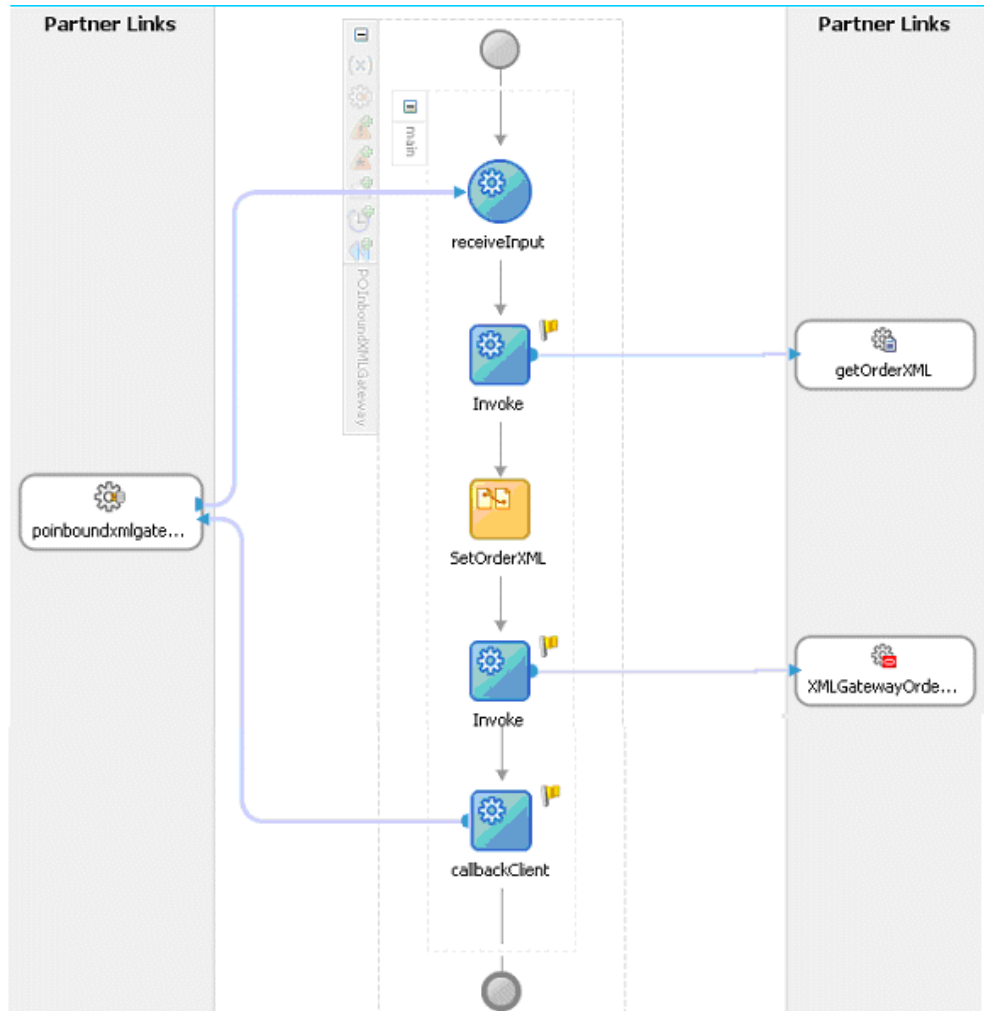

Click the `composite.xml` to display the Oracle JDeveloper composite diagram:

**Note:** Click the Source tab of `composite.xml` to enter a value for the `inputDir` (such as `/usr/tmp`).

```
<property name="inputDir" type="xs:string"
many="false" override="may">/usr/tmp</property>
```

### Oracle JDeveloper composite Diagram

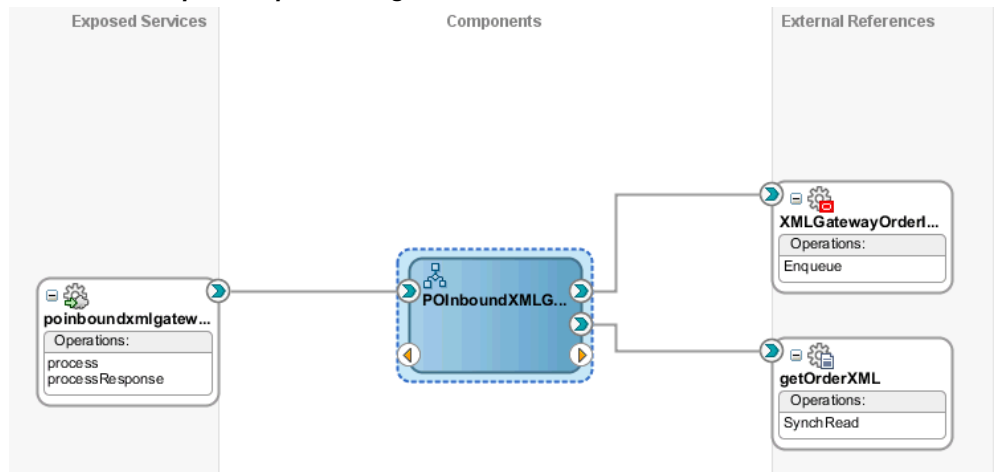

## Run-Time Tasks for XML Gateway Inbound Messaging

After designing the SOA Composite with BPEL process, the next step is to deploy, run and monitor it.

1. Deploy the SOA Composite application with BPEL process, page 5-36
2. Test the SOA Composite application with BPEL process, page 5-41
3. Verify records in OracleE-Business Suite, page 5-43

## Deploying the SOA Composite Application with BPEL Process

To invoke the XML Gateway inbound service from the BPEL client contained in the SOA composite, the SOA composite needs to be deployed to the Oracle WebLogic managed server. This can be achieved using Oracle JDeveloper. Once the composite is deployed, it can be tested from the Oracle Enterprise Manager Fusion Middleware Control Console.

### Prerequisites

Before deploying the SOA composite with BPEL process using Oracle JDeveloper, you must have established the connectivity between the design-time environment and the run-time server. For more information, see *Configuring the Data Source in Oracle WebLogic Server*, page A-3 and *Creating an Application Server Connection*, page A-12.

**Note:** If a local instance of the WebLogic Server is used, start the

WebLogic Server by selecting **Run > Start Server Instance** from Oracle JDeveloper. Once the WebLogic Admin Server "DefaultServer" instance is successfully started, the <Server started in Running mode> and DefaultServer started message in the Running:DefaultServer and Messages logs should appear.

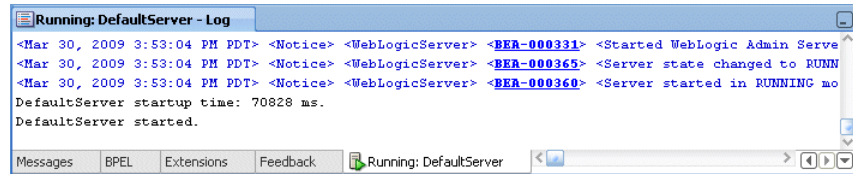

```
<Mar 30, 2009 3:53:04 PM PDT> <Notice> <WebLogicServer> <BEA-000331> <Started WebLogic Admin Serve
<Mar 30, 2009 3:53:04 PM PDT> <Notice> <WebLogicServer> <BEA-000365> <Server state changed to RUNN
<Mar 30, 2009 3:53:04 PM PDT> <Notice> <WebLogicServer> <BEA-000360> <Server started in RUNNING mo
DefaultServer startup time: 70828 ms.
DefaultServer started.
```

### To deploy the SOA Composite application with BPEL process:

1. Select the SOA Composite project in the Applications Navigator.
2. Right-click the project name. Select **Deploy > [project name] > [serverConnection]** from the menu that appears.

For example, you can select **Deploy > POInboundXMLGateway > soa-server1** to deploy the process if you have the connection set up appropriately.

### Deploying the SOA Composite with BPEL Process

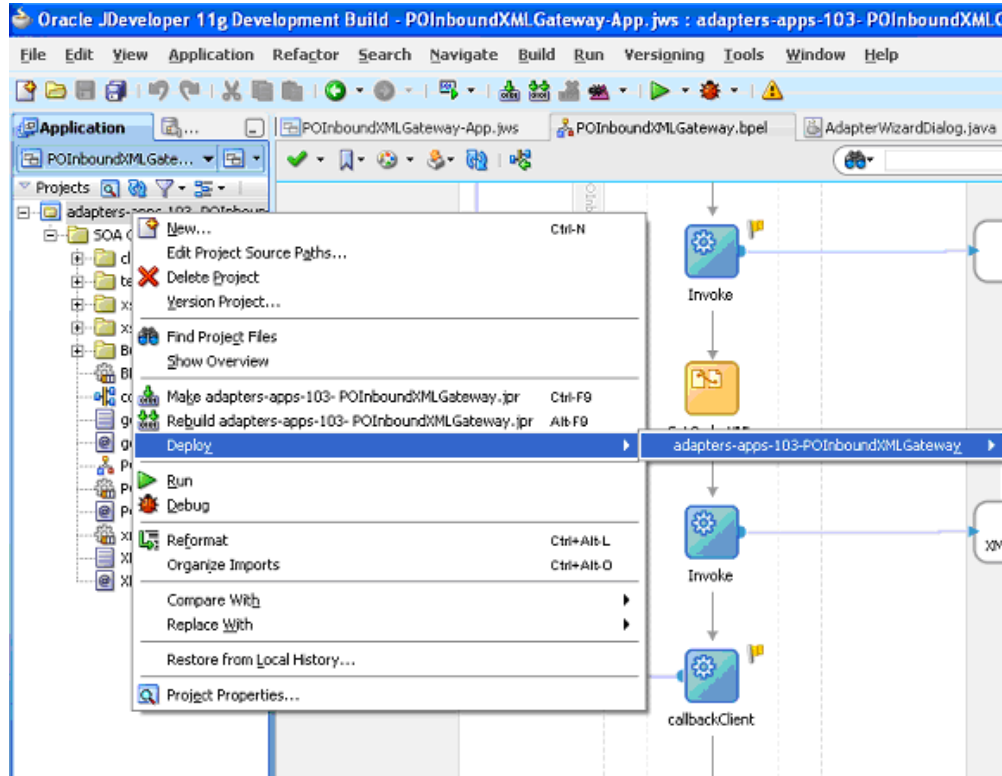

**Note:** If this is the first time to set up server connection, then the Deployment Action window appears. Select 'Deploy to Application Server' and click Next.



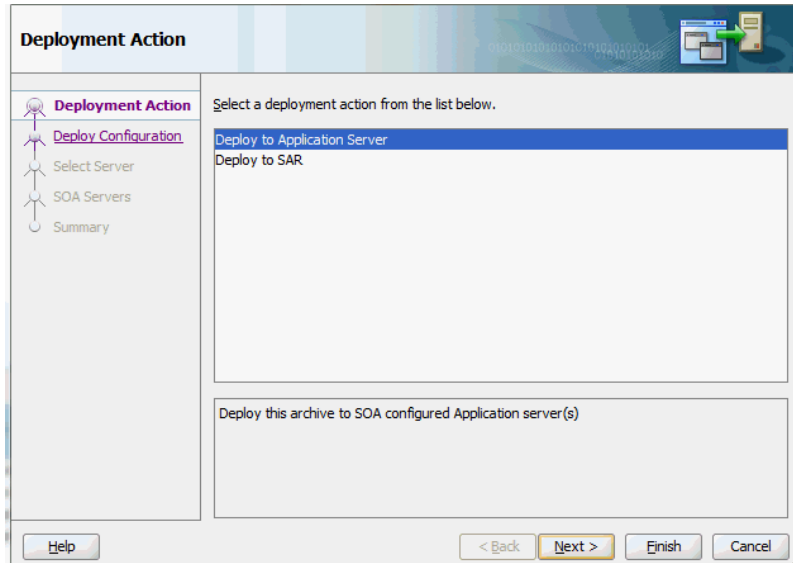

In the Deploy Configuration window, ensure the following information is selected before clicking **Next** to add a new application server:

- New Revision ID: 1.0
- Mark composite revision as default: Select this check box.
- Overwrite any existing composites with the same revision ID: Select this check box.

The steps to create a new Oracle WebLogic Server connection from JDeveloper are covered in [Creating an Application Server Connection](#), page A-12.

3. In the Select Server page, select 'soa-server1' that you have established the server connection earlier. Click **Next**.

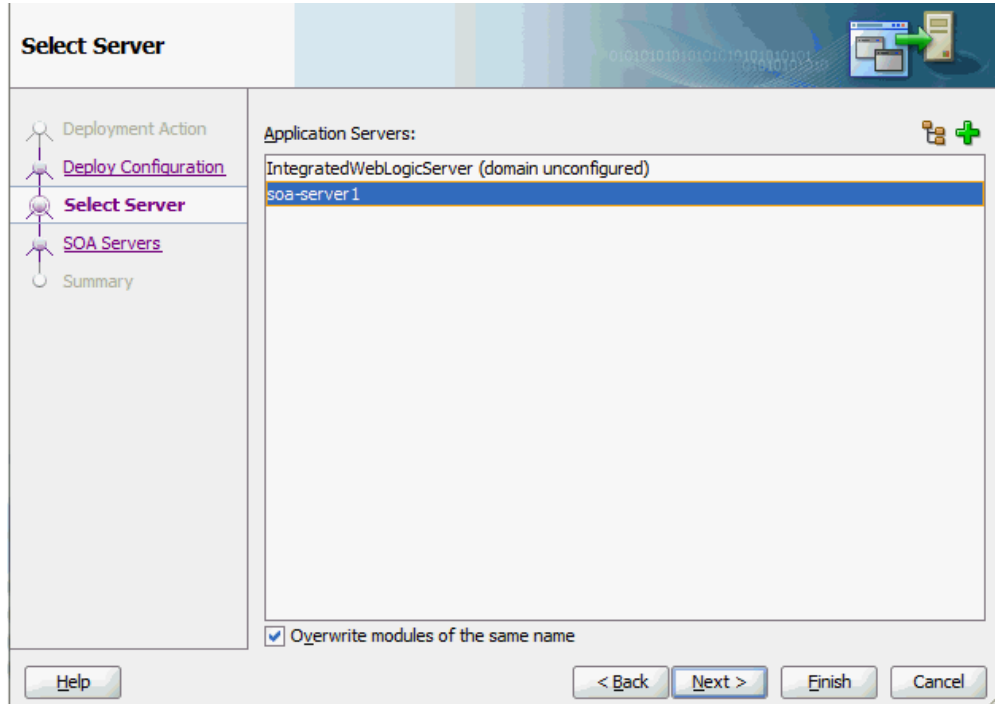

4. In the SOA Servers page, accept the default target SOA Server ('soa-server1') selection.

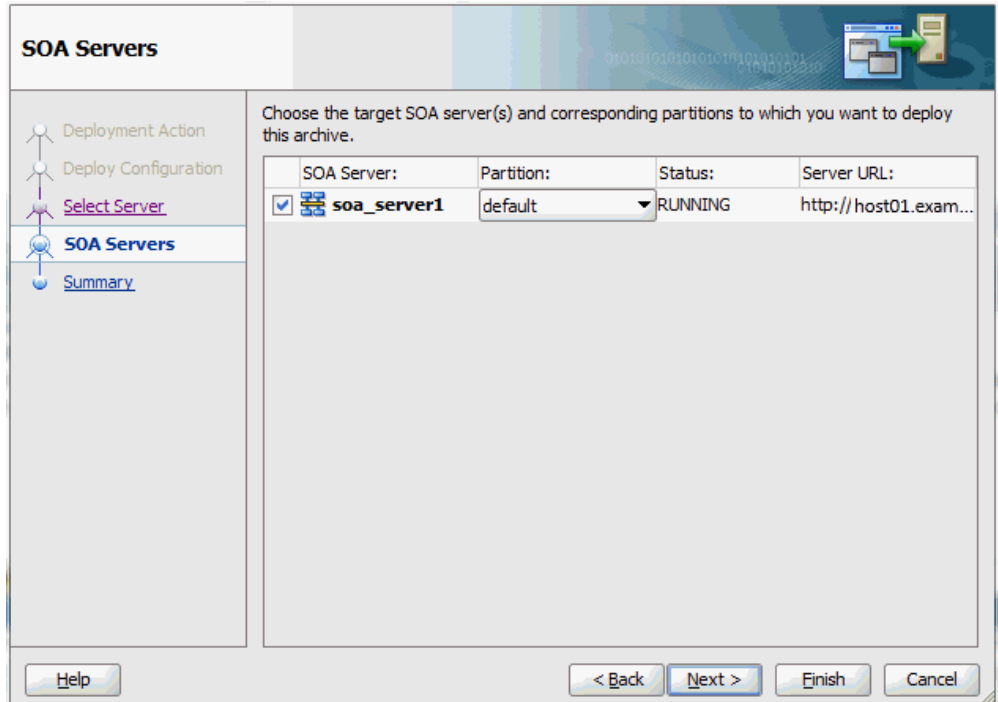

Click **Next** and **Finish**.

If you are deploying the composite for the first time from your Oracle JDeveloper session, the Authorization Request window appears. Enter username and password information specified during Oracle SOA Suite installation. Click **OK**.

5. Deployment processing starts. Monitor deployment progress and check for successful compilation in the SOA - Log window.

Verify that the deployment is successful in the Deployment - Log window.

## Testing the SOA Composite with BPEL Process

Once the BPEL process contained in the SOA Composite application is deployed, you can manage and monitor the process from the Oracle Enterprise Manager Fusion Middleware Control Console. You can also test the process and the integration interface by manually initiating the process.

### To test the deployed SOA Composite with BPEL process:

1. Navigate to Oracle Enterprise Manager Fusion Middleware Control Console (<http://<servername>:<portnumber>/em>). The composite you deployed is displayed in the Applications Navigation tree.

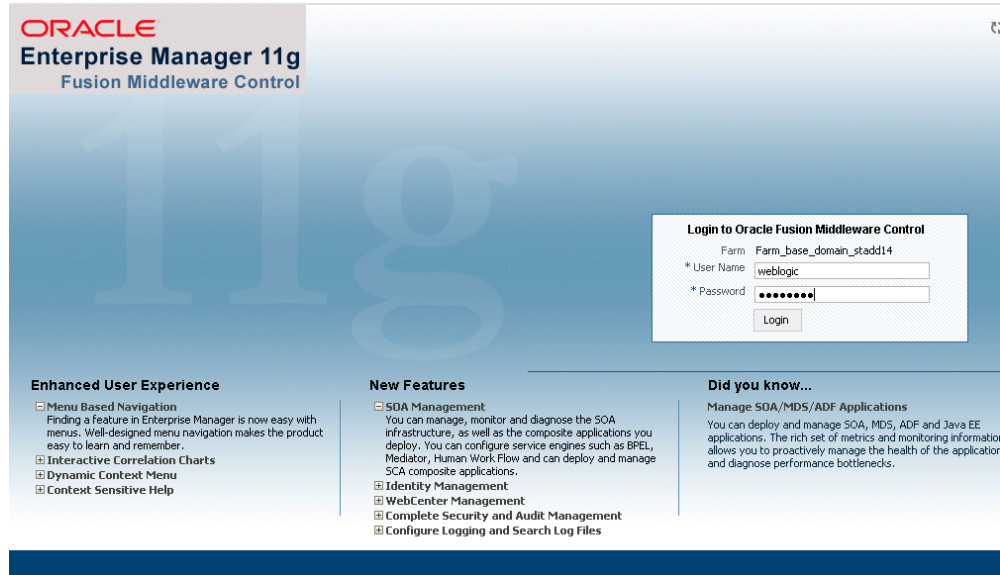

2. Enter username (such as `weblogic`) and password and click **Login** to log in to a farm.

You may need to select an appropriate target instance farm if there are multiple target Oracle Enterprise Manager Fusion Middleware Control Console farms.

3. From the Farm base domain, expand the **SOA >soa-infra** to navigate through the SOA Infrastructure home page and menu to access your deployed SOA composite applications running in the SOA Infrastructure for that managed server.

**Note:** The Farm menu always displays at the top of the navigator. As you expand the SOA folder in the navigator and click the links displayed beneath it, the SOA Infrastructure menu becomes available at the top of the page.

Click the SOA Composite application that you want to initiate (such as 'POInboundXMLGateway') from the SOA Infrastructure.

Click **Test** at the top of the page.

4. The Test Web Service page for initiating an instance appears. You can specify the XML payload data to use in the Input Arguments section.

Enter the input string required by the process and click **Test Web Service** to initiate the process.

### Testing Web Service

Name	Type	Value
* payload	payload	
* input	string	test

The test results appear in the Response tab upon completion.

5. Click the Instances tab. The SOA Composite application instance ID, name, conversation ID, most recent known state of each instance since the last data refresh of the page are displayed.

In the Instance ID column, click a specific instance ID to show the message flow through the various service components and binding components. The Flow Trace page is displayed.

In the Trace section, you should find the sequence of the message flow for the service binding component (`poinboundxmlgateway_client_ep`), BPEL component (`POInboundXMLGateway`), and reference binding components (`getOrderXML` and `XMLGatewayOrderInbound`). All involved components have successfully received and processed messages.

If any error occurred during the test, you should find it in the Faults section.

6. Click your BPEL service component instance link (such as `POInboundXMLGateway`) to display the Instances page where you can view execution details for the BPEL activities in the Audit Trail tab.

Click the Flow tab to check the BPEL process flow diagram. Click an activity of the process diagram to view the activity details and flow of the payload through the process.

## Verifying Records in Oracle E-Business Suite

Once the BPEL process contained in the SOA Composite application is successfully

initiated and completed, you can validate it through the relevant module in Oracle E-Business Suite applications.

For example, you can validate it using Oracle Transaction Monitor to ensure the process is successfully completed, and then import the order to Order Management application. You can then verify it in Oracle Order Management to ensure the order does exist.

### **To validate it Using Oracle Transaction Monitor**

Additionally, you can also validate it from the Transaction Monitor. The Transaction Monitor is a tool for monitoring the status of inbound and outbound transactions originating from and going into Oracle E-Business Suite applications that have been processed by the XML Gateway and delivered or received by the Oracle Transport Agent. It shows a complete history and audit trail of these documents.

You can navigate to the Transaction Monitor page using the Workflow Administrator Web responsibility. The Transaction Monitor provides the following:

- Flexible search criteria to support access to a specific document or group of documents
- Search results at the document header level with drill down by document ID
- Resend capability for outbound messages
- Viewing capability of the XML message content

**Note:** For details on using the Transaction Monitor, see *Oracle XML Gateway User's Guide*. This guide is part of the Oracle E-Business Suite Documentation Library which can be accessed on the Oracle Technology Network (OTN).

Use the following steps to validate in Oracle Transaction Monitor:

1. Log on to Oracle E-Business Suite with the Workflow Administrator Web Applications responsibility. Select Transaction Monitor to open the search window to search for the order.
2. Select the **Inbound Messages** radio button.

## Searching from the Transaction Monitor

ORACLE Transaction Monitor

Transaction Monitor:Search

**Search Criteria**

Select search criteria and press Go to view the report.

Inbound Messages  
Processing Status: All

Outbound Messages  
Generation Status: All  
Delivery Status: All  
Retry Status: All

Transaction Type:  Transaction Subtype:

Source TP Location Code:  Trading Partner Name:

Document ID: order\_xml\_01 Site Name:

Party Type: Customer

From Date:

To Date:

Enter the following information in the search window:

- Party Type: Customer
  - Document ID: Enter the document ID you defined for the header message property. For example, enter `order_xml_01`.
3. Click **Go** to retrieve all XML inbound messages listed in the Inbound Search Results region.

Confirm that transaction for 'order\_xml\_01' has the 'Success' status.

### To import the order to Oracle Order Management:

1. Log on to the Forms-based Oracle E-Business Suite with the Order Management Super User, Vision Operations (USA) responsibility.
2. Select Orders, Returns : Import Orders > Order Import Request. The Order Import Request window is displayed along with the Parameters dialog.

### Order Import Request

The screenshot shows two overlapping windows. The background window is titled "Order Import Request" and contains the following fields and options:

- Run this Request... (with a Copy... button)
- Name: Order Import
- Operating Unit: (empty)
- Parameters: (empty)
- Language: American English
- At these Times...: Run the Job As Soon as Possible
- Upon Completion...:  Save all Output
- Layout: (empty)
- Notify: (empty)
- Print to: noprint
- Buttons: Help (C)

The foreground window is titled "Parameters" and contains the following fields and options:

- Operating Unit: (empty)
- Order Source: (empty)
- Order Reference: (empty)
- Validate Only?: No
- Instances: 4
- Change Sequence: (empty)
- Trim Trailing Blanks: No
- Validate Descriptive Flexfield: Yes
- Buttons: OK, Cancel, Clear, Help

3. Click **OK** in the parameters dialog. The Order Import request name is populated automatically in the Import Request window.
4. Click **Submit** to submit the request. This displays a concurrent request number. Record the request number, but click **No** in the Decision dialog that you will not submit another request.
5. From the application menu, select View >Requests to open the Find Requests window.
6. Enter the request number you recorded earlier and click **Find**.

This would show the status of Order Import request. It should be success and the order should be created in Order Management application.

#### To validate it in Oracle Order Management:

1. Log on to the Forms-based Oracle E-Business Suite with the Order Management, Super User responsibility.
2. Select Order Returns > Sales Order. Sales Order Forms would open up.
3. Search for an order by entering the order number (order\_xml\_01) in the Customer PO field. This would bring up the details of a newly created order using XML Gateway inbound map.



## Sales Orders

Order Information		Line Items
Default		
Main Others		
Customer	Business World	Order Number: 64693
Customer Number	1608	Order Type: Mixed
Customer PO	order_xml_01	Date Ordered: 16-MAR-2009 23:39:11
Customer Contact		Price List: Corporate
Operating Unit	Vision Operations	Salesperson: Sprague, Mr. Howard
Ship To Location	San Jose (OPS)	Status: Entered
	2391 L Street	Currency: USD
	San Jose, CA, 95106, US	Subtotal: 2,399.00
Bill To Location	San Jose (OPS)	Tax: 215.91
	2391 L Street	Charges: 71.97
		Total: 2,686.88
	San Jose, CA, 95106, US	

You can also select the Items tab for item details.

## Design-Time Task for XML Gateway Outbound Messaging

For an outbound XML Gateway Map interface, since an outbound message is first enqueued to the ECX\_OUTBOUND queue, Oracle BPEL PM listens to ECX\_OUTBOUND queue for the message with the same correlation Id. The message will then be dequeued to retrieve outbound data from Oracle E-Business Suite. The retrieved data can be passed to trading partners or consumers who subscribed to the message.

### SOA Composite Application with BPEL Process Scenario

Take XML Gateway outbound interface PO acknowledgement XML Transaction as an example. The XML Gateway outbound interface is exposed as a Web service through ECX\_CBODO\_OAG72\_OUT\_CONFIRM outbound map.

When a purchase order is created and approved, on approval of the purchase order, a workflow will be triggered which creates the Purchase Order Acknowledgement flow and sends out the PO Acknowledgement as an XML file. The workflow delivers the Confirm BOD as the PO Acknowledgement to ECX\_OUTBOUND queue for delivery to the other system.

The correlation Id for this message is set to "BPEL" and the Oracle BPEL PM listens to ECX\_OUTBOUND queue for the message with the correlation Id "BPEL". Confirm BOD as the PO Acknowledgement is written as an output XML file using File Adapter.

## Prerequisites to Configure XML Gateway Outbound

### Setting Up Correlation Identifier

For invoking an outbound message map, you need to set up the correlation identifier in Oracle Applications. The correlation identifier enables you to label messages meant for a specific agent, in case there are multiple agents listening on the outbound queue. The agent listening for a particular correlation picks up the messages that match the correlation identifier for the agent.

To set up the correlation identifier:

1. Log in to Oracle Applications with the XML Gateway responsibility. The Navigator page appears.
2. Click the **XML Gateway** link.
3. Click the **Define Lookup Values** link under XML Gateway to open the XML Gateway Lookups form.

### XML Gateway Lookups

Code	Meaning	Description	Tag	From	To	Enabled
HTTPS-OXTA	Attachment Enabled C	Attachment Enabled OX		25-OCT-2002	12-DEC-2002	<input type="checkbox"/>
HTTPS-WM	WebMethods using HT	HTTPS with WebMethod		28-SEP-2000		<input checked="" type="checkbox"/>
BPEL	BPEL	Used for Apps Adapter I		09-MAR-2009		<input checked="" type="checkbox"/>
IAS	Oracle Integration Ser	Oracle Integration Serve		07-FEB-2002		<input type="checkbox"/>
ITG03	Oracle iProcurement C	Oracle iProcurement Co		07-FEB-2002		<input type="checkbox"/>
JMS	JMS	JMS		08-JUL-2002		<input checked="" type="checkbox"/>
NONE	No Electronic Delivery	No Electronic Delivery		28-SEP-2000		<input checked="" type="checkbox"/>
OTAH-ATCH	Attachment Enabled C	Attachment Enabled Or		12-DEC-2002		<input checked="" type="checkbox"/>
OTAHS-ATCH	Attachment Enable Or	Attachment Enable Orac		12-DEC-2002		<input checked="" type="checkbox"/>
SMTP	Email (SMTP)	Email Delivery		28-SEP-2000		<input checked="" type="checkbox"/>

4. Search for `COMM_METHOD` in the **Type** field to see if it exists in the system.
5. Add a new record to the `COMM_METHOD` type by entering `BPEL` for the **Code** field and **Meaning** field. Enter description information and save the record.

Oracle XML Gateway puts the correlation of BPEL when enqueueing the message

on the ECX\_OUTBOUND queue.

### *Setting Up XML Gateway Trading Partner*

Once you have the correlation identifier set up correctly, you also need to ensure a valid outbound XML Gateway trading partner in the Trading Partner Setup form through XML Gateway responsibility. You want to have the Protocol Type field set to BPEL.

For example, a Trading Partner (such as 'Business World' with Site information '2391 L Street San Jose CA 95106' and partner type 'Customer') has the following details for an outbound transaction:

- Transaction type: ECX
- Transaction sub type: CBODO
- Standard Code: OAG
- External transaction type: BOD
- External transaction subtype: CONFIRM
- Direction: OUT
- Map: ECX\_CBODO\_OAG72\_OUT\_CONFIRM
- Connection/Hub: DIRECT
- Protocol Type: BPEL
- Source Trading partner location code: BWSANJOSE

## Trading Partner Setup

The screenshot shows the 'Trading Partner Setup' window. At the top, there are several input fields: 'Operating Unit' (Vision Project Manufact), 'Trading Partner Type' (Customer), 'Trading Partner Name' (Business World), 'Trading Partner Site' (2391 L Street San Jose CA 95106), and 'Company Admin Email' (oraclebworld@yahoo.com). Below these fields are two buttons: 'User Setup' and 'Code Conversion'. The main section is titled 'Trading Partner Details' and contains a table with the following columns: Transaction Type, Transaction SubType, Standard Code, External Transaction Type, External Transaction SubType, Direction Map, Connection/Hub, and Protocol Type.

Transaction Type	Transaction SubType	Standard Code	External Transaction Type	External Transaction SubType	Direction Map	Connection/Hub	Protocol Type
AR	CONFIRM_E	OAG	BOD	CONFIRM	IN	002_confirm_t	
ECX	CBODO	OAG	BOD	CONFIRM	IN	ECX_CBODI_C	
ECX	CBODO	OAG	BOD	CONFIRM	OUT	CONFIRM...	DIRECT HTTP
AR	PROCESS_	OAG	INVOICE	PROCESS	OUT	171_process_	DIRECT HTTP
OZF	POSI	OAG	POS	PROCESS	IN	OZF_PROCES	
OZF	POSI	OAG	POS	PROCESS	IN	OZF_PROCES	
OZF	POSO	OAG	POS	PROCESS	OUT	OZF_PROCES	DIRECT HTTP

## SOA Composite Application with BPEL Process Creation Flow

Based on the PO acknowledgement XML Transaction scenario, the following design-time tasks are discussed in this chapter:

1. Create a new SOA Composite application with BPEL process, page 5-50
2. Create a Partner Link, page 5-54
3. Add a Receive activity, page 5-59
4. Add a Partner Link for File Adapter, page 5-61
5. Add an Invoke activity, page 5-65
6. Add an Assign activity, page 5-67

## Creating a SOA Composite Application with BPEL Process

To create a SOA Composite application with BPEL process:

1. Launch Oracle JDeveloper.

2. Click **New Application** in the Application Navigator.

The Create SOA Application - Name your application page is displayed.

### The Create SOA Application - Name your application Page

**Create SOA Application - Step 1 of 3**

### Name your application

**Application Name**  
XMLGatewayOutbound -App

**Project Name**

Project SOA Settings

**Application Name:**  
XMLGatewayOutbound -App

**Directory:**  
C:\JDeveloper\mywork\ XMLGatewayOutbound -App **Browse...**

**Application Package Prefix:**

**Application Template:**

- Java Desktop Application (ADF)**  
Creates a databound rich client application. The application consists of one project for the client (ADF Swing), and another project for the ADF Model (ADF Business Components).
- Java EE Web Application**  
Creates a databound web application. The application consists of one project for the view and controller components (JSF), and another project for the data model (EJB session beans and JPA entities).
- SOA Application**  
Creates a SOA (service-oriented architecture) application. The application consists of one SOA project for the SOA composite, components, and adapters.

**Help** **< Back** **Next >** **Finish** **Cancel**

3. Enter an appropriate name for the application in the **Application Name** field and select **SOA Application** from the Application Template list.

Click **Next**. The Create SOA Application - Name your project page is displayed.

4. Enter an appropriate name for the project in the **Project Name** field. For example, XMLGatewayOutbound.

### The Create SOA Application - Name your project Page

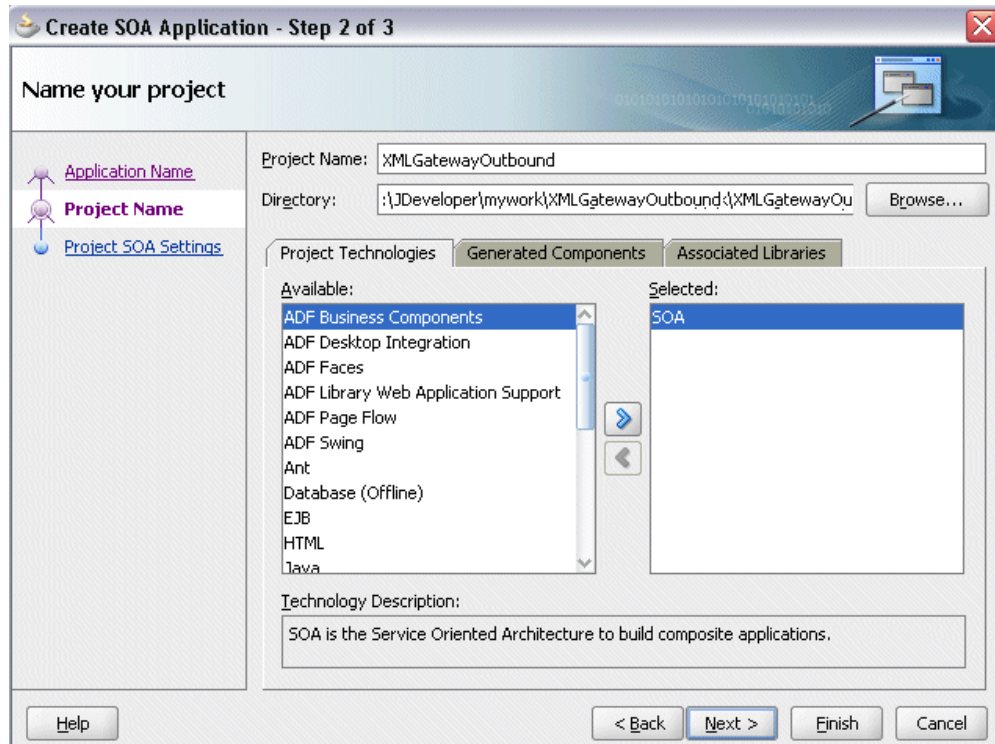

5. In the Project Technologies tab, ensure that **SOA** is selected from the Available technology list to the Selected technology list.

Click **Next**. The Create SOA Application - Configure SOA settings page is displayed.

6. Select **Composite With BPEL** from the Composite Template list, and then click **Finish**. You have created a new application, and a SOA project. This automatically creates a SOA Composite.

The Create BPEL Process page is displayed.

7. Leave the default **BPEL 1.1 Specification** selection unchanged. This creates a BPEL project that supports the BPEL 1.1 specification.

Enter an appropriate name for the BPEL process in the **Name** field. For example, XMLGatewayOutbound.

Select **Define Service Later** in the **Template** field. Click **OK**.

### Create BPEL Process

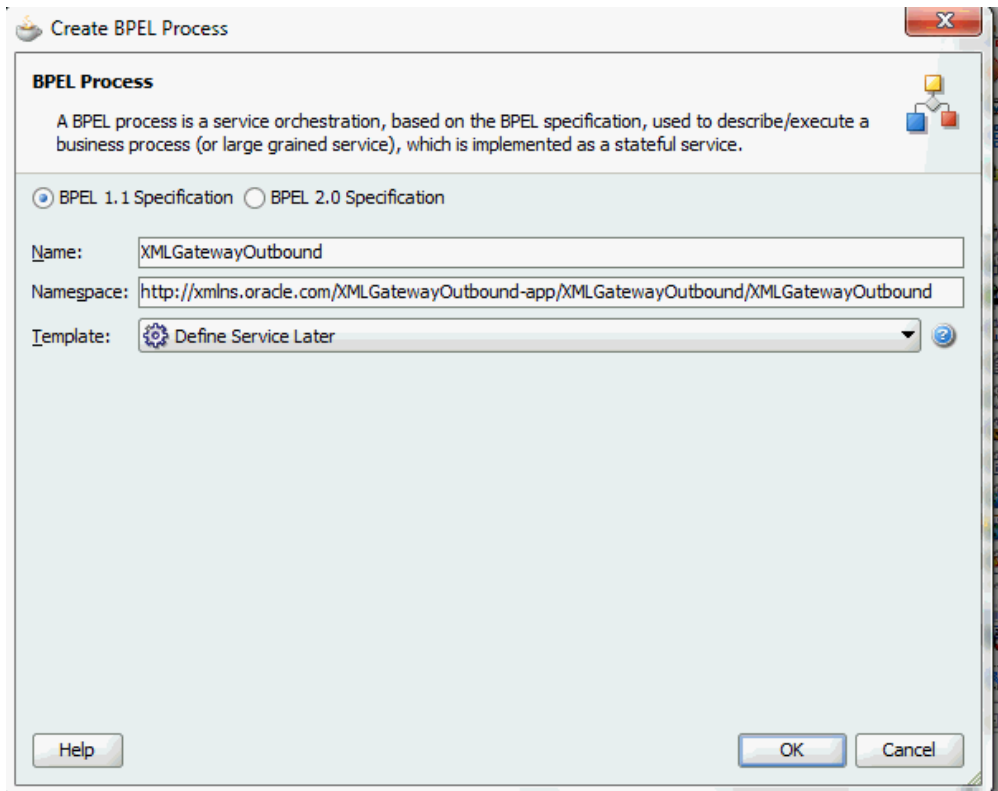

An empty BPEL process is created. The required source files including bpel and wsdl, using the name you specified (for example, XMLGatewayOutbound.bpel and XMLGatewayOutbound.wsdl) and composite.xml are also generated.

### An Empty BPEL Process

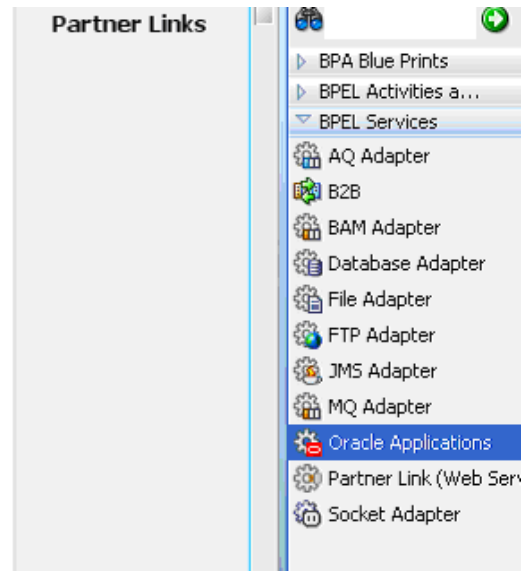
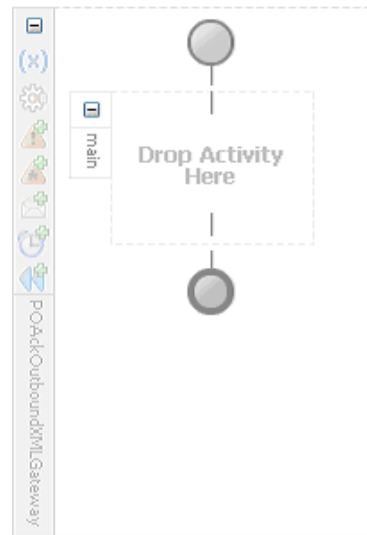

## Adding a Partner Link

This section describes how to create an Oracle Applications adapter for the application service by adding a partner link to your BPEL process. A BPEL partner link defines the link name, type, and the role of the BPEL process that interacts with the partner service.

You need to add a partner link for the outbound XML message in order for the Receive activity to dequeue it later.

### To add a partner link:

1. Click **BPEL Services** in the Component palette.

Drag and drop **Oracle Applications** from the BPEL Services list into the right Partner Link swim lane of the process diagram. The Adapter Configuration Wizard Welcome page appears. Click **Next**.

2. Enter a service name in the **Service Name** field. For example, XMLGatewayPOAckOutbound.

Click **Next**. The Service Connection dialog appears.

3. You can perform either one of the following options for your database connection:

**Note:** You need to connect to the database where Oracle Applications is running.



- You can create a new database connection by clicking the **Create a New Database Connection** icon.

How to define a new database connection, see *Create a New Database Connection*, page 5-13.

- You can select an existing database connection that you have configured earlier from the **Connection** drop-down list.

The Service Connection page will be displayed with the selected connection information. The JNDI (Java Naming and Directory Interface) name corresponding to the database connection appears automatically in the **Database Server JNDI Name** field. Alternatively, you can specify a JNDI name.

**Note:** When you specify a JNDI name, the deployment descriptor of the Oracle Applications adapter must associate this JNDI name with configuration properties required by the adapter to access the database.

The JNDI name acts as a placeholder for the connection used when your service is deployed to the BPEL server. This enables you to use different databases for development and later for production.

**Note:** For more information about JNDI concepts, refer to *Oracle Fusion Middleware User's Guide for Technology Adapters*.

4. Once you have completed creating a new connection for the service, you can add an outbound message map by browsing through the list of APIs available in Oracle Applications.

Click **Next**.

#### **For Oracle E-Business Suite Release 12:**

If you are connecting to Oracle E-Business Suite Release 12, then the **IREP File not present** dialog appears indicating that Adapter could not find the Oracle Integration Repository data file corresponding to the database you are connecting in your workspace. Absence of the data file would make browsing or searching of Integration Repository tree considerably slow. You can choose to extract the data file and create a local copy of the Integration Repository data file. Once it is created successfully, Adapter will pick it up automatically next time and retrieve data from your local Integration Repository.

You can select one of the following options:

- Click **Yes** to extract the Integration Repository data file.

### Extracting Integration Repository Data File

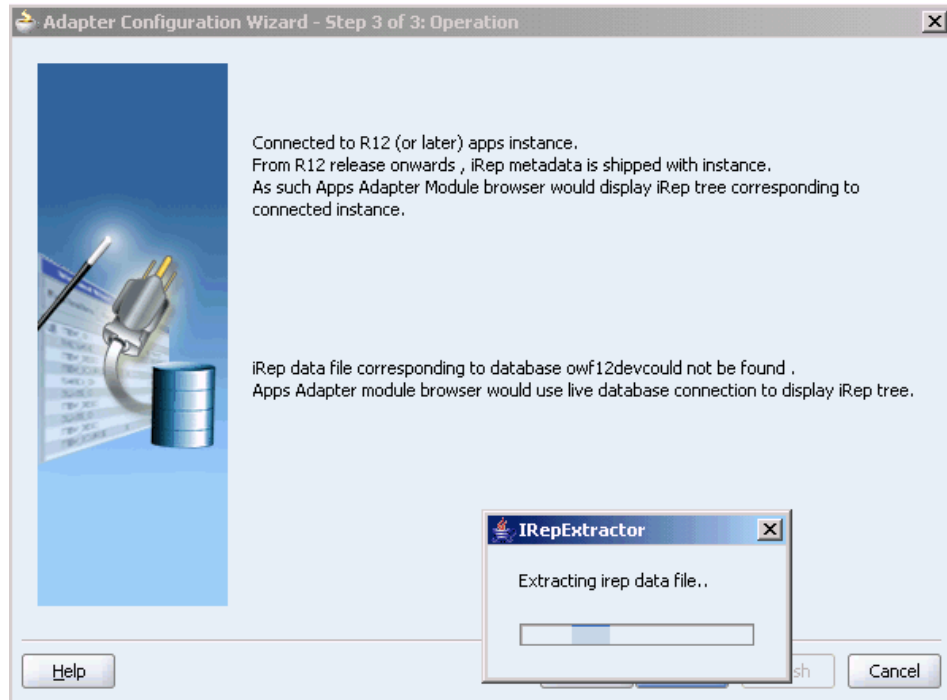

After the system successfully creates a local copy of the Integration Repository data file, next time when you connect to the database, you will find the **IRep Data File** field appears in the Operation dialog indicating where your local copy exists with the creation date and time as part of the file name.

### Using the Local Integration Repository Data File

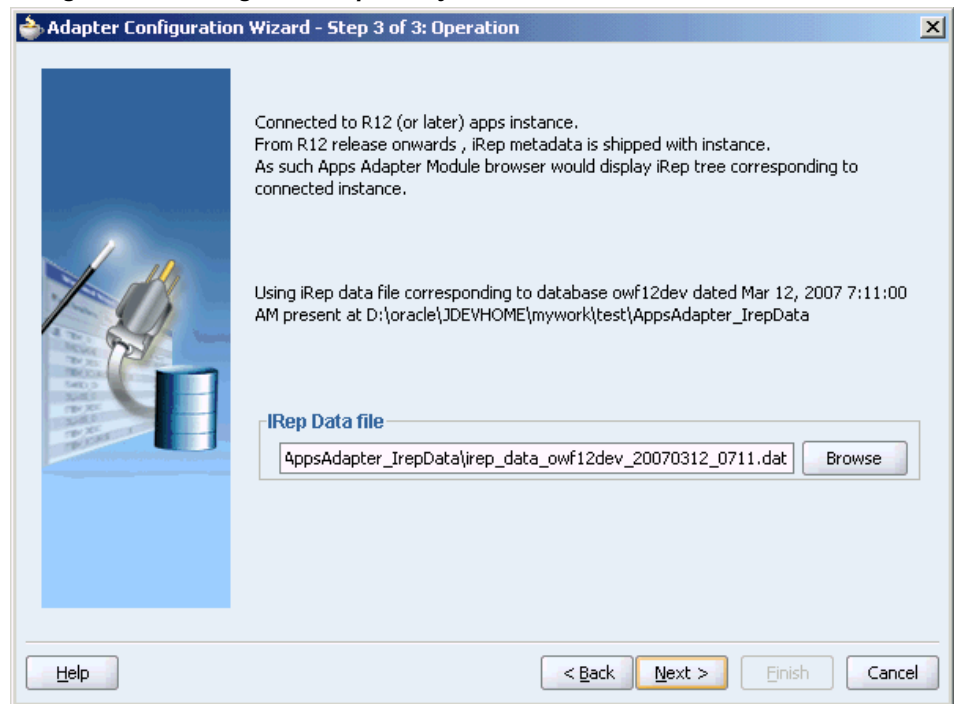

- Click **No** to query the Integration Repository data file from the live database you are connecting to display the Integration Repository tree.

Click **Next** in the Operation page to open the Oracle Applications Module Browser.

#### **For Oracle E-Business Suite Release 11.5.9:**

If you are connecting to an Oracle E-Business Suite Release 11.5.9 instance, you must select the interface type in the Adapter Configuration Wizard. Select **XML Gateway** to proceed.

Click **Get Object** in the Application Interface dialog to open the Oracle Applications Module Browser.

5. The Oracle Applications Module Browser combines interface data from Oracle Integration Repository with information about the additional interfaces supported by Oracle Application Adapter, organized in a tree hierarchy.

## Specify an API from The Oracle Applications Module Browser

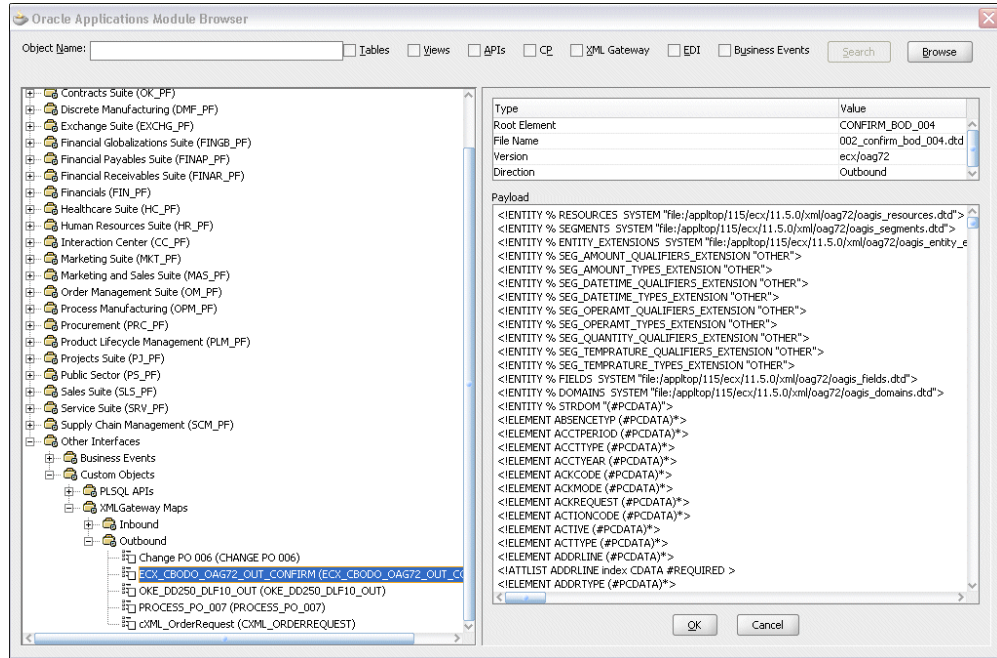

**Note:** The Oracle Applications Module Browser includes the various product families that are available in Oracle Applications. Each product family contains the individual products. Each product contains the business entities associated with the product. Business entities contain the various application modules that are exposed for integration. These modules are grouped according to the interface they provide.

Navigate to *Other Interfaces > Custom Objects > XML Gateway Maps > Outbound* to select an outbound map `ECX_CBODO_OAG72_OUT_CONFIRM`.

6. Click **OK**.

### Adapter Configuration Wizard - Application Interface Page

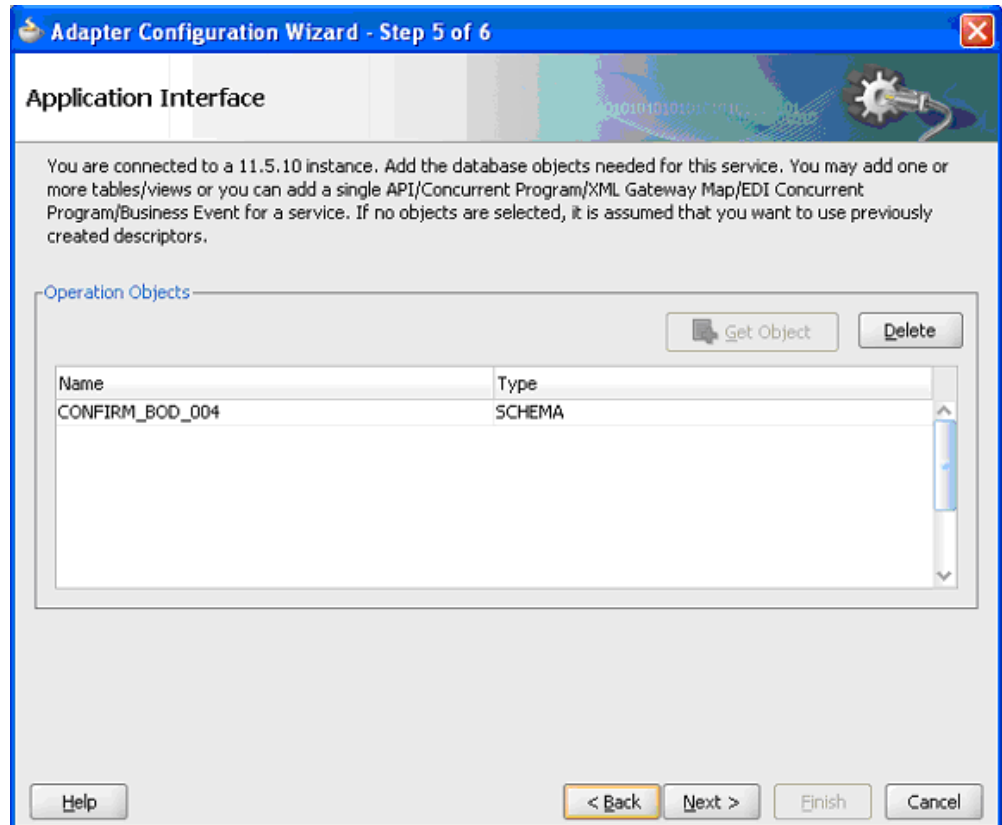

7. Click **Next**, then click **Finish** to complete the process of configuring Adapter for Oracle Applications.

The wizard generates the WSDL file corresponding to the XML schema. This WSDL file is now available for the partner link.

8. Click **Apply** and then **OK**. The partner link is created with the required WSDL settings.

## Adding a Receive Activity

When configuring the Adapter for Oracle Applications to use an outbound XML Gateway map, you need to configure the Receive activity for the associated partner link. The Receive activity dequeues the outbound XML messages.

### To configure the Receive activity:

1. In Oracle JDeveloper BPEL Designer, expand the **BPEL Constructs** from the Component Palette. Drag and drop **Receive** from the BPEL activity list into the

center swim lane of the process diagram.

2. Link the **Receive** activity to the partner link XMLGatewayPOAckOutbound you created earlier.

The Receive dialog appears.

#### Configuring the Receive Activity

The screenshot shows the 'Receive' dialog box with the following configuration:

- Name:** Receive
- Conversation ID:** (empty)
- Create Instance**
- Interaction Type:** Partner Link
- My Role Web Service Interface:**
  - Partner Link:** XMLGatewayPOAckOutbound
  - Operation:** Dequeue
- Variable:** (empty)

3. Enter an appropriate name for the Receive activity.

The Dequeue **Operation** is automatically selected since the partner link has been configured with an outbound XML Gateway map.

4. Specify a **Variable** to receive the message data from the partner link by clicking the **Create** icon to the right of the Variable field.

The **Create Variable** dialog box appears.

Click **OK** to accept the default name.

5. Select the **Create Instance** check box.

### Configuring the Receive Activity

The screenshot shows the 'Receive' dialog box with the following configuration:

- Name:** Receive
- Conversation ID:** (empty)
- Create Instance**
- Interaction Type:** Partner Link
- My Role Web Service Interface:**
  - Partner Link:** XMLGatewayPOAckOutbound
  - Operation:** Dequeue
- Variable:** Receive\_Dequeue\_InputVariable

6. Click **Apply** in the Receive dialog, then click **OK**.

## Adding a Partner Link for File Adapter

Use this step to write PO acknowledgement details in an XML file as an output file.

### To add a Partner Link for File Adapter:

1. In Oracle JDeveloper BPEL Designer, click **BPEL Services** in the Component palette. Drag and drop **File Adapter** from the BPEL Services list into the right Partner Link swim lane of the process diagram. The Adapter Configuration Wizard Welcome page appears.

Click **Next**.

2. In the Service Name dialog, enter a name for the file adapter service, for example, WriteAck.
3. Click **Next**. The Adapter Interface page appears.

### Specifying the Adapter Interface

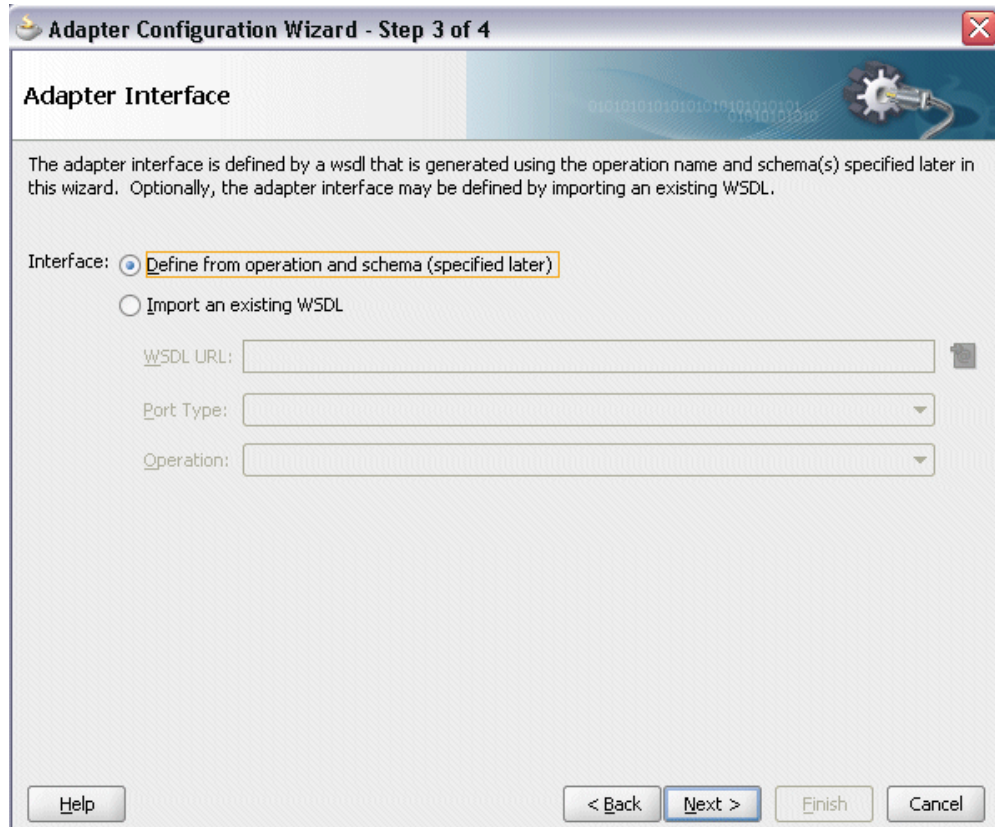

The screenshot shows a window titled "Adapter Configuration Wizard - Step 3 of 4". The main heading is "Adapter Interface". Below the heading, there is a descriptive text: "The adapter interface is defined by a wsdl that is generated using the operation name and schema(s) specified later in this wizard. Optionally, the adapter interface may be defined by importing an existing WSDL." Under the heading "Interface:", there are two radio buttons: "Define from operation and schema (specified later)" (which is selected) and "Import an existing WSDL". Below these are three input fields: "WSDL URL:" (with a file icon), "Port Type:" (a dropdown menu), and "Operation:" (a dropdown menu). At the bottom of the window, there are four buttons: "Help", "< Back", "Next >" (highlighted in blue), "Finish", and "Cancel".

Select the **Define from operation and schema (specified later)** radio button and click **Next**.

4. In the Operation page, specify the operation type. For example, select the **Write File** radio button. This automatically populates the **Operation Name** field.



### Specifying the Operation

**Operation**

The File Adapter supports four operations. There is a Read File operation that polls for incoming files in your local file system, a Write File operation that creates outgoing files, a Synchronous Read File operation that reads the current contents of a file, and a List Files operation that lists file names in specified locations. Specify the Operation type and Operation Name. Only one operation per Adapter Service may be defined using this wizard.

Operation Type:  Read File  
 Write File  
 Synchronous Read File  
 List Files

Operation Name:

Help < Back Next > Finish Cancel

Click **Next** to access the File Configuration page.

## Adapter Configuration Wizard - File Configuration Page

Specify the parameters for the Write File operation.

Directory specified as  Physical Path  Logical Name

Directory for Outgoing Files (logical name):  
outputDir

File Naming Convention (po\_%SEQ%.txt): POAck%yyMMddJJmms% .xml

Append to existing file

Write to output file when any of these conditions are met:

Number of Messages Equals: 1

Elapsed Time Exceeds: 1 minutes

File Size Exceeds: 1000 kilobytes

Help < Back Next > Finish Cancel

5. For the Directory specified as field, select **Logical Name**. Enter directory name in the Directory for Outgoing Files (logical name) field, for example, `outputDir`.

Specify a naming convention for the output file, for example, `POAck%yyMMddJJmms% .xml`.

Select the **Number of Messages Equals** check box and set it to '1'.

Click **Next** to open the Messages page.

6. Select the 'browse for file schema' icon next to the URL field to locate the schema location and schema element.

The Type Chooser dialog box appears. Expand the node by clicking **Project Schema Files > CONFIRM\_BOD\_004.xsd**. Select **CONFIRM\_BOD\_004** and click **OK**.

The selected schema information will be automatically populated in the URL and Schema Element fields.

### Adapter Configuration Wizard - Messages Page

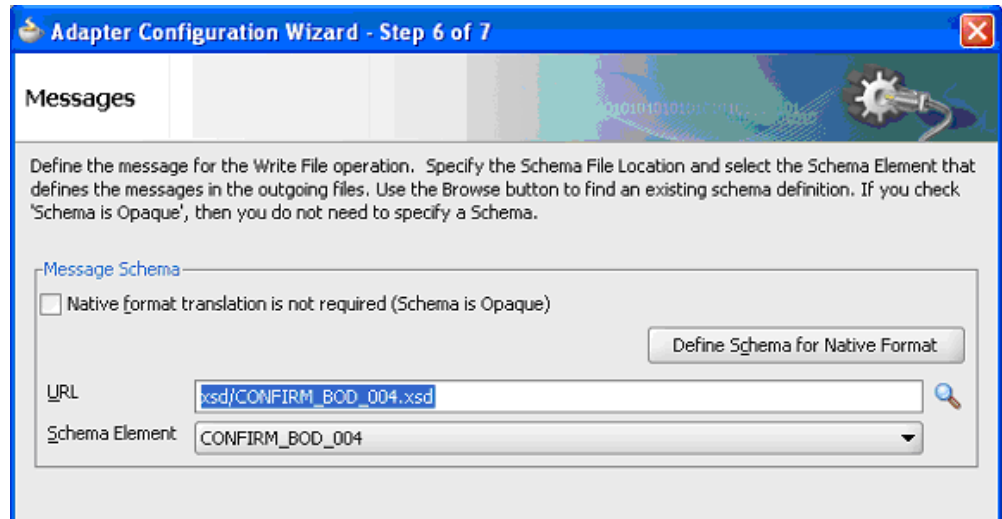

7. Click **Next** and then **Finish**. The wizard generates the WSDL file corresponding to the partner link. The main Create Partner Link dialog box appears, specifying the new WSDL file `WriteAck.wsdl`.

Click **Apply** and **OK** to complete the configuration and create the partner link with the required WSDL settings for the File Adapter service.

The `WriteAck` Partner Link appears in the BPEL process diagram.

## Adding an Invoke Activity

This step is to configure an Invoke activity to write PO acknowledgement information to an XML file through invoking the partner link for File Adapter.

### To add an Invoke activity:

1. In Oracle JDeveloper BPEL Designer, expand the **BPEL Constructs** from the Component Palette. Drag and drop the **Invoke** activity into the center swim lane of the process diagram after the **Receive** activity.
2. Link the Invoke activity to the `WriteAck` service.

### Adding an Invoke Activity

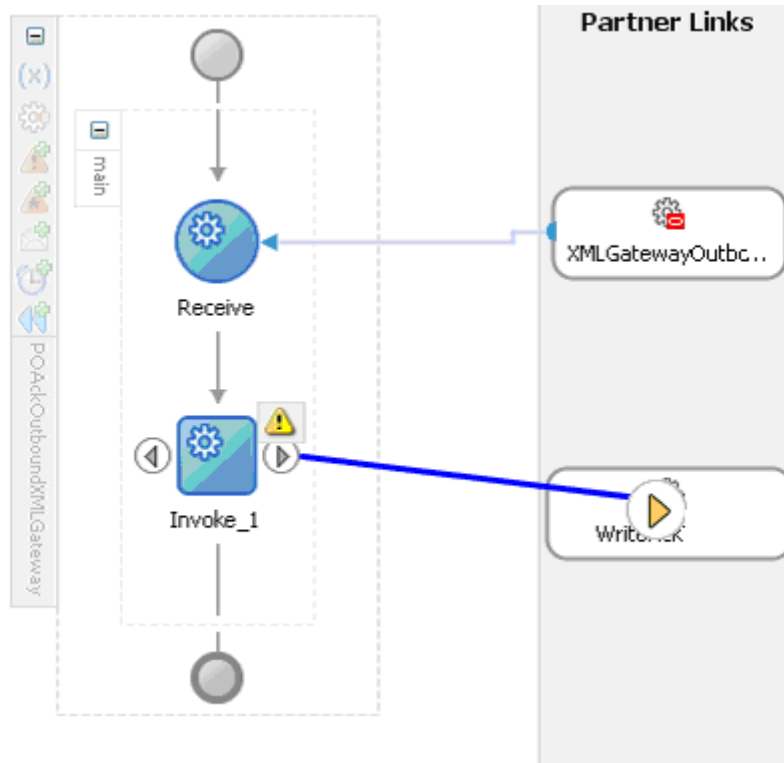

The Edit Invoke dialog appears.

3. Enter a name for the Invoke activity, then click the **Create** icon next to the **Input Variable** field to create a new variable. The Create Variable dialog box appears.
4. Select **Global Variable**, then enter a name for the variable. You can also accept the default name. Click **OK**.

Click **Apply** and then click **OK** in the Edit Invoke dialog to finish configuring the Invoke activity.

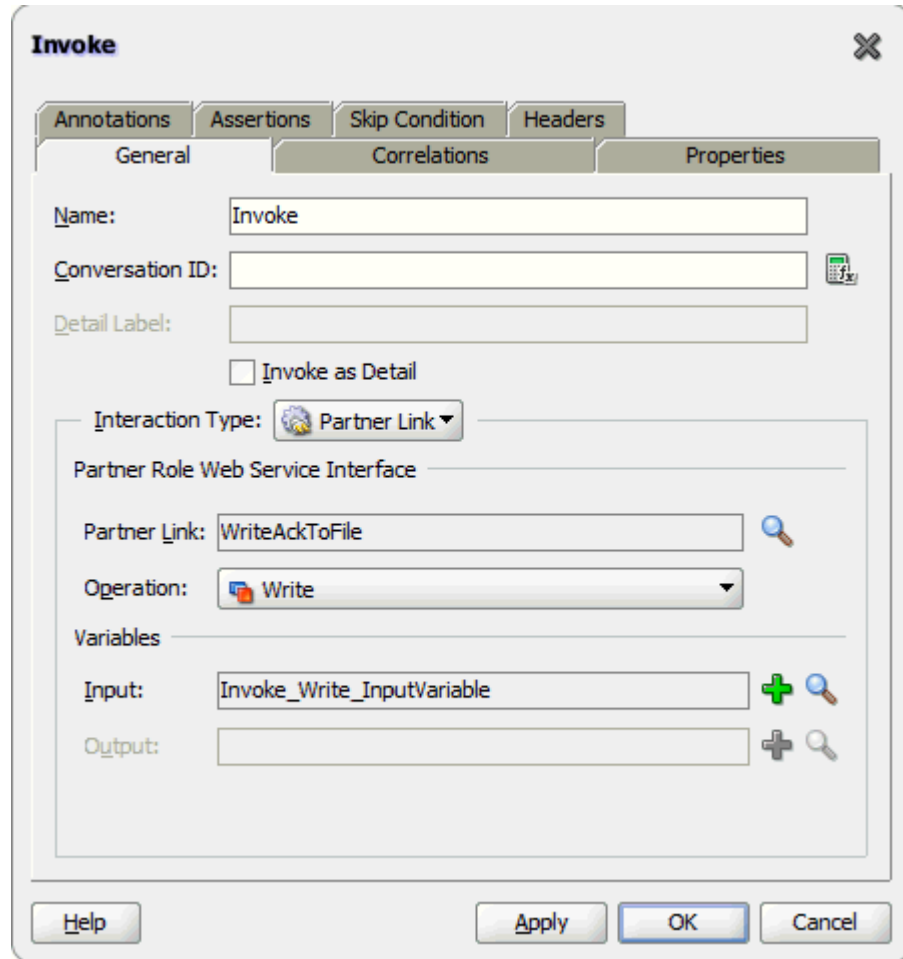

The Invoke activity appears in the process diagram.

## Adding an Assign Activity

Use the Assign activity to take the output from the Receive activity and to provide input to the Invoke activity.

### To add an Assign activity:

1. In Oracle JDeveloper BPEL Designer, expand the **BPEL Constructs** from the Component Palette. Drag and drop the **Assign** activity into the center swim lane of the process diagram, between the **Receive** and **Invoke** activities that you just created earlier.
2. Double-click the **Assign** activity to access the Edit Assign dialog. Click the General tab to enter a name for the Assign activity.
3. Select the Copy Rules tab and expand the target trees:

- In the From navigation tree, navigate to **Variable > Process > Variables > Receive\_DEQUEUE\_InputVariable** and select **CONFIRM\_BOD\_004**.
- In the To navigation tree, navigate to **Variable > Process > Variables > Invoke\_Write\_InputVariable** and select **body**.

Drag the source node (CONFIRM\_BOD\_004) to connect to the target node (body) that you just identified. This creates a line that connects the source and target nodes. The copy rule is displayed in the From and To sections at the bottom of the Edit Assign dialog box.

### Assigning Parameters

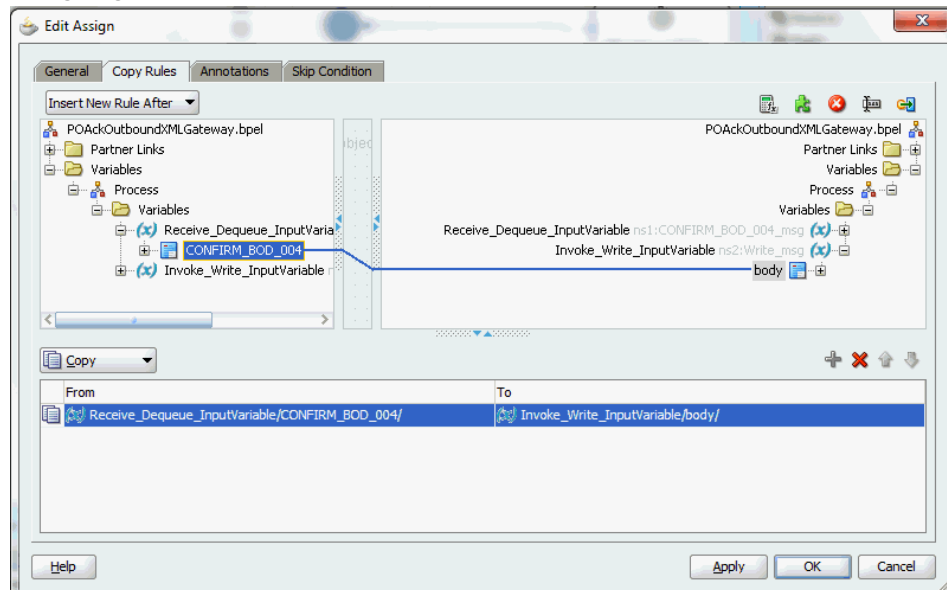

4. Click **Apply** and then click **OK** to complete the configuration of the Assign activity.

The following diagram illustrates the complete BPEL process diagram:

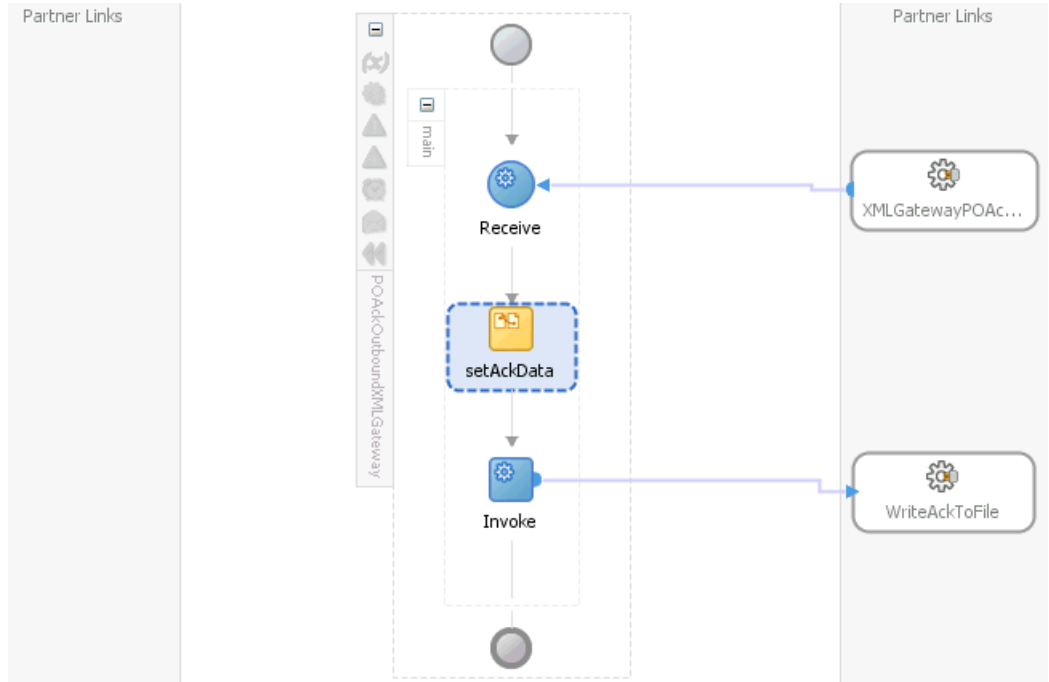

Click the composite.xml to display the Oracle JDeveloper composite diagram:

**Note:** Click the Source tab of composite.xml to enter a value for the physical directory outputDir for the reference WriteEventData (such as /usr/tmp).

```
<property name="outputDir" type="xs:string"
many="false" override="may">/usr/tmp</property>
```

**Oracle JDeveloper composite Diagram**

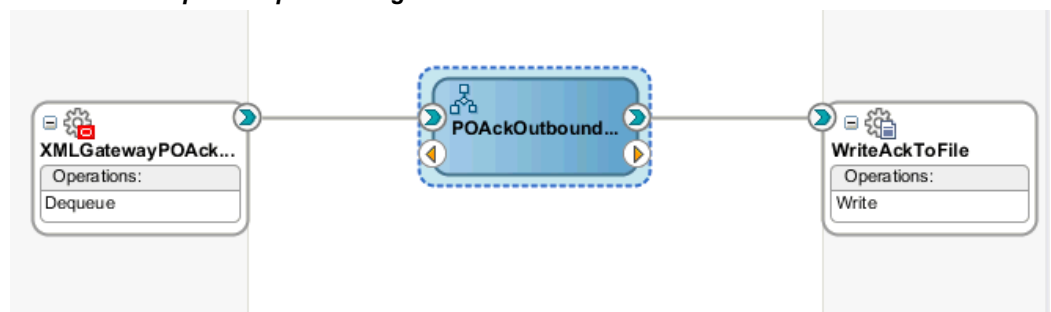

## Run-Time Task for XML Gateway Outbound Messaging

After designing the SOA Composite application with BPEL process, you can compile, deploy and test it.

1. Deploy the SOA Composite application with BPEL process, page 5-70
2. Test the SOA Composite with BPEL process, page 5-74

## Deploying the SOA Composite Application with BPEL Process

After creating a SOA composite application with BPEL process for XML Gateway outbound message map, you need to deploy it to the Oracle WebLogic managed server. This can be achieved using Oracle JDeveloper. Once the composite is deployed, it can be tested from the Oracle Enterprise Manager Fusion Middleware Control Console.

### Prerequisites

Before deploying the SOA composite with BPEL process using Oracle JDeveloper, you must have established the connectivity between the design-time environment and the run-time server. For more information, see *Configuring the Data Source in Oracle WebLogic Server*, page A-3 and *Creating an Application Server Connection*, page A-12.

**Note:** If a local instance of the WebLogic Server is used, start the WebLogic Server by selecting **Run > Start Server Instance** from Oracle JDeveloper. Once the WebLogic Admin Server "DefaultServer" instance is successfully started, the <Server started in Running mode> and DefaultServer started message in the Running:DefaultServer and Messages logs should appear.

```

Running: DefaultServer - Log
<Mar 30, 2009 3:53:04 PM PDT> <Notice> <WebLogicServer> <BEA-000331> <Started WebLogic Admin Serve
<Mar 30, 2009 3:53:04 PM PDT> <Notice> <WebLogicServer> <BEA-000365> <Server state changed to RUNN
<Mar 30, 2009 3:53:04 PM PDT> <Notice> <WebLogicServer> <BEA-000360> <Server started in RUNNING mo
DefaultServer startup time: 70828 ms.
DefaultServer started.
Messages BPEL Extensions Feedback Running: DefaultServer

```

### To deploy the SOA Composite application with BPEL process:

1. Select the SOA Composite project in the Applications Navigator.
2. Right-click the project name. Select **Deploy > [project name] > [serverConnection]** from the menu that appears.

For example, you can select **Deploy > XMLGatewayOutbound > soa-server1** to deploy the process if you have the connection set up appropriately.

**Note:** If this is the first time to set up server connection, then the Deployment Action window appears. Select 'Deploy to Application Server' and click **Next**.



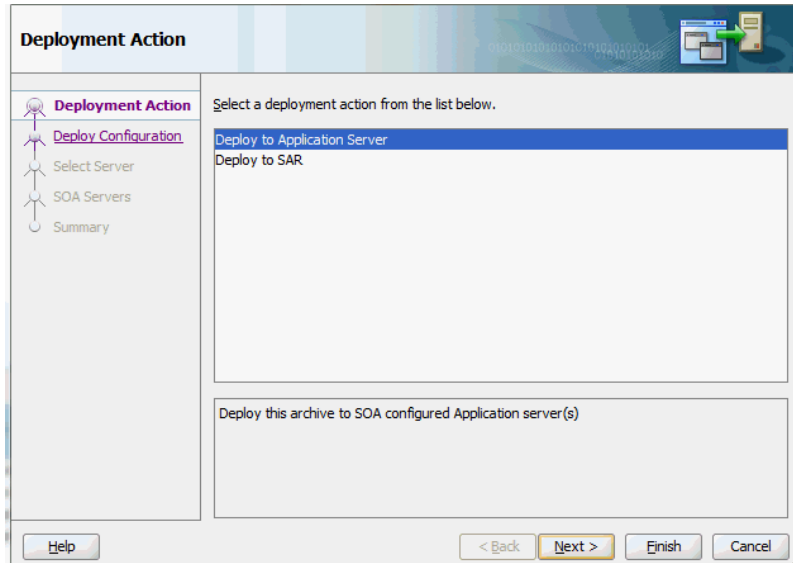

In the Deploy Configuration window, ensure the following information is selected before clicking **Next** to add a new application server:

- New Revision ID: 1.0
- Mark composite revision as default: Select this check box.
- Overwrite any existing composites with the same revision ID: Select this check box.

The steps to create a new Oracle WebLogic Server connection from JDeveloper are covered in [Creating an Application Server Connection](#), page A-12.

3. In the Select Server page, select 'soa-server1' that you have established the server connection earlier. Click **Next**.

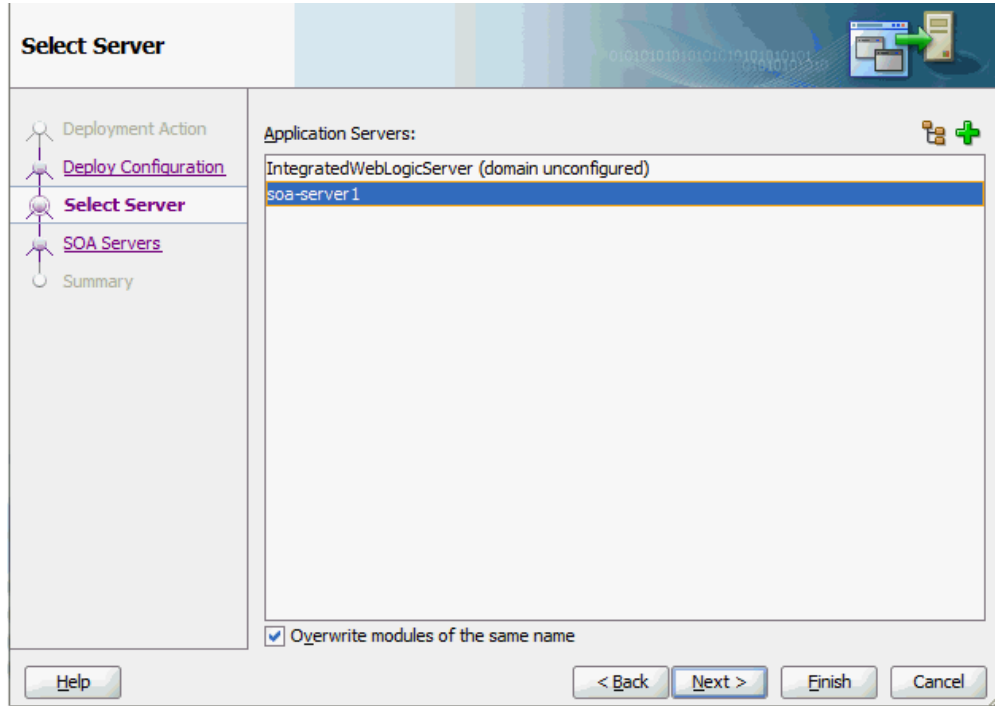

4. In the SOA Servers page, accept the default target SOA Server ('soa-server1') selection.

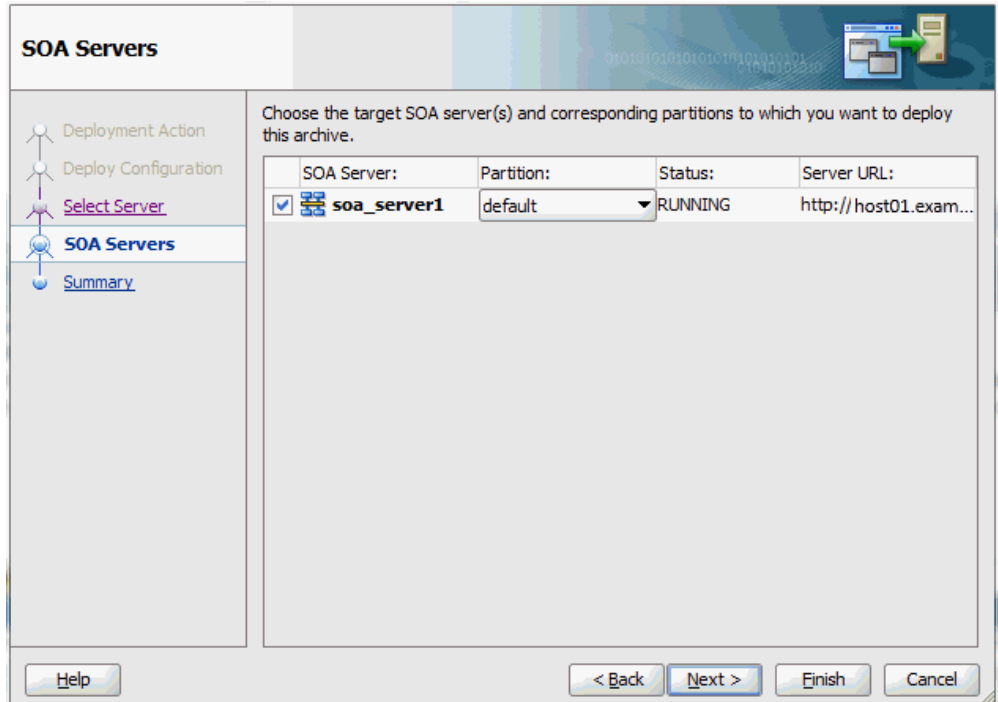

Click **Next** and **Finish**.

If you are deploying the composite for the first time from your Oracle JDeveloper session, the Authorization Request window appears. Enter username and password information specified during Oracle SOA Suite installation. Click **OK**.

5. Deployment processing starts. Monitor deployment progress and check for successful compilation in the SOA - Log window.

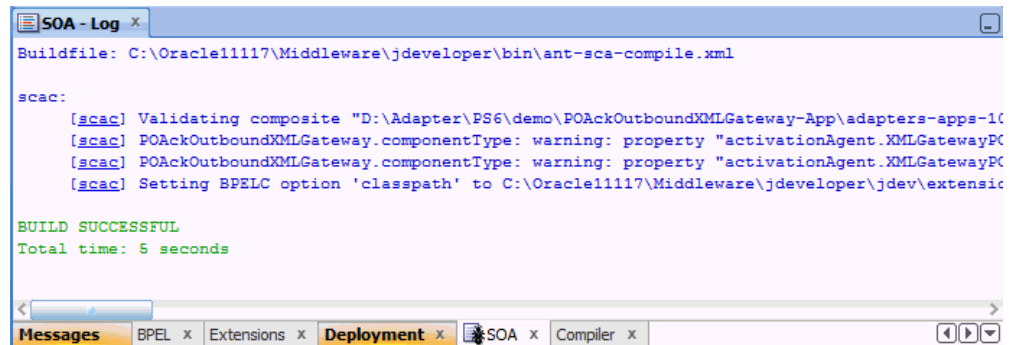

Verify that the deployment is successful in the Deployment - Log window.

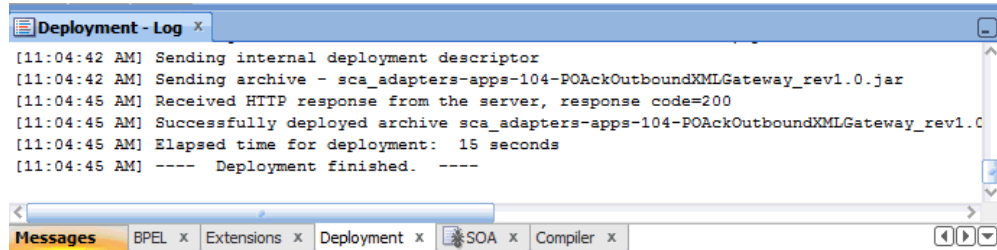

## Testing the SOA Composite Application with BPEL Process

In Oracle E-Business Suite, you can check for outbound transactions that have been processed by the XML Gateway and delivered to the Transaction Agent by using the Transaction Monitor. You can also use the Transaction Monitor to resend an outbound document if necessary.

**Note:** For details on using the Transaction Monitor, see *Oracle XML Gateway User's Guide*. This guide is part of the Oracle E-Business Suite Documentation Library which can be accessed on the Oracle Technology Network (OTN).

If you have used a File Adapter to write outbound messages from Oracle E-Business Suite to files, you can check the output directory location for the presence of these files after the BPEL process contained in a SOA Composite application has been executed.

To validate the design-time tasks created earlier, you can log in to Oracle E-Business Suite to manually create and book the order as well as generate the order acknowledgement by submitting a Workflow Background Process concurrent request.

### To manually test the SOA Composite application with BPEL process:

1. Log in to Oracle E-Business Suite with the XML Gateway responsibility.  
This is to ensure that the XML Gateway trading partner is set up correctly so that a purchase order can have a valid customer that has been defined.
2. Select Define Trading Partner from the navigation menu to access the Trading Partner Setup window.
3. Enter the header values on the Trading Partner Setup form as follows:
  - Trading Partner Type: Customer
  - Trading Partner Name: Business World
  - Trading Partner Site: Enter a trading partner site information, such as 2391 L Street, San Jose, CA 95106.

- Company Admin Email: Enter a valid e-mail address.
4. Enter the following trading partner details:
    - Transaction Type: ECX
    - Transaction SubType: CBODO
    - Standard Code: OAG
    - External Transaction Type: BOD
    - External Transaction SubType: CONFIRM
    - Direction: Out
    - Map: ECX\_CBODO\_OAG72\_OUT\_CONFIRM
    - Connection / Hub: DIRECT
    - Protocol Type: BPEL
    - Username: 'operation'
    - Password: Enter the associated password twice.
    - Protocol Address: 'http://ebssoa.sample.com'
    - Source Trading Partner Location Code: BWSANJOSE
  5. Save your work.

To successfully generated PO Acknowledgement, you need to create an order and then manually book the order through Order Management.

Use the following steps to create an order and then manually book the order:

1. Switch to Order Management Super User, Vision Operations (USA) responsibility and select Customer > Standard from the navigation menu to open the Enter Customer form.
2. Search on the 'Business World' in the Name field and click **Find**.
3. Select the Business World with the following information from the search results.
  - Account Name: Business World
  - Registry ID: 2813

- Identifying check box: checked
  - Address: 2391 L Street, San Jose, CA 95106
  - Country: United States of America
4. Select row with the following entries:
    - Account Number:1608
    - Account Description: Business World
    - Status: Active
  5. Click **Details** to open the Customer Information page.
  6. Click **Details** in the row with the Business World with Address '2391 L Street, San Jose, CA 95106' and Country 'United States of America'. This opens the Customer Account page.
  7. Enter 'BWSANJOSE' in the EDI Location field.
  8. In the Business Purposes tab, create a new row with the following values:
    - Usage: Sold To
    - Check on the 'Primary' check box

Save your work.

Use the following steps to generate acknowledgement for already created order:

1. Log in to Oracle E-Business Suite with the Order Management Super User, Vision Operations (USA) responsibility. Select Order Returns > Sales Order to open the Sales Orders form.
2. Retrieve the order that you have created earlier by entering the order ID in the Customer PO field. For example, enter `order_id_01`.
3. Click **Book Order** to book the order.

### Booking an Order

Sales Orders (Vision Operations) - 64624, Business World

Order Information    Line Items

Default

Main    Others

Customer	Business World	Order Number	64624
Customer Number	1608	Order Type	Mixed
Customer PO	order_id_01	Date Ordered	05-MAR-2009 04:28:18
Customer Contact		Price List	Corporate
Operating Unit	Vision Operations	Salesperson	Sprague, Mr. Howard
Ship To Location	San Jose (OPS)	Status	Booked
	2391 L Street	Currency	USD
	San Jose, CA, 95106, US	Subtotal	0.00
Bill To Location	San Jose (OPS)	Tax	0.00
	2391 L Street	Charges	0.00
		Total	0.00
	San Jose, CA, 95106, US		

Actions    Related Items    Configurator    Availability    Book Order

4. Switch to the System Administrator responsibility and select Request > Run.
5. Select **Single Request** and click **OK**.
6. Enter the following information in the Submit Request form:

## Specifying Parameters

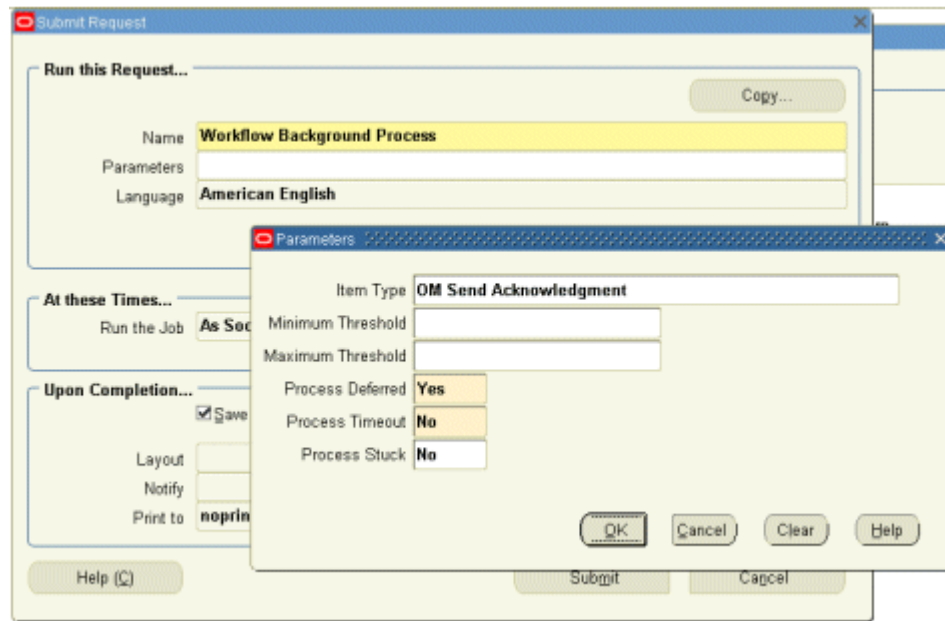

- Name: Workflow Background Process
  - Enter the following parameters:
    - Item Type: OM Send Acknowledgement
    - Process Deferred: Y
    - Process Timeout: N
    - Process Stuck: N
  - Click **OK**.
7. Click **Submit** to submit 'send acknowledgement' request.
  8. View your request by entering the request ID to ensure its status is 'Success'.

On approval of the order, Oracle E-Business Suite triggers the workflow that creates the Purchase Order Acknowledgement flow and sends out the PO Acknowledgement as an XML file. The workflow delivers the Confirm BOD as the PO Acknowledgement to the ECX\_OUTBOUND queue for delivery to the other system.

On the other hand, Oracle BPEL PM listens to the ECX\_OUTBOUND queue for the message with the correlation Id = "BPEL" which is the same id for this outbound message. The Confirm BOD as the PO Acknowledgement is written as XML file using



File Adapter.

Since the BPEL process contained in a SOA Composite application is deployed, the process is continuously polling the ECX\_OUTBOUND queue for PO acknowledgement. It also writes PO Acknowledgement in the physical directory mentioned in `composite.xml` after receiving from XML Gateway ECX\_OUTBOUND queue.

You can open file in text editor and search for ORIGREF element. Its value should be same as order id (`order_id_01` whose order was booked).



```
<YEAR>2002</YEAR>
<MONTH>10</MONTH>
<DAY>09</DAY>
<HOUR>16</HOUR>
<MINUTE>45</MINUTE>
<SECOND>47</SECOND>
<SUBSECOND>356</SUBSECOND>
<TIMEZONE>-0800</TIMEZONE>
</DATETIME>
</CNTROLAREA>
<STATUSLVL>00</STATUSLVL>
<DESCRIPTN>Inbound Process PO Document</DESCRIPTN>
<ORIGREF>order_id_01</ORIGREF>
<USERAREA></USERAREA>
<CONFIRMMSG>
  <DESCRIPTN></DESCRIPTN>
  <REASONCODE></REASONCODE>
  <USERAREA></USERAREA>
</CONFIRMMSG>
</CONFIRM>
</CONFIRM_BOD>
</DATAAREA>
</CONFIRM_BOD_004>
"POAck090306030955.xml" 71L, 2342C                               66,16                               Bot
```

## Troubleshooting

If you experience problems with your Oracle XML Gateway integration, you can take the following troubleshooting steps:

- Confirm that you have the correct settings for the following elements of the trading partner setup:
  - Standard Code
  - Transaction Type
  - Transaction Subtype
  - Source Trading Partner Location Code (Party Site ID)

- Confirm that the correct transaction is enabled for the trading partner.
- Check the status of the XML transaction in Transaction Monitor.
- Ensure that the document number is unique within this transaction type.
- For inbound transactions, confirm that ECX Listeners are running.
- For outbound transactions, confirm that Background Engine is running.
- In the trading partner setup, ensure that the Protocol Type is set to BPEL.
- Specify the same correlation ID for Oracle Applications as for the Adapter.

The Adapter Configuration wizard of Adapter for Oracle Applications does not specify a correlation ID for XML Gateway transactions for inbound or outbound interfaces. Instead, a default correlation ID of BPEL is automatically set in the WSDL file. To make this configuration work, you must configure Oracle Applications to set the same correlation ID value of BPEL for the corresponding XML Gateway transactions.

If you want the Adapter to use a different correlation ID than the default, you need to configure a correlation ID in Oracle Applications, then edit the `Correlation="BPEL"` line contained in the `<jca:operation>` section of the adapter service WSDL. Replace BPEL with the string value of the correlation ID you specified in Oracle Applications.

Enable logging for Adapter to see if the issue is on the middleware side. How to enable logging for Adapter for Oracle Applications, see [Enabling Logging for Adapters](#), page 4-82.

---

## Using Business Events

This chapter covers the following topics:

- Overview of Business Events
- Design-Time Tasks for Outbound Business Events
- Creating a New SOA Composite Application with BPEL Process
- Creating a Partner Link
- Configuring the Receive Activity
- Adding a Partner Link for the File Adapter
- Configuring an Invoke Activity
- Configuring an Assign Activity
- Run-Time Tasks for Outbound Business Events
- Deploying the SOA Composite Application with BPEL Process
- Testing the SOA Composite Application with BPEL Process
- Troubleshooting

### Overview of Business Events

The *Oracle Workflow Business Event System* (BES) is an application service that leverages the Oracle Advanced Queuing (AQ) infrastructure to communicate business events between systems. The Business Event System consists of the Event Manager and workflow process event activities.

The Event Manager contains a registry of business events, systems, named communication agents within those systems, and subscriptions indicating that an event is significant to a particular system. Events can be raised locally or received from an external system or the local system through AQ. When a local event occurs, the subscribing code is executed in the same transaction as the code that raised the event, unless the subscriptions are deferred.

Subscriptions can include the following types of processing:

- Executing custom code on the event information
- Sending event information to a workflow process
- Sending event information to other queues or systems

Each business event represents a ready to use integration or extension point. Oracle E-Business Suite currently ships preconfigured with over 900 business events.

The uses of the Business Event System include:

- **System integration messaging hubs** - Business Event System can serve as a messaging hub for complex system integration scenarios. The Event Manager can be used to "hard-wire" routing between systems based on event and originator.
- **Distributed applications messaging** - Applications can supply Generate and Receive event message handlers for their business entities. For example, message handlers can be used to implement Master/Copy replication for distributed applications.
- **Message-based system integration** - You can set up subscriptions, which cause messages to be sent from one system to another when business events occur. In this way, you can use the Event Manager to implement point-to-point messaging integration.
- **Business-event based workflow processes** - You can develop sophisticated workflow processes that include advanced routing or processing based on the content of business events.
- **Non-invasive customization of packaged applications** - Analysts can register interesting business events for their Internet or intranet applications. Users of those applications can register subscriptions to those events to trigger custom code or workflow processes.

## Business Events Concepts

### Event

A business event is an occurrence in an Internet or intranet application or program that might be significant to other objects in a system or to external agents. For instance, the creation of a purchase order is an example of a business event in a purchasing application.

### Event Key

A string that uniquely identifies an instance of an event. Together, the event name,

event key, and event data fully communicate what occurred in the event.

### **Event Message**

A standard Workflow structure for communicating business events, defined by the datatype `WF_EVENT_T`. The event message contains the event data as well as several header properties, including the event name, event key, addressing attributes, and error information.

### **Event Activity**

A business event modeled as an activity so that it can be included in a workflow process.

### **Event Data**

A set of additional details describing an event. The event data can be structured as an XML document. Together, the event name, event key, and event data fully communicate what occurred in the event.

### **Event Subscription**

A registration indicating that a particular event is significant to a system and specifying the processing to perform when the triggering event occurs. Subscription processing can include calling custom code, sending the event message to a workflow process, or sending the event message to an agent.

### **Deferred Subscription Processing**

If you do not want subscriptions for an event to be executed immediately when the event occurs, you can defer the subscriptions. In this way you can return control more quickly to the calling application and let the Event Manager execute any costly subscription processing at a later time.

### **Agent**

An agent is a named point of communication within a system. Communication within and between systems is accomplished by sending a message from one agent to another. A single system can have several different agents representing different communication alternatives. For example, a system may have different agents to support inbound and outbound communication, communication by different protocols, different propagation frequencies, or other alternatives.

### **Business Event Groups**

A business event group is a type of event that contains multiple individual business events. Once an event group is defined, a subscription that is registered for an event group will be executed when any of the individual events within it is triggered.

With the support for business event groups, different business events belonging to an even group can be handled through a single partner link. A service created for an event group would be able to dequeue payloads corresponding to any of the events within the group.

To support existing partner links for outbound business events which are part of an event group, a workaround has to be followed. For detailed information, see Support for Business Events through Existing Partner Links, page B-1.

**Note:** If individual events under a group are subscribed, then two messages would be enqueued into the WF\_BPEL\_Q queue. Users requiring only one message would need to disable the subscription for the individual event which enqueues the messages into WF\_BPEL\_Q.

For information about creating a partner link with a business event group, see Creating a Partner Link with a Business Event Group, page 6-16.

## Design-Time Tasks for Outbound Business Events

This section discusses the process of configuring Adapter for Oracle Applications to create business event outbound subscriptions. It describes the tasks required to configure Adapter for Oracle Applications using the Adapter Configuration Wizard in Oracle JDeveloper.

### Creating Service Artifacts for Business Event Consumption

While creating a partner link for listening to a business event, the following tasks are performed behind the scenes:

- Creation of WF\_BPEL\_Q queue
- Creation of an entry for WF\_BPEL\_Q in WF\_AGENTS table
- Creation of a subscription for the event being listened to

To facilitate re-creating the above entries on a different Oracle E-Business Suite instance, a script is generated in the project folder. In addition, a drop script is created which can be run manually on the corresponding instance to clean up all the tasks performed above. Running the drop script is optional, and is not recommended. The drop script would delete the WF\_BPEL\_Q queue, which can impact other composites, listening to events on the same Oracle E-Business Suite instance.

### Multiple BPEL Processes Consuming the Same Business Event

Adapter for Oracle Applications can handle multiple BPEL processes consuming the same business event. Adapter for Oracle Applications creates only single subscription for a particular business event regardless of the number of BPEL process consuming it. Internally, this subscription forwards business event message to a multi-consumer AQ. Since each BPEL process is a unique consumer for the event, when the message is

placed in the queue, all BPEL processes are notified. Therefore, as a user you do not need to create a separate subscription for each BPEL process. All you need to do is to create the service for the event, and Adapter for Oracle Applications will take care of message delivery to each BPEL process.

For example, if there are three BPEL processes (BPEL1, BPEL2, and BPEL3) that want to consume the same business event (such as BE1 event). For each BPEL process, you create a service for the BE1 event using Adapter for Oracle Applications. Adapter for Oracle Applications in turn creates a single subscription for all the three BPEL processes - BPEL1, BPEL2, and BPEL3. This subscription puts BE1 event message in multi-consumer AQ.

At run time, when a BE1 event is raised, since the subscription is applicable to all the three BPEL processes, all these three deployed BPEL processes will be activated and would receive the same BE1 event message.

### **SOA Composite Application with BPEL Process Scenario**

Take a PO XML Raise business event as an example.

When a purchase order is created and approved, a purchase order approved business event `oracle.apps.po.evnt.xmlpo` is raised. The subscription to this event is created in the background to listen to the business event and get event details. The event data will be passed through BPEL process activities and then written in XML file as an output file.

When the SOA Composite application with BPEL process has been successfully executed after deployment, you should get the same purchase order information from the output file once a purchase order is approved.

### **Prerequisites to Configure Outbound Business Events**

- The WF\_Deferred Agent Listener must be up and running on the target instance.
- The event should be enabled for BPEL to subscribe to it. The event should not be in the disabled mode.

### **SOA Composite Application with BPEL Process Creation Flow**

Based on the PO XML Raise business event scenario, the following design-time tasks are discussed in this chapter:

1. Create a new SOA Composite application with BPEL process, page 6-6.
2. Create a partner link, page 6-10.
3. Configure a Receive activity, page 6-21.
4. Add a partner link for the file adapter, page 6-23.
5. Configure an Invoke activity, page 6-30.

6. Configure an Assign activity, page 6-32.

## Creating a New SOA Composite Application with BPEL Process

To create a new SOA Composite application with BPEL process:

1. Launch Oracle JDeveloper.
2. Click **New Application** in the Application Navigator.

The Create SOA Application - Name your application page is displayed.

### The Create SOA Application - Name your application Page

The screenshot shows the 'Create SOA Application - Step 1 of 3' dialog box. The title bar reads 'Create SOA Application - Step 1 of 3'. The main heading is 'Name your application'. On the left, there is a tree view with 'Application Name' selected, 'Project Name', and 'Project SOA Settings'. The right pane contains several fields: 'Application Name' with the text 'GetPOAckBusinessEvent', 'Directory' with 'C:\JDeveloper\mywork\GetPOAckBusinessEvent' and a 'Browse...' button, 'Application Package Prefix' (empty), and 'Application Template' with a list of three options: 'Java Desktop Application (ADF)', 'Java EE Web Application', and 'SOA Application' (which is selected). At the bottom, there are buttons for 'Help', '< Back', 'Next >', 'Finish', and 'Cancel'.

3. Enter an appropriate name for the application in the **Application Name** field and select **SOA Application** from the Application Template list.  
Click **Next**. The Create SOA Application - Name your project page is displayed.
4. Enter an appropriate name for the project in the **Project Name** field. For example, GetPOAckBusinessEvent.



### The Create SOA Application - Name your project Page

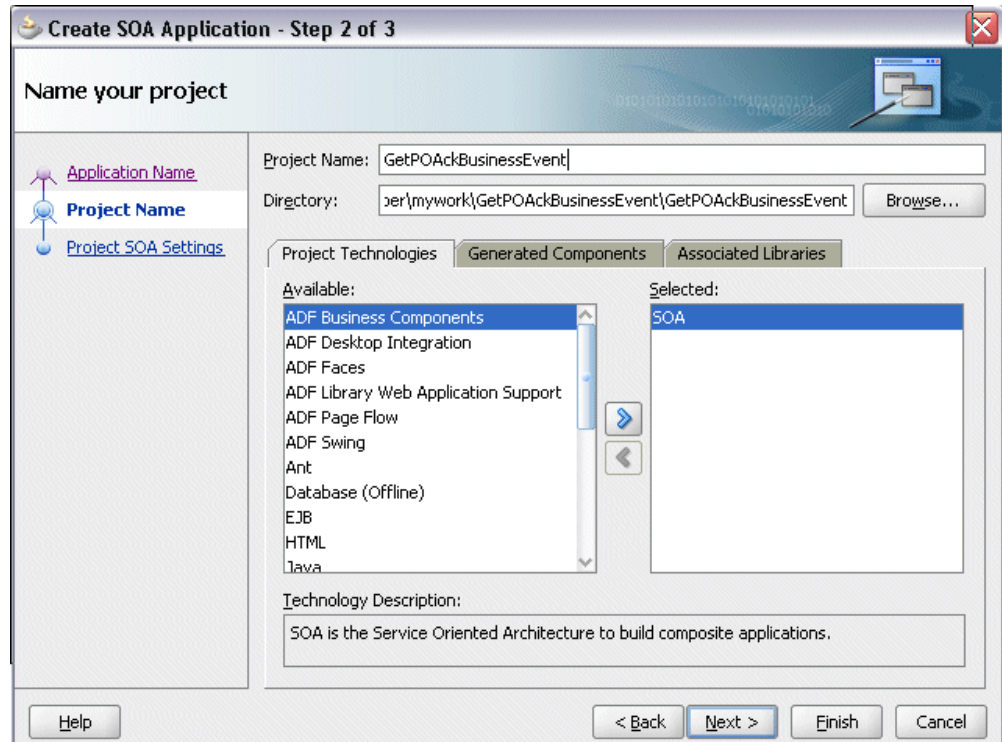

5. In the Project Technologies tab, ensure that **SOA** is selected from the Available technology list to the Selected technology list.

Click **Next**. The Create SOA Application - Configure SOA settings page is displayed.

### The Create SOA Application - Configure SOA settings Page

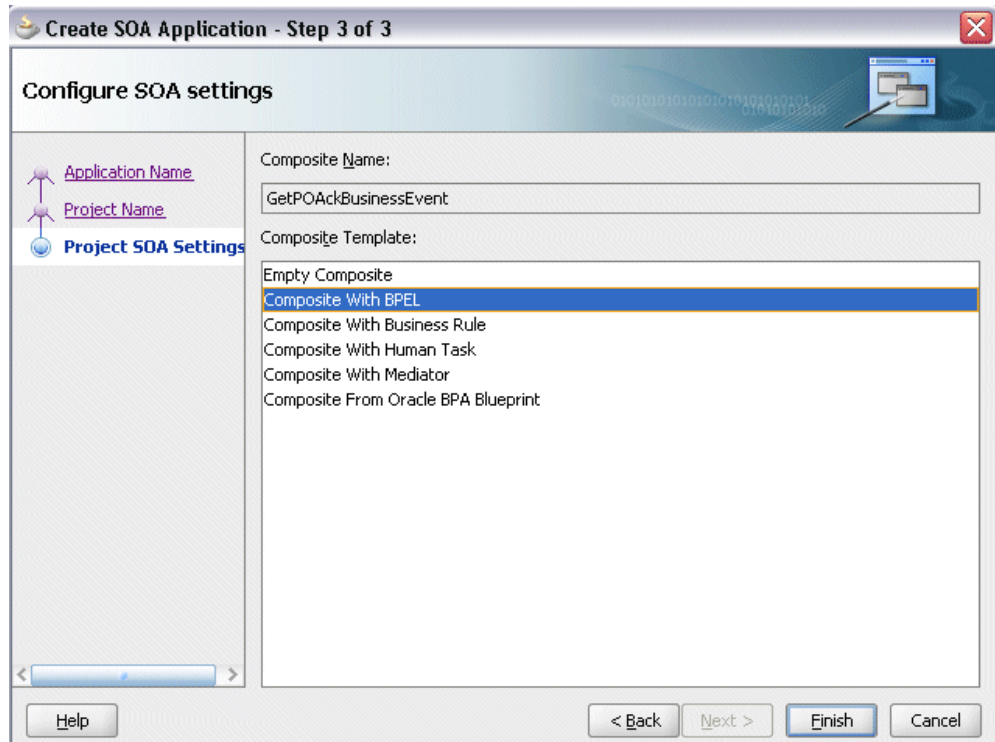

6. Click **Finish**. You have created a new application, and a SOA project. This automatically creates a SOA Composite.

The Create BPEL Process page is displayed.

### The Create BPEL Process Page

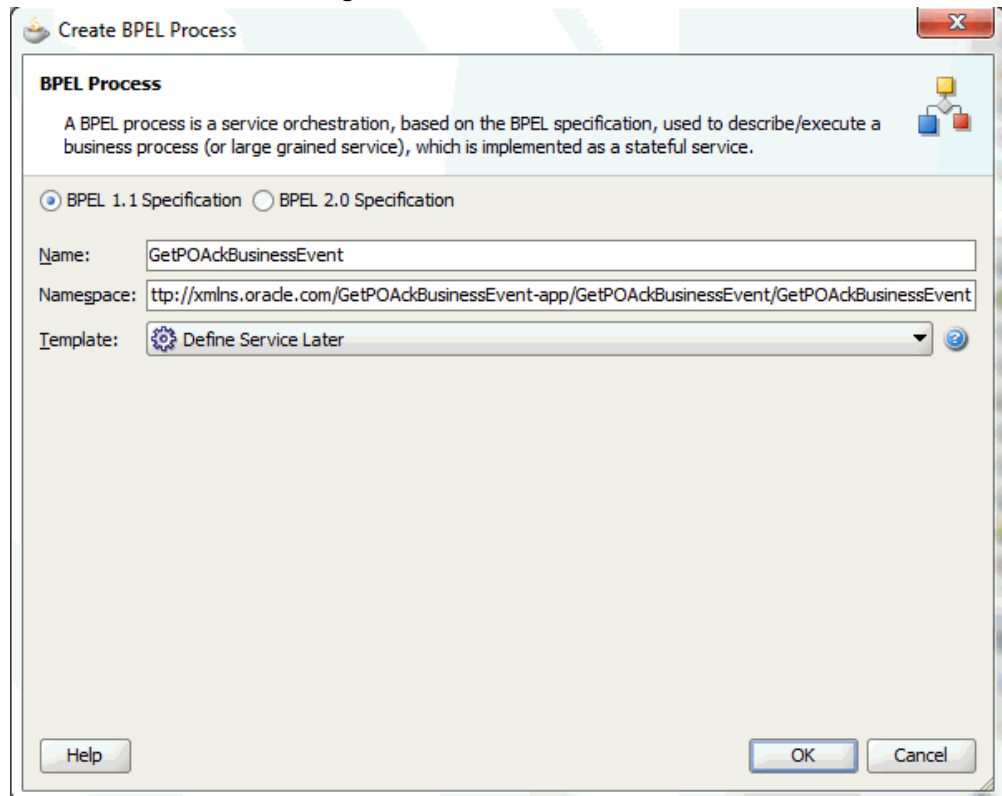

7. Leave the default **BPEL 1.1 Specification** selection unchanged. This creates a BPEL project that supports the BPEL 1.1 specification.

Enter an appropriate name for the BPEL process in the **Name** field. For example, `GetPOAckBusinessEvent`.

Select **Define Service Later** from the **Template** field. Click **OK**.

An empty BPEL process is created. The required source files including `bpel` and `wsdl`, using the name you specified (for example, `GetPOAckBusinessEvent.bpel` and `GetPOAckBusinessEvent.wsdl`) and `composite.xml` are also generated.

### An Empty BPEL Process

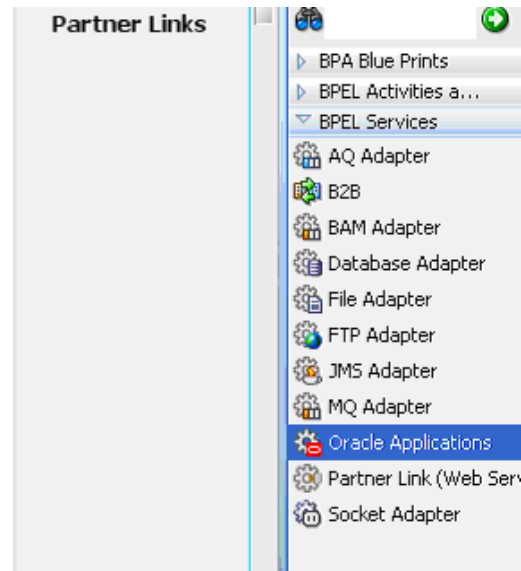
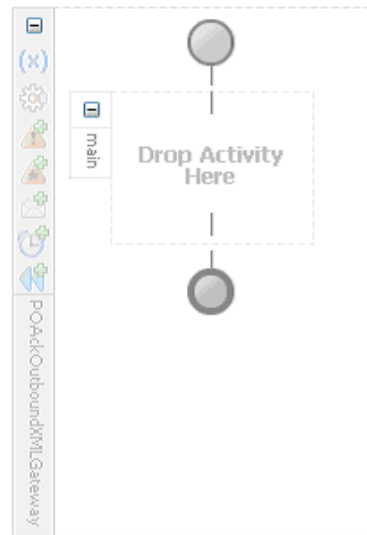

## Creating a Partner Link

Configuring an outbound business event requires creating a partner link to allow the outbound event to be published.

This task adds a partner link to the BPEL process. A partner link defines the link name, type, and the role of the BPEL process that interacts with the partner service.

### To add a partner link:

1. Click **BPEL Services** in the Component palette.

Drag and drop **Oracle Applications** from the BPEL Services list into the right Partner Link swim lane of the process diagram. The Adapter Configuration Wizard Welcome page appears. Click **Next**.

2. Enter a service name in the **Service Name** field. For example, `GetPOApprovalEvent`.

**Enter the Service Name**

Adapter Configuration Wizard - Step 2 of 4

**Service Name**

Enter a Service Name.

Service Type: Oracle Applications

Service Name: GetPOApprovalEvent

Help < Back Next > Finish Cancel

Click **Next**. The Service Connection dialog appears.

### Specifying a Database Service Connection

The screenshot shows a window titled "Adapter Configuration Wizard - Step 3 of 4" with a close button in the top right corner. The main heading is "Service Connection". Below the heading, there is a blue banner with a gear icon and binary code. The text reads: "A Database Connection is required to configure this adapter. Select a database connection already defined in your project or create a New Connection." Below this, there is a "Connection:" dropdown menu with "OracleAppsConnection" selected. To the right of the dropdown are three icons: a green plus sign, a pencil, and a key. Below the dropdown, the following fields are displayed: "User Name: apps", "Driver: oracle.jdbc.OracleDriver", and "Connect String: jdbc:oracle:thin:@localhost:1521:sid01". Below these fields, there is a note: "Specify the JNDI name for the database. Note: The deployment descriptor of the Oracle Applications adapter must associate this JNDI name with configuration properties required by the adapter to access the database." Below the note is a "JNDI Name:" text box containing "eis/Apps/OracleAppsConnection". At the bottom of the window, there are four buttons: "Help", "< Back", "Next >", "Finish", and "Cancel".

3. You can perform either one of the following options for your database connection:

**Note:** You need to connect to the database where Oracle Applications is running.

- You can create a new database connection by clicking the **Create a New Database Connection** icon.

How to define a new database connection, see *Create a New Database Connection*, page 5-13.

- You can select an existing database connection that you have configured earlier from the **Connection** drop-down list.

The Service Connection page will be displayed with the selected connection information. The JNDI (Java Naming and Directory Interface) name corresponding to the database connection appears automatically in the **Database Server JNDI Name** field. Alternatively, you can specify a JNDI name.

**Note:** When you specify a JNDI name, the deployment descriptor of the Oracle Applications adapter must associate this JNDI name with configuration properties required by the adapter to access the database.

The JNDI name acts as a placeholder for the connection used when your service is deployed to the BPEL server. This enables you to use different databases for development and later for production.

**Note:** For more information about JNDI concepts, refer to *Oracle Fusion Middleware User's Guide for Technology Adapters*.

4. Once you have completed creating a new connection for the service, you can add a business event by browsing through the list available in Oracle Applications.

Click **Next**.

**For Oracle E-Business Suite Release 12:**

If you are connecting to Oracle E-Business Suite Release 12, then the **IREP File not present** dialog appears indicating that Adapter could not find the Oracle Integration Repository data file corresponding to the database you are connecting in your workspace. Absence of the data file would make browsing or searching of Integration Repository tree considerably slow. You can choose to extract the data file and create a local copy of the Integration Repository data file. Once it is created successfully, Adapter will pick it up automatically next time and retrieve data from your local Integration Repository.

You can select one of the following options:

- Click **Yes** to extract the Integration Repository data file.

### Extracting Integration Repository Data File

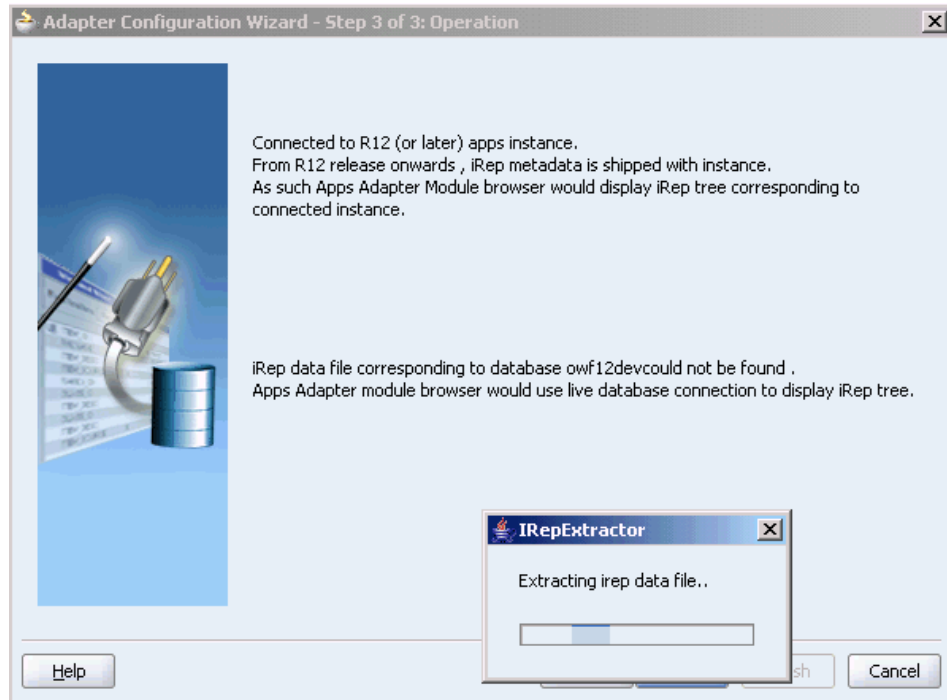

After the system successfully creates a local copy of the Integration Repository data file, next time when you connect to the database, you will find the **IRep Data File** field appears in the Operation dialog indicating where your local copy exists with the creation date and time as part of the file name.



### Using the Local Integration Repository Data File

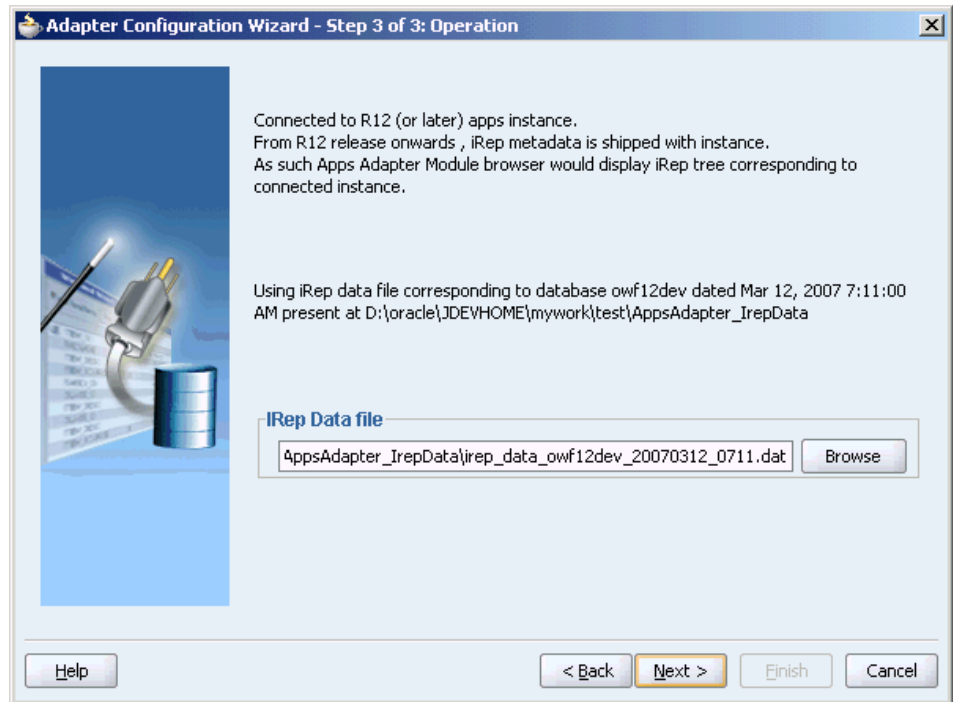

- Click **No** to query the Integration Repository data file from the live database you are connecting to display the Integration Repository tree.

Click **Next** in the Operation page to open the Oracle Applications Module Browser.

#### For Oracle E-Business Suite Release 11.5.9:

If you are connecting to an Oracle E-Business Suite Release 11.5.9 instance, you must select the interface type in the Adapter Configuration Wizard. Select **Workflow Business Event System** to proceed.

Click **Get Object** in the Application Interface dialog to open the Oracle Applications Module Browser.

5. The Oracle Applications Module Browser combines interface data from Oracle Integration Repository with information about the additional interfaces supported by Oracle Application Adapter, organized in a tree hierarchy.

To select a business event, expand the navigation tree to **Product Families > Other Interfaces > Business Events > Outbound**. The direction outbound is from the Oracle E-Business Suite perspective, in this case listening to business events from Oracle Applications. Select the appropriate business event, for example, **oracle.apps.po.event.xmlpo**, and click **OK**. The Application Interface page is displayed with selected business event.

## Selecting a Business Event from the Oracle Applications Module Browser

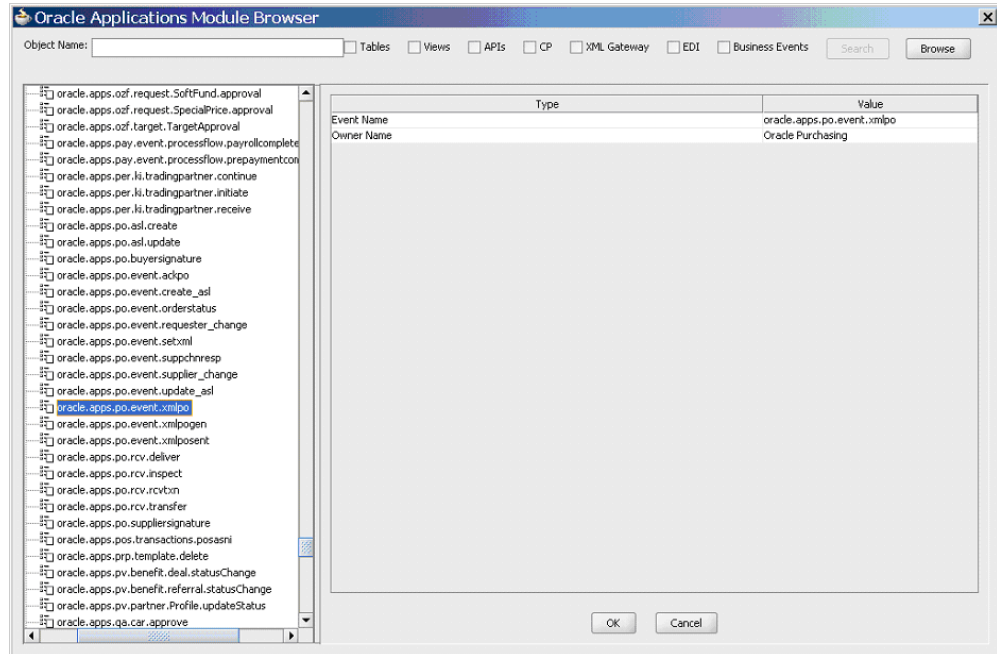

### Note: Creating a Partner Link with a Business Event Group

Business event groups appear under the **Other Interfaces > Business Events > Outbound > Groups** node from the Oracle Applications Module Browser.

If a business event group (such as **oracle.apps.fem.event.group.all**) is selected from the Groups node, detailed event group information including the event group owner name, generate function information if any, and each individual event contained in the selected event group is listed in the right pane of the Oracle Applications Module Browser window.

## Selecting a Business Event Group from the Oracle Applications Module Browser

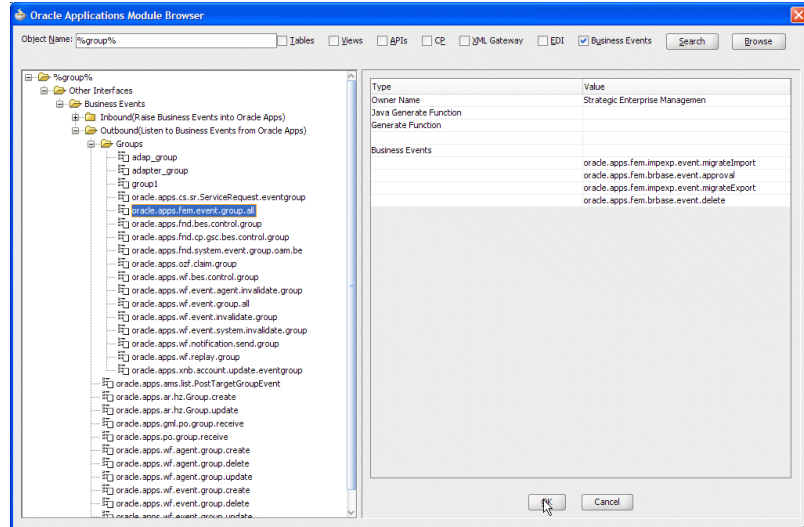

Additionally, select 'Any Schema' in the WF Event Schema Definition page later on for the business event payload. This allows XML payload of any schema to be attached to event payload. You can also verify the JCA Property "MessageSelectorRule" for the selected event group (described in Step 10) once the partner link is created.

This feature applies to Oracle E-Business Suite Release 12 and Release 11.5.10. For more information about business event groups, see Business Event Groups, page 6-3.

6. Click OK to display the Application Interface page.

## Adapter Configuration Wizard - Application Interface Page

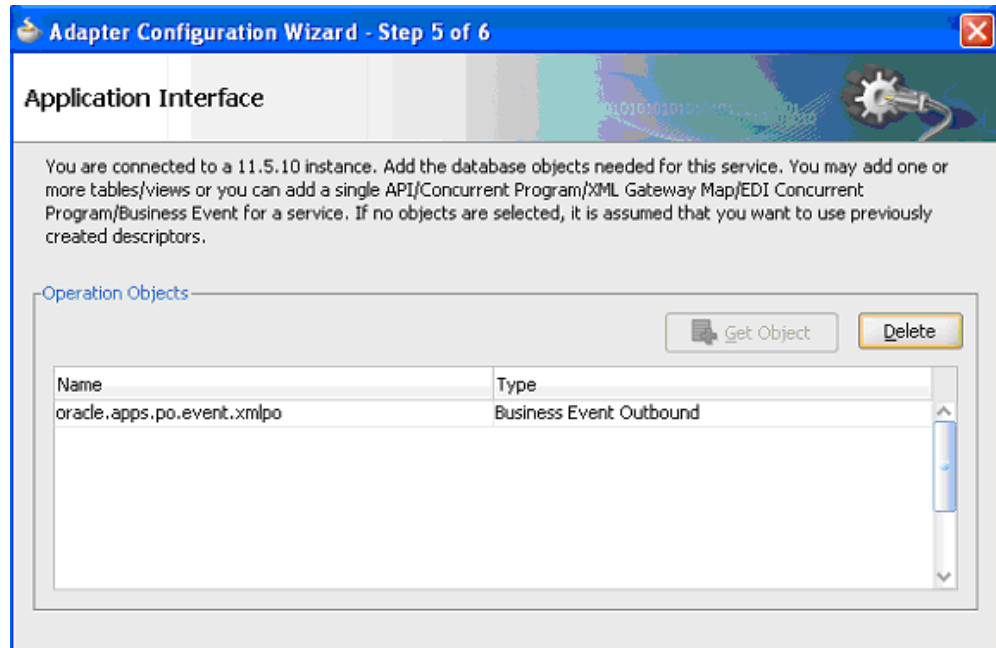

7. Click **Next** in the Application Interface page. The WF Event Schema Definition page for business event payload appears.
8. **Specifying Event Schema**

You must specify one of the following options to be used for the business event payload:

**Note:** When you select either the 'No Schema' or 'Any Schema' option, there is no need to further specify the schema information for your business event, and you will proceed to the next step.

- **No Schema**

If you select the No Schema option, then the payload data would be available in the form of string. This option also allows you to receive non-XML event payload.

- **Any Schema**

If you select the Any Schema option, then XML payload of any schema could be attached to event payload. You should select this option if you know the payload is XML, but not sure of its schema.

**Note:** If a business event group is selected for the partner link creation, select the 'Any Schema' option. This allows any schema to be attached to a business event group.

- **Specify Schema**

If you select the Specify Schema option, then the Schema Location and Schema Element fields become visible. You must specify the location of schema file and then select the schema element that defines the payload of outbound business event.

### Selecting Business Event Payload Schema

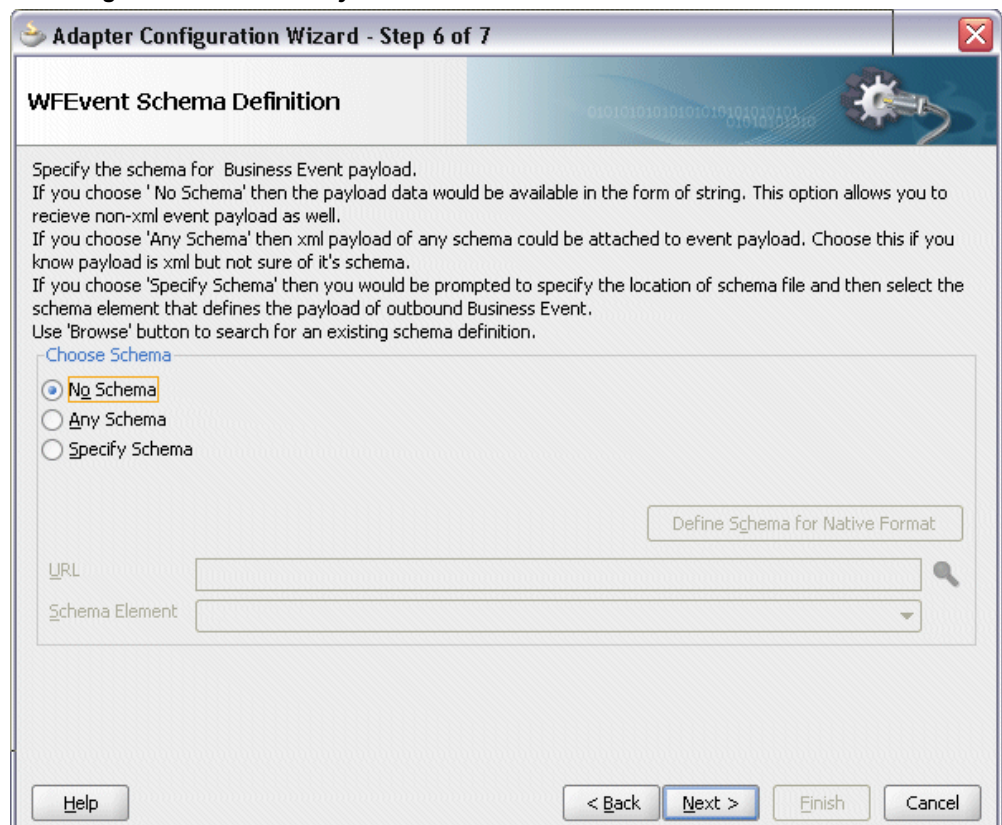

Select 'No Schema' and click **Next**.

9. The Finish page appears indicating that you have finished defining the business event service.

The wizard generates the GetPOApprovalEvent WSDL file corresponding to the **oracle.apps.po.event.xmlpo** business event service.

The main Create Partner Link dialog appears with the new WSDL file.

Click **Apply** and then **OK** to complete the partner link configuration.

#### **Partner Link Information**

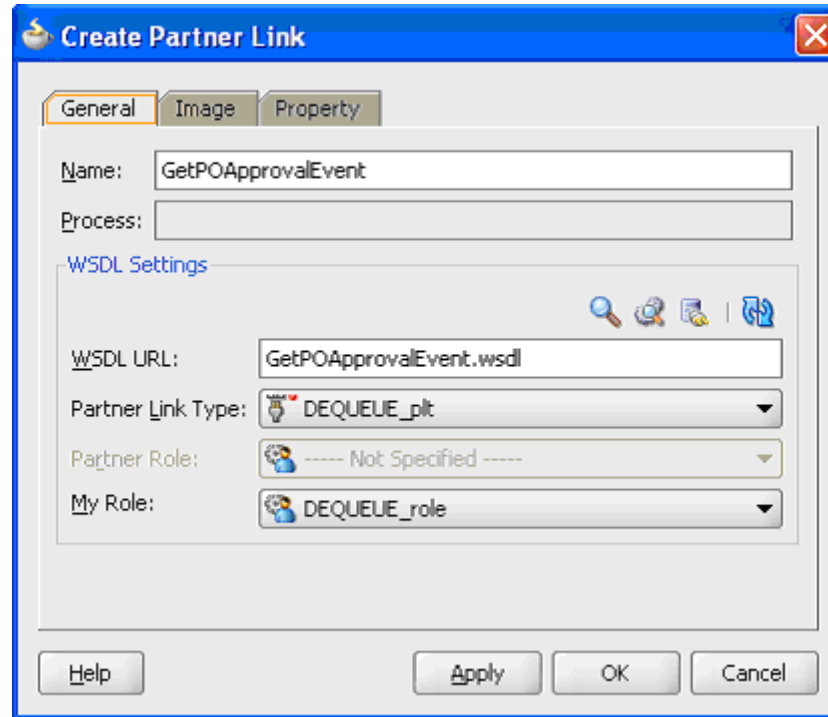

The partner link is created with the required WSDL settings, and is represented in the BPEL project by a new icon in the border area of the process diagram.

#### **10. Verifying JCA Property "MessageSelectorRule" for an Event Group Partner Link**

If a business event group is selected for the partner link creation, you can verify the business event group Jca property by selecting the partner link service (such as GroupBusinessEvent\_apps.jca from the SOA Content folder.

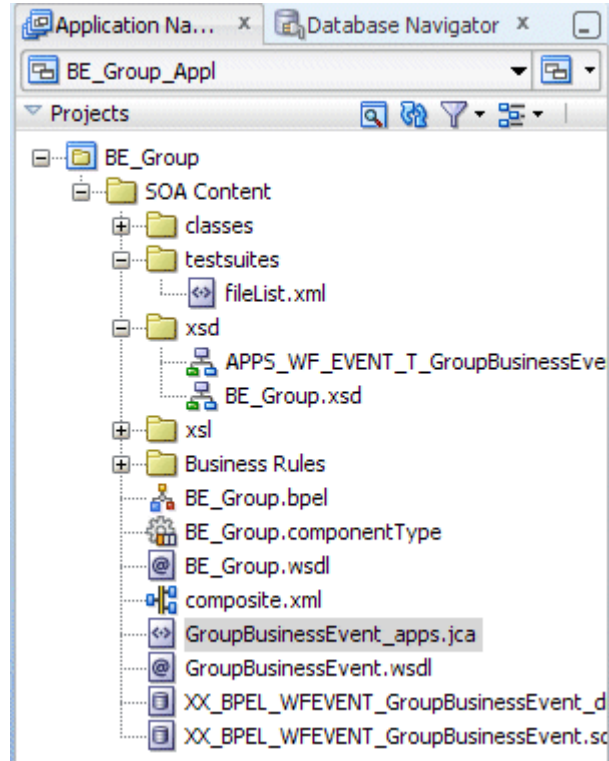

Click the Source tab to display the .jca file. Notice that the JCA property "MessageSelectorRule" contains the value of  
`value="tab.user_data.getvalueforparameter ('GROUP') = 'oracle.apps.fem.event.group.all'"`.

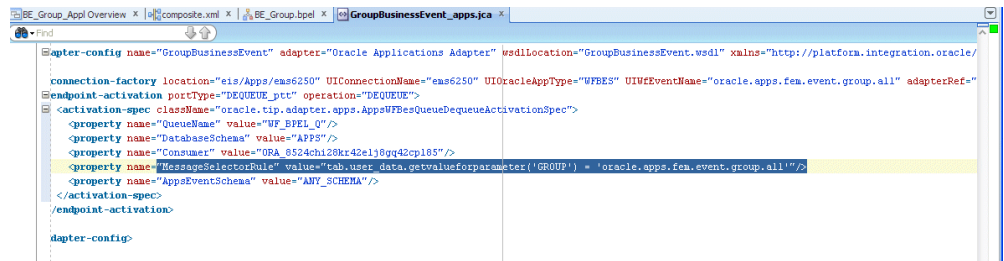

## Configuring the Receive Activity

The next task is to configure a Receive activity to receive event details from the partner link that you just configured for the Oracle Application adapter service as an input to the Assign activity.

### To configure the Receive activity:

1. In JDeveloper BPEL Designer, expand the **BPEL Constructs** from the Component

Palette. Drag and drop **Receive** from the BPEL activity list into the center swim lane of the process diagram.

2. Link the **Receive** activity to the partner link `GetPOApprovalEvent` that you just created earlier.

#### *Associating the Receive Activity with the Partner Link*

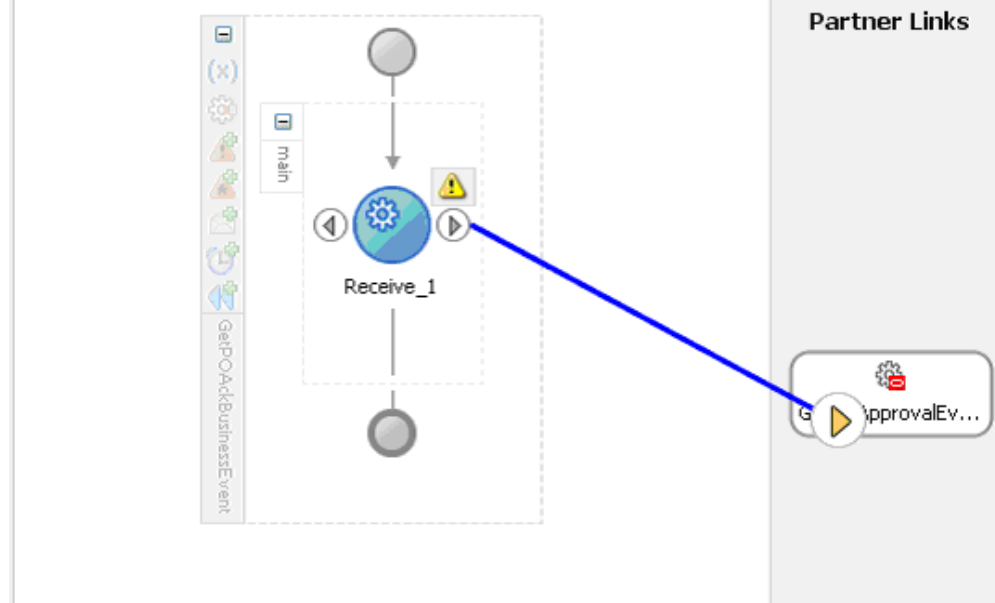

The Receive dialog appears.

3. Enter an appropriate name for the Receive activity.  
The Dequeue **Operation** is automatically selected since the partner link has been configured with an outbound business event.
4. Specify a **Variable** to receive the message data from the partner link by clicking the **Create** icon to the right of the Variable field. The **Create Variable** dialog box appears.
5. Click **OK** to accept the default name.



### Configuring the Receive Activity

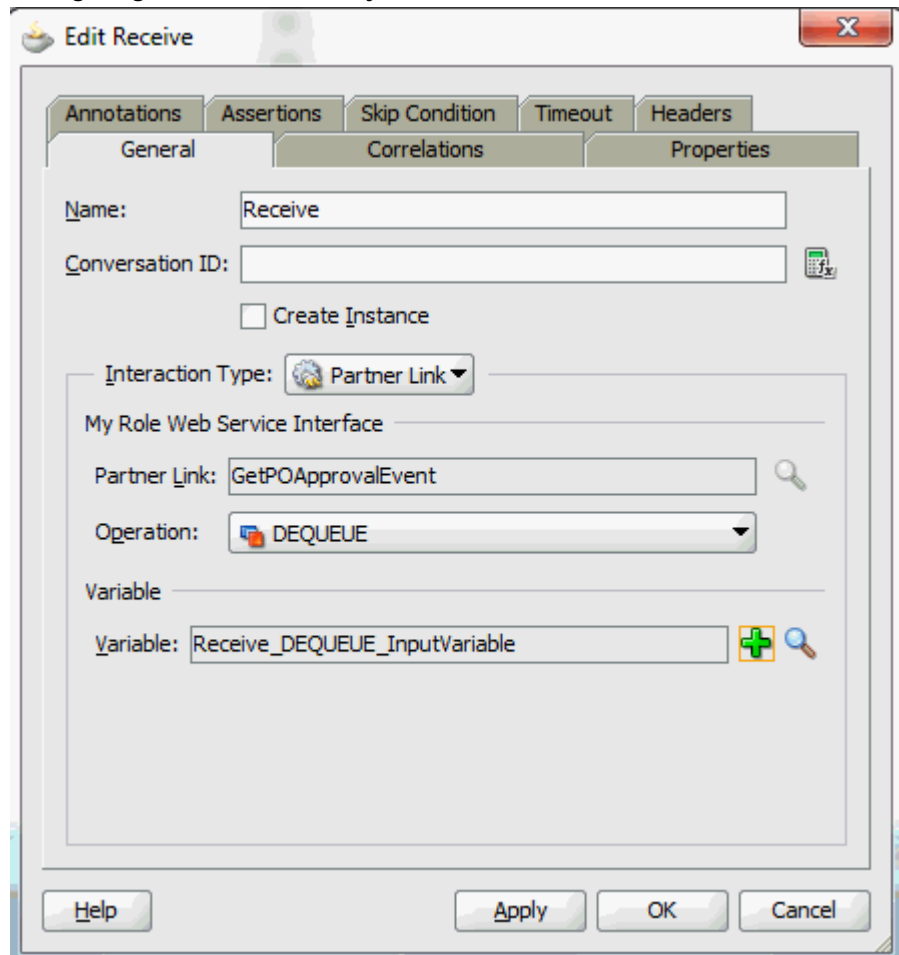

6. Click **Apply** in the Receive dialog, then click **OK**.

## Adding a Partner Link for the File Adapter

If you are configuring an outbound business event, you need to add another partner link for the file adapter. This allows the outbound business event to write the data to the XML file.

### To add a partner link for the file adapter:

1. In Oracle JDeveloper BPEL Designer, click **BPEL Services** in the Component palette.

Drag and drop **File Adapter** from the BPEL Services list into the right Partner Link swim lane of the process diagram. The Adapter Configuration Wizard Welcome

page appears.

Click **Next**.

2. In the Service Name page, enter a name for the file adapter service. For example, enter `WriteEventData`.

### ***Specifying the Service Name***

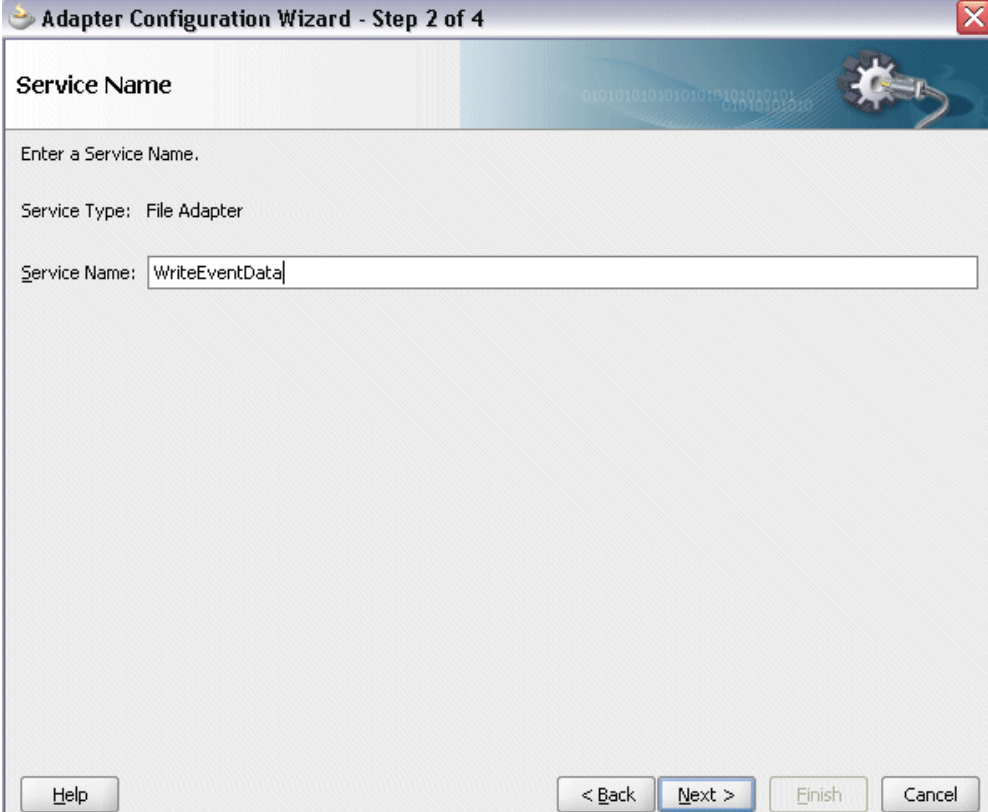

The screenshot shows a window titled "Adapter Configuration Wizard - Step 2 of 4". The window has a blue header bar with a gear icon and a close button. Below the header, the text "Service Name" is displayed. The main area contains the instruction "Enter a Service Name." and "Service Type: File Adapter". A text input field labeled "Service Name:" contains the text "WriteEventData". At the bottom of the window, there are four buttons: "Help", "< Back", "Next >", and "Cancel". The "Next >" button is highlighted with a blue border.

3. Enter a name for the file adapter service, for example, `WriteEventData`.
4. Click **Next**. The Adapter Interface page appears.

### Specifying the Adapter Interface

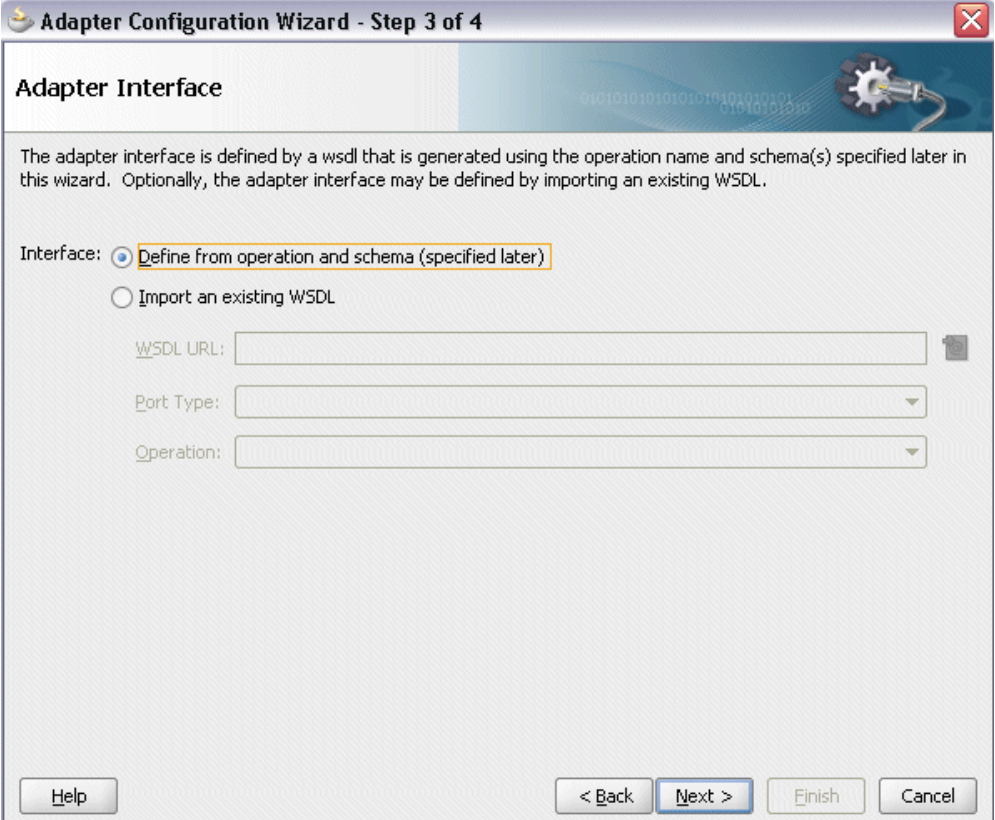

The screenshot shows a window titled "Adapter Configuration Wizard - Step 3 of 4". The main heading is "Adapter Interface". Below the heading, there is a descriptive paragraph: "The adapter interface is defined by a wsdl that is generated using the operation name and schema(s) specified later in this wizard. Optionally, the adapter interface may be defined by importing an existing WSDL." Under the heading "Interface:", there are two radio buttons. The first is "Define from operation and schema (specified later)", which is selected and highlighted with a yellow box. The second is "Import an existing WSDL". Below these are three input fields: "WSDL URL:" with a text box and a file icon; "Port Type:" with a dropdown menu; and "Operation:" with a dropdown menu. At the bottom of the window, there are four buttons: "Help", "< Back", "Next >", and "Cancel".

Select the **Define from operation and schema (specified later)** radio button and click **Next**.

5. In the Operation page, specify the operation type. For example, select the **Write File** radio button. This automatically populates the **Operation Name** field.

### Specifying the Operation

**Operation**

The File Adapter supports four operations. There is a Read File operation that polls for incoming files in your local file system, a Write File operation that creates outgoing files, a Synchronous Read File operation that reads the current contents of a file, and a List Files operation that lists file names in specified locations. Specify the Operation type and Operation Name. Only one operation per Adapter Service may be defined using this wizard.

Operation Type:  Read File  
 Write File  
 Synchronous Read File  
 List Files

Operation Name:

Help < Back Next > Finish Cancel

6. Click **Next** to access the File Configuration page.

### Configuring the Output File

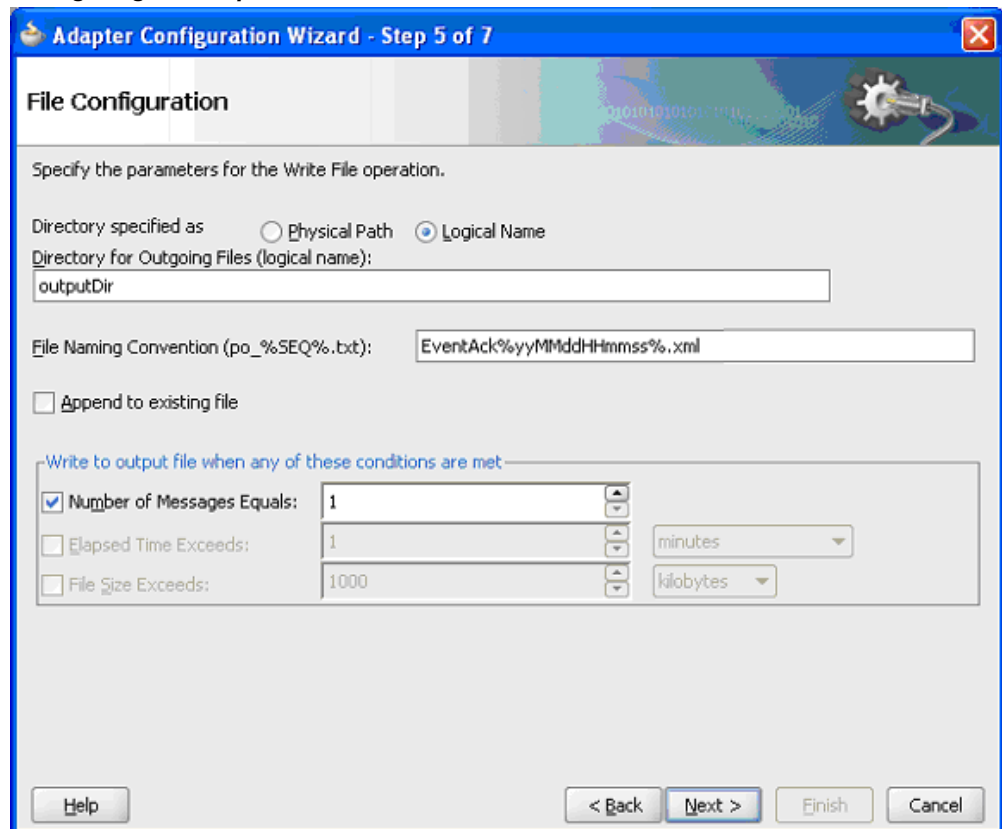

7. For the **Directory specified as** field, select the **Logical Name** radio button. Enter `outputDir` as the **Directory for Outgoing Files (logical name)** and specify a naming convention for the output file, such as `EventAck%yyMMddHHmmss%.xml`.

**Tip:** When you type a percent sign (%), you can choose from a list of date variables or a sequence number variable (SEQ) as part of the filename.

Confirm the default write condition: **Number of Messages Equals 1**.

8. Click **Next**, and the Messages page appears. For the output file to be written, you must provide a schema.
9. Click **Browse** to access the Type Chooser.
10. Expand the node by clicking **Project Schema Files > WF\_EVENT\_T.xsd**. Select **WF\_EVENT\_T** as the element and click **OK**.

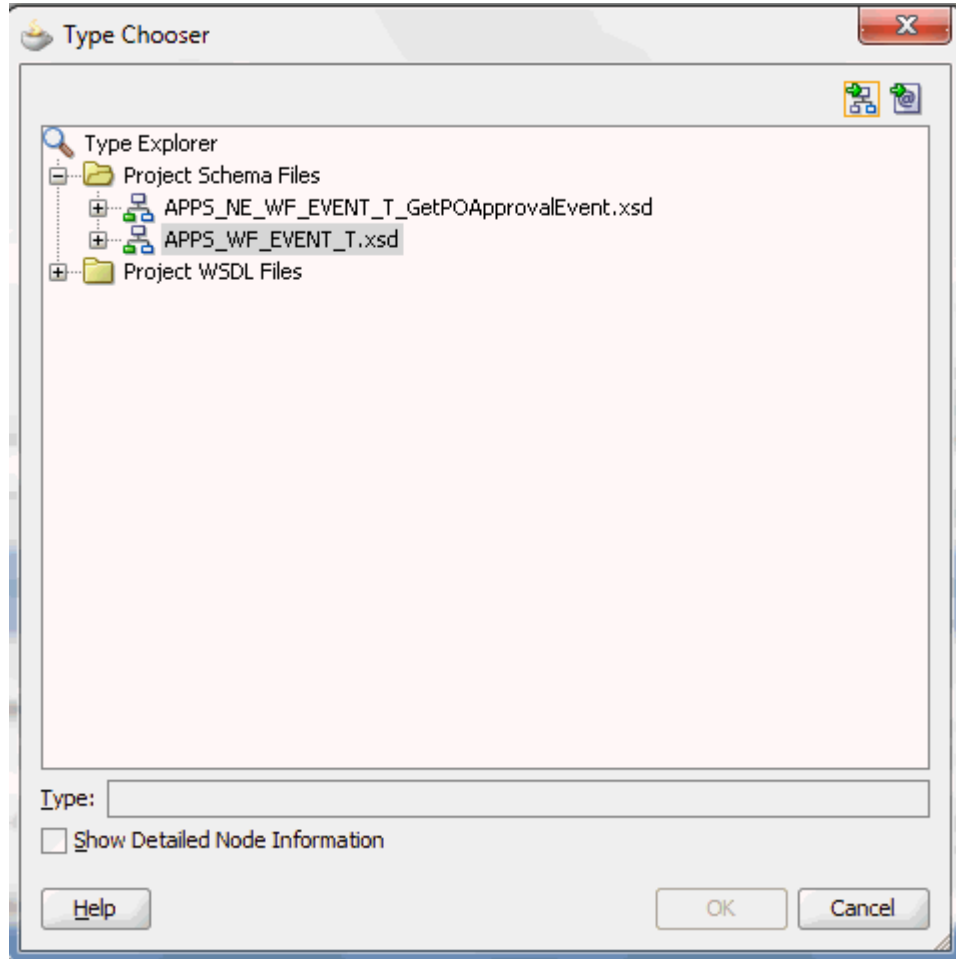

The selected schema information will be automatically populated in the URL and Schema Element fields.

### Populating the Selected Message Schema

**Messages**

Define the message for the Write File operation. Specify the Schema File Location and select the Schema Element that defines the messages in the outgoing files. Use the Browse button to find an existing schema definition. If you check 'Schema is Opaque', then you do not need to specify a Schema.

Message Schema

Native format translation is not required (Schema is Opaque)

URL

Schema Element

Help < Back Next > Finish Cancel

11. Click **Next** and then **Finish**. The wizard generates the WSDL file corresponding to the partner link. The main Create Partner Link dialog box appears, specifying the new WSDL file.

### Completing the Partner Link Configuration

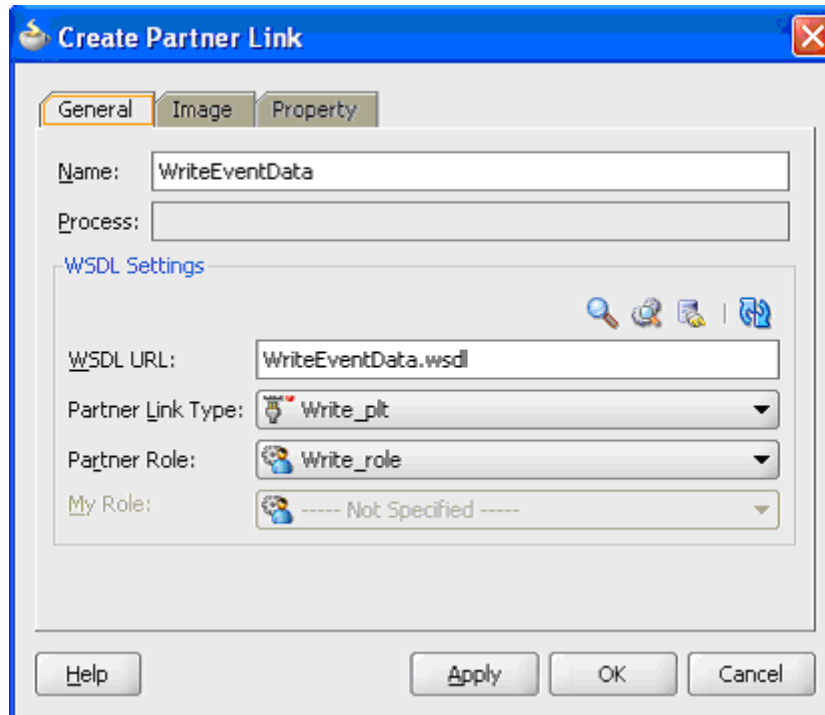

12. Click **Apply** and then **OK** to complete the configuration and create the partner link with the required WSDL settings for the File Adapter service.

## Configuring an Invoke Activity

After adding the File Adapter partner link, you need to configure an Invoke activity to associate it with the File Adapter link.

Through the Invoke activity, the business event information can be written to the XML file you specified as the output directory.

### To configure an Invoke activity:

1. In Oracle JDeveloper BPEL Designer, expand the **BPEL Constructs** from the Component Palette. Drag and drop an **Invoke** activity into the center swim lane of the process diagram after the **Receive** activity.
2. Link the Invoke activity to the `WriteEventData` File Adapter service.



### Associating Invoke with the File Adapter Link

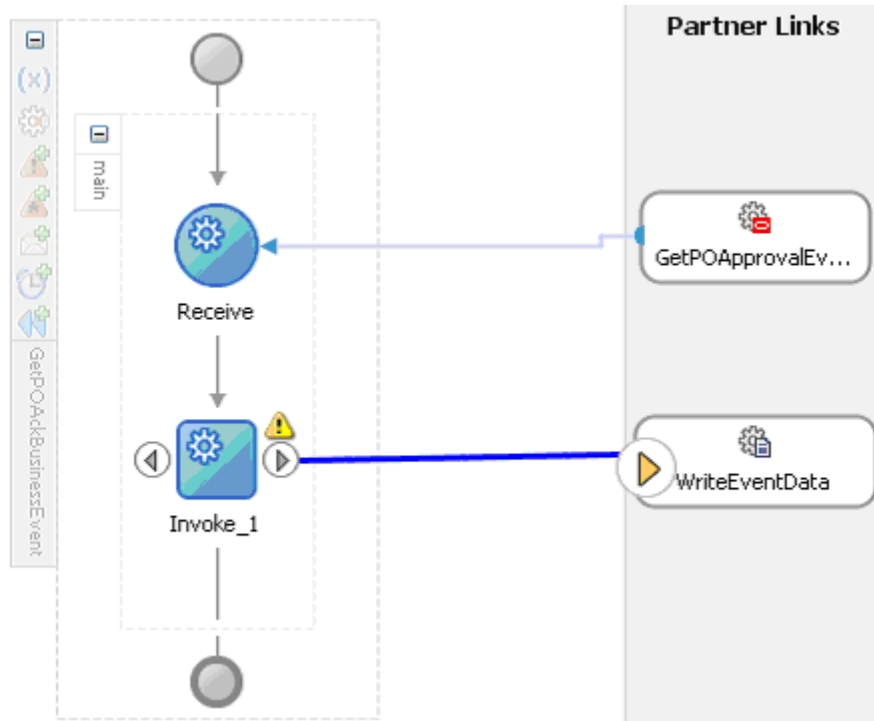

The Invoke activity will send event data to the partner link. The Edit Invoke dialog appears.

3. Enter a name for the Invoke activity, then click the **Create** icon next to the **Input Variable** field to create a new variable. The Create Variable dialog appears.
4. Select **Global Variable**, then enter a name for the variable. You can also accept the default name. Click **OK** to return to the Edit Invoke dialog.

### Editing the Invoke Activity

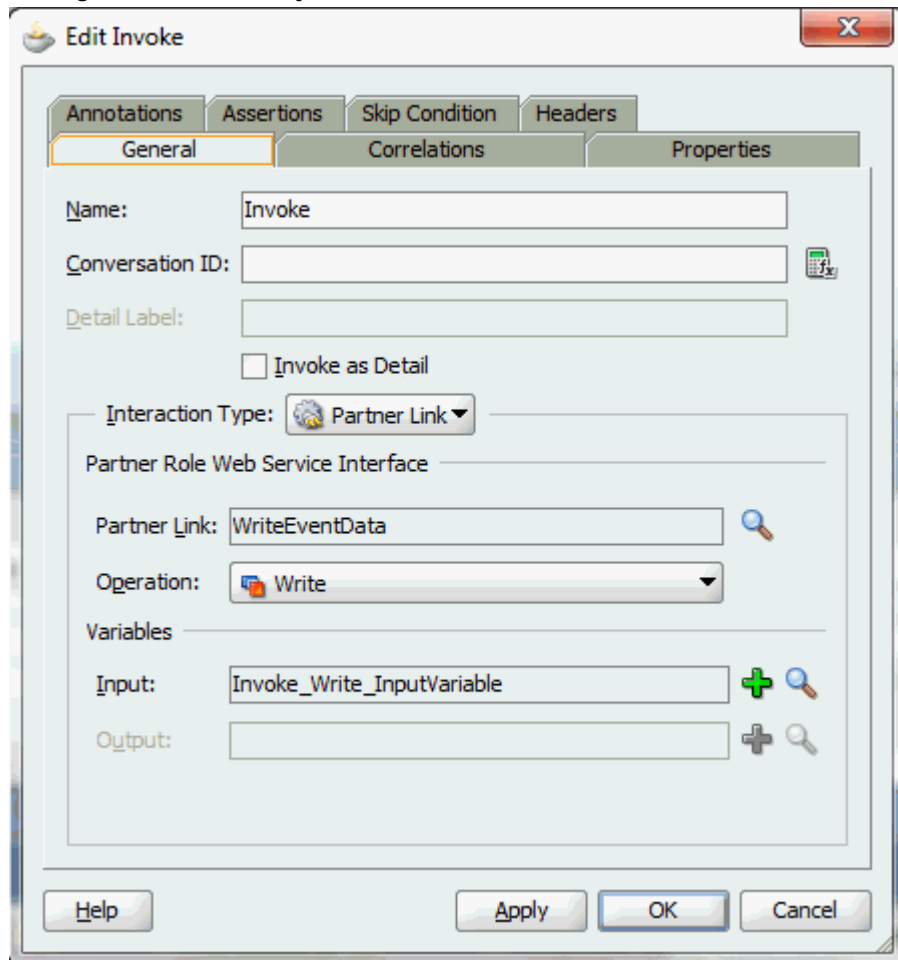

Click **Apply** and then **OK** to finish configuring the Invoke activity.

## Configuring an Assign Activity

Use the Assign activity to take the output from the Receive activity and to provide input to the invoke activity.

### To configure an Assign activity:

1. In Oracle JDeveloper BPEL Designer, expand the **BPEL Constructs** from the Component Palette. Drag and drop the **Assign** activity into the center swim lane of the process diagram, between the **Receive** activity and the **Invoke** activity.
2. Double-click the **Assign** activity to access the Edit Assign dialog.  
Click the General tab to enter a name for the Assign activity. For example,

setEventData.

3. Select the Copy Rules tab and expand the target trees:
  - In the From navigation tree, navigate to **Variable > Process > Variables > Receive\_DEQUEUE\_InputVariable** and select **WF\_EVENT\_T**.
  - In the To navigation tree, navigate to **Variable > Process > Variables > Invoke\_Write\_InputVariable > body > ns3:WF\_EVENT\_T**.

Drag the source node (WF\_EVENT\_T) to connect to the target node (body) that you just specified. This creates a line that connects the source and target nodes. The copy rule is displayed in the From and To sections at the bottom of the Edit Assign dialog box.

### Assigning Parameters

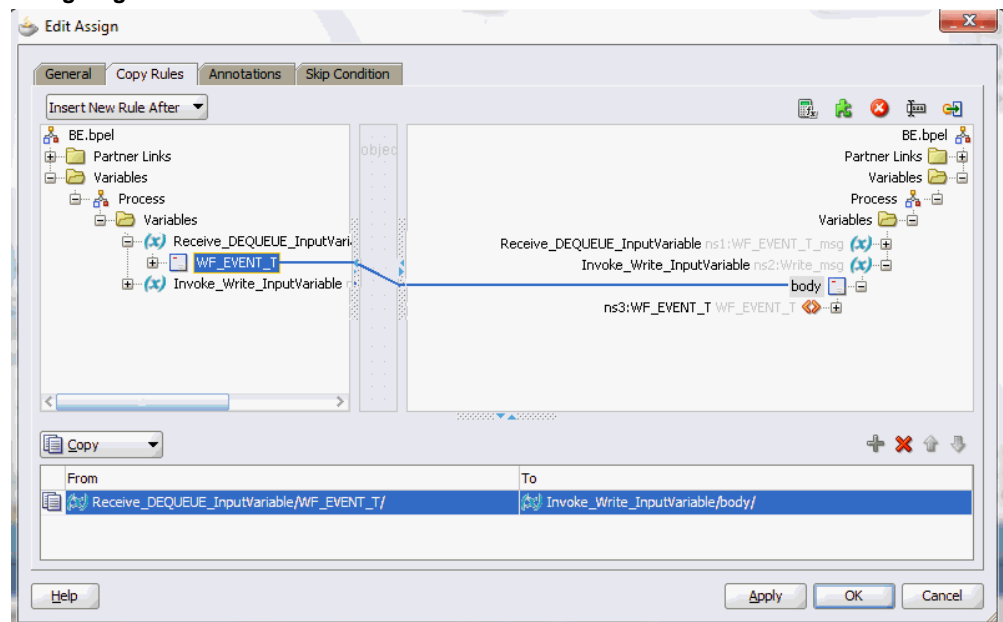

4. Click **Apply** and then **OK** in the Edit Assign dialog box to complete the configuration of the Assign activity.

### Completed Outbound Business Event BPEL Process Project

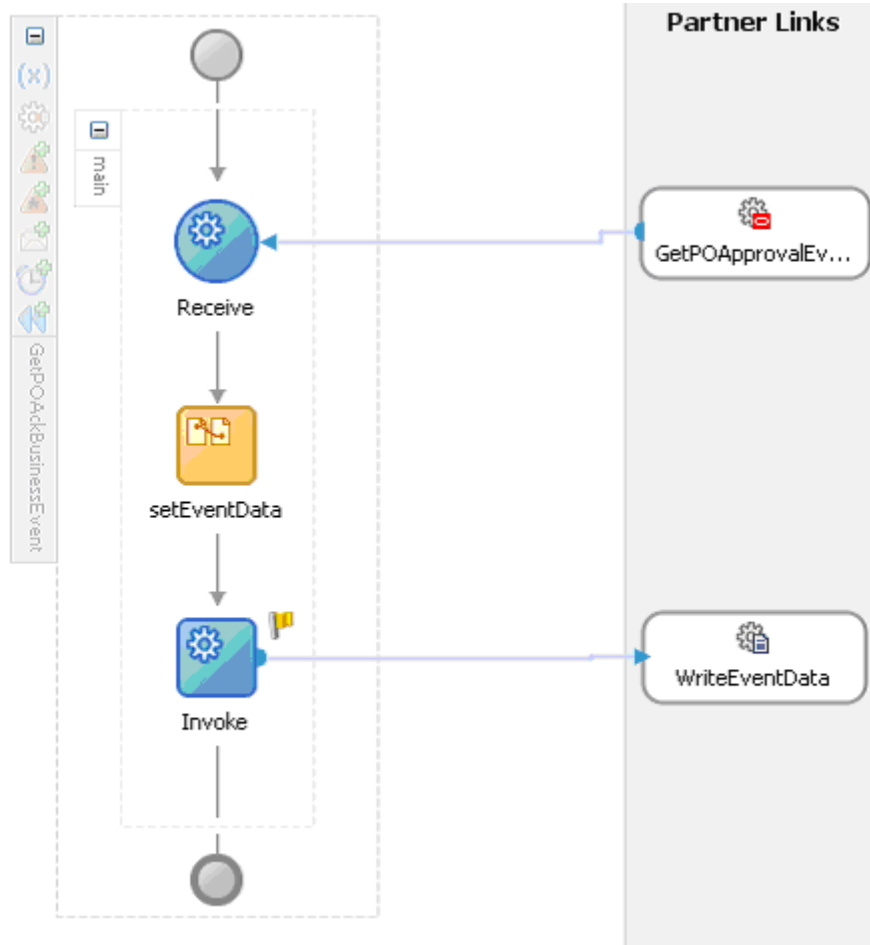

Click the `composite.xml` to display the Oracle JDeveloper composite diagram:

**Note:** Click the Source tab of `composite.xml` to enter a value for the physical directory `outputDir` for the reference `WriteEventData` (such as `/usr/tmp`).

```
<property name="outputDir" type="xs:string"
many="false" override="may">/usr/tmp</property>
```

## Specifying the Physical Directory for the Property

```
xmlns:oraclebp="http://schemas.oracle.com/ws/2007/01/property"
xmlns:ui="http://xmlns.oracle.com/soa/designer/"
namespace="http://xmlns.oracle.com/pcbpel/adapter/apps/GetPOAckBusinessEvent-App/ada
location="GetPOApprovalEvent.wsdl" importType="wsdl"/>
namespace="http://xmlns.oracle.com/pcbpel/adapter/file/GetPOAckBusinessEvent-App/ada
location="WriteEventData.wsdl" importType="wsdl"/>
e name="GetPOApprovalEvent" ui:wsdlLocation="GetPOApprovalEvent.wsdl">
rface.wsdl interface="http://xmlns.oracle.com/pcbpel/adapter/apps/GetPOAckBusinessEve
ing.jca config="GetPOApprovalEvent_apps.jca"/>
ce>
ent name="GetPOAckBusinessEvent">
ementation.bpel src="GetPOAckBusinessEvent.bpel"/>
erty name="activationAgent.GetPOApprovalEvent.className"
type="xs:string" many="false">oracle.tip.adapter.fw.agent.jca.JCAActivationAgent
erty name="activationAgent.GetPOApprovalEvent.portType"
type="xs:string" many="false">DEQUEUE_ptt</property>
ent>
nce name="WriteEventData" ui:wsdlLocation="WriteEventData.wsdl">
rface.wsdl interface="http://xmlns.oracle.com/pcbpel/adapter/file/GetPOAckBusinessEve
ing.jca config="WriteEventData_file.jca"/>
erty name="outputDir" type="xs:string" many="false" override="may"/>usc/tup</property>
ence>
ce.uri>GetPOApprovalEvent</source.uri>
et.uri>GetPOAckBusinessEvent/GetPOApprovalEvent</target.uri>
ce.uri>GetPOAckBusinessEvent/WriteEventData</source.uri>
et.uri>WriteEventData</target.uri>
te>
```

## Oracle JDeveloper Composite Diagram



## Run-Time Tasks for Outbound Business Events

After designing the SOA Composite with BPEL process, you can compile, deploy and test it.

1. Deploy the SOA Composite application with BPEL process, page 6-36.
2. Test the SOA Composite application with BPEL process, page 6-39.

## Deploying the SOA Composite Application with BPEL Process

To invoke the service (GetPOApprovalEvent) from the BPEL client contained in the SOA composite, the SOA composite needs to be deployed to the Oracle WebLogic managed server. This can be achieved using Oracle JDeveloper. Once the composite is deployed, it can be tested from the Oracle Enterprise Manager Fusion Middleware Control Console.

### Prerequisites

Before deploying the SOA composite with BPEL process using Oracle JDeveloper, you must have established the connectivity between the design-time environment and the run-time server. For more information, see *Configuring the Data Source in Oracle WebLogic Server*, page A-3 and *Creating an Application Server Connection*, page A-12.

**Note:** If a local instance of the WebLogic Server is used, start the WebLogic Server by selecting **Run > Start Server Instance** from Oracle JDeveloper. Once the WebLogic Admin Server "DefaultServer" instance is successfully started, the <Server started in Running mode> and DefaultServer started message in the Running:DefaultServer and Messages logs should appear.

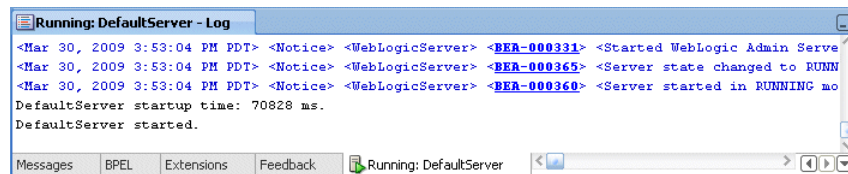

### To deploy the SOA Composite application with BPEL process:

1. In the Applications Navigator of JDeveloper BPEL Designer, select your SOA Composite project name (such as **GetPOAckBusinessEvent**).
2. Right-click the project name, and then select **Deploy > [project name] > [serverConnection]** from the menu that appears.

For example, you can select **Deploy > GetPOAckBusinessEvent > soa-server1** to deploy the process if you have the connection set up appropriately.

**Note:** If this is the first time to set up server connection, then the Deployment Action window appears. Select 'Deploy to Application Server' and click **Next**.

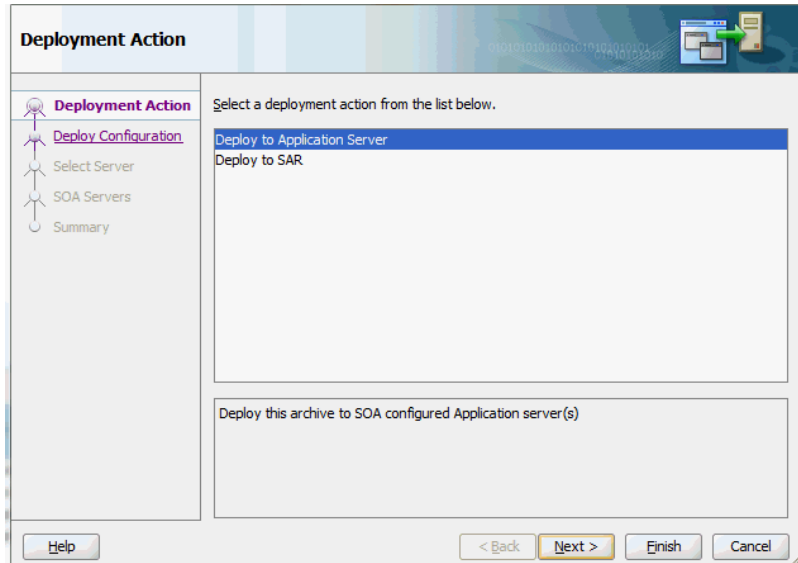

In the Deploy Configuration window, ensure the following information is selected before clicking **Next** to add a new application server:

- New Revision ID: 1.0
- Mark composite revision as default: Select this check box.
- Overwrite any existing composites with the same revision ID: Select this check box.

The steps to create a new Oracle WebLogic Server connection from JDeveloper are covered in [Creating an Application Server Connection](#), page A-12.

3. In the Select Server page, select 'soa-server1' that you have established the server connection earlier. Click **Next**.

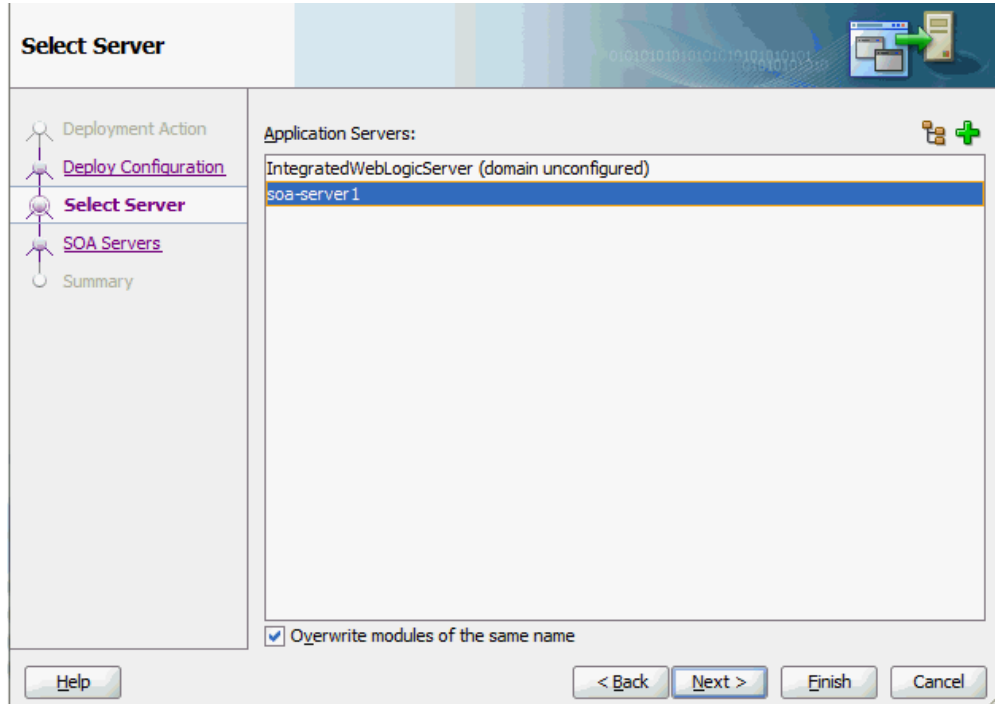

4. In the SOA Servers page, accept the default target SOA Server ('soa-server1') selection.



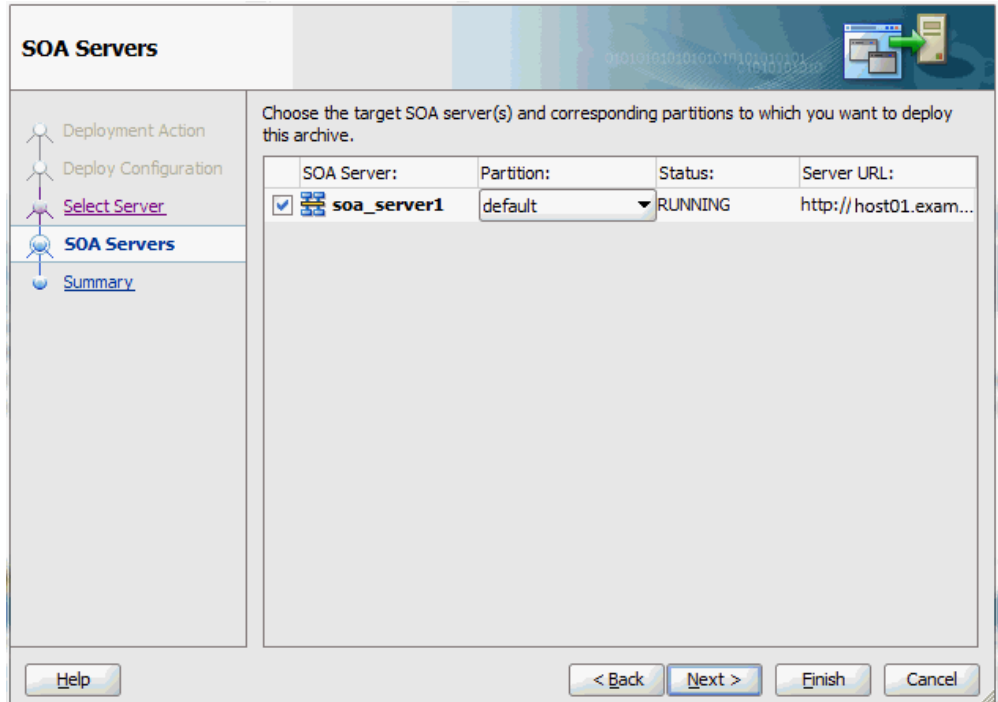

Click **Next** and **Finish**.

If you are deploying the composite for the first time from your Oracle JDeveloper session, the Authorization Request window appears. Enter username and password information specified during Oracle SOA Suite installation. Click **OK**.

5. Deployment processing starts. Monitor deployment progress and check for successful compilation in the SOA - Log window as well as in the Deployment - Log window.

## Testing the SOA Composite Application with BPEL Process

Once the SOA Composite application with BPEL process is deployed, you can manage and monitor the process from the Oracle Enterprise Manager Fusion Middleware Control Console. You can also test the process by manually initiating it.

### To test the SOA Composite application with BPEL process:

1. Navigate to Oracle Enterprise Manager Fusion Middleware Control Console (<http://<servername>:<portnumber>/em>). The composite you deployed is displayed in the Applications Navigation tree.

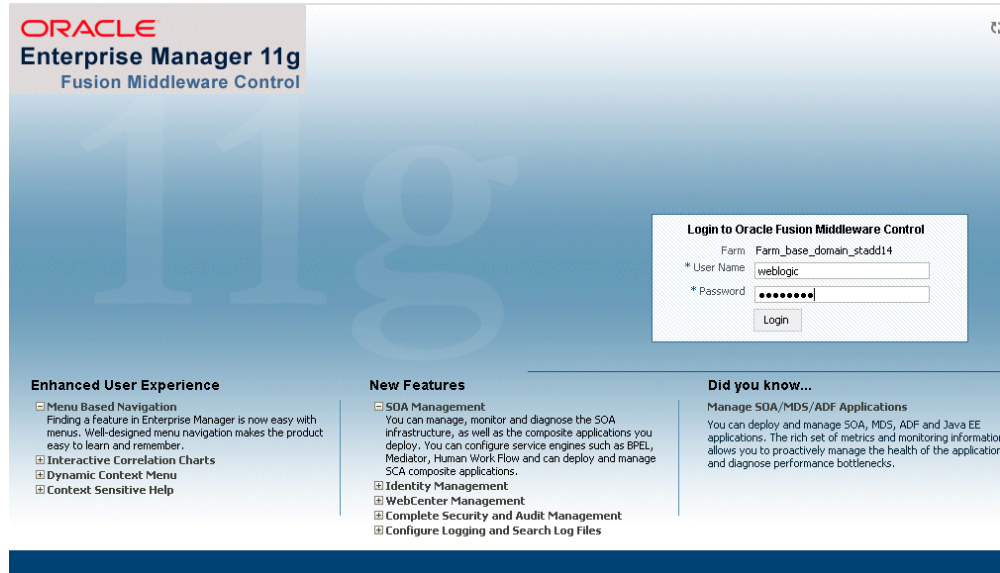

2. Enter username (such as `weblogic`) and password and click **Login** to log in to a farm.

You may need to select an appropriate target instance farm if there are multiple target Oracle Enterprise Manager Fusion Middleware Control Console farms.

3. From the Farm base domain, expand the **SOA >soa-infra** to navigate through the SOA Infrastructure home page and menu to access your deployed SOA Composite applications running in the SOA Infrastructure for that managed server.

**Note:** The Farm menu always displays at the top of the navigator. When you expand the SOA folder in the navigator and click the links displayed beneath it, the SOA Infrastructure menu becomes available at the top of the page.

4. Log on to Oracle Applications with the XML Gateway responsibility.

This is to ensure that the XML Gateway trading partner is set up correctly so that a purchase order can have a valid supplier that has been defined.

5. Select Define Trading Partner from the navigation menu to access the Trading Partner Setup window.
6. Enter the header values on the Trading Partner Setup form as follows:
  - Trading Partner Type: Supplier
  - Trading Partner Name: Advanced Network Devices

- Trading Partner Site: Enter a trading partner site information, such as 2000 Century Way, Santa Clara, CA 95613-4565.
  - Company Admin Email: Enter a valid e-mail address.
7. Enter the following trading partner details:
- Transaction Type: PO
  - Transaction SubType: PRO
  - Standard Code: OAG
  - External Transaction Type: PO
  - External Transaction SubType: Process
  - Direction: Out
  - Map: itg\_process\_po\_007\_out
  - Connection / Hub: DIRECT
  - Protocol Type: HTTP
  - Username: 'operation'
  - Password: Enter the associated password twice.
  - Protocol Address: 'http://appsadapter.sample.com'
  - Source Trading partner location code: STPLC

### Trading Partner Setup Form

Transaction Type	Transaction SubType	Standard Code	External Transaction Type	External Transaction SubType	Direction Map	Connection/Hub	Protocol Type	
PO	PRO	OAG	PO	PROCESS	OUT	itg_process_p	DIRECT	HTTP

Save the trading partner details.

8. Switch responsibility by selecting the Purchasing, Vision Operations (USA) and select Purchase Order from the navigation menu.

The Purchase Order forms is displayed.

9. Create a purchase order with the header values reflecting the trading partner you previously defined in the Purchase Order window:
  - Supplier: Enter a supplier information, such as 'Advanced Network Devices'.
  - Site: Select a site information, such as 'SANTA CLARA-ERS'.
10. On the Lines tab, enter a data row with the following values:
  - Type: Goods
  - Item: CM13139
  - Quantity: 1
  - Description: Hard Drive - 8GB

- Promised: Enter any future date in the format of dd-mmm-yyyy (such as 23-JUN-2009).
11. Save your purchase order. The status of the purchase order is 'Incomplete'.

**Setting Up a Purchase Order**

Oracle Applications - atgzdb2: Patch Test Env

Purchase Orders (Vision Operations) - (New)

PO, Rev: 4449    0    Type: Standard Purchase Order    Created: 19-JUL-2006 02:25:53

Supplier: Advanced Network Devices    Site: SANTA CLARA-ERS    Contact: [ ]

Ship-To: M1-Seattle    Bill-To: V1-New York City    Currency: USD    Total: 150.39 [ ]

Buyer: Stock, Ms. Pat    Status: Incomplete

Description: [ ]

P-Card: [ ]

Num	Type	Item	Rev	Category	Description	UOM	Quantity	Price	Promised
1	Goods	CM13139		PRODUCTN.DRN	Hard Drive - 8GB	Each	1	150.393	20-JUL-2007 00:00

Item: CM13139    Hard Drive - 8GB

Buttons: Catalog...    Currency...    Terms    Shipments    Approve...

12. Click **Approve**. The Approve Document form appears.

## Approving the Purchase Order

Click **OK** to confirm the approval.

**Note:** Because the trading partner is set up and valid, the transmission method is automatically set to **XML**.

The status of the purchase order is now changed to 'Approved'. For future reference, record the value of the PO, Rev field (for example, the PO number 4449 in this case).

Once the purchase order is approved, the business event `oracle.apps.po.event.xmlpo` is raised.

13. Use the following steps to ensure that the **WF\_Deferred Agent Listener** is running on the target database.
  1. Log on to Oracle E-Business Suite with the System Administrator responsibility.
  2. Select the Workflow Administrator Web Applications responsibility and choose **Oracle Applications Manager > Workflow Manager** from the menu.

## Managing Oracle Applications

Oracle Workflow Manager - System Status - Microsoft Internet Explorer

Address: [http://qapache.us.oracle.com:8482/oa\\_servlets/web/oaam/cam/wfm/sysStatus?target=atgzdb2](http://qapache.us.oracle.com:8482/oa_servlets/web/oaam/cam/wfm/sysStatus?target=atgzdb2)

ORACLE Applications Manager

Applications Dashboard | Site Map

Applications System: atgzdb2

Last Updated: 19-07-2006 02:50:16

Notification Mailers Up  
Agent Listeners Up  
Service Components Up

Background Engines Up  
Purge Up  
Control Queue Cleanup Up

Submit Request For: Background Engines [Go]

Related Database Parameters

Last Updated: 19-07-2006 02:50:16

Parameter Name	Parameter Value	Recommended Value	Description
job_queue_processes	2	10	number of job queue slave processes
aq_tm_processes	1	>= 1	number of AQ Time Managers to start

Workflow Metrics

Work Items Agent Activity

Related Links

Configuration | Throughput  
Service Components | Work Items  
Queue Propagation | Agent Activity  
Notification Mailers

Copyright 2001, 2005 Oracle Corporation. All Rights Reserved.  
About Oracle Applications Manager, Version 7.3.1

Support Cart | Setup | Home | Logout | Help

Add to Support Cart

3. On the Applications Manager page, click the **Agent Listeners** icon. The Service Components page appears, containing a list of the installed agent listeners.

## Reviewing Agent Listener status

The screenshot shows the Oracle Applications Dashboard for 'atg121d4'. The 'Service Components' section is active, displaying a list of agent listeners. The 'Workflow Deferred Agent Listener' is highlighted in blue, indicating it is the selected component. The table below shows the status of several other listeners, all of which are in a 'Running' state.

Select Name	Status	Type	Startup Mode	Container Type	Container	Actions
<input checked="" type="radio"/> ECX Inbound Agent Listener	Running	Workflow Agent Listener	Automatic	Oracle Applications GSM	Workflow Agent Listener Service	Refresh
<input type="radio"/> ECX Transaction Agent Listener	Running	Workflow Agent Listener	Automatic	Oracle Applications GSM	Workflow Agent Listener Service	Refresh
<input type="radio"/> WF_JMS_IN Listener(MHU)	Running	Workflow Java Agent Listener	Automatic	Oracle Applications GSM	Workflow Agent Listener Service	Refresh
<input type="radio"/> Web Services IN Agent	Running	Workflow Java Agent Listener	Automatic	Oracle Applications GSM	Workflow Agent Listener Service	Refresh
<input type="radio"/> Workflow Deferred Agent Listener	Running	Workflow Agent Listener	Automatic	Oracle Applications GSM	Workflow Agent Listener Service	Refresh
<input type="radio"/> Workflow Deferred Notification Agent Listener	Running	Workflow Agent Listener	Automatic	Oracle Applications GSM	Workflow Agent Listener Service	Refresh
<input type="radio"/> Workflow Error Agent Listener	Running	Workflow Agent Listener	Automatic	Oracle Applications GSM	Workflow Agent Listener Service	Refresh
<input type="radio"/> Workflow Inbound JMS Agent Listener	Running	Workflow Agent Listener	Automatic	Oracle Applications GSM	Workflow Agent Listener Service	Refresh
<input type="radio"/> Workflow Inbound Notifications Agent Listener	Running	Workflow Agent Listener	Automatic	Oracle Applications GSM	Workflow Agent Listener Service	Refresh
<input type="radio"/> Workflow Java Deferred Agent Listener	Running	Workflow Java Agent Listener	Automatic	Oracle Applications GSM	Workflow Agent Listener Service	Refresh
<input type="radio"/> Workflow Java Error Agent Listener	Running	Workflow Java Agent Listener	Automatic	Oracle Applications GSM	Workflow Agent Listener Service	Refresh

4. Confirm that the **Workflow Deferred Agent Listener** is in Running status.

14. At this time, your deployed BPEL process contained in a SOA Composite is listening for `oracle.apps.po.event.xmlpo` business event. Please allow 2 to 3 minutes for the BPEL process to activate after the event is raised.
15. Go to the directory, for example `outputDir` (typically under `c:\temp`) you specified for the write operation. Open the output file (such as `EventAck%yyMMddHHmmss.xml`), and confirm that the order number is same as that of the approved purchase order.



## Confirming the Output Order Number

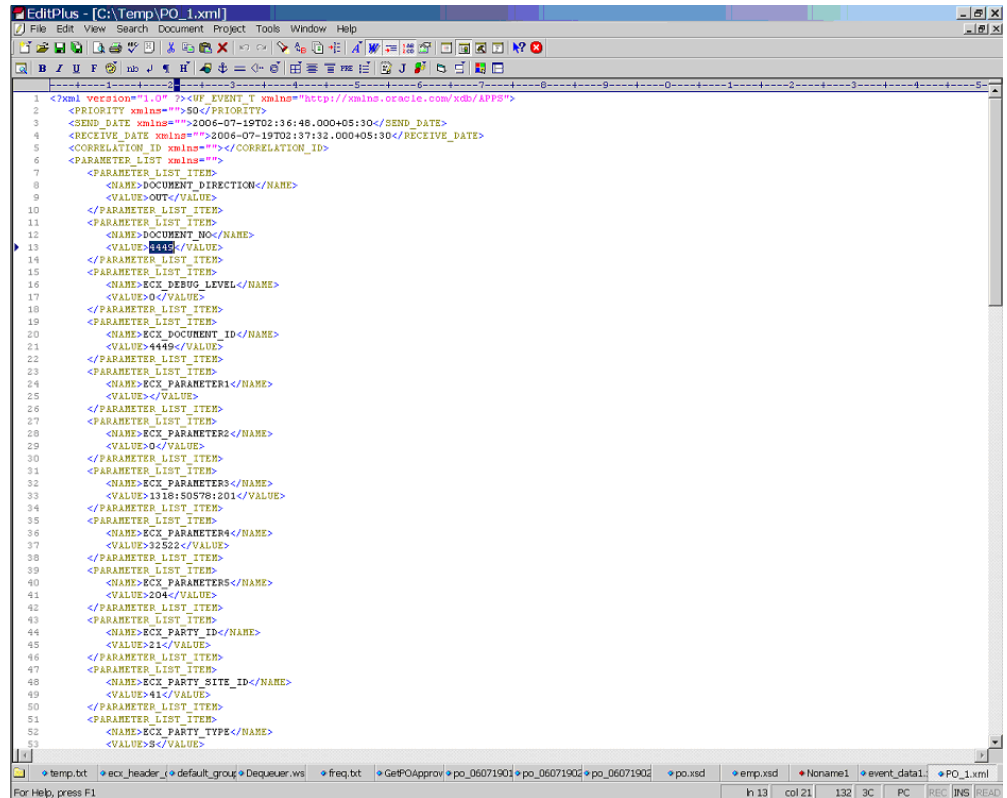

```
1 <?xml version="1.0" ?><UP_EVENT xmlns="http://xmlns.oracle.com/sdb/APP" >
2 <PRIORITY xmlns="">50</PRIORITY>
3 <SEND_DATE xmlns="">2006-07-19T02:36:48.000+05:30</SEND_DATE>
4 <RECEIVE_DATE xmlns="">2006-07-19T02:37:32.000+05:30</RECEIVE_DATE>
5 <CORRELATION_ID xmlns=""></CORRELATION_ID>
6 <PARAMETER_LIST xmlns="">
7 <PARAMETER_LIST_ITEM>
8 <NAME>DOCUMENT_DIRECTION</NAME>
9 <VALUE>OUT</VALUE>
10 </PARAMETER_LIST_ITEM>
11 <PARAMETER_LIST_ITEM>
12 <NAME>DOCUMENT_NO</NAME>
13 <VALUE>449</VALUE>
14 </PARAMETER_LIST_ITEM>
15 <PARAMETER_LIST_ITEM>
16 <NAME>ECX_DEBUG_LEVEL</NAME>
17 <VALUE>0</VALUE>
18 </PARAMETER_LIST_ITEM>
19 <PARAMETER_LIST_ITEM>
20 <NAME>ECX_DOCUMENT_ID</NAME>
21 <VALUE>449</VALUE>
22 </PARAMETER_LIST_ITEM>
23 <PARAMETER_LIST_ITEM>
24 <NAME>ECX_PARAMETER1</NAME>
25 <VALUE></VALUE>
26 </PARAMETER_LIST_ITEM>
27 <PARAMETER_LIST_ITEM>
28 <NAME>ECX_PARAMETER2</NAME>
29 <VALUE>0</VALUE>
30 </PARAMETER_LIST_ITEM>
31 <PARAMETER_LIST_ITEM>
32 <NAME>ECX_PARAMETERS3</NAME>
33 <VALUE>1318:50578:201</VALUE>
34 </PARAMETER_LIST_ITEM>
35 <PARAMETER_LIST_ITEM>
36 <NAME>ECX_PARAMETERS4</NAME>
37 <VALUE>32522</VALUE>
38 </PARAMETER_LIST_ITEM>
39 <PARAMETER_LIST_ITEM>
40 <NAME>ECX_PARAMETERS5</NAME>
41 <VALUE>204</VALUE>
42 </PARAMETER_LIST_ITEM>
43 <PARAMETER_LIST_ITEM>
44 <NAME>ECX_PARTY_ID</NAME>
45 <VALUE>2</VALUE>
46 </PARAMETER_LIST_ITEM>
47 <PARAMETER_LIST_ITEM>
48 <NAME>ECX_PARTY_SITE_ID</NAME>
49 <VALUE>41</VALUE>
50 </PARAMETER_LIST_ITEM>
51 <PARAMETER_LIST_ITEM>
52 <NAME>ECX_PARTY_TYPE</NAME>
53 <VALUE>S</VALUE>

```

## Troubleshooting

If you experience problems with your Business Event System integration, you can check the following troubleshooting steps:

- Confirm that Workflow Deferred Agent Listener is up and running.
- Ensure that business events are raised after the Composite is deployed.
- If the partner link of Adapter for Oracle Applications is created on one instance of Oracle Applications and deployed on another, ensure the following on the target database:
  - WF\_BPEL\_Q queue exists
  - A custom subscription for the business event being raised is present

**Note:** The above two can be easily recreated by running the  
XX\_BPEL\_WFEVENT\_<parnerlink\_name>.sql (located in the

project folder) on the target Oracle Applications database.

- Enable logging for Adapter to see if the issue is on the middleware side. How to enable logging for Adapter for Oracle Applications, see [Enabling Logging for Adapters](#), page 4-82.

---

## Using Concurrent Programs

This chapter covers the following topics:

- Overview of Concurrent Programs
- Design-Time Tasks for Concurrent Programs
- Creating a New SOA Composite Application with BPEL Project
- Adding Partner Links
- Adding Partner Links for File Adapter
- Configuring Invoke Activities
- Configuring Assign Activities
- Run-Time Tasks for Concurrent Programs
- Deploying the SOA Composite Application with BPEL Process
- Testing the Deployed SOA Composite Application with BPEL Process
- Verifying Records in Oracle E-Business Suite
- Troubleshooting

### Overview of Concurrent Programs

A concurrent program is an instance of an execution file. Concurrent programs use a concurrent program executable to locate the correct execution file. Several concurrent programs may use the same execution file to perform their specific tasks, each having different parameter defaults. Concurrent manager runs in the background waiting for a concurrent program to be submitted. As soon as a concurrent program is submitted, it is put into an execution queue by concurrent manager. Concurrent manager also manages the concurrent execution of concurrent programs.

Concurrent programs associated with the Open Interface Table move the data from interface table to base tables. While other concurrent programs execute the business logic and application-level processing for Oracle E-Business Suite.

## Accessing Concurrent Programs

Use Oracle Applications Module Browser to access concurrent programs either by browsing through product family or by performing a search to locate your desired concurrent programs.

### *Custom Concurrent programs*

For custom concurrent programs, they are displayed in the Oracle Applications Module Browser under the **Other Interfaces > Custom Objects > Concurrent Programs** node.

### **Browsing and Selecting a Custom Concurrent Program**

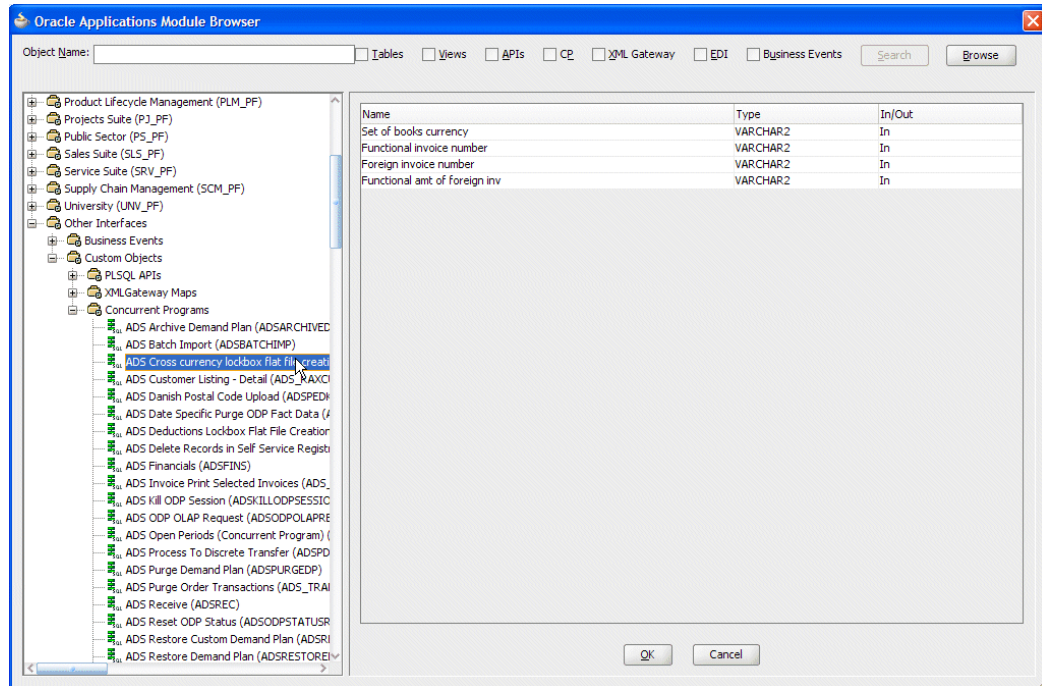

Alternatively, you can perform a search to locate your desired custom concurrent programs.

## Searching for a Custom Concurrent Program

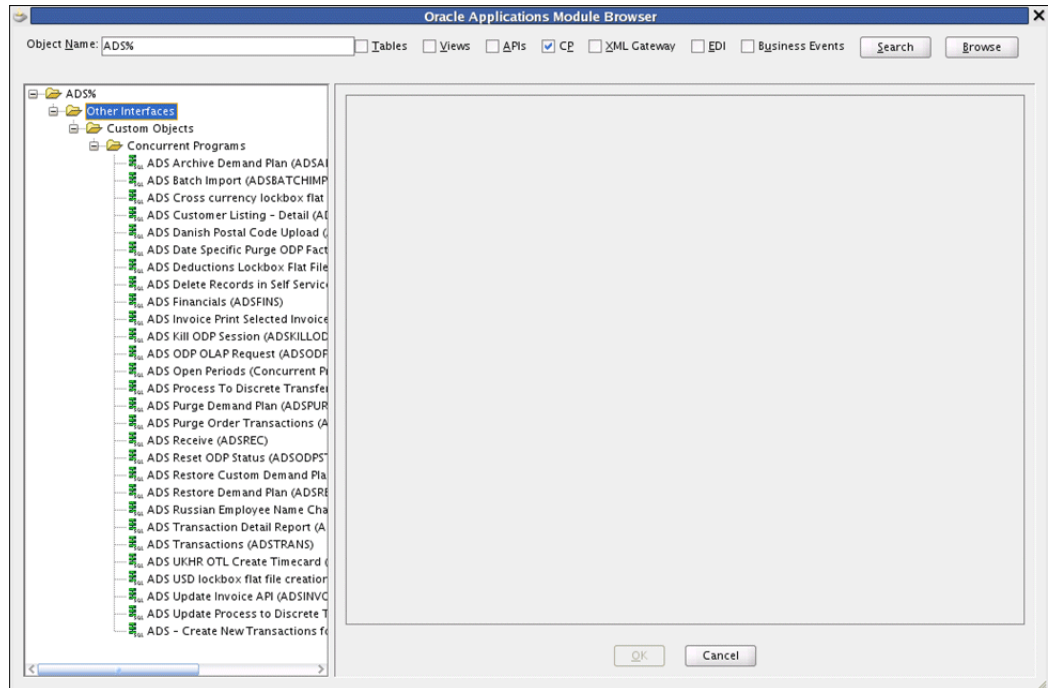

## Design-Time Tasks for Concurrent Programs

This section describes how to configure the Adapter for Oracle Applications to use concurrent programs. It describes the tasks required to configure Adapter for Oracle Applications using the Adapter Configuration Wizard in Oracle JDeveloper.

### SOA Composite Application with BPEL Process Scenario

Take Open Interface: Order Import concurrent program (OE\_OIMP) as an example. This concurrent program allows you to run the Order Import process to retrieve order details from the Order Management open interface tables to create sales orders.

When a request of creating an order is received, order details will be passed and inserted into Open Interface tables (OE\_HEADER\_IFACE\_ALL and OE\_LINES\_IFACE\_ALL). Once the insertion is completed, the concurrent program is invoked to import order data from Open Interface tables to Order Management base tables.

When the SOA Composite application with BPEL process has been successfully executed after deployment, you should find the order is created in Oracle Applications. The purchase order ID should be the same as the payload input value.

### Prerequisites to Configuring Concurrent Programs

#### *Populating Applications Context Header Variables*

You need to populate certain variables in the BPEL PM in order to provide context information for Oracle Applications. The context information is required for a transaction in order for an Oracle Applications user that has sufficient privileges to run the program.

The context is set taking into account the values passed for the header properties including *Username*, *Responsibility*, *Responsibility Application*, *Security Group*, and *NLS Language*. If the values for the new header properties *Responsibility Application*, *Security Group*, and *NLS Language* are not passed, context information will be determined based on *Username* and *Responsibility*.

The default Username is SYSADMIN, the default Responsibility is SYSTEM ADMINISTRATOR, the default Security Group Key is Standard, and the default NLS Language is US.

You can change the default values specified in the generated WSDL. This is a static way of changing the context information. These values would apply to all invocations of the deployed business process. However, if you need to provide different context information for different invocations of the business process, then you can dynamically populate the header values. The context information can be specified by configuring an Invoke activity.

For more information about applications context, see Supporting for Normalized Message Properties, page 4-7.

### **SOA Composite Application with BPEL Process Creation Flow**

Based on the process scenario, the following design-time tasks are explained in this chapter:

1. Create a new SOA Composite application with BPEL process, page 7-4
2. Add partner links, page 7-9
3. Add a partner link for File Adapter, page 7-31
4. Configure Invoke activities, page 7-42
5. Configure Assign activities, page 7-49

## **Creating a New SOA Composite Application with BPEL Project**

### **To create a new SOA Composite application with BPEL project:**

1. Open JDeveloper BPEL Designer. Click **New Application** in the Application Navigator.

The Create SOA Application - Name your application page is displayed.

## The Create SOA Application - Name your application Page

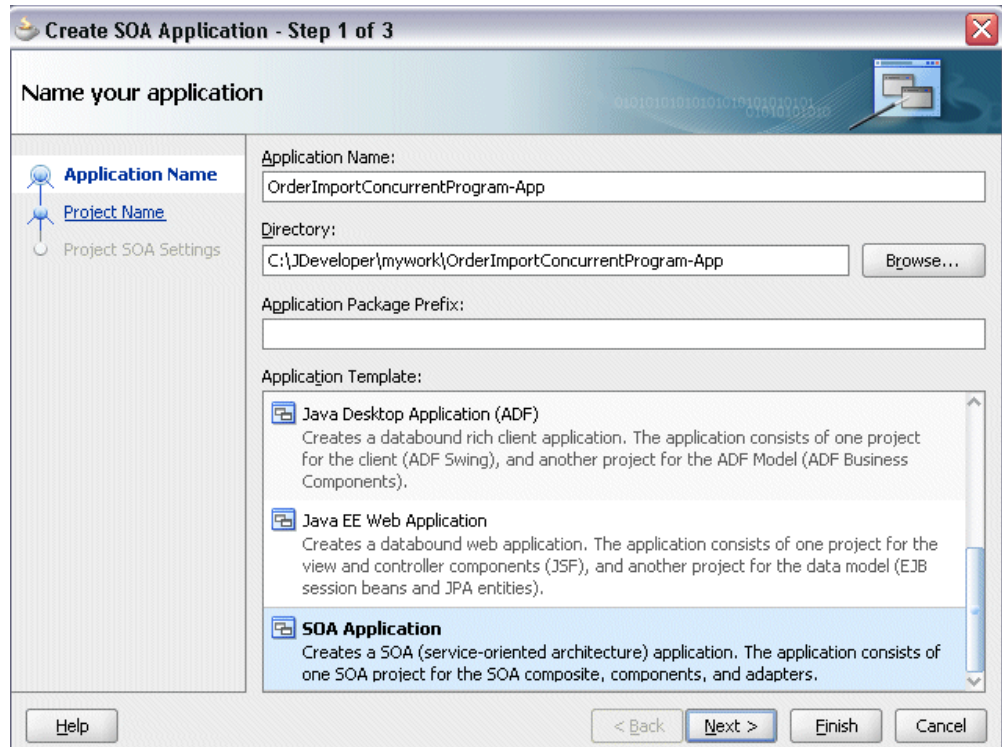

2. Enter an appropriate name for the application in the **Application Name** field and select **SOA Application** from the Application Template list.

Click **Next**. The Create SOA Application - Name your project page is displayed.

3. Enter an appropriate name for the project in the **Project Name** field. For example, `OrderImportConcurrentProgram`.

### The Create SOA Application - Name your project Page

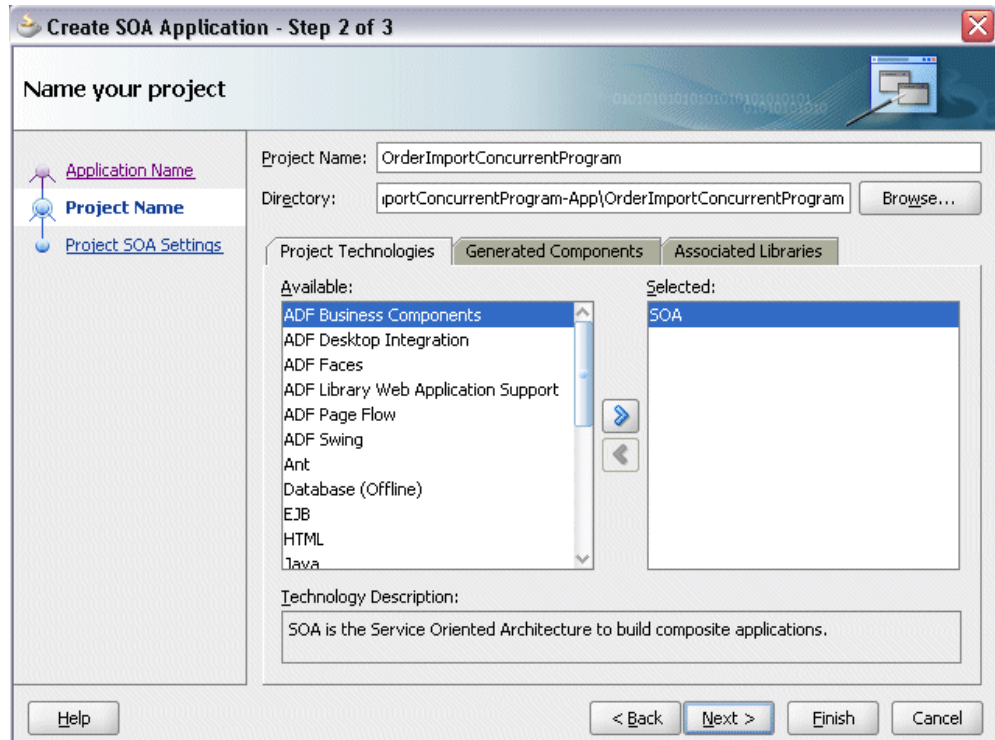

4. In the Project Technologies tab, ensure that **SOA** is selected from the Available technology list to the Selected technology list.

Click **Next**. The Create SOA Application - Configure SOA settings page is displayed.



### The Create SOA Application - Configure SOA settings Page

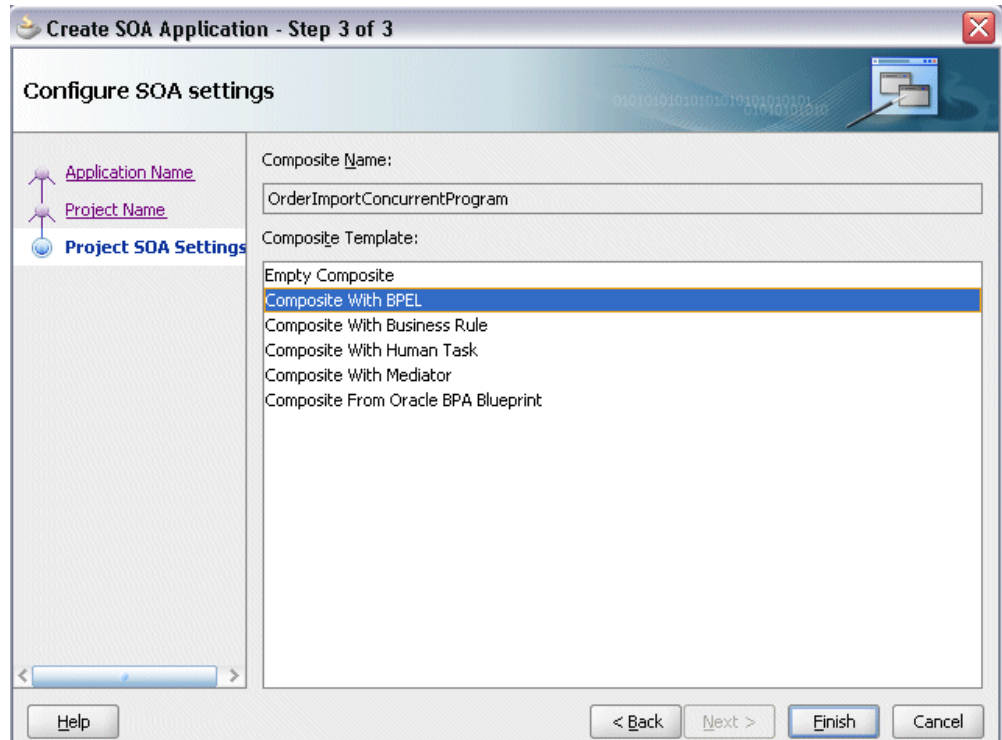

5. In the **BPEL Process Name** field, enter a descriptive name. For example, OrderImportConcurrentProgram.
6. Select **Composite With BPEL** from the Composite Template list, and then click **Finish**. You have created a new application, and a SOA project. This automatically creates a SOA Composite.

The Create BPEL Process page is displayed.

### The Create BPEL Process Page

**BPEL Process**

A BPEL process is a service orchestration, based on the BPEL specification, used to describe/execute a business process (or large grained service), which is implemented as a stateful service.

BPEL 1.1 Specification  BPEL 2.0 Specification

Name:

Namespace:

Template:

Service Name:

Expose as a SOAP service

Delivery:

Input:

Output:

Help OK Cancel

7. Leave the default **BPEL 1.1 Specification** selection unchanged. This creates a BPEL project that supports the BPEL 1.1 specification.

Enter an appropriate name for the BPEL process in the **Name** field. For example, `OrderImportConcurrentProgram`.

Select **Asynchronous BPEL Process** in the **Template** field. Click **OK**.

An asynchronous BPEL process is created with the Receive and Reply activities. The required source files including `bpel` and `wSDL`, using the name you specified (for example, `OrderImportConcurrentProgram.bpel` and `OrderImportConcurrentProgram.wSDL`) and `composite.xml` are also generated.

8. Navigate to SOA Content > Business Rules and click `composite.xml` to view the composite diagram.

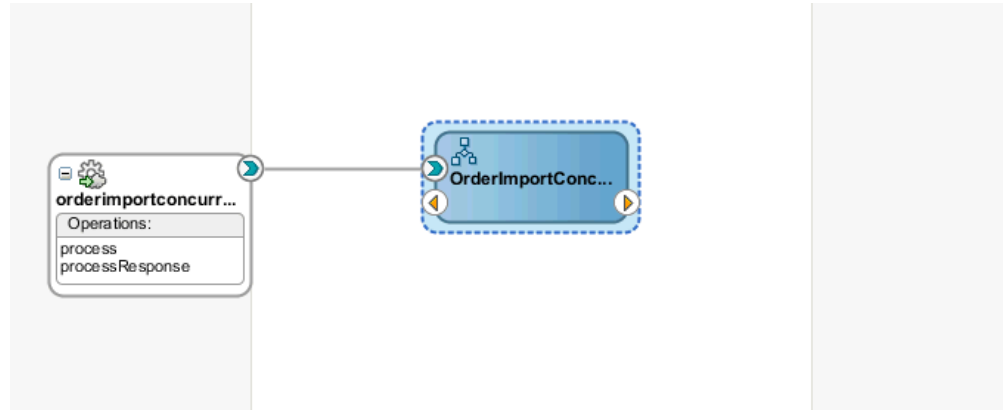

Double click on the `OrderImportConcurrentProgram` component to open the BPEL process.

## Adding Partner Links

The next task is to add a partner link to the BPEL process. A partner link defines the link name, type, and the role of the BPEL process that interacts with the partner service.

Based on the BPEL process scenario discussed earlier, the following two partner links need to be configured:

- Add the first partner link `InsertOrder` to insert order details into selected Open Interface tables
- Add the second partner link `ImportOrderCP` to import purchase order data from the Open Interface tables to Order Management base tables

### To add the first partner link:

1. Click **BPEL Services** in the Component palette.

Drag and drop **Oracle Applications** from the **BPEL Services** list into the right Partner Link swim lane of the process diagram. The Adapter Configuration Wizard Welcome page appears. Click **Next**.

2. Enter a service name in the **Service Name** field. For example, `InsertOrder`. Click **Next**. The Service Connection dialog appears.

### Specifying a Database Service Connection

Adapter Configuration Wizard - Step 3 of 4

#### Service Connection

A Database Connection is required to configure this adapter. Select a database connection already defined in your project or create a New Connection.

Connection: OracleAppsConnection

User Name: apps

Driver: oracle.jdbc.OracleDriver

Connect String: jdbc:oracle:thin:@localhost:1521:sid01

Specify the JNDI name for the database. Note: The deployment descriptor of the Oracle Applications adapter must associate this JNDI name with configuration properties required by the adapter to access the database.

JNDI Name: eis/Apps/OracleAppsConnection

Help < Back Next > Finish Cancel

3. You can perform either one of the following options for your database connection:

**Note:** You need to connect to the database where Oracle Applications is running.

- You can create a new database connection by clicking the **Create a New Database Connection** icon.

How to define a new database connection, see *Create a New Database Connection*, page 5-13.

- You can select an existing database connection that you have configured earlier from the **Connection** drop-down list.

The Service Connection page will be displayed with the selected connection information. The JNDI (Java Naming and Directory Interface) name corresponding to the database connection appears automatically in the **Database Server JNDI Name** field. Alternatively, you can specify a JNDI name.

**Note:** When you specify a JNDI name, the deployment descriptor of the Oracle Applications adapter must associate this JNDI name with configuration properties required by the adapter to access the database.

The JNDI name acts as a placeholder for the connection used when your service is deployed to the BPEL server. This enables you to use different databases for development and later for production.

**Note:** For more information about JNDI concepts, refer to *Oracle Fusion Middleware User's Guide for Technology Adapters*.

4. Click **Next** in the Service Connection dialog box. You can add a concurrent program by browsing through the list of concurrent programs available in Oracle Applications.

**For Oracle E-Business Suite Release 12:**

If you are connecting to Oracle E-Business Suite Release 12, then the **IREP File not present** dialog box appears indicating that Adapter could not find the Oracle Integration Repository data file corresponding to the database you are connecting in your workspace. Absence of the data file would make browsing or searching of Integration Repository tree considerably slow. You can choose to extract the data file and create a local copy of the Integration Repository data file. Once it is created successfully, Adapter will pick it up automatically next time and retrieve data from your local Integration Repository.

You can select one of the following options:

- Click **Yes** to extract the Integration Repository data file.

### Extracting Integration Repository Data File

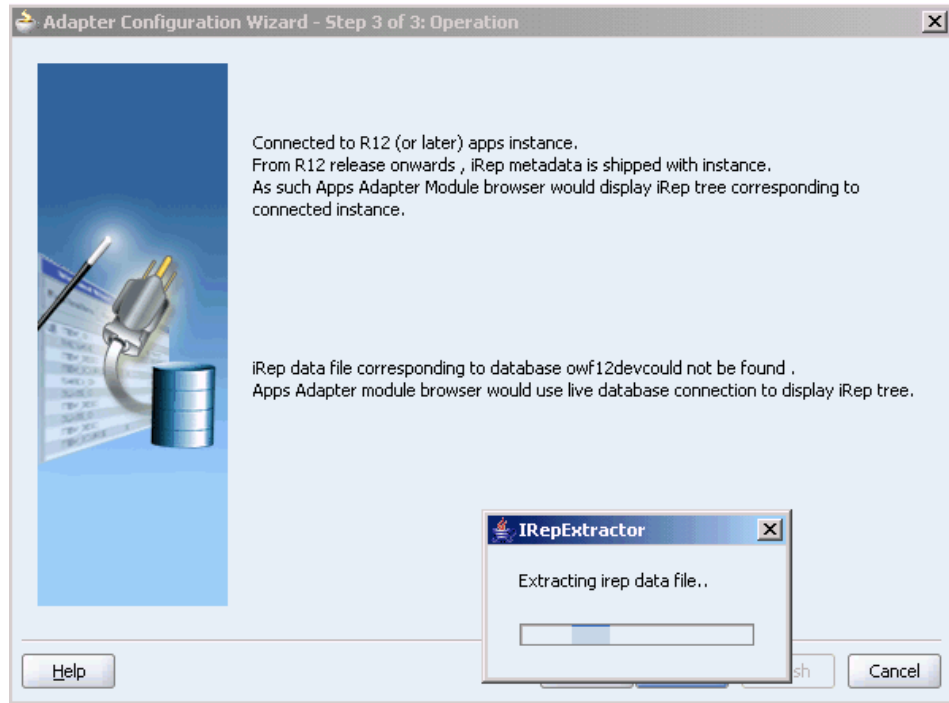

After the system successfully creates a local copy of the Integration Repository data file, next time when you connect to the database, you will find the **IRep Data File** field appears in the Operation dialog box indicating where your local copy exists with the creation date and time as part of the file name.

### Using the Local Integration Repository Data File

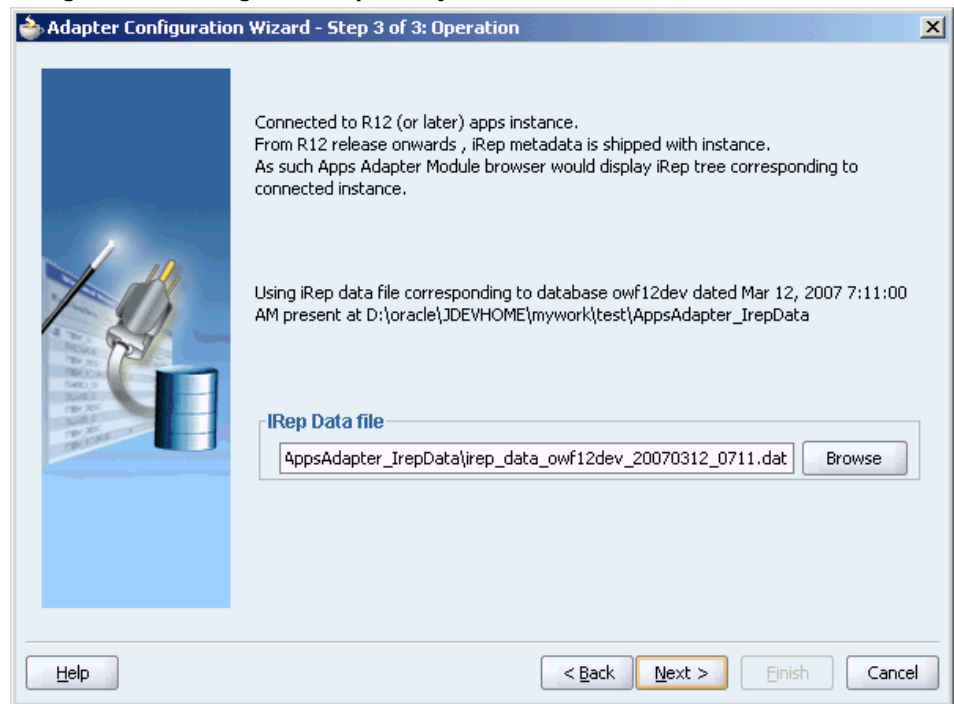

- Click **No** to query the Integration Repository data file from the live database you are connecting to display the Integration Repository tree.

#### **For Oracle E-Business Suite Release 11.5.9:**

If you are connecting to an Oracle E-Business Suite Release 11.5.9 instance, you must select the interface type in the Adapter Configuration Wizard. Select **Tables/Views/APIs/Concurrent Programs** to proceed.

5. Click **Get Object** to open the Oracle Applications Module Browser.

## Selecting a Concurrent Program from the Module Browser

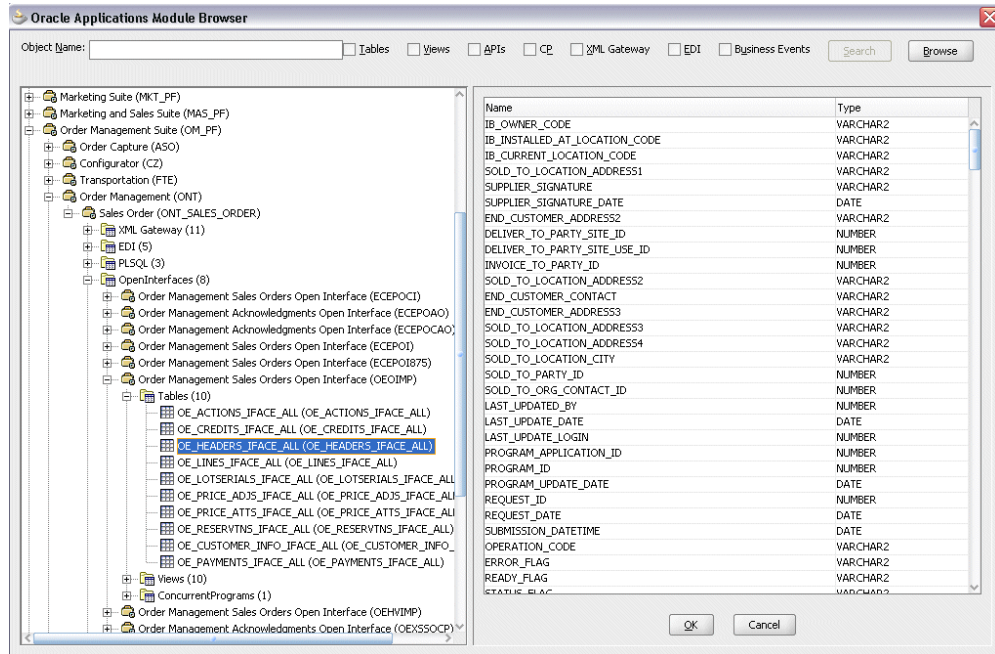

Oracle Applications Module Browser includes the various product families that are available in Oracle Applications. For example, Applications Technology or Order Management Suite are product families in Oracle Applications. The product families contain the individual products. For example, Order Management Suite contains the Order Management product. The individual products contain the business entities associated with the product. For example, the Order Management product contains the Sales Order business entity.

Business entities contain the various application modules that are exposed for integration. These modules are grouped according to the interface they provide. concurrent programs can be found under the Open Interfaces category.

6. Navigate to *Order Management Suite (OM\_PF) > Order Management (ONT) > Sales Order (ONT\_SALES\_ORDER) > OpenInterfaces > Order Management Sales Orders Open Interface (OEOIMP) > Tables* to select `OE_HEADERS_IFACE_ALL`.

Click **OK**. The Application Interface page appears with the selected open table.



### Adapter Configuration Wizard - Application Interface Page

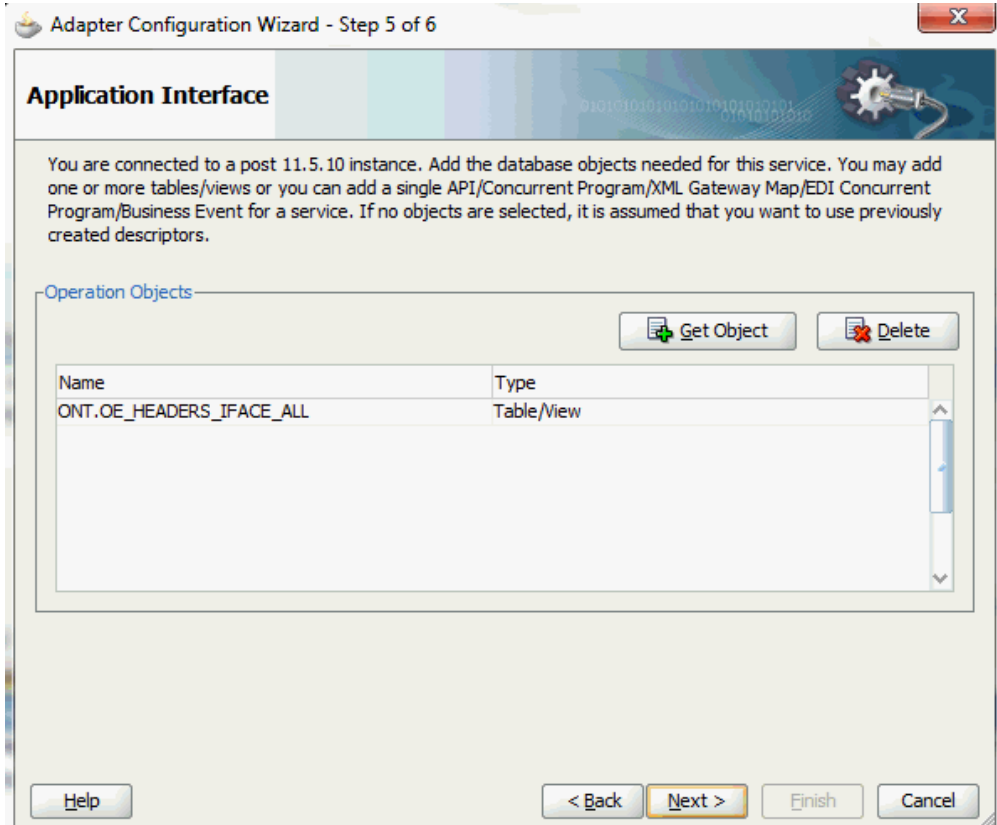

7. Click **Get Object** to open the Oracle Applications Module Browser again to select another open interface table `OE_LINES_IFACE_ALL` using the same navigation path *Order Management Suite (OM\_PF) > Order Management (ONT) > Sales Order (ONT\_SALES\_ORDER) > OpenInterfaces > Order Management Sales Orders Open Interface (OEOIMP) > Tables*.

Click **OK**. The Application Interface page appears with the two selected tables.

## Adapter Configuration Wizard - Application Interface Page

Adapter Configuration Wizard - Step 5 of 6

### Application Interface

You are connected to a post 11.5.10 instance. Add the database objects needed for this service. You may add one or more tables/views or you can add a single API/Concurrent Program/XML Gateway Map/EDI Concurrent Program/Business Event for a service. If no objects are selected, it is assumed that you want to use previously created descriptors.

Operation Objects

Name	Type
ONT.OE_HEADERS_IFACE_ALL	Table/View
ONT.OE_LINES_IFACE_ALL	Table/View

Click **OK**.

8. Click **Next**. The Operation Type page is displayed.

### Adapter Configuration Wizard - Operation Type Page

Adapter Configuration Wizard - Step 6 of 7

## Operation Type

Select the Operation Type and click Next to continue defining the operation.

Operation Type:  Perform an Operation on a Table

- Insert
- Select
- Select By Primary Key

Poll for New or Changed Records in a Table

Do Synchronous Post to BPEL (Allows In-Order Delivery)

Cache Usage: none (default) ▼

Help < Back Next > Finish Cancel

Select the **Perform an Operation on a Table** radio button and then choose the **Insert** check box. Ensure that the **Select** check box is deselected.

9. Click **Next**. The Select Table page is displayed.

### Adapter Configuration Wizard - Select Table Page

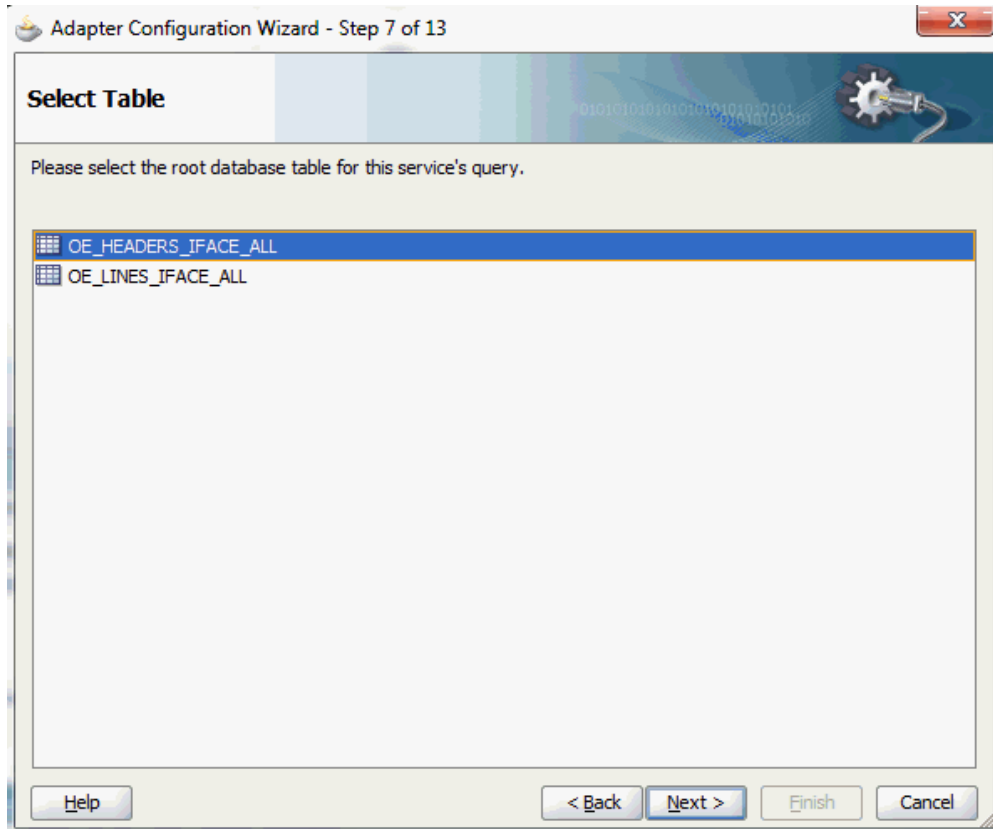

Select OE\_HEADERS\_IFACE\_ALL as the root database table for this service's query.

10. Click Next. The Define Primary Keys page is displayed.

**Adapter Configuration Wizard - Define Primary Keys Page for  
OE\_HEADERS\_IFACE\_ALL**

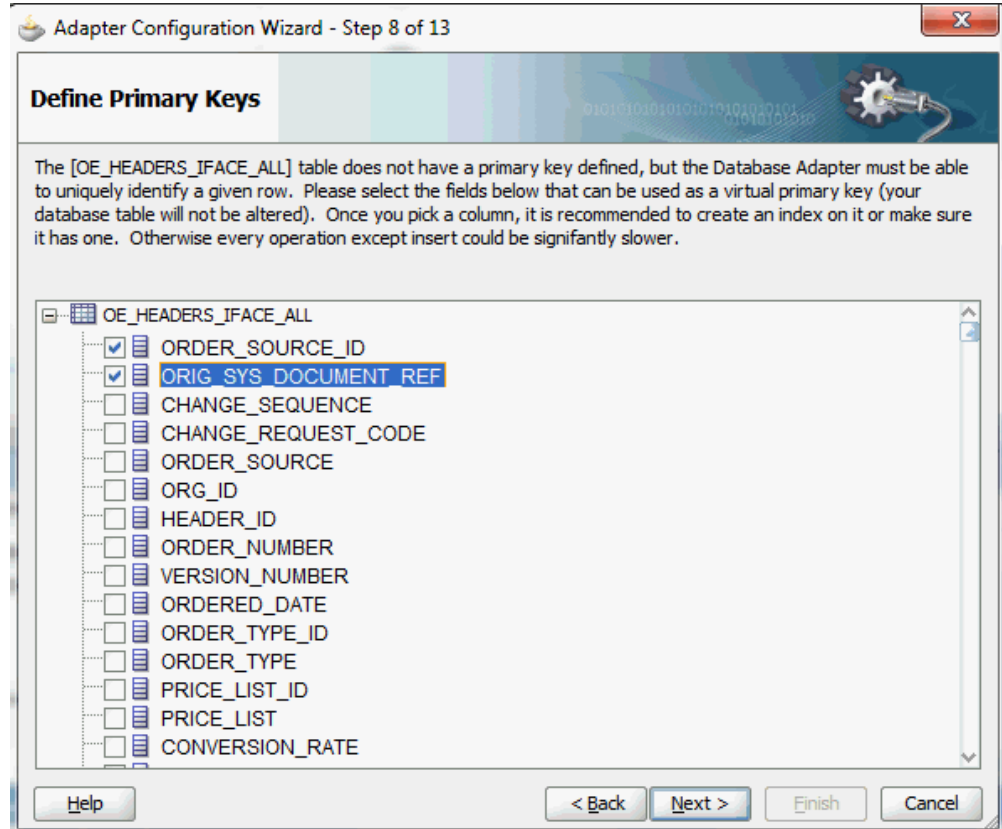

Select the following primary keys for the OE\_HEADERS\_IFACE\_ALL table:

- ORDER\_SOURCE\_ID
- ORIG\_SYS\_DOCUMENT\_REF

Click **Next**.

Select the same primary keys for the OE\_LINES\_IFACE\_ALL table.

## Adapter Configuration Wizard - Define Primary Keys Page for OE\_LINES\_IFACE\_ALL

Adapter Configuration Wizard - Step 9 of 13

### Define Primary Keys

The [OE\_LINES\_IFACE\_ALL] table does not have a primary key defined, but the Database Adapter must be able to uniquely identify a given row. Please select the fields below that can be used as a virtual primary key (your database table will not be altered). Once you pick a column, it is recommended to create an index on it or make sure it has one. Otherwise every operation except insert could be significantly slower.

OE\_LINES\_IFACE\_ALL

- ORDER\_SOURCE\_ID
- ORIG\_SYS\_DOCUMENT\_REF
- ORIG\_SYS\_LINE\_REF
- ORIG\_SYS\_SHIPMENT\_REF
- CHANGE\_SEQUENCE
- CHANGE\_REQUEST\_CODE
- ORG\_ID
- LINE\_NUMBER
- SHIPMENT\_NUMBER
- LINE\_ID
- SPLIT\_FROM\_LINE\_ID
- LINE\_TYPE\_ID
- LINE\_TYPE
- ITEM\_TYPE\_CODE
- INVENTORY\_ITEM\_ID

Help < Back Next > Finish Cancel

11. Click **Next**. The Relationships page appears. Click **Create** to open the Create Relationship dialog.

## Defining Relationships

Create Relationship

Please specify the parent and child tables, relation type and relation name. You also must specify the foreign key / primary key associations in the table below.

Parent Table: OE\_HEADERS\_IFACE\_ALL

Child Table: OE\_LINES\_IFACE\_ALL

OE\_HEADERS\_IFACE\_ALL has a 1:1 Relationship with OE\_LINES\_IFACE\_ALL

OE\_HEADERS\_IFACE\_ALL has a 1:1 Relationship with OE\_LINES\_IFACE\_ALL (Foreign Key on Child...

OE\_HEADERS\_IFACE\_ALL has a 1:M Relationship with OE\_LINES\_IFACE\_ALL

Private Owned

OE_HEADERS_IFACE_ALL	OE_LINES_IFACE_ALL
OE_HEADERS_IFACE_ALL.ORDER_SOURCE_ID	ORDER SOURCE ID
OE_HEADERS_IFACE_ALL.ORIG_SYS_DOCUMENT...	ORIG SYS DOCUMENT REF

Relationship Name: oeLinesIfaceAllCollection

Help OK Cancel

Enter the following information to define the relationship between the header and the detail table:

- Select the OE\_HEADERS\_IFACE\_ALL as the parent table and OE\_LINES\_IFACE\_ALL as the child table.
- Select the mapping type: OE\_HEADERS\_IFACE\_ALL has a 1:M Relationship with OE\_LINES\_IFACE\_ALL

**Note:** If foreign key constraints between tables already exist in the database, then two relationships are created automatically while importing tables. One of the relationships is 1:M relationship from the source table, which is the table containing the foreign key constraints, to the target table. The other relationship is a 1:1 back pointer from the target table to the source table.

- Select the **Private Owned** check box.
- Associate the foreign key fields with the primary key fields:
  - OE\_HEADERS\_IFACE\_ALL.ORDER\_SOURCE\_ID: ORDER\_SOURCE\_ID
  - OE\_HEADERS\_IFACE\_ALL.ORIG\_SYS\_DOCUMENT\_REF:  
ORIG\_SYS\_DOCUMENT\_REF
- The Relationship Name field is populated automatically by default. You can optionally specify a new name for the relationship you are creating.

Click **OK**. The newly created relationship information appears in the Relationships page.



## Adapter Configuration Wizard - Relationships Page

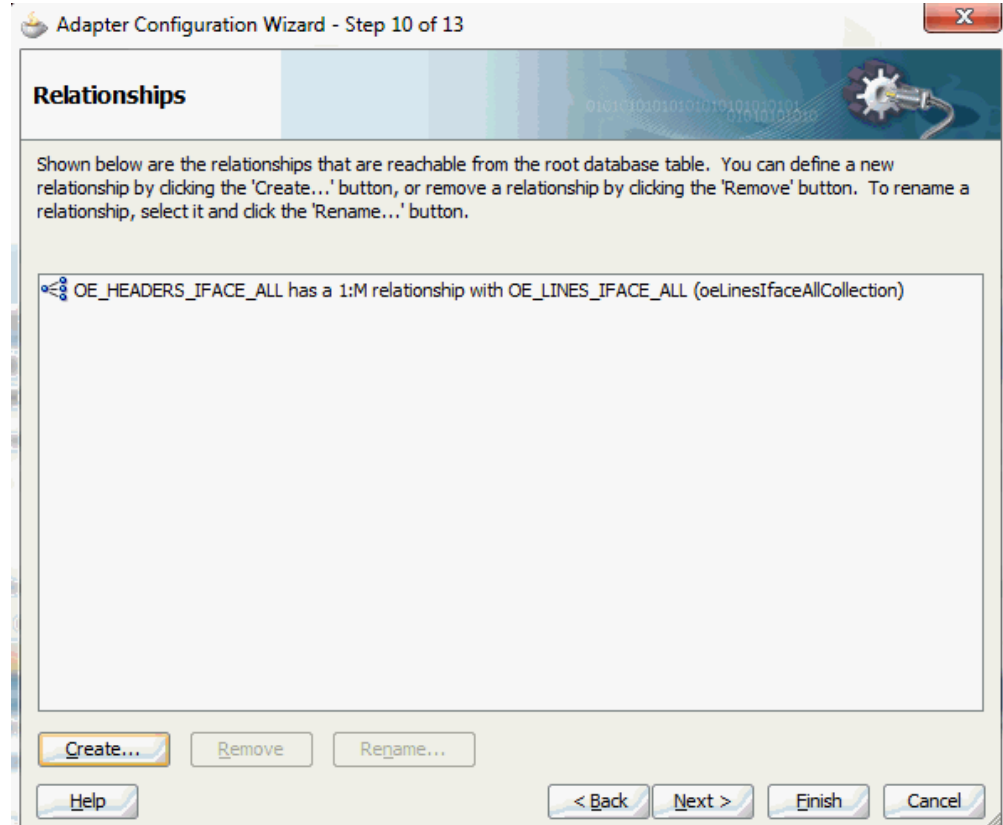

12. Click **Next**. The Attribute Filtering page appears. Leave default selections unchanged.

## Adapter Configuration Wizard - Attribute Filtering Page

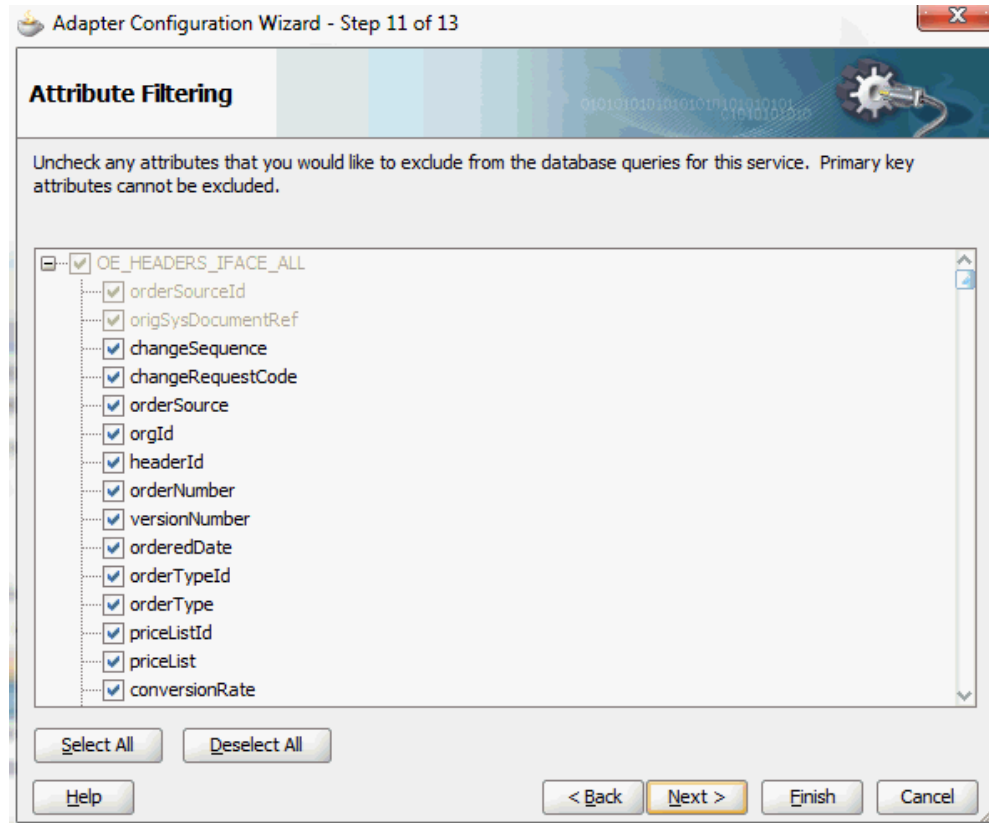

Click **Next**. The Advanced Options page appears.

Click **Next**.

13. Click **Finish**. The wizard generates the WSDL file corresponding to the selected interface. This WSDL file is now available for the partner link.

### Completing the Partner Link Configuration

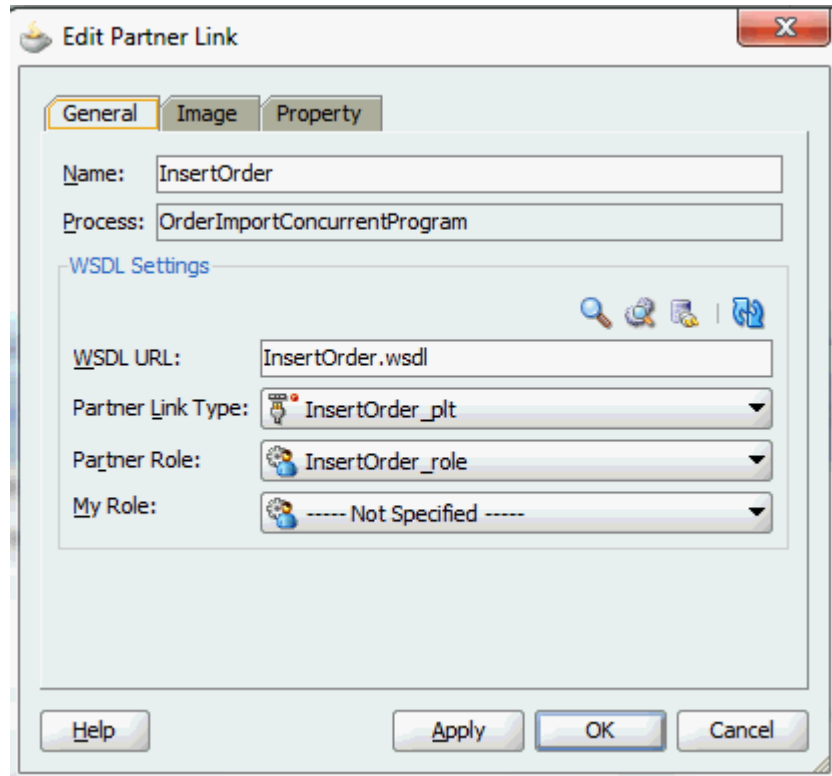

14. Click **Apply** and then **OK**. The partner link is created with the required WSDL settings.

### To add the second partner link:

1. Click **BPEL Services** in the Component palette.

Drag and drop **Oracle Applications** from the **BPEL Services** list into the right Partner Link swim lane of the process diagram after the first partner link. The Adapter Configuration Wizard Welcome page appears. Click **Next**.

2. Enter a service name in the **Service Name** field. For example, `ImportOrderCP`. Click **Next**. The Service Connection dialog appears.

### Specifying a Database Service Connection

The screenshot shows a window titled "Adapter Configuration Wizard - Step 3 of 4" with a close button in the top right corner. The main heading is "Service Connection". Below the heading, there is a blue banner with a gear icon and binary code. The text reads: "A Database Connection is required to configure this adapter. Select a database connection already defined in your project or create a New Connection." Below this, there is a "Connection:" dropdown menu with "OracleAppsConnection" selected. To the right of the dropdown are three icons: a green plus sign, a pencil, and a key. Below the dropdown, the following fields are displayed: "User Name: apps", "Driver: oracle.jdbc.OracleDriver", and "Connect String: jdbc:oracle:thin:@localhost:1521:sid01". Below these fields, there is a note: "Specify the JNDI name for the database. Note: The deployment descriptor of the Oracle Applications adapter must associate this JNDI name with configuration properties required by the adapter to access the database." Below the note is a "JNDI Name:" field with the text "eis/Apps/OracleAppsConnection" entered. At the bottom of the window, there are four buttons: "Help", "< Back", "Next >", "Finish", and "Cancel".

3. You can perform either one of the following options for your database connection:

**Note:** You need to connect to the database where Oracle Applications is running.

- You can create a new database connection by clicking the **Create a New Database Connection** icon.

How to define a new database connection, see *Create a New Database Connection*, page 5-13.

- You can select an existing database connection that you have configured earlier from the **Connection** drop-down list.

The Service Connection page will be displayed with the selected connection information. The JNDI (Java Naming and Directory Interface) name corresponding to the database connection appears automatically in the **Database Server JNDI Name** field. Alternatively, you can specify a JNDI name.

**Note:** When you specify a JNDI name, the deployment descriptor of the Oracle Applications adapter must associate this JNDI name with configuration properties required by the adapter to access the database.

The JNDI name acts as a placeholder for the connection used when your service is deployed to the BPEL server. This enables you to use different databases for development and later for production.

**Note:** For more information about JNDI concepts, refer to *Oracle Fusion Middleware User's Guide for Technology Adapters*.

4. Once you have completed creating a new connection for the service, you can add a concurrent program by browsing through the list available in Oracle Applications.

Click **Next**.

**For Oracle E-Business Suite Release 12:**

If you are connecting to Oracle E-Business Suite Release 12, then the **IREP File not present** dialog appears indicating that Adapter could not find the Oracle Integration Repository data file corresponding to the database you are connecting to Oracle Applications in your workspace. Absence of the data file would make browsing or searching of Integration Repository tree considerably slow. You can choose to extract the data file and create a local copy of the Integration Repository data file. Once it is created successfully, Adapter will pick it up automatically next time and retrieve data from your local Integration Repository.

You can select one of the following options:

- Click **Yes** to extract the Integration Repository data file.

### Extracting Integration Repository Data File

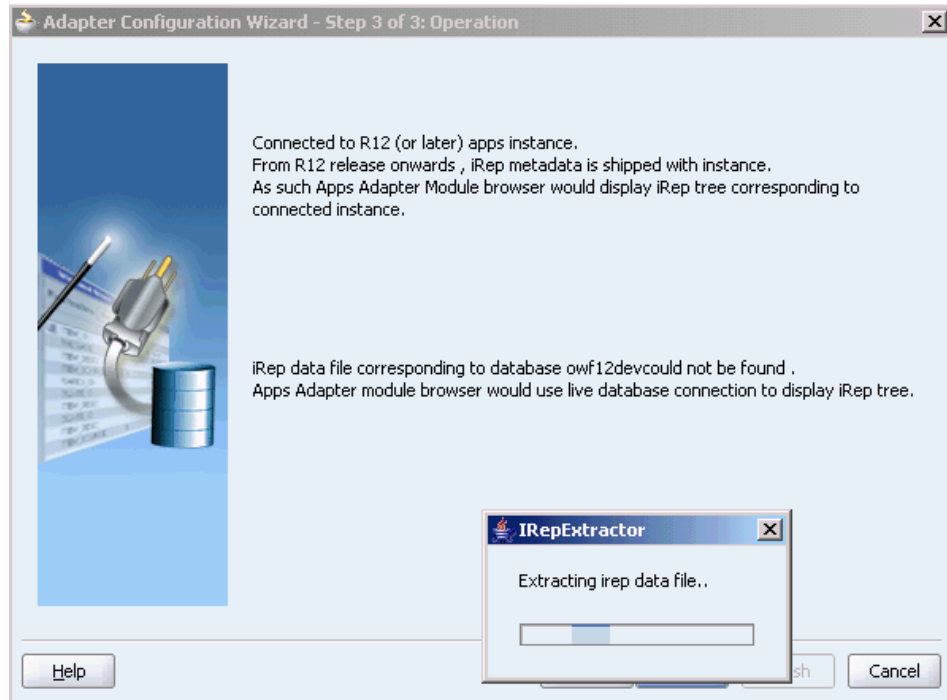

After the system successfully creates a local copy of the Integration Repository data file, next time when you connect to the database, you will find the **IRep Data File** field appears in the Operation dialog indicating where your local copy exists with the creation date and time as part of the file name.

### Using the Local Integration Repository Data File

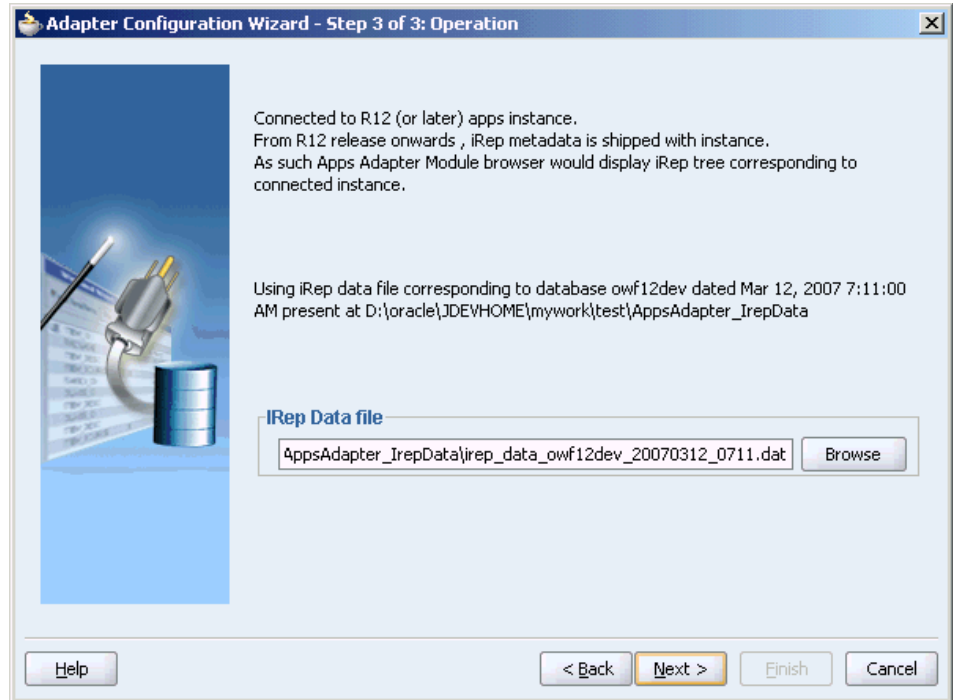

- Click **No** to query the Integration Repository data file from the live database you are connecting to display the Integration Repository tree.

Click **Next** in the Operation page to open the Oracle Applications Module Browser.

#### For Oracle E-Business Suite Release 11.5.9:

If you are connecting to an Oracle E-Business Suite Release 11.5.9 instance, you must select the interface type in the Adapter Configuration Wizard. Select **Tables/Views/APIs/Concurrent Programs** to proceed.

Click **Get Object** in the Application Interface dialog to open the Oracle Applications Module Browser.

5. The Oracle Applications Module Browser combines interface data from Oracle Integration Repository with information about the additional interfaces supported by Oracle Application Adapter, organized in a tree hierarchy.

**Specify a concurrent program from The Oracle Applications Module Browser**

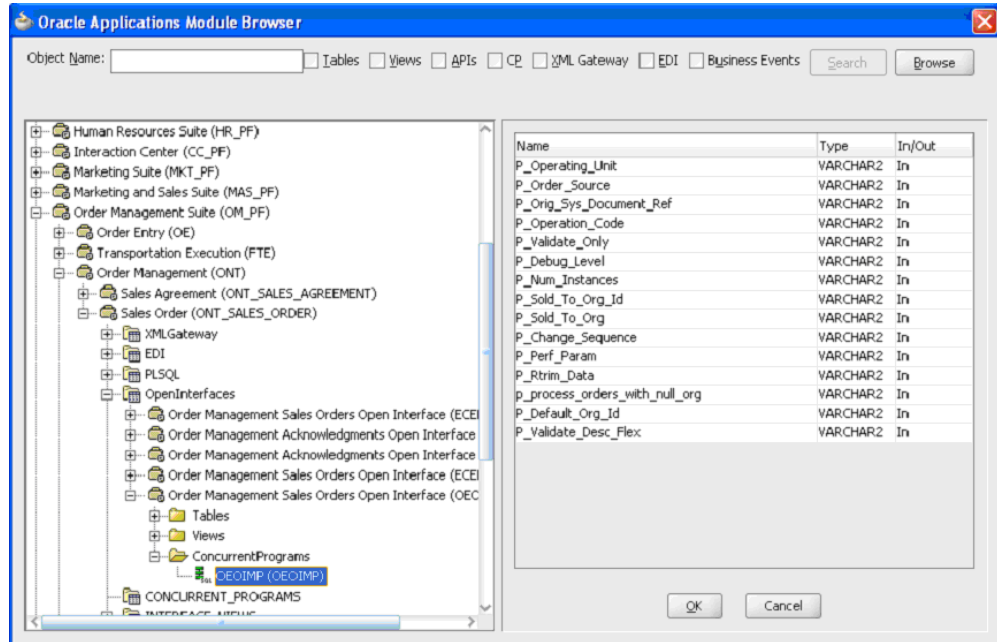

Navigate to *Order Management Suite (OM\_PF) > Order Management (ONT) > Sales Order (ONT\_SALES\_ORDER) > OpenInterfaces > Order Management Sales Orders Open Interface > ConcurrentPrograms* to select a concurrent program *OEOIMP (OEOIMP)*.

6. Click **OK**. The Application Interface page appears.



## Adapter Configuration Wizard - Application Interface Page

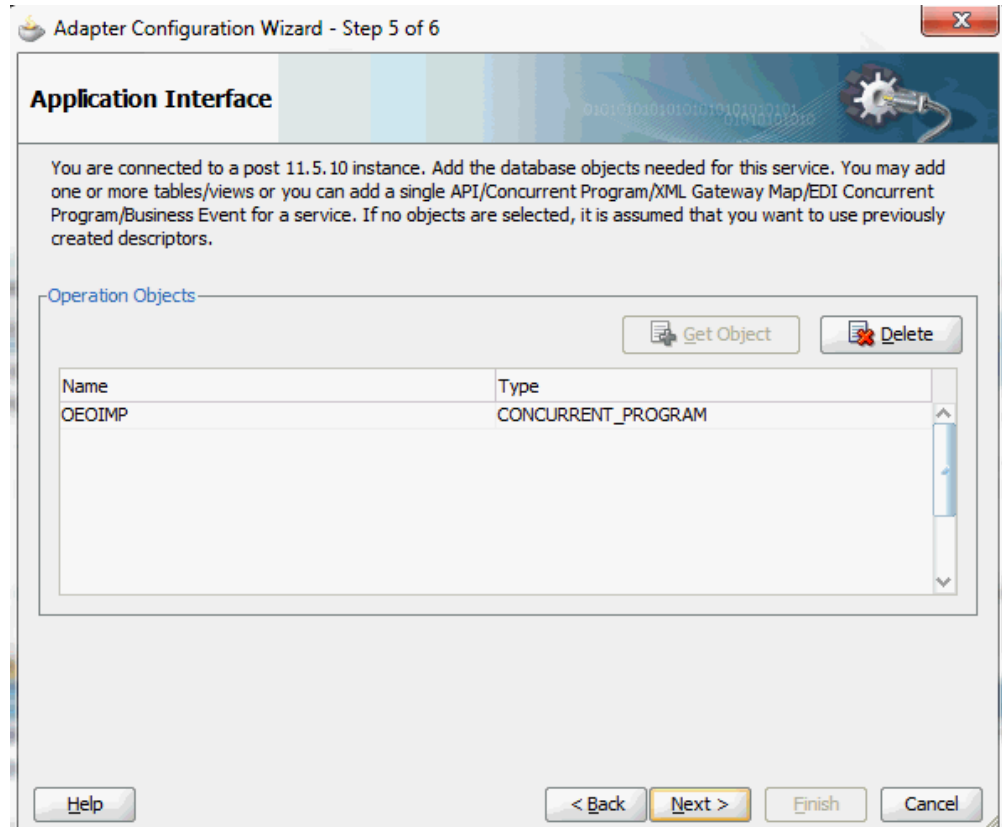

7. Click **Next**, then click **Finish** to complete the process of configuring Adapter for Oracle Applications.

The wizard generates the WSDL file corresponding to the XML schema. This WSDL file is now available for the partner link.

8. Click **Apply** and then **OK**. The partner link is created with the required WSDL settings.

## Adding Partner Links for File Adapter

Use this step to configure a BPEL process by synchronously reading payload from an input file to obtain the order details and concurrent program details.

Configure the following two partner links:

1. To obtain order details from an input file through Synchronous Read operation.
2. To obtain concurrent program details from an input file through Synchronous Read operation.

**To add the first Partner Link for File Adapter to read order details:**

1. In Oracle JDeveloper BPEL Designer, click **BPEL Services** in the Component palette.

Drag and drop **File Adapter** from the BPEL Services list into the right Partner Link swim lane before the first partner link `InsertOrder`. The Adapter Configuration Wizard Welcome page appears.

Click **Next**.

2. In the Service Name dialog, enter a name for the File Adapter service, for example, `getOrderDetails`.
3. Click **Next**. The Adapter Interface page appears.

### Specifying the Adapter Interface

Adapter Configuration Wizard - Step 3 of 4

#### Adapter Interface

The adapter interface is defined by a wsdl that is generated using the operation name and schema(s) specified later in this wizard. Optionally, the adapter interface may be defined by importing an existing WSDL.

Interface:  Define from operation and schema (specified later)

Import an existing WSDL

WSDL URL:

Port Type:

Operation:

Help < Back Next > Finish Cancel

Select the **Define from operation and schema (specified later)** radio button and click **Next**.

4. In the Operation page, specify the operation type. For example, select the **Synchronous Read File** radio button. This automatically populates the **Operation Name** field.

### Specifying the Operation

The screenshot shows a window titled "Adapter Configuration Wizard - Step 4 of 8". The main heading is "Operation". Below the heading, there is a paragraph of text: "The File Adapter supports four operations. There is a Read File operation that polls for incoming files in your local file system, a Write File operation that creates outgoing files, a Synchronous Read File operation that reads the current contents of a file, and a List Files operation that lists file names in specified locations. Specify the Operation type and Operation Name. Only one operation per Adapter Service may be defined using this wizard." Below this text, there are four radio button options under the label "Operation Type": "Read File", "Write File", "Synchronous Read File" (which is selected), and "List Files". Below the radio buttons, there is a text input field labeled "Operation Name:" containing the text "SynchRead". At the bottom of the window, there are four buttons: "Help", "< Back", "Next >" (which is highlighted), "Finish", and "Cancel".

Click **Next** to access the File Directories page.

5. Select the **Logical Name** radio button and specify directory for incoming files, such as `inputDir`.

Ensure the **Delete files after successful retrieval** check box is not selected.

### Configuring the Input File

The screenshot shows a window titled "Adapter Configuration Wizard - Step 5 of 8". The main heading is "File Directories". Below the heading, there is a text box with the instruction: "Enter directory information for the incoming file of the Synchronous Read File operation." Below this, there are two radio buttons: "Physical Path" (unselected) and "Logical Name" (selected). There are three input fields, each with a "Browse" button to its right. The first input field is labeled "Directory for Incoming Files (physical path):" and contains the text "inputDir". The second input field is labeled "Archive Directory for Processed Files (physical path):" and is empty. The third input field is labeled "Delete files after successful retrieval" and is empty. At the bottom of the window, there are four buttons: "Help", "< Back", "Next >", and "Cancel".

Click **Next** to open the File Name page.

6. Enter the name of the file for the synchronous read file operation. For example, enter `order_data.xml`. Click **Next**. The Messages page appears.
7. Select the 'browse for schema file' icon next to the URL field to open the Type Chooser.

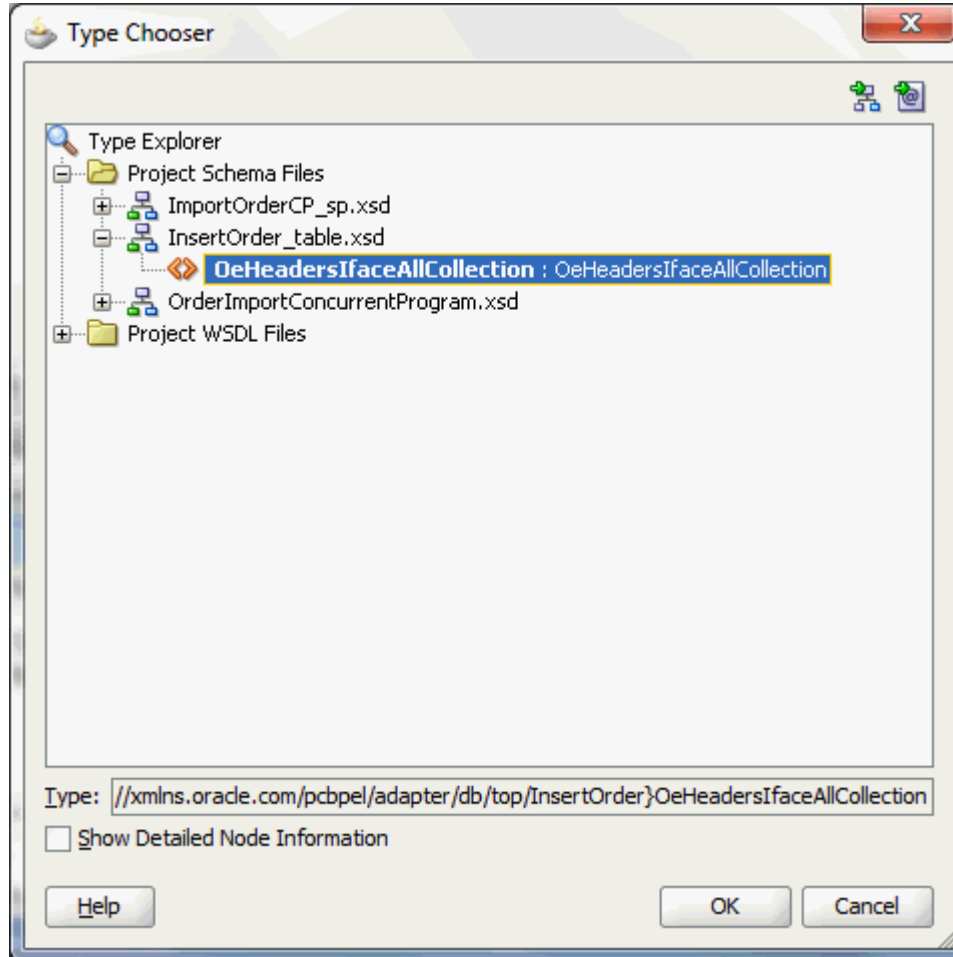

Click Type Explorer and select *Project Schema Files* > *InsertOrder\_table.xsd* > *OeHeadersIfaceAllCollection*. Click **OK**.

The selected schema information will be automatically populated in the URL and Schema Element fields.

## Specifying Message Schema

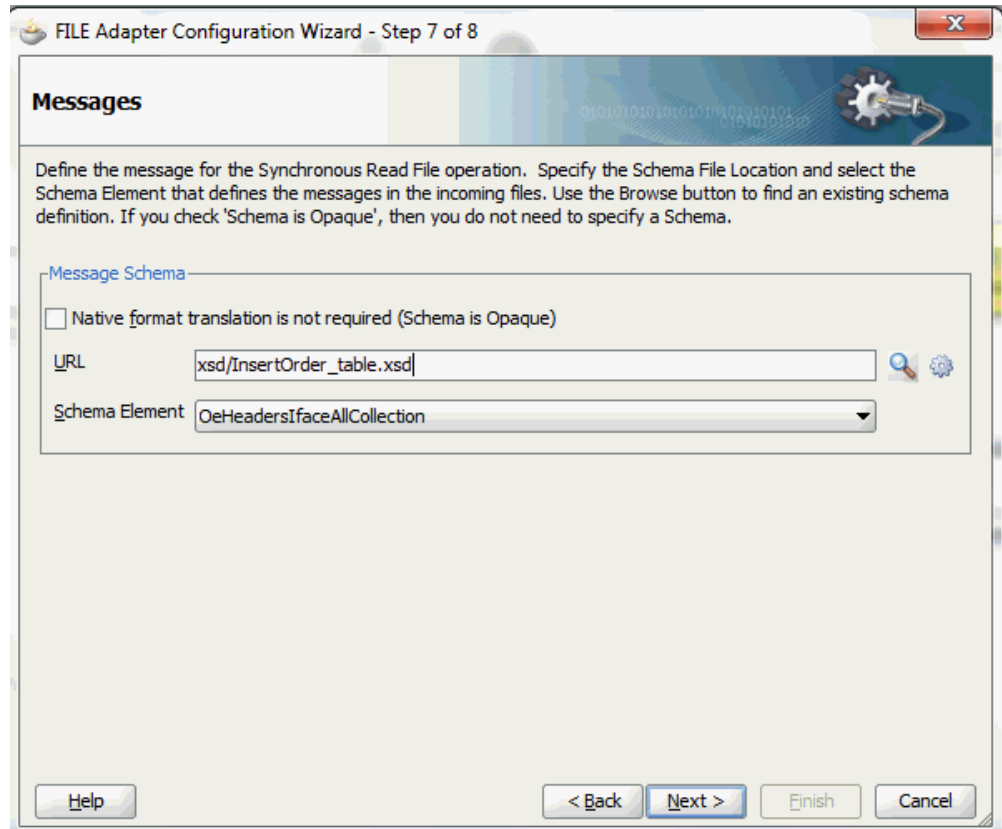

8. Click **Next** and then **Finish**. The wizard generates the WSDL file corresponding to the partner link. The main Create Partner Link dialog box appears, specifying the new WSDL file `getOrderDetails.wsdl`.

Click **Apply** and **OK** to complete the configuration and create the partner link with the required WSDL settings for the File Adapter service.

The `getOrderDetails` Partner Link appears in the BPEL process diagram.

### To add the second Partner Link for File Adapter to read concurrent program details:

1. In Oracle JDeveloper BPEL Designer, click **BPEL Services** in the Component palette.

Drag and drop **File Adapter** from the **BPEL Services** list into the right Partner Link swim lane after the first File Adapter partner link `getOrderDetails`. The Adapter Configuration Wizard Welcome page appears.

Click **Next**.

2. In the Service Name page, enter a name for the File Adapter service, such as `getCPDetails`.

3. Click **Next**. The Adapter Interface page appears.

### Specifying the Adapter Interface

The screenshot shows a window titled "Adapter Configuration Wizard - Step 3 of 4" with a close button in the top right corner. The main heading is "Adapter Interface". Below the heading, there is a descriptive paragraph: "The adapter interface is defined by a wsdl that is generated using the operation name and schema(s) specified later in this wizard. Optionally, the adapter interface may be defined by importing an existing WSDL." Under the heading "Interface:", there are two radio buttons. The first, "Define from operation and schema (specified later)", is selected and highlighted with a yellow box. The second is "Import an existing WSDL". Below these are three input fields: "WSDL URL:" with a text box and a file icon; "Port Type:" with a dropdown menu; and "Operation:" with a dropdown menu. At the bottom of the window, there are four buttons: "Help", "< Back", "Next >" (which is highlighted in blue), and "Finish". A "Cancel" button is also present to the right of the "Finish" button.

Select the **Define from operation and schema (specified later)** radio button and click **Next**.

4. In the Operation page, specify the operation type. For example, select the **Synchronous Read File** radio button. This automatically populates the **Operation Name** field.



### Specifying the Operation

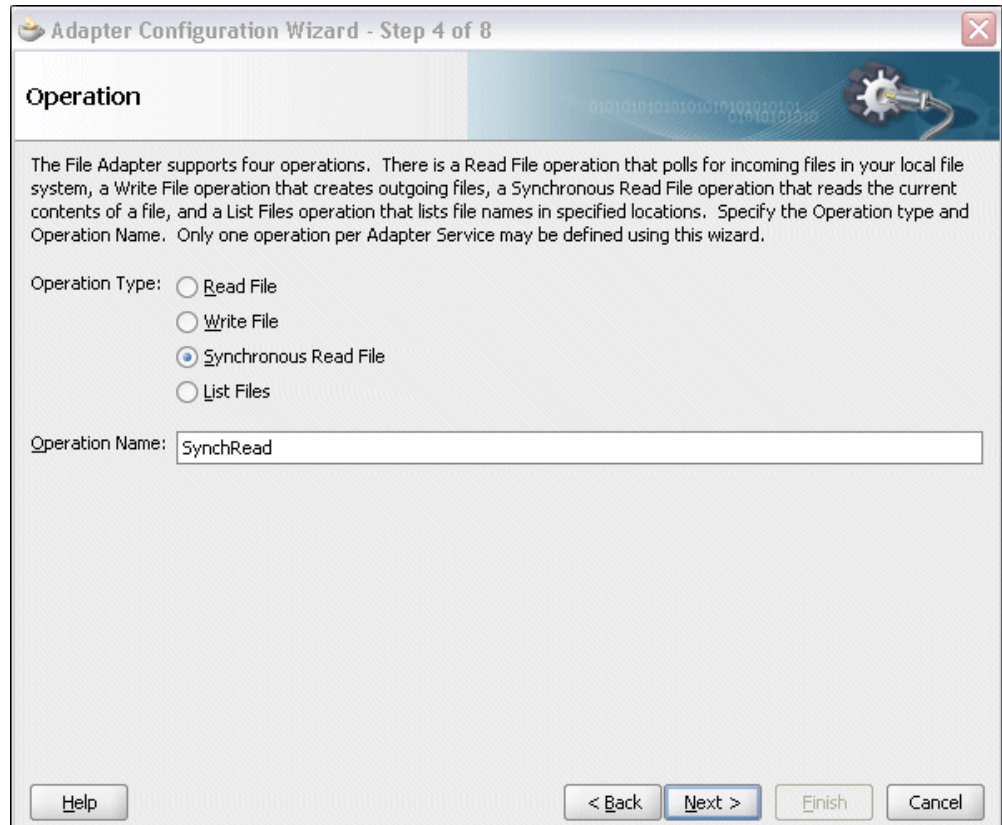

Click **Next** to access the File Directories page.

5. Select the **Logical Name** radio button and specify directory for incoming files, such as `inputDir`.

Ensure the **Delete files after successful retrieval** check box is not selected.

### Configuring the Input File

The screenshot shows a window titled "Adapter Configuration Wizard - Step 5 of 8" with a close button in the top right corner. The main heading is "File Directories". Below the heading, there is a text box with the instruction: "Enter directory information for the incoming file of the Synchronous Read File operation." Below this, there are two radio buttons: "Physical Path" (unselected) and "Logical Name" (selected). There are three input fields, each with a "Browse" button to its right. The first input field is labeled "Directory for Incoming Files (physical path):" and contains the text "inputDir". The second input field is labeled "Archive Directory for Processed Files (physical path):" and is currently empty. The third input field is labeled "Delete files after successful retrieval" and is also empty. At the bottom of the window, there are four buttons: "Help", "< Back", "Next >", "Finish", and "Cancel".

Click **Next** to open the File Name page.

6. Enter the name of the file for the synchronous read file operation. For example, enter `cp_data.xml`. Click **Next** to open the Messages page.
7. Select the 'browse for schema file' icon next to the URL field to open the Type Chooser.

Click Type Explorer and select *Project Schema Files > ImportOrderCP\_sp.xsd > InputParameters*. Click **OK**.

The selected schema information will be automatically populated in the URL and Schema Element fields.

## Specifying Message Schema

The screenshot shows a dialog box titled "FILE Adapter Configuration Wizard - Step 7 of 8". The main heading is "Messages". Below the heading, there is a descriptive text: "Define the message for the Synchronous Read File operation. Specify the Schema File Location and select the Schema Element that defines the messages in the incoming files. Use the Browse button to find an existing schema definition. If you check 'Schema is Opaque', then you do not need to specify a Schema." Below this text is a section titled "Message Schema" containing a checkbox labeled "Native format translation is not required (Schema is Opaque)", which is currently unchecked. Below the checkbox is a text input field for "URL" containing the text "xsd/ImportOrderCP\_sp.xsd". To the right of the URL field are two small icons: a magnifying glass and a gear. Below the URL field is a dropdown menu for "Schema Element" with "InputParameters" selected. At the bottom of the dialog box, there are four buttons: "Help", "< Back", "Next >", and "Finish". The "Next >" button is highlighted with a blue border.

8. Click **Next** and then **Finish**. The wizard generates the WSDL file corresponding to the partner link. The main Create Partner Link dialog box appears, specifying the new WSDL file `getCPDetails.wsdl`.

### Completing the Partner Link Configuration

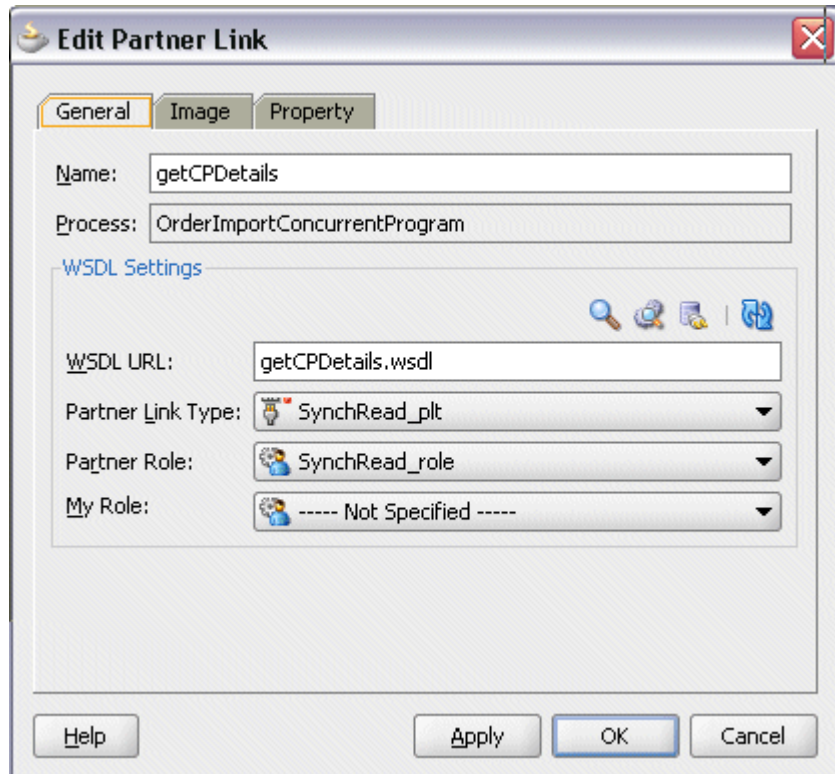

Click **Apply** and **OK** to complete the configuration and create the partner link with the required WSDL settings for the File Adapter service.

The `getCPDetails` Partner Link appears in the BPEL process diagram.

## Configuring Invoke Activities

After adding and configuring partner links, you need to configure the following four Invoke activities:

1. To get the order details by invoking the `getOrderDetails` partner link through Synchronous Read operation to read the order from an input file.
2. To get the concurrent program details by invoking the `getCPDetails` partner link through Synchronous Read operation to read the concurrent program information from an input file.
3. To insert order data into Open Interface tables by invoking `InsertOrder` partner link.
4. To import order data from Open Interface tables to Oracle Applications by invoking

ImportOrderCP concurrent program partner link.

**To add the first Invoke activity for a partner link to get order details:**

1. In Oracle JDeveloper BPEL Designer, expand the **BPEL Constructs** from the Component Palette. Drag and drop the first **Invoke** activity into the center swim lane of the process diagram, between the **receiveInput** and **callbackClient** activities.

**Adding an Invoke Activity**

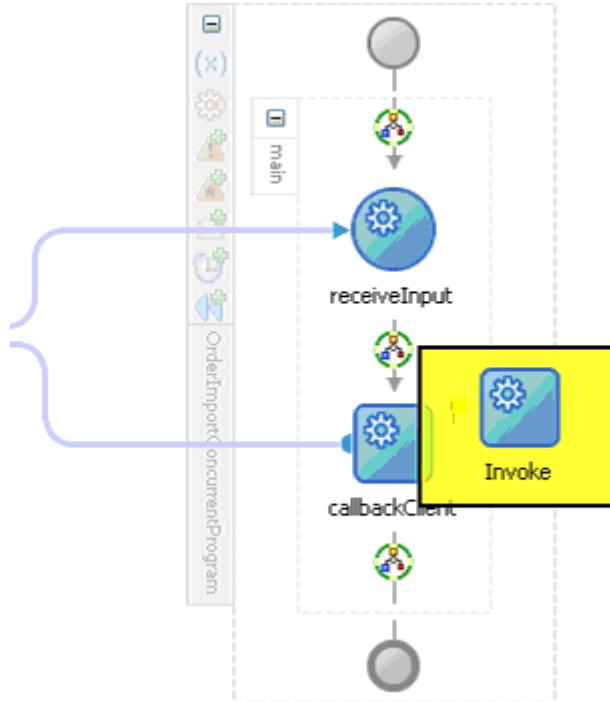

2. Link the Invoke activity to the `getOrderDetails` service. The Edit Invoke dialog appears.
3. Enter a name for the Invoke activity, then click the **Create** icon next to the **Input Variable** field to create a new variable. The Create Variable dialog box appears.
4. Select **Global Variable**, then enter a name for the variable. You can also accept the default name. Click **OK**.
5. Click the **Create** icon next to the **Output Variable** field to create a new variable. The Create Variable dialog box appears.
6. Select **Global Variable**, then enter a name for the variable. You can also accept the default name. Click **OK** to return to the Edit Invoke dialog box.

Click **Apply** and then **OK** to finish configuring the Invoke activity.

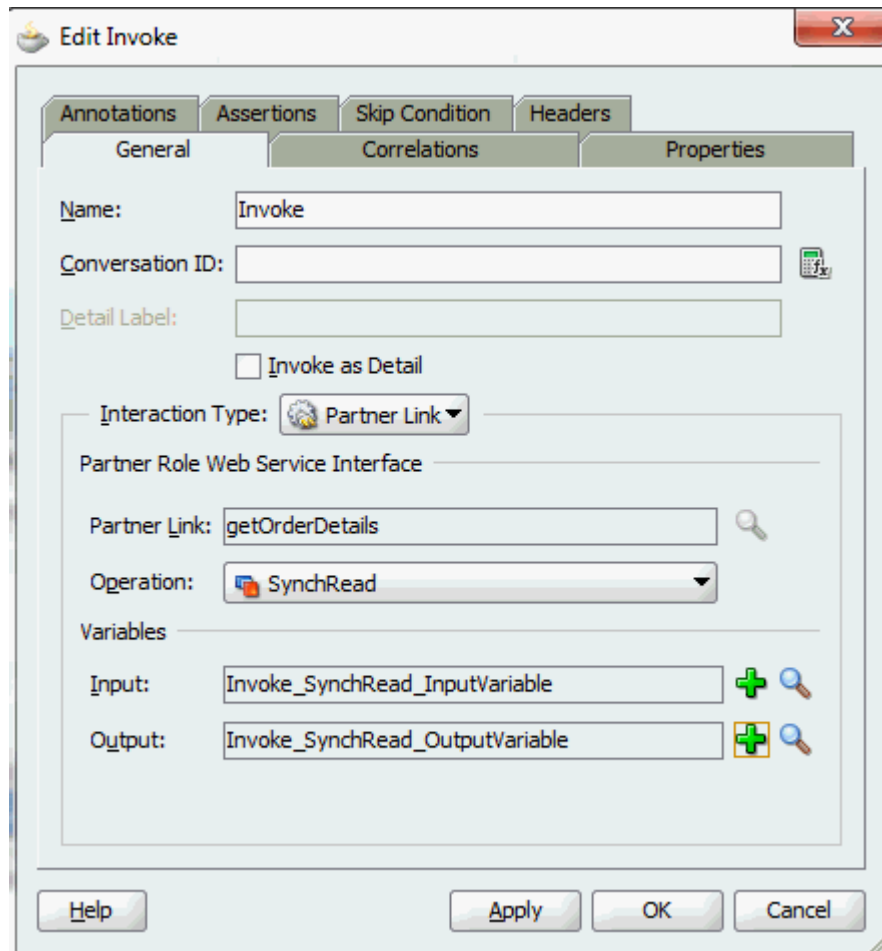

The Invoke activity appears in the process diagram.

**To add the second Invoke activity for a partner link to get concurrent program details:**

1. In JDeveloper BPEL Designer, expand the **BPEL Constructs** from the Component Palette. Drag and drop the second **Invoke** activity into the center swim lane of the process diagram right after the first **Invoke** activity.
2. Link the Invoke activity to the `getCPDetails` service. The Edit Invoke dialog appears.
3. Repeat Step 3 to Step 6 described in the first Invoke activity procedure.

The input and output variables should be populated in the Edit Invoke dialog box.

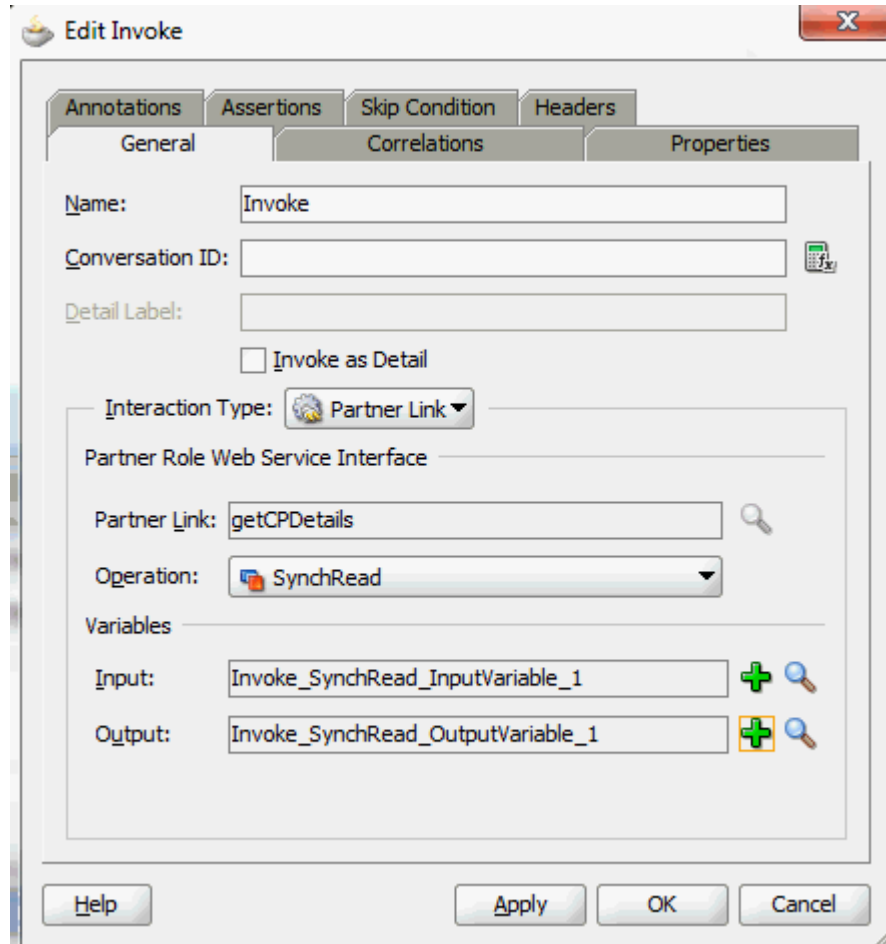

**To add the third Invoke activity for a partner link to insert order data into Open Interface tables:**

1. In JDeveloper BPEL Designer, expand the **BPEL Constructs** from the Component Palette. Drag and drop the third **Invoke** activity into the center swim lane of the process diagram, between the second **Invoke** and **callbackClient** activities.
2. Link the Invoke activity to the `InsertOrder` service. The Edit Invoke dialog box appears.
3. Repeat Step 3 to Step 4 described in the first Invoke activity procedure. Click **OK** in the Edit Invoke dialog box to finish configuring the second Invoke activity.

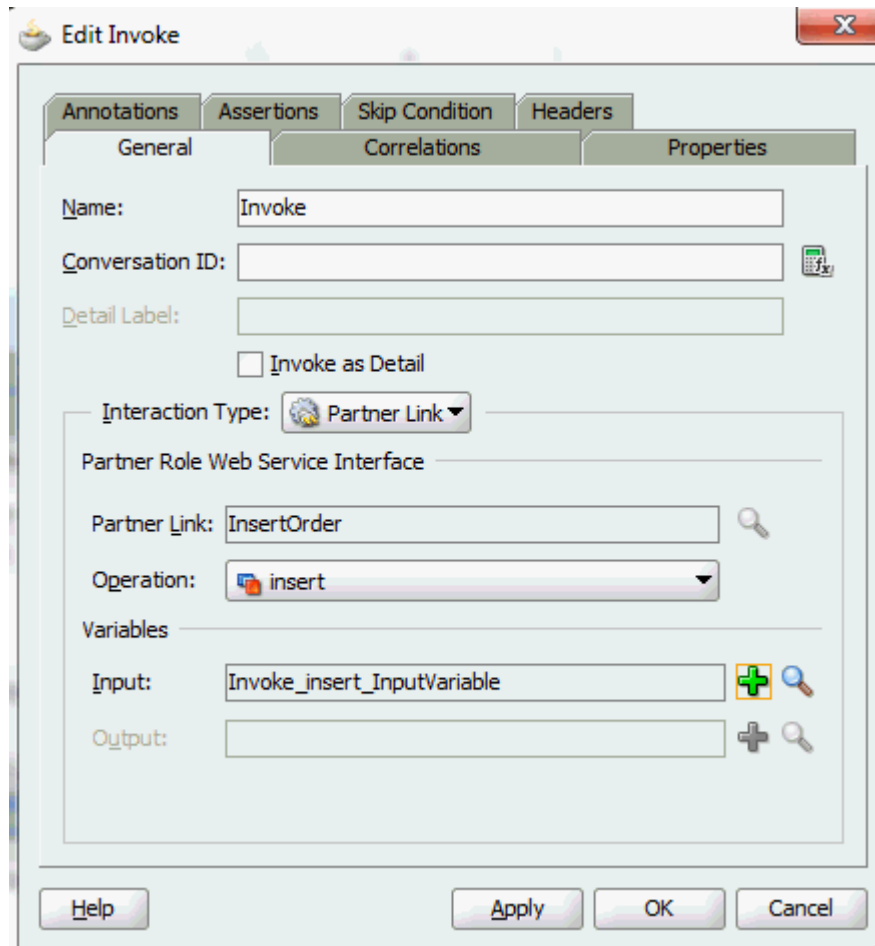

**To add the fourth Invoke activity for a partner link to import the order information to Oracle Applications:**

1. In JDeveloper BPEL Designer, expand the **BPEL Constructs** from the Component Palette. Drag and drop the fourth **Invoke** activity into the center swim lane of the process diagram, between the third **Invoke** and **callbackClient** activities.
2. Link the Invoke activity to the `ImportOrderCP` service. The Edit Invoke dialog box appears.
3. Repeat Step 3 to Step 6 described in the first Invoke activity procedure.  
The input and output variables should be populated in the Edit Invoke dialog box.



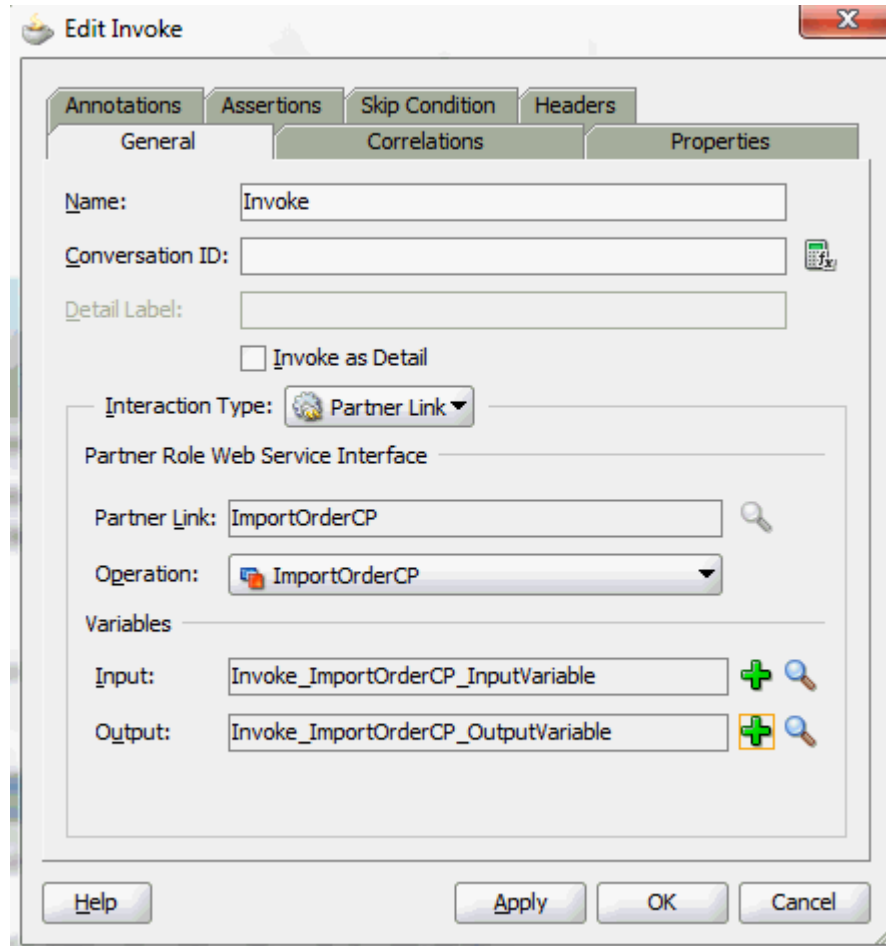

#### 4. Setting Header Properties for Applications Context

Use the following steps to set the header message properties required to pass applications context required to complete the BPEL process:

1. Select the Properties tab in the Edit Invoke dialog box.
2. Scroll down to locate the `jca.apps.Username` property from the list and double click the associated value field to enable the **Adapter Property Value** icon.
3. Click the icon to open the Adapter Property Value dialog for the selected `jca.apps.Username` property.

### Setting Header Message Properties

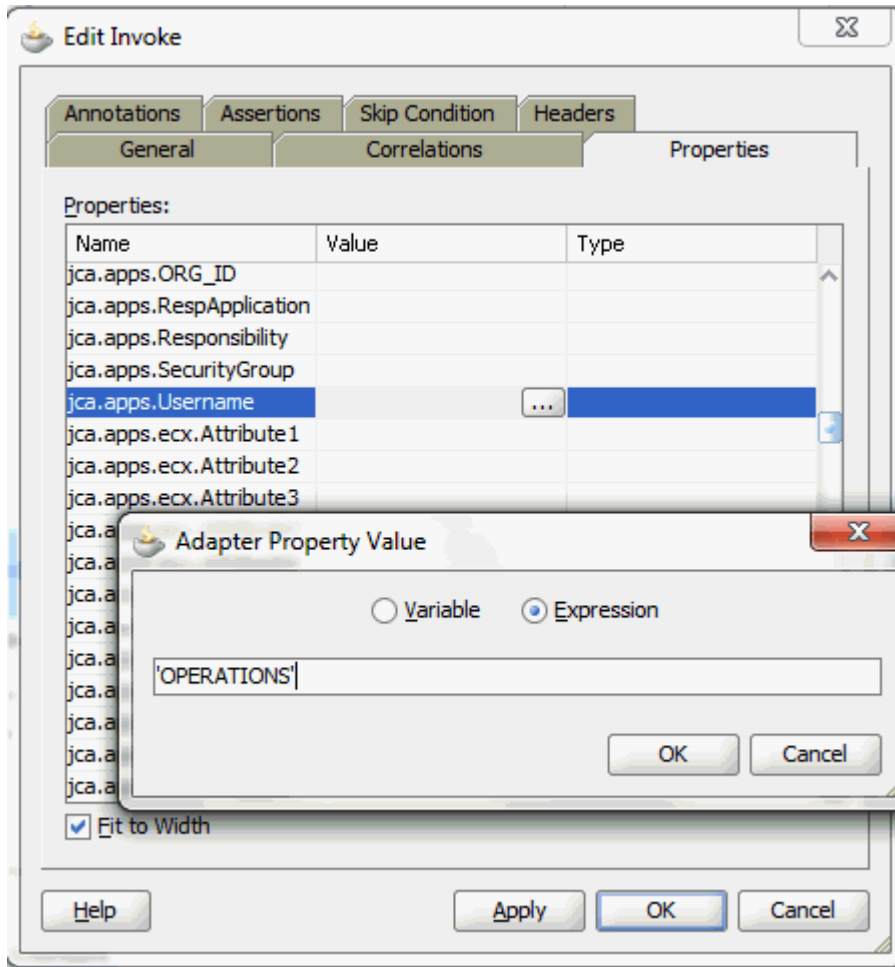

4. Select the **Expression** radio button and enter 'OPERATIONS' as the property value.  
Click **OK**.
5. Repeat Step 2 to Step 4 to assign the following properties:
  - 'Order Management Super User, Vision Operations (USA)' for jca.apps.Responsibility.
  - 204 for jca.apps.ORG\_ID
5. Click **Apply** and then **OK** to complete the Invoke activity.

## Configuring Assign Activities

Based on the BPEL process scenario, you need to configure the following two Assign activities:

1. To pass the output of File Adapter's Synchronous Read (`getOrderDetails`) service as an input to the Open Interface `InsertOrder` service.
2. To set the payload of the Concurrent Program (`ImportOrderCP`) service.

### To add the first Assign activity:

1. In JDeveloper BPEL Designer, expand the **BPEL Constructs** from the Component Palette.

Drag and drop the first **Assign** activity into the center swim lane of the process diagram, between the first and second **Invoke** activities that you just created earlier.

2. Double-click the **Assign** activity to access the Edit Assign dialog.

Click the General tab to enter a name for the Assign activity. For example, `SetOrderDetails`.

3. Select the Copy Rules tab and expand the target trees:

- In the From navigation tree, navigate to **Variable > Process > Variables > Invoke\_SynchRead\_OutputVariable** and select **body**.
- In the To navigation tree, navigate to **Variable > Process > Variables > Invoke\_insert\_InputVariable** and select **OeHeadersIfaceAllCollection**.

Drag the source node (body) to connect to the target node (`OeHeadersIfaceAllCollection`) that you just specified. This creates a line that connects the source and target nodes. The copy rule is displayed in the From and To sections at the bottom of the Edit Assign dialog box.

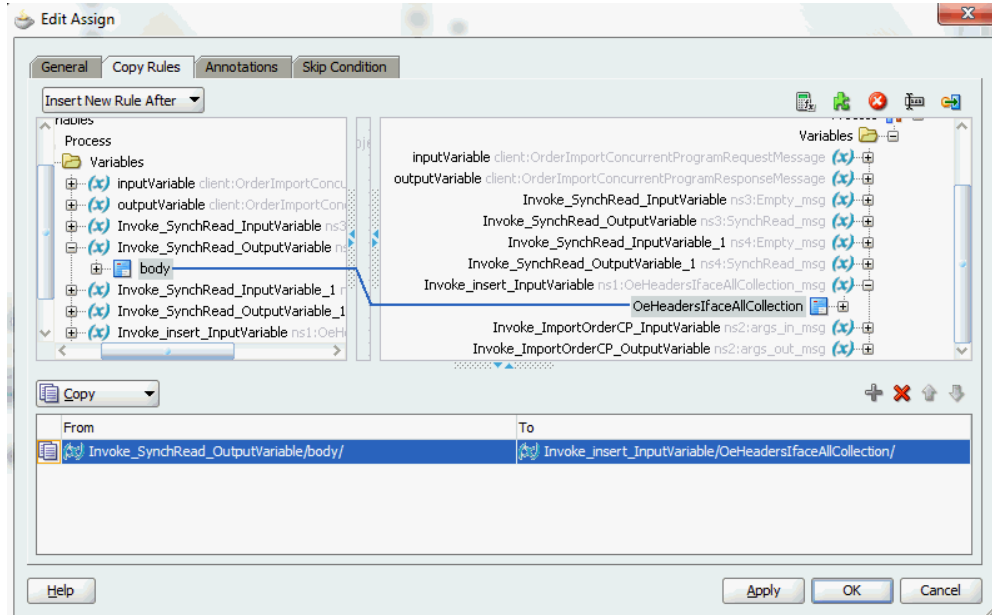

4. Click **Apply** and then **OK** to complete the configuration of the Assign activity.

#### To add the second Assign activity:

1. In JDeveloper BPEL Designer, expand the **BPEL Constructs** from the Component Palette.

Drag and drop the second **Assign** activity into the center swim lane of the process diagram, between the third and fourth **Invoke** activities that you just created earlier.

2. Double-click the **Assign** activity to access the Edit Assign dialog.

Click the **General** tab to enter a name for the Assign activity. For example, `SetCPDetails`.

3. Select the **Copy Rules** tab and expand the target trees:

- In the **From** navigation tree, navigate to **Variable > Process > Variables > Invoke\_SynchRead\_OutputVariable\_1** and select **body**.
- In the **To** navigation tree, navigate to **Variable > Process > Variables > Invoke\_ImportOrderCP\_InputVariable** and select **InputParameters**.

Drag the source node (**body**) to connect to the target node (**InputParameters**) that you just specified. This creates a line that connects the source and target nodes. The copy rule is displayed in the **From** and **To** sections at the bottom of the Edit Assign dialog box.

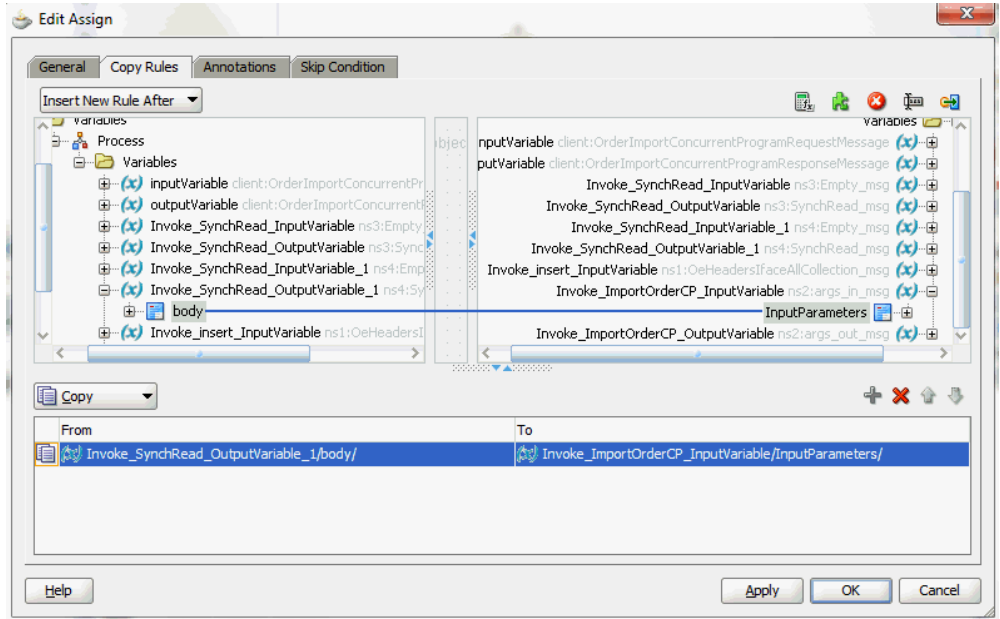

4. Click **Apply** and then **OK** to complete the configuration of the Assign activity.

### Completed Concurrent Program BPEL Process Project

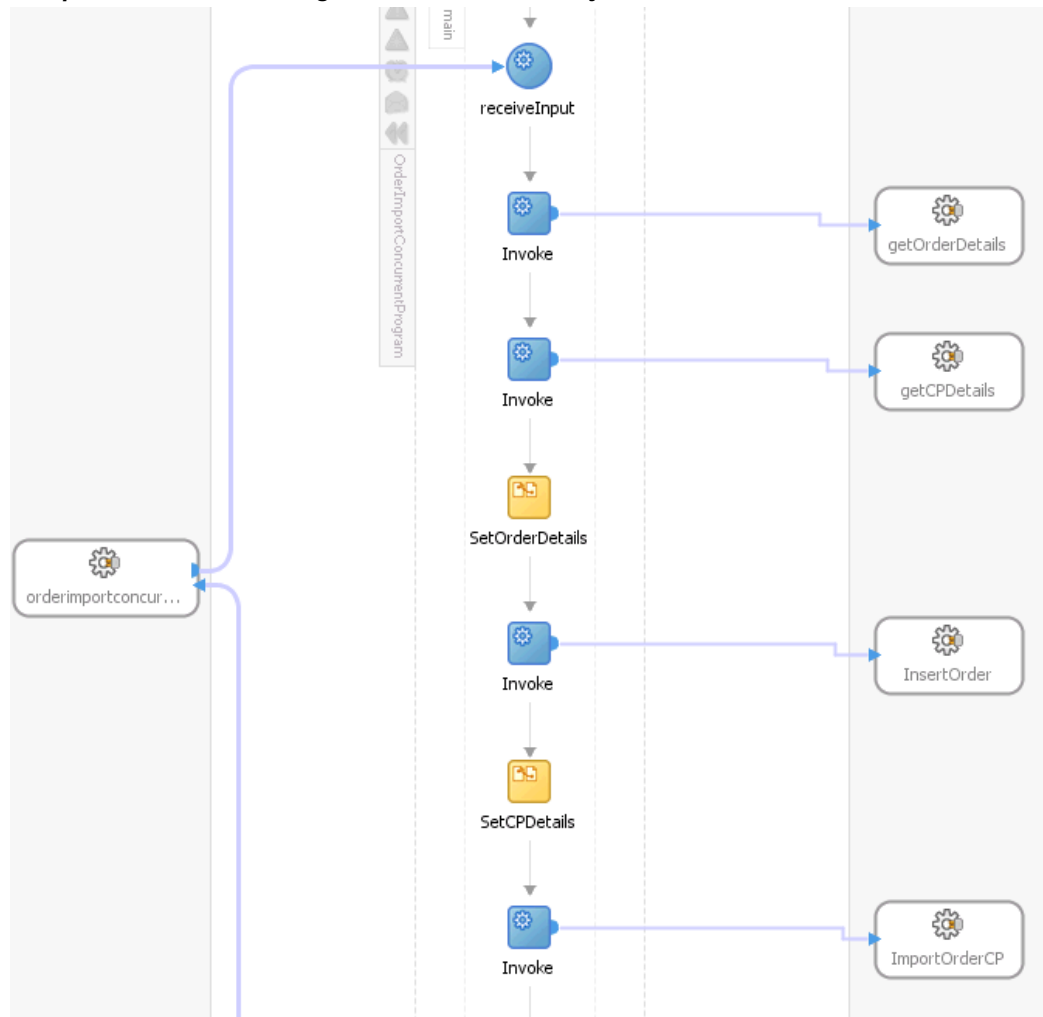

Click the `composite.xml` to display the Oracle JDeveloper composite diagram:

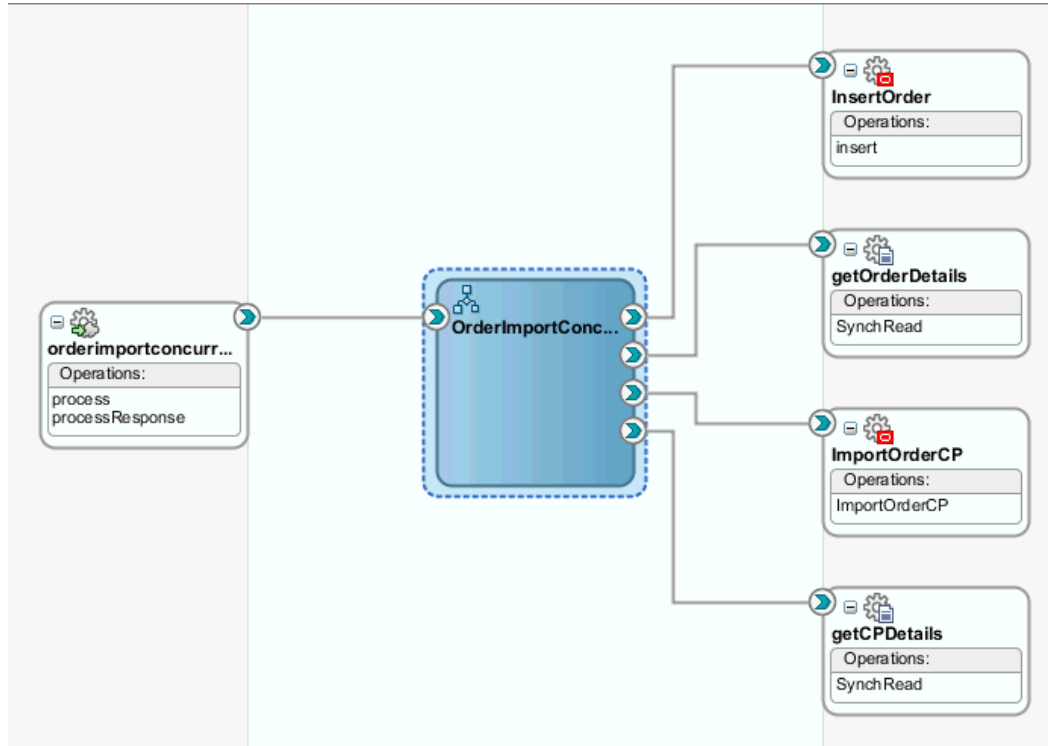

**Note:** Click the Source tab of `composite.xml` to enter a value for the physical directory `inputDir` for the reference `getOrderDetails` and `getCPDetails` (such as `/usr/tmp`).

```
<property name="inputDir" type="xs:string"
many="false" override="may">/usr/tmp</property>
```

## Specifying the Physical Directory for the Property

```
<Implementation.bpel src="OrderImportConcurrentProgram.bpel"/>
</component>
<reference name="InsertOrder" ui:wSDLLocation="InsertOrder.wsdl">
  <interface.wSDL interface="http://xmlns.oracle.com/pcbpel/adapter/apps/OrderImportConc
  <binding.jca config="InsertOrder_apps.jca"/>
  <property name="jca.retry.count" type="xs:int" many="false" override="may">9</property>
  <property name="jca.retry.interval" type="xs:int" many="false"
  override="may">1</property>
  <property name="jca.retry.backoff" type="xs:int" many="false"
  override="may">2</property>
</reference>
<reference name="getOrderDetails" ui:wSDLLocation="getOrderDetails.wsdl">
  <interface.wSDL interface="http://xmlns.oracle.com/pcbpel/adapter/file/OrderImportConc
  <binding.jca config="getOrderDetails_file.jca"/>
  <property name="inputDir" type="xs:string" many="false" override="may"/usr/tmp/</prope
</reference>
<reference name="ImportOrderCP" ui:wSDLLocation="ImportOrderCP.wsdl">
  <interface.wSDL interface="http://xmlns.oracle.com/pcbpel/adapter/apps/OrderImportConc
  <binding.jca config="ImportOrderCP_apps.jca"/>
</reference>
<reference name="getCPDetails" ui:wSDLLocation="getCPDetails.wsdl">
  <interface.wSDL interface="http://xmlns.oracle.com/pcbpel/adapter/file/OrderImportConc
  <binding.jca config="getCPDetails_file.jca"/>
  <property name="inputDir" type="xs:string" many="false" override="may"/usr/tmp/</prope
</reference>
<wire>
  <source.uri>orderimportconcurrentprogram_client_ep</source.uri>
  <target.uri>OrderImportConcurrentProgram/orderimportconcurrentprogram_client</target.u
</wire>
<wire>
  <source.uri>OrderImportConcurrentProgram/InsertOrder</source.uri>
  <target.uri>InsertOrder</target.uri>

```

## Run-Time Tasks for Concurrent Programs

After designing the SOA Composite application with BPEL process, the next step is to deploy, run and monitor it.

1. Deploy the SOA Composite application with BPEL process, page 7-54
2. Test the Deployed SOA Composite application with BPEL process, page 7-59
3. Verify records in Oracle E-Business Suite, page 7-62

## Deploying the SOA Composite Application with BPEL Process

To invoke the services from the BPEL client contained in the SOA composite, the SOA composite needs to be deployed to the Oracle WebLogic managed server. This can be achieved using Oracle JDeveloper. Once the composite is deployed, it can be tested from the Oracle Enterprise Manager Fusion Middleware Control Console.

### Prerequisites

Before deploying the SOA composite with BPEL process using Oracle JDeveloper, you must have established the connectivity between the design-time environment and the run-time server. For more information, see *Configuring the Data Source in Oracle*



WebLogic Server, page A-3 and Creating an Application Server Connection, page A-12.

**Note:** If a local instance of the WebLogic Server is used, start the WebLogic Server by selecting **Run > Start Server Instance** from Oracle JDeveloper. Once the WebLogic Admin Server "DefaultServer" instance is successfully started, the <Server started in Running mode> and DefaultServer started message in the Running:DefaultServer and Messages logs should appear.

### To deploy the SOA Composite application with BPEL process:

1. Select the SOA Composite project in the Applications Navigator.
2. Right-click the project name, then select **Deploy > [project name] > [serverConnection]** from the menu that appears.

For example, you can select **Deploy > OrderImportConcurrentProgram > soa-server1** to deploy the process if you have the connection set up appropriately.

#### Deploying the SOA Composite application

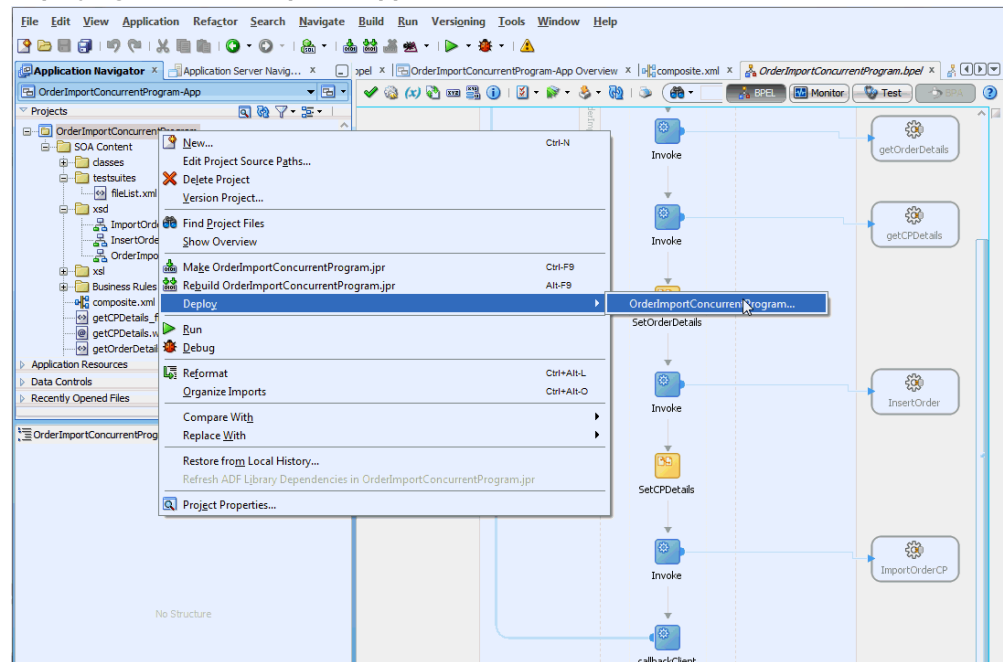

**Note:** If this is the first time to set up server connection, then the Deployment Action window appears. Select 'Deploy to Application Server' and click Next.

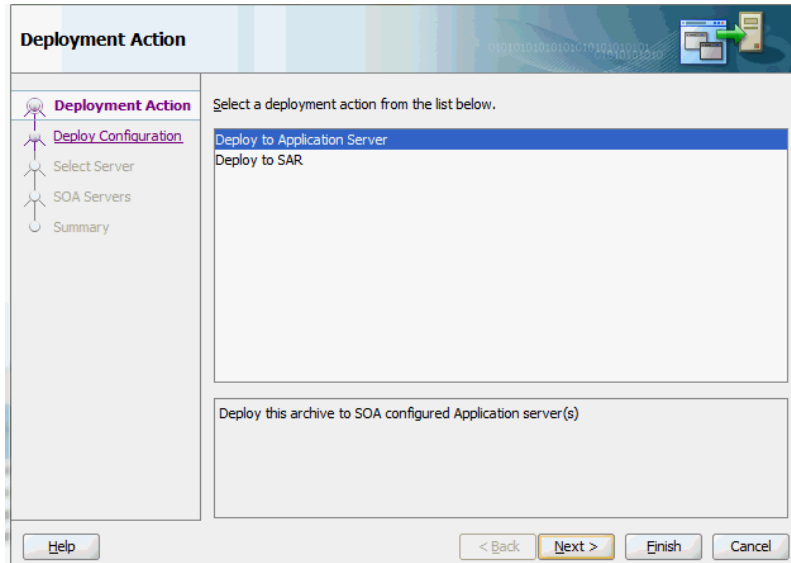

In the Deploy Configuration window, ensure the following information is selected before clicking **Next** to add a new application server:

- New Revision ID: 1.0
- Mark composite revision as default: Select this check box.
- Overwrite any existing composites with the same revision ID: Select this check box.

The steps to create a new Oracle WebLogic Server connection from JDeveloper are covered in [Creating an Application Server Connection](#), page A-12.

3. In the Select Server page, select 'soa-server1' that you have established the server connection earlier. Click **Next**.

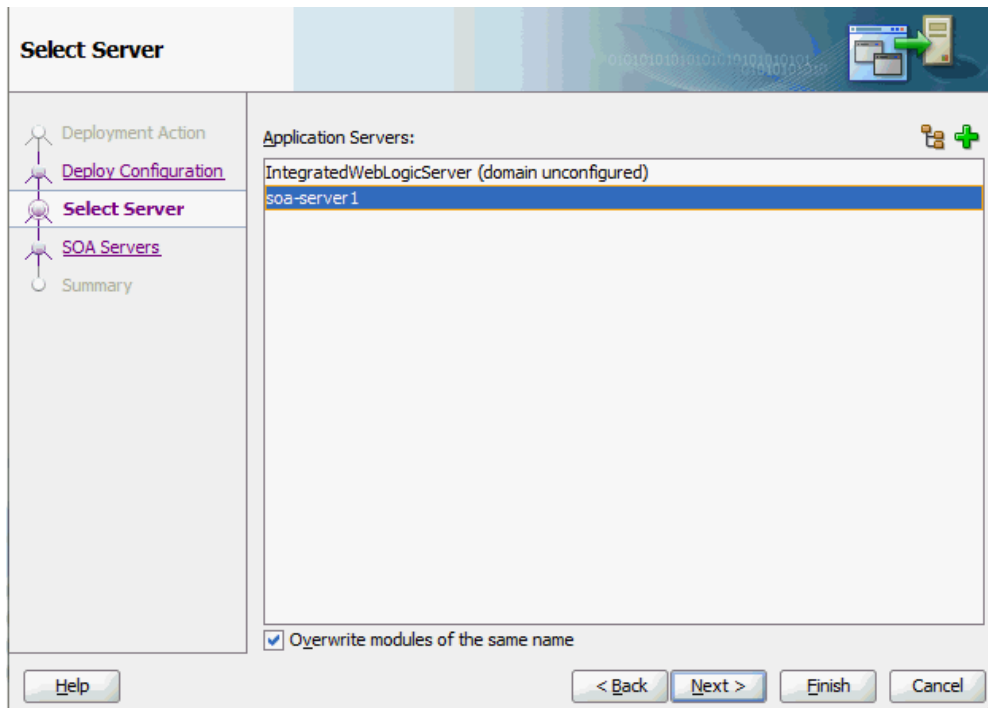

4. In the SOA Servers page, accept the default target SOA Server ('soa-server1') selection.

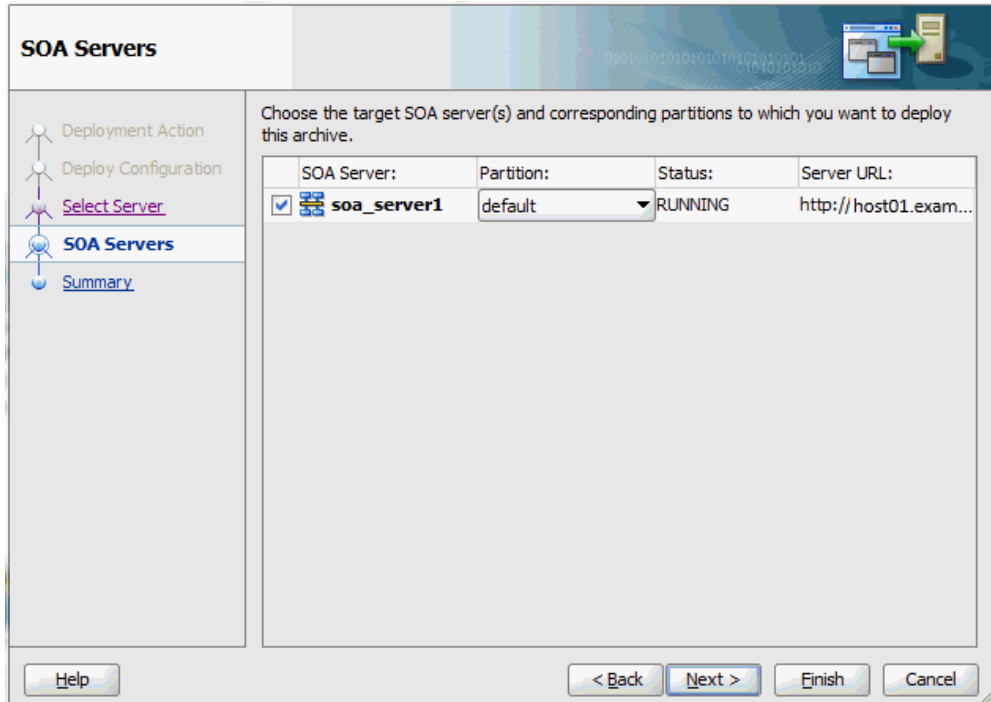

Click **Next** and **Finish**.

If you are deploying the composite for the first time from your Oracle JDeveloper session, the Authorization Request window appears. Enter username and password information specified during Oracle SOA Suite installation. Click **OK**.

5. Deployment processing starts. Monitor deployment progress and check for successful compilation in the SOA - Log window.



Verify that the deployment is successful in the Deployment - Log window.

```

Deployment - Log x
[04:06:09 PM] Sending internal deployment descriptor
[04:06:09 PM] Sending archive - sca_OrderImportConcurrentProgram_rev1.0.jar
[04:06:18 PM] Received HTTP response from the server, response code=200
[04:06:18 PM] Successfully deployed archive sca_OrderImportConcurrentProgram_rev1.0.jar to particio
[04:06:18 PM] Elapsed time for deployment: 25 seconds
[04:06:18 PM] ---- Deployment finished. ----

```

## Testing the Deployed SOA Composite Application with BPEL Process

Once the BPEL process contained in a SOA Composite application is deployed, you can manage and monitor the process from the Oracle Enterprise Manager Fusion Middleware Control Console. You can also test the process and the integration interface by manually initiating the process.

### To test the deployed SOA Composite application with BPEL process:

1. Navigate to Oracle Enterprise Manager Fusion Middleware Control Console (<http://<servername>:<portnumber>/em>). The composite you deployed is displayed in the Applications Navigation tree.

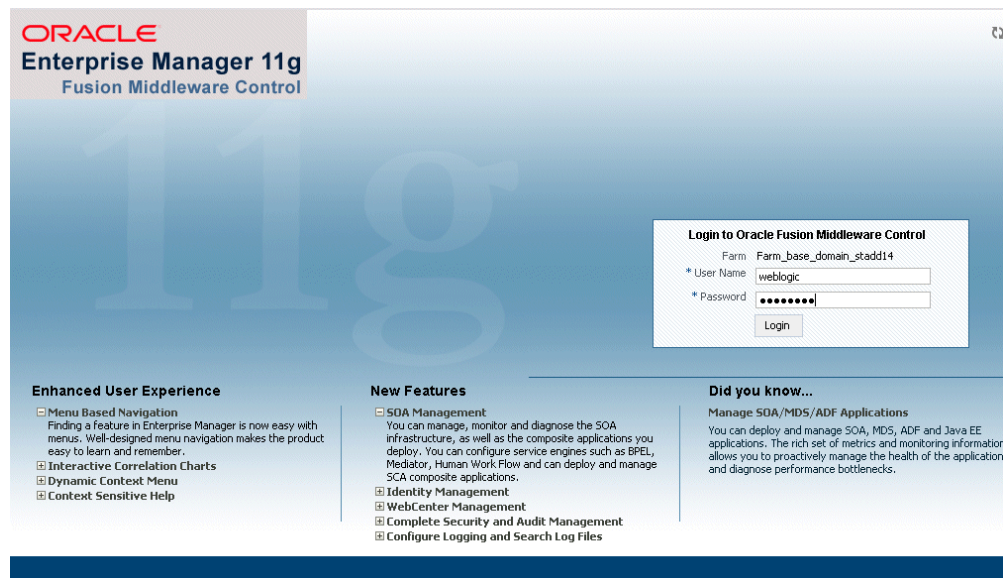

2. Enter username (such as `weblogic`) and password and click **Login** to log in to a farm.

You may need to select an appropriate target instance farm if there are multiple target Oracle Enterprise Manager Fusion Middleware Control Console farms.

3. From the Farm base domain, expand the **SOA >soa-infra** to navigate through the

SOA Infrastructure home page and menu to access your deployed SOA composite applications running in the SOA Infrastructure for that managed server.

**Note:** The Farm menu always displays at the top of the navigator. As you expand the SOA folder in the navigator and click the links displayed beneath it, the SOA Infrastructure menu becomes available at the top of the page.

Click the SOA composite application that you want to initiate (such as 'OrderImportConcurrentProgram') from the SOA Infrastructure.

### Viewing Deployed SOA Composites

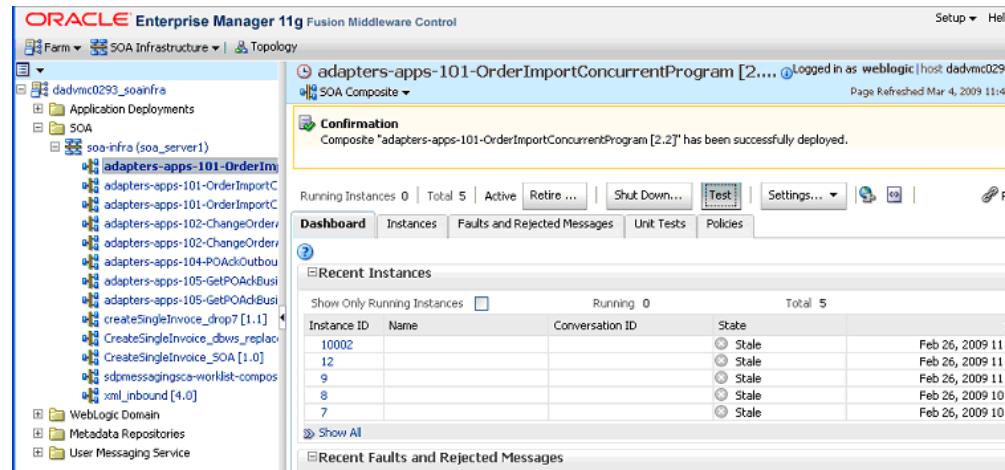

Click **Test** at the top of the page.

4. The Test Web Service page for initiating an instance appears. You can specify the XML payload data to use in the Input Arguments section.

Enter the input string required by the process and click **Test Web Service** to initiate the process.

## Testing Web Service

**Input Arguments**

Tree View

Name	Type	Value
* payload	payload	
* input	string	<input type="text" value="test"/>

Request    Response

Test Web Service

The test results appear in the Response tab upon completion.

- Click on the SOA Composite application name and then select the Instances tab.

The SOA Composite application instance ID, name, conversation ID, most recent known state of each instance since the last data refresh of the page are displayed.

The screenshot shows the Oracle Enterprise Manager 11g Fusion Middleware Control interface. The left pane displays a tree view of the SOA Infrastructure, with the SOA Composite application 'adapters-apps-101-OrderImportConcurrentProgram [2.3]' selected. The right pane shows the 'Instances' tab for this application. A confirmation message at the top states: 'Composite "adapters-apps-101-OrderImportConcurrentProgram [2.3]" has been successfully deployed.' Below this, there are controls for running instances (0 total, 14 active) and buttons for 'Retire...', 'Shut Down...', 'Test', and 'Settings...'. A search section allows filtering by Instance ID, Name, and Conversation ID. At the bottom, a table lists the instances:

Instance ID	Name	Conversation ID	State	Start
50012			---	Mar 5, 2009 12:43:3
50011			State	Mar 5, 2009 12:40:2
50010			State	Mar 5, 2009 12:38:4
30002			State	Mar 3, 2009 2:30:2
30001			State	Mar 3, 2009 1:47:2

In the Instance ID column, click a specific instance ID to show the message flow through the various service components and binding components. The Flow Trace page is displayed.

In the Trace section, you should find the sequence of the message flow for the

service binding component (`orderimportconcurrentprogram_client_ep`), BPEL component (`OrderImportConcurrentProgram`), and reference binding components (`getOrderDetails`, `getCPDetails`, `InsertOrder` and `ImportOrderCP`). All involved components have successfully received and processed messages.

Click the Instances tab and then click the latest Instance ID to see the process flow trace.

The Flow Trace page is displayed.

### Flow Trace Page

**Flow Trace** Data Refreshed Mar 5, 2009 12:46:46 AM

This page shows the flow of the message through various composite and component instances. ECID: 0000HzLnKdt5uXApJ~1Fif19f\_9n00001Q:46  
Started: Mar 5, 2009 12:43:34 AM

**Faults**  
Select a fault to locate it in the trace view.

Error Message	Recovery	Fault Time	Fault Location	Composite Instance
No faults found				

**Trace**  
Click a component instance to see its detailed audit trail.  
Show Instance IDs

Instance	Type	State	Time	Composite Instance
orderimportconcurrentprogram_client_ep	Service	Completed	Mar 5, 2009 12:43:34 AM	adapters-apps-101-Orde
OrderImportConcurrentProgram	BPEL Component	Completed	Mar 5, 2009 12:43:36 AM	adapters-apps-101-Orde
getOrderDetails	Reference	Completed	Mar 5, 2009 12:43:34 AM	adapters-apps-101-Orde
getCPDetails	Reference	Completed	Mar 5, 2009 12:43:34 AM	adapters-apps-101-Orde
InsertOrder	Reference	Completed	Mar 5, 2009 12:43:35 AM	adapters-apps-101-Orde
ImportOrderCP	Reference	Completed	Mar 5, 2009 12:43:36 AM	adapters-apps-101-Orde

If any error occurred during the test, you should find it in the Faults section.

- Click your BPEL service component instance link (such as `OrderImportConcurrentProgram`) to display the Instances page where you can view execution details for the BPEL activities in the Audit Trail tab.

Click the Flow tab to check the BPEL process flow diagram. Click an activity of the process diagram to view the activity details and flow of the payload through the process.

## Verifying Records in Oracle E-Business Suite

To validate the BPEL process, log on to Oracle E-Business Suite forms to check the status of the Concurrent Program execution. Once it is successfully executed, the purchase order should also be created in Oracle E-Business Suite applications.

### To verify records in Oracle E-Business Suite applications:

- Log in to Oracle E-Business Suite with the Order Management Super User, Vision Operations (USA) responsibility.



2. Choose Orders, Return > Sales Order to open the Sales Orders form.

3. Search for an order by pressing **F11** key. In the Customer PO field, enter the order ID present in the xml file. For example, enter `order_id_01` and press **CTRL+F11** keys to execute the query.
4. You should find the newly created order appears with order ID `order_id_01`.  
Select the Line Items tab to verify the quantity and item type of the order which should be the same as that present in the xml file
5. Alternatively, you can also validate the result by querying the database with the following SQL statement:

```
Select orig_sys_document_ref from oe_order_headers_all where
orig_sys_document_ref = 'order_id_01';
```

## Troubleshooting

If you experience problems with your concurrent program integration, you can take the following troubleshooting steps:

- If you're using complex (that is, Boolean) datatypes, ensure that PL/SQL wrappers are applied on the target instance of the concurrent program.
- Examine your transaction data in the Open Interface Tracking Form.

- Check the status of the concurrent programs by Request ID.

Enable logging for Adapter to see if the issue is on the middleware side. How to enable logging for Adapter for Oracle Applications, see [Enabling Logging for Adapters](#), page 4-82.

---

## Using Interface Tables and Views

This chapter covers the following topics:

- Overview of Interface Tables and Views
- Design-Time Tasks for Interface Tables
- Creating a New SOA Composite Application with BPEL Process
- Adding a Partner Link
- Adding a Partner Link for File Adapter
- Configuring Invoke Activities
- Configuring an Assign Activity
- Run-Time Tasks for Interface Tables
- Deploying the SOA Composite Application with BPEL Process
- Testing the Deployed SOA Composite Application with BPEL Process
- Design-Time Tasks for Views
- Creating a New SOA Composite Application with BPEL Process
- Adding a Partner Link
- Adding a Partner Link for File Adapter
- Configuring Invoke Activities
- Configuring an Assign Activity
- Run-Time Tasks for Views
- Deploying the SOA Composite Application with BPEL Process
- Testing the Deployed SOA Composite Application with BPEL Process

## Overview of Interface Tables and Views

Adapter for Oracle Applications uses interface tables to insert and update data in Oracle Applications, and uses interface views to retrieve data from Oracle Applications. This chapter describes the following interfaces:

- Interface Tables
- Interface Views

### Interface Tables

Adapter for Oracle Applications use open interface tables to insert data in Oracle Applications. For example, by using interface tables, you can insert a purchase order into Oracle Applications to generate the sales order automatically. Data is never loaded directly into Oracle Applications base tables. Instead, data is first loaded into interface tables, and then Oracle-supplied concurrent programs move data from interface tables to base tables. This ensures that all business logic and processing is handled using Oracle components.

Adapter for Oracle Applications use open interface tables to integrate with Oracle Applications through direct database access. The Adapter for Oracle Applications inserts data into the open interface tables. These interface tables can be used only for insert operations and support only an inbound connection into Oracle Applications.

Interface tables are intermediate tables into which the data is inserted first. Once the data gets inserted into the interface tables, the data is validated, and then transferred to the base tables. Base tables are real application tables that reside in the application database. The data that resides in the interface tables is transferred to the base tables using concurrent programs. A concurrent program is an instance of an execution file. Concurrent programs are scheduled in Oracle Applications to move data from interface tables to base tables. These programs perform the application-level checks and run validation before inserting data into base tables.

### Views

Adapter for Oracle Applications uses views to retrieve data from Oracle Applications. For example, by using views, you can retrieve information about your customers from the required tables in Oracle Applications.

Adapter for Oracle Applications uses views to retrieve data from Oracle Applications. Views allow only simple definition. By using views, you can get synchronous data access to Oracle Applications. In Adapter for Oracle Applications, views are created on base tables as well as interface tables. These views can be used *only* for select operations.

In the Oracle Applications 11.5.10 release, you cannot work on multiple views. A work around to address this would be to create a view that spans multiple views.

## Design-Time Tasks for Interface Tables

This section describes how to configure the Adapter for Oracle Applications to use interface tables. It describes the steps to configure Adapter for Oracle Applications using the Adapter Configuration Wizard in Oracle JDeveloper.

### SOA Composite Application with BPEL Process Scenario

Take Open Interface tables (OE\_HEADER\_IFACE\_ALL and OE\_LINES\_IFACE\_ALL) as examples.

When a request of inserting order data into Open Interface tables is received, order details will be retrieved through synchronous read operation from an input file and then inserted into Open Interface tables (OE\_HEADER\_IFACE\_ALL and OE\_LINES\_IFACE\_ALL).

When the SOA Composite application with BPEL process has been successfully executed after deployment, you can validate the result by fetching the inserted data using SQL statement.

### Prerequisites to Configure Interface Tables

- Define primary keys on all the interface tables being used.
- Define parent-child relationships among all the selected interface tables.

### SOA Composite Application with BPEL Process Flow

Following is a list of the procedures required to accomplish the design-time tasks.

1. Create a new SOA Composite application with BPEL process, page 8-3
2. Add a partner link, page 8-7
3. Add a partner link for File Adapter, page 8-23
4. Configure the Invoke activities, page 8-27
5. Configure the Assign activity, page 8-30

## Creating a New SOA Composite Application with BPEL Process

### To create a new SOA Composite application with BPEL process:

1. Open JDeveloper BPEL Designer. Click **New Application** in the Application Navigator.

The Create SOA Application - Name your application page is displayed.

### The Create SOA Application - Name your application Page

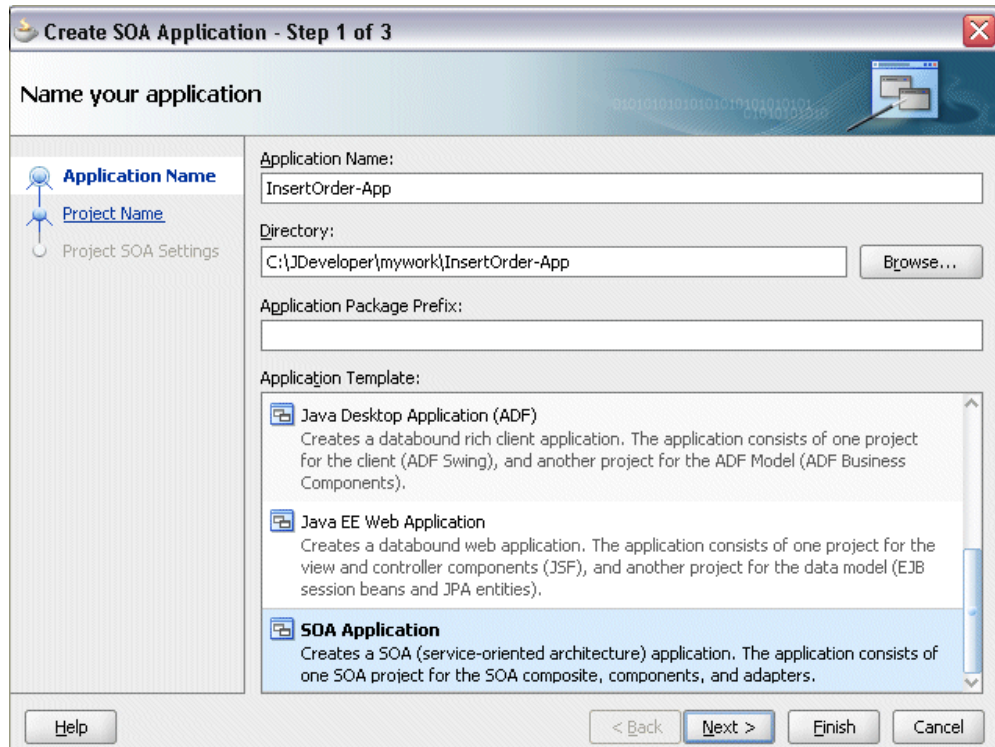

2. Enter an appropriate name for the application in the **Application Name** field and select **SOA Application** from the Application Template list.

Click **Next**. The Create SOA Application - Name your project page is displayed.

3. Enter an appropriate name for the project in the **Project Name** field. For example, `InsertOrder`.

### The Create SOA Application - Name your project Page

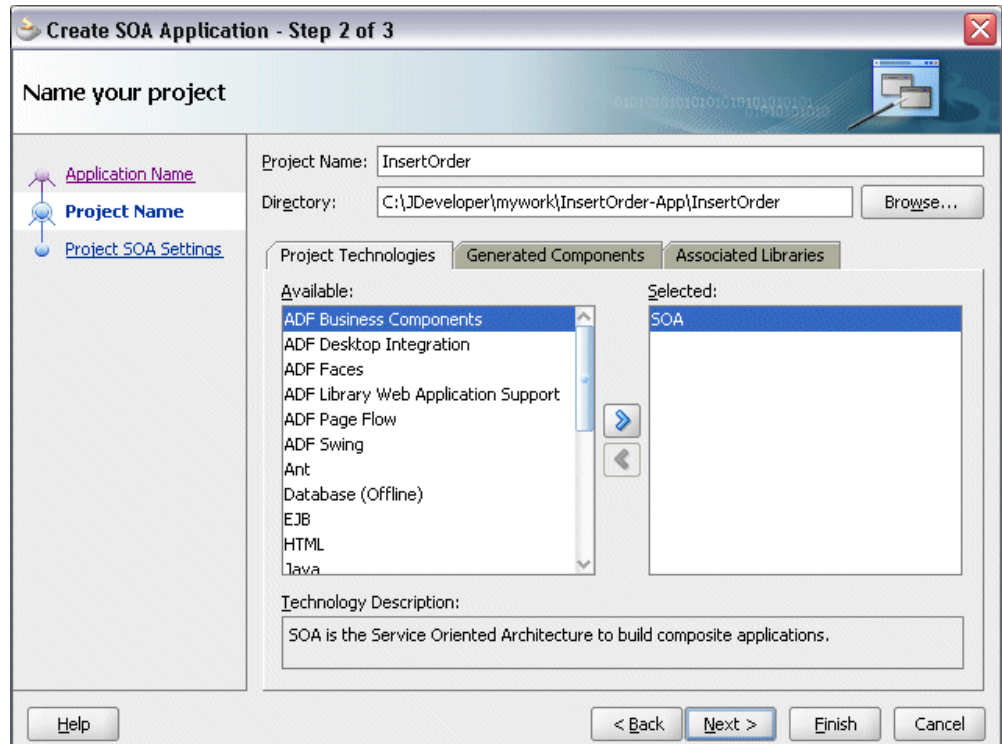

4. In the Project Technologies tab, ensure that **SOA** is selected from the Available technology list to the Selected technology list.

Click **Next**. The Create SOA Application - Configure SOA settings page is displayed.

### The Create SOA Application - Configure SOA settings Page

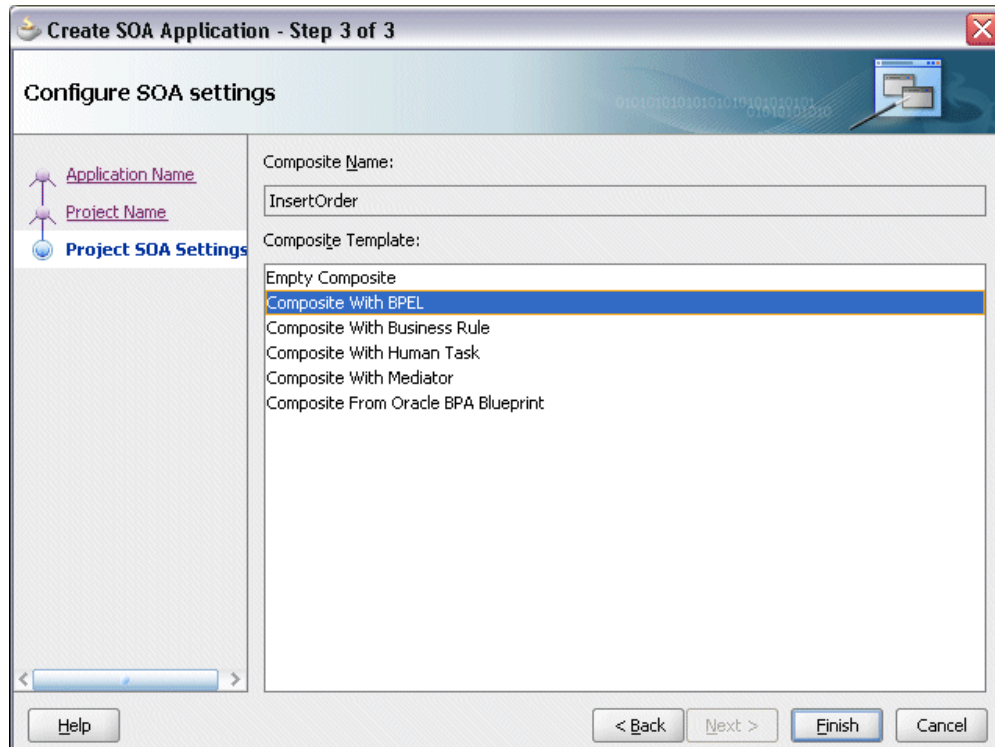

5. In the **BPEL Process Name** field, enter a descriptive name. For example, `InsertOrder`.
6. Select **Composite With BPEL** from the Composite Template list, and then click **Finish**. You have created a new application, and a SOA project. This automatically creates a SOA composite.

The Create BPEL Process page is displayed.

7. Leave the default **BPEL 1.1 Specification** selection unchanged. This creates a BPEL project that supports the BPEL 1.1 specification.

Enter an appropriate name for the BPEL process in the **Name** field. For example, `InsertOrder`.

Select **Asynchronous BPEL Process** in the **Template** field. Click **OK**.

An asynchronous BPEL process is created with the Receive and Reply activities. The required source files including `bpel` and `wSDL`, using the name you specified (for example, `InsertOrder.bpel` and `InsertOrder.wSDL`) and `composite.xml` are also generated.



## Adding a Partner Link

This section describes how to add a partner link to your BPEL process. A partner link defines the link name, type, and the role of the BPEL process that interacts with the partner service.

### To add a partner link to insert order details into selected Open Interface tables:

1. Click **BPEL Services** in the Component Palette.

Drag and drop **Oracle Applications** from the **BPEL Services** list into the right Partner Link swim lane of the process diagram. The Adapter Configuration Wizard Welcome page appears. Click **Next**.

2. Enter a service name in the **Service Name** field. For example, `InsertOrder`. Click **Next**. The Service Connection dialog appears.

### Specifying a Database Service Connection

The screenshot shows a window titled "Adapter Configuration Wizard - Step 3 of 4" with a close button in the top right corner. The main heading is "Service Connection". Below the heading, there is a blue banner with a gear icon and binary code. The text reads: "A Database Connection is required to configure this adapter. Select a database connection already defined in your project or create a New Connection." Below this, there is a "Connection:" dropdown menu with "OracleAppsConnection" selected. To the right of the dropdown are three icons: a green plus sign, a pencil, and a key. Below the dropdown, the following information is displayed: "User Name: apps", "Driver: oracle.jdbc.OracleDriver", and "Connect String: jdbc:oracle:thin:@localhost:1521:sid01". Below this, there is a note: "Specify the JNDI name for the database. Note: The deployment descriptor of the Oracle Applications adapter must associate this JNDI name with configuration properties required by the adapter to access the database." Below the note is a "JNDI Name:" label and a text input field containing "eis/Apps/OracleAppsConnection". At the bottom of the window, there are four buttons: "Help", "< Back", "Next >", "Finish", and "Cancel".

3. You can perform either one of the following options for your database connection:

**Note:** You need to connect to the database where Oracle Applications is running.

- You can create a new database connection by clicking the **Create a New Database Connection** icon.

How to define a new database connection, see *Create a New Database Connection*, page 5-13.

- You can select an existing database connection that you have configured earlier from the **Connection** drop-down list.

The Service Connection page will be displayed with the selected connection information. The JNDI (Java Naming and Directory Interface) name corresponding to the database connection appears automatically in the **Database Server JNDI Name** field. Alternatively, you can specify a JNDI name.

**Note:** When you specify a JNDI name, the deployment descriptor of the Oracle Applications adapter must associate this JNDI name with configuration properties required by the adapter to access the database.

The JNDI name acts as a placeholder for the connection used when your service is deployed to the BPEL server. This enables you to use different databases for development and later for production.

**Note:** For more information about JNDI concepts, refer to *Oracle Fusion Middleware User's Guide for Technology Adapters*.

4. Click **Next** in the Service Connection dialog box. You can add an interface table by browsing through the list of interface tables available in Oracle Applications.

**For Oracle E-Business Suite Release 12:**

If you are connecting to Oracle E-Business Suite Release 12, then the **IREP File not present** dialog box appears indicating that Adapter could not find the Oracle Integration Repository data file corresponding to the database you are connecting in your workspace. Absence of the data file would make browsing or searching of Integration Repository tree considerably slow. You can choose to extract the data file and create a local copy of the Integration Repository data file. Once it is created successfully, Adapter will pick it up automatically next time and retrieve data from your local Integration Repository.

You can select one of the following options:

- Click **Yes** to extract the Integration Repository data file.

### Extracting Integration Repository Data File

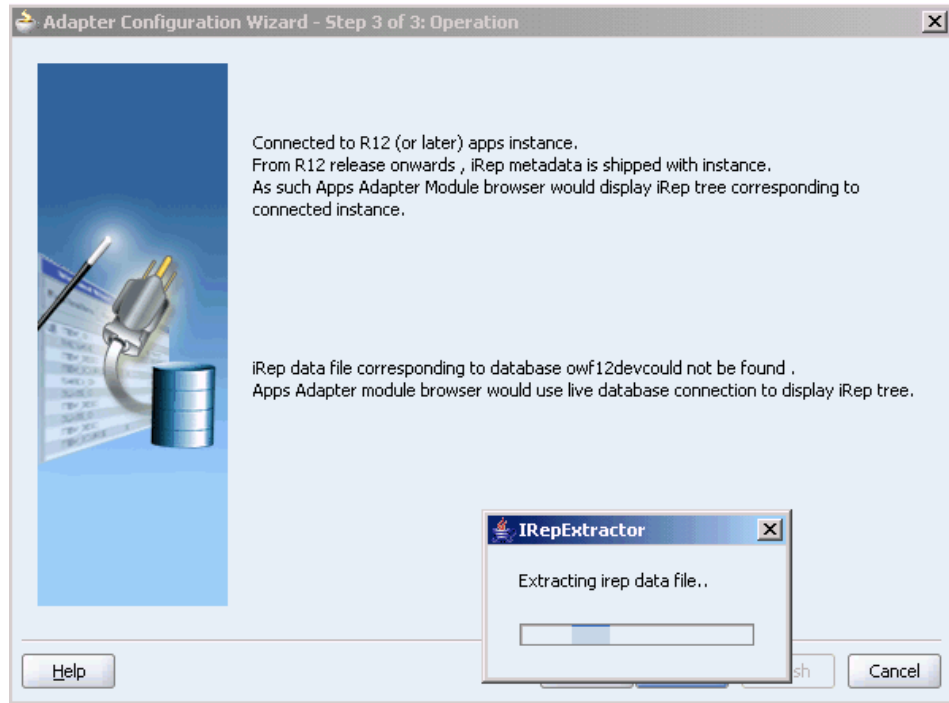

After the system successfully creates a local copy of the Integration Repository data file, next time when you connect to the database, you will find the **IRep Data File** field appears in the Operation dialog box indicating where your local copy exists with the creation date and time as part of the file name.

### Using the Local Integration Repository Data File

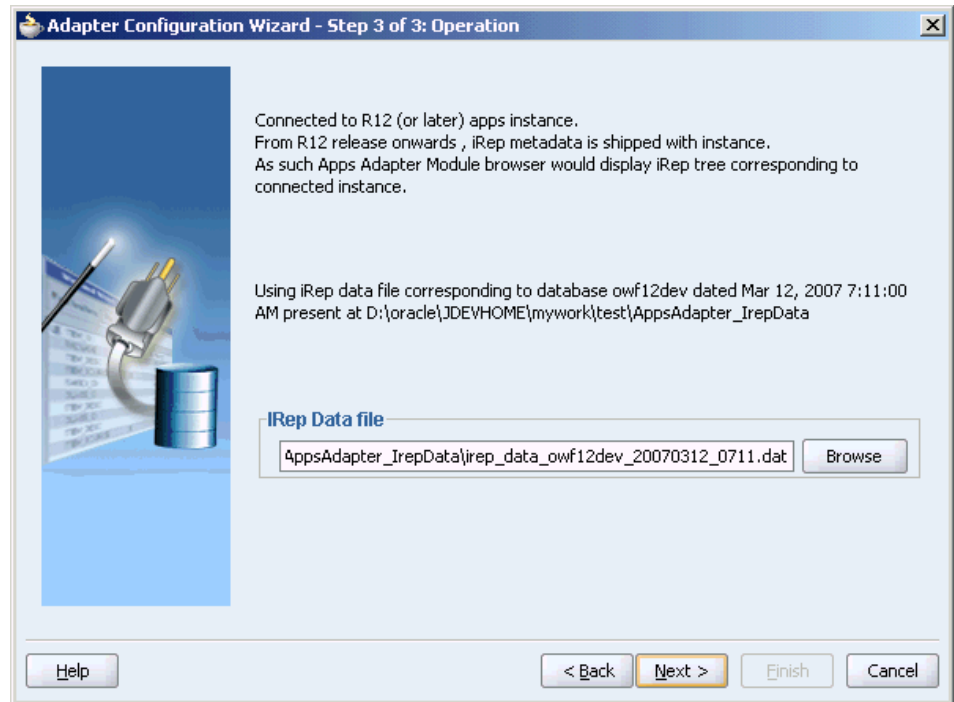

- Click **No** to query the Integration Repository data file from the live database you are connecting to display the Integration Repository tree.

#### For Oracle E-Business Suite Release 11.5.9:

If you are connecting to an Oracle E-Business Suite Release 11.5.9 instance, you must select the interface type in the Adapter Configuration Wizard. Select **Tables/Views/APIs/Concurrent Programs** to proceed.

5. Click **Get Object** to open the Oracle Applications Module Browser.

## Selecting a Concurrent Program from the Module Browser

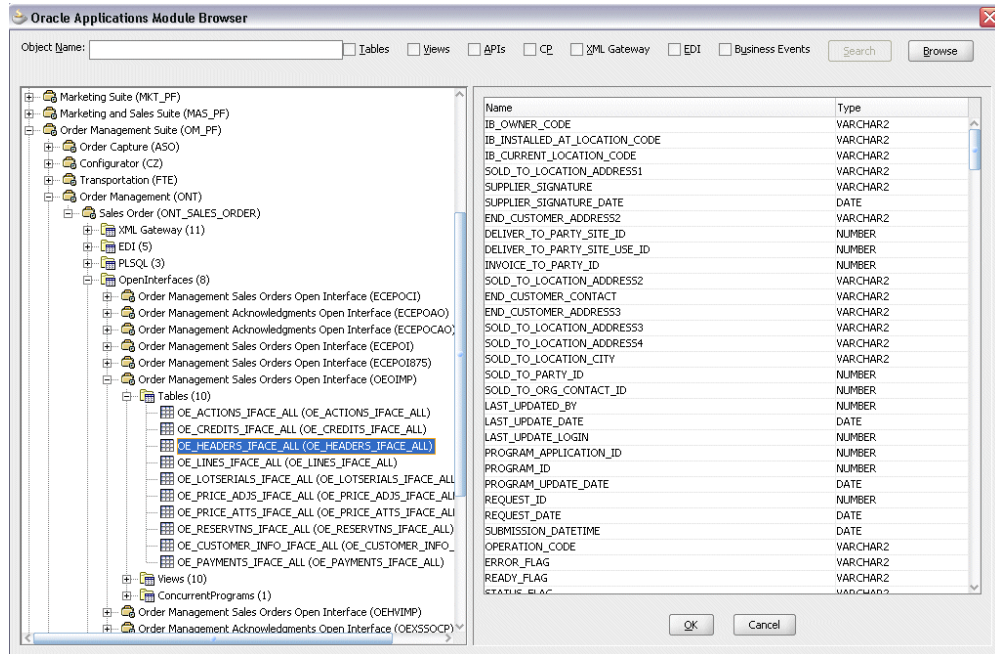

Oracle Applications Module Browser includes the various product families that are available in Oracle Applications. For example, Applications Technology or Order Management Suite are product families in Oracle Applications. The product families contain the individual products. For example, Order Management Suite contains the Order Management product. The individual products contain the business entities associated with the product. For example, the Order Management product contains the Sales Order business entity.

Business entities contain the various application modules that are exposed for integration. These modules are grouped according to the interface they provide. concurrent programs can be found under the Open Interfaces category.

6. Navigate to *Order Management Suite (OM\_PF) > Order Management (ONT) > Sales Order (ONT\_SALES\_ORDER) > OpenInterfaces > Order Management Sales Orders Open Interface (OEOIMP) > Tables* to select `OE_HEADERS_IFACE_ALL`.

**Note:** You can also search for a table by entering the name of the program in the **Object Name** field. Select the **Tables** check box, then click **Search**.

Click **OK**. The Application Interface page appears with the selected open table.

### Adapter Configuration Wizard - Application Interface Page

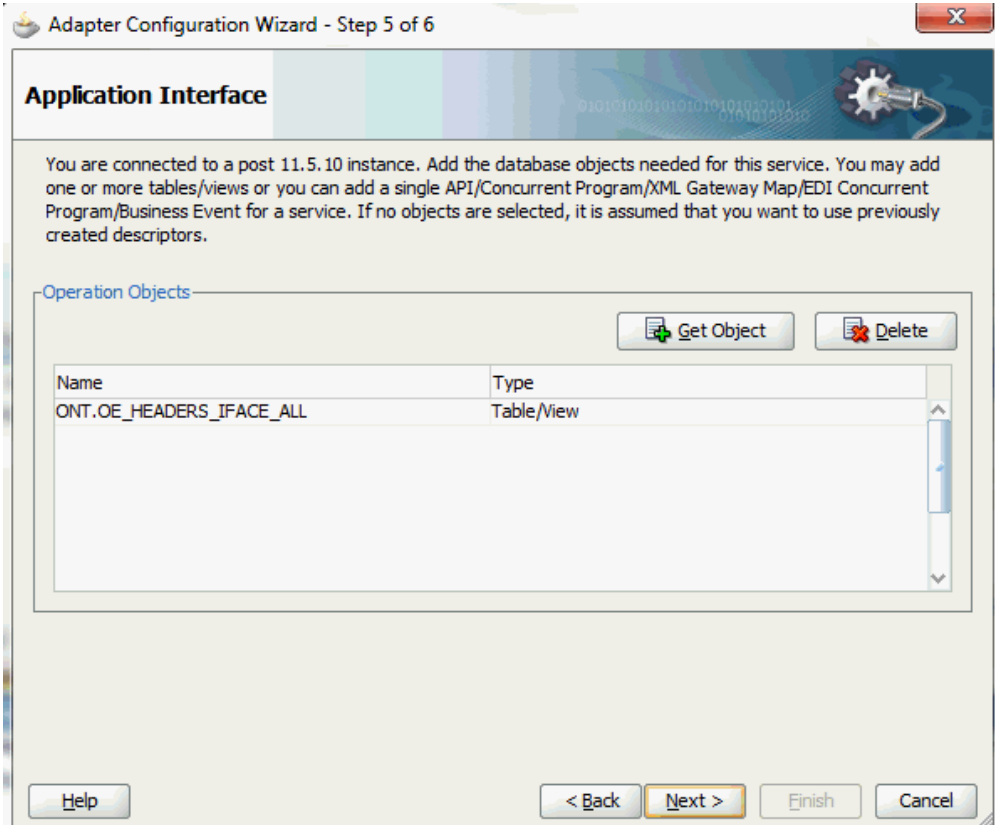

7. Click **Get Object** to open the Oracle Applications Module Browser again to select another open interface table `OE_LINES_IFACE_ALL` using the same navigation path *Order Management Suite (OM\_PF) > Order Management (ONT) > Sales Order (ONT\_SALES\_ORDER) > OpenInterfaces > Order Management Sales Orders Open Interface (OEOIMP) > Tables*.

Click **OK**. The Application Interface page appears with the two selected tables.

## Adapter Configuration Wizard - Application Interface Page

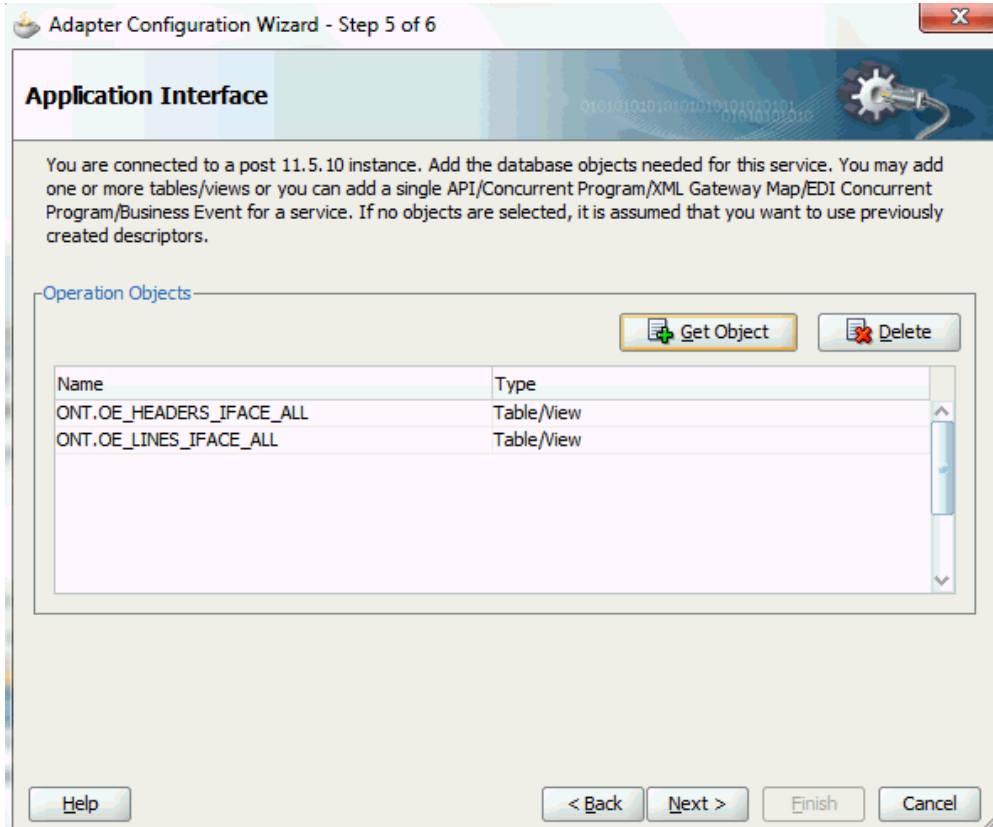

Click **OK**.

8. Click **Next**. The Operation Type page is displayed.



### Adapter Configuration Wizard - Operation Type Page

Adapter Configuration Wizard - Step 6 of 7

## Operation Type

Select the Operation Type and click Next to continue defining the operation.

Operation Type:  Perform an Operation on a Table

- Insert
- Select
- Select By Primary Key

Poll for New or Changed Records in a Table

Do Synchronous Post to BPEL (Allows In-Order Delivery)

Cache Usage: none (default) ▼

Help < Back Next > Finish Cancel

Select the **Perform an Operation on a Table** radio button and then choose the **Insert** check box. Ensure that the **Select** check box is deselected.

9. Click **Next**. The Select Table page appears which displays the tables that have been previously imported in this JDeveloper project (including tables that were imported for other partner links). This enables you to reuse configured table definitions in multiple partner links.

### Adapter Configuration Wizard - Select Table Page

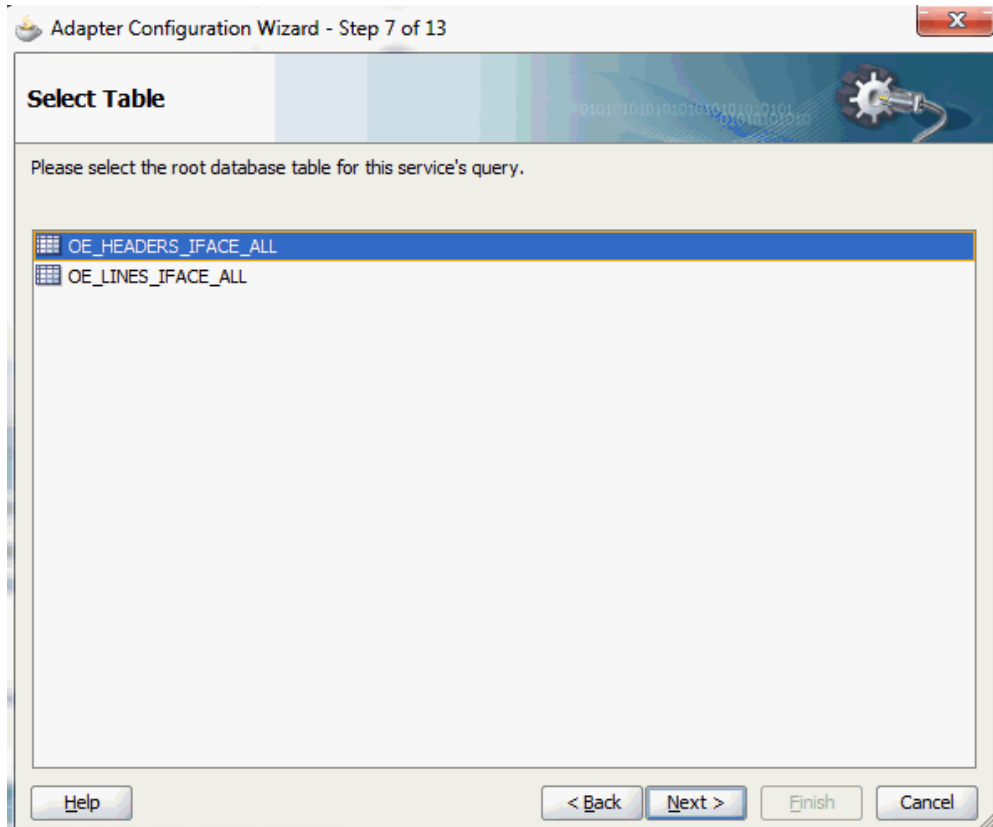

Select OE\_HEADERS\_IFACE\_ALL as the root database table for this service's query.

10. Click Next. The Define Primary Keys page is displayed.

**Adapter Configuration Wizard - Define Primary Keys Page for  
OE\_HEADERS\_IFACE\_ALL**

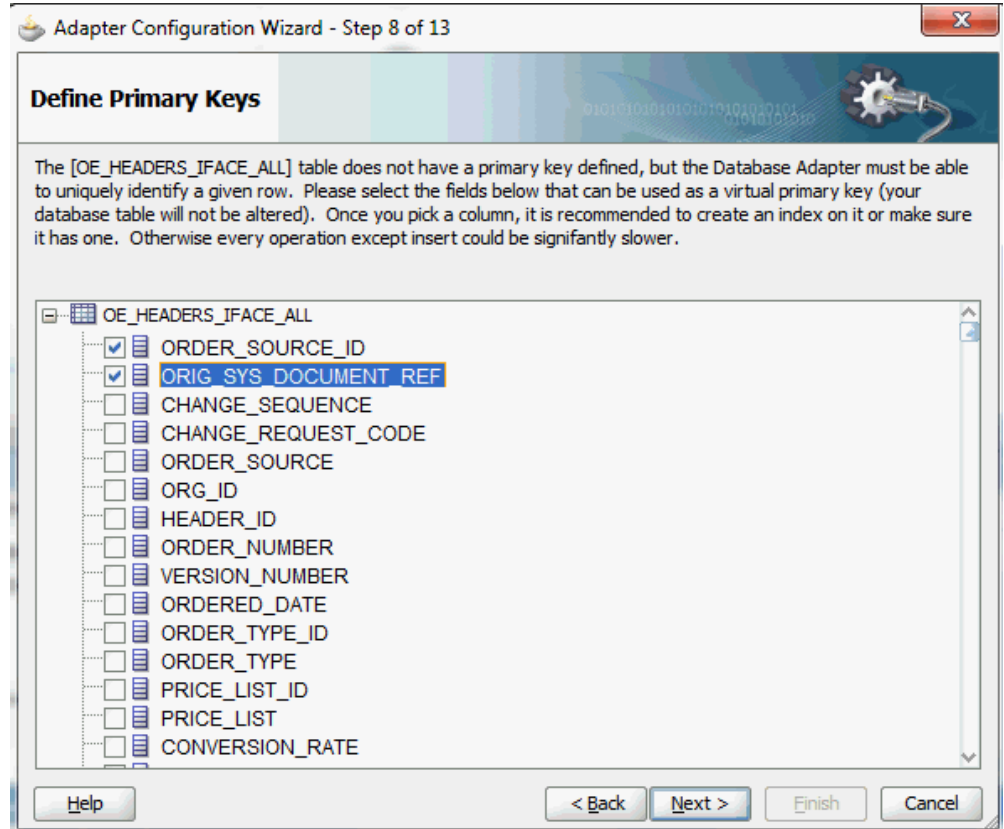

Select the following primary keys for the OE\_HEADERS\_IFACE\_ALL table:

- ORDER\_SOURCE\_ID
- ORIG\_SYS\_DOCUMENT\_REF

Click **Next**.

Select the same primary keys for the OE\_LINES\_IFACE\_ALL table.

## Adapter Configuration Wizard - Define Primary Keys Page for OE\_LINES\_IFACE\_ALL

Adapter Configuration Wizard - Step 9 of 13

### Define Primary Keys

The [OE\_LINES\_IFACE\_ALL] table does not have a primary key defined, but the Database Adapter must be able to uniquely identify a given row. Please select the fields below that can be used as a virtual primary key (your database table will not be altered). Once you pick a column, it is recommended to create an index on it or make sure it has one. Otherwise every operation except insert could be significantly slower.

Field Name	Selected
ORDER_SOURCE_ID	<input checked="" type="checkbox"/>
ORIG_SYS_DOCUMENT_REF	<input checked="" type="checkbox"/>
ORIG_SYS_LINE_REF	<input type="checkbox"/>
ORIG_SYS_SHIPMENT_REF	<input type="checkbox"/>
CHANGE_SEQUENCE	<input type="checkbox"/>
CHANGE_REQUEST_CODE	<input type="checkbox"/>
ORG_ID	<input type="checkbox"/>
LINE_NUMBER	<input type="checkbox"/>
SHIPMENT_NUMBER	<input type="checkbox"/>
LINE_ID	<input type="checkbox"/>
SPLIT_FROM_LINE_ID	<input type="checkbox"/>
LINE_TYPE_ID	<input type="checkbox"/>
LINE_TYPE	<input type="checkbox"/>
ITEM_TYPE_CODE	<input type="checkbox"/>
INVENTORY_ITEM_ID	<input type="checkbox"/>

Buttons: Help, < Back, Next >, Finish, Cancel

11. Click **Next**. The Relationships page appears. Click **Create** to open the Create Relationship dialog.

## Defining Relationships

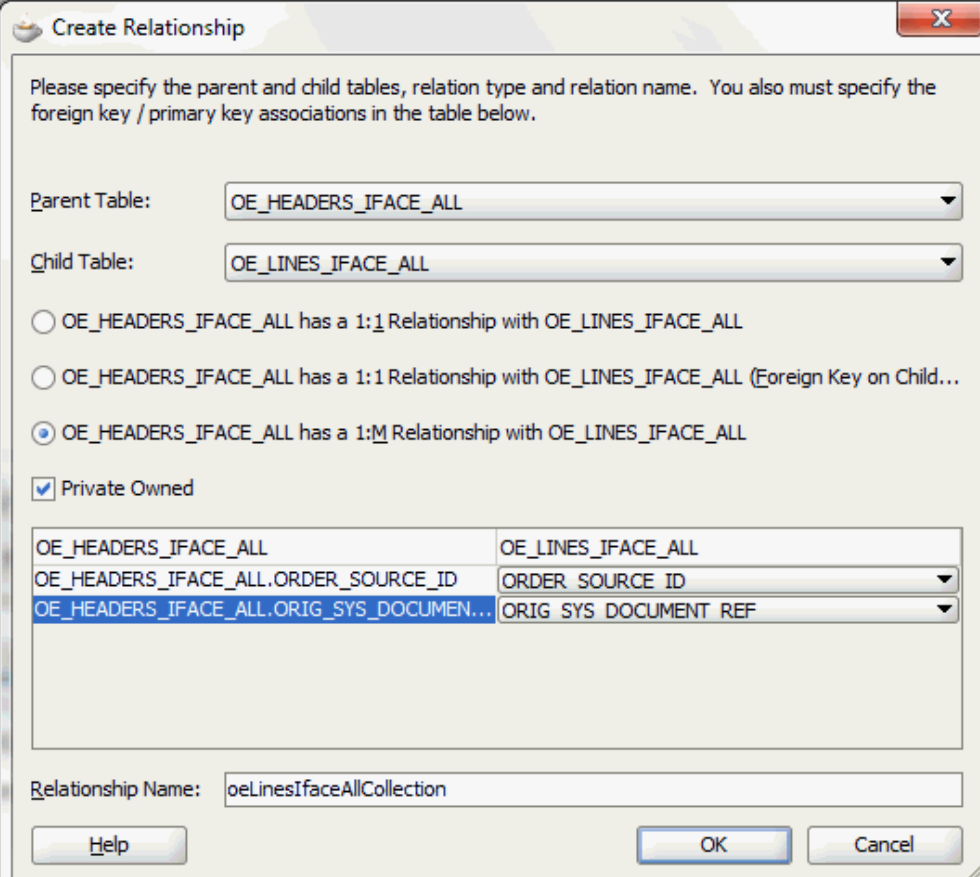

Please specify the parent and child tables, relation type and relation name. You also must specify the foreign key / primary key associations in the table below.

Parent Table: OE\_HEADERS\_IFACE\_ALL

Child Table: OE\_LINES\_IFACE\_ALL

OE\_HEADERS\_IFACE\_ALL has a 1:1 Relationship with OE\_LINES\_IFACE\_ALL

OE\_HEADERS\_IFACE\_ALL has a 1:1 Relationship with OE\_LINES\_IFACE\_ALL (Foreign Key on Child...

OE\_HEADERS\_IFACE\_ALL has a 1:M Relationship with OE\_LINES\_IFACE\_ALL

Private Owned

OE_HEADERS_IFACE_ALL	OE_LINES_IFACE_ALL
OE_HEADERS_IFACE_ALL.ORDER_SOURCE_ID	ORDER_SOURCE_ID
OE_HEADERS_IFACE_ALL.ORIG_SYS_DOCUMENT...	ORIG_SYS_DOCUMENT_REF

Relationship Name: oeLinesIfaceAllCollection

Help OK Cancel

Enter the following information to define the relationship between the header and the detail table:

- Select the OE\_HEADERS\_IFACE\_ALL as the parent table and OE\_LINES\_IFACE\_ALL as the child table.
- Select the mapping type: OE\_HEADERS\_IFACE\_ALL has a 1:M Relationship with OE\_LINES\_IFACE\_ALL

**Note:** If foreign key constraints between tables already exist in the database, then two relationships are created automatically while importing tables. One of the relationships is 1:M relationship from the source table, which is the table containing the foreign key constraints, to the target table. The other relationship is a 1:1 back pointer from the target table to the source table.

- Select the **Private Owned** check box.
- Associate the foreign key fields with the primary key fields:
  - OE\_HEADERS\_IFACE\_ALL.ORDER\_SOURCE\_ID: ORDER\_SOURCE\_ID
  - OE\_HEADERS\_IFACE\_ALL.ORIG\_SYS\_DOCUMENT\_REF:  
ORIG\_SYS\_DOCUMENT\_REF
- The Relationship Name field is populated automatically by default. You can optionally specify a new name for the relationship you are creating.

Click **OK**. The newly created relationship information appears in the Relationships page.

## Adapter Configuration Wizard - Relationships Page

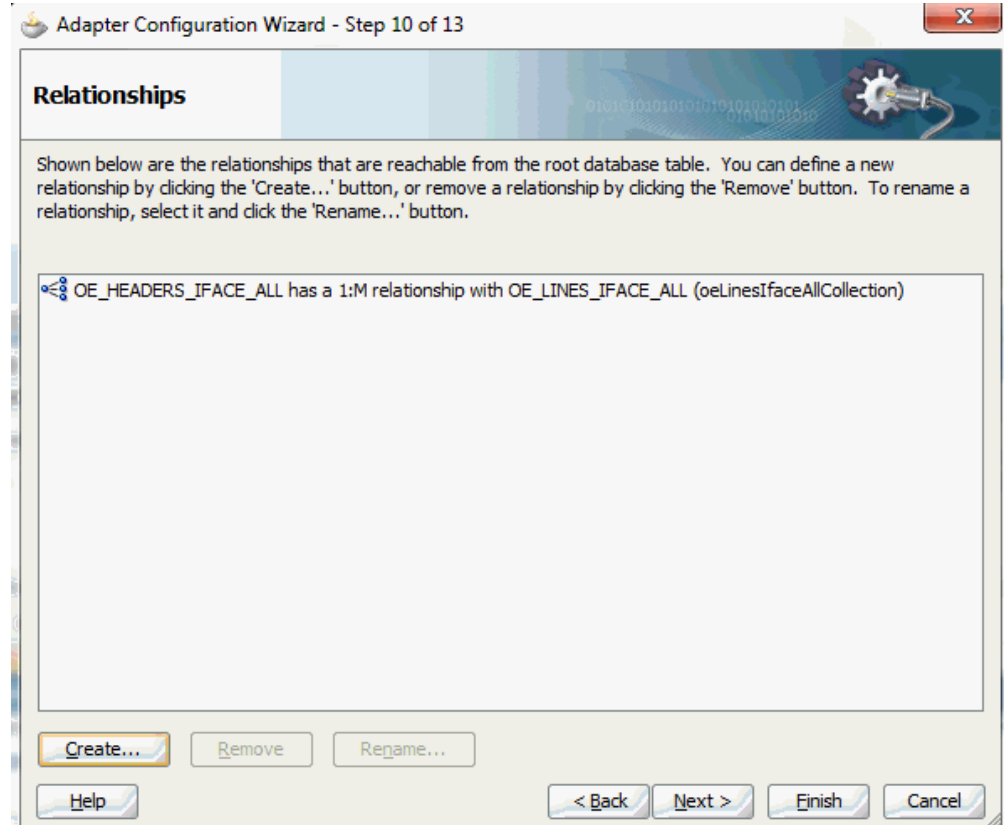

12. Click **Next**. The Attribute Filtering page appears. Leave default selections unchanged.

## Adapter Configuration Wizard - Attribute Filtering Page

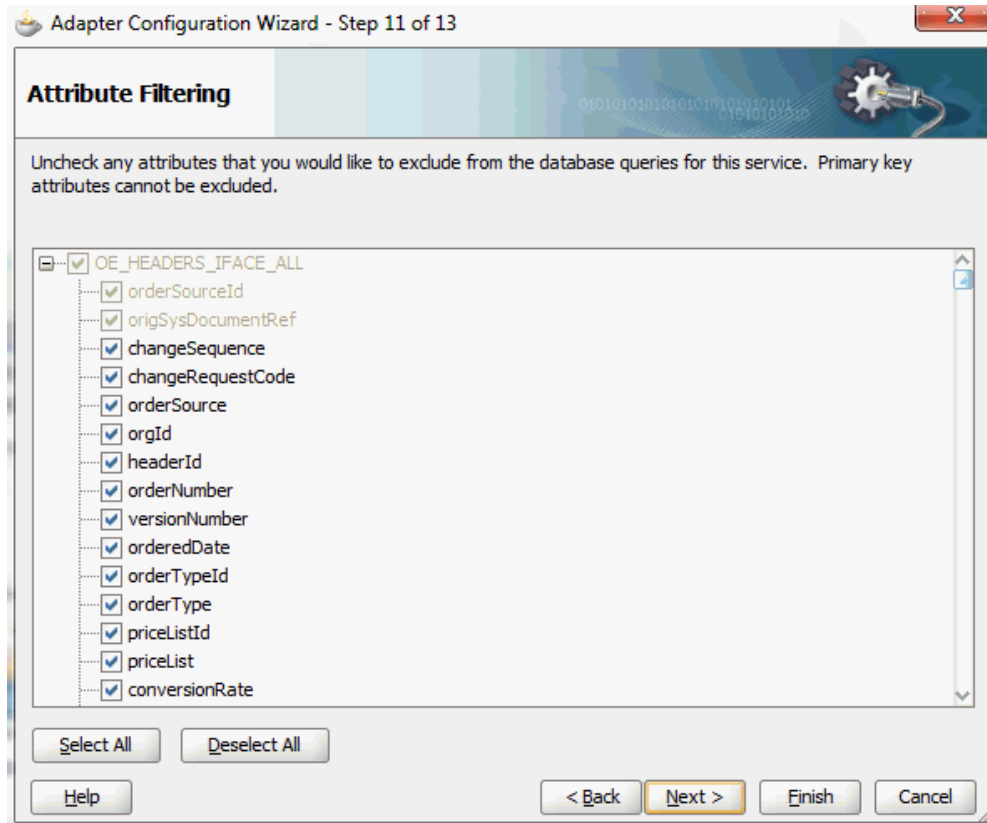

Click **Next**. The Advanced Options page appears.

Click **Next**.

13. Click **Finish**. The wizard generates the WSDL file corresponding to the selected interface. This WSDL file is now available for the partner link.



### Completing the Partner Link Configuration

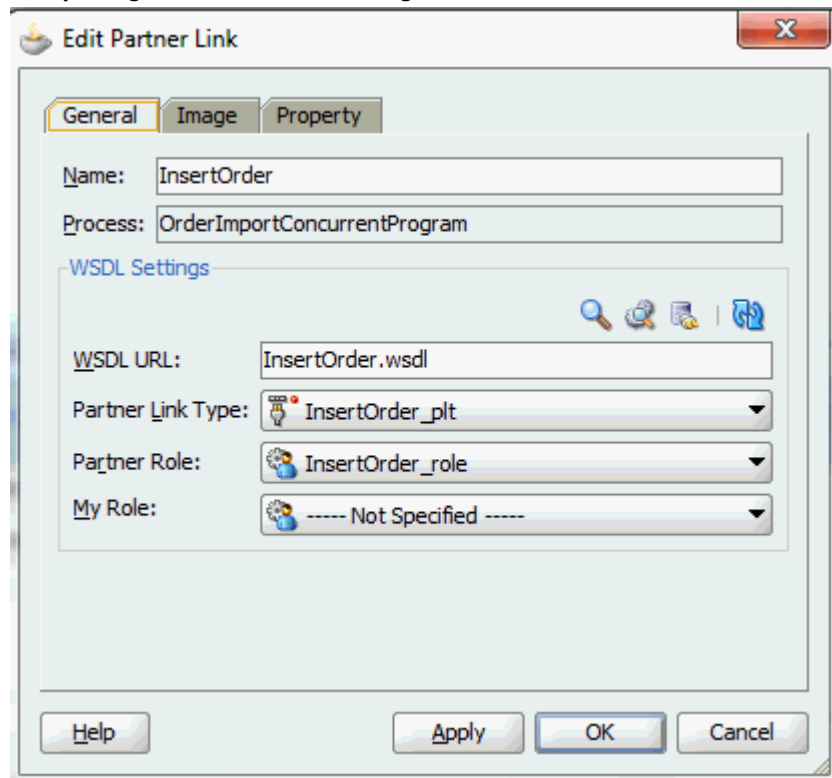

14. Click **Apply** and then **OK**. The partner link is created with the required WSDL settings.

## Adding a Partner Link for File Adapter

Use this step to configure a BPEL process by synchronously reading payload from an input file to obtain the purchase order details.

### To add a Partner Link for File Adapter to read order details:

1. In Oracle JDeveloper BPEL Designer, click **BPEL Services** in the Component palette.

Drag and drop **File Adapter** from the **BPEL Services** list into the right Partner Link swim lane before the first partner link `InsertOrder`. The Adapter Configuration Wizard Welcome page appears.

Click **Next**.

2. In the Service Name dialog, enter a name for the File Adapter service, such as `getOrderDetails`.

3. Click **Next**. The Adapter Interface page appears.

### Specifying the Adapter Interface

The screenshot shows a window titled "Adapter Configuration Wizard - Step 3 of 4" with a close button in the top right corner. The main heading is "Adapter Interface". Below the heading is a descriptive paragraph: "The adapter interface is defined by a wsdl that is generated using the operation name and schema(s) specified later in this wizard. Optionally, the adapter interface may be defined by importing an existing WSDL." Under the heading "Interface:", there are two radio buttons. The first, "Define from operation and schema (specified later)", is selected and highlighted with a yellow box. The second is "Import an existing WSDL". Below these are three input fields: "WSDL URL:" with a text box and a file icon, "Port Type:" with a dropdown menu, and "Operation:" with a dropdown menu. At the bottom of the window are four buttons: "Help", "< Back", "Next >" (which is highlighted in blue), and "Finish" and "Cancel".

Select the **Define from operation and schema (specified later)** radio button and click **Next**.

4. In the Operation page, specify the operation type. For example, select the **Synchronous Read File** radio button. This automatically populates the **Operation Name** field.

### Specifying the Operation

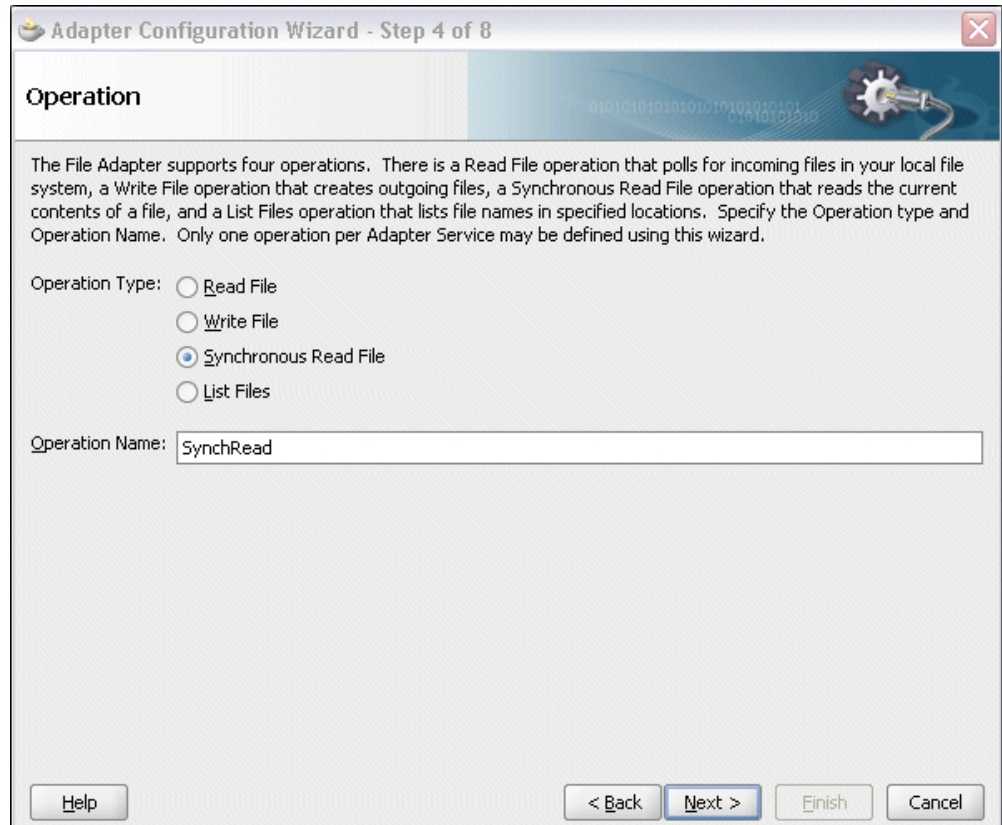

Click **Next** to access the File Directories page.

5. Select the **Logical Name** radio button and specify directory for incoming files, such as `inputDir`.

Ensure the **Delete files after successful retrieval** check box is not selected.

### Configuring the Input File

The screenshot shows a window titled "Adapter Configuration Wizard - Step 5 of 8" with a close button in the top right corner. The main heading is "File Directories". Below the heading, there is a text box with the instruction: "Enter directory information for the incoming file of the Synchronous Read File operation." Below this, there are two radio buttons: "Physical Path" (unselected) and "Logical Name" (selected). There are three input fields, each with a "Browse" button to its right. The first input field is labeled "Directory for Incoming Files (physical path):" and contains the text "inputDir". The second input field is labeled "Archive Directory for Processed Files (physical path):" and is empty. The third input field is labeled "Delete files after successful retrieval" and is empty. At the bottom of the window, there are four buttons: "Help", "< Back", "Next >", and "Finish", followed by a "Cancel" button.

Click **Next** to open the File Name page.

6. Enter the name of the file for the synchronous read file operation. For example, enter `order_data.xml`. Click **Next** to open the Messages page.
7. Select the 'browse for schema file' icon next to the URL field to open the Type Chooser.

Click Type Explorer and select *Project Schema Files > InsertOrder\_table.xsd > OeHeadersIfaceAllCollection*. Click **OK**.

The selected schema information will be automatically populated in the URL and Schema Element fields.

## Specifying Message Schema

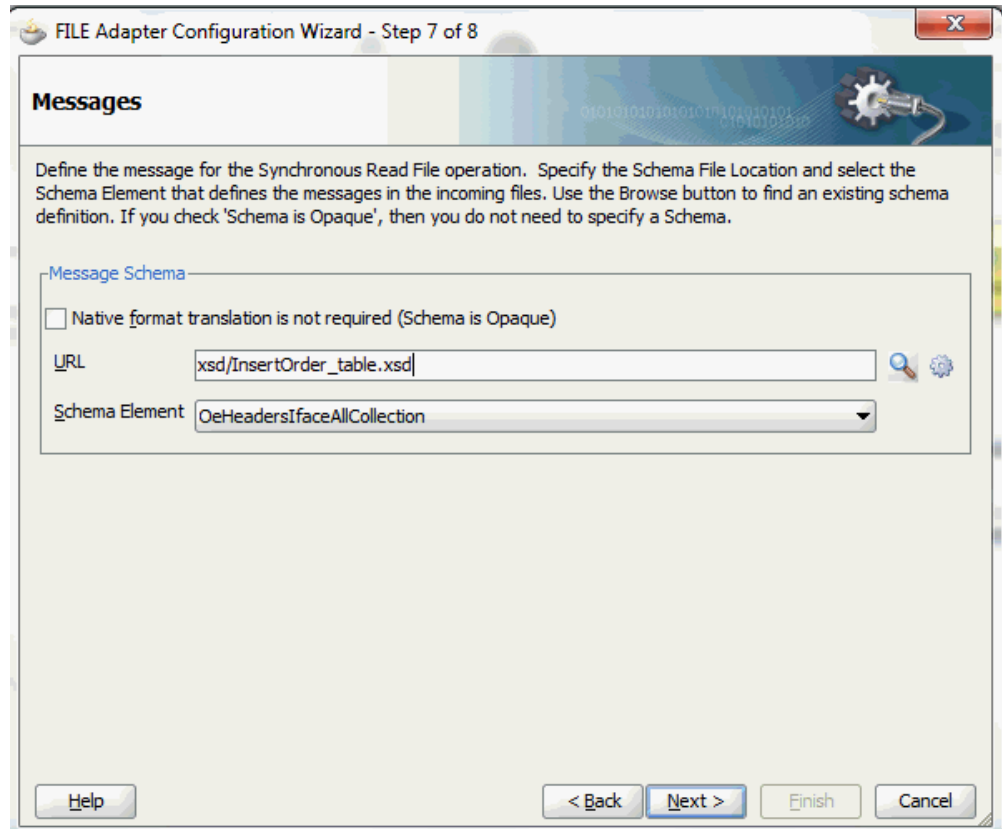

8. Click **Next** and then **Finish**. The wizard generates the WSDL file corresponding to the partner link. The main Create Partner Link dialog box appears, specifying the new WSDL file `getOrderDetails.wsdl`.

Click **Apply** and **OK** to complete the configuration and create the partner link with the required WSDL settings for the File Adapter service.

The `getOrderDetails` Partner Link appears in the BPEL process diagram.

## Configuring Invoke Activities

After configuring partner links, you need to configure the following two Invoke activities:

1. To get the acknowledgement data by invoking the `ViewAck` partner link.
2. To write acknowledgement data to an XML file by invoking `WriteAckdata` partner link for File Adapter.

**To add the first Invoke activity for a partner link to get acknowledgement data:**

1. In Oracle JDeveloper BPEL Designer, expand the **BPEL Constructs** from the Component Palette. Drag and drop the first **Invoke** activity into the center swim lane of the process diagram, between the **receiveInput** and **callbackClient** activities.

#### **Adding an Invoke Activity**

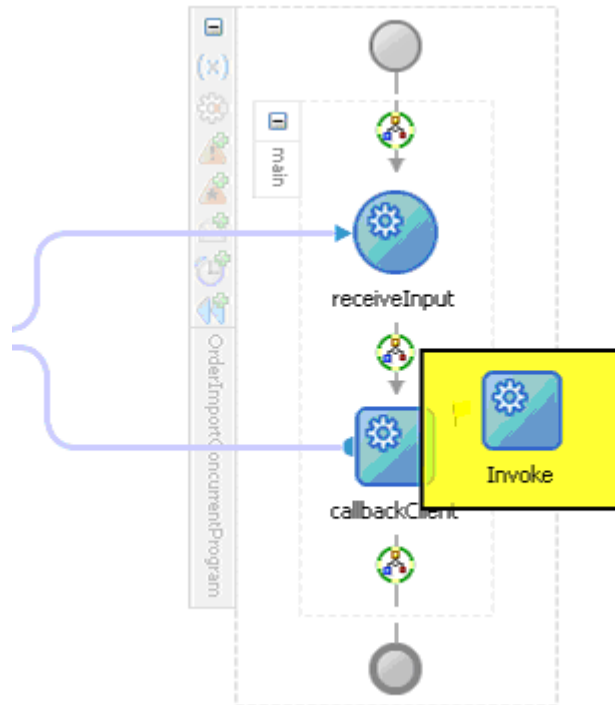

2. Link the Invoke activity to the `viewAck` service. The Edit Invoke dialog appears.
3. Enter a name for the Invoke activity, then click the **Create** icon next to the **Input Variable** field to create a new variable. The Create Variable dialog box appears.
4. Select **Global Variable**, then enter a name for the variable. You can also accept the default name. Click **OK**.
5. Click the **Create** icon next to the **Output Variable** field to create a new variable. The Create Variable dialog box appears.
6. Select **Global Variable**, then enter a name for the variable. You can also accept the default name. Click **OK**.

Click **Apply** and **OK** in the Edit Invoke dialog box to finish configuring the Invoke activity.

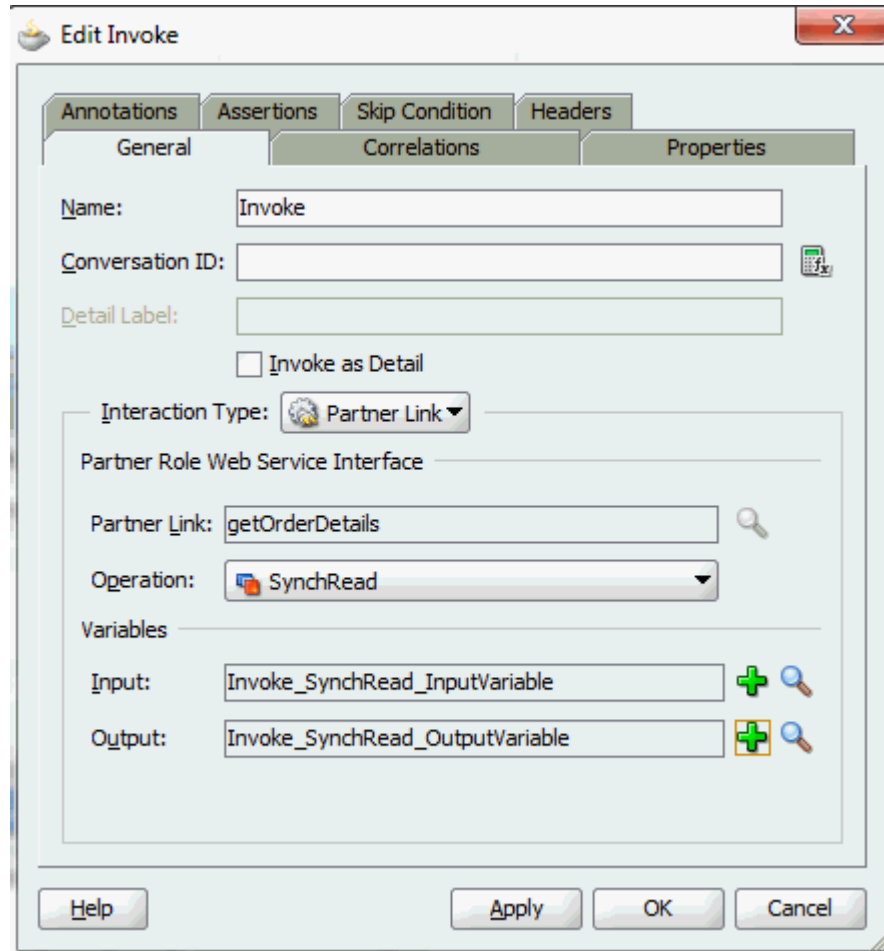

The Invoke activity appears in the process diagram.

**To add the second Invoke activity for a partner link to insert order data into Open Interface tables:**

1. In Oracle JDeveloper BPEL Designer, expand the **BPEL Constructs** from the Component Palette. Drag and drop the second **Invoke** activity into the center swim lane of the process diagram, between the first **Invoke** and **callbackClient** activities.
2. Link the Invoke activity to the `InsertOrder` service. The Edit Invoke dialog box appears.
3. Repeat Step 3 and Step 4 described in the first Invoke activity procedure. Click **Apply** and then **OK** in the Edit Invoke dialog box to finish configuring the second Invoke activity.

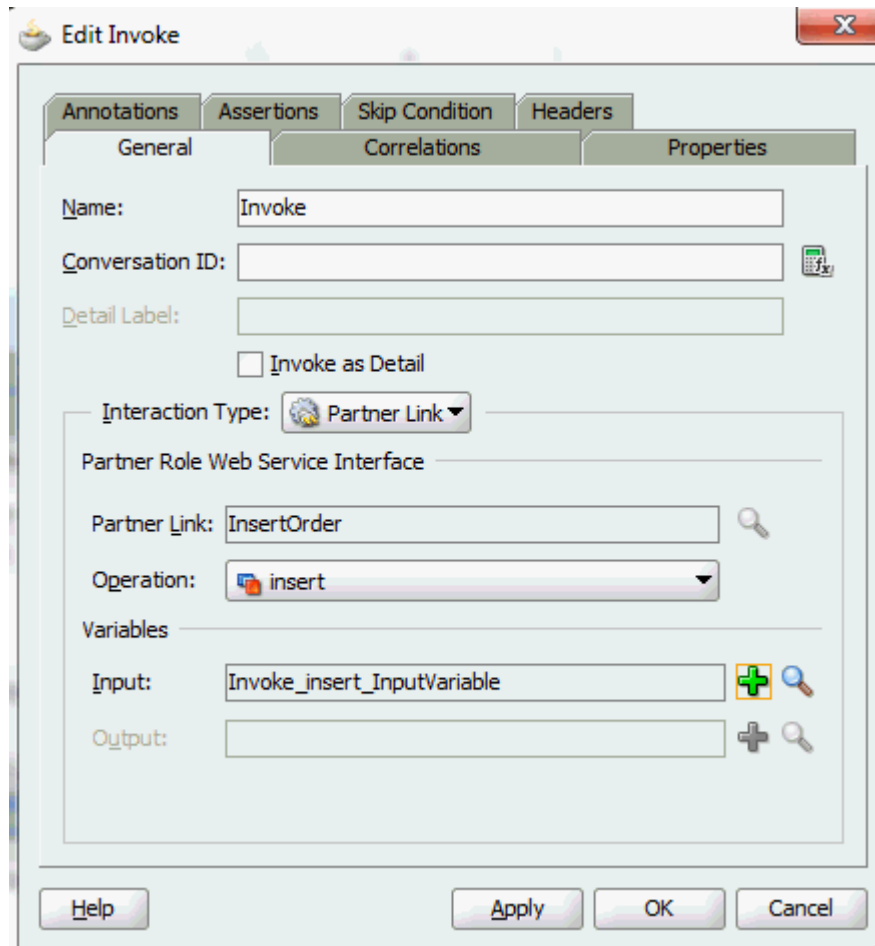

## Configuring an Assign Activity

The next task is to add an Assign activity to the process map. This is used to pass the output of File Adapter's Synchronous Read (`getOrderDetails`) service as an input to the Open Interface `InsertOrder` service.

### To add an Assign activity:

1. In JDeveloper BPEL Designer, expand the **BPEL Constructs** from the Component Palette.

Drag and drop the **Assign** activity into the center swim lane of the process diagram, between the first and second **Invoke** activities that you just created earlier.

2. Double-click the **Assign** activity to access the Edit Assign dialog.

Click the General tab to enter a name for the Assign activity. For example, `SetOrderDetails`.



3. Enter the following parameter information:
  - In the From navigation tree, navigate to **Variable > Process > Variables > Invoke\_SynchRead\_OutputVariable** and select **body**.
  - In the To navigation tree, navigate to **Variable > Process > Variables > Invoke\_insert\_InputVariable** and select **OeHeadersIfaceAllCollection**.

Drag the source node (body) to connect to the target node (OeHeadersIfaceAllCollection) that you just specified. This creates a line that connects the source and target nodes. The copy rule is displayed in the From and To sections at the bottom of the Edit Assign dialog box.

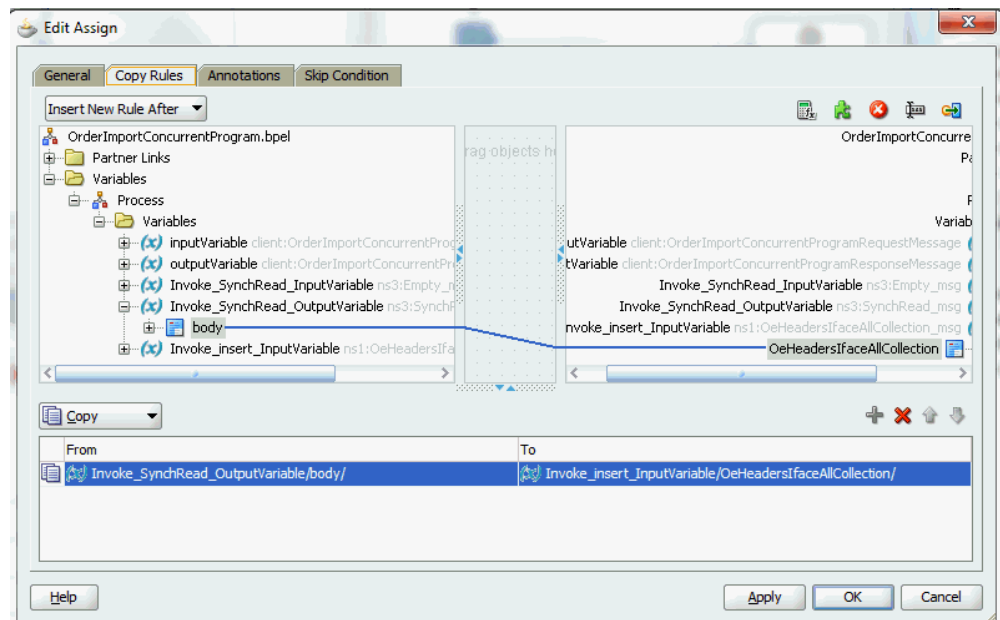

4. Click **Apply** and then **OK** to complete the configuration of the Assign activity.

### Completed BPEL Process Diagram

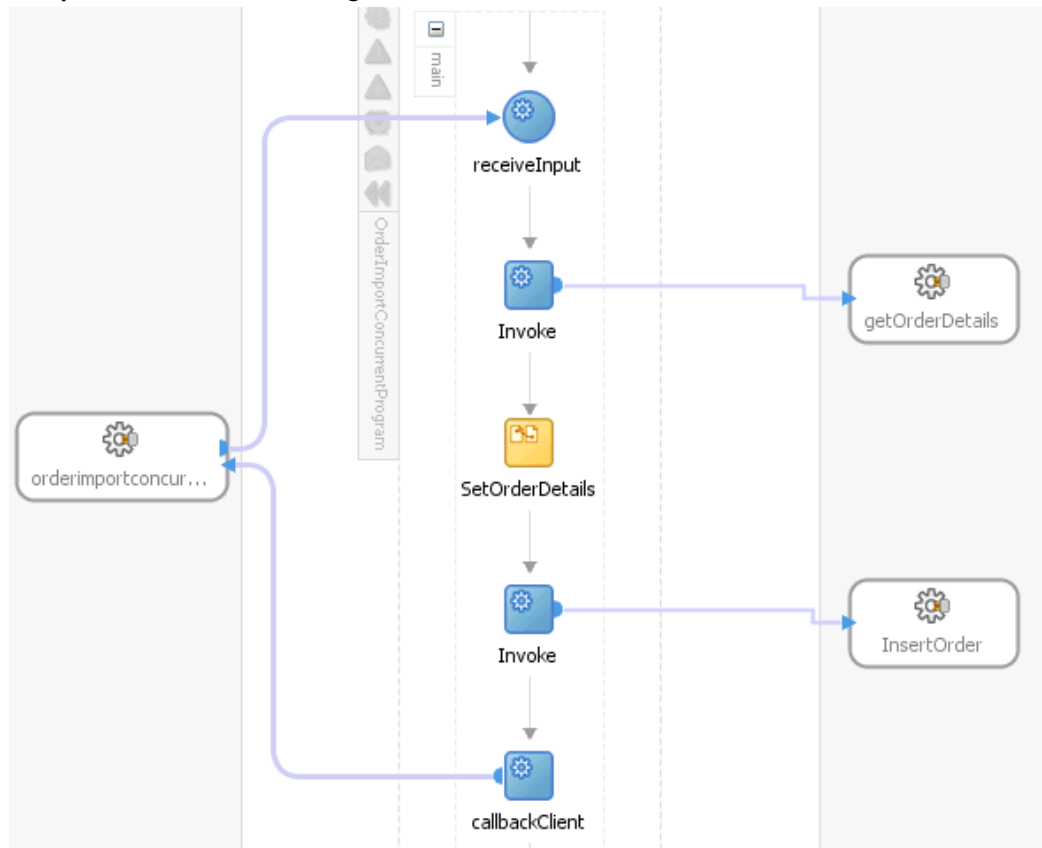

Click the `composite.xml` to display the Oracle JDeveloper composite diagram:

**Note:** Click the Source tab of `composite.xml` to enter a value for the physical directory `inputDir` for the reference `getOrderDetails` (such as `/usr/tmp`).

```
<property name="inputDir" type="xs:string"
many="false" override="may">/usr/tmp</property>
```

## Run-Time Tasks for Interface Tables

After designing the SOA Composite application with BPEL process, the next step is to deploy, run, and monitor it.

1. Deploy the SOA Composite application with BPEL process, page 8-33
2. Test the deployed SOA Composite application with BPEL process, page 8-36

## Deploying the SOA Composite Application with BPEL Process

To invoke the services from the BPEL client contained in the SOA composite, the SOA composite needs to be deployed to the Oracle WebLogic managed server. This can be achieved using Oracle JDeveloper. Once the composite is deployed, it can be tested from the Oracle Enterprise Manager Fusion Middleware Control Console.

### Prerequisites

Before deploying the SOA composite with BPEL process using Oracle JDeveloper, you must have established the connectivity between the design-time environment and the run-time server. For more information, see *Configuring the Data Source in Oracle WebLogic Server*, page A-3 and *Creating an Application Server Connection*, page A-12.

**Note:** If a local instance of the WebLogic Server is used, start the WebLogic Server by selecting **Run > Start Server Instance** from Oracle JDeveloper. Once the WebLogic Admin Server "DefaultServer" instance is successfully started, the <Server started in Running mode> and DefaultServer started message in the Running:DefaultServer and Messages logs should appear.

### To deploy the SOA Composite application with BPEL process:

1. Select the SOA Composite project in the Applications Navigator.
2. Right-click the project name, and then select **Deploy > [project name] > [serverConnection]** from the menu that appears.

For example, you can select **Deploy > InsertOrder > soa-server1** to deploy the process if you have the connection set up appropriately.

**Note:** If this is the first time to set up server connection, then the Deployment Action window appears. Select 'Deploy to Application Server' and click **Next**.

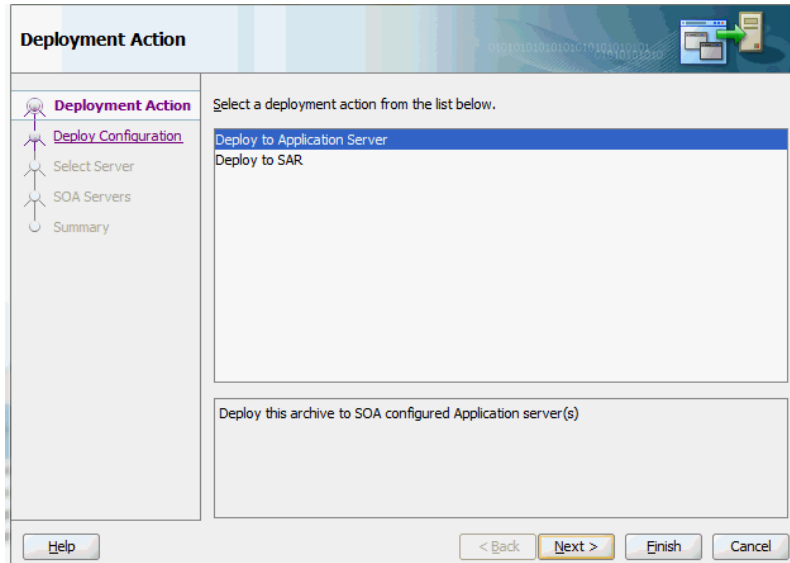

In the Deploy Configuration window, ensure the following information is selected before clicking **Next** to add a new application server:

- New Revision ID: 1.0
- Mark composite revision as default: Select this check box.
- Overwrite any existing composites with the same revision ID: Select this check box.

The steps to create a new Oracle WebLogic Server connection from JDeveloper are covered in [Creating an Application Server Connection](#), page A-12.

3. In the Select Server page, select 'soa-server1' that you have established the server connection earlier. Click **Next**.

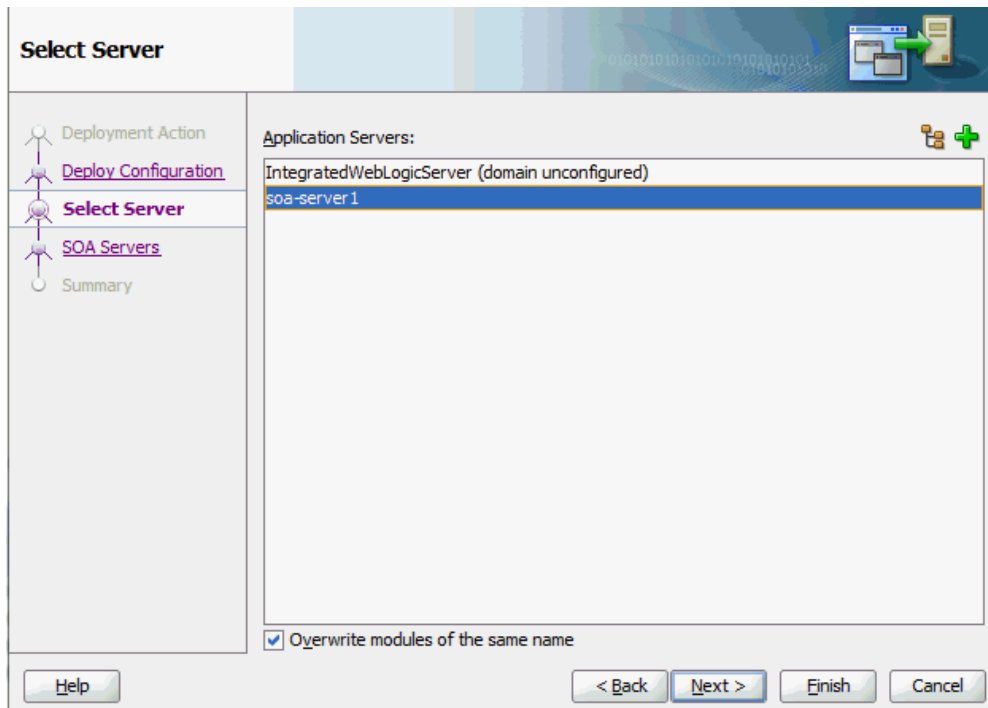

4. In the SOA Servers page, accept the default target SOA Server ('soa-server1') selection.

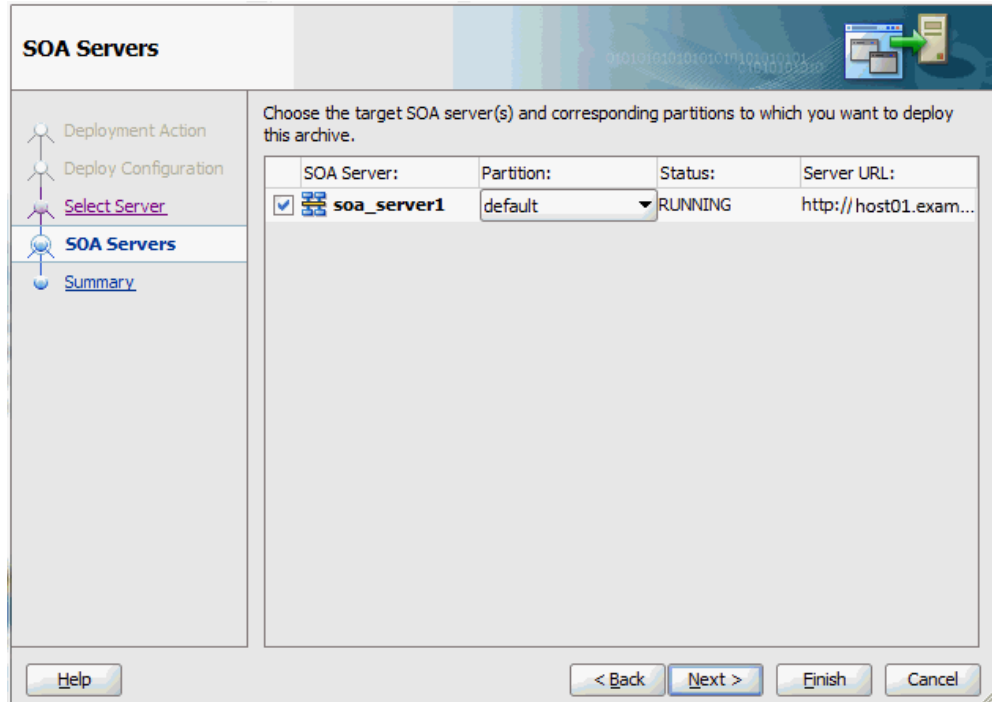

Click **Next** and **Finish**.

If you are deploying the composite for the first time from your Oracle JDeveloper session, the Authorization Request window appears. Enter username and password information specified during Oracle SOA Suite installation. Click **OK**.

5. Deployment processing starts. Monitor deployment progress and check for successful compilation in the SOA - Log window as well as in the Deployment - Log window.

## Testing the Deployed SOA Composite Application with BPEL Process

Once the SOA Composite application with BPEL process is deployed, you can manage and monitor the process from the Oracle Enterprise Manager Fusion Middleware Control Console. You can also test the process and the integration interface by manually initiating the process.

### To manually initiate and monitor the deployed SOA Composite application with BPEL process:

1. Navigate to Oracle Enterprise Manager Fusion Middleware Control Console (<http://<servername>:<portnumber>/em>). The composite you deployed is displayed in the Applications Navigation tree.

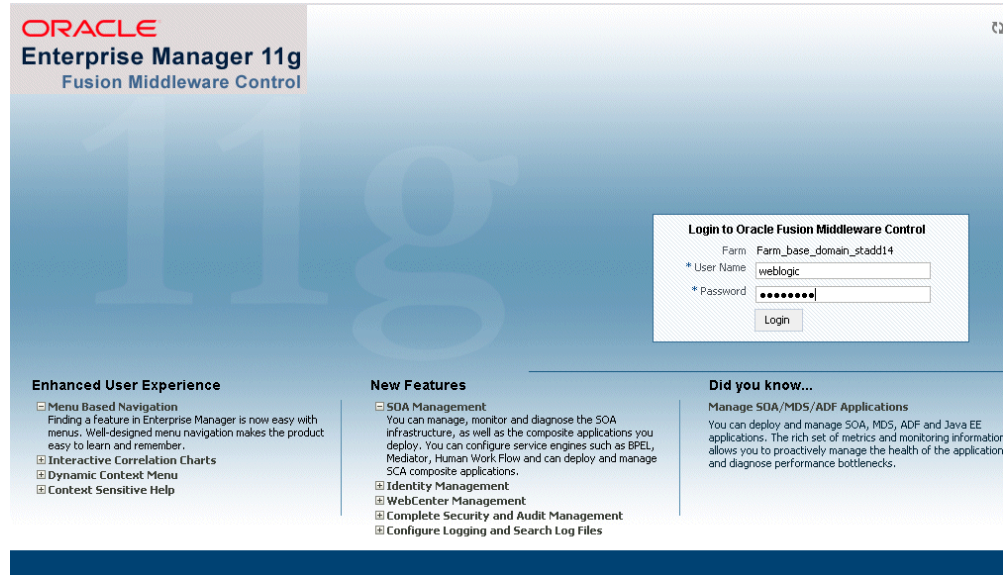

2. Enter username (such as `weblogic`) and password and click **Login** to log in to a farm.

You may need to select an appropriate target instance farm if there are multiple target Oracle Enterprise Manager Fusion Middleware Control Console farms.

3. From the Farm base domain, expand the **SOA >soa-infra** to navigate through the SOA Infrastructure home page and menu to access your deployed SOA composite applications running in the SOA Infrastructure for that managed server.

**Note:** The Farm menu always displays at the top of the navigator. As you expand the SOA folder in the navigator and click the links displayed beneath it, the SOA Infrastructure menu becomes available at the top of the page.

Click the SOA Composite application that you want to initiate (such as 'OrderInsert') from the SOA Infrastructure.

Click **Test** at the top of the page.

4. The Test Web Service page for initiating an instance appears. You can specify the XML payload data to use in the Input Arguments section.

Enter the input string required by the process and click **Test Web Service** to initiate the process.

### Testing Web Service

Name	Type	Value
* payload	payload	
* input	string	test

The test results appear in the Response tab upon completion.

5. Click on the SOA Composite application name and then click the Instances tab. The SOA Composite application instance ID, name, conversation ID, most recent known state of each instance since the last data refresh of the page are displayed.

In the Instance ID column, click a specific instance ID to show the message flow through the various service components and binding components. The Flow Trace page is displayed.

In the Trace section, you should find the sequence of the message flow for the service binding component (`insertorder_client_ep`), BPEL component (`InsertOrder`), and reference binding components (`getOrderDetails` and `InsertOrder`). All involved components have successfully received and processed messages.

If any error occurred during the test, you should find it in the Faults section.



## Flow Trace Page

Data Refreshed Mar 5, 2009 12:46:45 AM

Flow Trace ⓘ  
This page shows the flow of the message through various composite and component instances. ⓘ

ECCID 0000HzLnKdt5uXApJ~1Fif19f\_9n00001Qz46  
Started Mar 5, 2009 12:43:34 AM

**Faults**  
Select a fault to locate it in the trace view.

Error Message	Recovery	Fault Time	Fault Location	Composite Instance
No faults found				

**Trace**  
Click a component instance to see its detailed audit trail.  
Show Instance IDs

Instance	Type	State	Time	Composite Instance
InsertOrder_client_ep	Service	Completed	Mar 5, 2009 12:43:34 AM	adapters-apps InsertOr
InsertOrder	BPEL Component	Completed	Mar 5, 2009 12:43:36 AM	adapters-apps InsertOr
getOrderDetails	Reference	Completed	Mar 5, 2009 12:43:34 AM	adapters-apps InsertOr
InsertOrder	Reference	Completed	Mar 5, 2009 12:43:34 AM	adapters-apps InsertOr

6. Click your BPEL service component instance link (such as `InsertOrder`) to display the Instances page where you can view execution details for the BPEL activities in the Audit Trail tab.

Click the Flow tab to check the BPEL process flow diagram. Click an activity of the process diagram to view the activity details and flow of the payload through the process.

7. **Validating Records Using SQL**

To confirm that the records have been inserted into the selected Open Interface tables, you can write SQL `SELECT` statements and fetch the results showing the latest records inserted into the open interface tables.

## Design-Time Tasks for Views

This section describes the steps to configure Adapter for Oracle Applications using the Adapter Configuration Wizard in Oracle JDeveloper.

### SOA Composite Application with BPEL Process Scenario

In this example, Adapter for Oracle Applications retrieves purchase order acknowledgement information from Interface Views `OE_HEADER_ACKS_V` and `OE_LINE_ACKS_V`. The acknowledgement information will then be written to an XML file as an output for confirmation.

When the SOA Composite application with BPEL process has been successfully executed after deployment, you can validate the output XML file with the same order book reference ID once an order is approved.

### Prerequisites to Configure Views

You need to define a uniqueness criteria, which could be a single key or composite keys.

### SOA Composite Application with BPEL Process Flow

Based on the scenario, the following design-time tasks are discussed in this chapter.

1. Create a new SOA Composite application with BPEL process, page 8-40
2. Add a partner link, page 8-45
3. Add a partner link for File Adapter, page 8-59
4. Configure the Invoke activity, page 8-65
5. Configure the Assign activity, page 8-69

## Creating a New SOA Composite Application with BPEL Process

**To create a new SOA Composite application with BPEL process:**

1. Open JDeveloper BPEL Designer. Click **New Application** in the Application Navigator.

The Create SOA Application - Name your application page is displayed.

### The Create SOA Application - Name your application Page

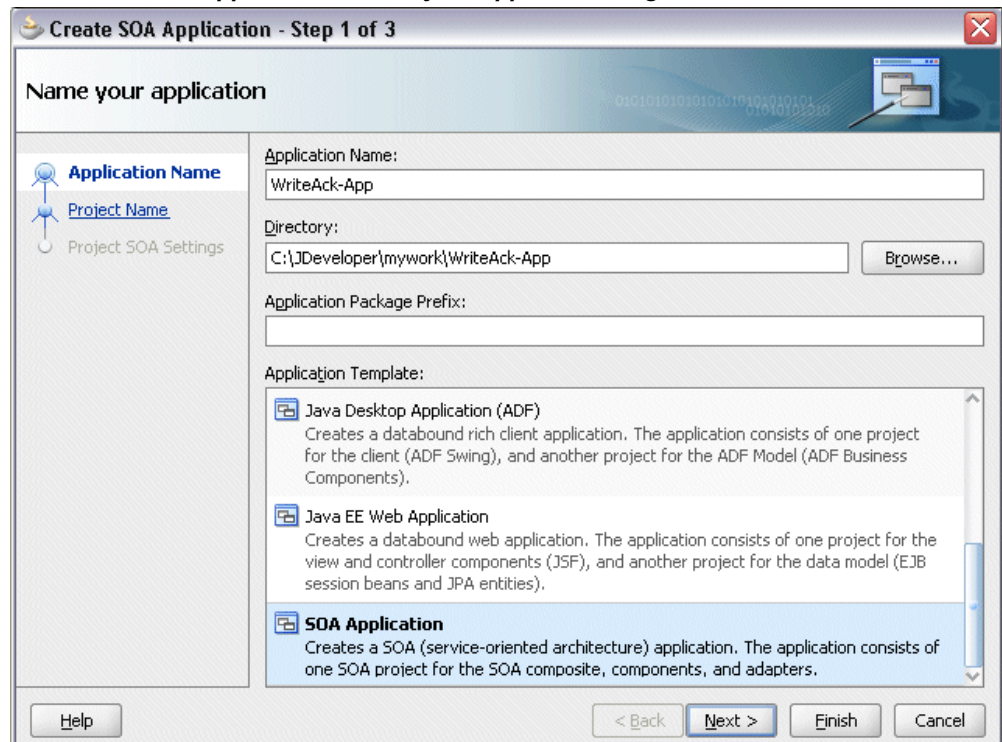

2. Enter an appropriate name for the application in the **Application Name** field and select **SOA Application** from the Application Template list.  
Click **Next**. The Create SOA Application - Name your project page is displayed.
3. Enter an appropriate name for the project in the **Project Name** field. For example, WriteAck.

### The Create SOA Application - Name your project Page

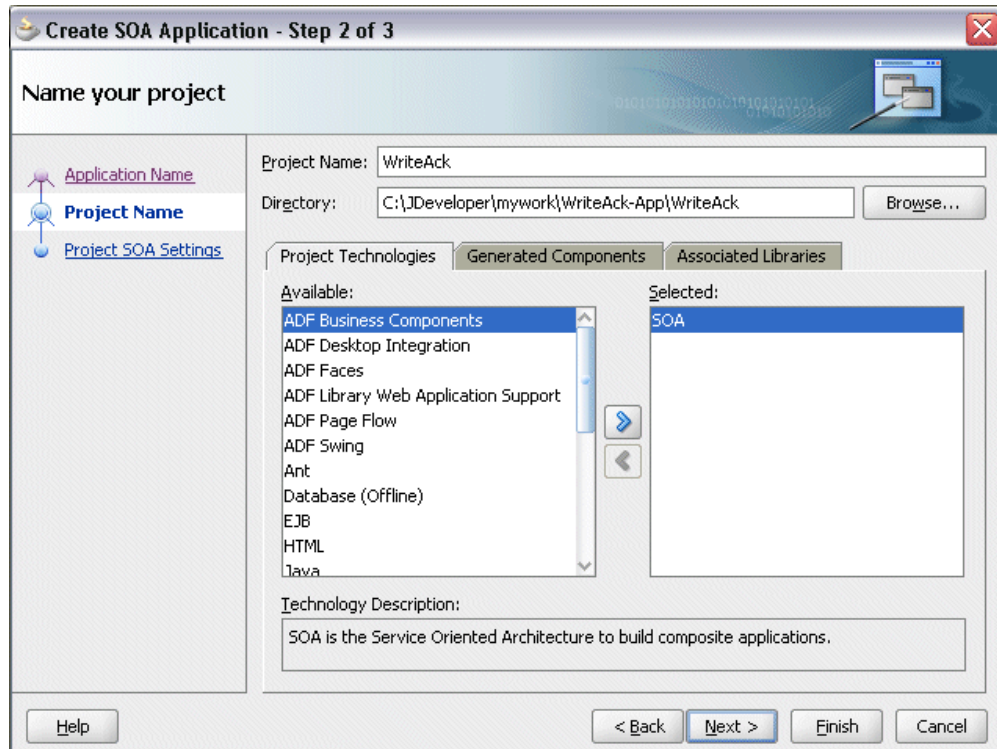

4. In the Project Technologies tab, ensure that **SOA** is selected from the Available technology list to the Selected technology list.

Click **Next**. The Create SOA Application - Configure SOA settings page is displayed.

### The Create SOA Application - Configure SOA settings Page

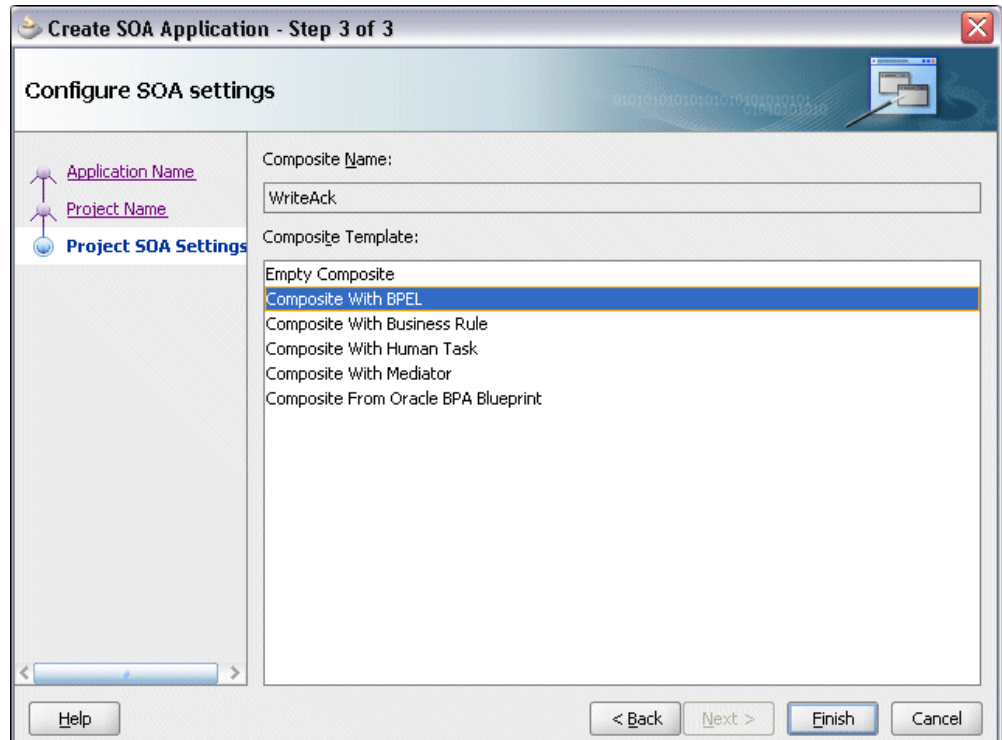

5. In the **BPEL Process Name** field, enter a descriptive name. For example, `WriteAck`.
6. Select **Composite With BPEL** from the Composite Template list, and then click **Finish**. You have created a new application and a SOA project. This automatically creates a SOA Composite application.

The Create BPEL Process page is displayed.

### The Create BPEL Process Page

**BPEL Process**

A BPEL process is a service orchestration, based on the BPEL specification, used to describe/execute a business process (or large grained service), which is implemented as a stateful service.

BPEL 1.1 Specification  BPEL 2.0 Specification

Name: WriteAck

Namespace: http://xmlns.oracle.com/WriteAck-app/WriteAck/WriteAck

Template: Asynchronous BPEL Process

Service Name: writeack\_client

Expose as a SOAP service

Delivery: async.persist

Input: {http://xmlns.oracle.com/WriteAck-app/WriteAck/WriteAck}process

Output: {http://xmlns.oracle.com/WriteAck-app/WriteAck/WriteAck}processResponse

Help OK Cancel

7. Leave the default **BPEL 1.1 Specification** selection unchanged. This creates a BPEL project that supports the BPEL 1.1 specification.

Enter an appropriate name for the BPEL process in the **Name** field. For example, WriteAck.

Select **Asynchronous BPEL Process** in the **Template** field. Click **OK**.

An asynchronous BPEL process is created with the Receive and Reply activities. The required source files including bpel and wsdl, using the name you specified (for example, WriteAck.bpel and WriteAck.wsdl) and composite.xml are also generated.

8. Navigate to SOA Content > Business Rules and click the composite.xml to view the composite diagram.

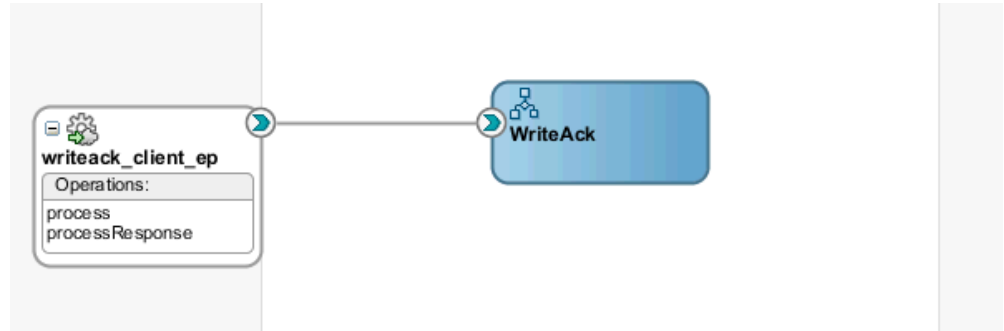

Double click on the `WriteAck` component to open the BPEL process.

## Adding a Partner Link

A BPEL partner link defines the link name, type, and the role of the BPEL process that interacts with the partner service.

In the scenario described earlier, you need to add a partner link to retrieve order acknowledgement information from selected Open Interface Views.

### To add a partner link:

1. Click **BPEL Services** in the Component palette.

Drag and drop **Oracle Applications** from the **BPEL Services** list into the right Partner Link swim lane of the process diagram. The Adapter Configuration Wizard Welcome page appears. Click **Next**.

2. Enter a service name in the **Service Name** field. For example, `ViewAck`. Click **Next**. The Service Connection dialog appears.

### Specifying a Database Service Connection

The screenshot shows a window titled "Adapter Configuration Wizard - Step 3 of 4" with a close button in the top right corner. The main heading is "Service Connection". Below the heading, there is a blue banner with a gear icon and binary code. The text reads: "A Database Connection is required to configure this adapter. Select a database connection already defined in your project or create a New Connection." Below this, there is a "Connection:" dropdown menu with "OracleAppsConnection" selected. To the right of the dropdown are three icons: a green plus sign, a pencil, and a key. Below the dropdown, the following fields are displayed: "User Name: apps", "Driver: oracle.jdbc.OracleDriver", and "Connect String: jdbc:oracle:thin:@localhost:1521:sid01". Below these fields, there is a note: "Specify the JNDI name for the database. Note: The deployment descriptor of the Oracle Applications adapter must associate this JNDI name with configuration properties required by the adapter to access the database." Below the note is a "JNDI Name:" field with the text "eis/Apps/OracleAppsConnection" entered. At the bottom of the window, there are four buttons: "Help", "< Back", "Next >", "Finish", and "Cancel".

3. You can perform either one of the following options for your database connection:

**Note:** You need to connect to the database where Oracle Applications is running.

- You can create a new database connection by clicking the **Create a New Database Connection** icon.

How to define a new database connection, see *Create a New Database Connection*, page 5-13.

- You can select an existing database connection that you have configured earlier from the **Connection** drop-down list.

The Service Connection page will be displayed with the selected connection information. The JNDI (Java Naming and Directory Interface) name corresponding to the database connection appears automatically in the **Database Server JNDI Name** field. Alternatively, you can specify a JNDI name.



**Note:** When you specify a JNDI name, the deployment descriptor of the Oracle Applications adapter must associate this JNDI name with configuration properties required by the adapter to access the database.

The JNDI name acts as a placeholder for the connection used when your service is deployed to the BPEL server. This enables you to use different databases for development and later for production.

**Note:** For more information about JNDI concepts, refer to *Oracle Fusion Middleware User's Guide for Technology Adapters*.

4. Click **Next** in the Service Connection dialog box. You can add an interface view by browsing through the list of open interface views available in Oracle Applications.

**For Oracle E-Business Suite Release 12:**

If you are connecting to Oracle E-Business Suite Release 12, then the **IREP File not present** dialog box appears indicating that Adapter could not find the Oracle Integration Repository data file corresponding to the database you are connecting in your workspace. Absence of the data file would make browsing or searching of Integration Repository tree considerably slow. You can choose to extract the data file and create a local copy of the Integration Repository data file. Once it is created successfully, Adapter will pick it up automatically next time and retrieve data from your local Integration Repository.

You can select one of the following options:

- Click **Yes** to extract the Integration Repository data file.

### Extracting Integration Repository Data File

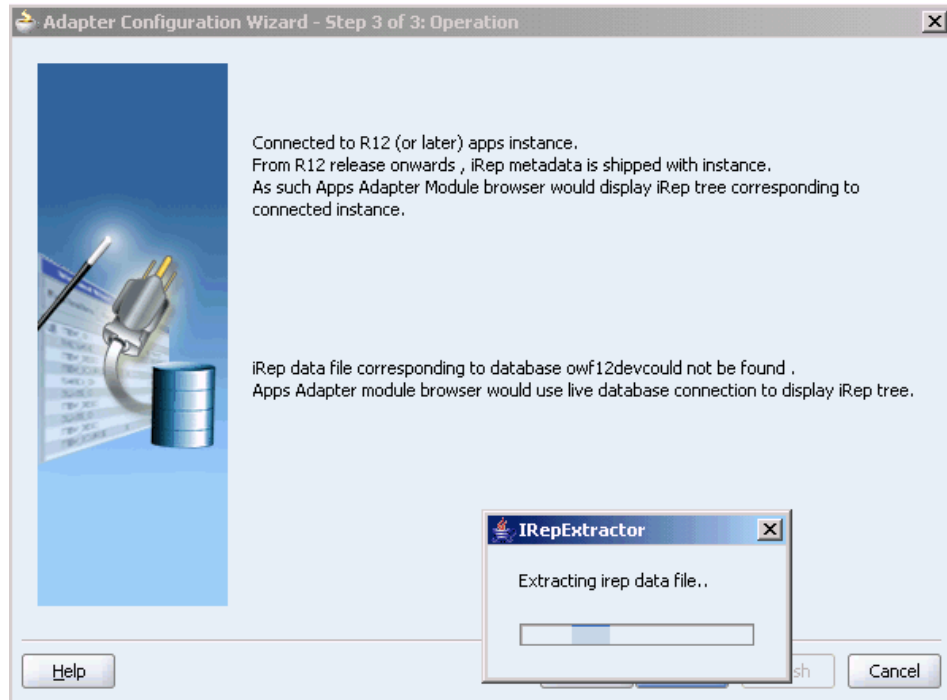

After the system successfully creates a local copy of the Integration Repository data file, next time when you connect to the database, you will find the **IRep Data File** field appears in the Operation dialog box indicating where your local copy exists with the creation date and time as part of the file name.

### Using the Local Integration Repository Data File

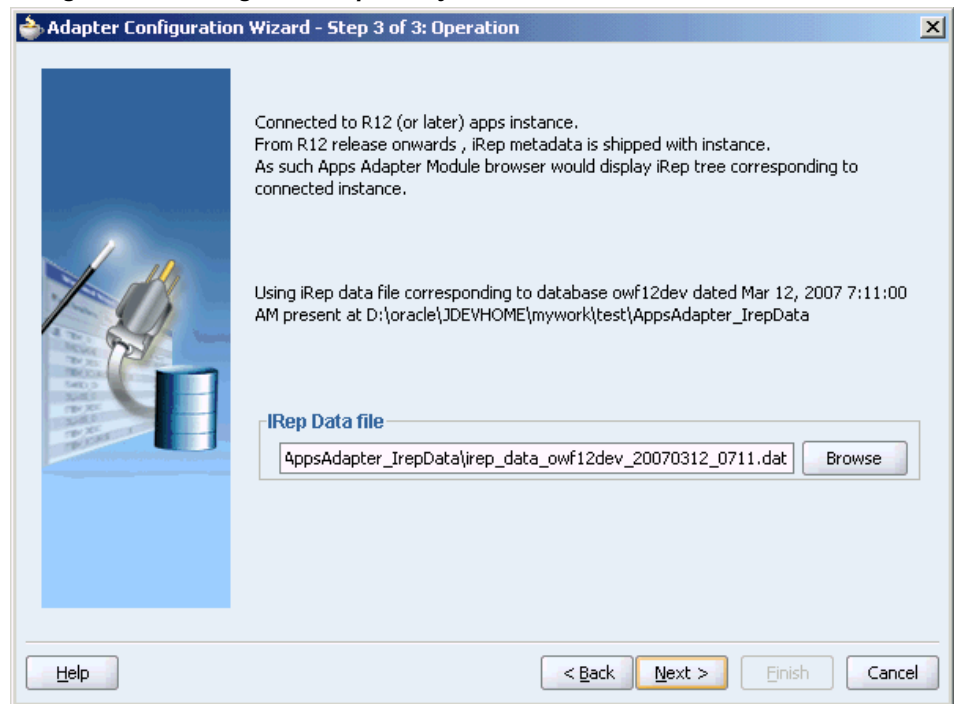

- Click **No** to query the Integration Repository data file from the live database you are connecting to display the Integration Repository tree.

#### For Oracle E-Business Suite Release 11.5.9:

If you are connecting to an Oracle E-Business Suite Release 11.5.9 instance, you must select the interface type in the Adapter Configuration Wizard. Select **Tables/Views/APIs/Concurrent Programs** to proceed.

5. Click **Get Object** to open the Oracle Applications Module Browser.

## Selecting a view from the Module Browser

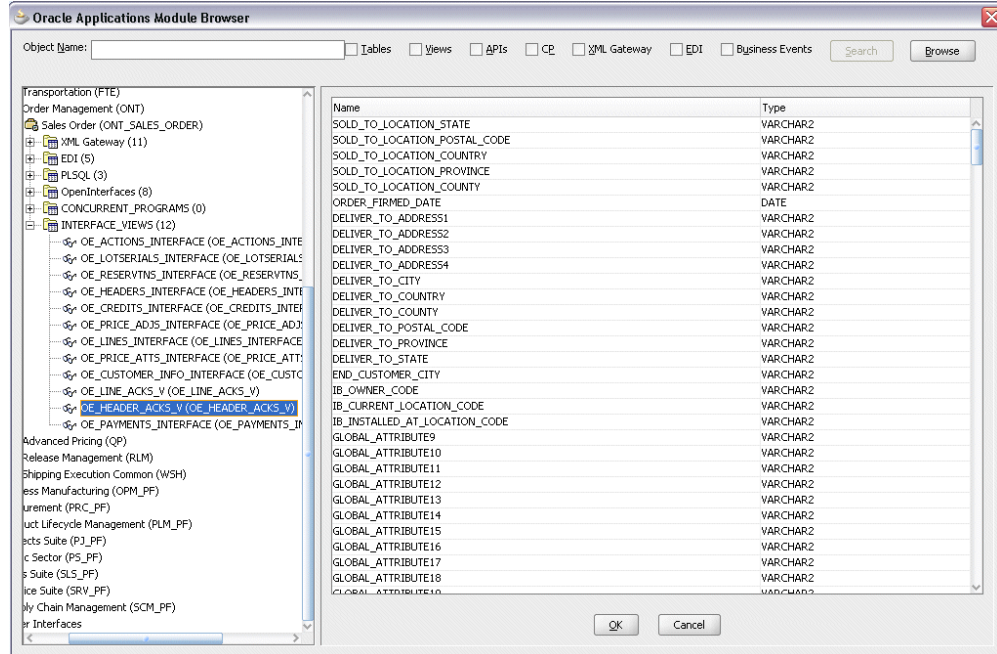

Oracle Applications Module Browser includes the various product families that are available in Oracle Applications. For example, Applications Technology or Order Management Suite are product families in Oracle Applications. The product families contain the individual products. For example, Order Management Suite contains the Order Management product. The individual products contain the business entities associated with the product. For example, the Order Management product contains the Sales Order business entity.

Business entities contain the various application modules that are exposed for integration. These modules are grouped according to the interface they provide. concurrent programs can be found under the Open Interfaces category.

6. Navigate to *Order Management Suite (OM\_PF) > Order Management (ONT) > Sales Order (ONT\_SALES\_ORDER) > Interface\_Views* to select *OE\_HEADER\_ACKS\_V*. Click **OK**. The Application Interface page appears with the selected interface view.

### Adapter Configuration Wizard - Application Interface Page

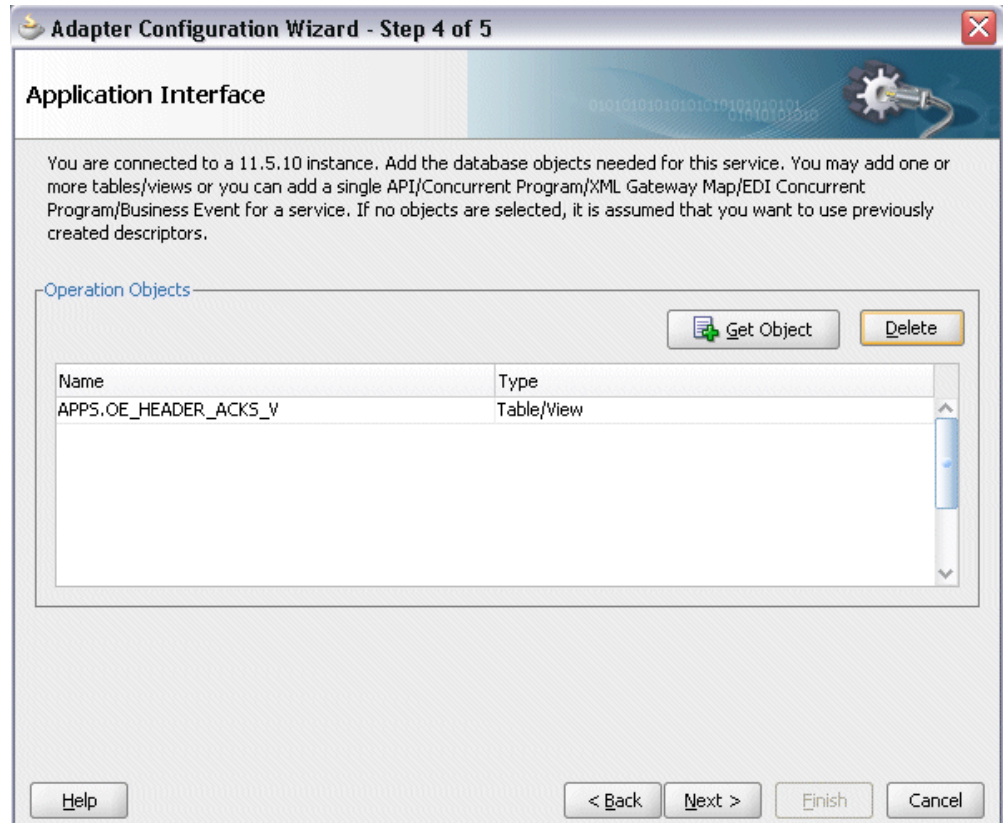

7. Click **Get Object** to open the Oracle Applications Module Browser again to select another interface view `OE_LINE_ACKS_V` using the same navigation path *Order Management Suite (OM\_PF) > Order Management (ONT) > Sales Order (ONT\_SALES\_ORDER) > Interface\_Views*.

Click **OK**. The Application Interface page appears with the two selected views.

### Adapter Configuration Wizard - Application Interface Page

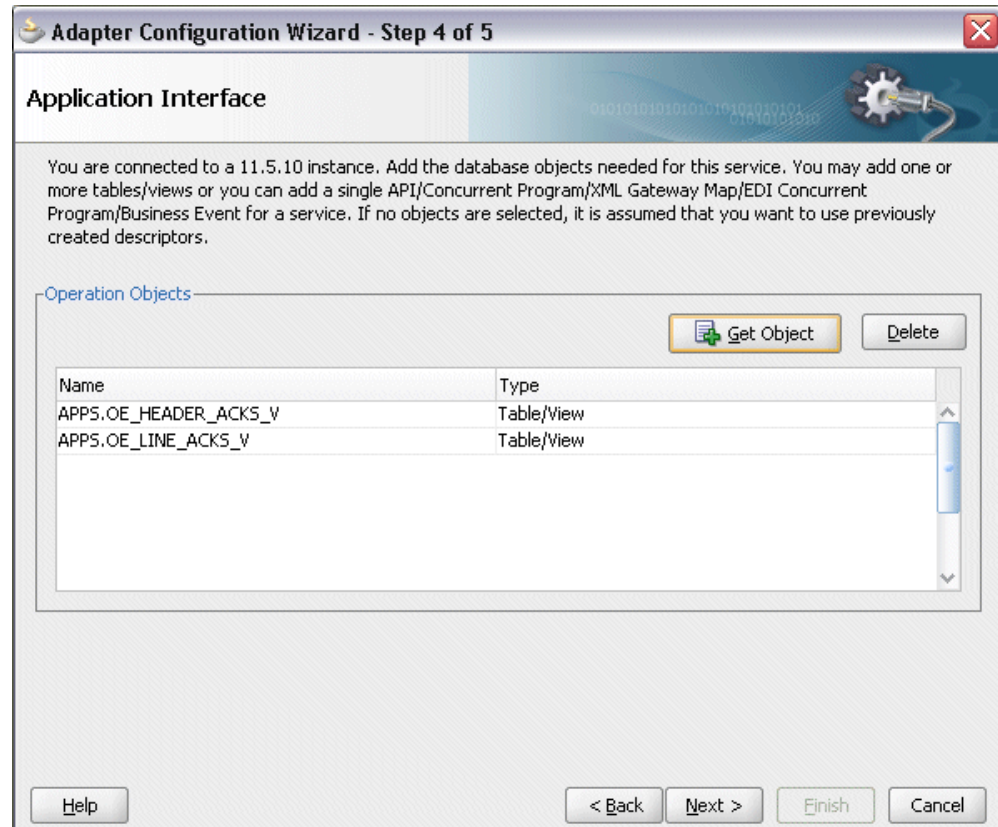

Click **OK**.

8. Click **Next**. The Operation Type page is displayed.

### Adapter Configuration Wizard - Operation Type Page

Adapter Configuration Wizard - Step 5 of 11

#### Operation Type

Select the Operation Type and click Next to continue defining the operation.

Operation Type:  Perform an Operation on a Table  
 Insert  
 Select  
 Poll for New or Changed Records in a Table

Do Synchronous Post to BPEL (Allows In-Order Delivery)

Help < Back Next > Finish Cancel

Select the **Perform an Operation on a Table** radio button and then choose the **Select** check box.

**Note:** Interface views can be used only for Select operations.

9. Click **Next**. The Select Table page is displayed.

### Adapter Configuration Wizard - Select Table Page

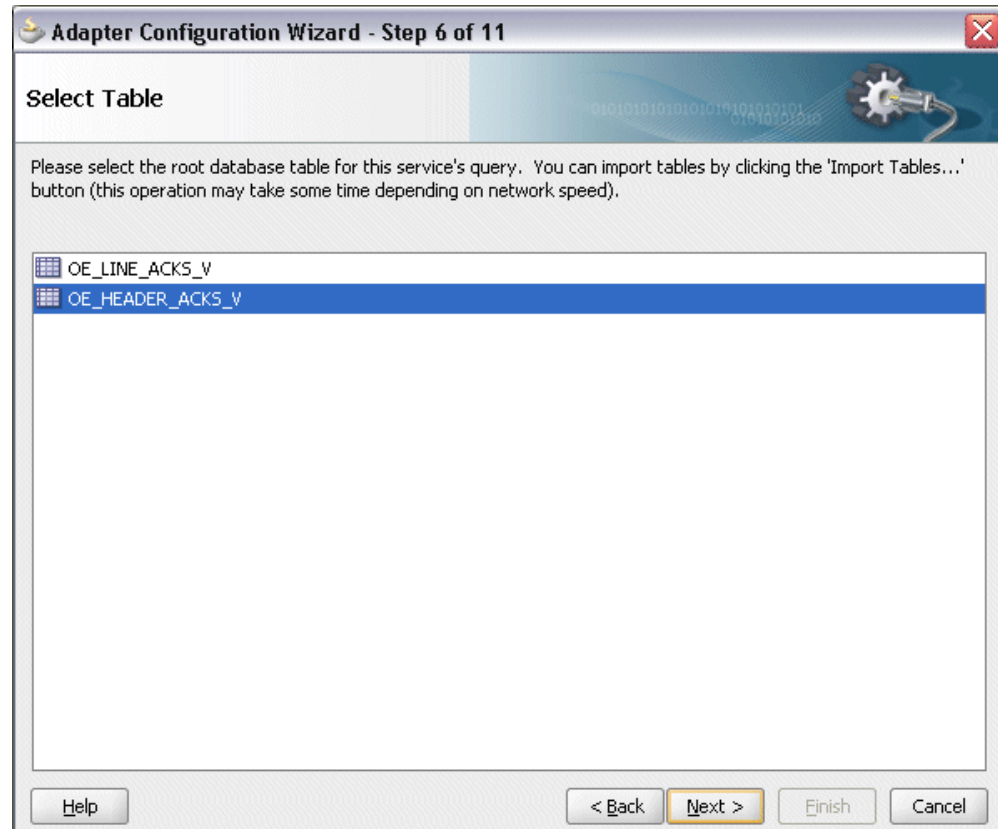

Select OE\_HEADERS\_ACKS\_V as the root database table for this service's query.

10. Click Next. The Define Primary Keys page is displayed.



## Adapter Configuration Wizard - Define Primary Keys Page for OE\_HEADERS\_ACKS\_V

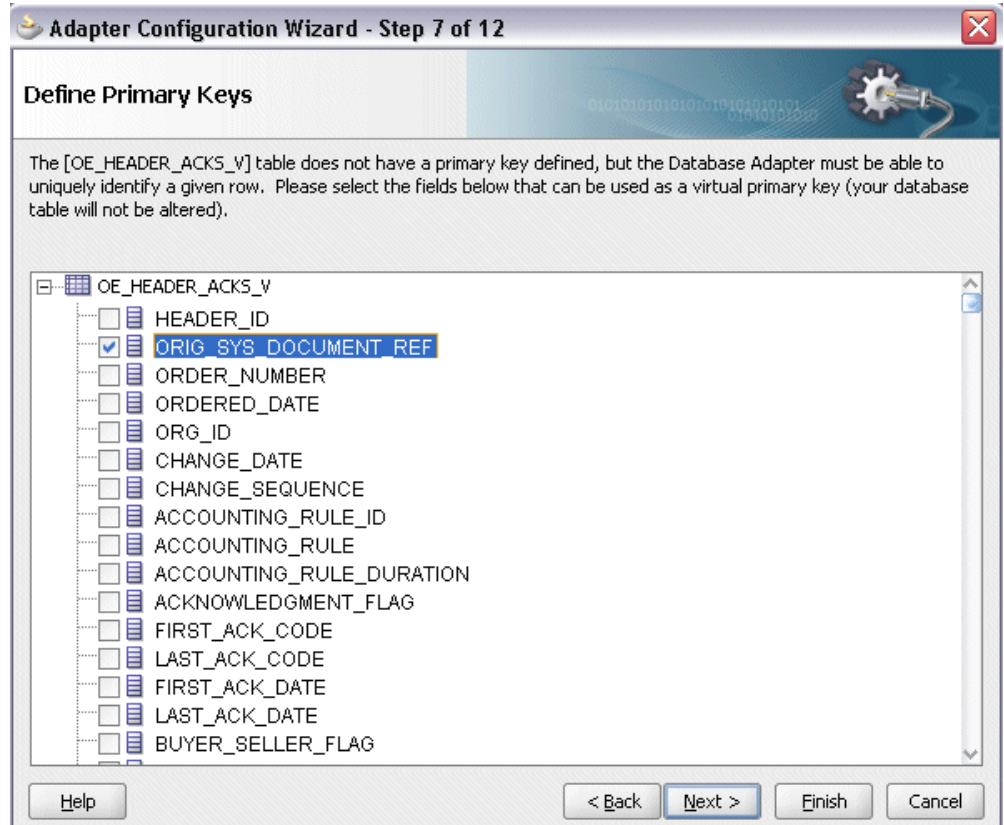

Select the following primary keys for the OE\_HEADERS\_ACKS\_V table:

- ORIG\_SYS\_DOCUMENT\_REF
- ORDER\_SOURCE\_ID

Click **Next**.

Select the same primary keys for the OE\_LINE\_ACKS\_V table.

### Adapter Configuration Wizard - Define Primary Keys Page for OE\_LINE\_ACKS\_V

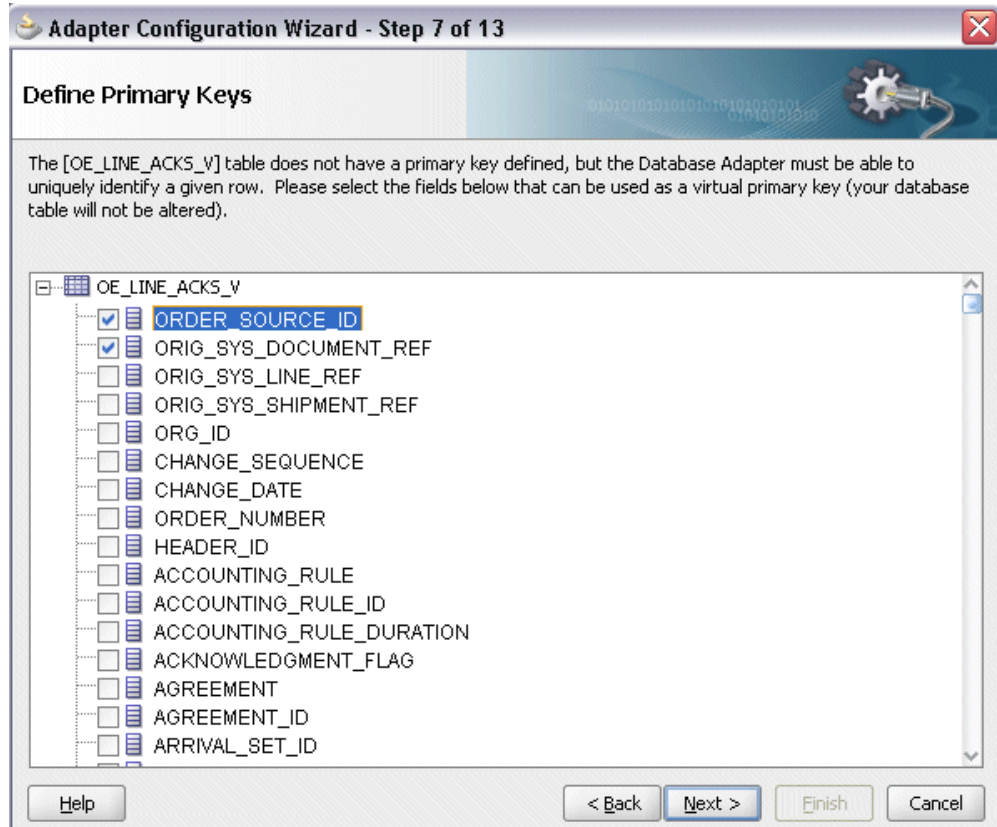

11. Click **Next**. The Relationships page appears.  
Click **Create** to open the Create Relationship dialog.

## Defining Relationships

Please specify the parent and child tables, relation type and relation name. You also must specify the foreign key / primary key associations in the table below.

Parent Table:

Child Table:

OE\_HEADER\_ACKS\_V has a 1:1 Relationship with OE\_LINE\_ACKS\_V

OE\_HEADER\_ACKS\_V has a 1:1 Relationship with OE\_LINE\_ACKS\_V (Foreign Key on Child table)

OE\_HEADER\_ACKS\_V has a 1:M Relationship with OE\_LINE\_ACKS\_V

Private Owned

OE_HEADER_ACKS_V	OE_LINE_ACKS_V
OE_HEADER_ACKS_V.Orig_Sys_Document_Ref	Orig_Sys_Document_Ref
OE_HEADER_ACKS_V.Order_Source_Id	Order_Source_Id

Relationship Name:

Enter the following information to define the relationship between the header and the detail table:

- Select the OE\_HEADERS\_ACKS\_V as the parent table and OE\_LINES\_ACKS\_V as the child table.
- Select the mapping type: OE\_HEADERS\_ACKS\_V has a 1:M Relationship with OE\_LINES\_ACKS\_V

**Note:** If foreign key constraints between tables already exist in the database, then two relationships are created automatically while importing tables. One of the relationships is 1:M relationship from the source table, which is the table containing the foreign key constraints, to the target table. The other relationship is a 1:1 back pointer from the target table to the source table.

- Select the **Private Owned** check box.
- Associate the foreign key fields with the primary key fields:
  - OE\_HEADERS\_ACKS\_V.ORDER\_SOURCE\_ID: ORDER\_SOURCE\_ID
  - OE\_HEADERS\_ACKS\_V.ORIG\_SYS\_DOCUMENT\_REF:  
ORIG\_SYS\_DOCUMENT\_REF
- The Relationship Name field is populated automatically by default. You can optionally specify a new name for the relationship you are creating.

Click **OK**. The newly created relationship information appears in the Relationships page.

12. Click **Next**. The Attribute Filtering page appears. Leave default selections unchanged.

## Adapter Configuration Wizard - Attribute Filtering Page

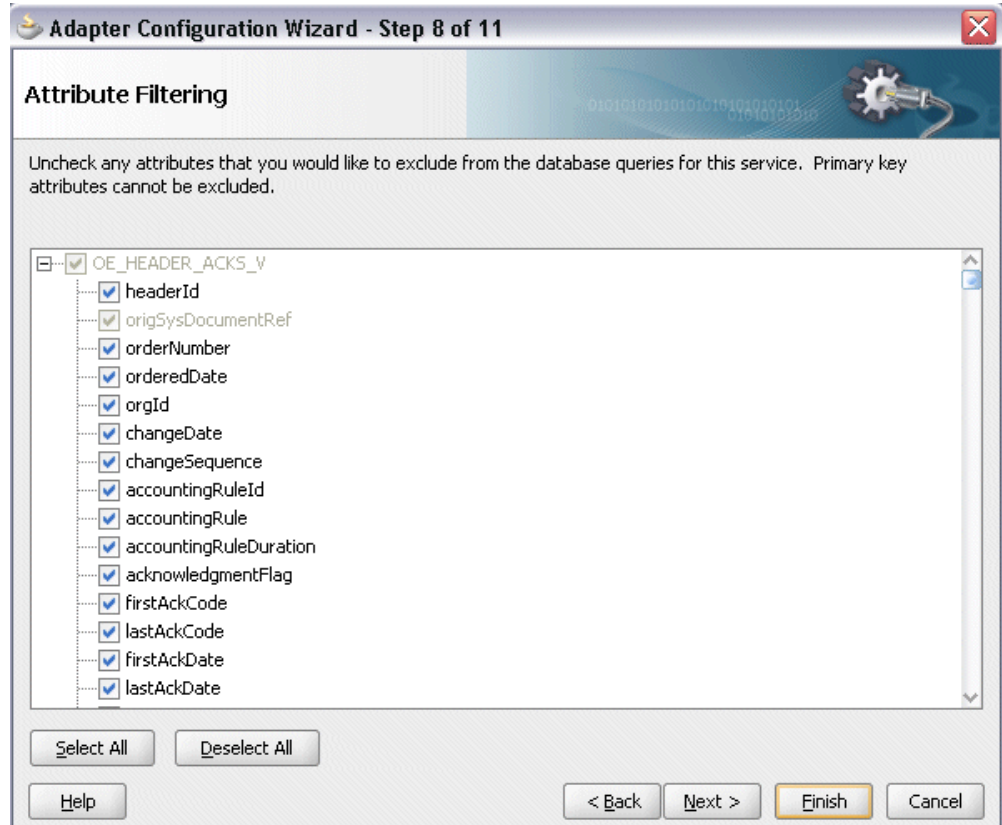

Click **Next**. The Define Selection Criteria page appears.

Click **Add** to add a new parameter if necessary. Click **Edit** to use the graphical expression builder to create the expression. You can define your own custom Select SQL by modifying the predefined SQL string.

13. Click **Next**. The Advanced Options page appears.

Click **Next**.

14. Click **Finish**. The wizard generates the WSDL file corresponding to the selected interface. This WSDL file is now available for the partner link.

Click **Apply** and then **OK**. The partner link is created with the required WSDL settings.

## Adding a Partner Link for File Adapter

Use this step to configure a BPEL process by adding a partner link for File Adapter. This allows the acknowledgement data to be written to an XML file.

### To add a partner link for the file adapter:

1. In Oracle JDeveloper BPEL Designer, click **BPEL Services** in the Component palette.

Drag and drop **File Adapter** from the **BPEL Services** list into the right Partner Link swim lane of the process diagram right after the partner link you just created. The Adapter Configuration Wizard Welcome page appears.

Click **Next**.

2. In the Service Name page, enter a name for the file adapter service, such as WriteAckdata.

#### Specifying the Service Name

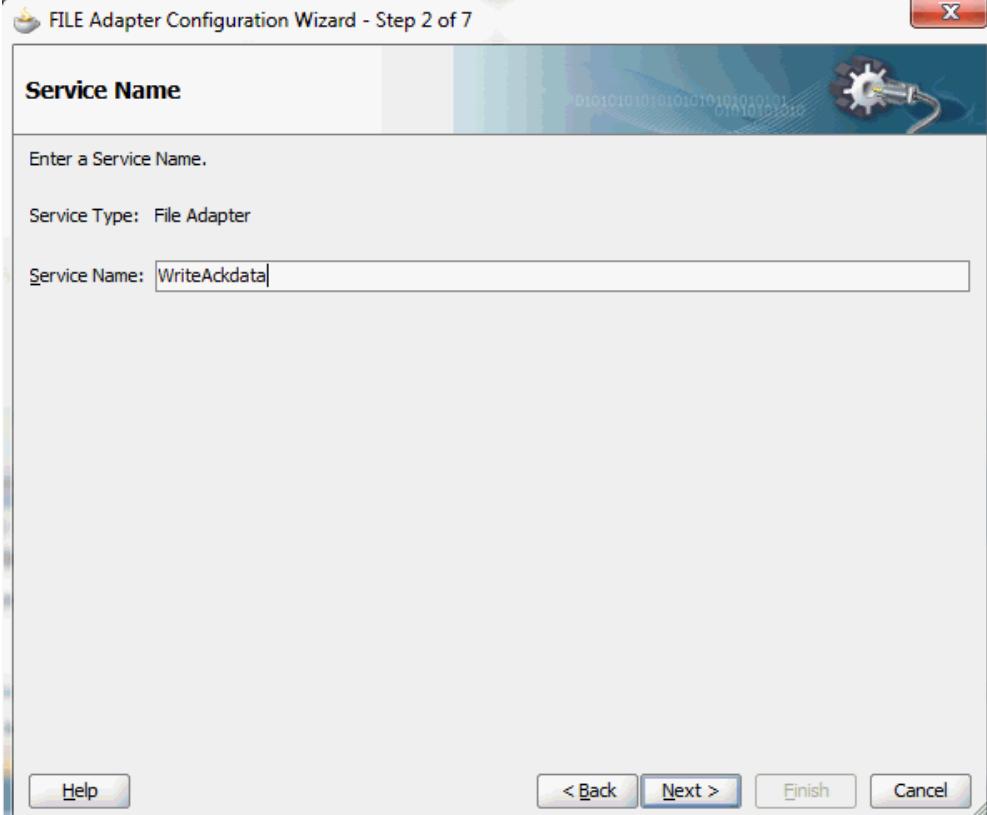

The screenshot shows a dialog box titled "FILE Adapter Configuration Wizard - Step 2 of 7". The main heading is "Service Name". Below the heading, it says "Enter a Service Name." and "Service Type: File Adapter". A text input field labeled "Service Name:" contains the text "WriteAckdata". At the bottom of the dialog, there are four buttons: "Help", "< Back", "Next >", and "Cancel". The "Next >" button is highlighted with a blue border.

3. Enter a name for the file adapter service, such as WriteAckData.
4. Click **Next**. The Adapter Interface page appears.

## Specifying the Adapter Interface

The screenshot shows a wizard window titled "FILE Adapter Configuration Wizard - Step 3 of 7". The main heading is "Adapter Interface". Below the heading, there is a descriptive paragraph: "The adapter interface is defined by a wsdl that is generated using the operation name and schema(s) specified later in this wizard. Optionally, the adapter interface may be defined by importing an existing WSDL." Below this text, there are two radio buttons under the label "Interface:". The first radio button is selected and labeled "Define from operation and schema (specified later)". The second radio button is labeled "Import an existing WSDL". Below the radio buttons, there are three input fields: "WSDL URL:" with a text box and a file icon, "Port Type:" with a dropdown menu, and "Operation:" with a dropdown menu. At the bottom of the window, there are four buttons: "Help", "< Back", "Next >", "Finish", and "Cancel".

Select the **Define from operation and schema (specified later)** radio button and click **Next**.

5. In the Operation page, specify the operation type. For example, select the **Write File** radio button. This automatically populates the **Operation Name** field.

## Specifying the Operation

**Operation**

The File Adapter supports four operations. There is a Read File operation that polls for incoming files in your local file system, a Write File operation that creates outgoing files, a Synchronous Read File operation that reads the current contents of a file, and a List Files operation that lists file names in specified locations. Specify the Operation type and Operation Name. Only one operation per Adapter Service may be defined using this wizard.

Operation Type:  Read File  
 Write File  
 Synchronous Read File  
 List Files

Operation Name:

Add Output Header

Help < Back Next > Finish Cancel

6. Click **Next** to access the File Configuration page.



## Configuring the Output File

The screenshot shows the 'FILE Adapter Configuration Wizard - Step 5 of 7' window. The title bar includes a close button (X). The main window has a header 'File Configuration' and a sub-header 'Specify the parameters for the Write File operation.' Below this, there are two radio buttons: 'Physical Path' (unselected) and 'Logical Name' (selected). A text box labeled 'Directory for Outgoing Files (logical name):' contains the text 'OutputDir'. Below that, another text box labeled 'File Naming Convention (po\_%SEQ%.txt):' contains the text 'EventAck%yyMMddHHmmss%.xml'. There is a checkbox for 'Append to existing file' which is unchecked. A section titled 'Write to output file when any of these conditions are met' contains three rows: 'Number of Messages Equals:' with a value of '1' and a spinner; 'Elapsed Time Exceeds:' with a value of '1' and a unit dropdown set to 'minutes'; and 'File Size Exceeds:' with a value of '1000' and a unit dropdown set to 'kilobytes'. At the bottom, there are four buttons: 'Help', '< Back', 'Next >', and 'Cancel'.

7. For the **Directory specified as** field, select the **Logical Name** radio button. Enter `outputDir` as the **Directory for Outgoing Files (logical name)** and specify a naming convention for the output file, such as `EventAck%yyMMddHHmmss%.xml`.

**Tip:** When you type a percent sign (%), you can choose from a list of date variables or a sequence number variable (SEQ) as part of the filename.

Confirm the default write condition: **Number of Messages Equals 1**.

8. Click **Next**, and the Messages page appears. For the output file to be written, you must provide a schema.
9. Click **Browse** to access the Type Chooser.
10. Expand the node by clicking **Project Schema Files > ViewAck\_table.xsd** and selecting **OeHeaderAcksVCollection**. Click **OK**.

The selected schema information will be automatically populated in the URL and

Schema Element fields.

### Populating the Selected Message Schema

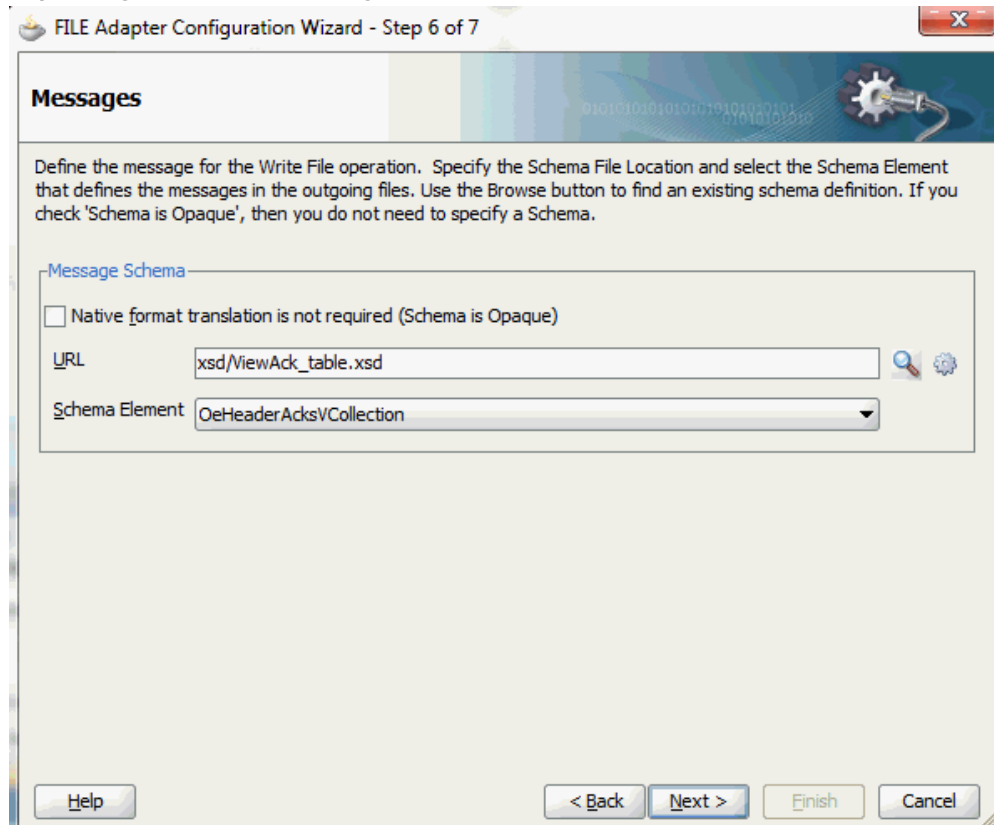

11. Click **Next** and then **Finish**. The wizard generates the WSDL file corresponding to the partner link. The main Create Partner Link dialog box appears, specifying the new WSDL file.
12. Click **Apply** and then **OK** to complete the configuration and create the partner link with the required WSDL settings for the File Adapter service.

### Completing the Partner Link Configuration

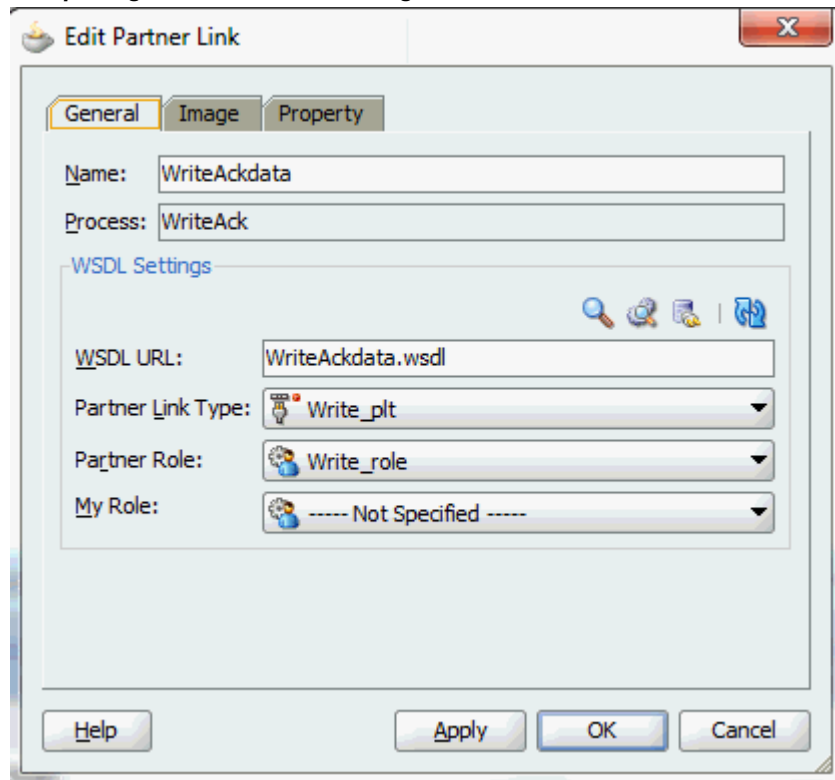

## Configuring Invoke Activities

Based on the scenario described earlier, you need to configure the following two Invoke activities:

1. To get the purchase order acknowledgement details by invoking the `ViewAck` partner link.
2. To write the purchase order acknowledgement information to an XML file by invoking `WriteAckdata` partner link for File Adapter.

### To add the first Invoke activity for a partner link to get acknowledgement details:

1. In Oracle JDeveloper BPEL Designer, expand the **BPEL Constructs** from the Component Palette. Drag and drop the first **Invoke** activity into the center swim lane of the process diagram, between the **receiveInput** and **callbackClient** activities.
2. Link the Invoke activity to the `ViewAck` service. The Edit Invoke dialog appears. The value of the Operation field is automatically selected based on the associated

partner link. For example, this Invoke activity is associated with an interface table partner link for 'select' operation only, the 'ViewAckSelect' service name with 'Select' operation is populated as the value.

3. Enter a name for the Invoke activity, then click the **Create** icon next to the **Input Variable** field to create a new variable. The Create Variable dialog box appears.
4. Select **Global Variable**, then enter a name for the variable. You can also accept the default name.

Click **OK**.

5. Click the **Create** icon next to the **Output Variable** field to create a new variable. The Create Variable dialog box appears.
6. Select **Global Variable**, then enter a name for the variable. You can also accept the default name.

Click **OK** to close the Create Variable dialog.

The screenshot shows the 'Edit Invoke' dialog box with the following configuration:

- Name:** Invoke
- Conversation ID:** (empty)
- Detail Label:** (empty)
- Invoke as Detail
- Interaction Type:** Partner Link
- Partner Role Web Service Interface:**
  - Partner Link:** ViewAck
  - Operation:** ViewAckSelect
- Variables:**
  - Input:** Invoke\_ViewAckSelect\_InputVariable
  - Output:** Invoke\_ViewAckSelect\_OutputVariable

Click **Apply** and then **OK** in the Edit Invoke dialog box to finish configuring the Invoke activity.

The Invoke activity appears in the process diagram.

**To add the second Invoke activity for a File Adapter partner link to write acknowledgement details in an XML file:**

1. In Oracle JDeveloper BPEL Designer, expand the **BPEL Constructs** from the Component Palette. Drag and drop the first **Invoke** activity into the center swim lane of the process diagram, right after the first **Invoke** activity.
2. Link the Invoke activity to the `WriteAckdata` service for File Adapter. The Edit Invoke dialog appears.
3. Enter a name for the Invoke activity, then click the **Create** icon next to the **Input Variable** field to create a new variable. The Create Variable dialog appears.
4. Select **Global Variable**, then enter a name for the variable. You can also accept the default name. Click **OK** to return to the Edit Invoke dialog box.

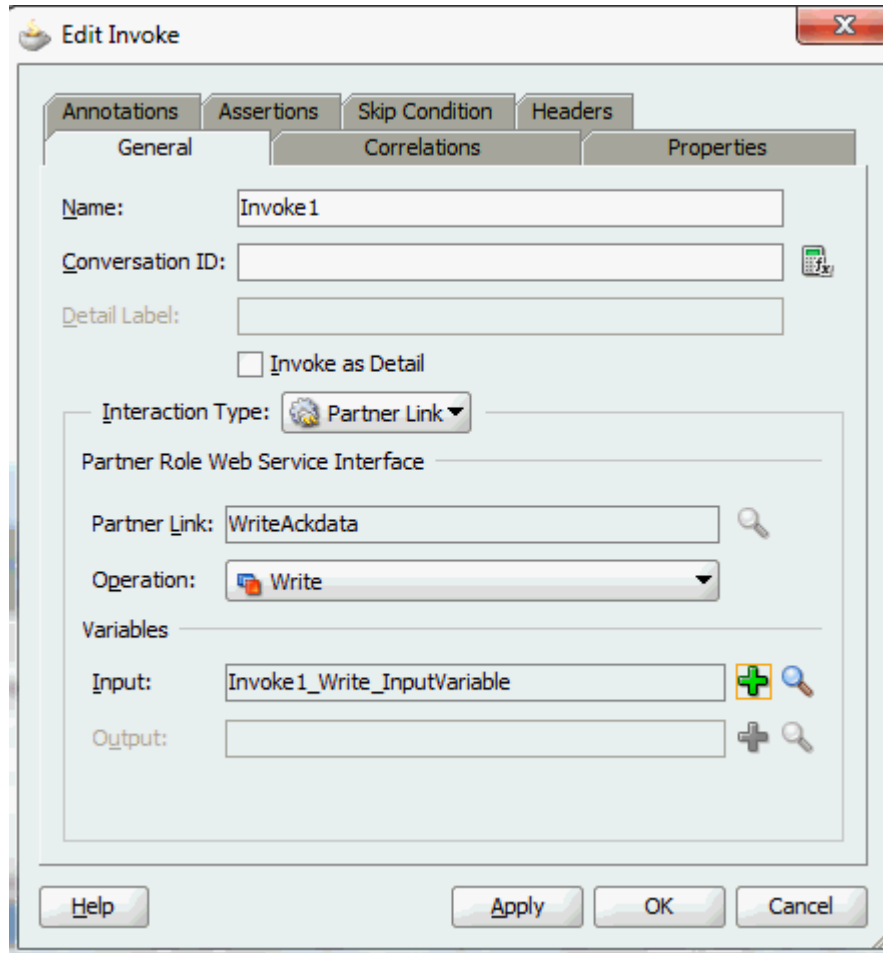

Click **Apply** and then **OK** to finish configuring the Invoke activity.  
The second Invoke activity appears in the process diagram.

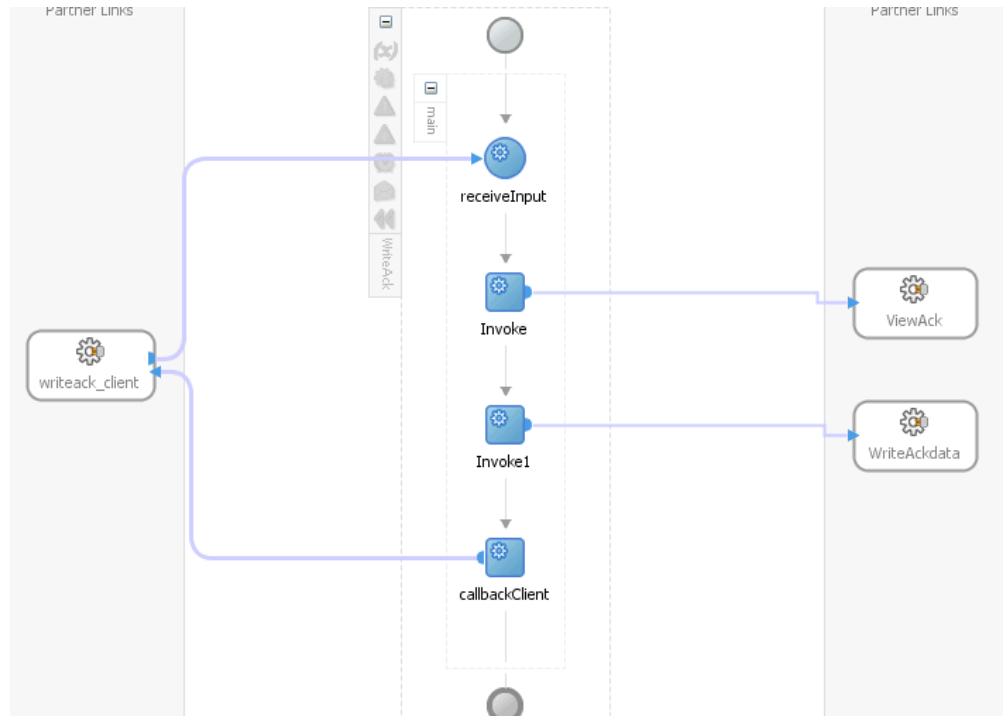

## Configuring an Assign Activity

The next task is to add an Assign activity to the process map. This is used to provide values to the input variables.

### To configure an Assign activity:

1. In Oracle JDeveloper BPEL Designer, expand the **BPEL Constructs** from the Component Palette.

Drag and drop the **Assign** activity into the center swim lane of the process diagram between the two **Invoke** activities that you just created earlier.

2. Double-click the **Assign** activity to access the Edit Assign dialog.

Click the General tab to enter a name for the Assign activity. For example, setAckdata.

3. Select the Copy Rules tab and expand the target trees:
  - In the From navigation tree, navigate to **Variable > Process > Variables > Invoke\_ViewAckSelect\_OutputVariable** and select **OeHeaderAcksVCollection**.
  - In the To navigation tree, navigate to **Variable > Process > Variables >**

**Invoke1\_Write\_InputVariable** and select **body**.

Drag the source node (OeHeaderAcksVCollection) to connect to the target node (body) that you just specified. This creates a line that connects the source and target nodes. The copy rule is displayed in the From and To sections at the bottom of the Edit Assign dialog box.

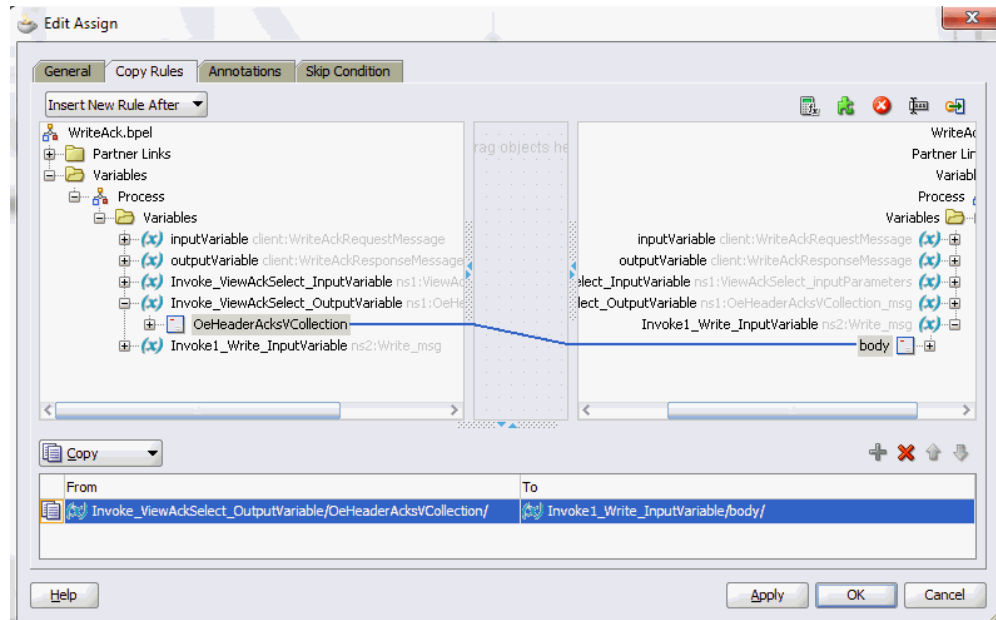

Click **Apply** and then **OK**.

The BPEL diagram is completed.



### BPEL Process Diagram

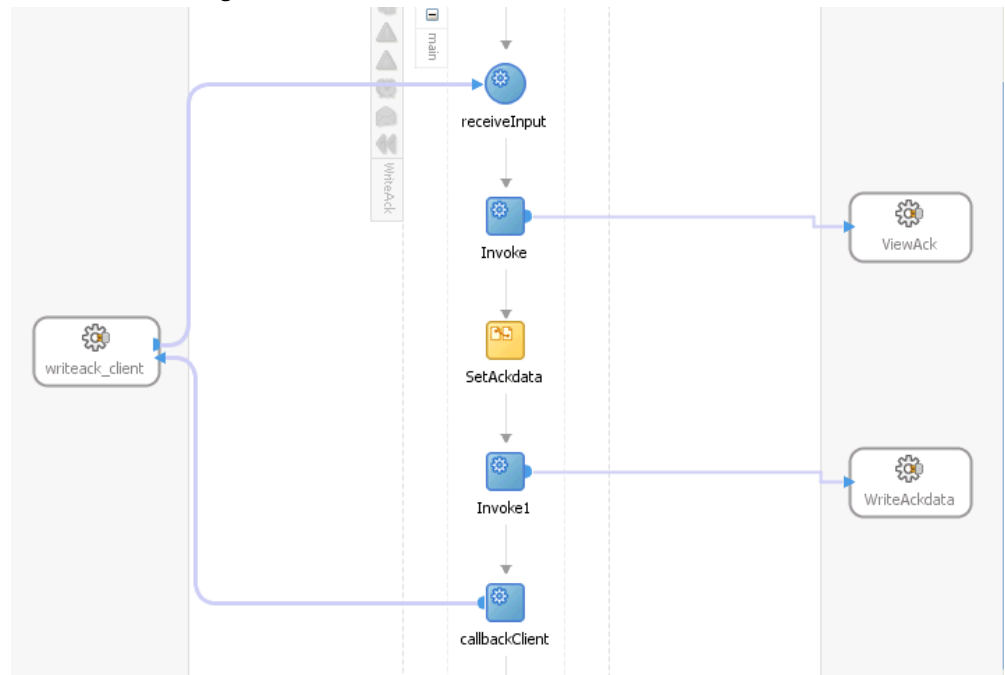

Click the `composite.xml` to display the Oracle JDeveloper composite diagram:

**Note:** Click the Source tab of `composite.xml` to enter a value for the physical directory `outputDir` for the reference `WriteAckdata` (such as `/usr/tmp`).

```
<property name="outputDir" type="xs:string"
many="false" override="may">/usr/tmp</property>
```

## Specifying the Physical Directory for the Property

```
<component name="WriteAck" version="1.1">
  <implementation.bpel src="WriteAck.bpel"/>
  <property name="bpel.config.oneWayDeliveryPolicy" type="xs:string"
    many="false">async.persist</property>
</component>
<reference name="ViewAck" ui:wSDLLocation="ViewAck.wsdl">
  <interface.wSDL interface="http://xmlns.oracle.com/pcbpel/adapter/apps/WriteAck-App/WriteAck"
  <binding.jca config="ViewAck_apps.jca"/>
  <property name="jca.retry.count" type="xs:int" many="false" override="may">4</property>
  <property name="jca.retry.interval" type="xs:int" many="false"
    override="may">1</property>
  <property name="jca.retry.backoff" type="xs:int" many="false"
    override="may">2</property>
  <property name="jca.retry.maxInterval" type="xs:string" many="false"
    override="may">120</property>
</reference>
<reference name="WriteAckdata" ui:wSDLLocation="WriteAckdata.wsdl">
  <interface.wSDL interface="http://xmlns.oracle.com/pcbpel/adapter/file/WriteAck-App/WriteAck"
  <binding.jca config="WriteAckdata_file.jca"/>
  <property name="OutputDir" type="xs:string" many="false" override="may">/usr/tmp/</property>
</reference>
<wire>
  <source.uri>writeack_client_ep</source.uri>
  <target.uri>WriteAck/writeack_client</target.uri>
</wire>
</wire>
```

## Oracle JDeveloper Composite Diagram

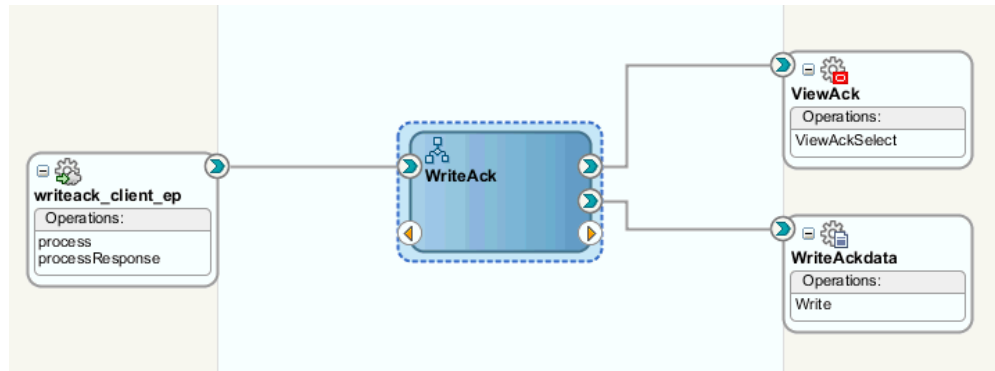

## Run-Time Tasks for Views

After designing the SOA Composite application with BPEL process, the next steps are to deploy, run and monitor it.

1. Deploy the SOA Composite application with BPEL process, page 8-72
2. Test the deployed SOA Composite application with BPEL process, page 8-77

## Deploying the SOA Composite Application with BPEL Process

To invoke the service from the BPEL client contained in the SOA composite, the SOA

composite needs to be deployed to the Oracle WebLogic managed server. This can be achieved using Oracle JDeveloper. Once the composite is deployed, it can be tested from the Oracle Enterprise Manager Fusion Middleware Control Console.

### **Prerequisites**

Before deploying the SOA composite with BPEL process using Oracle JDeveloper, you must have established the connectivity between the design-time environment and the run-time server. For more information, see *Configuring the Data Source in Oracle WebLogic Server*, page A-3 and *Creating an Application Server Connection*, page A-12.

**Note:** If a local instance of the WebLogic Server is used, start the WebLogic Server by selecting **Run > Start Server Instance** from Oracle JDeveloper. Once the WebLogic Admin Server "DefaultServer" instance is successfully started, the <Server started in Running mode> and DefaultServer started message in the Running:DefaultServer and Messages logs should appear.

### **To deploy the SOA Composite application with BPEL process:**

1. Select the SOA Composite project in the Applications Navigator.
2. Right-click the project name, and then select **Deploy > [project name] > [serverConnection]** from the menu that appears.

For example, you can select **Deploy > WriteAck > soa-server1** to deploy the process if you have the connection set up appropriately.

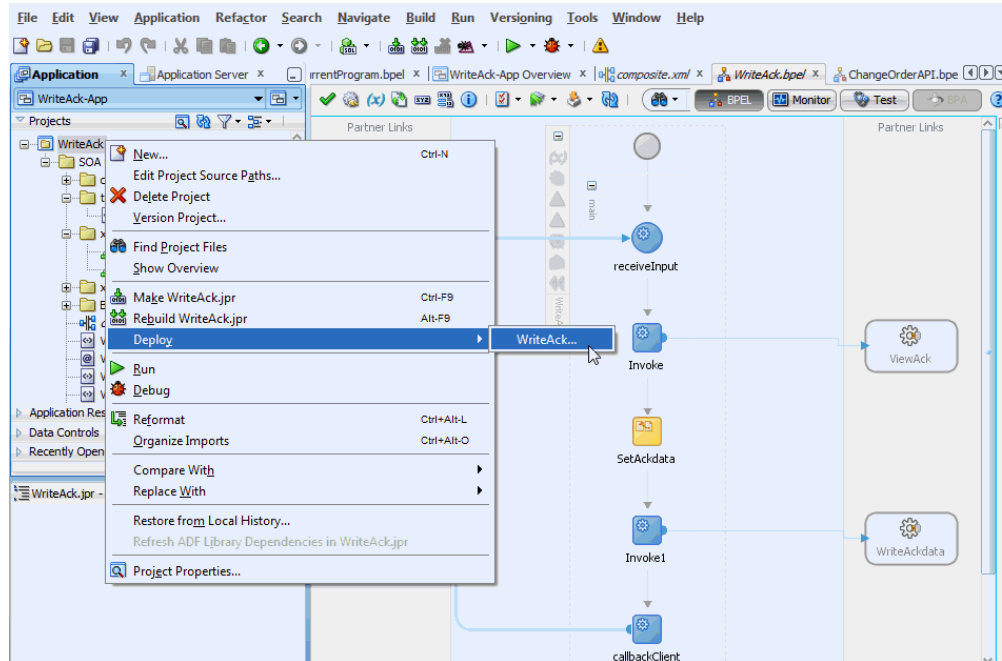

**Note:** If this is the first time to set up server connection, then the Deployment Action window appears. Select 'Deploy to Application Server' and click **Next**.

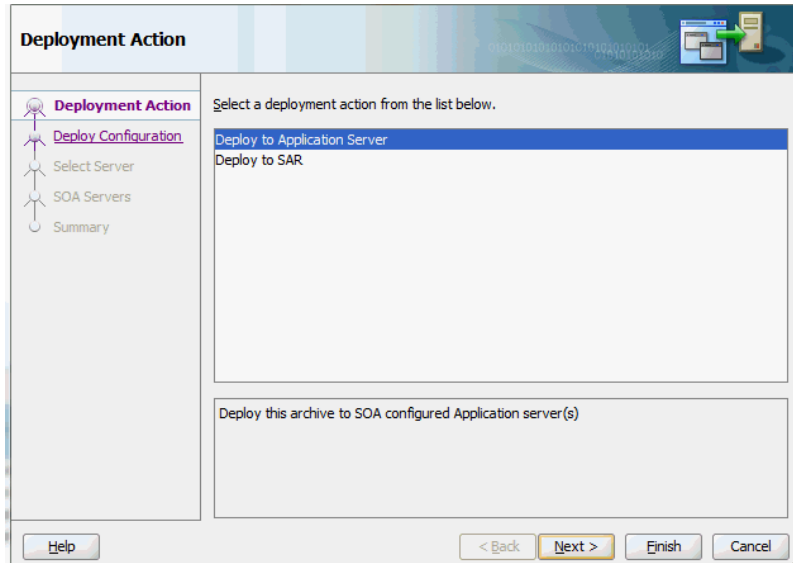

In the Deploy Configuration window, ensure the following information is selected before clicking **Next** to add a new application server:

- New Revision ID: 1.0
- Mark composite revision as default: Select this check box.
- Overwrite any existing composites with the same revision ID: Select this check box.

The steps to create a new Oracle WebLogic Server connection from JDeveloper are covered in [Creating an Application Server Connection](#), page A-12.

3. In the Select Server page, select 'soa-server1' that you have established the server connection earlier. Click **Next**.

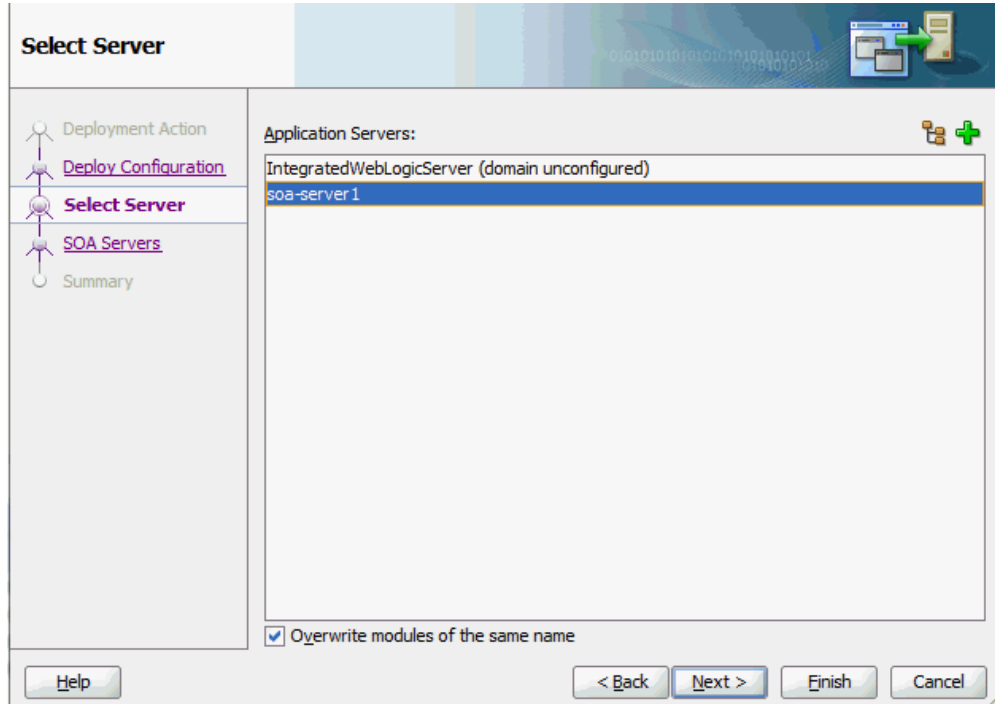

4. In the SOA Servers page, accept the default target SOA Server ('soa-server1') selection.

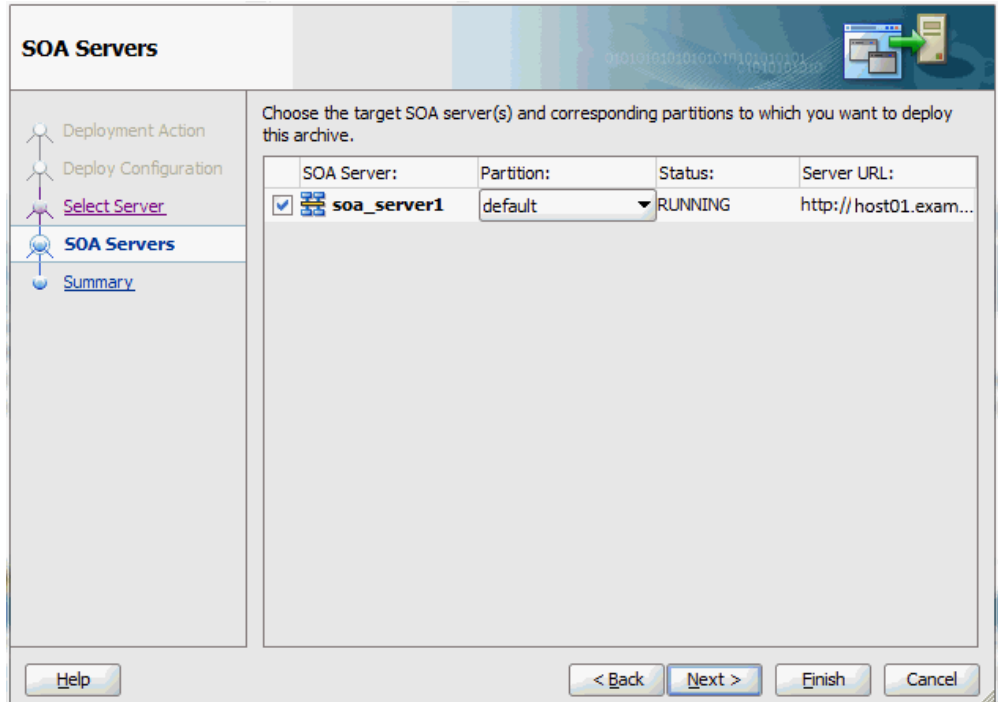

Click **Next** and **Finish**.

If you are deploying the composite for the first time from your Oracle JDeveloper session, the Authorization Request window appears. Enter username and password information specified during Oracle SOA Suite installation. Click **OK**.

5. The BPEL process contained in the SOA Composite application is compiled and deployed. You can check the progress of the compilation in the Messages window.

## Testing the Deployed SOA Composite Application with BPEL Process

Once the SOA Composite application is deployed, you can manage and monitor the process from the Oracle Enterprise Manager Fusion Middleware Control Console. You can also test the process and the integration interface by manually initiating the process.

### To manually initiate and monitor the deployed SOA Composite application with BPEL process:

1. Navigate to Oracle Enterprise Manager Fusion Middleware Control Console (`http://<servername>:<portnumber>/em`). The composite you deployed is displayed in the Applications Navigation tree.

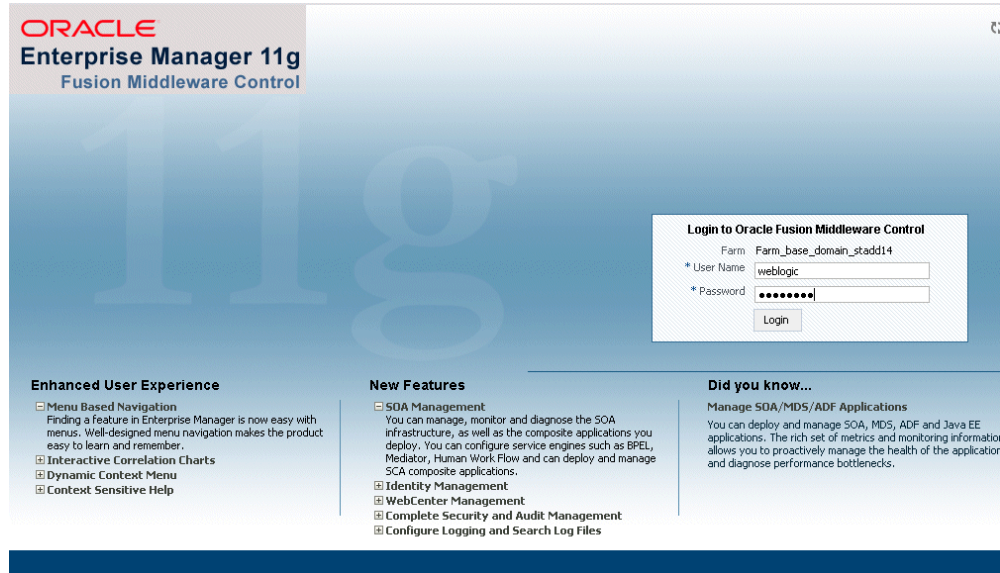

2. Enter username (such as `weblogic`) and password and click **Login** to log in to a farm.

You may need to select an appropriate target instance farm if there are multiple target Oracle Enterprise Manager Fusion Middleware Control Console farms.

3. From the Farm base domain, expand the **SOA >soa-infra** to navigate through the SOA Infrastructure home page and menu to access your deployed SOA Composite applications running in the SOA Infrastructure for that managed server.

**Note:** The Farm menu always displays at the top of the navigator. As you expand the SOA folder in the navigator and click the links displayed beneath it, the SOA Infrastructure menu becomes available at the top of the page.

Click the SOA Composite application that you want to initiate (such as 'WriteAck') from the SOA Infrastructure.

Click **Test** at the top of the page.

4. The Test Web Service page for initiating an instance appears. You can specify the XML payload data to use in the Input Arguments section.

Enter the input string required by the process and click **Test Web Service** to initiate the process.



## Testing Web Service

Name	Type	Value
* payload	payload	
* input	string	test

The test results appear in the Response tab upon completion.

5. Click on the SOA Composite application name and then click the Instances tab. The SOA Composite application instance ID, name, conversation ID, most recent known state of each instance since the last data refresh of the page are displayed.

In the Instance ID column, click a specific instance ID to show the message flow through the various service components and binding components. The Flow Trace page is displayed.

In the Trace section, you should find the sequence of the message flow for the service binding component (`writeack_client_ep`), BPEL component (`WriteAck`), and reference binding components (`ViewAck` and `WriteAckdata`). All involved components have successfully received and processed messages.

If any error occurred during the test, you should find it in the Faults section.

6. Click your BPEL service component instance link (such as `WriteAck`) to display the Instances page where you can view execution details for the BPEL activities in the Audit Trail tab.

Click the Flow tab to check the BPEL process flow diagram. Click an activity of the process diagram to view the activity details and flow of the payload through the process.

## 7. Verifying Records in Oracle Applications

Log on to Oracle Applications with Purchasing, Vision Operations (USA) responsibility and select Purchase Order from the navigation menu.

The Oracle Applications Forms open up with the Purchase Order forms.

8. Create a purchase order with the following header values:
  - Supplier: Enter a supplier information, such as 'Advanced Network Devices'.
  - Site: Select a site information, such as 'SANTA CLARA-ERS'.
9. On the Lines tab, enter a data row with the following values:
  - Type: Goods
  - Item: CM13139
  - Quantity: 1
  - Description: Hard Drive - 8GB
  - Promised: Enter any future date in the format of dd-mmm-yyyy (such as 23-JUN-2009)
10. Save your purchase order. The status of the purchase order is 'Incomplete'.
11. Click **Approve**. The Approve Document form appears.  
Click **OK** to confirm the approval.

**Note:** Because the trading partner is set up and valid, the transmission method is automatically set to **XML**.

Purchase Orders - 5789

Operating Unit: Vision Operations | Created: 07-JUN-2008 01:29:02

PO, Rev: 5789 | Type: Standard Purchase Order

Supplier: Advanced Network Devices | Site: SANTA CLARA-ERS

Ship-To: M1- Seattle Mfg | Bill-To: V1- New York City

Buyer: Stock, Ms. Pat | Status: Approved

P-Card: | Contact: | Currency: USD | Total: 150.39

Num	Type	Item	Rev	Job	Category	Description	UOM	Quantity	Price
1	Goods	CM13139			PRODUCTN.DRN	Hard Drive - 8GB	Each	1	150.393

Item: CM13139 | Hard Drive - 8GB

Buttons: Catalog..., Currency..., Terms, Shipments, Approve...

The status of the purchase order is now changed to 'Approved'. For future reference, note the value of the PO, Rev field. For example, the PO number 5789.

Once the purchase order is approved, the order details should be recorded in the system.

After deploying the BPEL process contained in a SOA Composite application, the order acknowledgement information should be retrieved from the OE\_HEADER\_ACKS\_V and OE\_LINE\_ACKS\_V interface views.

Validate the output file `EventAck%yyMMddHHmss%.xml` in the specified output directory by opening the xml file to confirm the purchase order details. The document number in the xml file should be the same number you just approved in Oracle Applications.



---

## Using PL/SQL APIs

This chapter covers the following topics:

- Overview of PL/SQL APIs
- Design-Time Tasks for PL/SQL APIs
- Creating a New SOA Composite Application with BPEL Process
- Adding Partner Links
- Adding a Partner Link for File Adapter
- Defining Wrapper APIs
- Declaring Parameters with a DEFAULT Clause
- Configuring the Invoke Activities
- Configuring a Transform Activity
- Configuring an Assign Activity
- Run-Time Tasks for PL/SQL APIs
- Deploying the SOA Composite Application with BPEL Process
- Testing the Deployed SOA Composite Application with BPEL Process
- Troubleshooting

### Overview of PL/SQL APIs

Adapter for Oracle Applications uses PL/SQL application programming interfaces (APIs) to insert and update data in Oracle Applications. APIs are stored procedures that enable you to insert and update data in Oracle Applications. Additionally, you can use PL/SQL APIs to retrieve data. For example, by using PL/SQL APIs, you can insert a customer record in Oracle Applications.

**Note:** For more information about PL/SQL procedure limitations, refer

## Design-Time Tasks for PL/SQL APIs

This section describes how to configure the Adapter for Oracle Applications to use PL/SQL APIs. It describes the tasks required to configure Adapter for Oracle Applications using the Adapter Configuration Wizard in Oracle JDeveloper.

### SOA Composite Application with BPEL Process Scenario

In this example, Adapter for Oracle Applications exposes the following stored procedures as Web services in a BPEL process to update the 'quantity' field of an existing purchase order based on user input.

- A custom Order Management stored procedure `GET_G_MISS_LINE_REC` (`GET_G_MISS_LINE_REC`) to initialize the purchase order
- A PL/SQL Process Order Line (`PROCESS_LINE`) to update the existing purchase order

When a change order request is received, the purchase order information including order quantity and other line item details will be retrieved. Based on user input, a new order quantity will be updated in Oracle Order Management.

When the SOA Composite application with BPEL process has been successfully executed after deployment, you can validate the process by querying it directly from Order Management tables or validate it from the Form-based Oracle Order Management application. The retrieved `ordered_quantity` value from the query table or you find in the Order Management application should be the same as the quantity value given by the user through `changeorder_data.xml` file.

### Prerequisites to Configure PL/SQL APIs

Adapter for Oracle Applications is deployed using the BPEL Process Manager (PM) in Oracle JDeveloper. The BPEL PM creates the WSDL interfaces for the API.

### *Populating Applications Context Header Variables*

You need to populate certain variables in the BPEL PM in order to provide context information for Oracle Applications. The context information is required for an API transaction in order for an Oracle Applications user that has sufficient privileges to run the program.

The context is set taking into account the values passed for the header properties including *Username*, *Responsibility*, *Responsibility Application*, *Security Group*, and *NLS Language*. If the values for the new header properties *Responsibility Application*, *Security Group*, and *NLS Language* are not passed, context information will be determined based on *Username* and *Responsibility*.

The default Username is `SYSADMIN`, the default Responsibility is `SYSTEM`

ADMINISTRATOR, the default Security Group Key is Standard, and the default NLS Language is US.

You can change the default values specified in the generated WSDL. This is a static way of changing the context information. These values would apply to all invocations of the deployed business process. However, if you need to provide different context information for different invocations of the business process, then you can dynamically populate the header values. The context information can be specified by configuring an Invoke activity.

For more information about applications context, see Supporting for Normalized Message Properties, page 4-7.

### *Populating Default Values for Record Types*

Certain PL/SQL APIs exposed from Oracle E-Business Suite take record types as input. Such APIs expect default values to be populated for parameters within these record types for successful execution.

The default values are FND\_API.G\_MISS\_CHAR for characters, FND\_API.G\_MISS\_DATE for dates, and FND\_API.G\_MISS\_NUM for numbers. Adapter for Oracle Applications can default these values when the parameters within the record type are passed as nil values, for example, as shown below:

```
<PRICE_LIST_REC>
<ATTRIBUTE1 xsi:nil="true"/>
<ATTRIBUTE2 xsi:nil="true"/>
<ATTRIBUTE3 xsi:nil="true"/>
...
</PRICE_LIST_REC>
```

This can be achieved with the help of a function in a Transform activity, or by directly passing the XML input with nil values and then assigning them to the record types within an Assign activity.

Following is a list of the procedures required to accomplish the design-time tasks.

1. Create a new SOA Composite application with BPEL process, page 9-4
2. Add partner links, page 9-8
3. Add a partner link for File Adapter, page 9-20
4. Define wrapper APIs, page 9-26
5. Declare parameters with a DEFAULT clause, page 9-29
6. Configure Invoke activities, page 9-32
7. Configure a Transform activity, page 9-36
8. Configure an Assign activity, page 9-39

## Creating a New SOA Composite Application with BPEL Process

To create a new SOA Composite application with BPEL process:

1. Launch Oracle JDeveloper.
2. Click **New Application** in the Application Navigator.

The Create SOA Application - Name your application page is displayed.

### The Create SOA Application - Name your application Page

Application Name:  
ChangeOrderAPI-App

Directory:  
C:\JDeveloper\mywork\ChangeOrderAPI-App Browse...

Application Package Prefix:

Application Template:

- Java Desktop Application (ADF)  
Creates a databound rich client application. The application consists of one project for the client (ADF Swing), and another project for the ADF Model (ADF Business Components).
- Java EE Web Application  
Creates a databound web application. The application consists of one project for the view and controller components (JSF), and another project for the data model (EJB session beans and JPA entities).
- SOA Application**  
Creates a SOA (service-oriented architecture) application. The application consists of one SOA project for the SOA composite, components, and adapters.

Help < Back Next > Finish Cancel

3. Enter an appropriate name for the application in the **Application Name** field and select **SOA Application** from the Application Template list.

Click **Next**. The Create SOA Application - Name your project page is displayed.

4. Enter an appropriate name for the project in the **Project Name** field. For example, ChangeOrderAPI.



### The Create SOA Application - Name your project Page

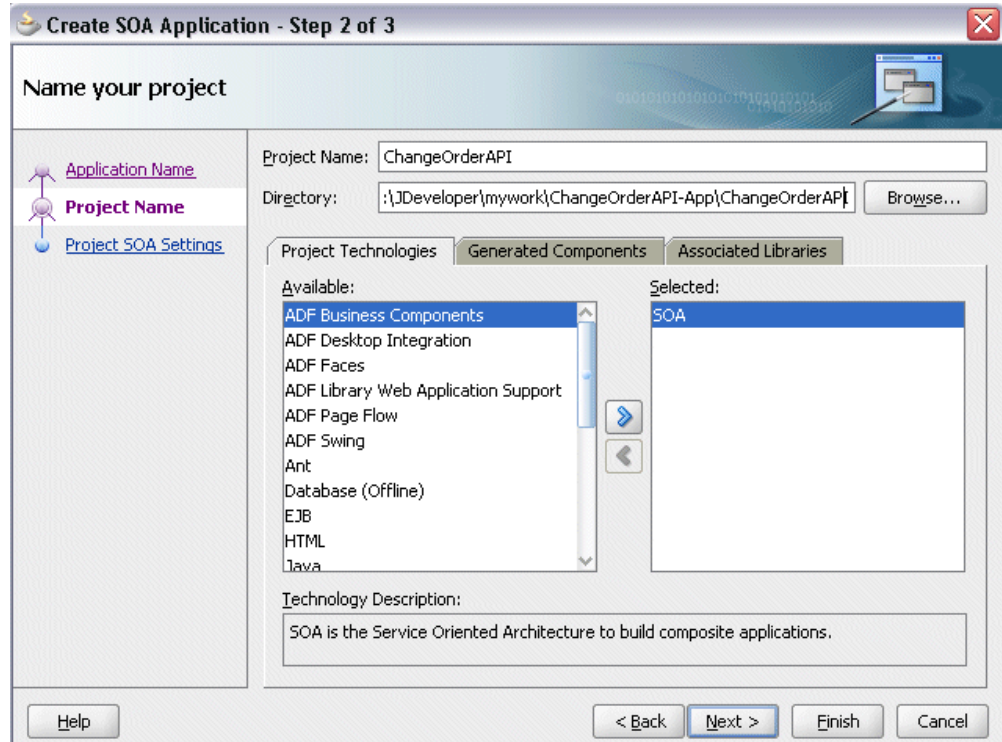

5. In the Project Technologies tab, ensure that **SOA** is selected from the Available technology list to the Selected technology list.

Click **Next**. The Create SOA Application - Configure SOA settings page is displayed.

### The Create SOA Application - Configure SOA settings Page

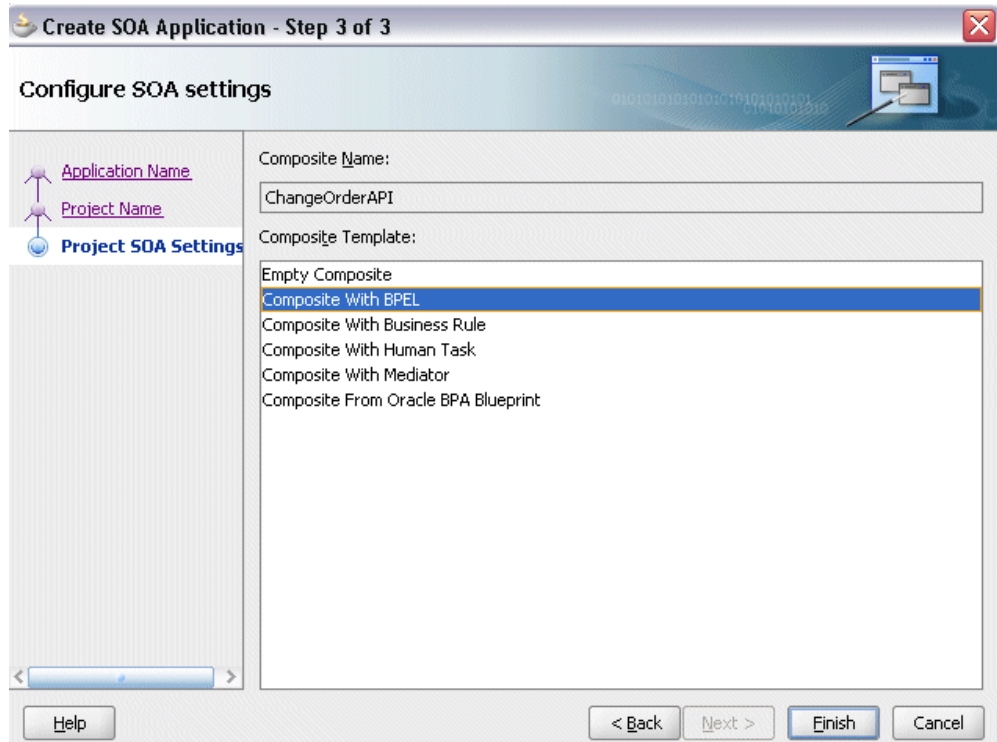

6. Select **Composite With BPEL** from the Composite Template list, and then click **Finish**. You have created a new application, and a SOA project. This automatically creates a SOA Composite application.

The Create BPEL Process page is displayed.

### The Create BPEL Process Page

**BPEL Process**

A BPEL process is a service orchestration, based on the BPEL specification, used to describe/execute a business process (or large grained service), which is implemented as a stateful service.

BPEL 1.1 Specification  BPEL 2.0 Specification

Name:

Namespace:

Template:

Service Name:

Expose as a SOAP service

Delivery:

Input:

Output:

Help OK Cancel

7. Leave the default **BPEL 1.1 Specification** selection unchanged. This creates a BPEL project that supports the BPEL 1.1 specification.

Enter an appropriate name for the BPEL process in the **Name** field. For example, `ChangeOrderAPI`.

Select **Asynchronous BPEL Process** in the **Template** field. Click **OK**.

An asynchronous BPEL process is created with the Receive and Reply activities. The required source files including `bpel` and `wSDL`, using the name you specified (for example, `ChangeOrderAPI.bpel` and `ChangeOrderAPI.wSDL`) and `composite.xml` are also generated.

8. Navigate to SOA Content > Business Rules and click `composite.xml` to view the composite diagram.

Double click on the `ChangeOrderAPI` component to open the BPEL process.

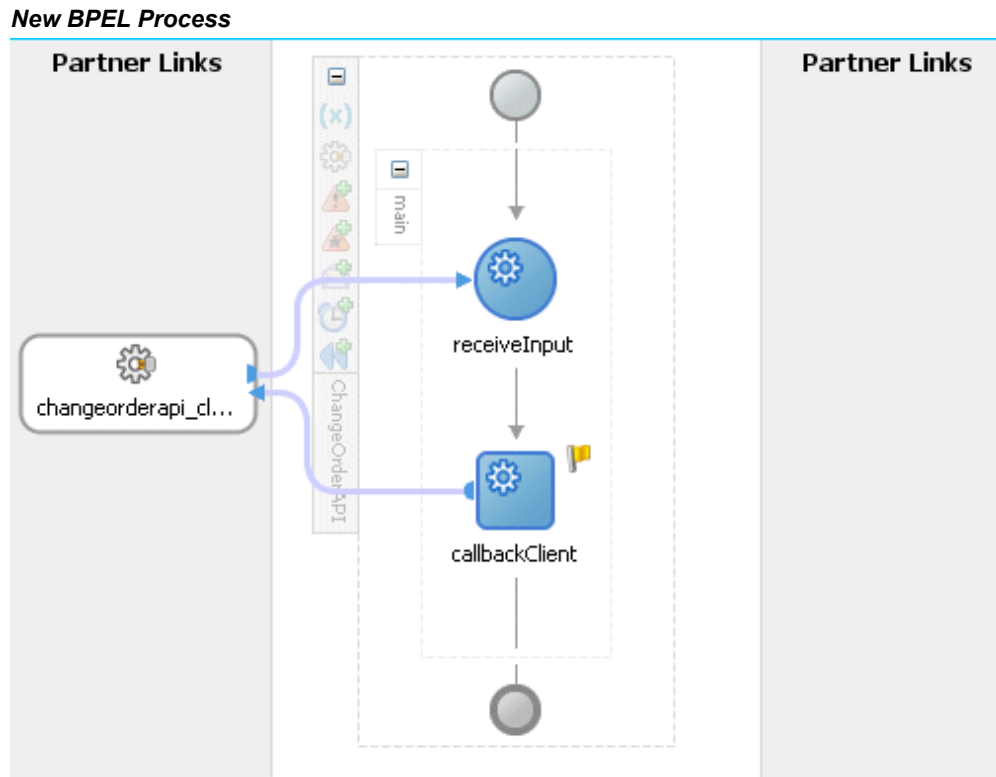

## Adding Partner Links

The next task is to add a partner link to the BPEL process. This section describes how to create an Oracle Applications adapter for the application service by adding a partner link to your BPEL process. A BPEL partner link defines the link name, type, and the role of the BPEL process that interacts with the partner service.

Based on the BPEL process scenario discussed earlier, the following two partner links need to be configured:

- Add the first partner link (`initLineRec`) to initialize the purchase order
- Add the second partner link (`OrderManagement`) to update the existing purchase order

### To add the first partner link:

1. Click **BPEL Services** in the Component Palette.

Drag and drop **Oracle Applications** from the **BPEL Services** list into the right Partner Link swim lane of the process diagram. The Adapter Configuration Wizard Welcome page appears. Click **Next**.

2. Enter a service name in the **Service Name** field. For example, `initLineRec`. Click **Next**. The Service Connection dialog appears.
3. You can perform either one of the following options for your database connection:

**Note:** You need to connect to the database where Oracle Applications is running.

- You can create a new database connection by clicking the **Create a New Database Connection** icon.

How to define a new database connection, see *Create a New Database Connection*, page 5-13.

- You can select an existing database connection that you have configured earlier from the **Connection** drop-down list.

The Service Connection page will be displayed with the selected connection information. The JNDI (Java Naming and Directory Interface) name corresponding to the database connection appears automatically in the **Database Server JNDI Name** field. Alternatively, you can specify a JNDI name.

**Note:** When you specify a JNDI name, the deployment descriptor of the Oracle Applications adapter must associate this JNDI name with configuration properties required by the adapter to access the database.

The JNDI name acts as a placeholder for the connection used when your service is deployed to the BPEL server. This enables you to use different databases for development and later for production.

**Note:** For more information about JNDI concepts, refer to *Oracle Fusion Middleware User's Guide for Technology Adapters*.

4. Once you have completed creating a new connection for the service, you can add a PL/SQL API by browsing through the list of APIs available in Oracle Applications. Click **Next**.

**For Oracle E-Business Suite Release 12:**

If you are connecting to Oracle E-Business Suite Release 12, then the **IREP File not present** dialog appears indicating that Adapter could not find the Oracle Integration Repository data file corresponding to the database you are connecting to Oracle Applications in your workspace. Absence of the data file would make browsing or searching of Integration Repository tree considerably slow. You can

choose to extract the data file and create a local copy of the Integration Repository data file. Once it is created successfully, Adapter will pick it up automatically next time and retrieve data from your local Integration Repository.

You can select one of the following options:

- Click **Yes** to extract the Integration Repository data file.

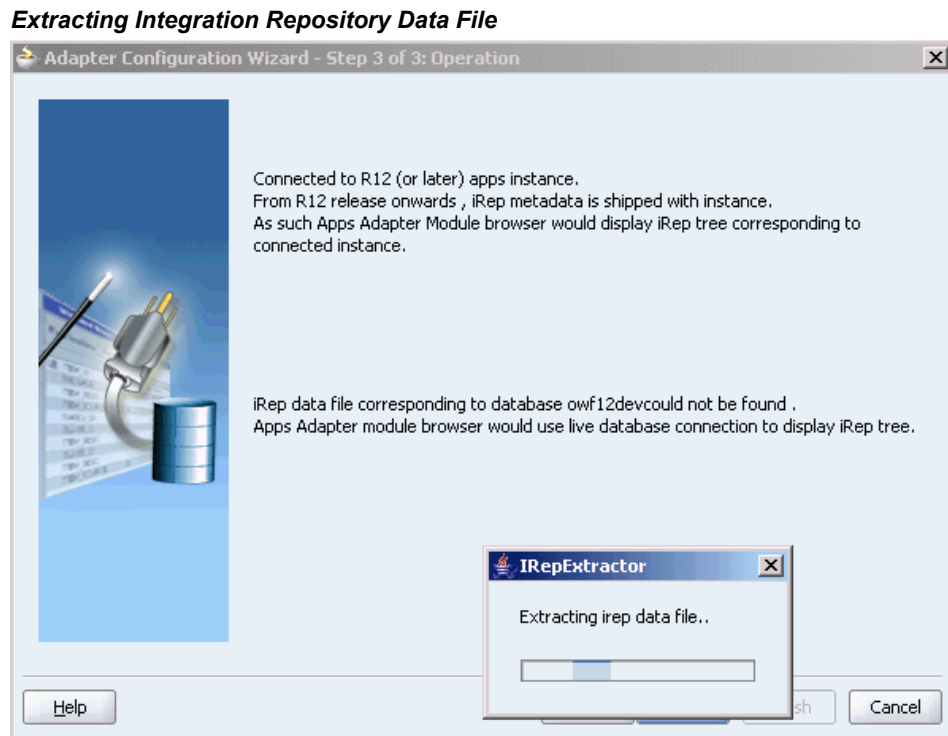

After the system successfully creates a local copy of the Integration Repository data file, next time when you connect to the database, you will find the **IRep Data File** field appears in the Operation dialog indicating where your local copy exists with the creation date and time as part of the file name.

### Using the Local Integration Repository Data File

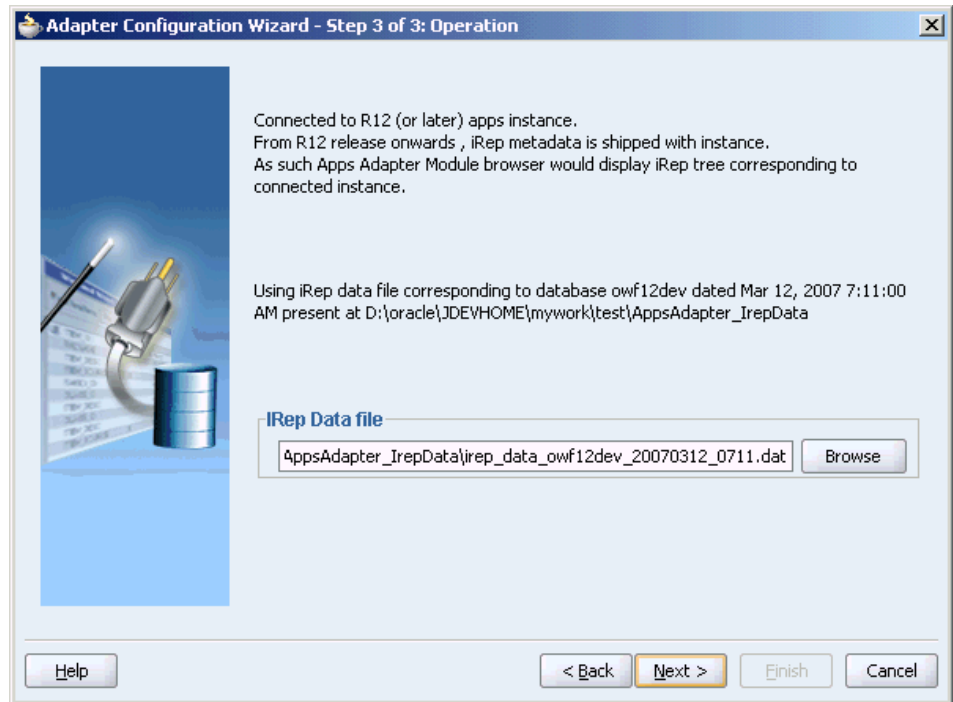

- Click **No** to query the Integration Repository data file from the live database you are connecting to display the Integration Repository tree.

Click **Next** in the Operation page to open the Oracle Applications Module Browser.

#### For Oracle E-Business Suite Release 11.5.9:

If you are connecting to an Oracle E-Business Suite Release 11.5.9 instance, you must select the interface type in the Adapter Configuration Wizard. Select **Tables/Views/APIs/Concurrent Programs** to proceed.

Click **Get Object** in the Application Interface dialog to open the Oracle Applications Module Browser.

5. The Oracle Applications Module Browser combines interface data from Oracle Integration Repository with information about the additional interfaces supported by Adapter for Oracle Applications, organized in a tree hierarchy.

**Note:** The Oracle Applications Module Browser includes the various product families that are available in Oracle Applications. Each product family contains the individual products. Each product contains the business entities associated with the product.

Business entities contain the various application modules that are exposed for integration. These modules are grouped according to the interface they provide. PL/SQL APIs can be found under the PL/SQL category.

Navigate to *Other Interfaces > Custom Objects > PLSQL APIs > OE\_ORDER\_PUB* to select a custom stored procedure `GET_G_MISS_LINE_REC`.

**Note:** The `GET_G_MISS_LINE_REC` (`GET_G_MISS_LINE_REC`) stored procedure does not take any input but has a complex data type (PL/SQL Table) as output. Adapter for Oracle Applications design-time automatically generates a wrapper stored procedure and loads it on the underlying database.

- Oracle Adapter for Oracle Applications provides flexfield support for PL/SQL APIs. Once the selected API is displayed in the Oracle Application Module Browser, you can either configure flexfield mappings for the API that has flexfields defined in Oracle E-Business Suite or use current data without further flexfield configuration.

### Displaying Selected API in the Oracle Applications Module Browser

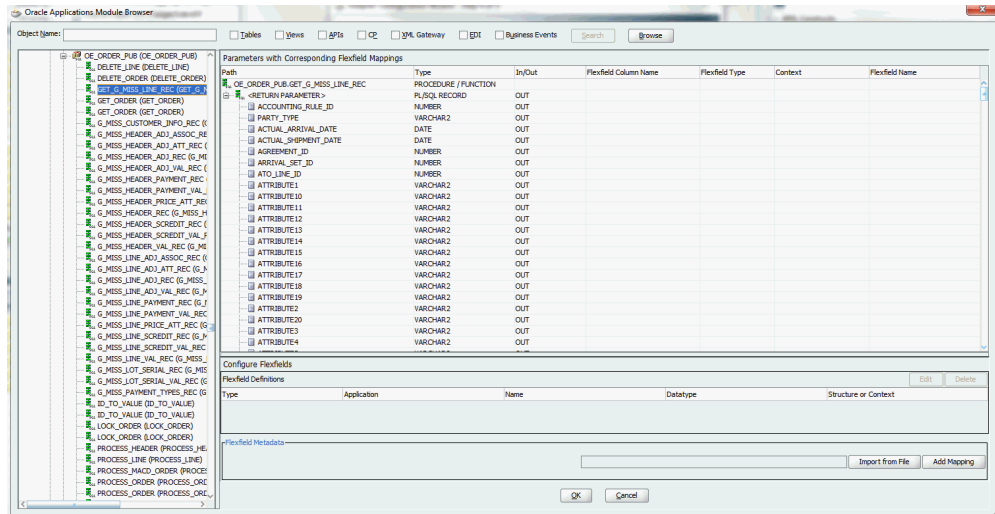

### Configuring Flexfield Data for the Selected API

Perform either one of the following tasks in the Oracle Application Module Browser:

- Use the current data without further configuration by clicking **OK** to continue.
- Configure flexfield data by either using an existing flexfield mapping or creating a new mapping through a flexfield wizard if desired.



- **Creating a New Mapping**

You can create a new mapping for a selected API by clicking **Add Mapping** in the Flexfield Metadata section. A new flexfield mapping wizard appears guiding you through each configuration page where you can add key and descriptive flexfields, as well as configure flexfield mapping between the selected API parameters and flexfields defined in the Oracle E-Business Suite instance.

See: Adding or Configuring a New Mapping, page 4-29.

- **Importing an Existing Mapping**

Instead of creating a new mapping, you can use an existing mapping that has been created earlier by clicking **Import from File** in the Flexfield Metadata section. This lets you select a desired flexfield mapping for your selected API. Once a desired mapping is imported, you can modify the context values for a descriptive flexfield, and modify structure for a key flexfield if needed to meet your needs.

See: Importing an Existing Flexfield Mapping, page 4-73.

For more information on flexfield support for PL/SQL APIs and how to modify existing configuration, see Flexfield Support for PL/SQL APIs, page 4-21.

In this example, click **OK** to continue.

Please note that the input and the output parameters of the Stored Procedure contains complex data types that are not readily mapped to JDBC types. The Adapter for Oracle Applications wizard provides a mechanism that detects when these types are used and then invokes Oracle JPublisher to generate the necessary wrappers automatically. Oracle JPublisher generates two SQL files, one to create schema objects, and another to drop them. The SQL that creates the schema objects is automatically executed from within the wizard to create the schema objects in the database schema before the XSD is generated.

The Adapter Service points to the wrapper Stored Procedure instead of the Process Order Line Stored Procedure. The Adapter design-time automatically loads the wrapper procedure onto the underlying database.

7. In the Application Interface page, click **Next**.

## Application Interface Page

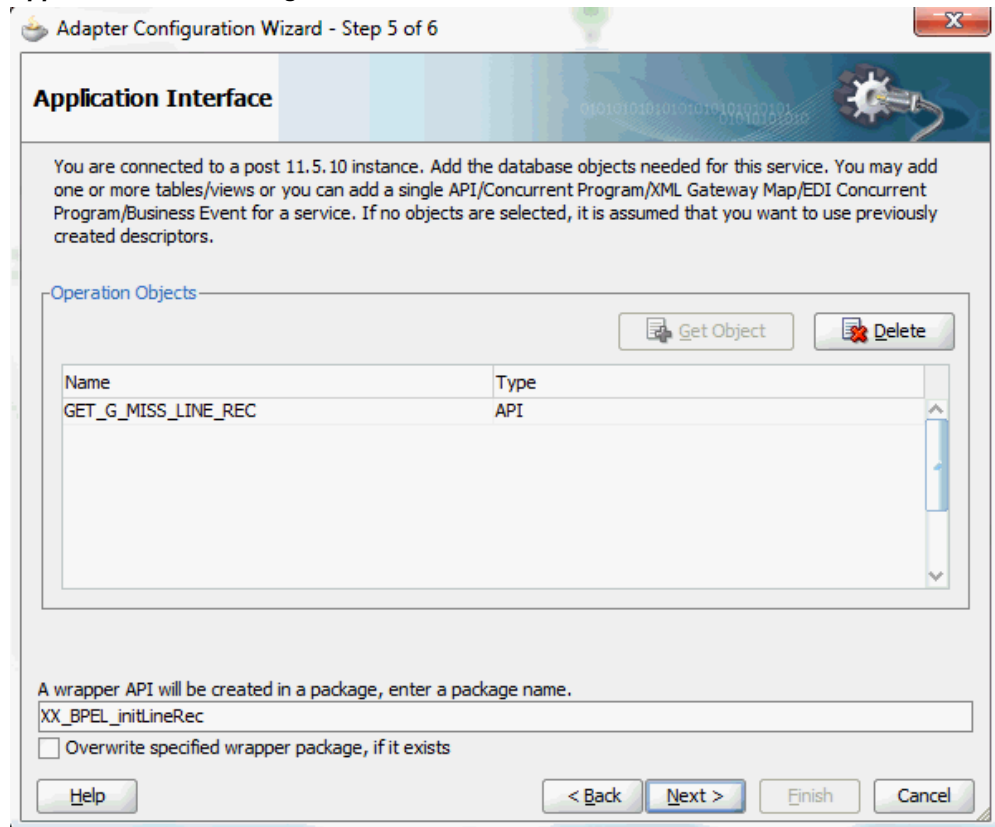

In the Finish page, click **Finish** to complete the process of configuring Adapter for Oracle Applications.

The wizard generates the WSDL file corresponding to the XML schema. This WSDL file is now available for the partner link.

8. Click **Apply** and then **OK**. The partner link is created with the required WSDL settings.

After adding and configuring the partner link, the next task is to configure the BPEL process.

### To add the second partner link:

1. Click **BPEL Services** in the Component Palette.  
Drag and drop **Oracle Applications** from the **BPEL Services** list into the right Partner Link swim lane of the process diagram. The Adapter Configuration Wizard Welcome page appears. Click **Next**.
2. Enter a service name in the **Service Name** field. For example, `OrderManagement`.

Click **Next**. The Service Connection dialog appears.

3. You can perform either one of the following options for your database connection:

**Note:** You need to connect to the database where Oracle Applications is running.

- You can create a new database connection by clicking **Create a New Database Connection** icon.

How to define a new database connection, see *Create a New Database Connection*, page 5-13.

- You can select an existing database connection that you have configured earlier from the **Connection** drop-down list.

The Service Connection page will be displayed with the selected connection information. The JNDI (Java Naming and Directory Interface) name corresponding to the database connection appears automatically in the **Database Server JNDI Name** field. Alternatively, you can specify a JNDI name.

**Note:** When you specify a JNDI name, the deployment descriptor of the Oracle Applications adapter must associate this JNDI name with configuration properties required by the adapter to access the database.

The JNDI name acts as a placeholder for the connection used when your service is deployed to the BPEL server. This enables you to use different databases for development and later for production.

**Note:** For more information about JNDI concepts, refer to *Oracle Fusion Middleware User's Guide for Technology Adapters*.

4. Once you have completed creating a new connection for the service, you can add a PL/SQL API by browsing through the list of APIs available in Oracle Applications.

Click **Next**.

**For Oracle E-Business Suite Release 12:**

If you are connecting to Oracle E-Business Suite Release 12, then the **IREP File not present** dialog appears indicating that Adapter could not find the Oracle Integration Repository data file corresponding to the database you are connecting in your workspace. Absence of the data file would make browsing or searching of Integration Repository tree considerably slow. You can choose to extract the data file and create a local copy of the Integration Repository data file. Once it is created successfully, Adapter will pick it up automatically next time and retrieve data from

your local Integration Repository.

You can select one of the following options:

- Click **Yes** to extract the Integration Repository data file.

### **Extracting Integration Repository Data File**

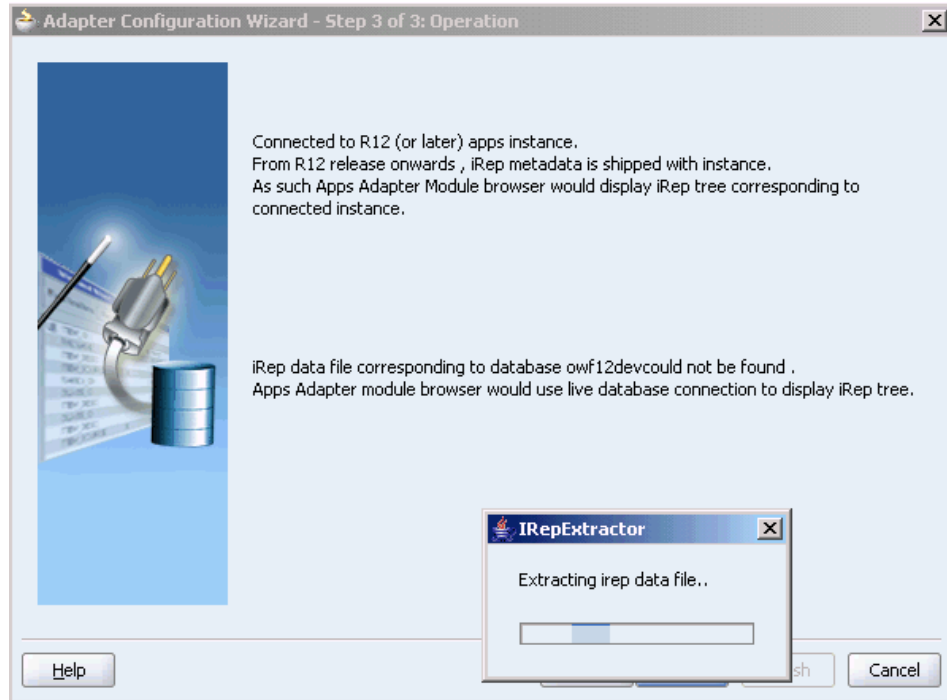

After the system successfully creates a local copy of the Integration Repository data file, next time when you connect to the database, you will find the **IRep Data File** field appears in the Operation dialog indicating where your local copy exists with the creation date and time as part of the file name.

### Using the Local Integration Repository Data File

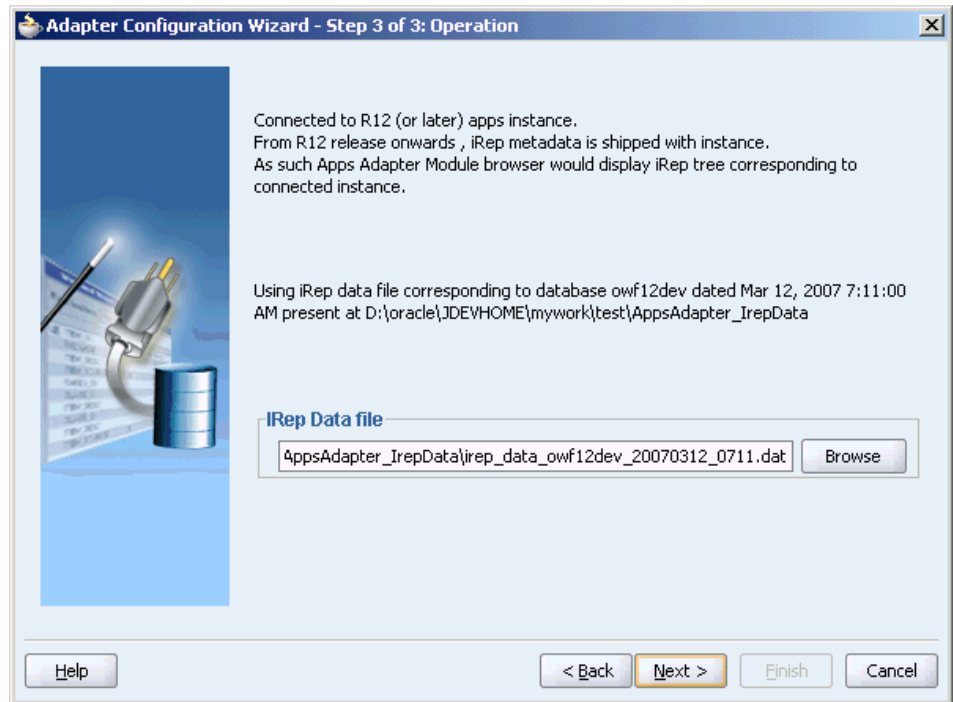

- Click **No** to query the Integration Repository data file from the live database you are connecting to display the Integration Repository tree.

Click **Next** in the Operation page to open the Oracle Applications Module Browser.

#### For Oracle E-Business Suite Release 11.5.9:

If you are connecting to an Oracle E-Business Suite Release 11.5.9 instance, you must select the interface type in the Adapter Configuration Wizard. Select **Tables/Views/APIs/Concurrent Programs** to proceed.

Click **Get Object** in the Application Interface dialog to open the Oracle Applications Module Browser.

5. The Oracle Applications Module Browser combines interface data from Oracle Integration Repository with information about the additional interfaces supported by Oracle Application Adapter, organized in a tree hierarchy.

Select the required PL/SQL API. For example, select *Process Order Line (PROCESS\_LINE)* API from *Product Families > Supply Chain Management (SCM\_PF) > Supply Chain Trading Connector (CLN) > Sales Order (ONT\_SALES\_ORDER) > PLSQL > Process Order API (OE\_ORDER\_PUB) > Process Order Line (PROCESS\_LINE)*.

**Note:** Use the Search option to quickly find the required objects. Enter the required database object name in the **Object Name** field and select **APIs**. And then, click **Search** to retrieve the required database objects. When searching for a PL/SQL API, enter the package name, and *not* the procedure name. In contrast, when using the DB Adapter Wizard, the user *must* enter the name of the PL/SQL API while searching.

- Oracle Adapter for Oracle Applications provides flexfield support for PL/SQL APIs. Once the selected API is displayed in the Oracle Application Module Browser, you can either configure flexfield mappings for the API that has flexfields defined in Oracle E-Business Suite or use current data without further flexfield configuration.

### Selected API Displayed in the Oracle Applications Module Browser

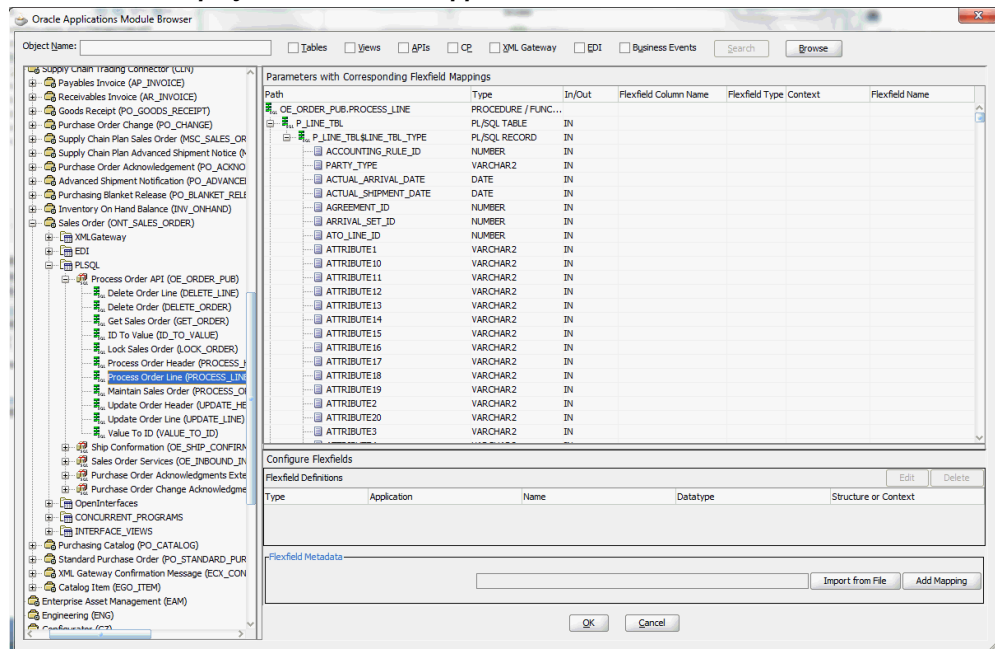

### Configuring Flexfield Data for the Selected API

Perform either one of the following tasks in the Oracle Application Module Browser:

- Use the current data without flexfield configuration by clicking **OK** to continue.
- Configure flexfield data by either using an existing flexfield mapping or creating a new mapping through a flexfield wizard if desired.
  - Creating a New Mapping**

You can create a new mapping for a selected API by clicking **Add Mapping** in the Flexfield Metadata section. A new flexfield mapping wizard appears guiding you through each configuration page where you can add key and descriptive flexfields, as well as configure flexfield mapping between the selected API parameters and flexfields defined in the Oracle E-Business Suite instance.

See: Adding or Configuring a New Mapping, page 4-29.

- **Importing an Existing Mapping**

Instead of creating a new mapping, you can use an existing mapping that has been created earlier by clicking **Import from File** in the Flexfield Metadata section. This lets you select a desired flexfield mapping for your selected API. Once a desired mapping is imported, you can modify the context values for a descriptive flexfield, and modify structure for a key flexfield if needed to meet your needs.

See: Importing an Existing Flexfield Mapping, page 4-73.

For more information on flexfield support for PL/SQL APIs and how to modify existing configuration, see *Flexfield Support for PL/SQL APIs*, page 4-21.

In this example, click **OK** to continue.

Please note that the input and the output parameters of the Stored Procedure contains complex data types that are not readily mapped to JDBC types. The Adapter for Oracle Applications wizard provides a mechanism that detects when these types are used and then invokes Oracle JPublisher to generate the necessary wrappers automatically. Oracle JPublisher generates two SQL files, one to create schema objects, and another to drop them. The SQL that creates the schema objects is automatically executed from within the wizard to create the schema objects in the database schema before the XSD is generated.

The Adapter Service points to the wrapper Stored Procedure instead of the Process Order Line Stored Procedure. The Adapter design-time automatically loads the wrapper procedure onto the underlying database.

7. In the Application Interface page, click **Next**.

## Adapter Configuration Wizard - Application Interface Page

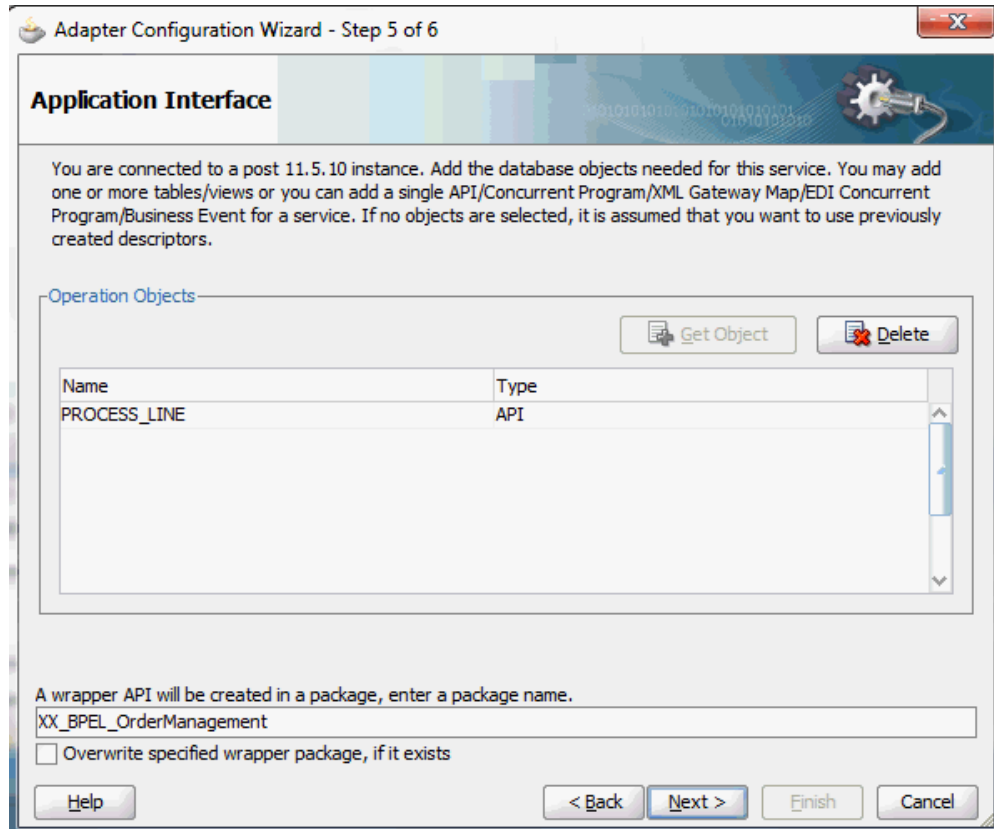

8. In the Finish page, click **Finish** to complete the process of configuring Adapter for Oracle Applications.

The wizard generates the WSDL file corresponding to the XML schema. This WSDL file is now available for the partner link.

9. Click **Apply** and then **OK**. The partner link is created with the required WSDL settings.

After adding and configuring the partner link, the next task is to configure the BPEL process.

## Adding a Partner Link for File Adapter

Use this step to configure a BPEL process by synchronously reading an existing purchase order to obtain the order details.

**To add a Partner Link for File Adapter to read order details:**

1. In JDeveloper BPEL Designer, click **BPEL Services** in the Component Palette.



Drag and drop **File Adapter** from the **BPEL Services** list into the right Partner Link swim lane of the process diagram. The Adapter Configuration Wizard Welcome page appears.

Click **Next**.

2. In the Service Name page, enter a name for the file adapter service, such as `getOrderDetails`.
3. Click **Next**. The Adapter Interface page appears.

### Specifying the Adapter Interface

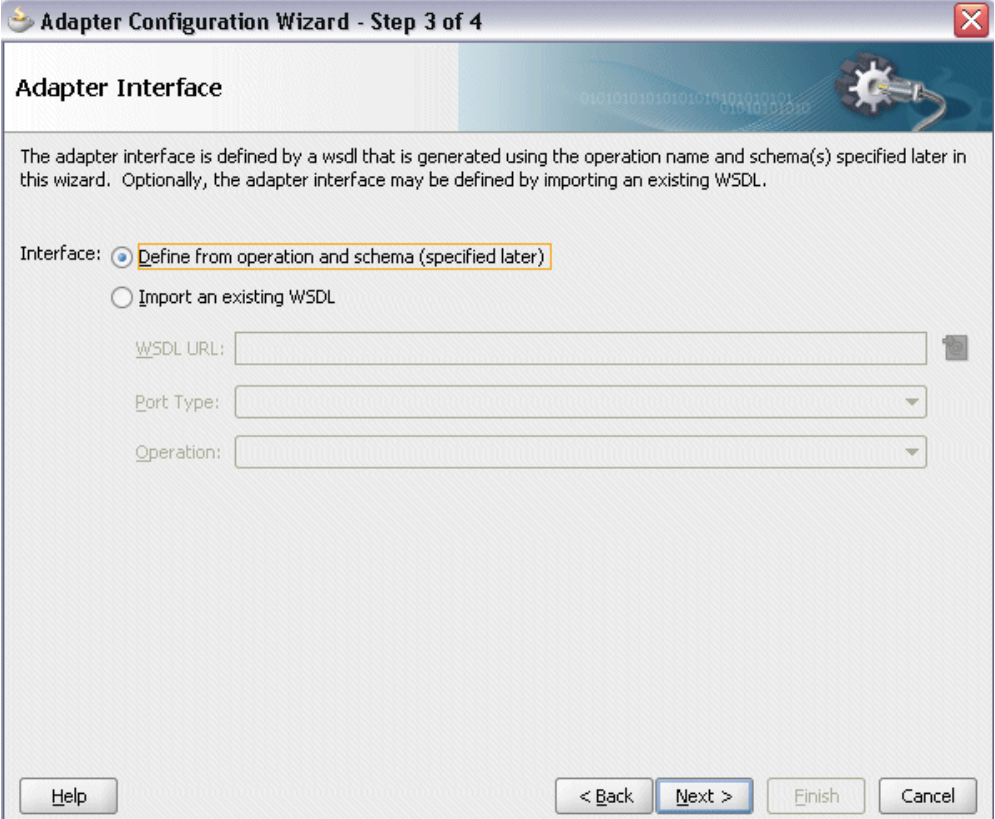

The screenshot shows the 'Adapter Configuration Wizard - Step 3 of 4' window. The title bar includes a close button (X). The main window has a header 'Adapter Interface' and a decorative background with a gear and binary code. Below the header, there is a text block: 'The adapter interface is defined by a wsdl that is generated using the operation name and schema(s) specified later in this wizard. Optionally, the adapter interface may be defined by importing an existing WSDL.' Underneath, there are two radio buttons: 'Define from operation and schema (specified later)' (which is selected) and 'Import an existing WSDL'. Below the radio buttons are three input fields: 'WSDL URL:' (with a file icon), 'Port Type:' (a dropdown menu), and 'Operation:' (a dropdown menu). At the bottom of the window, there are four buttons: 'Help', '< Back', 'Next >' (highlighted in blue), 'Finish', and 'Cancel'.

Select the **Define from operation and schema (specified later)** radio button and click **Next**.

4. In the Operation page, specify the operation type. For example, select the **Synchronous Read File** radio button. This automatically populates the **Operation Name** field.

### Specifying the Operation

The screenshot shows a window titled "Adapter Configuration Wizard - Step 4 of 8". The main heading is "Operation". Below the heading, there is a descriptive paragraph: "The File Adapter supports four operations. There is a Read File operation that polls for incoming files in your local file system, a Write File operation that creates outgoing files, a Synchronous Read File operation that reads the current contents of a file, and a List Files operation that lists file names in specified locations. Specify the Operation type and Operation Name. Only one operation per Adapter Service may be defined using this wizard." Below this text, there are four radio button options under the label "Operation Type": "Read File", "Write File", "Synchronous Read File" (which is selected), and "List Files". Below the radio buttons is a text input field labeled "Operation Name:" containing the text "SynchRead". At the bottom of the window, there are four buttons: "Help", "< Back", "Next >" (which is highlighted), "Finish", and "Cancel".

Click **Next** to access the File Directories page.

5. Select the **Logical Name** radio button and specify directory for incoming files, such as `inputDir`.

Ensure the **Delete files after successful retrieval** check box is not selected.

## Configuring the Input File

The screenshot shows a window titled "Adapter Configuration Wizard - Step 5 of 8" with a close button in the top right corner. The main heading is "File Directories". Below the heading, there is a sub-heading: "Enter directory information for the incoming file of the Synchronous Read File operation." The text "Directory names are specified as:" is followed by two radio buttons: "Physical Path" (unselected) and "Logical Name" (selected). Below this, there is a text input field labeled "Directory for Incoming Files (logical name):" containing the text "inputDir". There are two checkboxes: "Archive processed files" (unchecked) and "Delete files after successful retrieval" (unchecked). The "Archive processed files" checkbox is followed by the text "Archive Directory for Processed Files (logical name):" and an empty text input field. At the bottom of the window, there are four buttons: "Help", "< Back", "Next >" (highlighted in blue), "Finish", and "Cancel".

Click **Next** to open the File Name page.

6. Enter the name of the file for the synchronous read file operation. For example, enter `changeorder_data.xml`. Click **Next** to open the Messages page.
7. Select the 'browse for schema file' icon on the top right corner to open the Type Chooser window.

Click Type Explorer and select *Project WSDL Files > OrderManagement.wsdl > Inline Schemas > schema > InputParameters*.

**Note:** If the selected API is configured with flexfields, select the flexfield schema (`<servicename>_sp.xsd`) instead from the Type Chooser.

For example, *SynAccOrder* partner link service is created with descriptive flexfields. Select **Project Schema Files > SynAccOrder\_sp.xsd > SynAccOrder\_flex.xsd > InputParameters**.

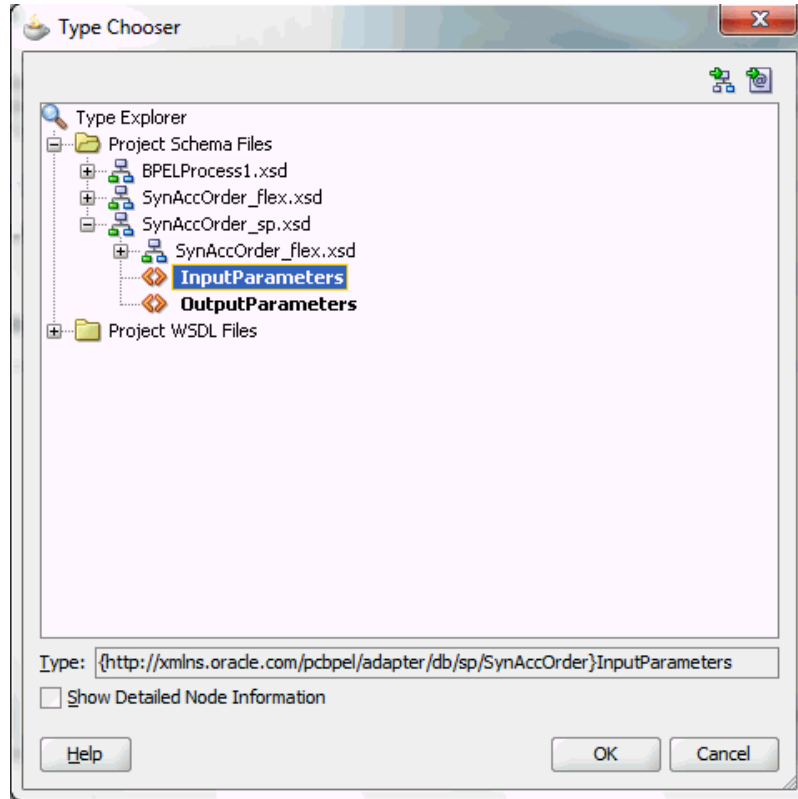

Click **OK**. The selected `SynAccOrder_sp.xsd` schema is displayed as URL and `InputParameters` is displayed as Schema Element.

For more information on flexfield support for PL/SQL APIs and how to modify existing configuration, see *Flexfield Support for PL/SQL APIs*, page 4-21.

The selected schema information will be automatically populated in the URL and Schema Element fields.

### Specifying Message Schema

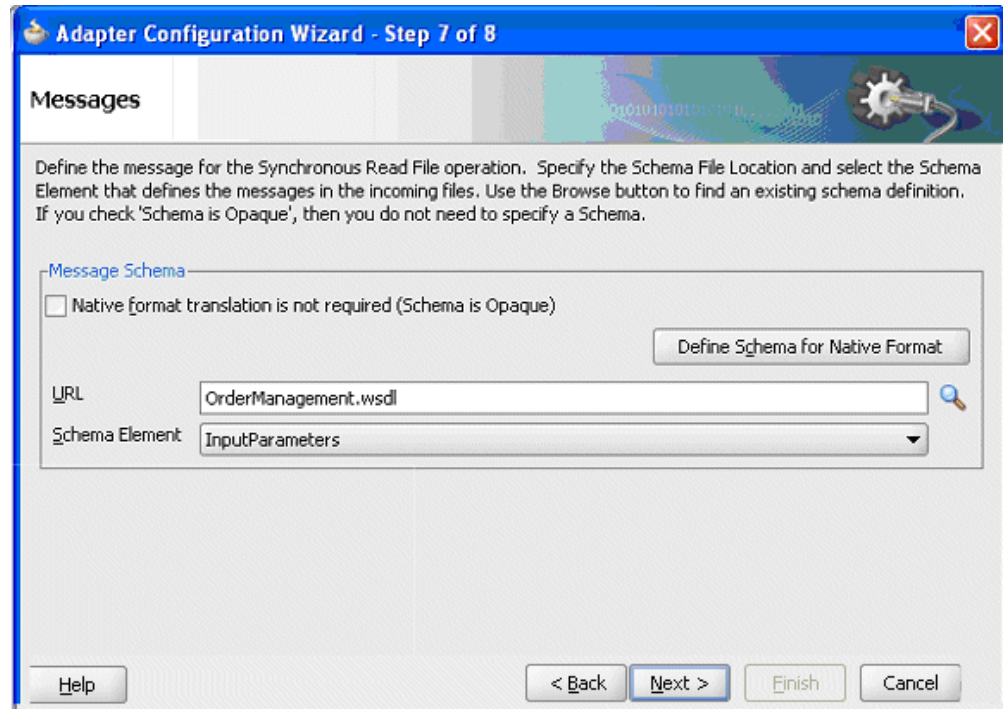

8. Click **Next** and then **Finish**. The wizard generates the WSDL file corresponding to the partner link. The main Create Partner Link dialog box appears, specifying the new WSDL file `getOrderDetails.wsdl`.

### Completing the Partner Link Configuration

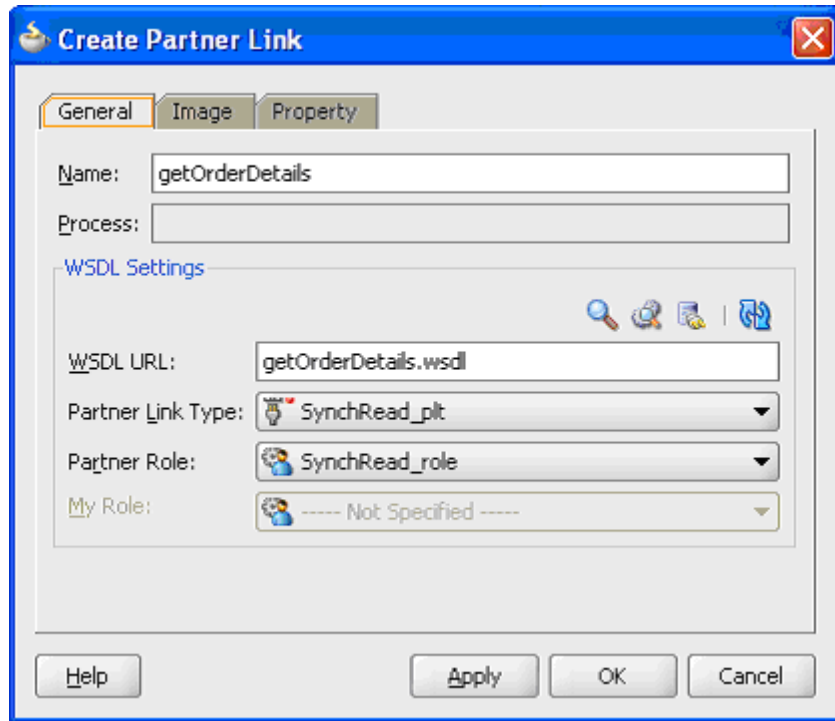

Click **Apply** and **OK** to complete the configuration and create the partner link with the required WSDL settings for the File Adapter service.

The `getOrderDetails` Partner Link appears in the BPEL process diagram.

## Defining Wrapper APIs

The Adapter Configuration wizard generates a wrapper API when a PL/SQL API has arguments of data types, such as PL/SQL Boolean, PL/SQL Table, or PL/SQL Record. For generating the wrapper API, Oracle JPublisher is automatically invoked in the background. When a wrapper API is created, besides the WSDL and XSD files, two SQL files are created: one for creating the wrapper API, and necessary datatypes and another for deleting it. The two SQL files are saved in the same directory where the WSDL and XSD files are stored, and are available in the Project view.

Following is a sample code of a PL/SQL API that would require a wrapper to be generated:

```
package pkg is
  type rec is record (...);
  type tbl is table of .. index by ..;
  procedure proc(r rec, t tbl, b boolean);
end;
```

If the preceding PL/SQL API is selected in the wizard, then a wrapper API will be

created, and loaded into the database. This wrapper API will be used instead of the originally selected PL/SQL API. For this reason, the content of the WSDL and XSD files represent the wrapper procedure, not the procedure originally selected.

The following are the types that will be created for the wrapper API:

- Object type for PL/SQL RECORD
- Nested table of the given type for PL/SQL TABLE. For example, the nested table of NUMBER.
- INTEGER substituted for PL/SQL BOOLEAN

The generated SQL file that creates the wrapper API also creates the required schema objects. The types of the wrapper API's parameters will be those of the new schema object types. The wrapper package will contain conversion APIs to convert between the base PL/SQL type and the new schema object types.

**Note:** The `SQLJUTL` package contains the `BOOL2INT` and `INT2BOOL` conversion functions used for PL/SQL BOOLEAN arguments whose data types have been changed to INTEGER.

The wrapper API is created in a package. This package is named `XX_BPEL_servicename`. *servicename* is the name of the service that you entered in Step 2 of Adding a Partner Link, page 9-9. If this package already exists, then the wizard prompts for a different package name, or to select a checkbox, to overwrite the existing package. Overwriting an existing package causes all PL/SQL APIs in the specified package to be lost. When the wizard creates a package for the wrapper, only one API, that is, the wrapper API, is contained in it.

**Note:** Despite specifying to overwrite an existing package, if the wrapper API already exists in the specified package, the wizard will not re-create the wrapper API, as it would take some time. This means no SQL files will be created, Oracle JPublisher will not be run, and the WSDL and XSD files will be for the existing wrapper API. The Finish page of the wizard will indicate that these actions will take place, but it is possible that they will not, depending on whether the wrapper already exists.

## Entering a Package Name for the Wrapper API

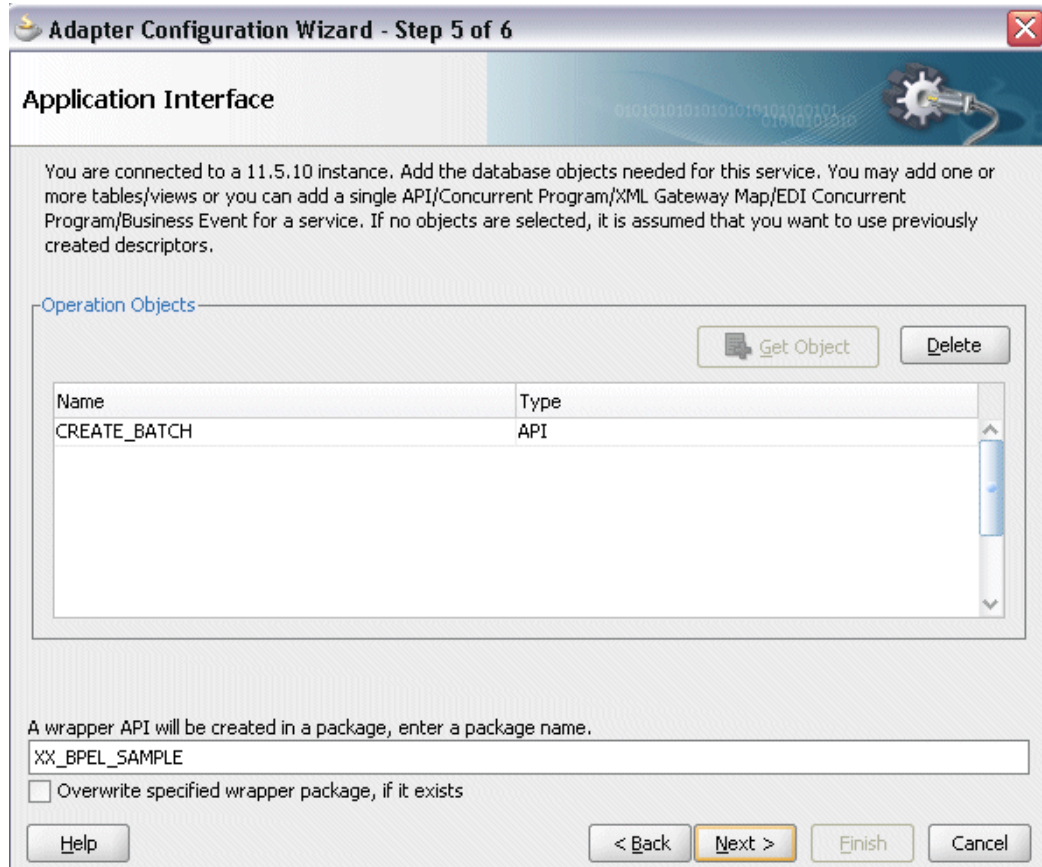

**Note:** The package name for the wrapper has a limit of 30 characters, and the wrapper API name has a limit of 29 characters. Thus, if the package name or the wrapper API name is longer than the maximum limit, it will be truncated accordingly.

The name of the wrapper API depends on whether the PL/SQL API that was originally selected is in a package or not. If the original PL/SQL API is a root-level API, that is, it does not belong in a package, then the name of the wrapper API will be, *TOPLEVEL\$original\_api\_name*. If the originally selected PL/SQL API is in a package, then the name of the wrapper API will be *original\_package\_name\$original\_api\_name*.

Wrapper APIs follow the naming convention of Oracle JPublisher. For example, if the original PL/SQL API was called `CREATE_EMPLOYEE` and was a root-level API, then the wrapper API would be named `TOPLEVEL$CREATE_EMPLOYEE`. If the original PL/SQL API is in a package called `EMPLOYEE`, then the wrapper API would be named `EMPLOYEE$CREATE_EMPLOYEE`.

The Finish page of the wizard is different when a wrapper API needs to be created. The Finish page informs you that a wrapper API is needed, and in addition, lists the name



of the wrapper package, wrapper API, and the SQL files that will be created.

**Note:** When a wrapper API needs to be created, it may take a while before the wizard completes. However, the processing time for subsequent PL/SQL APIs in the same package would be much shorter.

### The Finish Page

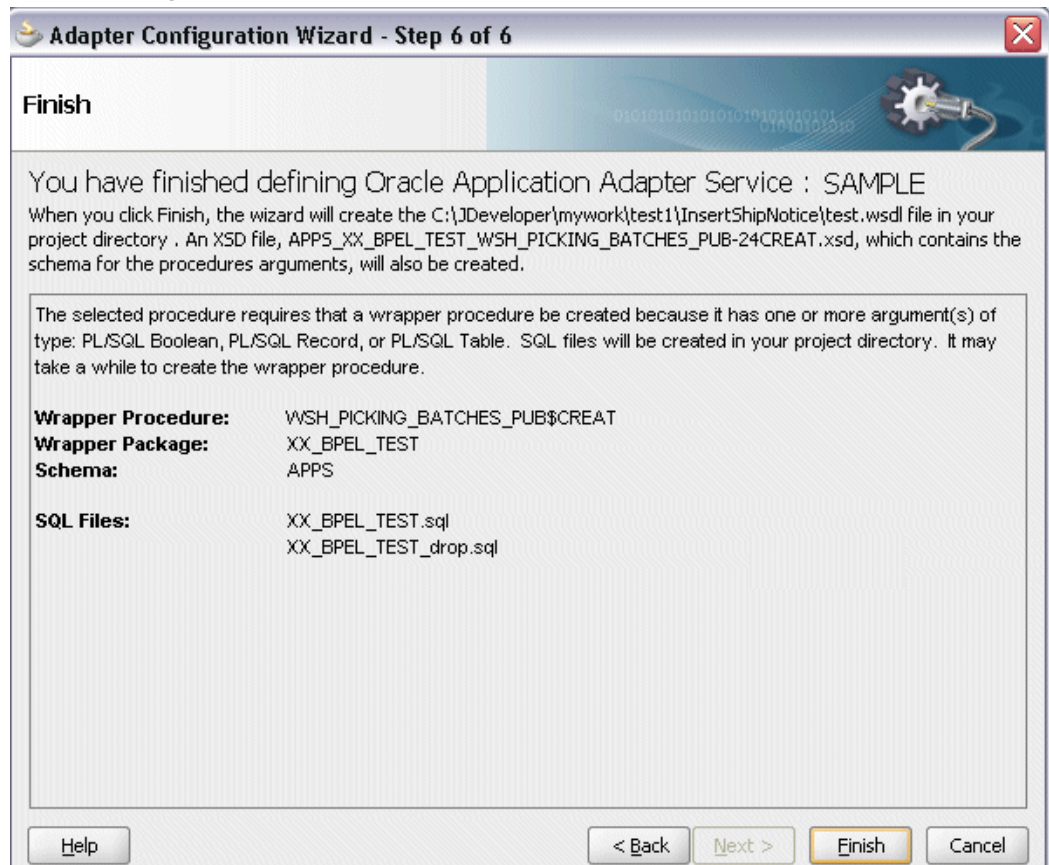

**Note:** The REF CURSOR type is not supported out of the box. However, for detailed steps to generate an adapter service for a PL/SQL API which takes REF CURSOR type, see the section "Support for REF CURSOR" in *Oracle BPEL Process Manager Developer's Guide* on OTN.

Overloaded APIs are not supported in release 11.5.10.

## Declaring Parameters with a DEFAULT Clause

You can declare parameters of a stored procedure with a DEFAULT clause, so that when you invoke the procedure without that parameter, BPEL Process Manager will

supply a default value for that parameter. For example:

```
PROCEDURE addEmployee (name VARCHAR2, country VARCHAR2 DEFAULT 'US')
```

This procedure can be invoked in the following two ways:

- `addEmployee ('John Smith') // country => 'US'`
- `addEmployee ('John Smith', 'France') // country => 'France'`

### Omitting Parameters With a DEFAULT Clause

You can omit elements for parameters with default values in the instance XML. The procedure will be invoked without these parameters, allowing their default values to be used, as shown in the following example of input and runtime invocation.

#### Input

```
<db:InputParameters xmlns:db="...">  
  <name>John Smith</name>  
</db:InputParameters>
```

#### Runtime Invocation

```
BEGIN addEmployee (name=>?); END; // country => 'US'
```

If the input includes a value for the defaulted parameter, the value in the input will be used, rather than the default, as follows:

#### Input

```
<db:InputParameters xmlns:db="...">  
  <name>John Smith</name>  
  <country>France</country>  
</db:InputParameters>
```

#### Runtime Invocation

```
BEGIN addEmployee (name=>?, country=>?); END; // country => 'France'
```

### Omitting Parameters Without a DEFAULT Clause

The element in the XSD for parameters with a default clause is annotated with a special tag to indicate that the parameter has a default clause, as shown in the following example.

```
<element name="country" ... db:default="true" .../>
```

This new functionality allows elements for parameters without a default clause also to be omitted in the instance XML. In these cases, the parameter is still included in the invocation of the stored procedure. A value of NULL is bound by default. Following is an example of a declaration where neither parameter has a DEFAULT clause:

```
PROCEDURE addEmployee (name VARCHAR2, country VARCHAR2)
```

In BPEL Process Manager release 10.1.2, elements for both parameters were required in the instance XML. If an element was omitted, it was presumed to have a DEFAULT clause, so the parameter was not included in the invocation of the procedure. In this case, the missing parameter resulted in a PL/SQL error stating that an incorrect number of arguments was passed to the procedure.

In the current BPEL Process Manager release, the missing parameter will be included in the invocation of the procedure. A NULL value will be bound, as shown in the following example:

### Input

```
<db:InputParameters xmlns:db="...">
  <name>John Smith</name>
</db:InputParameters>
```

### Runtime Invocation

```
BEGIN addEmployee (name =>?, country=>?); END; // country => NULL
```

Even though the element for *country* was not provided in the instance XML, it still appears in the call to the procedure. In this case, *country* will be NULL.

### DEFAULT Clause Handling in Wrapper Procedures:

If a procedure contains a special type requiring a wrapper to be generated, the default clauses on any of the original parameters will *not* be carried over to the wrapper, as shown in the following example:

```
PROCEDURE needsWrapper(isTrue BOOLEAN, value NUMBER DEFAULT 0)
```

Assuming that the procedure in the preceding example was defined at the top level, outside of a package, the generated wrapper will appear, as shown in the following example:

```
TOPLEVEL$NEEDSWRAPPER (isTrue INTEGER, value NUMBER)
```

In the preceding example, the `BOOLEAN` type has been replaced by `INTEGER`. The default clause on the value parameter is missing. In the current release, parameters of generated wrapper procedures will never have a default clause, even if these parameters did in the original procedure. If the element is missing in the instance XML, instead of defaulting to 0, then the value of the parameter will be NULL, as shown in the following example:

### Input

```
<db:InputParameters xmlns:db="...">
  <isTrue>1</isTrue>
</db:InputParameters>
```

### Runtime Invocation

```
BEGIN TOPLEVEL$NEEDSWRAPPER (isTrue =>?, value =>?); END; // value =>
NULL
```

To fix this, you can edit the generated SQL file, restoring the default clauses. You should then, run the SQL file to reload the wrapper definitions into the database schema. In addition, you should modify the generated XSD.

Following are the steps to fix the default clause with the wrapper generated for `needsWrapper()`:

1. Change the signature in the following manner in the generated wrapper SQL file, *from:*

```
TOPLEVEL$NEEDSWRAPPER (isTrue INTEGER, value NUMBER)
```

*To:*

```
TOPLEVEL$NEEDSWRAPPER (isTrue INTEGER, value NUMBER DEFAULT 0)
```

2. Reload the modified wrapper SQL file mentioned in the preceding example into the

appropriate database schema. For BOOLEAN parameters with DEFAULT clause, you need to map as follows:

```
DEFAULT TRUE (base) to DEFAULT 1 (wrapper)
DEFAULT FALSE (base) to DEFAULT 0 (wrapper)
```

For example, if the base stored procedure is `PROCEDURE needsWrapper (isTrue BOOLEAN TRUE, value NUMBER DEFAULT 0)`, then the generated wrapper would be `TOPLEVEL$NEEDSWRAPPER (isTrue INTEGER, value NUMBER)`. You should manually fix the store procedure to be `TOPLEVEL$NEEDSWRAPPER (isTrue INTEGER DEFAULT 1, value NUMBER DEFAULT 0)`

3. If a parameter has a default clause, then its corresponding element in the XSD must have an extra attribute, `db:default="true"`. For example, if a parameter has a default clause `TOPLEVEL$NEEDSWRAPPER (isTrue INTEGER DEFAULT 1, value NUMBER DEFAULT 0)`, then the elements in the XSD for `isTrue` and `value` need to have the following new attributes:

```
<element name="ISTRUE" ... db:default="true" .../>
<element name="VALUE" ... db:default="true" .../>
```

## Configuring the Invoke Activities

This step is to configure three Invoke activities:

1. To get the order details that is received from the Receive activity by invoking the `getOrderDetails` partner link in an XML file.
2. To initialize the existing purchase order by invoking `initLineRec` partner link.
3. To update the purchase order quantity information to Oracle Applications by invoking `OrderManagement` partner link.

### To add the first Invoke activity for a partner link to get order details:

1. In Oracle JDeveloper BPEL Designer, expand the **BPEL Constructs** from the Component Palette. Drag and drop the first **Invoke** activity into the center swim lane of the process diagram, between the **receiveInput** and **callbackClient** activities.
2. Link the Invoke activity to the `getOrderDetails` service. The Edit Invoke dialog appears.
3. Enter a name for the Invoke activity, then click the **Create** icon next to the **Input Variable** field to create a new variable. The Create Variable dialog box appears.
4. Select **Global Variable**, then enter a name for the variable. You can also accept the default name. Click **OK**.
5. In the Edit Invoke dialog, click the **Create** icon next to the **Output Variable** field to

create a new variable. The Create Variable dialog box appears.

Select **Global Variable**, then enter a name for the variable. You can also accept the default name. Click **OK**.

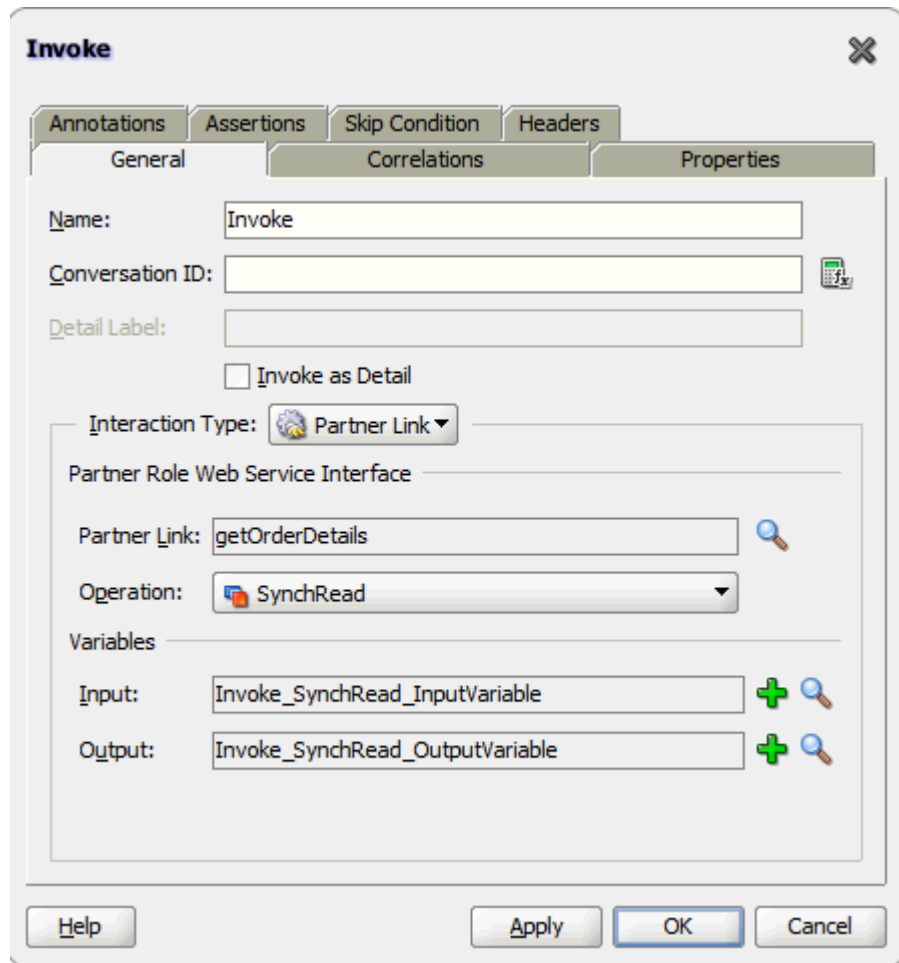

Click **Apply** and then **OK** in the Edit Invoke dialog to finish configuring the Invoke activity.

The Invoke activity appears in the process diagram.

**To add the second Invoke activity for a partner link to initialize the existing purchase order:**

1. In Oracle JDeveloper BPEL Designer, expand the **BPEL Constructs** from the Component Palette. Drag and drop the second **Invoke** activity into the center swim lane of the process diagram, between the first **Invoke** and **callbackClient** activities.
2. Link the Invoke activity to the `initLineRec` service. The Edit Invoke dialog box appears.

- Repeat Step 3 to Step 5 described in the first Invoke activity procedure to complete the second Invoke activity.

**Invoke**

Annotations Assertions Skip Condition Headers

General Correlations Properties

Name: Invoke

Conversation ID:

Detail Label:

Invoke as Detail

Interaction Type: Partner Link

Partner Role Web Service Interface

Partner Link: initLineRec

Operation: initLineRec

Variables

Input: Invoke\_initLineRec\_InputVariable

Output: Invoke\_initLineRec\_OutputVariable

Help Apply OK Cancel

**To add the third Invoke activity for a partner link to update the order quantity information to Oracle Applications:**

- In Oracle JDeveloper BPEL Designer, expand the **BPEL Constructs** from the Component Palette. Drag and drop the third **Invoke** activity into the center swim lane of the process diagram, between the second **Invoke** and **callbackClient** activities.
- Link the Invoke activity to the `OrderManagement` service. The Edit Invoke dialog box appears.
- Repeat Step 3 to Step 5 described in the first Invoke activity procedure.

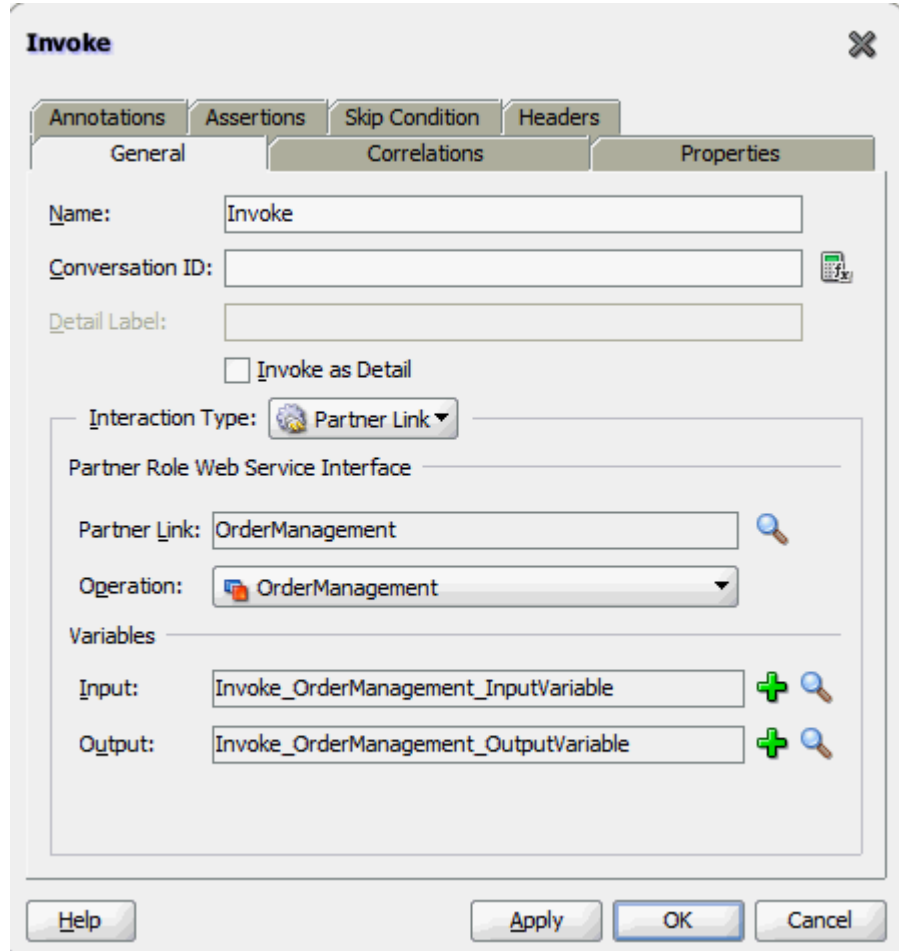

#### 4. Setting Header Properties for Applications Context

Use the following steps to set the header message properties required to pass applications context required to complete the BPEL process:

1. Select the Properties tab in the Edit Invoke dialog box.
2. Scroll down to locate the `jca.apps.Username` property from the list and double click the associated value field to enable the **Adapter Property Value** icon.

Click the icon to open the Adapter Property Value dialog for the selected `jca.apps.Username` property.

### Setting Header Message Properties

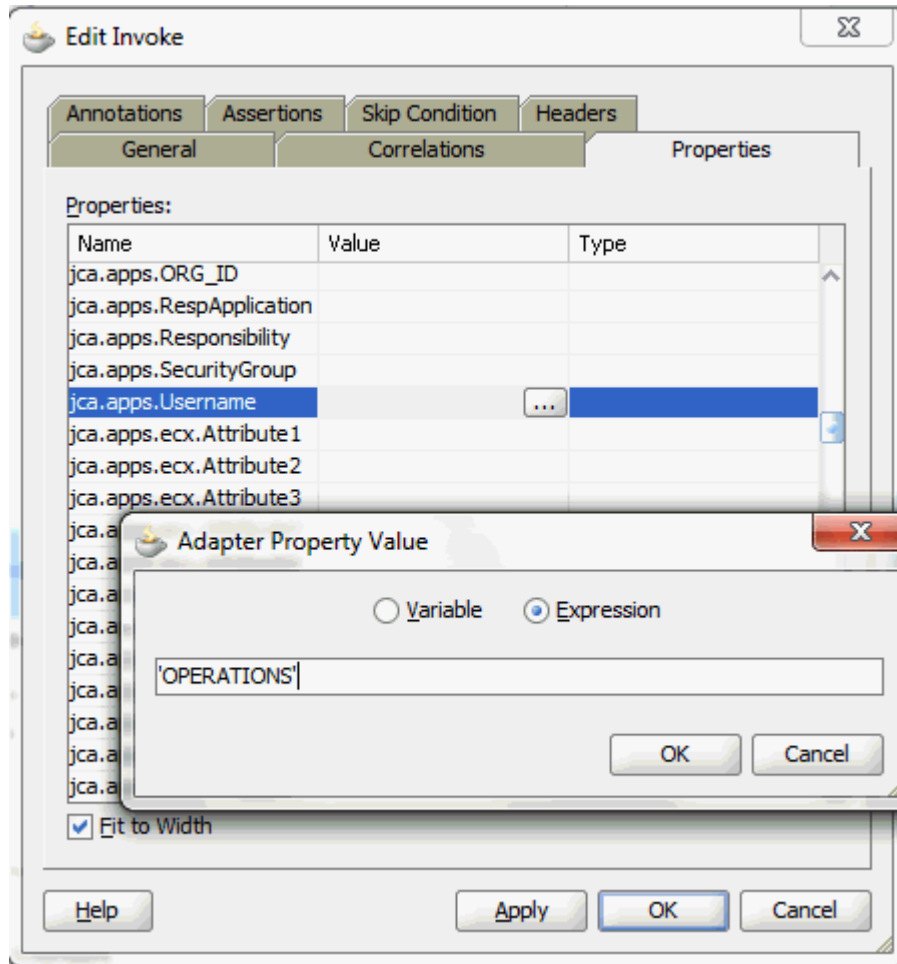

3. Select the **Expression** radio button and enter 'OPERATIONS' as the property value.  
Click **OK**.
4. Repeat Step 2 to Step 4 to assign 'Order Management Super User, Vision Operations (USA)' for jca.apps.Responsibility.
5. Click **Apply** and then **OK** to complete the Invoke activity.

## Configuring a Transform Activity

The Transform activity can be used to configure the parameters for the input and output variables. The Transform activity can also be used if variable values need to be transformed before updating them in Oracle Applications.



### To configure a Transform activity:

Before add a Transform activity, use the following steps to add variables:

1. From the **structure** panel, select `ChangeOrderAPI.bpel` > **Variables** > **Process** > **Variables** folder. Right click on **Variables** folder and select **Create Variable** from the drop-down menu.
2. In the Create Variable dialog, enter `temp_miss_line` in the variable Name field.
3. Select the **Message Type** radio button and click the **Browse Message Type** icon to open the Type Chooser.

Select `args_in_msg` from *Message Types* > *Project WSDL Files* > *OrderManagement.wsdl* > *Message Types*. Click OK to close the Type Chooser.

The selected information will be populated in the Message Type field in the Create Variable dialog.

Use the following step to configure the Transform activity:

1. In Oracle JDeveloper BPEL Designer, expand the **Oracle Extensions** from the Component Palette. Drag and drop **Transform** into center swim lane of the process map window. The **Transform** activity should be placed in between the second and third **Invoke** activities.

This Transform activity is used to set the output of `initLineRec` service to the input of the `OrderManagement` service.

2. Double-click **Transform** in the process map to open the Transform dialog. The Transformation tab is selected by default.

Click the General tab to name this Transform activity as `set_Miss_Line`.

3. In the Transformation tab, click the **Create** icon to open the Source Variable dialog.

**Source Variable Dialog**

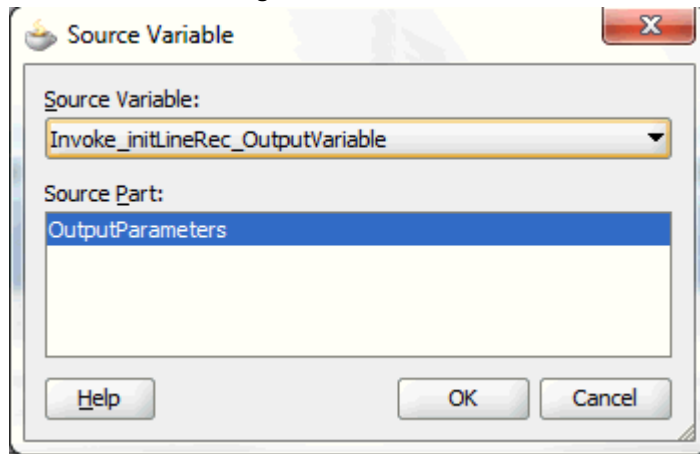

Select the `Invoke_initLineRec_OutputVariable` from the Source Variable drop-down list, and select `OutputParameters` element as the Source Part value. Click **OK**.

4. Select the `Invoke_OrderManagement_InputVariable` from the Target Variable drop-down list. The Target Part value of the variable is also selected.

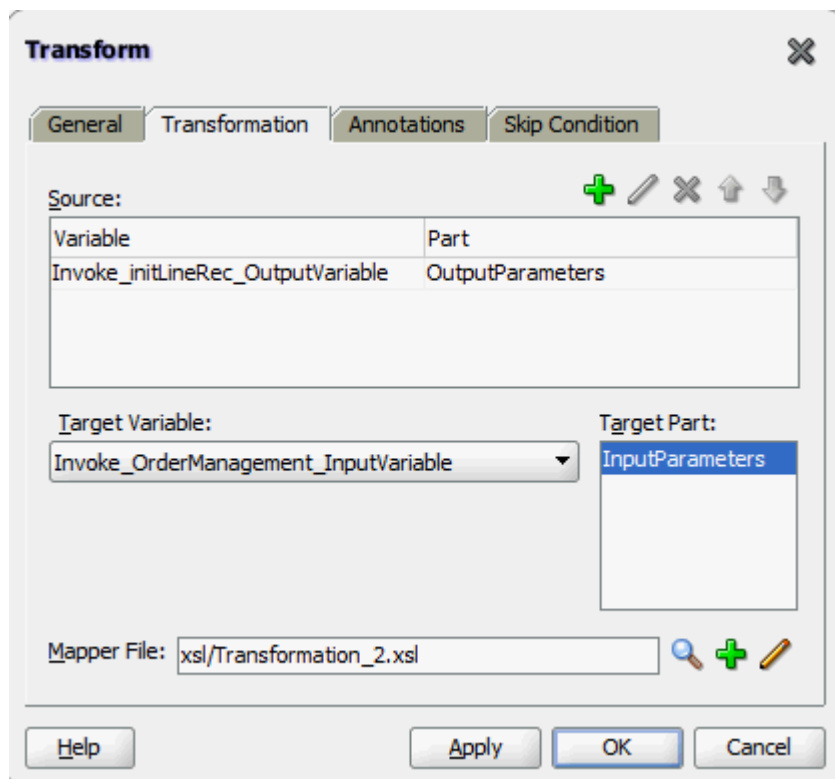

5. Click the **Create** icon next to the Mapper File field to create a new transformation mapping file. Mapper File specifies the file in which you create the mappings using the XSLT Mapper Transformation tool.
6. The transformation mapping file appears. The **Design** view appears by default.
7. You can define the parameter values in the **Design** view. Drag a string function to the Design area. Connect the function to the appropriate parameter for which you want to define a value.

For example, link `db:OE_ORDER_PUB-24GET_G_MISS_LINE` from the source variable to `db:P_LINE_TBL_ITEM` as the target variable.

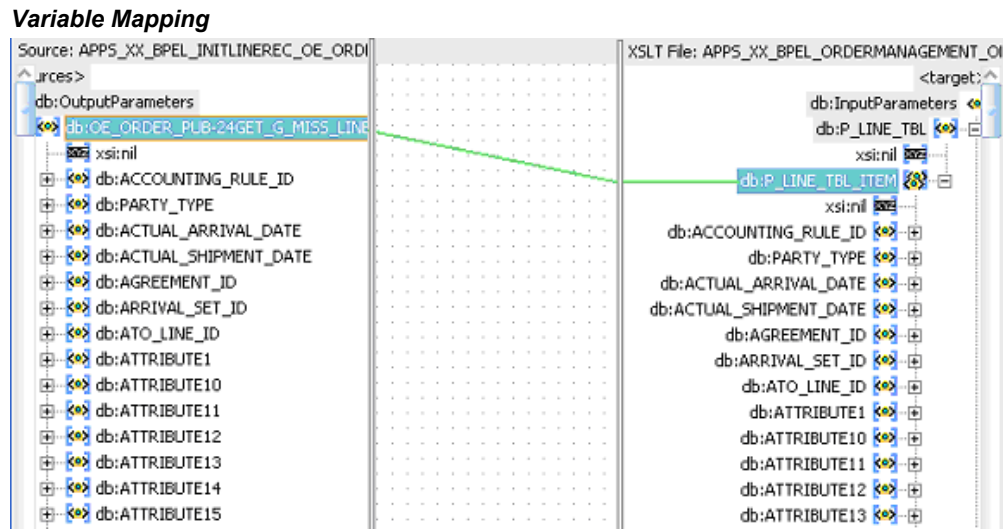

**Note:** You can use an input parameter value from the source variable, transform it using a string function, and use it as the input parameter value for the target variable.

8. Click **OK** to create the mapping from source variable to target variable.

## Configuring an Assign Activity

Use the Assign activity to pass the output of `getOrderDetails` service and `initLineRec` service as an input to the `OrderManagement` service.

**To add an Assign activity:**

1. In Oracle JDeveloper BPEL Designer, expand the **BPEL Constructs** from the Component Palette. Drag and drop the **Assign** activity into the center swim lane of the process diagram right after the **Transform** activity that you just created earlier.

2. Double-click the **Assign** activity to access the Edit Assign dialog.  
Click the General tab to enter a name for the Assign activity. For example, setOrderChanges.
3. Select the Copy Rules tab and expand the target trees:
  - In the From navigation tree, navigate to **Variable > Process > Variables > Temp\_miss\_line > Input Parameters** and select **ns4:P\_LINE\_TBL**.
  - In the To navigation tree, navigate to **Variable > Process > Variables > Invoke\_OrderManagement\_InputVariable > Input Parameters** and select **ns4:P\_LINE\_TBL**.
  - Click **OK**. The Edit Assign dialog box appears.

Drag the source node (ns4:P\_LINE\_TBL) to connect to the target node (ns4:P\_LINE\_TBL) that you just specified. This creates a line that connects the source and target nodes. The copy rule is displayed in the From and To sections at the bottom of the Edit Assign dialog box.

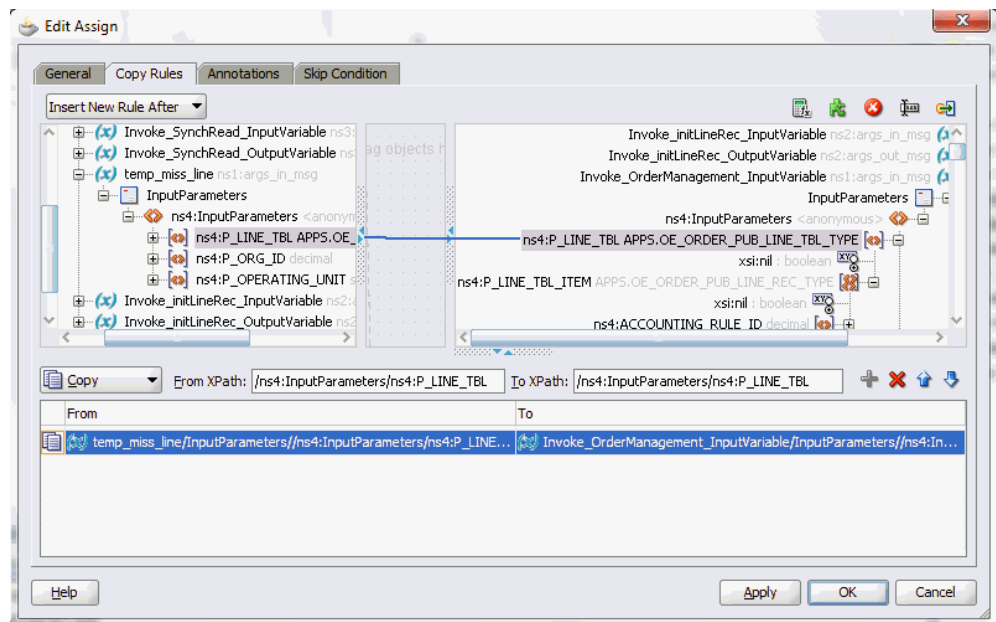

4. Enter the second pair of parameters:
  - Click the Expression icon to invoke the Expression Builder dialog.

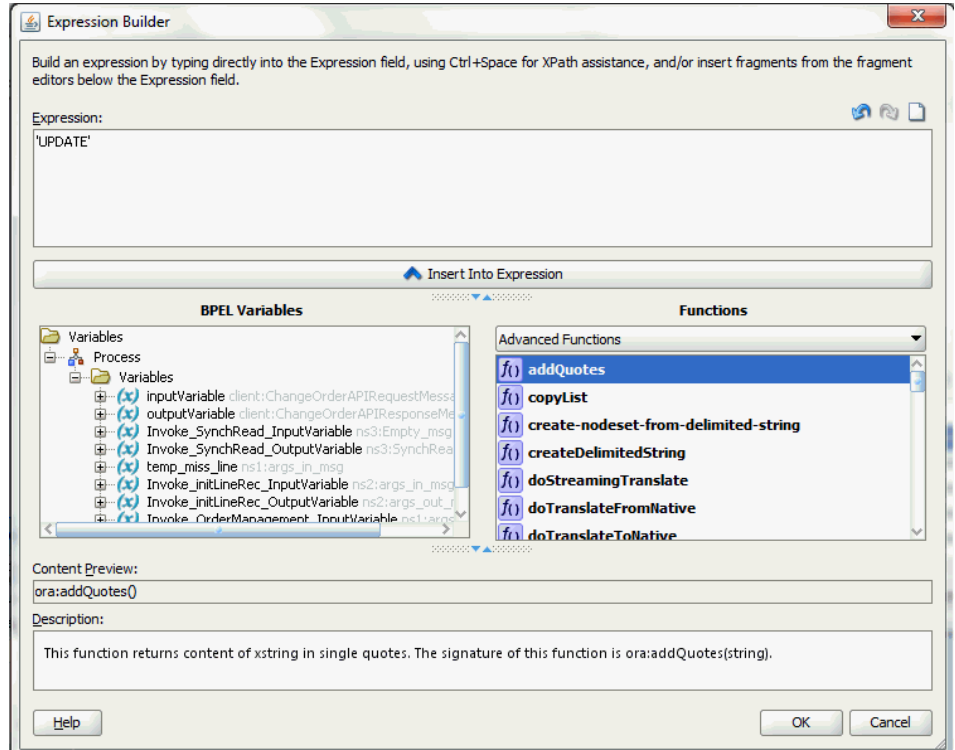

Enter 'UPDATE' in the Expression box. Click **OK**. The Expression icon with the expression value ('UPDATE') appears in the center of the Edit Assign dialog, between the From and To navigation tree nodes.

- In the To navigation tree, navigate to **Variable > Process > Variables > Invoke\_OrderManagement\_InputVariable > Input Parameters > P\_LINE\_TBL > P\_LINE\_TBL\_ITEM** and select **ns4:OPERATION**.

Drag the Expression icon to connect to the target node (ns4:OPERATION) that you just identified. This creates a line that connects the source and target nodes. The copy rule is displayed in the From and To sections at the bottom of the Edit Assign dialog box.

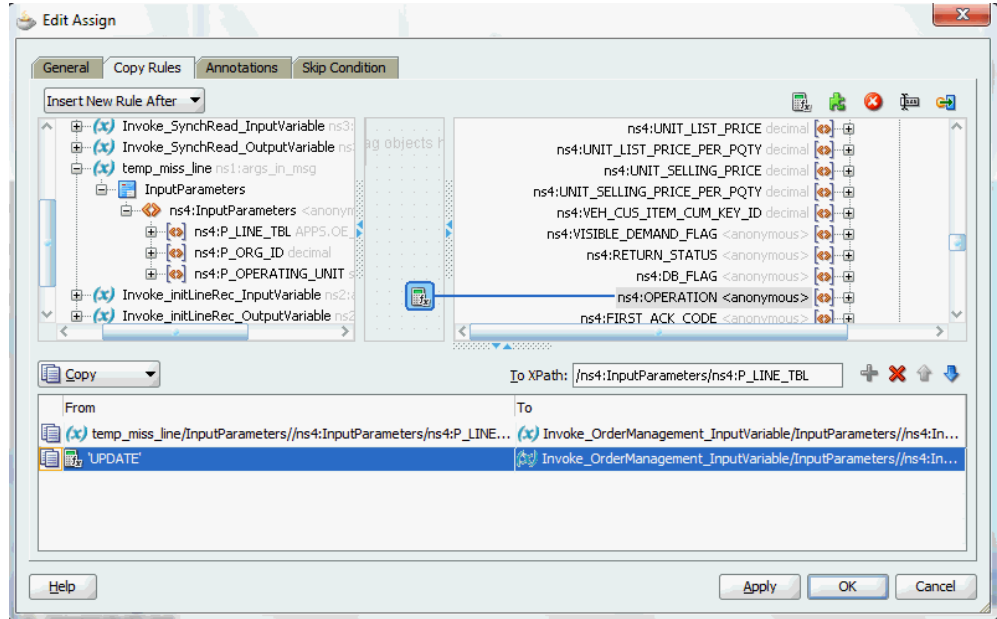

5. Enter the third pair of parameters:
  - Click the Expression icon to invoke the Expression Builder dialog. Enter 'Update Order Quantity' in the Expression box. Click OK. The Expression icon with the expression value ('Update Order Quantity') appears in the center of the Edit Assign dialog, between the From and To navigation tree nodes.
  - In the To navigation tree, navigate to **Variable > Process > Variables > Invoke\_OrderManagement\_InputVariable > P\_LINE\_TBL > P\_LINE\_TBL\_ITEM** and select **ns4:CHANGE\_REASON**.

Drag the Expression icon to connect to the target node (ns4:CHANGE\_REASON) that you just identified. This creates a line that connects the source and target nodes. The copy rule is displayed in the From and To sections at the bottom of the Edit Assign dialog box.

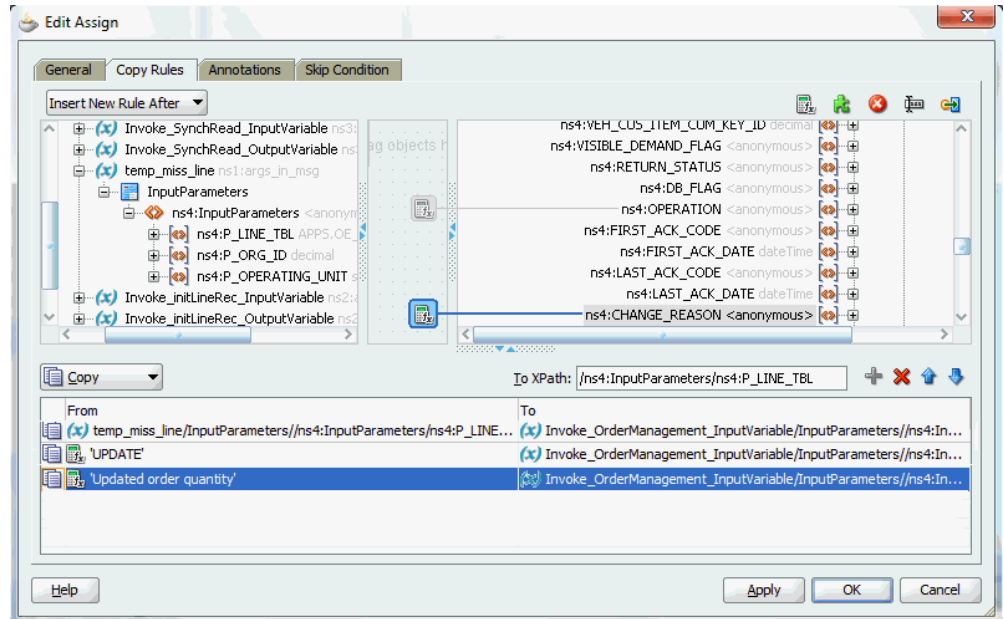

6. Enter the fourth pair of parameters:

- In the From navigation tree, navigate to **Variable > Process > Variables > Invoke\_SynchRead\_OutputVariable>Input Parameters > P\_LINE\_TBL >P\_LINE\_TBL\_ITEM** and select **ns4:LINE\_ID**.
- In the To navigation tree, navigate to **Variable > Process > Variables > Invoke\_OrderManagement\_InputVariable > P\_LINE\_TBL > P\_LINE\_TBL\_ITEM** and select **ns4:LINE\_ID**.

Drag the source node (ns4:LINE\_ID) to connect to the target node (ns4:LINE\_ID) that you just specified. This creates a line that connects the source and target nodes. The copy rule is displayed in the From and To sections at the bottom of the Edit Assign dialog box.

7. Enter the fifth pair of parameters:

- In the From navigation tree, navigate to **Variable > Process > Variables > Invoke\_SynchRead\_OutputVariable>Input Parameters > P\_LINE\_TBL >P\_LINE\_TBL\_ITEM** and select **ns4:ORDERED\_QUANTITY**.
- In the To navigation tree, navigate to **Variable > Process > Variables > Invoke\_OrderManagement\_InputVariable > P\_LINE\_TBL > P\_LINE\_TBL\_ITEM** and select **ns4:ORDERED\_QUANTITY**.

Drag the source node (ns4:ORDERED\_QUANTITY) to connect to the target node (ns4:ORDERED\_QUANTITY) that you just specified. This creates a line that connects the source and target nodes. The copy rule is displayed in the From and To

sections at the bottom of the Edit Assign dialog box.

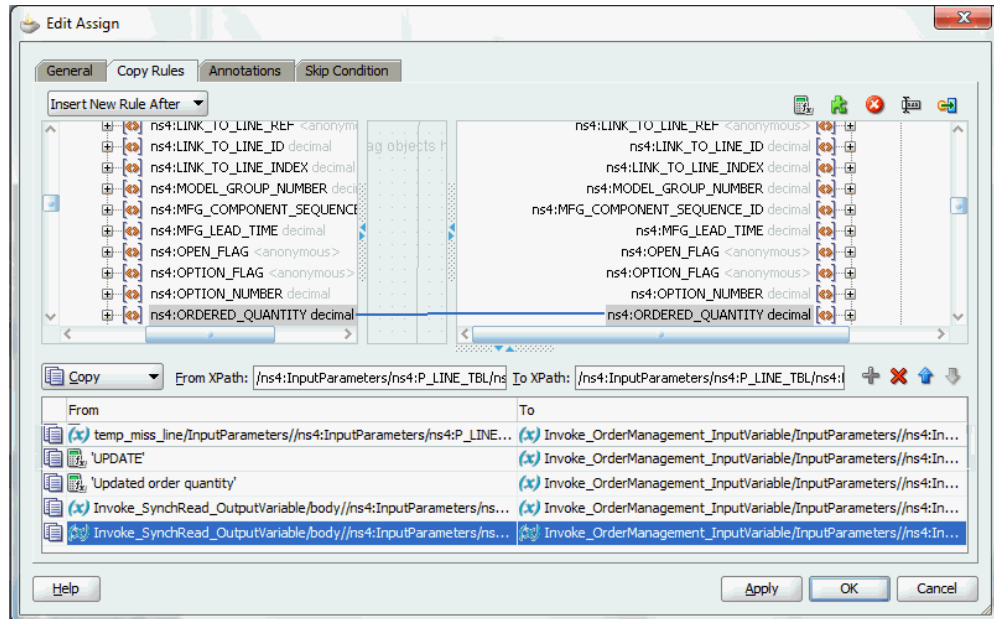

8. Click **Apply** and then **OK** to complete the configuration of the Assign activity.

## Run-Time Tasks for PL/SQL APIs

After designing the SOA Composite application with BPEL process, the next step is to deploy, run and monitor it.

1. Deploy the SOA Composite application with BPEL process, page 9-44
2. Test the deployed SOA Composite application with BPEL process, page 9-49

## Deploying the SOA Composite Application with BPEL Process

To invoke the services from the BPEL client contained in the SOA composite, the SOA composite needs to be deployed to the Oracle WebLogic managed server. This can be achieved using Oracle JDeveloper. Once the composite is deployed, it can be tested from the Oracle Enterprise Manager Fusion Middleware Control Console.

### Prerequisites

Before deploying the SOA composite with BPEL process using Oracle JDeveloper, you must have established the connectivity between the design-time environment and the run-time server. For more information, see *Configuring the Data Source in Oracle WebLogic Server*, page A-3 and *Creating an Application Server Connection*, page A-12.



**Note:** If a local instance of the WebLogic Server is used, start the WebLogic Server by selecting **Run > Start Server Instance** from Oracle JDeveloper. Once the WebLogic Admin Server "DefaultServer" instance is successfully started, the <Server started in Running mode> and DefaultServer started message in the Running:DefaultServer and Messages logs should appear.

**To deploy the SOA Composite application with BPEL process:**

1. Select the SOA Composite project in the Applications window.
2. Right-click the project name, and then select **Deploy > [project name] > [serverConnection]** from the menu that appears.

For example, you can select **Deploy > ChangeOrderAPI> soa-server1** to deploy the process if you have the connection set up appropriately.

## Deploying the SOA Composite application

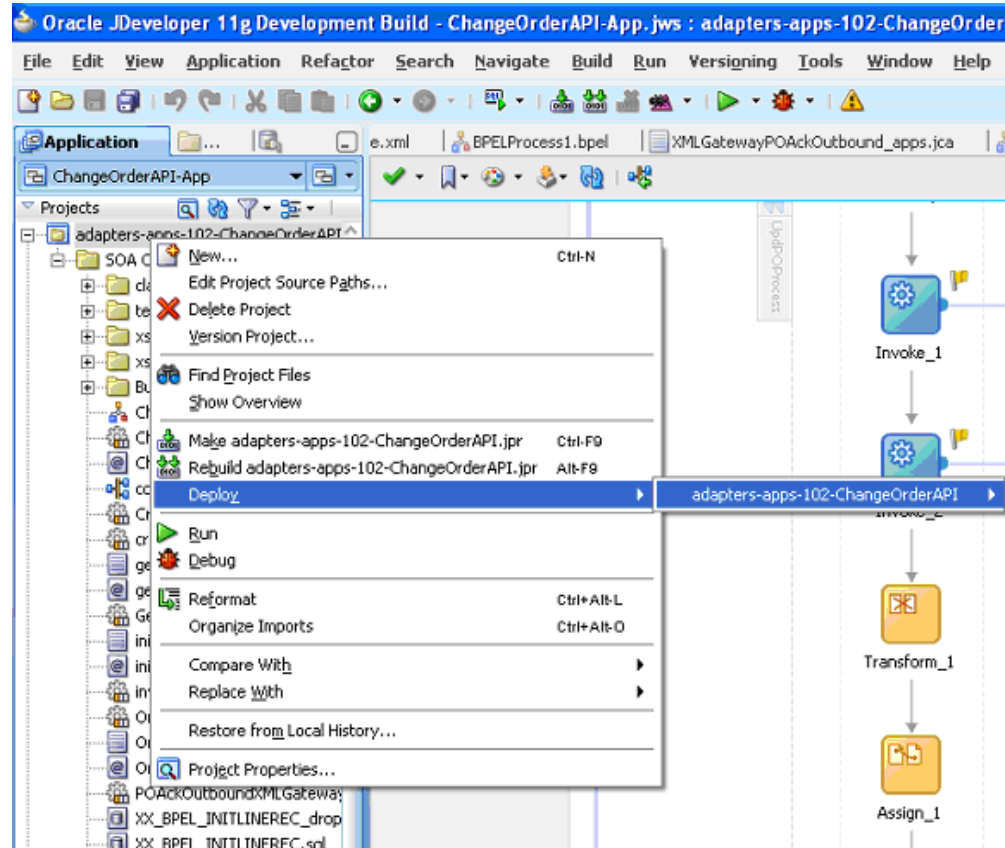

**Note:** If this is the first time to set up server connection, then the Deployment Action window appears. Select 'Deploy to Application Server' and click Next.

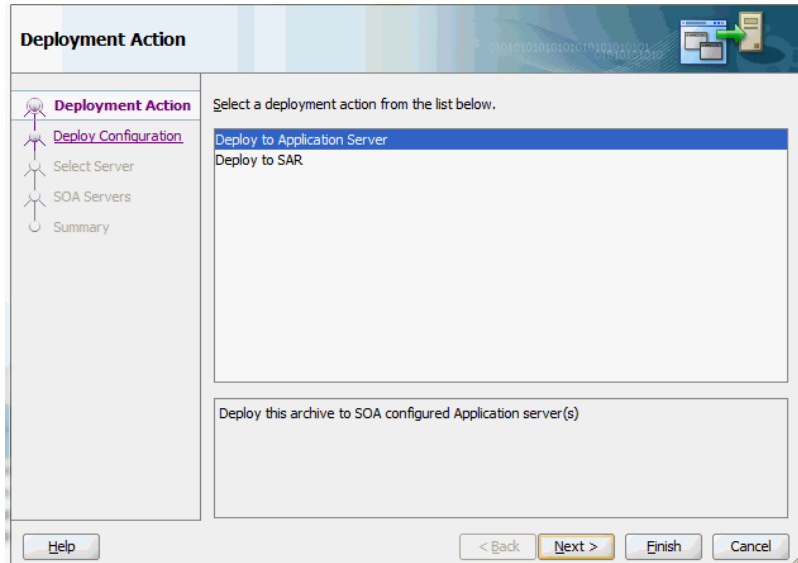

In the Deploy Configuration window, ensure the following information is selected before clicking **Next** to add a new application server:

- New Revision ID: 1.0
- Mark composite revision as default: Select this check box.
- Overwrite any existing composites with the same revision ID: Select this check box.

The steps to create a new Oracle WebLogic Server connection from JDeveloper are covered in [Creating an Application Server Connection](#), page A-12.

3. In the Select Server page, select 'soa-server1' that you have established the server connection earlier. Click **Next**.

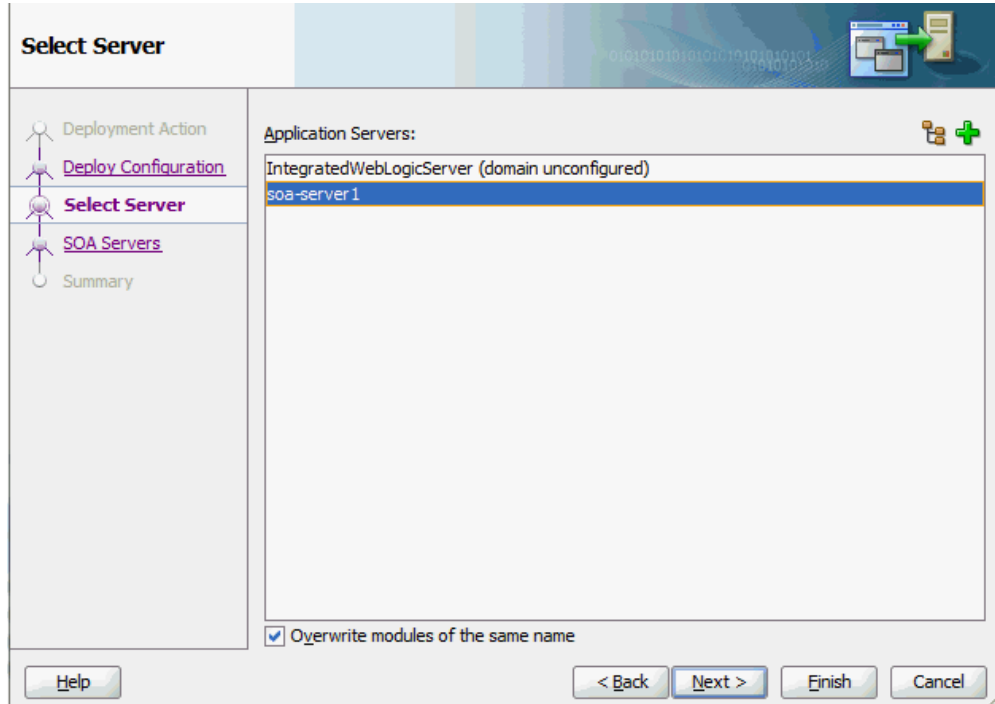

4. In the SOA Servers page, accept the default target SOA Server ('soa-server1') selection.

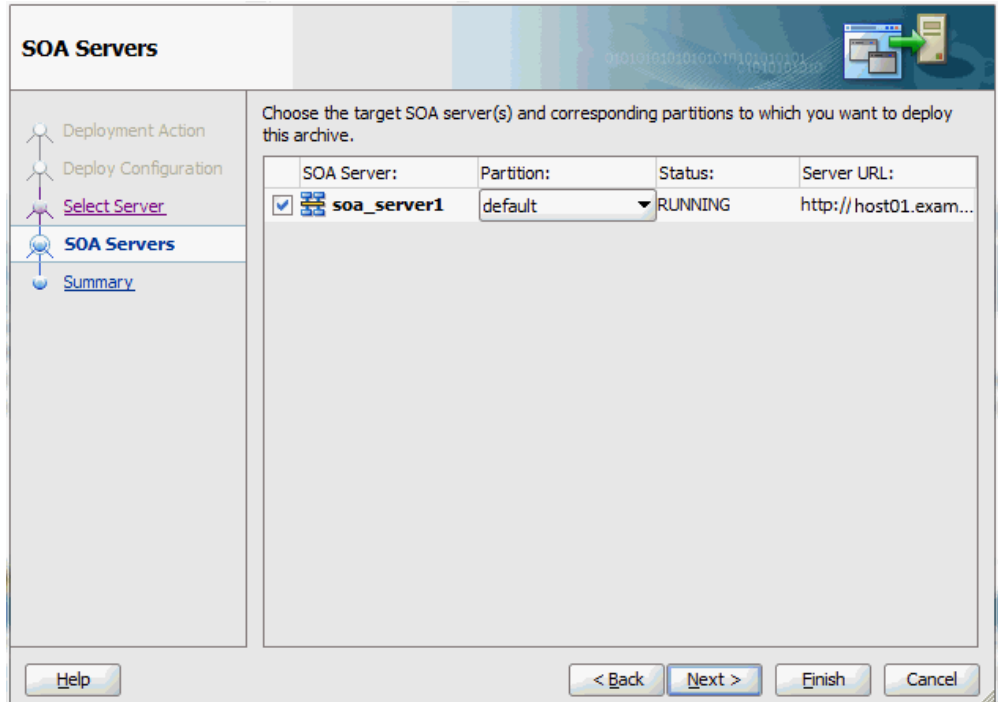

Click **Next** and **Finish**.

If you are deploying the composite for the first time from your Oracle JDeveloper session, the Authorization Request window appears. Enter username and password information specified during Oracle SOA Suite installation. Click **OK**.

5. Deployment processing starts. Monitor deployment progress and check for successful compilation in the SOA - Log window as well as in the Deployment - Log window.

## Testing the Deployed SOA Composite Application with BPEL Process

Once the BPEL process contained in a SOA Composite application is deployed, you can manage and monitor the process from the Oracle Enterprise Manager Fusion Middleware Control Console. You can also test the process and the integration interface by manually initiating the process.

### To test the deployed SOA Composite application with BPEL process:

1. Navigate to Oracle Enterprise Manager Fusion Middleware Control Console (<http://<servername>:<portnumber>/em>). The composite you deployed is displayed in the Applications Navigation tree.

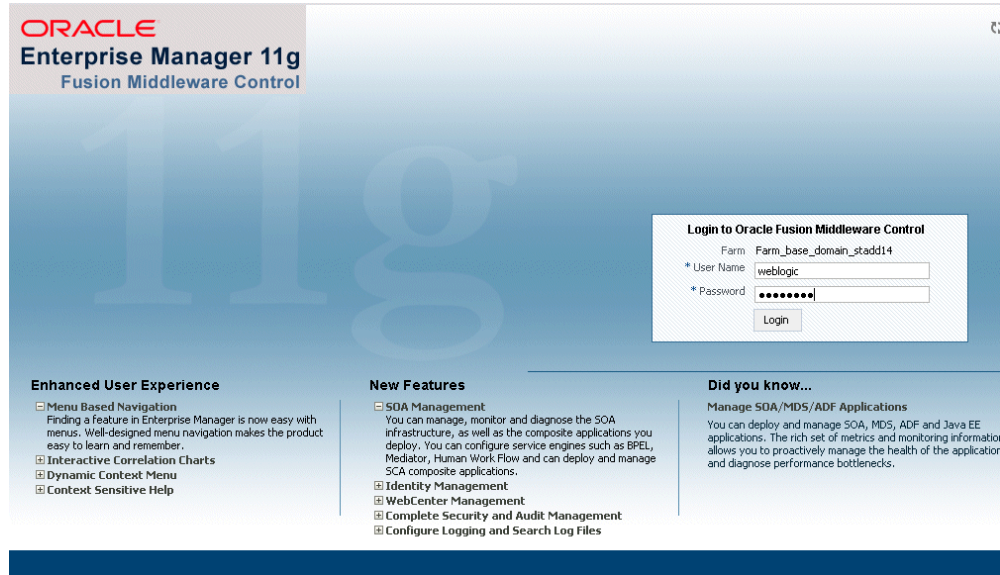

2. Enter username (such as `weblogic`) and password and click **Login** to log in to a farm.

You may need to select an appropriate target instance farm if there are multiple target Oracle Enterprise Manager Fusion Middleware Control Console farms.

3. From the Farm base domain, expand the **SOA >soa-infra** to navigate through the SOA Infrastructure home page and menu to access your deployed SOA Composite applications running in the SOA Infrastructure for that managed server.

**Note:** The Farm menu always displays at the top of the navigator. As you expand the SOA folder in the navigator and click the links displayed beneath it, the SOA Infrastructure menu becomes available at the top of the page.

Click the SOA Composite application that you want to initiate (such as 'ChangeOrderAPI') from the SOA Infrastructure.

## Viewing Deployed SOA Composites

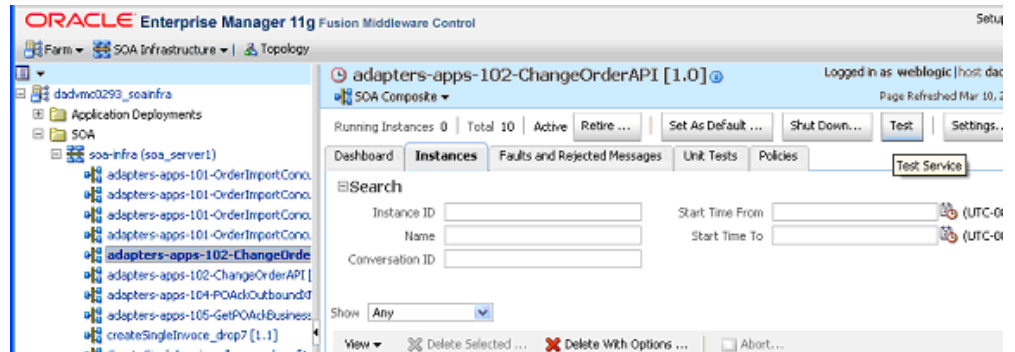

Click **Test** at the top of the page.

4. The Test Web Service page for initiating an instance appears. You can specify the XML payload data to use in the Input Arguments section.

Enter the input string required by the process and click **Test Web Service** to initiate the process.

### Testing Web Service

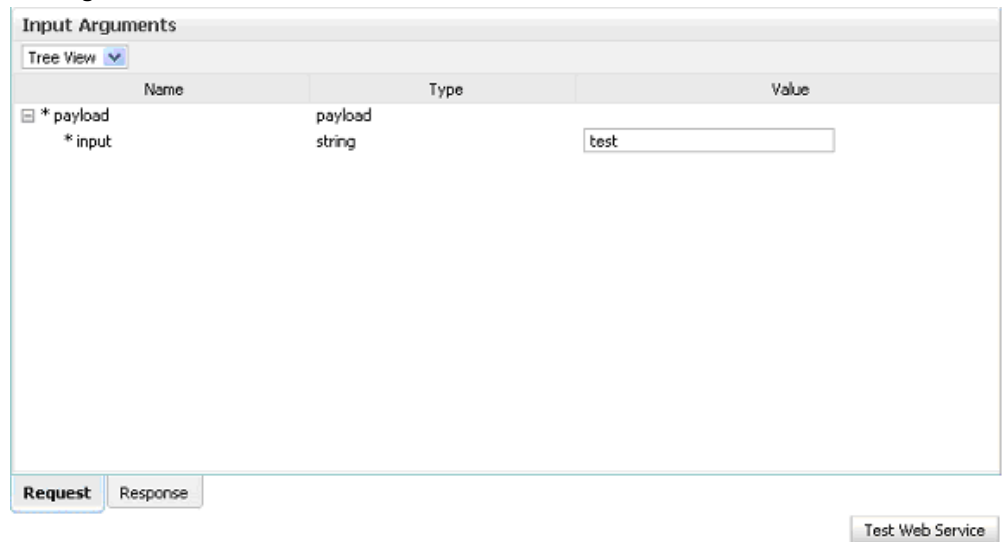

The test results appear in the Response tab upon completion.

5. Click on the SOA Composite application name and then click the Instances tab. The SOA Composite application instance ID, name, conversation ID, most recent known state of each instance since the last data refresh of the page are displayed.

In the Instance ID column, click a specific instance ID to show the message flow

through the various service components and binding components. The Flow Trace page is displayed.

In the Trace section, you should find the sequence of the message flow for the service binding component (`changeorderapi_client_ep`), BPEL component (`ChangeOrderAPI`), and reference binding components (`getOrderDetails`, `initLineRec`, and `OrderManagement`). All involved components have successfully received and processed messages.

### Flow Trace Page

The screenshot shows the 'Flow Trace' page. At the top, it displays the message flow diagram. Below that, the 'Trace' section contains a table with the following data:

Instance	Type	State	Time	Composite Instance
changeorderapi_client_ep	Service	Completed	Mar 1, 2009 11:08:14 PM	adapters-apps-102-Chan
ChangeOrderAPI	BPEL Component	Completed	Mar 1, 2009 11:08:16 PM	adapters-apps-102-Chan
getOrderDetails	Reference	Completed	Mar 1, 2009 11:08:14 PM	adapters-apps-102-Chan
initLineRec	Reference	Completed	Mar 1, 2009 11:08:15 PM	adapters-apps-102-Chan
OrderManagement	Reference	Completed	Mar 1, 2009 11:08:16 PM	adapters-apps-102-Chan

Click your BPEL service component instance link (such as `ChangeOrderAPI`) to display the Instances page where you can view execution details for the BPEL activities in the Audit Trail tab.

Click the Flow tab to check the BPEL process flow diagram. Click an activity of the process diagram to view the activity details and flow of the payload through the process.

### Validating Records Using SQL

To confirm that the records have been written into the Oracle Applications, you can write SQL `select l.ordered_quantity from oe_order_lines_all l,oe_order_headers_all h where h.orig_sys_document_ref='<ORDER_ID> and h.header_id=l.header_id;` statements and fetch the results showing the `ordered_quantity` should be the same as the value provided in the `changeorder_data.xml` document.

### Verifying Records in Oracle Applications

Alternatively, you can go to the specific module in Oracle Applications with Oracle Management Super User, Vision Operation (USA) responsibility.

#### To validate it in Oracle Order Management:

1. Log on to the Forms-based Oracle Applications with the Order Management,



Super User responsibility.

2. Select Order Returns > Sales Order. Sales Order Forms would open up.
3. Search for an order by entering the order number in the Customer PO field. This would bring up the details of a newly created order.
4. Select the Line Items tab to check the quantity of the order. It should be the same as it is set in `changeorder_data.xml` file.

## Troubleshooting

If you experience problems with your PL/SQL API integration, you can take the following troubleshooting steps:

- If you designed your PL/SQL API integration in one instance of your Oracle Applications environment, and plan to run it in another instance, be sure to rerun the SQL scripts in the second instance to create the necessary PL/SQL wrappers.
- Ensure that the JNDI location in **weblogic-ra.xml** is properly configured.

Enable logging for Adapter to see if the issue is on the middleware side. How to enable logging for Adapter for Oracle Applications, see *Enabling Logging for Adapters*, page 4-82.



---

## Using e-Commerce Gateway

This chapter covers the following topics:

- Overview of e-Commerce Gateway Integration
- Design-Time Tasks for e-Commerce Gateway
- Creating a New SOA Composite Application with BPEL Process
- Adding a Partner Link
- Adding a Partner Link for File Adapter
- Configuring Invoke Activities
- Configuring an Assign Activity
- Run-Time Tasks for e-Commerce Gateway
- Deploying the SOA Composite Application with BPEL Process
- Testing the Deployed SOA Composite Application with BPEL Process
- Verifying Records in Oracle E-Business Suite

### Overview of e-Commerce Gateway Integration

Oracle e-Commerce Gateway provides a common, standards-based approach for Electronic Data Interchange (EDI) integration between Oracle E-Business Suite and third party applications. EDI is the computer to computer exchange of business documents in a standard format. The EDI format is commonly used for e-commerce transactions between businesses.

Oracle e-Commerce Gateway is the EDI integration enabler for Oracle E-Business Suite. It provides a single integration framework for you to conduct e-business using EDI standards with everyone in your global supply chain. Oracle e-Commerce Gateway provides an application integration infrastructure that is flexible enough to accommodate the integration requirements of any and all applications that must integrate with Oracle E-Business Suite. This allows for seamless flow of information in an ever expanding trading partner base.

Oracle e-Commerce Gateway includes prebuilt transactions of key business documents that can be implemented simply by defining a trading partner and enabling the transaction in test or production mode. You can implement a single transaction, a group of transactions, or a business flow. You can implement the prebuilt transactions as is or configure them to meet your specific industry needs.

Oracle e-Commerce Gateway uses a metadata driven approach to dynamically generate outbound and consume inbound flat files based on user defined trading partner, mapping, transformation, and data validation rules. You can change a rule by changing the metadata stored in the repository. The updated rule takes effect at run-time without any code modifications.

**Note:** For detailed information about Oracle e-Commerce Gateway, see *Oracle e-Commerce Gateway User's Guide*. This guide is part of the Oracle E-Business Suite Documentation Library which can be accessed on the Oracle Technology Network (OTN).

Adapter for Oracle Applications can be configured to use e-Commerce Gateway to interact with third party applications. e-Commerce Gateway, like XML Gateway, is primarily used for Business-to-Business (B2B) integration. While XML transactions are mostly based on a single transaction and are event based, EDI transactions are more batch oriented.

## Design-Time Tasks for e-Commerce Gateway

Adapter for Oracle Applications is deployed using the BPEL Process Manager (PM) in Oracle JDeveloper. The BPEL PM creates the WSDL interfaces for the e-Commerce Gateway.

This section describes configuring the Adapter for Oracle Applications to use e-Commerce Gateway. It describes the tasks required to configure Adapter for Oracle Applications using the Adapter Configuration Wizard in Oracle JDeveloper.

### SOA Composite Application with BPEL Process Scenario

This example uses IN: Ship Notice/Manifest (ECASNI) EDI concurrent program exposed as a Web service to support the inbound Ship Notice/Manifest transaction.

When a shipment request is received, the shipping details will be retrieved and then imported to the Purchasing system to create an electronic shipment notice as a pre-receipt.

When the SOA Composite application with BPEL process has been successfully executed after deployment, you should be able to validate if the shipment notice has been inserted in Oracle Applications with the same shipment identifier number.

### Prerequisites to Configure e-Commerce Gateway

#### *Populating Applications Context Header Variables*

You need to populate certain variables in the BPEL PM in order to provide context information for Oracle Applications. The context information is required for an EDI transaction in order for an Oracle Applications user that has sufficient privileges to run the program.

The context is set taking into account the values passed for the header properties including *Username*, *Responsibility*, *Responsibility Application*, *Security Group*, and *NLS Language*. If the values for the new header properties *Responsibility Application*, *Security Group*, and *NLS Language* are not passed, context information will be determined based on *Username* and *Responsibility*.

The default Username is SYSADMIN, the default Responsibility is SYSTEM ADMINISTRATOR, the default Security Group Key is Standard, and the default NLS Language is US.

You can change the default values specified in the generated WSDL. This is a static way of changing the context information. These values would apply to all invocations of the deployed business process. However, if you need to provide different context information for different invocations of the business process, then you can dynamically populate the header values. The context information can be specified by configuring an Invoke activity.

For more information about applications context, see Supporting for Normalized Message Properties, page 4-7.

Based on the scenario described earlier, the following design-time tasks are discussed in this chapter.

1. Create a new SOA Composite application with BPEL process, page 10-3
2. Add a partner link, page 10-8
3. Add a partner link for File Adapter, page 10-15
4. Configure Invoke activities, page 10-20
5. Configure an Assign activity, page 10-25

## Creating a New SOA Composite Application with BPEL Process

The first configuration task is to create a new SOA Composite application with BPEL process.

### **To create a new SOA Composite application with BPEL process:**

1. Launch Oracle JDeveloper.
2. Click **New Application** in the Application Navigator.

The Create SOA Application - Name your application page is displayed.

### The Create SOA Application - Name your application Page

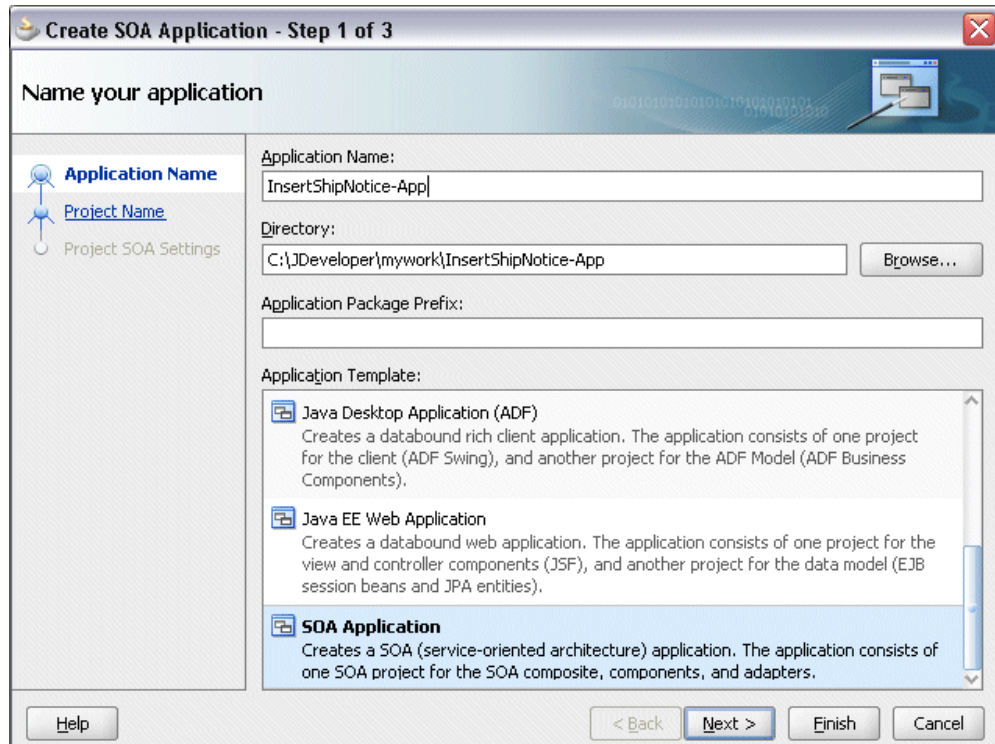

3. Enter an appropriate name for the application in the **Application Name** field and select **SOA Application** from the Application Template list.

Click **Next**. The Create SOA Application - Name your project page is displayed.

4. Enter an appropriate name for the project in the **Project Name** field. For example, InsertShipNotice.

### The Create SOA Application - Name your project Page

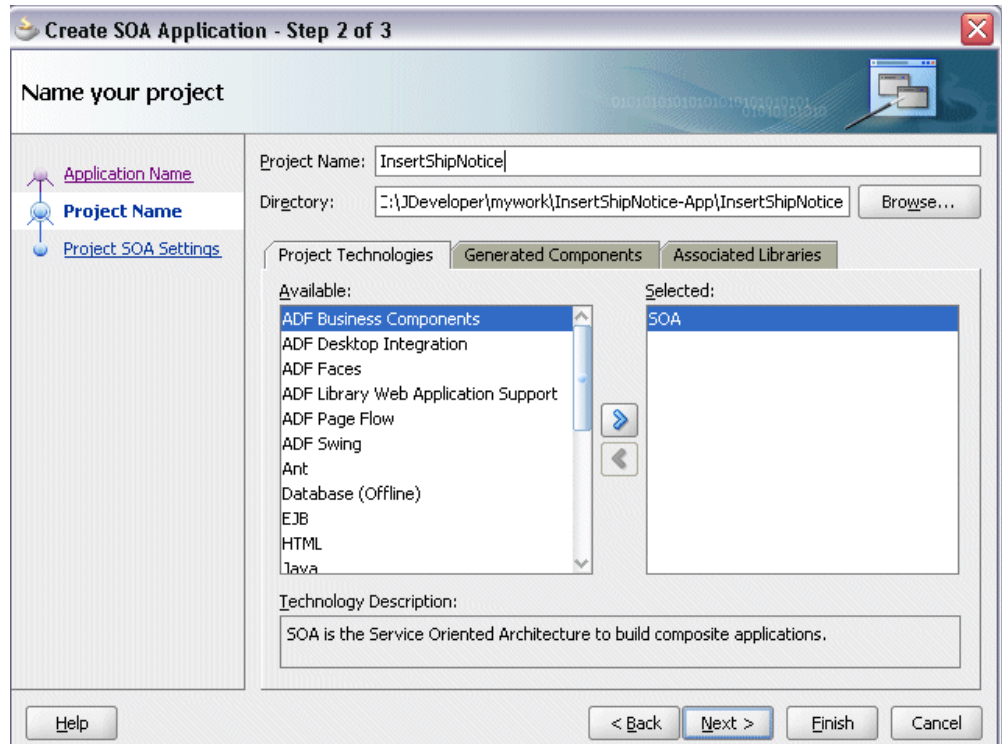

5. In the Project Technologies tab, ensure that **SOA** is selected from the Available technology list to the Selected technology list.

Click **Next**. The Create SOA Application - Configure SOA settings page is displayed.

### The Create SOA Application - Configure SOA settings Page

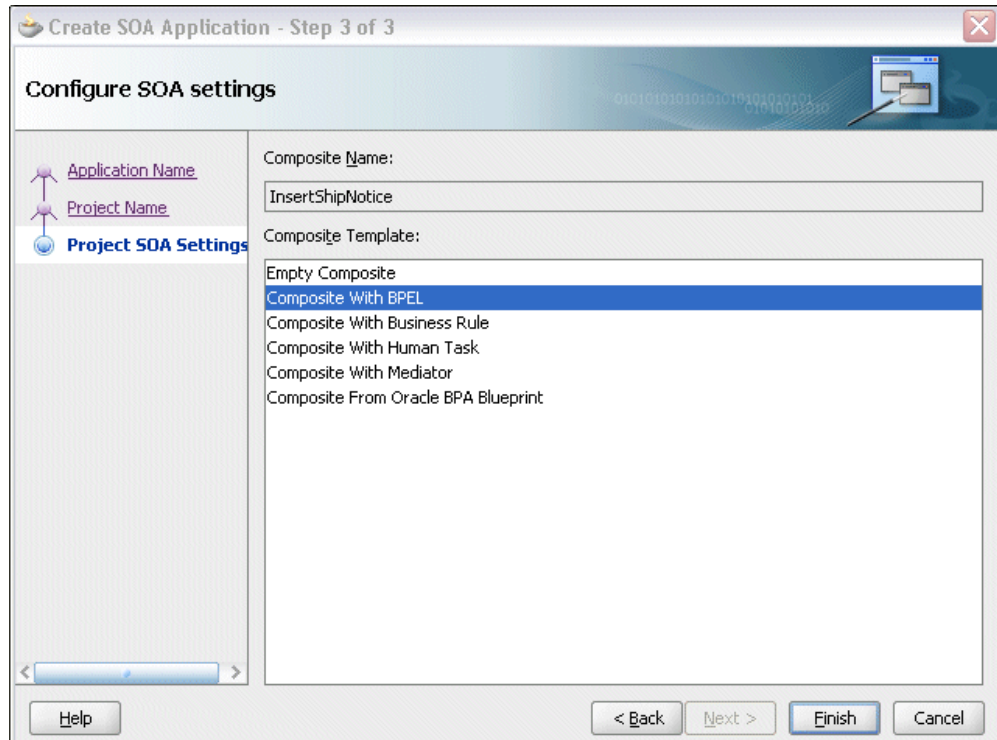

6. Select **Composite With BPEL** from the Composite Template list, and then click **Finish**. You have created a new application, and a SOA project. This automatically creates a SOA Composite application

The Create BPEL Process page is displayed.



### The Create BPEL Process Page

**BPEL Process**

A BPEL process is a service orchestration, based on the BPEL specification, used to describe/execute a business process (or large grained service), which is implemented as a stateful service.

BPEL 1.1 Specification  BPEL 2.0 Specification

Name:

Namespace:

Template:

Service Name:

Expose as a SOAP service

Delivery:

Input:

Output:

Help OK Cancel

7. Leave the default **BPEL 1.1 Specification** selection unchanged. This creates a BPEL project that supports the BPEL 1.1 specification.

Enter an appropriate name for the BPEL process in the **Name** field. For example, `InsertShipNotice`.

Select **Asynchronous BPEL Process** in the **Template** field. Click **OK**.

An asynchronous BPEL process is created with the Receive and Reply activities. The required source files including `bpel` and `wSDL`, using the name you specified (for example, `InsertShipNotice.bpel` and `InsertShipNotice.wSDL`) and `composite.xml` are also generated.

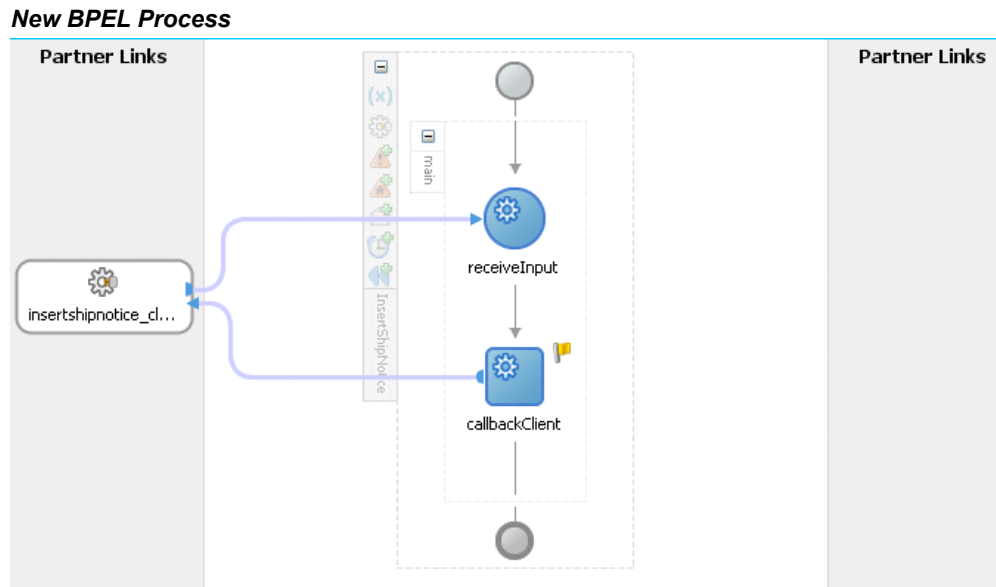

## Adding a Partner Link

The next task is to add a partner link to the BPEL process. A partner link defines the link name, type, and the role of the BPEL process that interacts with the partner service.

Based on the BPEL process scenario, you need to create a partner link to create a ship notice.

### To add a partner link:

1. Click **BPEL Services** in the Component palette.

Drag and drop **Oracle Applications** from the BPEL Services list into the right Partner Link swim lane of the process diagram. The Adapter Configuration Wizard Welcome page appears. Click **Next**.

2. Enter a service name in the **Service Name** field. For example, `InsertShipment`. Click **Next**. The Service Connection page appears.

### Specifying a Database Service Connection

The screenshot shows a window titled "Adapter Configuration Wizard - Step 3 of 4" with a close button in the top right corner. The main heading is "Service Connection". Below the heading, there is a descriptive text: "A Database Connection is required to configure this adapter. Select a database connection already defined in your project or create a New Connection." The "Connection:" field is a dropdown menu with "OracleAppsConnection" selected. To the right of the dropdown are three icons: a green plus sign, a pencil, and a key. Below the dropdown, the following fields are displayed: "User Name: apps", "Driver: oracle.jdbc.OracleDriver", and "Connect String: jdbc:oracle:thin:@localhost:1521:sid01". A note follows: "Specify the JNDI name for the database. Note: The deployment descriptor of the Oracle Applications adapter must associate this JNDI name with configuration properties required by the adapter to access the database." The "JNDI Name:" field contains the text "eis/Apps/OracleAppsConnection". At the bottom of the window, there are four buttons: "Help", "< Back", "Next >", "Finish", and "Cancel".

3. You can perform either one of the following options for your database connection:

**Note:** You need to connect to the database where Oracle Applications is running.

- You can create a new database connection by clicking the **Create a New Database Connection** icon.

How to define a new database connection, see *Create a New Database Connection*, page 5-13.

- You can select an existing database connection that you have configured earlier from the **Connection** drop-down list.

The Service Connection page will be displayed with the selected connection information. The JNDI (Java Naming and Directory Interface) name corresponding to the database connection appears automatically in the **Database Server JNDI Name** field. Alternatively, you can specify a JNDI name.

**Note:** When you specify a JNDI name, the deployment descriptor of the Oracle Applications adapter must associate this JNDI name with configuration properties required by the adapter to access the database.

The JNDI name acts as a placeholder for the connection used when your service is deployed to the BPEL server. This enables you to use different databases for development and later for production.

**Note:** For more information about JNDI concepts, refer to *Oracle Fusion Middleware User's Guide for Technology Adapters*.

4. Once you have completed creating a new connection for the service, you can add an interface by browsing through the available list in Oracle Applications.

Click **Next**.

**For Oracle E-Business Suite Release 12:**

If you are connecting to Oracle E-Business Suite Release 12, then the **IREP File not present** dialog appears indicating that Adapter could not find the Oracle Integration Repository data file corresponding to the database you are connecting in your workspace. Absence of the data file would make browsing or searching of Integration Repository tree considerably slow. You can choose to extract the data file and create a local copy of the Integration Repository data file. Once it is created successfully, Adapter will pick it up automatically next time and retrieve data from your local Integration Repository.

You can select one of the following options:

- Click **Yes** to extract the Integration Repository data file.

### Extracting Integration Repository Data File

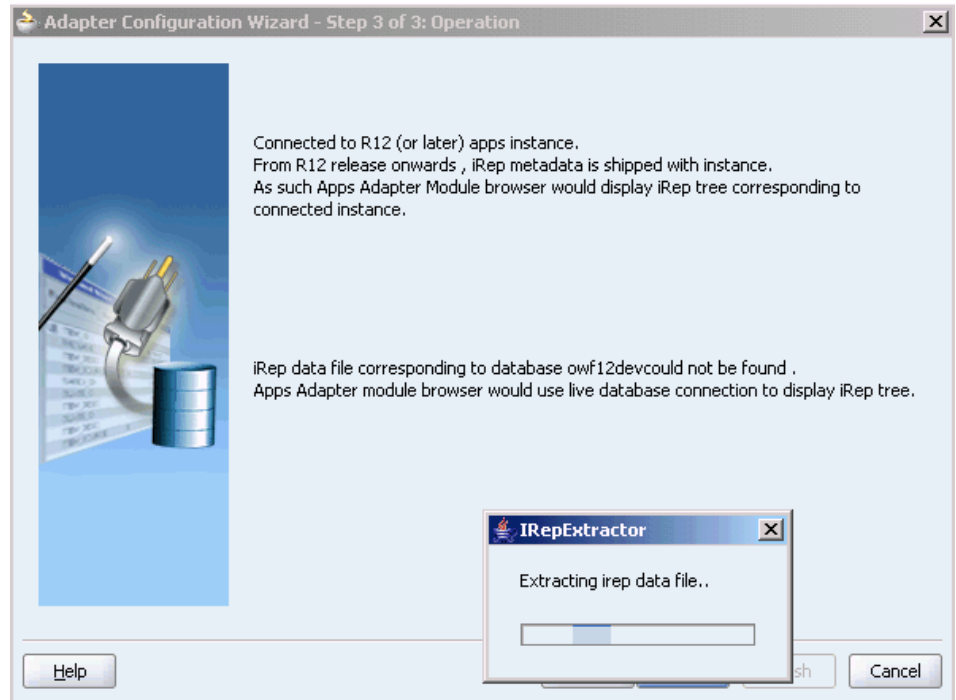

After the system successfully creates a local copy of the Integration Repository data file, next time when you connect to the database, you will find the **IRep Data File** field appears in the Operation dialog indicating where your local copy exists with the creation date and time as part of the file name.

### Using the Local Integration Repository Data File

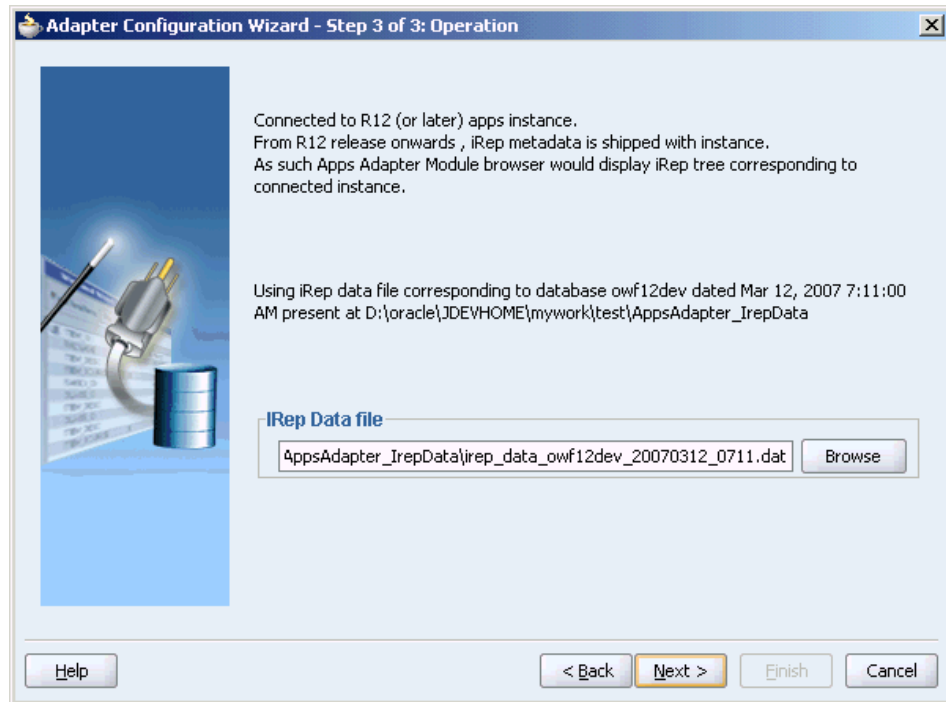

- Click **No** to query the Integration Repository data file from the live database you are connecting to display the Integration Repository tree.

Click **Next** in the Operation page to open the Oracle Applications Module Browser.

#### For Oracle E-Business Suite Release 11.5.9:

If you are connecting to an Oracle E-Business Suite Release 11.5.9 instance, you must select the interface type in the Adapter Configuration Wizard. Select **EDI Gateway** to proceed.

Click **Get Object** in the Application Interface dialog to open the Oracle Applications Module Browser.

5. Once you have identified an existing database connection or completed a new connection for the service, you can select an e-Commerce Gateway interface through Oracle Applications Module Browser.

**Note:** Oracle Applications Module Browser includes the various product families that are available in Oracle Applications. For example, Applications Technology or Order Management Suite are product families in Oracle Applications. The product families

contain the individual products. For example, Applications Technology contains the e-Commerce Gateway product. The product contains the business entities associated with the product. For example, the e-Commerce Gateway product contains the Advanced Shipment Notification business entity.

Business entities contain the various application modules that are exposed for integration. These modules are grouped according to the interface they provide. EDI programs can be found under the EDI category.

### Specify an Interface from The Oracle Applications Module Browser

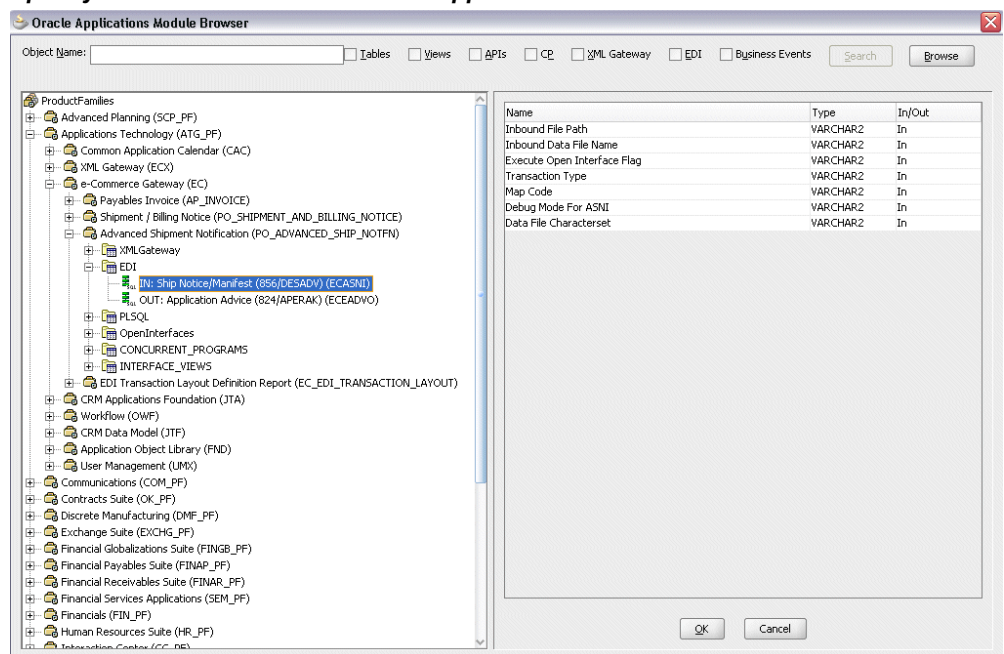

Select an inbound or outbound EDI program. You can select only one EDI program for each adapter service.

For example, navigate to *Product Families > Applications Technology > e-Commerce Gateway > Advanced Shipment Notification > EDI* to select **EDI > IN: Ship Notice/Manifest (856/DESADV) (ECASNI)** EDI concurrent program.

**Note:** You can also search for an EDI program by entering the name of the program in the **Object Name** field. Select the **EDI** check box and click **Search**.

6. Click **OK**.

The selected EDI concurrent program is added to Operation Objects.

### Adapter Configuration Wizard - Application Interface Page

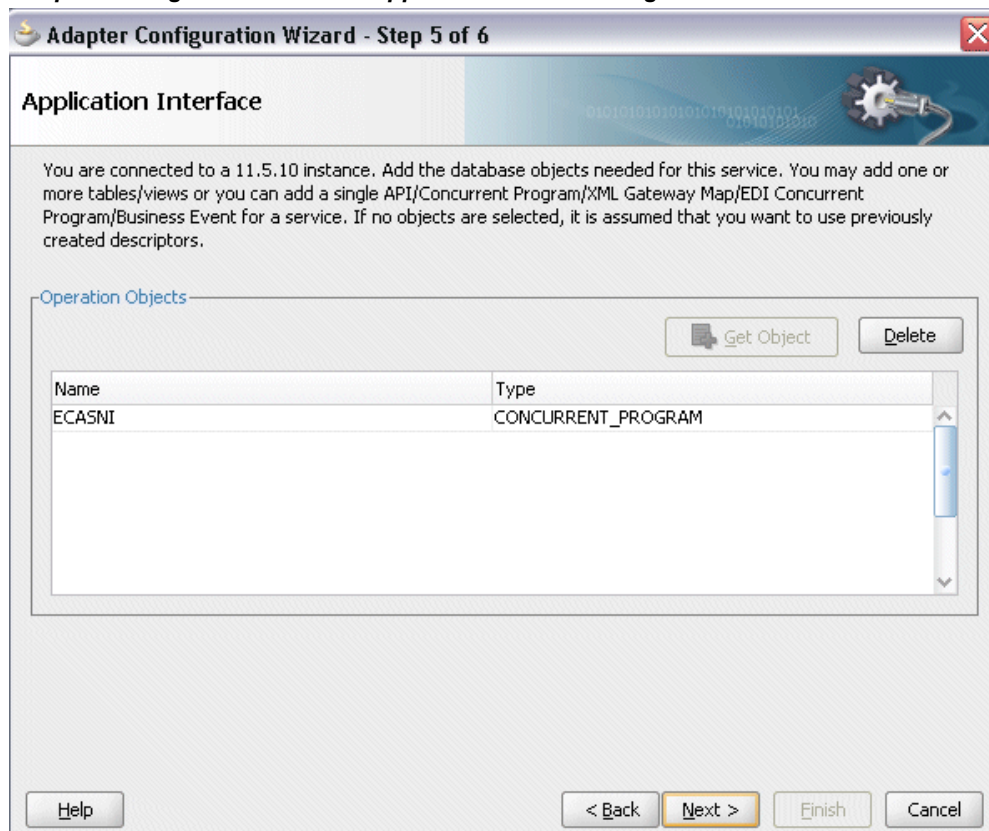

Click **Next**.

7. Click **Finish** to complete the process of configuring Adapter for Oracle Applications.

The wizard generates the WSDL file corresponding to the selected interface. This WSDL file is now available for the partner link.

**Note:** When you click **Finish**, two SQL files may be added to the project if a wrapper does not exist for the function. A wrapper is generated the very first time you create the e-Commerce Gateway based service. Subsequent services reuse the same wrapper.



### Completing the Partner Link Configuration

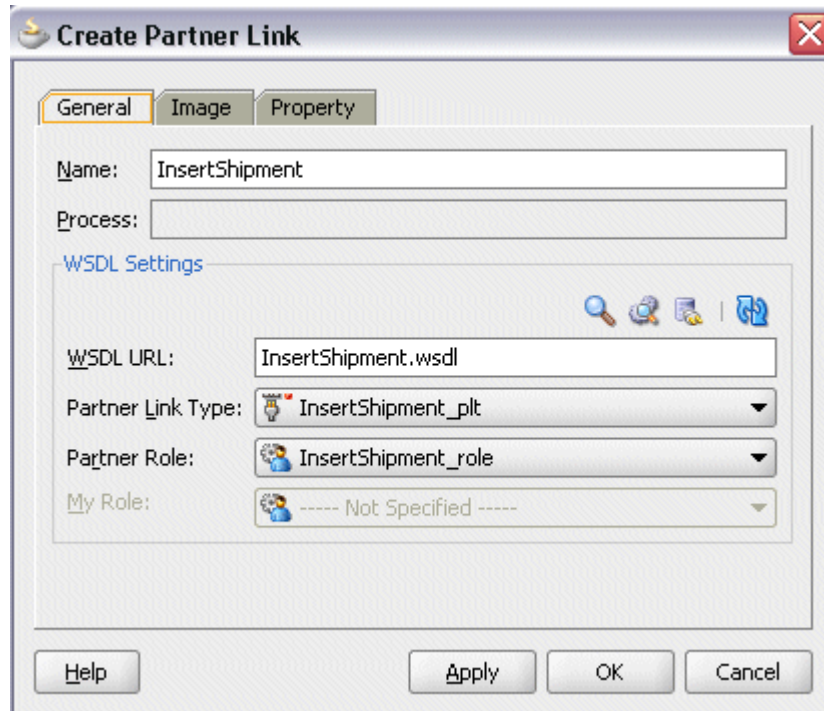

8. Click **Apply** and then **OK**. The partner link is created with the required WSDL settings.

## Adding a Partner Link for File Adapter

Use this step to configure a BPEL process by synchronously reading an existing order to obtain the shipping details.

### To add a Partner Link for File Adapter to read shipping details:

1. In JDeveloper BPEL Designer, click **BPEL Services** in the Component palette.  
Drag and drop **File Adapter** from the BPEL Services list into the right Partner Link swim lane of the process diagram before the partner link `InsertShipment`. The Adapter Configuration Wizard Welcome page appears.  
Click **Next**.
2. In the Service Name dialog, enter a name for the file adapter service, such as `getShippingDetails`.
3. Click **Next**. The Adapter Interface dialog appears.

## Specifying the Adapter Interface

The screenshot shows a window titled "Adapter Configuration Wizard - Step 3 of 4" with a close button in the top right corner. The main title is "Adapter Interface". Below the title is a decorative header with binary code and a gear icon. The main text reads: "The adapter interface is defined by a wsdl that is generated using the operation name and schema(s) specified later in this wizard. Optionally, the adapter interface may be defined by importing an existing WSDL." Below this text, there are two radio buttons under the label "Interface:". The first radio button is selected and labeled "Define from operation and schema (specified later)". The second radio button is labeled "Import an existing WSDL". Below the radio buttons are three input fields: "WSDL URL:" with a text box and a file icon, "Port Type:" with a dropdown menu, and "Operation:" with a dropdown menu. At the bottom of the window, there are five buttons: "Help", "< Back", "Next >", "Finish", and "Cancel".

Select the **Define from operation and schema (specified later)** radio button and click **Next**.

4. In the Operation dialog, specify the operation type. For example, select the **Synchronous Read File** radio button. This automatically populates the **Operation Name** field.

### Specifying the Operation

Adapter Configuration Wizard - Step 4 of 8

#### Operation

The File Adapter supports four operations. There is a Read File operation that polls for incoming files in your local file system, a Write File operation that creates outgoing files, a Synchronous Read File operation that reads the current contents of a file, and a List Files operation that lists file names in specified locations. Specify the Operation type and Operation Name. Only one operation per Adapter Service may be defined using this wizard.

Operation Type:  Read File  
 Write File  
 Synchronous Read File  
 List Files

Operation Name:

Help < Back Next > Finish Cancel

Click **Next** to access the File Directories dialog.

5. Select the **Logical Name** radio button and specify directory for incoming files, such as `inputDir`.

Ensure the **Delete files after successful retrieval** check box is not selected.

### Configuring the Input File

The screenshot shows a window titled "Adapter Configuration Wizard - Step 5 of 8" with a close button in the top right corner. The main heading is "File Directories". Below the heading, there is a text box with the instruction: "Enter directory information for the incoming file of the Synchronous Read File operation." Below this, there are two radio buttons: "Physical Path" (unselected) and "Logical Name" (selected). There are three input fields, each with a "Browse" button to its right. The first input field is labeled "Directory for Incoming Files (physical path):" and contains the text "inputDir". The second input field is labeled "Archive Directory for Processed Files (physical path):" and is currently empty. The third input field is labeled "Delete files after successful retrieval" and is also empty. At the bottom of the window, there are four buttons: "Help", "< Back", "Next >", and "Finish", followed by a "Cancel" button.

Click **Next** to open the File Name dialog.

6. Enter the name of the file for the synchronous read file operation. For example, enter `order_data.xml`. Click **Next** to open the Messages dialog.
7. Select the 'browse for schema file' icon to open the Type Chooser.

Click Type Explorer and select *Project Schema Files > APPS\_XX\_BPEL\_FND\_REQUEST\_WRAPPER\_SUBMIT\_REQUEST.xsd > InputParameters*.

The selected schema information will be automatically populated in the URL and Schema Element fields.

## Specifying Message Schema

**Adapter Configuration Wizard - Step 7 of 8**

### Messages

Define the message for the Synchronous Read File operation. Specify the Schema File Location and select the Schema Element that defines the messages in the incoming files. Use the Browse button to find an existing schema definition. If you check 'Schema is Opaque', then you do not need to specify a Schema.

Message Schema

Native format translation is not required (Schema is Opaque)

Define Schema for Native Format

URL: xsd/APPS\_XX\_BPFL\_FND\_REQUEST\_WRAPPER\_SUBMIT\_REQUEST.xsd

Schema Element: InputParameters

Help < Back **Next >** Finish Cancel

8. Click **Next** and then **Finish**. The wizard generates the WSDL file corresponding to the partner link. The main Create Partner Link dialog box appears, specifying the new WSDL file `getShippingDetails.wsdl`.

### Completing the Partner Link Configuration

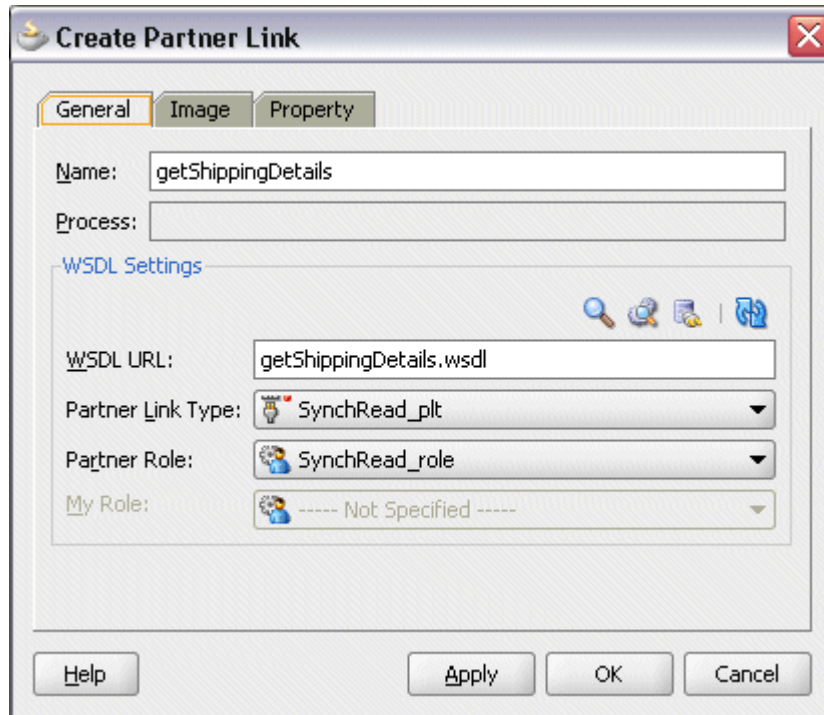

Click **Apply** and **OK** to complete the configuration and create the partner link with the required WSDL settings for the File Adapter service.

The `getShippingDetails` Partner Link appears in the BPEL process diagram.

## Configuring Invoke Activities

After adding and configuring the partner link, you can configure the following two **Invoke** process activities to invoke the EDI concurrent program and File Adapter partner link:

1. To get the shipping details that is received from the Receive activity by invoking the `getShippingDetails` partner link in an XML file.
2. To create a shipment notice by invoking `InsertShipment` partner link.

### To add the first Invoke activity for a partner link to get shipping details:

1. In Oracle JDeveloper BPEL Designer, expand the **BPEL Constructs** from the Component Palette. Drag and drop the first **Invoke** activity into the center swim lane of the process diagram, between the **receiveInput** and **callbackClient** activities.

2. Link the Invoke activity to the `getShippingDetails` service. The Edit Invoke dialog appears.
3. Enter a name for the Invoke activity, then click the **Create** icon next to the **Input Variable** field to create a new variable. The Create Variable dialog box appears.

#### Create Input Variable

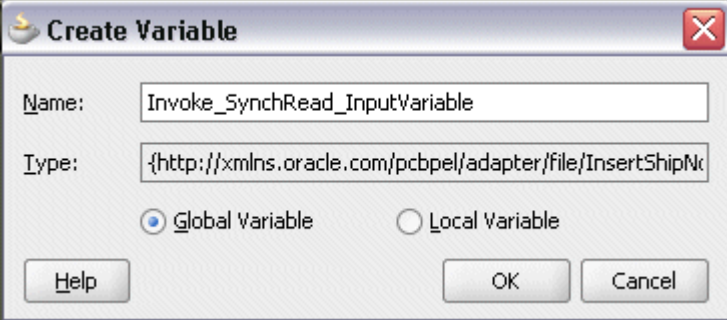

The screenshot shows a dialog box titled "Create Variable". It has a standard Windows-style title bar with a close button (red X) in the top right corner. The dialog contains the following elements:

- Name:** A text input field containing the text "Invoke\_SynchRead\_InputVariable".
- Type:** A text input field containing the text "{http://xmlns.oracle.com/pcbpel/adapter/file/InsertShipN".
- Global Variable:** A radio button that is selected (indicated by a blue dot).
- Local Variable:** An unselected radio button.
- Buttons:** Three buttons are located at the bottom: "Help" on the left, "OK" in the center, and "Cancel" on the right.

4. Select **Global Variable**, then enter a name for the variable. You can also accept the default name. Click **OK**.
5. Click the **Create** icon next to the **Output Variable** field to create a new variable. The Create Variable dialog box appears.
6. Select **Global Variable**, then enter a name for the variable. You can also accept the default name. Click **OK**.

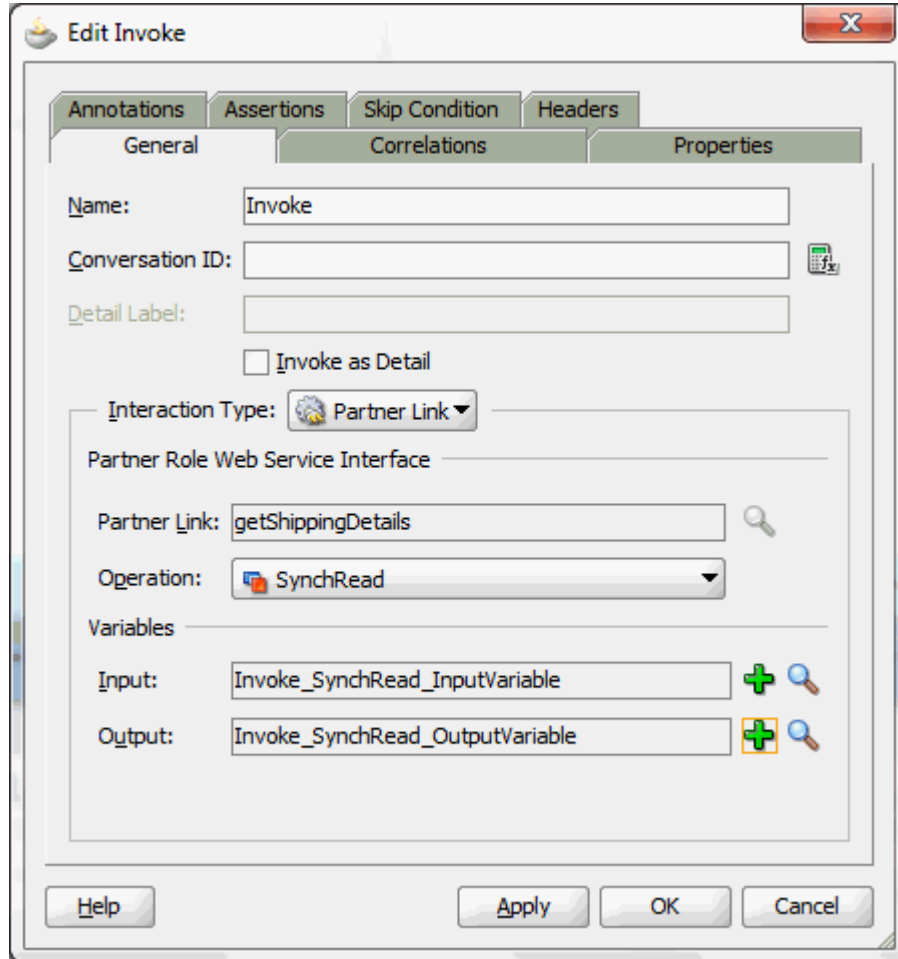

7. Click **Apply** and **OK** in the Edit Invoke dialog box to finish configuring the Invoke activity.

The Invoke activity appears in the process diagram.

**To add the second Invoke activity for a partner link to create a shipment notice:**

1. In Oracle JDeveloper BPEL Designer, expand the **BPEL Constructs** from the Component Palette. Drag and drop the third **Invoke** activity into the center swim lane of the process diagram, between the first **Invoke** and **callbackClient** activities.
2. Link the Invoke activity to the `InsertShipment` service. The Edit Invoke dialog box appears.

The **Operation** is automatically selected, depending on the EDI concurrent program that you chose when configuring the partner link.

3. Repeat Step 3 to Step 6 described in the first Invoke activity procedure.  
Click **Apply** and **OK**.



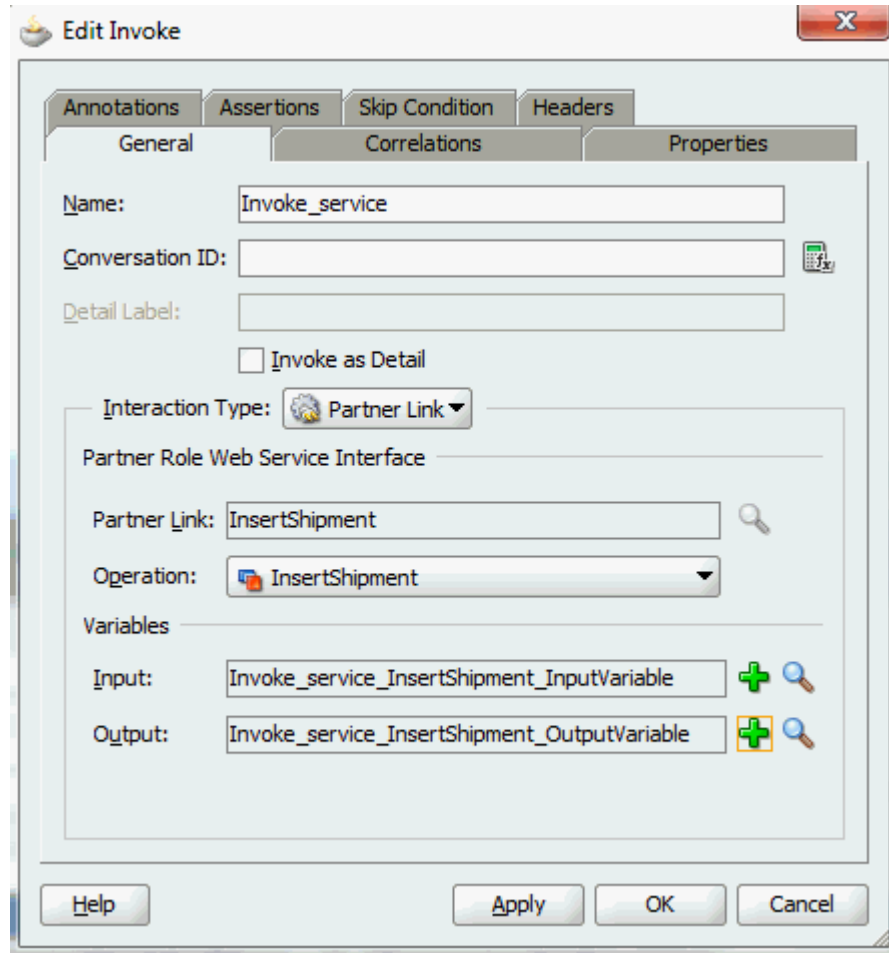

#### 4. Setting Header Properties for Applications Context

Use the following steps to set the header message properties required to pass applications context required to complete the BPEL process:

1. Select the Properties tab to set the Header message properties required to pass applications context required to complete the BPEL process.

### Setting Header Message Properties

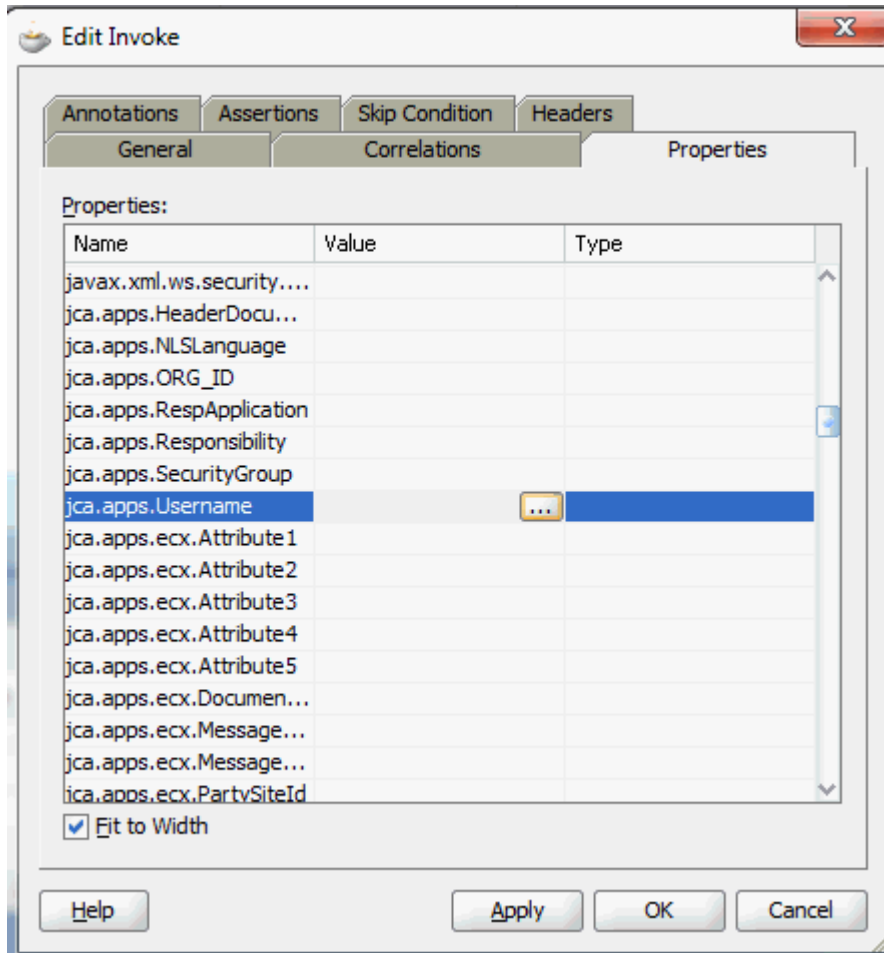

2. Scroll down to locate the `jca.apps.Username` property from the list and double click the associated value field to enable the **Adapter Property Value** icon.
3. Click the icon to open the Adapter Property Value dialog for the selected `jca.apps.Username` property.

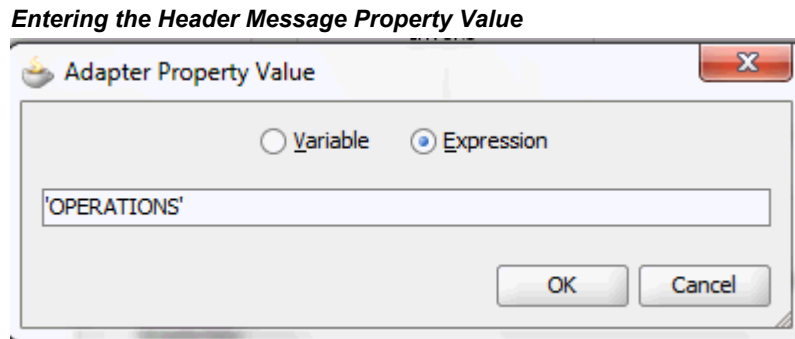

4. Select the **Expression** radio button and enter 'OPERATIONS' as the property value.  
Click **OK**.
5. Repeat Step 2 to Step 4 to assign 'Purchasing, Vision Operations (USA)' for `jca.apps.Responsibility`.
5. Click **Apply** and then **OK** to complete the Invoke activity.

## Configuring an Assign Activity

Use the Assign activity to pass the output of `getShippingDetails` service as an input to the `InsertShipment` service.

### To add an Assign activity:

1. In Oracle JDeveloper BPEL Designer, expand the **BPEL Constructs** from the Component Palette. Drag and drop the **Assign** activity into the center swim lane of the process diagram between the two **Invoke** activities that you just created earlier.
2. Double-click the **Assign** activity to access the Edit Assign dialog.  
Click the General tab to enter a name for the Assign activity. For example, `setShipInfo`.
3. Select the Copy Rules tab and expand the source and target trees:
  - In the From navigation tree, navigate to **Variable > Process > Variables > Invoke\_SynchRead\_OutputVariable > body** and select `ns3:InputParameters`.
  - In the To navigation tree, navigate to **Variable > Process > Variables > Invoke\_Service\_InsertShipment\_InputVariable > Input Parameters** and select `ns3:InputParameters`.

Drag the source node (ns3:InputParameters) to connect to the target node (ns3:InputParameters) that you just identified. This creates a line that connects the source and target nodes. The copy rule is displayed in the From and To sections at the bottom of the Edit Assign dialog box.

### Assigning Parameters

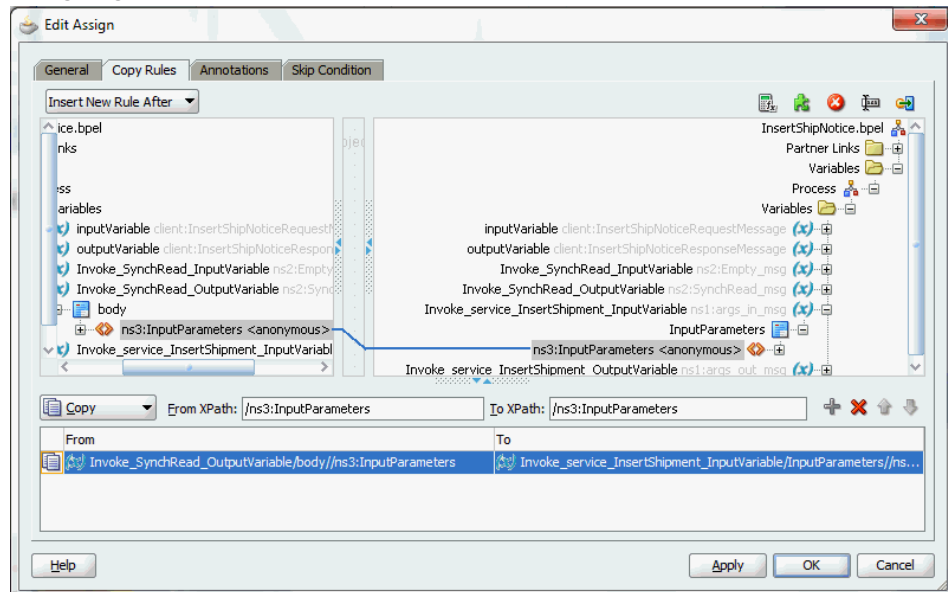

4. Click **Apply** and **OK** to complete the configuration of the Assign activity.

**Completed Concurrent Program BPEL Process Project**

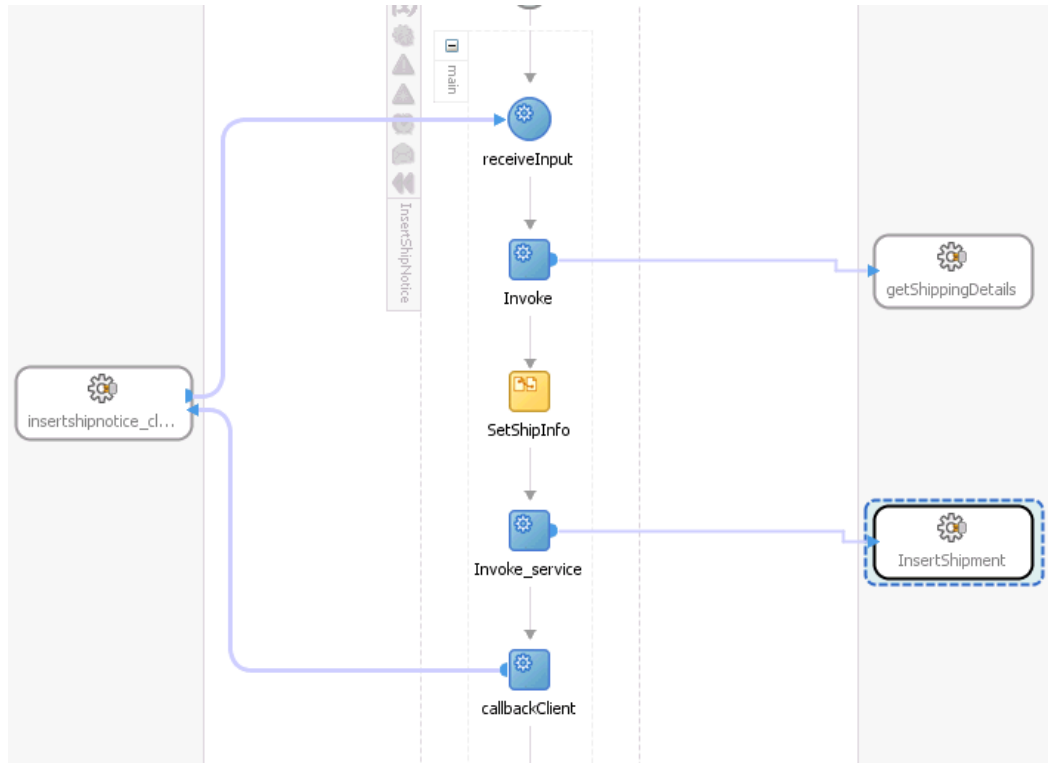

Click the composite.xml to display the Oracle JDeveloper composite diagram:

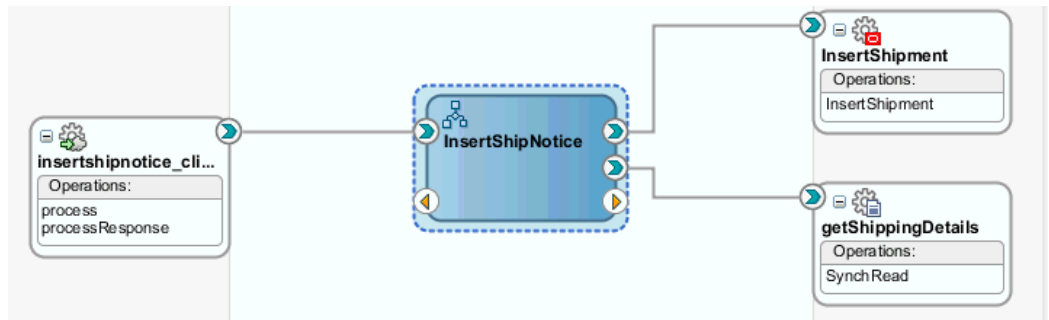

**Note:** Click the Source tab of composite.xml to enter a value for the physical directory inputDir for the reference getShippingDetails (such as /usr/tmp).

```
<property name="inputDir" type="xs:string"
many="false" override="may"/>/usr/tmp</property>
```

## Specifying the Physical Directory for the Property



```
<property name="bpel.config.oneWayDeliveryPolicy" type="xs:string"
many="false">async.persist</property>
</component>
<reference name="InsertShipment" ui:wSDLLocation="InsertShipment.wsdl">
<interface.wSDL interface="http://xmlns.oracle.com/pcbpel/adapter/apps/InsertShipNotice-
app" binding.jca config="InsertShipment_apps.jca"/>
<property name="jca.retry.count" type="xs:int" many="false" override="may">4</property>
<property name="jca.retry.interval" type="xs:int" many="false"
override="may">1</property>
<property name="jca.retry.backoff" type="xs:int" many="false"
override="may">2</property>
<property name="jca.retry.maxInterval" type="xs:string" many="false"
override="may">120</property>
</reference>
<reference name="getShippingDetails"
ui:wSDLLocation="getShippingDetails.wsdl">
<interface.wSDL interface="http://xmlns.oracle.com/pcbpel/adapter/file/InsertShipNotice-
app" binding.jca config="getShippingDetails_file.jca"/>
<property name="inputDir" type="xs:string" many="false" override="may">/usr/tmp</property>
</reference>
<wire>
<source.uri>insertshipnotice_client_ep</source.uri>
<target.uri>InsertShipNotice/insertshipnotice_client</target.uri>
</wire>
<wire>
<source.uri>InsertShipNotice/InsertShipment</source.uri>
<target.uri>InsertShipment</target.uri>
</wire>
</wire>
```

## Run-Time Tasks for e-Commerce Gateway

After designing the SOA Composite application with BPEL process, the next step is to deploy, run and monitor it.

1. Deploy the SOA Composite application with BPEL process, page 10-28
2. Test the deployed SOA Composite application with BPEL process, page 10-33
3. Verify records in Oracle E-Business Suite, page 10-36

## Deploying the SOA Composite Application with BPEL Process

To invoke the service (InsertShipment) from the BPEL client contained in the SOA composite, the SOA composite needs to be deployed to the Oracle WebLogic managed server. This can be achieved using Oracle JDeveloper. Once the composite is deployed, it can be tested from the Oracle Enterprise Manager Fusion Middleware Control Console.

### Prerequisites

Before deploying the SOA composite with BPEL process using Oracle JDeveloper, you must have established the connectivity between the design-time environment and the run-time server. For more information, see *Configuring the Data Source in Oracle*

WebLogic Server, page A-3 and Creating an Application Server Connection, page A-12.

**Note:** If a local instance of the WebLogic Server is used, start the WebLogic Server by selecting **Run > Start Server Instance** from Oracle JDeveloper. Once the WebLogic Admin Server "DefaultServer" instance is successfully started, the <Server started in Running mode> and DefaultServer started message in the Running:DefaultServer and Messages logs should appear.

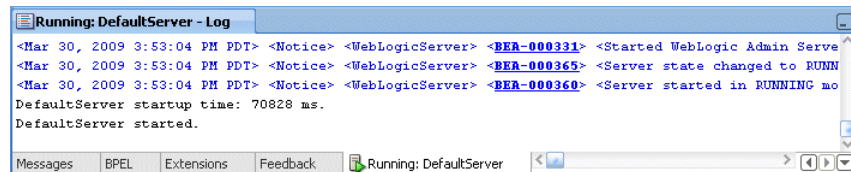

```
Running: DefaultServer - Log
<Mar 30, 2009 3:53:04 PM PDT> <Notice> <WebLogicServer> <BEA-000331> <Started WebLogic Admin Serve
<Mar 30, 2009 3:53:04 PM PDT> <Notice> <WebLogicServer> <BEA-000365> <Server state changed to RUNN
<Mar 30, 2009 3:53:04 PM PDT> <Notice> <WebLogicServer> <BEA-000360> <Server started in RUNNING mo
DefaultServer startup time: 70828 ms.
DefaultServer started.
```

### To deploy the SOA Composite application with BPEL process:

1. Select the SOA Composite project in the Applications Navigator.
2. Right-click the project name, and then select **Deploy > [project name] > [serverConnection]** from the menu that appears.

For example, you can select **Deploy > InsertShipNotice > soa-server1** to deploy the process if you have the connection set up appropriately.

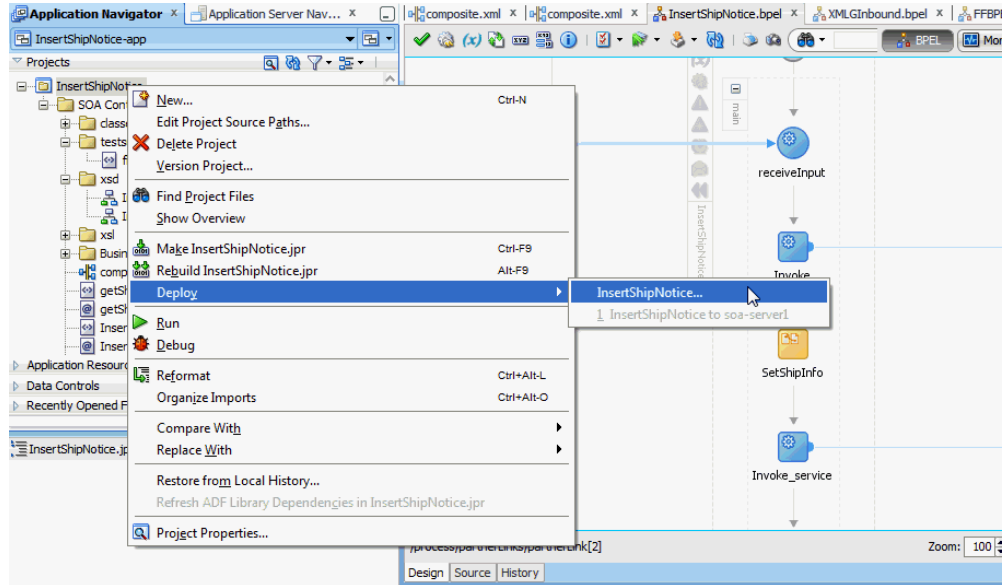

**Note:** If this is the first time to set up server connection, then the Deployment Action window appears. Select 'Deploy to Application Server' and click **Next**.



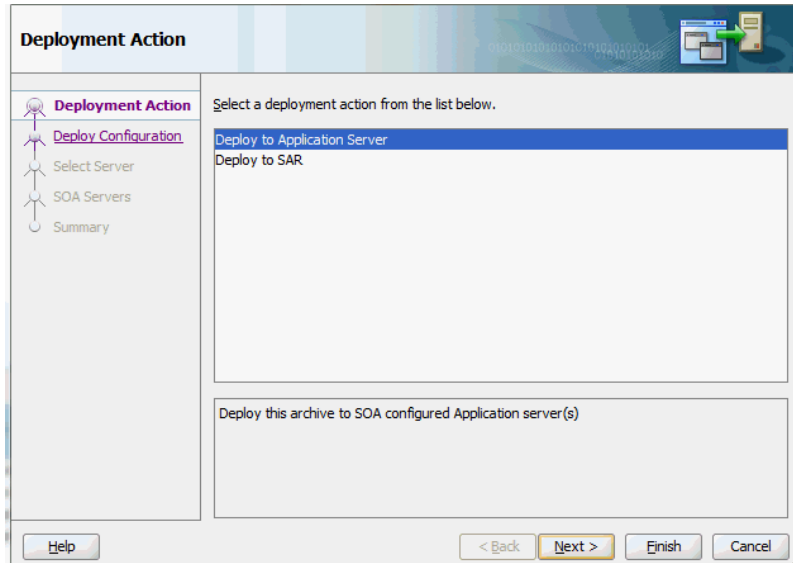

In the Deploy Configuration window, ensure the following information is selected before clicking **Next** to add a new application server:

- New Revision ID: 1.0
- Mark composite revision as default: Select this check box.
- Overwrite any existing composites with the same revision ID: Select this check box.

The steps to create a new Oracle WebLogic Server connection from JDeveloper are covered in *Creating an Application Server Connection*, page A-12.

3. In the Select Server page, select 'soa-server1' that you have established the server connection earlier. Click **Next**.

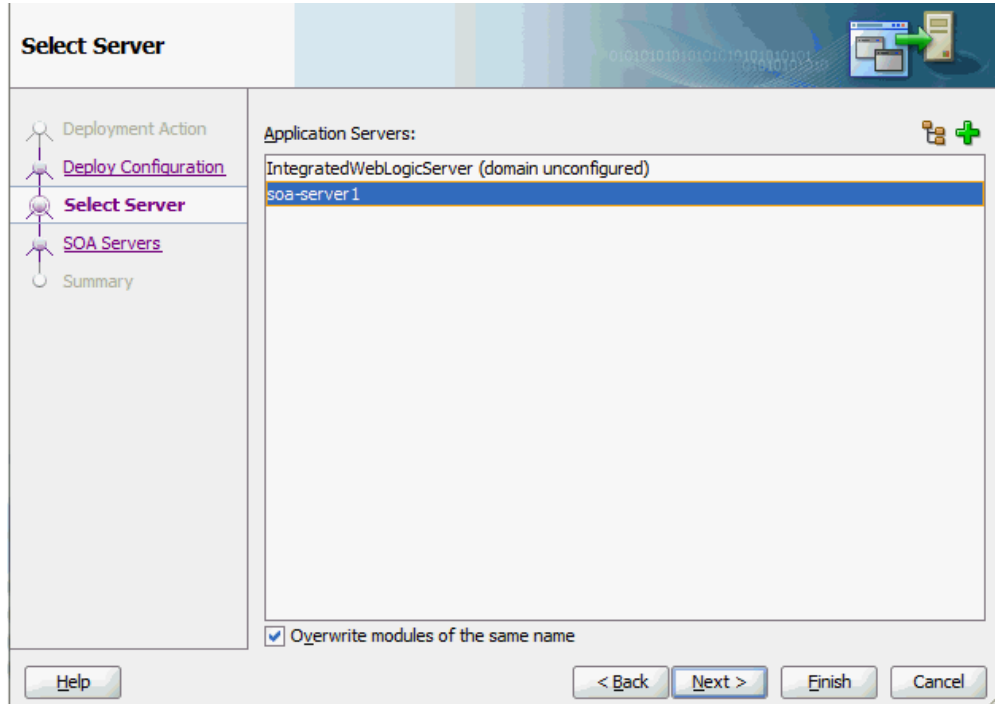

4. In the SOA Servers page, accept the default target SOA Server ('soa-server1') selection.

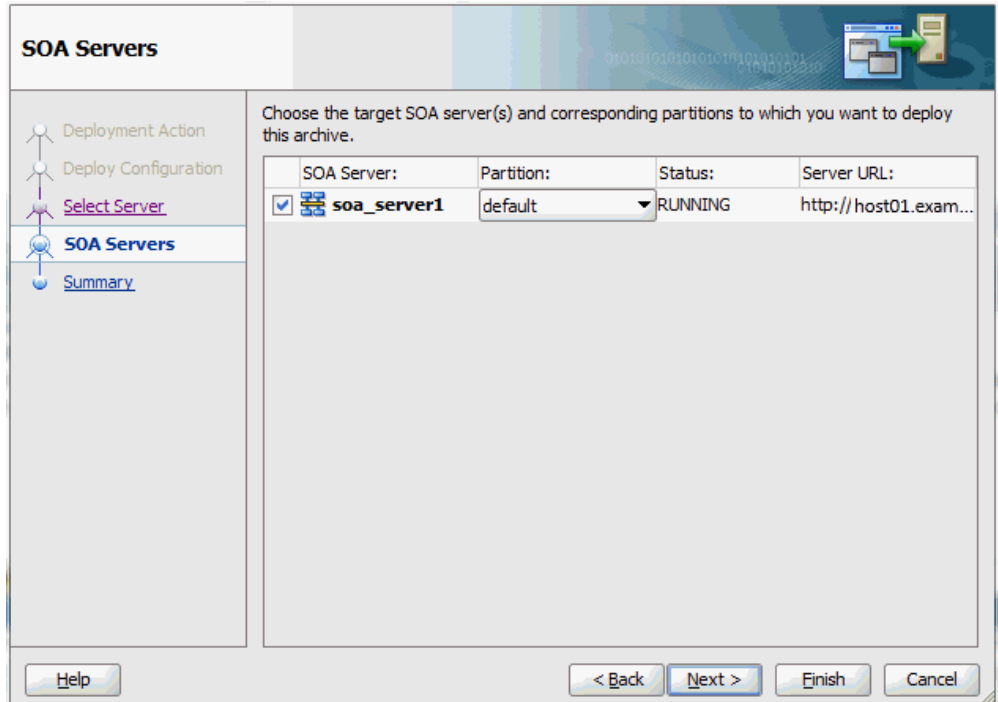

Click **Next** and **Finish**.

If you are deploying the composite for the first time from your Oracle JDeveloper session, the Authorization Request window appears. Enter username and password information specified during Oracle SOA Suite installation. Click **OK**.

5. Deployment processing starts. Monitor deployment progress and check for successful compilation in the SOA - Log window.

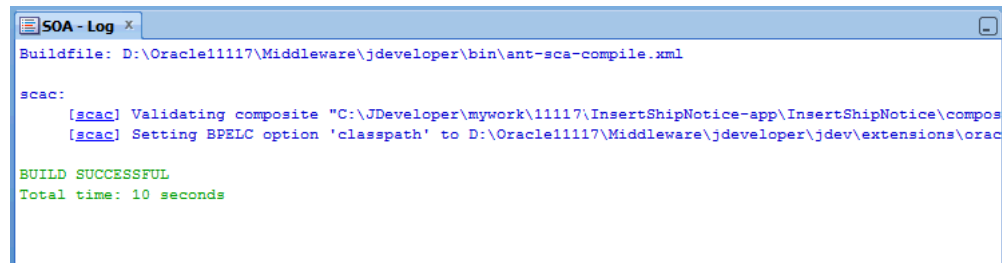

Verify that the deployment is successful in the Deployment - Log window.

## Testing the Deployed SOA Composite Application with BPEL Process

Once the BPEL process contained in a SOA Composite application is deployed, you can manage and monitor the process from the Oracle Enterprise Manager Fusion Middleware Control Console. You can also test the integration by manually initiating the process.

**To test the deployed SOA Composite application with BPEL process:**

1. Navigate to Oracle Enterprise Manager Fusion Middleware Control Console (<http://<servername>:<portnumber>/em>). The composite you deployed is displayed in the Applications Navigation tree.
2. Enter username (such as `weblogic`) and password and click **Login** to log in to a farm.

You may need to select an appropriate target instance farm if there are multiple target Oracle Enterprise Manager Fusion Middleware Control Console farms.

3. From the Farm base domain, expand the **SOA >soa-infra** to navigate through the SOA Infrastructure home page and menu to access your deployed SOA Composite applications running in the SOA Infrastructure for that managed server.

**Note:** The Farm menu always displays at the top of the navigator. As you expand the SOA folder in the navigator and click the links displayed beneath it, the SOA Infrastructure menu becomes available at the top of the page.

Click the SOA Composite application that you want to initiate (such as 'InsertShipment') from the SOA Infrastructure.

Click **Test** at the top of the page.

4. The Test Web Service page for initiating an instance appears. You can specify the XML payload data to use in the Input Arguments section.

Enter the input string required by the process and click **Test Web Service** to initiate the process.

### Testing Web Service

Name	Type	Value
* payload	payload	
* input	string	test

The test results appear in the Response tab upon completion.

5. Click the Instances tab. The SOA Composite application instance ID, name, conversation ID, most recent known state of each instance since the last data refresh of the page are displayed.

In the Instance ID column, click a specific instance ID to show the message flow through the various service components and binding components. The Flow Trace page is displayed.

In the Trace section, you should find the sequence of the message flow for the service binding component (`insertshipment_client_ep`), BPEL component (`InsertShipment`), and reference binding components (`getShippingDetails` and `InsertShipment`). All involved components have successfully received and processed messages.

If any error occurred during the test, you should find it in the Faults section.

6. Click your BPEL service component instance link (such as `InsertShipment`) to display the Instances page where you can view execution details for the BPEL activities in the Audit Trail tab.

Click the Flow tab to check the BPEL process flow diagram. Click an activity of the process diagram to view the activity details and flow of the payload through the process.

## Verifying Records in Oracle E-Business Suite

### To verify records in Oracle E-Business Suite:

1. Log in to Oracle E-Business Suite as the System Administrator.
2. Select **Requests** from the **View** menu.
3. Search for the Request by entering the Request Id that you got from the audit trail, then click **Find**.

#### Find Requests Dialog Box

Find Requests Dialog Box

My Completed Requests

My Requests In Progress

All My Requests

Specific Requests

Request ID: 2967187

Name: \_\_\_\_\_

Date Submitted: \_\_\_\_\_

Date Completed: \_\_\_\_\_

Status: \_\_\_\_\_

Phase: \_\_\_\_\_

Requestor: \_\_\_\_\_

Include Request Set Stages in Query

Order By: Request ID

Select the Number of Days to View: 7

Submit a New Request... Clear Find

4. The Request details are displayed. You can check for details such as the Phase and Status of the request.
5. If the **Status** of the request is **Complete**, you can also query the appropriate table in Oracle E-Business Suite to search for the relevant records that have been inserted.

### Querying Oracle E-Business Suite for a Record

```
SQL> select distinct(shipment_num) from rcv_headers_interface where s  
shipment_num = 'S1722427';  
  
SHIPMENT_NUM  
-----  
S1722427  
  
SQL> █
```





---

## WSDL Definition File and Connection Information Details

### WSDL Definition File

Web Service Definition Language (WSDL) is generated by the JDeveloper BPEL Designer during design time. The WSDL file generated by the Adapter Wizard is the adapter service definition. In addition, it specifies various operations exposed by the service. The operations are based on user input to the Adapter Wizard. An operation either retrieves or inserts data to Oracle Applications and is represented by a JCA activation or interaction spec.

## Example of a WSDL File

```
<?xml version="1.0" encoding="UTF-8"?>
<wsdl:definitions name="OrderImportConcurrentProgram"
  targetNamespace="http://xmlns.oracle.com/OrderImportConcurrentProgram_App/adapters_apps_101_OrderImportConcurrentProgram"
  xmlns:wsdl="http://schemas.xmlsoap.org/wsdl/"
  xmlns:client="http://xmlns.oracle.com/OrderImportConcurrentProgram_App/adapters_apps_101_OrderImportConcurrentProgram"
  xmlns:plnk="http://schemas.xmlsoap.org/ws/2003/05/partner-link"/>

  <!-- *****
  TYPE DEFINITION - List of services participating in this BPEL process
  The default output of the BPEL designer uses strings as input and
  output to the BPEL Process. But you can define or import any XML
  Schema type and use them as part of the message types.
  ***** -->
  <wsdl:types>
    <schema xmlns="http://www.w3.org/2001/XMLSchema">
      <import namespace="http://xmlns.oracle.com/OrderImportConcurrentProgram_App/adapters_apps_101_OrderImportConcurrentProgram"
        />
    </schema>
  </wsdl:types>

  <!-- *****
  MESSAGE TYPE DEFINITION - Definition of the message types used as
  part of the port type definitions
  ***** -->
  <wsdl:message name="OrderImportConcurrentProgramRequestMessage">
    <wsdl:part name="payload" element="client:process"/>
  </wsdl:message>

  <wsdl:message name="OrderImportConcurrentProgramResponseMessage">
    <wsdl:part name="payload" element="client:processResponse"/>
  </wsdl:message>

  <!-- *****
  PORT TYPE DEFINITION - A port type groups a set of operations into
  a logical service unit.
  ***** -->
  <!-- portType implemented by the OrderImportConcurrentProgram BPEL process -->
  <wsdl:portType name="OrderImportConcurrentProgram">
    <wsdl:operation name="process">
      <wsdl:input message="client:OrderImportConcurrentProgramRequestMessage"/>
    </wsdl:operation>
  </wsdl:portType>

  <!-- portType implemented by the requester of OrderImportConcurrentProgram BPEL process
  for asynchronous callback purposes
  -->
  <wsdl:portType name="OrderImportConcurrentProgramCallback">
    <wsdl:operation name="processResponse">
      <wsdl:input message="client:OrderImportConcurrentProgramResponseMessage"/>
    </wsdl:operation>
  </wsdl:portType>

  <!-- *****
  PARTNER LINK TYPE DEFINITION
  the OrderImportConcurrentProgram partnerLinkType binds the provider and
  requester portType into an asynchronous conversation.
  ***** -->
  <plnk:partnerLinkType name="OrderImportConcurrentProgram">
    <plnk:role name="OrderImportConcurrentProgramProvider">
      <plnk:portType name="client:OrderImportConcurrentProgram"/>
    </plnk:role>
    <plnk:role name="OrderImportConcurrentProgramRequester">
      <plnk:portType name="client:OrderImportConcurrentProgramCallback"/>
    </plnk:role>
  </plnk:partnerLinkType>
</wsdl:definitions>
```

## Configuring Connection Information

Oracle Adapter for Oracle Applications is deployed as JCA 1.5 resource adapter within

the Oracle WebLogic Server container.

Although Oracle Adapter for Oracle Applications is physically deployed as JCA 1.5 resource adapter, the logical deployment of the Adapter involves creating the connection entries for the JCA 1.5 resource adapter. This connection information is for tying up the database connection information provided when you create a partner link or service and is used by iAS at run time in the background.

The following example of connection configuration for Adapter for Oracle Applications can be used with the Oracle Applications adapter tutorials packaged with the product. For the logical deployment changes to take effect, the Oracle WebLogic Server container process must be restarted.

The following topics are included in this section:

- Configuring the Data Source in Oracle WebLogic Server, page A-3
- Creating Connection Factory for Adapter for Oracle Applications, page A-9
- Creating the Application Server Connection, page A-12

## Configuring the Data Source in Oracle WebLogic Server

Oracle WebLogic Server consists of a JCA container for hosting JCA resource adapters. JCA defines standard Java interfaces for simplifying the integration of a J2EE server with various back-end applications. All client applications run within the Oracle WebLogic Server environment.

The JCA resource adapter is a WebLogic Server component contained in a Resource Adapter Archive (RAR) file within the applications/directory. An RAR file contains a correctly formatted deployment descriptor. In addition, it contains declarative information about the contract between the Oracle WebLogic Server and resource adapter.

The `weblogic-ra.xml` file is the deployment descriptor for a WebLogic resource adapter. It contains deployment configurations for deploying resource adapters to Oracle WebLogic Server, which includes the back-end application connection information as specified in the deployment descriptor of the resource adapter, Java Naming and Directory Interface (JNDI) name to be used, connection pooling parameters, security identities, Work Manager properties, logging, and resource principal mapping mechanism and configurations.

**Note:** A WebLogic resource adapter also uses `ra.xml` descriptor that describes the resource adapter-related attributes type and its deployment properties using the standard XML schema specified by the JCA 1.5 Specification.

After successfully installing Oracle WebLogic Server, use the following steps to configure the data sources in the Oracle WebLogic Server Administration Console:

**Note:** How to install Oracle WebLogic Server and create connection factory, see *Oracle WebLogic Server Installation Guide* for details.

1. Navigate to `http://servername:portnumber/console`.
2. Enter the server administrator's username and password to log on to the Oracle WebLogic Server Administration Console.

The Home page of the Oracle WebLogic Server Administration Console appears.

### Oracle WebLogic Server Administration Console Home Page

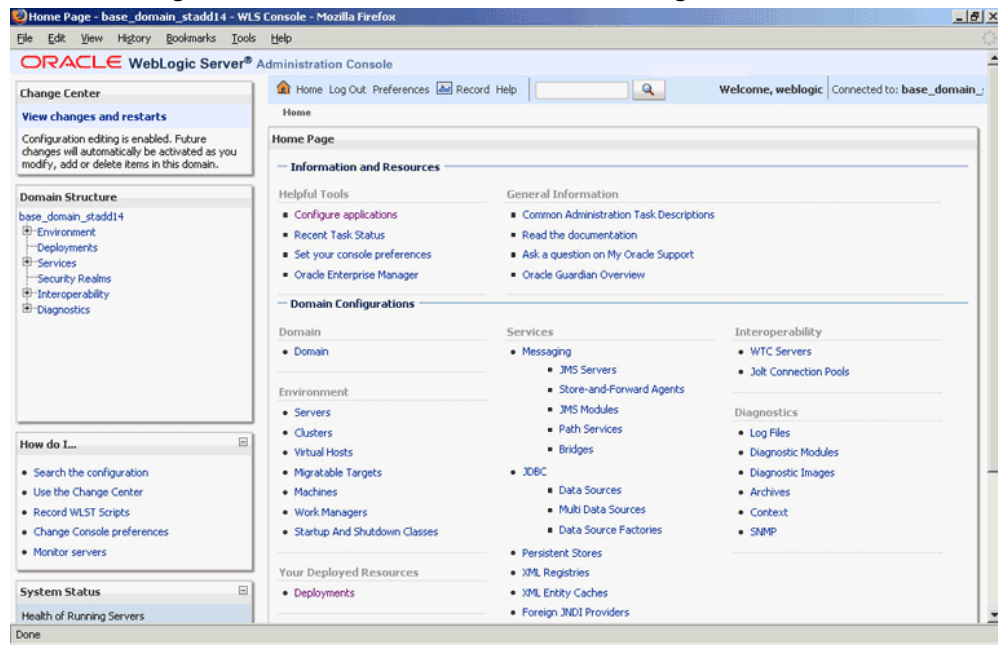

3. Under the Domain Structure section, select **Services > JDBC > DataSources**.

The Summary of JDBC Data Sources page is displayed.

## The Summary of JDBC Data Sources Page

**ORACLE WebLogic Server® Administration Console**

Home > Summary of Deployments > OracleAppsAdapter > Summary of Deployments > OracleAppsAdapter > Summary of JDBC Data Sources > Summary of Deployments > Summary of JDBC Data Sources

Welcome, weblogic | Connected to: base\_domain

**Change Center**  
View changes and restarts  
Pending changes exist. They must be activated to take effect. You may activate them now. Otherwise, they will be automatically activated when you next modify, add or delete items in this domain.

**Domain Structure**  
base\_domain  
- Environment  
- Deployments  
- Services  
- Messaging  
- JDBC  
- Data Sources  
- Multi Data Sources  
- Data Source Factories  
- Persistent Stores  
- Foreign JNDI Providers  
- Work Contexts  
- XML Registries  
- XML Entity Caches

**How do I...?**  
• Create JDBC data sources  
• Create ULR-enabled JDBC data sources

**System Status**  
Health of Running Servers

**Summary of JDBC Data Sources**  
A JDBC data source is an object bound to the JNDI tree that provides database connectivity through a pool of JDBC connections. Applications can look up a data source on the JNDI tree and then borrow a database connection from a data source.  
This page summarizes the JDBC data source objects that have been created in this domain.

[Customize this table](#)

**Data Sources (Filtered - More Columns Exist)**

Name	JNDI Name	Targets
EDNDataSource	jdbc/EDNDataSource	soa_server1
EDNLocalTxDataSource	jdbc/EDNLocalTxDataSource	soa_server1
mds-owsm	jdbc/mds/owsm	AdminServer, soa_server1
mds-soa	jdbc/mds/MDS_LocalTxDataSource	AdminServer, soa_server1
OraSDPMDDataSource	jdbc/OraSDPMDDataSource	soa_server1
SOADDataSource	jdbc/SOADDataSource	soa_server1
SOALocalTxDataSource	jdbc/SOALocalTxDataSource	soa_server1

4. In the Summary of JDBC Data Sources section, click **New** and select the option **Generic Datasource** to create a new data source. The Create a New JDBC Data Source page is displayed.
5. Enter the values for the properties to be used to identify your new JDBC data source.

## The Create a New JDBC Data Source - JDBC Data Source Properties Page

ORACLE WebLogic Server® Administration Console

Home Log Out Preferences Record Help Welcome, weblogic Connected to: base\_domain

Change Center

View changes and restarts

Domain Structure

How do I...

System Status

Health of Running Servers

Failed (0)  
Critical (0)  
Overloaded (0)  
Warning (0)  
OK (2)

Create a New JDBC Data Source

Back Next Finish Cancel

JDBC Data Source Properties

The following properties will be used to identify your new JDBC data source.  
\* Indicates required fields

What would you like to name your new JDBC data source?

\* Name: XASOADDataSource

What JNDI name would you like to assign to your new JDBC Data Source?

JNDI Name: XASOADDataSource

What database type would you like to select?

Database Type: Oracle

What database driver would you like to use to create database connections? Note: \* indicates that the driver is explicitly supported by Oracle WebLogic Server.

Database Driver: \*Oracle's Driver (Thin XA) for Instance connections: Versions:3.0.1.9.2.0,10,11

Back Next Finish Cancel

- Name: Enter a desired new JDBC data source name.
- JNDI Name: Enter a JNDI name that you like to assign to your new JDBC Data Source.
- Database Type: Select Oracle as database type from the drop-down list.
- Database Driver: Select Oracle's Driver (Oracle's Driver (Thin and ThinXA) is the only supported version).

**Note:** A driver name with '\*' indicates that the driver is explicitly supported by Oracle WebLogic Server.

6. Click **Next**. The Create a New JDBC Data Source - Transaction Options page is displayed.
7. Click **Next**. The Create a New JDBC Data Source - Connection Properties page is displayed.

## The Create a New JDBC Data Source - Connection Properties page

The screenshot displays the Oracle WebLogic Server Administration Console interface. The main window is titled "Create a New JDBC Data Source" and is divided into two sections: "Create a New JDBC Data Source" and "Connection Properties".

**Connection Properties**

Define Connection Properties.

What is the name of the database you would like to connect to?

**Database Name:**

What is the name or IP address of the database server?

**Host Name:**

What is the port on the database server used to connect to the database?

**Port:**

What database account user name do you want to use to create database connections?

**Database User Name:**

What is the database account password to use to create database connections?

**Password:**

**Confirm Password:**

Navigation buttons: Back, Next, Finish, Cancel.

8. Enter the connection properties in the Connection Properties page.
  - Database Name: Enter a database name that you would like to connect.
  - Host Name: Enter a host name or IP address of the database server.
  - Port: Enter a database port on the database server used to connect to the database.
  - Database User Name: Enter the database account username that you want to use to create the database connections.
  - Password: Enter the database account password that you want to use to create the database connections.
  - Confirm Password: Enter the same password for confirmation.
9. Click **Next**. The Create a New JDBC Data Source - Test Database Connection page is displayed.

## The Create a New JDBC Data Source - Test Database Connection Page

The screenshot shows the Oracle WebLogic Server Administration Console. The main content area is titled 'Create a New JDBC Data Source' and contains a 'Test Database Connection' section. The 'Test Database Connection' section includes a 'Test Configuration' button and a 'Test Database Connection' button. Below this, there are several text boxes for configuration: 'Driver Class Name' (oracle.jdbc.xe.client.OracleDriver), 'URL' (jdbc:oracle:thin:@dbhost:1521:xe), 'Database User Name' (apps), and 'Password' (masked). There is also a 'Confirm Password' field. The left sidebar shows the 'Domain Structure' tree with 'base\_domain' selected, and 'Services' > 'JDBC' > 'Data Sources' selected. The 'How do I...' section has 'Create JDBC data sources' selected. The 'System Status' section shows 'Health of Running Servers' with 'OK (2)'.

10. Click **Test Configuration** to test the database availability and the connection properties you provided.

A 'Connection test succeeded' message appears at the top of the Create a New JDBC Data Source - Test Database Connection page.

11. Click **Next**. The Create a New JDBC Data Source - Select Targets page is displayed.

## The Create a New JDBC Data Source - Select Targets Page

The screenshot shows the Oracle WebLogic Server Administration Console. The main content area is titled 'Create a New JDBC Data Source' and contains a 'Select Targets' section. The 'Select Targets' section includes a 'Select Targets' button and a 'Servers' table. The 'Servers' table has two rows: 'AdminServer' and 'soa\_server1'. The 'soa\_server1' row has a checked checkbox. Below the table are 'Back', 'Next', 'Finish', and 'Cancel' buttons. The left sidebar shows the 'Domain Structure' tree with 'base\_domain' selected, and 'Services' > 'JDBC' > 'Data Sources' selected. The 'How do I...' section has 'Create JDBC data sources' selected. The 'System Status' section shows 'Health of Running Servers' with 'OK (2)'.

12. Select the 'soa\_server1' check box, and then click **Finish**.

The Summary of JDBC Data Sources page is displayed. This page summarizes the JDBC data source objects that have been created in this domain. The Data Source that you created appears in this list.



## Creating Connection Factory for Adapter for Oracle Applications

The deployment descriptor of the Adapter for Oracle Applications must associate with the Java Naming and Directory Interface (JNDI) name with configuration properties required by the adapter to access the database.

Use the following steps to configure the JNDI and additional settings for Adapter for Oracle Applications through the Oracle WebLogic Server Administration Console:

1. Navigate to `http://servername:portnumber/console`.
2. Enter the server administrator's username and password to log on to the Oracle WebLogic Server Administration Console.

The Home page of the Oracle WebLogic Server Administration Console appears.

3. Under the Domain Structure section, select **Deployment**.

The Summary of Deployments page appears where you can find a list of Java EE applications and standalone application modules that have been installed to this domain.

4. Locate an appropriate link for Oracle Adapter for Oracle Applications from the summary of deployment table first and then click the link.

## Summary of Deployments

**Summary of Deployments**

This page displays a list of Java EE applications and stand-alone application modules that have been installed to this domain. Installed applications and modules can be started, stopped, updated (redeployed), or deleted from the domain by first selecting the application name and using the controls on this page.

To install a new application or module for deployment to targets in this domain, click the Install button.

**Customize this table**

**Deployments**

Name	State	Health	Type	Deployment Order
oracle.soa.mediator(11.1.1,11.1.1)	Active		Library	304
oracle.soa.rules_editor_dc.webapp(11.1.1,11.1.1)	Active		Library	306
oracle.soa.workflow(11.1.1,11.1.1)	Active		Library	303
oracle.soa.worklist(11.1.1,11.1.1)	Active		Library	302
oracle.webcenter.composer(11.1.1,11.1.1)	Active		Library	300
oracle.wsm.seedpolicies(11.1.1,11.1.1)	Active		Library	100
OracleAppsAdapter	Active	OK	Resource Adapter	328
OracleBamAdapter	Active	OK	Resource Adapter	329
OrderApprovalHumanTask	Active	OK	Enterprise Application	100
soa-infra	Active	OK	Enterprise Application	311

The Overview Settings for the selected application name appears.

- Click the **Configuration** tab and the **Outbound Connection Pools** subtab to display the Outbound Connection Pool groups and instances for this selected resource adapter.

## Outbound Connection Pool Configuration Table

**Settings for OracleAppsAdapter**

**Outbound Connection Pools**

This page displays a table of Outbound Connection Pool groups and instances for this resource adapter. The top level entries in the table represent Outbound Connection Pool groups. Groups are listed by connection factory interface and the instances are listed by their JNDI names. Expand a group to obtain configuration information for a Connection Pool instance within an Outbound Connection Pool group. Click the name of a group or instance to configure it. Automatically generated Connection Pools are not displayed in the table below.

**Outbound Connection Pool Configuration Table**

Groups and Instances	Connection Factory Interface
javax.resource.cci.ConnectionFactory	javax.resource.cci.ConnectionFactory

You can click the `javax.resource.cci.ConnectionFactory` link to expand this group and obtain configuration information for a Connection Pool instance.

- Click **New** and select the `javax.resource.cci.ConnectionFactory` radio button to create an instance. Click **Next** to create a new outbound connection.

7. Enter a JNDI name that you want to use to obtain the new connection instance. For example, enter `eis/Apps/Apps`.

### Create a New Outbound Connection

The screenshot shows the Oracle WebLogic Server Administration Console interface. The main window displays the 'Create a New Outbound Connection' wizard. The breadcrumb navigation shows 'Home > Summary of Deployments > OracleAppsAdapter'. The wizard has a progress bar and navigation buttons: 'Back', 'Next', 'Finish', and 'Cancel'. The current step is 'JNDI name for Outbound Connection Instance', which prompts the user to 'Enter the JNDI name that you want to use to obtain the new connection instance'. A note indicates that asterisks (\*) denote required fields. Below the prompt, there is a text input field containing the value 'eis/Apps/Apps'. The wizard also includes a brief description: 'The Outbound Connection instance represents a connection pool. The JNDI name can be used to obtain the pool at runtime.'

The Outbound Connection instance represents a connection pool. The JNDI name can be used to obtain the pool at run time.

Click **Finish**.

8. This opens the Save Deployment Plan Assistant page where you can find the new deployment plan information including plan path with an XML extension (`.xml`), recently used paths, and current location.

**Note:** The plan path must have an XML extension (`.xml`). It is recommended that this file be called `Plan.xml`, and that each plan be located in a unique directory. If the plan file exists it will be overwritten. Other files in the plan directory may be overwritten as well.

9. Click **OK** to save the configuration change for a deployment plan.

You may find some unexpected exception messages populated while processing the request. Use the following steps to resolve the issue:

1. Click the Adapter link that you selected earlier on the breadcrumb navigation path.
2. Click the **Configuration** tab and the **Outbound Connection Pools** subtab to display the Outbound Connection Pool groups and instances.

Click the `javax.resource.cci.ConnectionFactory` expand node to display the newly configured JNDI (such as `eis/Apps/Apps`) for the outbound instance in the configuration table.

3. Click the outbound instance name (such as `eis/Apps/Apps`) to display the outbound connection properties.

## Outbound Connection Properties Page

ORACLE WebLogic Server® Administration Console

Welcome, weblogic Connected to: base\_domain

Home > Summary of Deployments > OracleAppsAdapter > Summary of Deployments > OracleAppsAdapter > Summary of JDBC Data Sources > Summary of Deployments > Summary of JDBC Data Sources > base\_domain > Summary of JDBC Data Sources

Settings for javax.resource.cci.ConnectionFactory

General Properties Transaction Authentication Connection Pool Logging

This page allows you to view and modify the configuration properties of this outbound connection pool. Properties you modify here are saved to a deployment plan.

Outbound Connection Properties

Property Name	Property Type	Property Value
dataSourceName	java.lang.String	
xADDataSourceName	java.lang.String	

- Place your mouse in the Property Value column for the 'xADDataSourceName' property name and click to enable the input text box.

Enter xADDataSourceName in the text box, press [Enter] key, and then click Save to update the deployment plan.

The Summary of JDBC Data Source page appears with xADDataSourceName listed in the table.

## Outbound Connection Properties Page

ORACLE WebLogic Server® Administration Console

Welcome, weblogic Connected to: base\_domain

Home > Summary of Deployments > OracleAppsAdapter > Summary of Deployments > OracleAppsAdapter > Summary of JDBC Data Sources > Summary of Deployments > Summary of JDBC Data Sources > base\_domain > Summary of JDBC Data Sources

Settings for javax.resource.cci.ConnectionFactory

General Properties Transaction Authentication Connection Pool Logging

This page allows you to view and modify the configuration properties of this outbound connection pool. Properties you modify here are saved to a deployment plan.

Outbound Connection Properties

Property Name	Property Type	Property Value
dataSourceName	java.lang.String	
xADDataSourceName	java.lang.String	xADDataSourceName

- Select 'OracleAppsAdapter' from Deployments and click **Update** to complete the update wizard. The new Connection Factory settings would be applied without restarting.

## Creating the Application Server Connection

You must establish a connectivity between the design-time environment and the server you want to deploy it to. In order to establish such a connectivity, you must create the application server connection.

Use the following steps to create the application server connection:

1. From Oracle JDeveloper, select **View >Application Server Navigator** to open the Application Server tab.

**Create a New Application Server Connection**

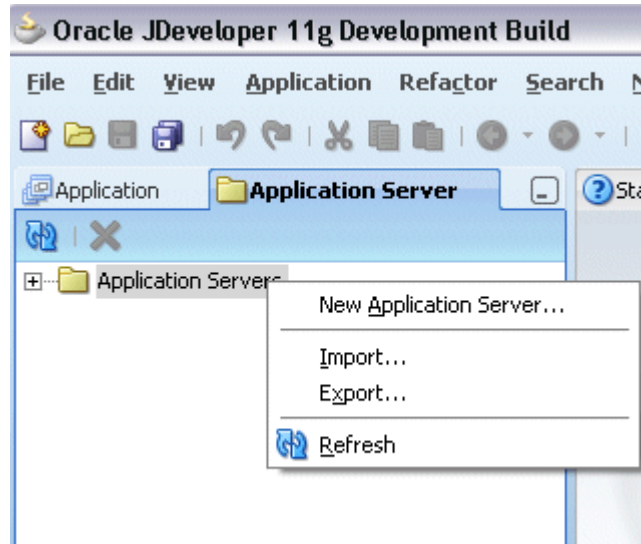

2. Right-click on the Application Server and select **New Application Server** to open the Create Application Server Connection wizard.
3. Enter the connection name and select **WebLogic 10.3** as the connection type. Click **Next**.

### Select the Server Name and Type

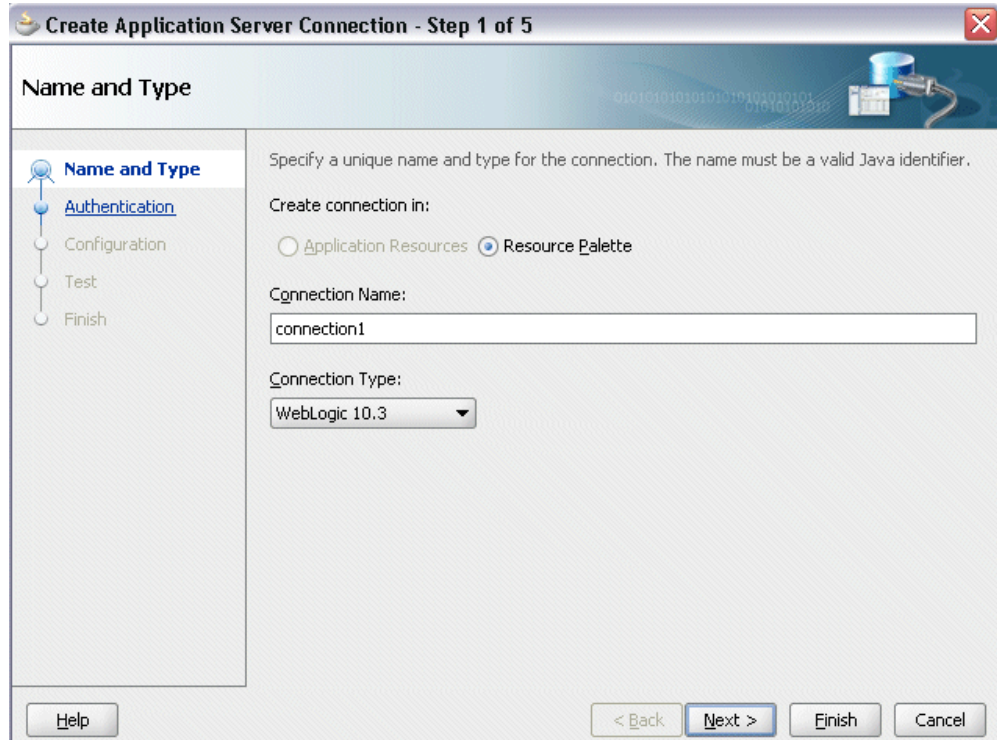

4. Enter the username (such as `weblogic`) and password specified during installation and click **Next**.

### Enter Server Authentication Information

**Create Application Server Connection - Step 2 of 5**

#### Authentication

Specify a username and password to authenticate the connection.

Username:

Password:

Help < Back Next > Finish Cancel

5. Enter the WebLogic Server connection host name and port information. Leave the default domain name unchanged in the WLS Domain field.

Click **Next**.

### Specifying Server Configuration Information

**Create Application Server Connection - Step 3 of 5**

#### Configuration

WebLogic Server connections use a host name and port to establish a connection. The Domain of the target will be verified

Weblogic Hostname (Administration Server):  
localhost

Port: 7001      SSL Port: 7002

Always use SSL

WLS Domain:  
wl\_server

Help      < Back      Next >      Finish      Cancel

6. Click **Test Connection** to validate your server configuration. You should find success messages populated in the Status window.



## Validating the Server Configuration

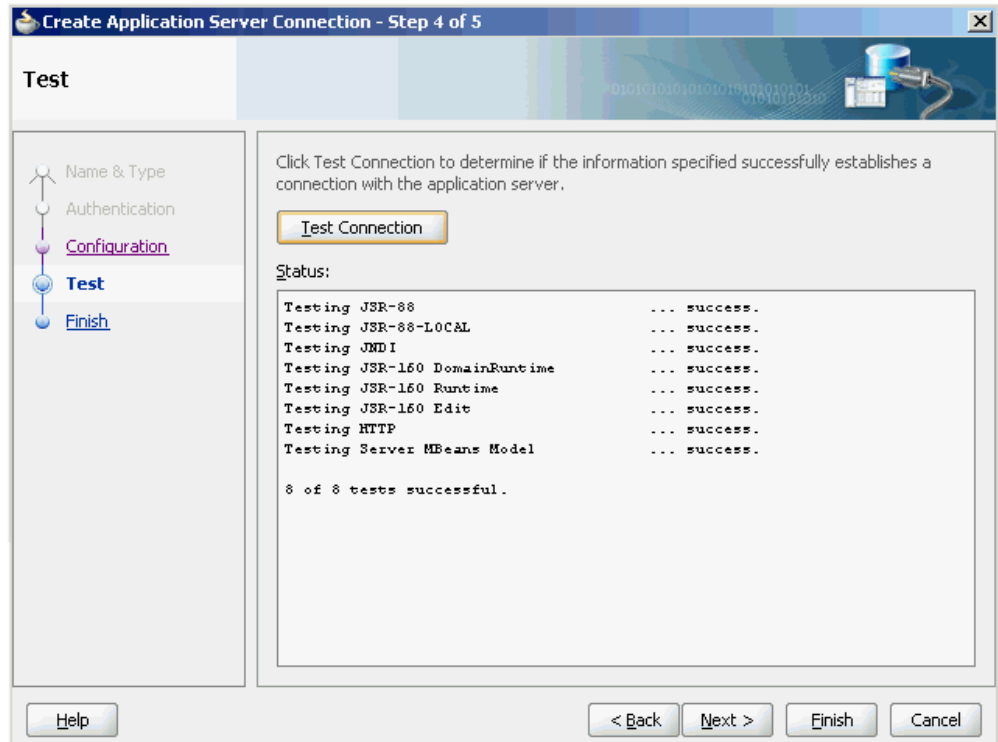

Click **Finish**.



---

## Troubleshooting and Workarounds

### General Issues and Workarounds

This section describes the following issues and workarounds:

- **Sequence of Elements in XML and XSD Files Should Match**

From this release (11.1.1.7.0), order of elements passed as input to an API using Adapter for Oracle Applications should strictly be the same as the order in which those elements appear under the `sequence` tag of the corresponding schema.

Please note that in previous releases, Adapter for Oracle Applications was non-restrictive and these elements could be passed in any order. However, the sequence of elements should now match the sequence in the corresponding schema.

- **Support for Business Events through Existing Partner Links**

With the additional support for business event groups, perform the following steps to modify all existing partner links for outbound business events contained in an event group that is being listened to:

**Important:** This workaround is applicable only if Adapter for Oracle Applications is being used for listening to Event Groups. It is NOT needed if the Business Event is not part of any Event Group that is being listened to.

1. Updating the JCA property "MessageSelectorRule" for the existing Business Event partner links. This can be achieved by performing either one of the following steps:

- Rerunning the Adapter Configuration (Recommended)

Rerunning or editing the configuration wizard for an existing partner link of an outbound business event (on Oracle JDeveloper 11.1.1.6.0 and above)

would update the artifacts with the appropriate MessageSelectorRule.

- Manually Updating the JCA Properties

Alternatively, modify the JCA property "MessageSelectorRule" for the business event partner link located in the file `XXX_apps.jca`, as stated below:

**Note:** `<EVENT_NAME>` is to be replaced with the name of the Business Event.

Change existing property from:

```
<property name="MessageSelectorRule"
value="tab.user_data.event_name = '<EVENT_NAME>'"/>
```

To the following:

```
<property name="MessageSelectorRule"
value="tab.user_data.event_name = '<EVENT_NAME>' AND
tab.user_data.getvalueforparameter('GROUP') IS NULL"/>
```

2. Delete the existing subscriber on WF\_BPEL\_Q of the corresponding Oracle Applications.
  1. Undeploy the SOA Composite application containing the Business Event partner link.
  2. Delete the subscriber using the following snippet:

**Note:** `<CONSUMER_NAME>` is to be replaced with the name of the subscriber. It can be found in the `XXX_apps.jca` file as the value for the JCA property 'Consumer'.

```
begin
subscriber := sys.aq$_agent('<CONSUMER_NAME>', NULL, NULL);
dbms_aqadm.remove_subscriber(queue_name => 'WF_BPEL_Q',
subscriber => subscriber);
end;
```

3. Redeploy the SOA Composite application.

For more information about business event groups, see Business Event Groups, page 6-3.

- **"DataSecurityCheck" Requires "IRepOverloadSeq" to be Passed for Overloaded Functions**

Adapter for Oracle Applications uses the following two new JCA properties to handle access control for overloaded PL/SQL APIs. This feature works in

conjunction with the grants created from the Integration Repository user interface, and it does not depend on any profile options.

- DataSecurityCheck
- IRepOverloadSeq

If a user wants the Function Security Authorization check to be performed, the following property information needs to be added in the WSDL file (XX\_apps.jca):

```
<property name="DataSecurityCheck" value="yes"/>
```

However, the other property IRepOverloadSeq is derived automatically by Adapter for Oracle Applications at the design time during creation of the partner link. Based on these two properties, the function security check would be performed for the username, which is passed as a header property.

Please note that this security support would work with all interfaces which are available in the Integration Repository. For other interfaces, you need to enable the function security through the profile option "EBS Adapter for BPEL, Function Security Enabled" (EBS\_ADAPTER\_FUNCTION\_SEC\_ENABLED).

For more information about security support for overloaded functions, see Function Security Support for Overloaded Functions, page 4-15.

- **Populating Default Values for Record Types While Using PL/SQL APIs**

Certain PL/SQL APIs exposed from Oracle E-Business Suite take record types as input. Such APIs expect default values to be populated for parameters within these record types for successful execution.

The default values are FND\_API.G\_MISS\_CHAR for characters, FND\_API.G\_MISS\_DATE for dates, and FND\_API.G\_MISS\_NUM for numbers. Oracle Adapter for Oracle Applications can default these values when the parameters within the record type are passed as nil values, for example, as shown below:

```
<PRICE_LIST_REC>  
<ATTRIBUTE1 xsi:nil="true"/>  
<ATTRIBUTE2 xsi:nil="true"/>  
<ATTRIBUTE3 xsi:nil="true"/>  
...  
</PRICE_LIST_REC>
```

This can be achieved with the help of a function in a Transform activity, or by directly passing the XML input with nil values and then assigning them to the record types within an Assign activity.

- **Recreating Wrapper Packages While Using Existing PL/SQL SOA Composites Against a Different Release Instance**

When a user has a SOA composite of a PL/SQL API created against an Oracle E-Business Suite Release 11i instance and intends to use it against the Release 12

instance or vice versa, for the compatibility in the target instance, the wrapper package of the SOA composite must be recreated. This approach updates the signature in the generated wrapper SQL file for the target instance and avoids the possible confusion whether the signature is the same or has changed in the target instance.

- **WSDL Context Information Default Values**

Applications context is used in passing header variables that may be required in a business activity or to complete a BPEL process. When setting the context, it takes into account the values passed for the header properties including *Username*, *Responsibility*, *Responsibility Application*, *Security Group*, and *NLS Language*.

If the values for the new header properties *Responsibility Application*, *Security Group*, and *NLS Language* are not passed, context information will be determined based on *Username* and *Responsibility*.

The default Username is SYSADMIN, the default Responsibility is SYSTEM ADMINISTRATOR, the default Security Group Key is Standard, and the default NLS Language is US.

You can change the default values specified in the generated WSDL. This is a static way of changing the context information. These values would apply to all invocations of the deployed business process. However, if you need to provide different context information for different invocations of the business process, then you can dynamically populate the header values. The context information can be specified by configuring an Invoke activity.

For more information about applications context, see Supporting for Normalized Message Properties, page 4-7.

- **Correlation ID Defaults to BPEL for XML Gateway Transactions**

The Adapter Configuration wizard of Oracle Adapter for Oracle Applications does not specify a correlation ID for XML Gateway transactions for inbound or outbound interfaces. Instead, a default correlation ID of BPEL is automatically set in the WSDL file. To make this configuration work, you must configure Oracle Applications to set the same correlation ID value of BPEL for the corresponding XML Gateway transactions.

If you want the Adapter to use a different correlation ID than the default, you need to configure a correlation ID in Oracle Applications, then edit the `Correlation="BPEL"` line contained in the `<jca:operation>` section of the adapter service WSDL. Replace BPEL with the string value of the correlation ID you specified in Oracle Applications.

- **Workaround for Stored Procedures Using Complex Types and the DEFAULT Clause**

When working with stored procedures for which the Adapter Configuration wizard must generate wrapper SQL stored procedures, there is a current limitation on

DEFAULT clauses not being carried over to the generated wrapper stored procedures.

As a workaround, perform the following steps one time only for a given stored procedure:

1. Open the generated wrapper SQL script.
2. Copy all default clauses from the base-stored procedure into the corresponding wrapper.
3. Use SQL\*Plus to reload the wrapper SQL script into the database.
4. Edit the generated XSD. If a parameter has a DEFAULT clause, its corresponding element in the XSD must have the extra attribute: `db:default="true"`

For example, with the following SQL:

```
FINANCE$INVOICE(isTrue INTEGER DEFAULT 1, value NUMBER DEFAULT 0)
```

The elements in the XSD for `isTrue` and `value` must have the new attribute:

```
<element name="ISTRUE" ... db:default="true" .../>
<element name="VALUE" ... db:default="true" .../>
```

- **Cannot Create a Partner Link If the Underlying API Has Been Recreated**

The generation of a wrapper for an API that was recreated with the same name, but with a different set of parameters, will fail.

**Note:** This can happen for both packaged procedures and top-level or root procedures that require generated wrappers.

The following example illustrates the problem:

1. Create the initial API that, in this case, is defined at the top level:

```
SQL> create procedure test (a number, b varchar2, c BOOLEAN)
```

The `BOOLEAN` parameter indicates that a wrapper is necessary.

2. Use the database adapter for stored procedures in the Adapter Configuration Wizard to generate and load the wrapper for this API.
3. Drop the API, then recreate it with a different set of parameters:

```
SQL> drop procedure test
SQL> create procedure test (a number, b varchar2, c number, d
BOOLEAN)
```

4. An attempt to generate a partner link for this API using the Adapter Configuration Wizard will fail with the following message:

The wrapper procedure, `TOPLEVEL$TEST`, could not be found

5. As a workaround, exit JDeveloper BPEL Designer and restart it after recreating the stored procedure, but before attempting to create the second partner link.



---

# Adapter for Oracle Applications Properties

## Overview

This appendix describes the properties applicable to the Adapter for Oracle Applications, including:

- JCA Properties for Adapter for Oracle Applications, page C-1
- JCA Properties for Adapter for Oracle Applications: Normalized Properties, page C-4
- Binding Properties for Adapter for Oracle Applications, page C-7

For more information about JCA properties, see:

- Section A.7, Generic Oracle JCA Adapter Properties, *Oracle Fusion Middleware User's Guide for Technology Adapters* for properties applicable to all Oracle JCA Adapters
- Section 33.1.2.8, Oracle JCA Adapters Endpoint Properties, *Oracle Fusion Middleware Administrator's Guide for Oracle SOA Suite and Oracle Business Process Management Suite*
- Appendix H, Normalized Message Properties, *Oracle Fusion Middleware Developer's Guide for Oracle SOA Suite*

## JCA Properties for Adapter for Oracle Applications

The following table lists the JCA properties used for Adapter for Oracle Applications:

Property	Description
SchemaName	The schema of the Oracle E-Business Suite. Usually points to the "Apps" or Apps-equivalent schema.
PackageName	Name of the PL/SQL package or the wrapper package.
ProcedureName	Name of the procedure or function to be invoked. Points to Wrapper procedure / function if present.
DataSecurityCheck	Passing this property with a value of "yes" enables function security check for PL/SQL APIs and Concurrent Programs.
QueryTimeout	This property specifies the maximum number of seconds that the JDBC driver should wait for the specified stored procedure or function to execute. When the threshold is exceeded, SQLException is thrown. If the value is zero, then the driver waits indefinitely.
APIErrorHandler	Passing this property enables the caller to retrieve error messages from FND_MSG_PUB message stack, without the need for another explicit call to retrieve them.
GetActiveUnitOfWork	<p>If it is set to "true", this advanced setting forces all invoked activities in the same global transaction to use the same SQL connection if going to the same database. This guarantees that later invoked activities can see the changes of earlier invoked activities.</p> <p>(However, this may not be needed if using emulated two-phase commit, which automatically uses the same connection.)</p>

Property	Description
IRepOverloadSeq	<p>This is automatically populated and is not user-configurable. It works in conjunction with "DataSecurityCheck" property.</p> <p><b>Note:</b> This property should not be altered by end users and modification might lead to undesirable results.</p>
IRepInternalName	<p>Holds an internal value used by Adapter for Oracle Applications.</p> <p><b>Note:</b> This property should not be altered by end users and modification might lead to undesirable results.</p>

The following JCA properties are specific to Enqueue and Dequeue operations that are applicable for XML Gateway and Business Event Outbound interfaces:

Property	Description
QueueName	The name of the AQ Queue being read from or written to.
DatabaseSchema	The schema of the Oracle E-Business Suite. Usually points to the "Apps" or Apps-equivalent schema.
Consumer	Name of the AQ Consumer, which dequeues the messages from the AQ Queue.
MessageSelectorRule	<p>Specifies the condition based on payload or queue header values, to screen the messages and accept only those that meet the condition.</p> <p><b>Note:</b> This property should not be altered by end users and modification might lead to undesirable results.</p>

Property	Description
AppsEventSchema	<p>Passing one of the following event schema selection options to be used for the business event payload:</p> <ul style="list-style-type: none"> <li>• No Schema</li> <li>• Any Schema</li> <li>• Specify Schema</li> </ul> <p>For information on each schema selection option, see <i>Specifying Event Schema</i>, page 6-18.</p>

## JCA Properties for Adapter for Oracle Applications: Normalized Properties

The following table lists the normalized message properties used for Adapter for Oracle Applications:

Property	Description
<code>jca.apps.Username</code>	This property specifies the Oracle E-Business Suite application username information. In the case of a null or empty value, the default Username is <code>SYSADMIN</code> ,
<code>jca.apps.Responsibility</code>	This property specifies the Oracle E-Business Suite application responsibility information for setting applications context. The default Responsibility is <code>System Administrator</code> .
<code>jca.apps.ORG_ID</code>	This property specifies the organization ID used in Oracle E-Business Suite application.
<code>jca.apps.RespApplication</code>	This property specifies the responsibility application short name information for setting applications context. It accepts Application Short Name (such as <code>FND</code> ) as its value.

Property	Description
jca.apps.SecurityGroup	This property specifies the security group information for setting applications context. The default Security Group Key is <code>Standard</code> ,
jca.apps.NLSLanguage	This property specifies the NLS language information. The default NLS Language is <code>US</code> .  It is used for multiple language support (MLS) feature for Oracle E-Business Suite.
jca.apps.ecx.TransactionType	This property specifies External Transaction Type for the business document from the Trading Partner table. The transaction type for an inbound XML document must be the same as the transaction type defined in the Trading Partner form.  This property sets XML Gateway message header information required for XML Gateway inbound transactions.
jca.apps.ecx.TransactionSubtype	This property specifies External Transaction Subtype for the business document from the Trading Partner table. The transaction subtype for an inbound XML document must be the same as the transaction subtype defined in the Trading Partner form.  Similar to <code>jca.apps.ecx.TransactionType</code> , this property sets XML Gateway message header for XML Gateway inbound transactions
jca.apps.ecx.PartySiteId	This property specifies the party site identifier for an inbound XML document. The party site must be the same as the Source Trading Partner location defined in the Trading Partner form.  This property is used to set XML Gateway message header.
jca.apps.ecx.MessageType	This property sets XML Gateway message header for payload message format. This defaults to <code>XML</code> .

Property	Description
jca.apps.ecx.MessageStandard	<p>This property sets XML Gateway message standard.</p> <p>Message format standard as displayed in the Define Transactions form and entered in the Define XML Standards form. This defaults to OAG. The message standard entered for an inbound XML document must be the same as the message standard in the trading partner setup.</p>
jca.apps.ecx.DocumentNumber	<p>This property sets document number for XML Gateway.</p> <p>The document identifier used to identify the transaction, such as a purchase order or invoice number.</p>
jca.apps.ecx.ProtocolType	<p>This property specifies the protocol type for setting XML Gateway message header.</p>
jca.apps.ecx.ProtocolAddress	<p>This property specifies the protocol address for setting XML Gateway message header.</p>
jca.apps.ecx.Username	<p>This property specifies the username for setting XML Gateway message header. USERNAME is defined in the Trading Partner table.</p>
jca.apps.ecx.Password	<p>This property specifies the password associated with the USERNAME that is defined in the Trading Partner table.</p>
jca.apps.ecx.Attribute1	<p>This property specifies the Attribute1 parameter that may be defined by the base application.</p>
jca.apps.ecx.Attribute2	<p>This property specifies the Attribute2 parameter that may be defined by the base application.</p>

Property	Description
<code>jca.apps.ecx.Attribute3</code>	<p>This property specifies the Attribute3 parameter.</p> <p>For outbound messages, this parameter has the value from the Destination Trading Partner Location Code in the Trading Partner table. For inbound messages, the presence of this value generates another XML message that is sent to the trading partner identified in the Destination Trading Partner Location Code in the Trading Partner table. This value must be recognized by the hub to forward the XML message to the final recipient of the XML Message.</p> <p>For more information, see Destination Trading Partner Location Code, <i>Oracle XML Gateway User's Guide</i>.</p>
<code>jca.apps.ecx.Attribute4</code>	<p>This property specifies the Attribute4 parameter that may be defined by the base application.</p>
<code>jca.apps.ecx.Attribute5</code>	<p>This property specifies the Attribute5 parameter that may be defined by the base application.</p>
<code>jca.apps.ecx.Payload</code>	<p>This property specifies the payload information for XML Gateway transactions.</p>

## Binding Properties for Adapter for Oracle Applications

The following table lists the binding properties used for Adapter for Oracle Applications:

Property	Description
<code>DequeueTimeout</code>	<p>It is the interval after which the dequeue() API will time out if no message is received on the inbound queue. The default value is 1s.</p>

---

<b>Property</b>	<b>Description</b>
ConnectionRetryDelay	The time for which the Adapter for Oracle Applications will wait before trying to recreate a connection after a connection is lost. The default value is 15s

---



---

# Index

## A

---

- Adapter for Oracle Applications
  - architecture, 2-3
  - features, 2-2
  - Flexfield Support Overview, 4-21
  - High Availability, 3-7
  - installing, 2-4
  - integration with BPEL PM, 2-4
  - integration with Oracle WebLogic Server, 2-6
  - interfaces, 3-1
  - issues and workarounds, B-1
  - Oracle E-Business Suite Support, 3-4
  - Oracle Integration Repository, 3-3
  - overview, 2-1
- Adapter for Oracle Applications Concepts
  - Applications Context, 4-1
  - Error and Exception Handling, 4-96
  - Function Security, 4-14
  - Module Browser, 4-98
  - overview, 4-1
  - Using J2EE Data Source, 4-97
- Adapter for Oracle Applications Properties
  - Binding Properties, C-7
  - JCA properties, C-1
  - Normalized Properties, C-4
- agent
  - See* business events concepts
- APIs
  - See* PL/SQL APIs
- applications context
  - example, 4-2

## Applications Context

- Design-Time Tasks, 4-8
- Multiple Language Support, 4-12
- multiple organization access control (MOAC), 4-11
- Normalized Message Properties, 4-7

## B

---

- B2B, 5-2
- base tables, 8-2
- business events, 6-1
  - troubleshooting, 6-47
- business events concepts, 6-2
  - agent, 6-3
  - deferred subscription processing, 6-3
  - event, 6-2
  - event activity, 6-3
  - event data, 6-3
  - Event Groups, 6-3
  - event key, 6-2
  - event message, 6-3
  - event subscription, 6-3
- business events outbound
  - Assign activity, 6-32
  - configuring Adapter for Oracle Applications, 6-4
  - creating a new SOA Composite application, 6-6
  - creating a partner link, 6-10
  - deploying the SOA Composite application, 6-36
  - design-time prerequisites, 6-5

- design-time tasks, 6-4
- file adapter partner link, 6-23
- Invoke activity, 6-30
- Receive activity, 6-21
- run-time tasks, 6-35
- testing the SOA Composite application , 6-39

## C

---

- concurrent program
  - adding a new partner link for file adapter, 7-31
- concurrent programs
  - adding a partner link, 7-9
  - configuring Adapter for Oracle Applications, 7-3
  - configuring the Assign activity, 7-49
  - configuring the Invoke activity, 7-42
  - creating a new SOA Composite application, 7-4
  - deploying the SOA Composite application, 7-54
  - design-time steps, 7-3
  - overview, 7-1
  - prerequisite to configure, 7-3
  - run-time steps, 7-54
  - testing the SOA Composite application, 7-59
  - troubleshooting, 7-63
  - verifying records, 7-62
- configure flexfields at design time
  - configure a new custom mapping, 4-29
  - importing a flexfield mapping, 4-73
  - modifying flexfield mapping, 4-77
  - review flexfield configuration, 4-80
- connection information, A-2
  - Applications Database Connection, A-9
  - data source configuration, A-3
  - WebLogic Server Connection, A-12

## D

---

- deferred subscription processing, 6-3
  - See also* business events concepts
- design-time tasks
  - business events outbound, 6-4

## E

---

## EDI

- adding a new partner link for file adapter, 10-15
- adding a partner link, 10-8
- configuring Adapter for Oracle Applications, 10-2
- configuring the Assign activity, 10-25
- configuring the Invoke activity, 10-20
- creating a new SOA Composite application, 10-3
- deploying the SOA Composite application, 10-28
- design-time steps, 10-2
- overview, 10-1
- prerequisites to configuring Adapter for Oracle Applications, 10-2
- run-time steps, 10-28
- testing the SOA Composite application, 10-33
- verifying records in Oracle Applications, 10-36

### Errors and Exceptions Handling

- Enabling Function Error Handling at Design Time, 4-97

### event

- See* business events concepts

### event activity, 6-3

- event data, 6-3
- event key, 6-2
- event message, 6-3
- event subscription, 6-3
- example WSDL file, A-1

## F

---

### Features, 3-1

### flexfield Support

- configure flexfields
  - Key Flexfields, 4-31
- configure flexfields at design time
  - Descriptive Flexfields, 4-52
- configure flexfields at design time overview, 4-27

### Flexfield Support

- key elements, 4-23

## I

---

- integration architecture, 5-2
- interface tables, 8-2

- adding a file adapter partner link, 8-23
- adding a partner link, 8-7
- configuring Adapter for Oracle Applications, 8-3
- configuring the Assign activity, 8-30
- configuring the Invoke activity, 8-27
- creating a new SOA Composite application, 8-3
- deploying the SOA Composite application, 8-33
- design-time steps, 8-3
- overview, 8-2
- prerequisites to configure, 8-3
- run-time steps, 8-32
- testing the SOA Composite application, 8-36

## **J**

---

### JCA Properties

- Overview, C-1

## **L**

---

### Logging

- Correlating Messages, 4-94
- enabling logging, 4-82
- overview, 4-81
- Searching and Viewing Logs, 4-88

## **M**

---

### message queues, 5-3

- inbound queues, 5-3
- outbound queues, 5-4

## **P**

---

### PL/SQL APIs

- adding a new partner link, 9-8
- adding a new partner link for file adapter, 9-20
- configuring Adapter for Oracle Applications, 9-2
- configuring the Assign activity, 9-39
- configuring the Invoke activity, 9-32
- configuring the Transform activity, 9-36
- creating a new SOA Composite application, 9-4
- deploying the SOA Composite application, 9-

44

- design-time steps, 9-2

- overview, 9-1

- prerequisite to configure, 9-2

- run-time steps, 9-44

- testing the SOA Composite application, 9-49

- troubleshooting, 9-53

- prerequisites

- business events outbound, 6-5

## **R**

---

- run-time tasks

- business events outbound, 6-35

## **S**

---

- standards-based messaging, 5-2

## **V**

---

- views, 8-2

- adding a new partner link for file adapter, 8-59

- adding a partner link, 8-45

- configuring Oracles Adapter for Oracle Applications, 8-39

- configuring the Assign activity, 8-69

- configuring the Invoke activity, 8-65

- creating a new SOA Composite application, 8-40

- deploying the SOA Composite application, 8-72

- design-time steps, 8-39

- overview, 8-2

- prerequisites to configure, 8-39

- run-time steps, 8-72

- testing the SOA Composite application, 8-77

## **W**

---

- wrapper APIs, 9-26

- DEFAULT clause handling in wrapper procedures, 9-31

- describing parameters with DEFAULT clause, 9-29

- WSDL, A-1

## **X**

---

- XML Gateway
  - overview, 5-2
  - troubleshooting, 5-79
- XML gateway envelope, 5-4
  - ATTRIBUTE3, 5-5
  - DOCUMENT\_NUMBER, 5-5
  - MESSAGE\_STANDARD, 5-4
  - MESSAGE\_TYPE, 5-4
  - parameters defined by the application, 5-6
  - parameters not used, 5-6
  - PARTY\_SITE\_ID, 5-5
  - PASSWORD, 5-5
  - PAYLOAD, 5-6
  - PROTOCOL\_ADDRESS, 5-5
  - PROTOCOL\_TYPE, 5-5
  - TRANSACTION\_SUBTYPE, 5-5
  - TRANSACTION\_TYPE, 5-4
  - USERNAME, 5-5
- XML gateway inbound
  - adding a partner link for the file adapter, 5-22
  - configuring Adapter for Oracle Applications, 5-6
  - configuring the Assign activity, 5-33
  - configuring the Invoke activity, 5-26
  - creating a new SOA Composite application, 5-8
  - creating a partner link, 5-12
  - deploying the SOA Composite application, 5-36
  - design-time steps, 5-6
  - prerequisites to configure, 5-7
  - run-time steps, 5-36
  - testing the SOA Composite application, 5-41
  - verifying records, 5-43
- XML gateway outbound
  - design-time steps, 5-47
  - prerequisites to configure, 5-48
  - run-time steps, 5-69
  - testing the SOA Composite application, 5-74
- XML Gateway outbound
  - deploying the SOA Composite application, 5-70
- XML Gateway Outbound
  - adding a new partner link, 5-54
  - adding a new partner link for file adapter, 5-61
  - Adding a Receive Activity, 5-59
  - configuring the Assign activity, 5-67
  - configuring the Invoke activity, 5-65
  - creating a new SOA Composite application, 5-50